



235D

(Operator Manual)

MM331



This manual is furnished with each new TENNANT Model 235D. It provides necessary operating and preventive maintenance instructions. Read this manual completely and understand the machine before operating or servicing it.

This manual covers all machine variations and standard accessories. The tabbed instruction portion of the manual consists of the Specification, Operation, Maintenance, and Appendix sections. The tabbed parts section consists of the Standard Model Parts; Options; Hydraulic Components; Engine Parts, Diesel; and Cross Reference sections.

All right side and left side references to the machine are determined by facing the direction of forward travel. All hardware considered to be of a common nature or locally available has been omitted from the parts sections. Be aware that this machine may contain metric hardware. Make sure you use equivalent hardware when replacement becomes necessary.

This machine will provide excellent service. However, the best results will be obtained at minimum costs if:

- The machine is operated with reasonable care.
- The machine is maintained regularly - per the maintenance instructions provided.
- The machine is maintained with Tennant Company supplied or equivalent parts.

Parts and supplies may be ordered by phone or mail from any Tennant Company parts and service center, distributor, or from any of the Tennant Company subsidiaries. Before ordering parts or supplies, be sure to have your machine model number and serial number handy. Fill out the data block below for future reference. The telephone numbers, telex numbers, mailing addresses, and locations of those outlets are listed in the Customer Documents section of the manual.

MACHINE DATA <i>Please fill out at time of installation.</i>
Machine Serial Number - _____
Engine Serial Number - _____
Sales Representative - _____
Customer Number - _____
Date of Installation - _____
Manual Number - MM331
Revision: 03
Published: 8-95

Trademark Registered in: Austria, Benelux, Denmark, England, France, Germany, Italy, Spain, Switzerland, United States, Argentina, Australia, Canada, Japan, Mexico, Sweden, by TENNANT COMPANY, Minneapolis, Minnesota, U.S.A.

Acknowledgments: Technical information and/or illustrations supplied by Kubota Ltd.

Copyright 1993, 1994, 1995 Tennant Company, Printed in U.S.A.

ABOUT THIS MANUAL

The machine manual that you received with your TENNANT machine contains valuable information about the operation and maintenance, and numerous sections filled with TENNANT part numbers for the repair of the machine. Please read through this section titled *ABOUT THIS MANUAL* to become familiar with the contents of the machine manual, making the information you are looking for easier to find.

The machine manual consists of several sections of reference information, and the remainder contain part number information for ordering repair parts for the machine. Each section has a shaded bar at the top of the page with the name of that section. Just as this section has the title ABOUT THIS MANUAL on the top of each page. This way you can tell which section you are in at all times.

REFERENCE SECTIONS

The reference information sections of the manual are; General Information, Specifications, Operation, Maintenance, and Appendix.

GENERAL INFORMATION - The General Information section of the manual contains the safety precautions, the location of the safety labels on the machine, and a table of contents of the entire manual. The Safety Precautions are an overview of the safety measures to be observed when operating and maintaining your machine. The location of the safety labels show the mounting location of the safety labels for use in the replacement of the labels. The table of contents in this section is a list of all the table of contents that appear in the front of each section in the manual. This can be used for easy reference to locate information in a particular section of the manual.

SPECIFICATIONS - The Specifications section of the manual contains machine specification information useful in the operation and maintenance of the machine. This section gives you specification information on the engine, electric motors, brake system, hydraulics, fluid capacities, and machine weight to mention a few. The section also has a illustration of the top and side view of the machine with the height and width dimensions displayed.

OPERATION - The Operation section of the manual contains information needed to operate the machine. This section will list the controls and instruments on the machine, overview the machine operation, and tell you how to transport and store the machine.

MAINTENANCE - The Maintenance section contains information on the suggested maintenance procedures and adjustments to keep your machine in top operating condition. The section includes a Maintenance Chart listing the maintenance schedule and the areas of the machine to be addressed. Each subject of maintenance is covered in more detail in such areas as Lubrication, Hydraulics, Engine, and Electrical System.

APPENDIX - The Appendix contains hardware and hydraulic information. Standard hardware torques and identification information is included, plus hydraulic torques if your machine is hydraulically controlled.

PART SECTIONS

The remaining sections of the manual contain part number information for ordering repair parts for your machine. The manual contains part number information on every type of machine model available in the model size of your particular machine. Therefore there will be part number information in your manual you will not need to refer to when wanting to place an order.

The main thing you need to know about your machine is what type of model is it. Is the machine powered by an engine or batteries? If the machine has an engine, is it fueled from gasoline, LPG, or diesel? If it is a mid-sized or larger sweeper, is it multi-level or low dump? For the scrubbers, is it SRS® or standard. Determining this information about your machine will help guide you through the separate parts sections to find the repair part you need.

ABOUT THIS MANUAL

The smaller line of sweeper and scrubbers have less complicated part section arrangement, and are easier to find your way through the parts sections. The larger machines can have quite a variety of model types which significantly increases the size to the machine manual. Because of this, on the larger machine we made the first part section, Section 5, a part section which contains parts common to all type of the machine. If the machine has an engine, this section contains parts information on a gasoline powered machine.

The remaining sections contain only parts information which is unique to that particular machine type, such as unique diesel parts on the machine, or unique SRS® parts. Knowing the machine model type you have is important when searching for that part information you need for ordering repair parts. Start in that unique section first when looking for a part, then go to the first parts section, Section 5, if the part can't be found in the unique section.

MACHINE SERIAL NUMBERS

When a design change takes place to a machine, the changes are indicated in the parts sections with machine serial numbers. Know the serial number of your machine which can be found on the machine data plate mounted on the machine. Record this number on the inside front cover of your manual along with your customer number.

Machine number usage is recorded in the *Machine Serial Number* column of the parts lists in the parts sections of the manual. If the machine serial number column lists zeros on the left side of the dash, then this part is used on all machines; such as (000000-).

If the column lists zeros on the left of the dash and a number on the right of the dash, then the part is used on machines up to and including that machine serial number; such as (00000-002345).

For parts that are used on machines beginning at and continuing on from a certain serial number, the column would list a serial number on the left of the dash and have blank spaces on the right side of the dash; such as (002346-). This part would be used on machines starting with that machine serial number and greater.

Finally, parts can be used on machines with serial numbers in a certain block of numbers. In this situation there is a serial number on the left and right side of the dash. The part is then used on a machine with a serial number starting at the number on the left and up to and including the number on the right; such as (002346-008900).

PARTS ASSEMBLIES

A part assembly has parts within the assembly, such as a parking brake consisting of other smaller parts. What parts are contained in a part assembly can be determined by an indentation arrangement in the description column of the parts lists.

Here is an example of a part assembly, in this case we will use the parking brake mentioned previously:

Machine			
Serial Number	Description	Qty.	
(000000-)	Parking Brake	1	
(000000-)	Pin, Roll	1	
(000000-)	Link	1	
(000000-)	Spring, Compression	1	
(000000-)	Pin, Roll	1	
(000000-)	Support	1	
(000000-)	Lever, Release	1	
(000000-)	Rod, Parking Brake	1	
(000000-)	Washer, 0.50"	3	

In this example, the parts whose descriptions are indented under the parking brake are all parts of the parking brake. When you order the parking brake you will receive all the parts listed under it. You also can order any of the individual parts listed under the parking brake if it is the only part you need.

SUPPLIER COMPONENT BREAKDOWNS

TENNANT purchases certain components of the machine from suppliers. Some of these components are engines, hydraulic pumps and motors, electric motors, and solution pumps.

For those purchased components that are repairable, lists of parts for them appear in the later part of the parts sections. These are the supplier breakdowns. The engine breakdown contains both supplier and TENNANT parts numbers for repair parts. Breakdowns for hydraulic and electrical components have TENNANT part numbers for the parts TENNANT supplies. The serial numbers listed in any of the parts lists in these sections is a serial number the manufacturer uses to identify design changes in their particular component.

ORDERING REPAIR PARTS

Once you have located a part to order, there are several things you need to have to place the order. At the beginning of each parts section is an Ordering Repair Parts page which lists the information you will need to place your order. Review this list before placing the order.

SAFETY PRECAUTIONS

The following symbols are used throughout this manual as indicated in their descriptions:

 **WARNING:** To warn of hazards or unsafe practices which could result in severe personal injury or death.

FOR SAFETY: To identify actions which must be followed for safe operation of equipment.

The following information signals potentially dangerous conditions to the operator or equipment. Read this manual carefully. Know when these conditions can exist. Locate all safety devices on the machine. Then, take necessary steps to train machine operating personnel. Report machine damage or faulty operation immediately. Do not use the machine if it is not in proper operating condition.

FOR SAFETY:

1. **Do Not Operate Machine:**
 - Unless Trained And Authorized.
 - Unless Operation Manual Is Read And Understood.
 - In Flammable Or Explosive Areas Unless Designed For Use In Those Areas.
 - In Areas With Possible Falling Objects Unless Equipped With Overhead Guard.
2. **Before Starting Machine:**
 - Check For Fuel Leaks.
 - Keep Sparks And Open Flame Away From Refueling Area.
 - Make Sure All Safety Devices Are In Place And Operate Properly.
 - Check Brakes And Steering For Proper Operation.
3. **When Starting Machine:**
 - Keep Foot On Brake And Directional Pedal In Neutral.
4. **When Using Machine:**
 - Use Brakes To Stop Machine.
 - Go Slow On Grades And Slippery Surfaces.
 - Use Care When Backing Machine.
 - Move Machine With Care When Hopper Is Raised.
 - Make Sure Adequate Clearance Is Available Before Raising Hopper.
 - Do Not Carry Riders On Machine.
 - Always Follow Safety And Traffic Rules.

5. **Before Leaving Or Servicing Machine:**
 - Stop On Level Surface.
 - Set Parking Brake.
 - Turn Off Machine And Remove Key.
6. **When Servicing Machine:**
 - Avoid Moving Parts. Do Not Wear Loose Jackets, Shirts, Or Sleeves When Working On Machine.
 - Block Machine Tires Before Jacking Machine Up.
 - Jack Machine Up At Designated Locations Only. Block Machine Up With Jack Stands.
 - Use Hoist Or Jack Of Adequate Capacity To Lift Machine.
 - Wear Eye And Ear Protection When Using Pressurized Air Or Water.
 - Disconnect Battery Connections Before Working On Machine.
 - Avoid Contact With Battery Acid.
 - Avoid Contact With Hot Engine Coolant.
 - Allow Engine To Cool.
 - Keep Flames And Sparks Away From Fuel System Service Area. Keep Area Well Ventilated.
 - Use Cardboard To Locate Leaking Hydraulic Fluid Under Pressure.
 - Use TENNANT Supplied Or Equivalent Replacement Parts.

 **WARNING:** Engine Emits Toxic Gases. Severe Respiratory Damage Or Asphyxiation Can Result. Provide Adequate Ventilation. Consult With Your Regulatory Agency For Exposure Limits. Keep Engine Properly Tuned.

 **WARNING:** Machine Can Emit Excessive Noise. Consult With Your Regulatory Agency For Exposure Limits. Hearing Loss Can Result. Wear Hearing Protection.

 **WARNING:** Lift Arm Pinch Point. Stay Clear Of Hopper Lift Arms.

 **WARNING:** Raised Hopper May Fall. Engage Hopper Support Bar.

 **WARNING:** Moving Belt. Keep Away.

GENERAL INFORMATION

The following safety labels are mounted on the machine in the locations indicated. If these, or any, labels become damaged or illegible, install a new label in its place.

FOR SAFETY LABEL - LOCATED ON THE SIDE OF THE CONTROL PANEL.

FOR SAFETY

1. Do Not Operate Machine:
 - Unless Trained And Authorized.
 - Unless Operation Manual Is Read And Understood.
 - In Flammable Or Explosive Areas.
 - In Poorly Ventilated Areas.
2. Do Not Raise Hopper Without First Turning Off Main And Side Brushes.
3. Do Not Use Flammable Cleaning Agents.
4. Check For Fuel Leaks.
5. Go Slow On Grades And Slippery Surfaces.
6. Before Leaving Machine:
 - Stop On Level Surface
 - Stop Engine And Set Parking Brake
 - When Parking, Remove Key
7. Use Tennant Company Supplied Or Equivalent Replacement Parts.

03402

FOR SAFETY THERMO SENTRY™ LABEL - LOCATED ON THE LIFT ARM CROSS MEMBER.

FOR SAFETY

Check Fire Sensing Circuit Every 100 Hours.

1. Apply Heat To Sensor With Match Or Similar Device.
2. After Sensor Has Cooled Reset Circuit Breaker Located Behind Control Panel.
3. See Manual For Further Instructions.

03403

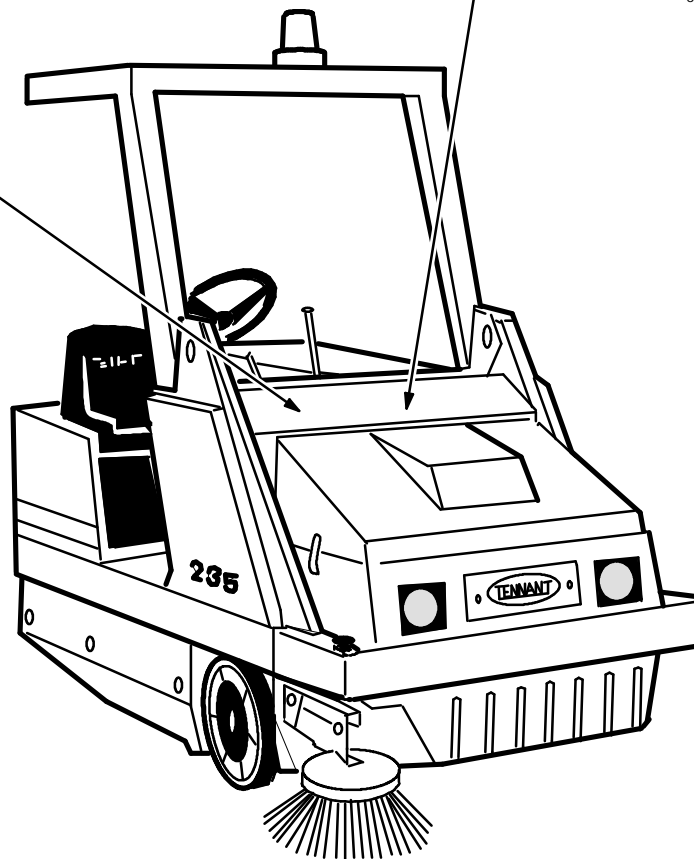

03486

HOPPER SUPPORT BAR WARNING LABEL -
LOCATED ON THE OPERATOR SIDE OF
HOPPER LIFT ARM.

	<p>WARNING Engage Safety Support Bar Per Instructions Before Working Under Hopper</p>	<p>INSTRUCTIONS</p> <p>SAFETY SUPPORT BAR</p>	<p>To Engage Safety Support Bar:</p> <ol style="list-style-type: none"> 1. Lift Hopper To Extreme Up Position. 2. Set Parking Brake. 3. Dismount Machine And Lower Safety Support Bar Over Bar Stand. 4. Lower Hopper Onto Support Bar. 5. Shut Off Engine.
--	--	--	--

03398

	<p>WARNING Keep Away From Fan Belt Drive.</p>
--	--

03397

FAN BELT DRIVE WARNING LABEL -
LOCATED ON THE VACUUM FAN.

	<p>CAUTION Stay Clear Of Hopper Lift Arms.</p>
--	---

03401

HOPPER LIFT ARM PINCH POINT CAUTION LABEL (2) - LOCATED ON THE HOPPER LIFT ARMS.

	<p>WARNING Engage Safety Support Bar Per Instructions Before Working Under Hopper</p>
--	--

03399

FALLING HOPPER WARNING LABEL -
LOCATED ON THE FRONT OF THE BRUSH WRAP.

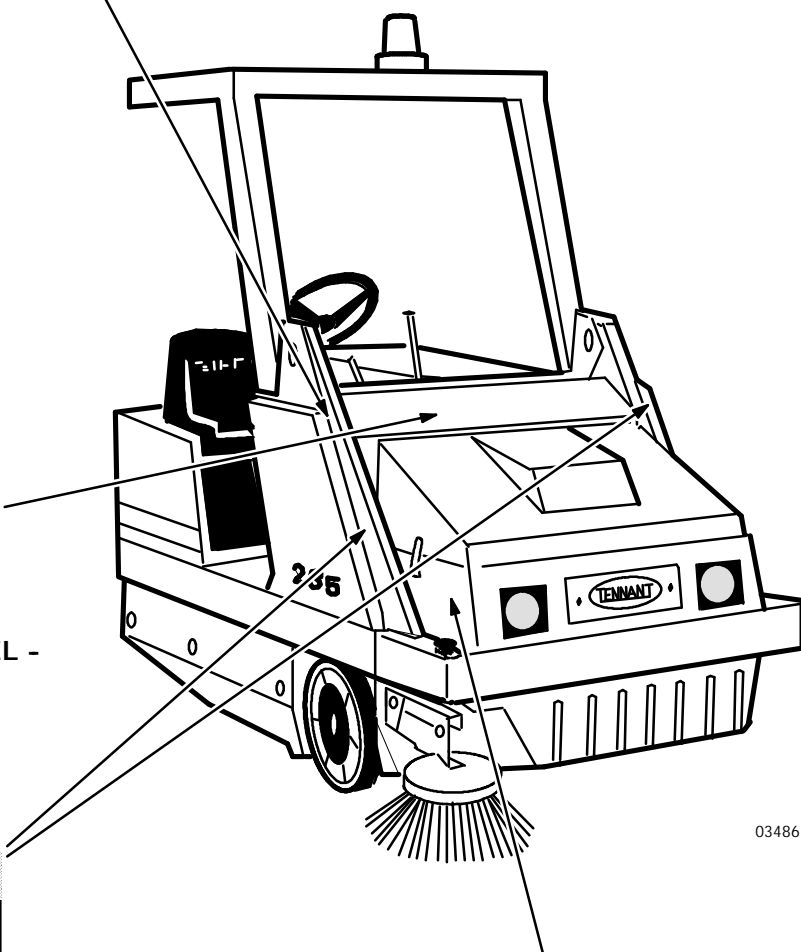

03486

CONTENTS

	Page		Page
GENERAL INFORMATION	i	MACHINE OPERATION	2-10
SAFETY PRECAUTIONS	i	NORMAL SWEEPING OPERATION	2-10
SPECIFICATIONS	1-1	PRE-START CHECKLIST	2-10
MACHINE SPECIFICATIONS	1-3	TO START MACHINE	2-10
POWER TYPE	1-3	TO SWEEP	2-11
POWER TRAIN	1-3	TO DUMP HOPPER	2-11
STEERING	1-3	POST OPERATION CHECKLIST -	
HYDRAULIC SYSTEM	1-3	ENGINE OPERATING	2-11
BRAKING SYSTEM	1-3	TO STOP MACHINE	2-12
SUSPENSION SYSTEM	1-3	POST OPERATION CHECKLIST -	
SYSTEM FLUID CAPACITIES	1-4	ENGINE STOPPED	2-12
GENERAL MACHINE DIMENSIONS -		TO ENGAGE HOPPER	
CAPACITIES	1-4	SUPPORT BAR	2-12
MACHINE WEIGHTS	1-4	TO DISENGAGE HOPPER	
MACHINE DIMENSIONS	1-5	SUPPORT BAR	2-13
OPERATION	2-1	OPERATION ON GRADES	2-13
PREPARATION FOR OPERATION	2-3	MACHINE TROUBLESHOOTING ..	2-14
AFTER UNCRATING AND BEFORE		TRANSPORTING MACHINE	2-15
OPERATING MACHINE:	2-3	PUSHING OR TOWING MACHINE .	2-15
OPERATION OF CONTROLS	2-4	MACHINE JACKING	2-15
MACHINE COMPONENTS	2-4	TO JACK UP MACHINE	2-15
CONTROLS AND INSTRUMENTS .	2-5	MACHINE TIE-DOWNS	2-16
BRAKE PEDAL	2-6	MACHINE STORAGE	2-17
DIRECTIONAL PEDAL	2-6	STORING MACHINE	2-17
PARKING BRAKE LEVER	2-6	MAINTENANCE	3-1
OPERATOR SEAT	2-6	RECOMMENDED FIRST 50-HOUR	
ADJUSTABLE SEAT LEVER (OPTION)	2-6	MACHINE INSPECTION	3-3
SEAT SUPPORT LEVER	2-6	MAINTENANCE CHART	3-4
SIDE BRUSH AND HOPPER LEVER	2-6	LUBRICATION	3-6
THROTTLE LEVER	2-6	ENGINE	3-6
TEMP LIGHT	2-6	SIDE BRUSH LEVER PIVOT	3-6
AMPS LIGHT	2-6	REAR WHEEL SUPPORT BEARING	3-7
OIL PRESSURE LIGHT	2-7	STEERING LINKAGE	3-7
HOPPER DOOR SWITCH	2-7	HYDRAULICS	3-8
LIGHT SWITCH	2-7	HYDRAULIC FLUID	3-8
KEY-OPERATED IGNITION SWITCH	2-7	HYDRAULIC FLUID RESERVOIR ..	3-8
MAIN BRUSH LEVER	2-7	HYDRAULIC FILTER	3-8
GLOW PLUG INDICATOR	2-7	TO REPLACE FILTER ELEMENT	3-9
VACUUM LEVER	2-7	HYDRAULIC PUMPS	3-9
HOUR METER	2-7	TO START AND BREAK-IN	
FUEL LEVEL GAUGE	2-7	HYDRAULIC PUMP	3-9
FLASHER SWITCH	2-7	DIRECTIONAL PEDAL	3-10
STEERING WHEEL	2-7	TO ADJUST DIRECTIONAL	
HORN BUTTON	2-7	PEDAL LINKAGE	3-10
SIDE BRUSH LEVER	2-8	LIFT ARM SPEED LIMITER	3-11
SIDE BRUSH ADJUSTMENT KNOB	2-8	HYDRAULIC FLUID LEAKS	3-12
AUXILIARY SIDE BRUSH		HYDRAULIC SCHEMATIC	3-13
IN-OUT SWITCH (OPTION)	2-8	HYDRAULIC SYSTEM	
AUXILIARY SIDE BRUSH		TROUBLESHOOTING	3-14
UP-DOWN SWITCH (OPTION) ..	2-8	HYDRAULIC COMPONENTS	
CIRCUIT BREAKERS	2-9	TROUBLESHOOTING	3-15
HOPPER SUPPORT BAR	2-9		

	Page		Page
ENGINE	3-16	BRUSHES	3-34
ENGINE LUBRICATION	3-16	MAIN BRUSH	3-34
COOLING SYSTEM	3-16	TO REMOVE MAIN BRUSH	3-34
AIR INTAKE SYSTEM	3-17	TO INSTALL MAIN BRUSH	3-34
AIR FILTER	3-18	TO CHECK AND ADJUST MAIN	
TO REPLACE AIR		BRUSH PATTERN	3-34
FILTER ELEMENT	3-18	SIDE BRUSH	3-36
FUEL SYSTEM	3-19	TO REMOVE SIDE BRUSH	3-36
FUEL SYSTEM	3-19	TO INSTALL SIDE BRUSH	3-36
FUEL WATER TRAP FILTER	3-19	SKIRTS AND SEALS	3-37
TO REPLACE FUEL		BRUSH SKIRTS	3-37
FILTER ELEMENT	3-19	TO REPLACE AND ADJUST	
PRIMING FUEL SYSTEM	3-20	BRUSH SKIRTS	3-37
TO PRIME FUEL SYSTEM	3-20	REAR SKIRTS	3-37
DIESEL FUEL TROUBLESHOOTING	3-21	TO REPLACE AND ADJUST	
CYLINDER HEAD	3-22	REAR SKIRTS	3-37
CYLINDER HEAD	3-22	HOPPER LIP SKIRT	3-38
VALVE CLEARANCE	3-22	TO REPLACE HOPPER	
DECOMPRESSION LEVER	3-22	LIP SKIRT	3-38
ELECTRICAL SYSTEM	3-23	DUST SEALS	3-38
BATTERY	3-23	TO REPLACE DUST SEALS	3-38
ELECTRICAL SCHEMATIC	3-24	HOPPER DUMP DOOR SEAL	3-39
ELECTRICAL SCHEMATIC,		TO REPLACE HOPPER DUMP	
AUXILIARY SIDE BRUSH	3-25	DOOR SEAL	3-39
BELTS AND CHAINS	3-26	VACUUM FAN SEAL	3-40
HYDRAULIC PUMP BELT	3-26	FILTER COVER SEAL	3-40
TO REPLACE AND ADJUST		BRAKES AND TIRES	3-41
HYDRAULIC PUMP BELT	3-26	BRAKES	3-41
VACUUM FAN BELT	3-26	TIRES	3-41
TO REPLACE AND ADJUST		REAR WHEEL	3-41
VACUUM FAN BELT	3-26	APPENDIX	4-1
MAIN BRUSH BELT	3-28	HARDWARE INFORMATION	4-3
TO REPLACE MAIN		STANDARD BOLT TORQUE CHART	4-3
BRUSH BELT	3-28	METRIC BOLT TORQUE CHART ..	4-3
FAN BELT	3-28	BOLT IDENTIFICATION	4-3
TO REPLACE AND ADJUST		THREAD SEALANT AND LOCKING	
FAN BELT	3-28	COMPOUNDS	4-3
TAPER LOCK BUSHINGS	3-30	HYDRAULIC FITTING INFORMATION .	4-4
TO REMOVE TAPER		HYDRAULIC TAPERED PIPE FITTING	
LOCK BUSHING	3-30	(NPT) TORQUE CHART	4-4
TO INSTALL TAPER		HYDRAULIC TAPERED SEAT FITTING	
LOCK BUSHING	3-30	(JIC) TORQUE CHART	4-4
STATIC DRAG CHAIN	3-30	HYDRAULIC O-RING FITTING TORQUE	
DEBRIS HOPPER AND DUST FILTER .	3-31	CHART	4-4
DEBRIS HOPPER	3-31		
TO CHECK AND ADJUST HOPPER			
FLOOR CLEARANCE	3-31		
THERMO SENTRY™	3-31		
TO CHECK THE			
THERMO SENTRY™	3-31		
HOPPER DUST FILTER	3-32		
TO REMOVE AND REPLACE			
HOPPER DUST FILTER	3-33		

GENERAL INFORMATION

	Page		Page
STANDARD MODEL PARTS	5-1	HYDRAULIC COMPONENTS	7-1
ORDERING REPAIR PARTS	5-3	ORDERING REPAIR PARTS	7-3
Fig. 1 - Recommended General Maintenance Items	5-4	Fig. 1 - Hydraulic Motor Breakdown, 87417	7-4
Fig. 2 - Replacement Brushes	5-5	Fig. 2 - Hydraulic Motor Breakdown, 87475	7-5
Fig. 3 - Main Frame Group	5-6	Fig. 3 - Hydraulic Valve Breakdown, 87409	7-6
Fig. 4 - Seat and Shrouds Group	5-8	Fig. 4 - Hydraulic Pump Breakdown, 87734	7-7
Fig. 5 - Front Wheel and Brake Group	5-10	Fig. 5 - Hydraulic Lift Cylinder Breakdown, 87055	7-8
Fig. 6 - Hopper Lift Arms Group	5-12	Fig. 6 - Hydraulic Lift Cylinder Breakdown, 48575	7-9
Fig. 7 - Hopper Middle and Cover Group	5-14	Fig. 7 - Hydraulic Lift Cylinder Breakdown, 65223	7-10
Fig. 8 - Hopper Bottom Group	5-16	Fig. 8 - Hydraulic Pump Breakdown, 87451	7-11
Fig. 9 - Hopper Headlights and Access Door Group	5-18	Fig. 9 - Hydraulic Motor Breakdown, 28804	7-12
Fig. 10 - Hopper Filter and Shaker Motor Group	5-19	ENGINE PARTS, DIESEL	8-1
Fig. 11 - Hopper Dump Door and Actuator Group	5-20	ORDERING REPAIR PARTS	8-3
Fig. 12 - Vacuum Fan Control Group	5-22	Fig. 1 - Crankcase Group	8-4
Fig. 13 - Vacuum Fan Assembly	5-24	Fig. 2 - Gear Case Group	8-6
Fig. 14 - Main Brush Drive Group	5-26	Fig. 3 - Cylinder Head Group	8-8
Fig. 15 - Main Brush Idler Group	5-28	Fig. 4 - Bearing Case Group	8-9
Fig. 16 - Side Brush Group	5-30	Fig. 5 - Breather Group	8-10
Fig. 17 - Hydraulic Lift Cylinder and Filter Group	5-32	Fig. 6 - Air Cleaner and Manifolds Group	8-12
Fig. 18 - Pump Group	5-34	Fig. 7 - Valve, Rocker Arm Group	8-14
Fig. 19 - Control Valve and Throttle Group	5-36	Fig. 8 - Head Cover Group	8-15
Fig. 20 - Hydraulic Reservoir Group	5-38	Fig. 9 - Camshaft Group	8-16
Fig. 21 - Rear Drive Wheel Group	5-39	Fig. 10 - Piston, Crankshaft Group	8-18
Fig. 22 - Hydraulic Hoses Group	5-40	Fig. 11 - Flywheel Group	8-20
Fig. 23 - Steering Wheel Group	5-42	Fig. 12 - Injection Pump Group	8-21
Fig. 24 - Directional Pedal Group	5-44	Fig. 13 - Governor Group	8-22
Fig. 25 - Speed Limiter Group	5-45	Fig. 14 - Radiator Group	8-24
Fig. 26 - Engine Group	5-46	CROSS REFERENCE	9-1
Fig. 27 - Fuel Tank and Fuel Line Group	5-48	PART NUMBER TO PAGE NUMBER CROSS REFERENCE LIST	9-3
Fig. 28 - Control Panel Group	5-50		
Fig. 29 - Wire Harness Group	5-52		
Fig. 30 - Labels Group	5-54		
OPTIONS	6-1		
ORDERING REPAIR PARTS	6-3		
Fig. 1 - Cab Kit	6-4		
Fig. 2 - Overhead Guard Kit	6-5		
Fig. 3 - Revolving Light Kit, Overhead Guard	6-6		
Fig. 4 - Revolving Light Kit, Shroud	6-7		
Fig. 5 - Demo Kit	6-8		
Fig. 6 - Foam Filled Tire Kit	6-8		
Fig. 7 - Adjustable Seat Kit	6-9		
Fig. 8 - Oil Drain Kit	6-10		
Fig. 9 - Auxiliary Side Brush Electrical Group	6-11		
Fig. 10 - Auxiliary Side Brush Group	6-12		
Fig. 11 - Auxiliary Side Brush Hydraulic Hose Group	6-14		

SECTION 1**CONTENTS**

	Page
MACHINE SPECIFICATIONS	1-3
POWER TYPE	1-3
POWER TRAIN	1-3
STEERING	1-3
HYDRAULIC SYSTEM	1-3
BRAKING SYSTEM	1-3
SUSPENSION SYSTEM	1-3
SYSTEM FLUID CAPACITIES	1-4
GENERAL MACHINE DIMENSIONS - CAPACITIES	1-4
MACHINE WEIGHTS	1-4
MACHINE DIMENSIONS	1-5

MACHINE SPECIFICATIONS**POWER TYPE**

Engine type - piston
Ignition - diesel
Cycle - 4
Aspiration - natural
Cylinders - 2
Bore - 2.83 in (72 mm)
Stroke - 2.76 in (70 mm)
Displacement - 35 cu in (575 cc)
Net power - 11 hp (8.2 kw) @ 2200 rpm governed
Net power - 14 hp (10.4 kw) @ 3200 rpm maximum
Fuels - No. 2 diesel fuel
Cooling system - water/ethylene glycol antifreeze
Electrical system - 12 V nominal, 37 A alternator

POWER TRAIN

Propelling - hydraulic motor driven
Main brush - belt driven
Side brush - hydraulic motor driven
Vacuum fan - belt driven
Hydraulic pump - belt driven

STEERING

Type - rear wheel controlled, automotive cam and lever
Power source - manual

HYDRAULIC SYSTEM

Function - operates propelling, hopper lift, side brush drive
Control valve, hopper lift, side brush drive - open center, single spool type
Pump, propelling - variable displacement piston type, 0.85 cu in (14 cc) maximum displacement per revolution, 9.1 gpm (35 L/min) @ 2400
Propelling system relief pressure - 2000 psi (13,790 kPa)
Pump, accessories - gear type, 0.26 cu in (4 cc) displacement, 1.1 gpm (4 L/min) @ 1000 rpm
Side brush and lift cylinder system relief pressure - 1350 psi (9310 kPa)
Motor, side brush - internal gear type, 2.8 cu in (46 cc) per revolution, 2500 psi (17,240 kPa) maximum rated pressure
Cylinder, hopper lift - single action type, 2.5 in (65 mm) bore x 12 in (305 mm) stroke, 1.125 in (30 mm) diameter rod, 3000 psi (20,685 kPa) maximum rated pressure.
Filter - spin-on type, 10 micron nominal, 25 psi (170 kPa) bypass pressure

BRAKING SYSTEM

Service brakes - mechanical drum brakes (2) - 1 per front wheel, linkage actuated
Parking brakes - utilizes service brakes, linkage actuated

SUSPENSION SYSTEM

Front - 15 x 3.00 solid tires (2)
Rear - 4.80 x 8 pneumatic tire (1)

SPECIFICATIONS

SYSTEM FLUID CAPACITIES

Hydraulic system - reservoir 3.9 gal (14.8 L)

Hydraulic system - total 4.4 gal (16.7 L)

Engine lubricating oil, with filter - 3.2 qt (3 L)

Engine cooling system - 3.2 qt (3 L)

Fuel tank - 7.3 gal (28L)

GENERAL MACHINE DIMENSIONS - CAPACITIES

Length - 77.5 in (1970 mm)

Width with side brush - 48 in (1220 mm)

Height without overhead guard - 53 in (1345 mm)

Height with overhead guard - 79.5 in (2020 mm)

Track - front 44 in (1115 mm)

Wheel base - 41 in (1040 mm)

Main brush - width 36 in (915 mm)

Main brush outside diameter - 14 in (355 mm)

Side brush rotary diameter - 19 in (480 mm)

Sweeping path width (total) - 48 in (1220 mm)

Hopper capacity - 10 cu ft (0.28 m³) 650 lb
(295 kg)

Dust filter - 49 sq ft (4.5 m²), pleated panel filter
element

MACHINE WEIGHTS

Net weight, dry - 1840 lb (835 kg)

GVWR - 2780 lb (1260 kg)

GENERAL MACHINE PERFORMANCE

Maximum forward speed - 6 mph (10 km/h)

Maximum reverse speed - 3 mph (5 km/h)

Maximum forward speed with raised hopper -
2 mph (3.2 km/h)

Turning radius - left, 60 in (1525 mm) right, 78 in
(1980 mm)

Maximum rated climb and descent angle - 10°

MACHINE DIMENSIONS

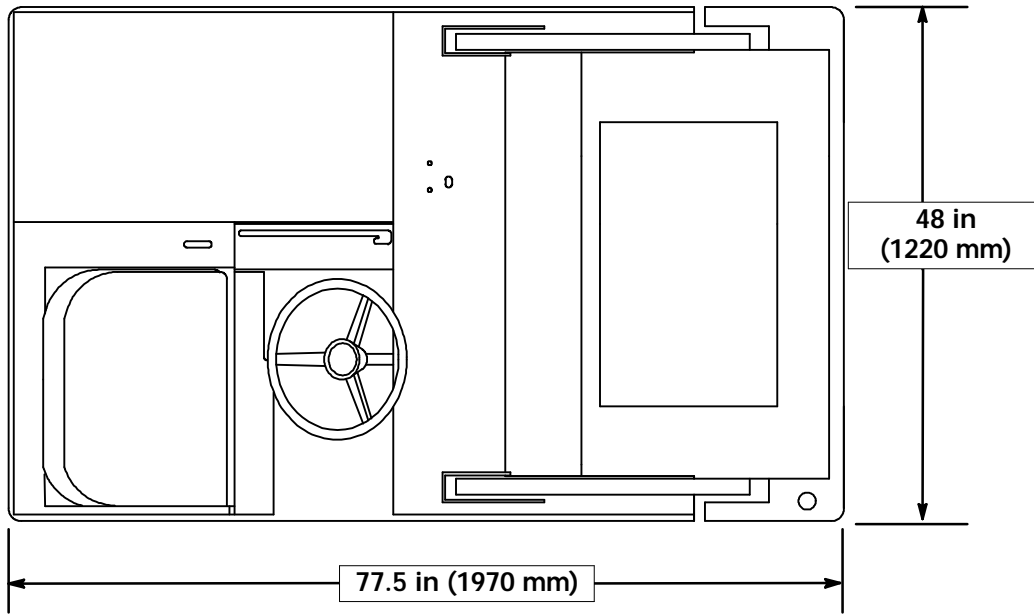

TOP VIEW

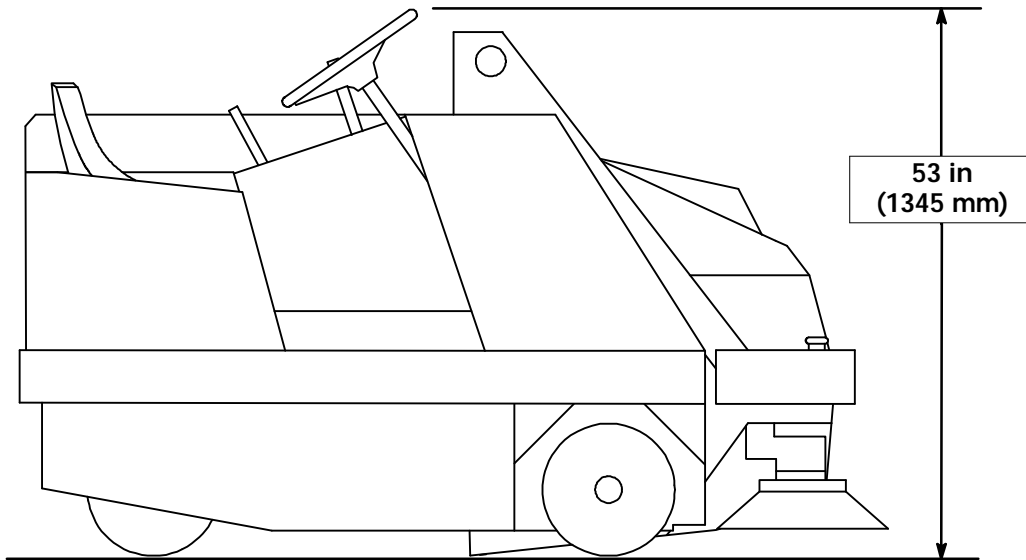

SIDE VIEW

03366

SECTION 2

CONTENTS

	Page		Page
PREPARATION FOR OPERATION	2-3	MACHINE OPERATION	2-10
AFTER UNCRATING AND BEFORE		NORMAL SWEEPING OPERATION ...	2-10
OPERATING MACHINE:	2-3	PRE-START CHECKLIST	2-10
OPERATION OF CONTROLS	2-4	TO START MACHINE	2-10
MACHINE COMPONENTS	2-4	TO SWEEP	2-11
CONTROLS AND INSTRUMENTS	2-5	TO DUMP HOPPER	2-11
BRAKE PEDAL	2-6	POST OPERATION CHECKLIST -	
DIRECTIONAL PEDAL	2-6	ENGINE OPERATING	2-11
PARKING BRAKE LEVER	2-6	TO STOP MACHINE	2-12
OPERATOR SEAT	2-6	POST OPERATION CHECKLIST -	
ADJUSTABLE SEAT LEVER (OPTION)	2-6	ENGINE STOPPED	2-12
SEAT SUPPORT LEVER	2-6	TO ENGAGE HOPPER SUPPORT BAR	2-12
SIDE BRUSH AND HOPPER LEVER ...	2-6	TO DISENGAGE HOPPER	
THROTTLE LEVER	2-6	SUPPORT BAR	2-13
TEMP LIGHT	2-6	OPERATION ON GRADES	2-13
AMPS LIGHT	2-6	MACHINE TROUBLESHOOTING	2-14
OIL PRESSURE LIGHT	2-7	TRANSPORTING MACHINE	2-15
HOPPER DOOR SWITCH	2-7	PUSHING OR TOWING MACHINE	2-15
LIGHT SWITCH	2-7	MACHINE JACKING	2-15
KEY-OPERATED IGNITION SWITCH ..	2-7	TO JACK UP MACHINE	2-15
MAIN BRUSH LEVER	2-7	MACHINE TIE-DOWNS	2-16
GLOW PLUG INDICATOR	2-7	MACHINE STORAGE	2-17
VACUUM LEVER	2-7	STORING MACHINE	2-17
HOUR METER	2-7		
FUEL LEVEL GAUGE	2-7		
FLASHER SWITCH	2-7		
STEERING WHEEL	2-7		
HORN BUTTON	2-7		
SIDE BRUSH LEVER	2-8		
SIDE BRUSH ADJUSTMENT KNOB ...	2-8		
AUXILIARY SIDE BRUSH			
IN-OUT SWITCH	2-8		
AUXILIARY SIDE BRUSH			
UP-DOWN SWITCH	2-8		
CIRCUIT BREAKERS	2-9		
HOPPER SUPPORT BAR	2-9		

PREPARATION FOR OPERATION**AFTER UNCRATING AND BEFORE OPERATING MACHINE:**

1. Check the machine for shipping damage.
2. Read this manual carefully before operating or servicing the machine.

FOR SAFETY: Do Not Operate Machine, Unless Operation Manual Is Read And Understood.

3. Check the hydraulic fluid level in the hydraulic fluid reservoir. See *HYDRAULICS* in the *MAINTENANCE* section.
4. Check the main brush adjustment. See *BRUSHES* in the *MAINTENANCE* section.

5. Check the engine oil level. See *ENGINE* in the *MAINTENANCE* section.
6. Fill the fuel tank on the machine.

FOR SAFETY: When Servicing Machine, Keep Flames And Sparks Away From Fuel System Service Area. Keep Area Well Ventilated.

7. Check the radiator coolant level in the coolant tank.

OPERATION OF CONTROLS

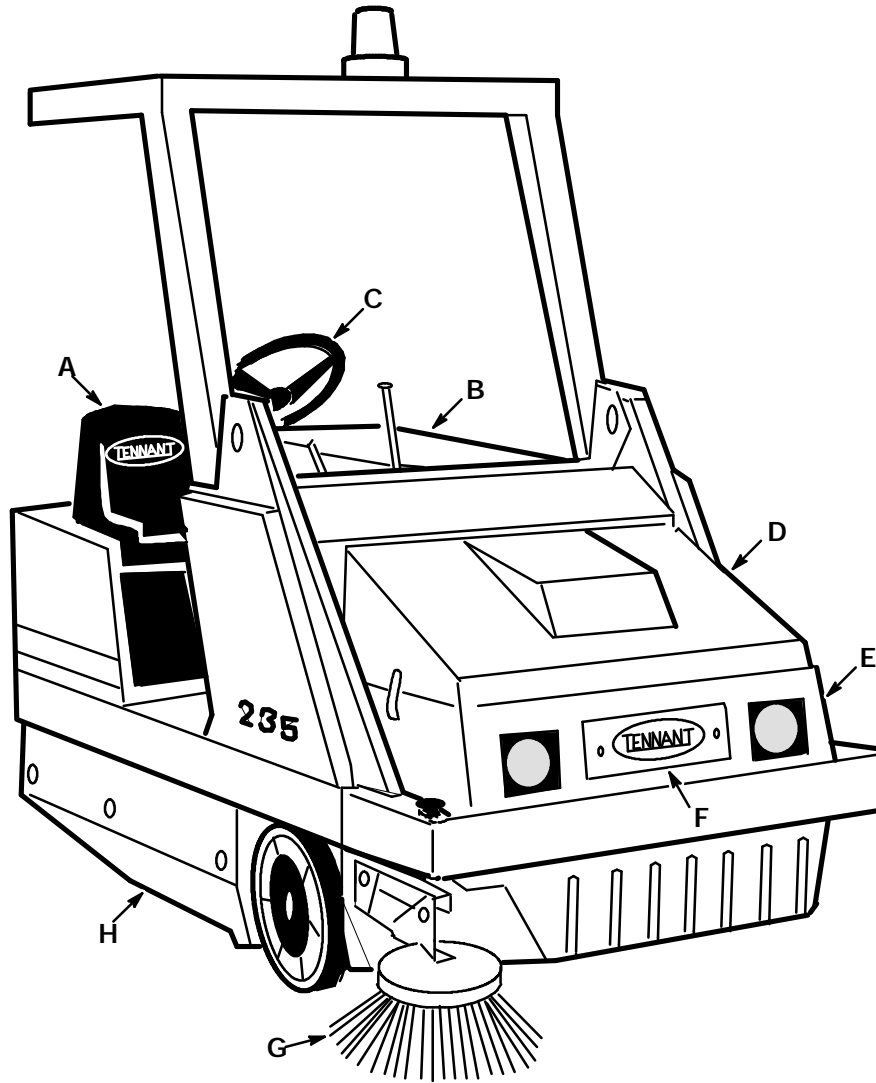

MACHINE COMPONENTS

03486

- | | |
|-------------------|---------------------------|
| A. Operator Seat | E. Hopper |
| B. Seat Support | F. Hopper Inspection Door |
| C. Steering Wheel | G. Side Brush |
| D. Filter Cover | H. Access Door |

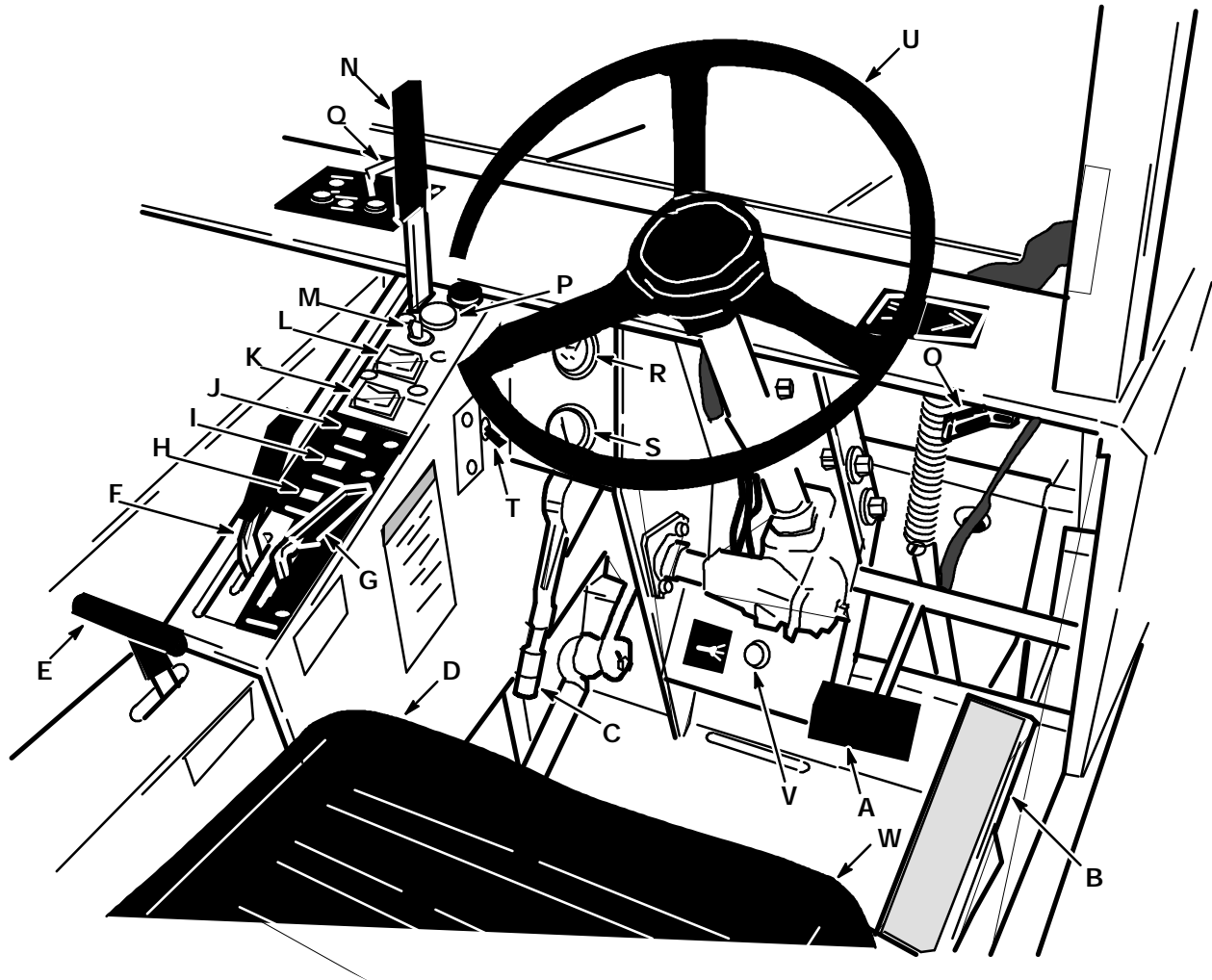

CONTROLS AND INSTRUMENTS

03487

- | | |
|--------------------------------|----------------------------------|
| A. Brake Pedal | M. Key-Operated Ignition Switch |
| B. Directional Pedal | N. Main Brush Lever |
| C. Parking Brake Lever | O. Side Brush Lever |
| D. Operator Seat | P. Glow Plug Indicator |
| E. Seat Support Lever | Q. Vacuum Lever |
| F. Side Brush and Hopper Lever | R. Hour Meter |
| G. Throttle Lever | S. Fuel Level Gauge |
| H. Temp Light | T. Flasher Switch |
| I. Amps Light | U. Steering Wheel |
| J. Oil Pressure Light | V. Horn Button |
| K. Hopper Door Switch | W. Auxiliary Side Brush Switches |
| L. Lights Switch | |

BRAKE PEDAL

The brake pedal operates the brakes on the two front wheels. To stop the machine, return the direction pedal to neutral, then apply pressure to the brake pedal.

DIRECTIONAL PEDAL

The directional pedal controls the propelling drive. It is used to select the direction of travel and the speed of the machine.

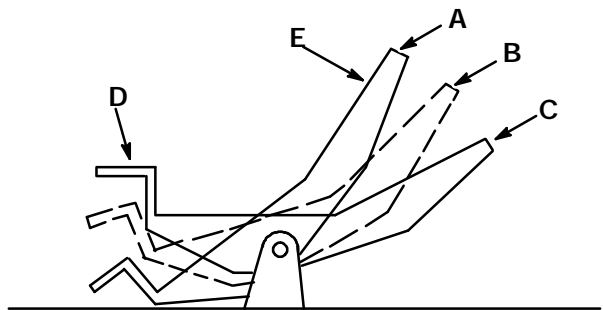

DIRECTIONAL PEDAL POSITIONS

00116

- A. "Reverse" Position
- B. "Neutral" Position
- C. "Forward" Position
- D. "Heel" Position
- E. "Toe" Position

Gradually press the "toe" portion of the pedal for forward travel or the "heel" portion for reverse travel. Regulate the machine speed by varying the pressure on the directional pedal.

PARKING BRAKE LEVER

The parking brake lever operates the front wheel brakes. To set the parking brake, pull the handle up. To release the parking brake, push the handle down. Always park on a level surface, stop the engine, and set the parking brake before leaving the machine unattended and before working on the machine.

FOR SAFETY: Before Leaving Or Servicing Machine; Stop On Level Surface, Set Parking Brake, Turn Off Machine And Remove Key.

OPERATOR SEAT

The operator seat is of the fixed-back style with a forward-backward adjustment. To adjust the seat, remove the seat mounting bolts, slide the seat to the position desired, and reinstall and tighten the bolts.

ADJUSTABLE SEAT LEVER (OPTION)

The adjustable seat lever option controls the front-to-rear position of the seat. Pull the lever out, slide the seat backward or forward to the desired position and release the lever.

SEAT SUPPORT LEVER

The seat support lever locks the seat support down. To raise the seat support, pull the lever and seat support back. To lower the seat support, hold on to the lever and lower the seat support. Do not let the seat support drop or machine damage may occur.

SIDE BRUSH AND HOPPER LEVER

The side brush and hopper lever controls side brush rotation and hopper position. To start the side brush turning, push the lever forward into the "ON" position. To stop the side brush, pull the lever back into the "LOWER" position. To raise the hopper, pull the lever back into the "LIFT" position. To hold the hopper in any raised position, pull the lever back into the "HOLD" position. To lower the hopper, push the lever forward into the "LOWER" position.

THROTTLE LEVER

The throttle lever control is spring loaded into forward "ON" position. To stop the engine, pull the lever back into the "OFF" position.

TEMP LIGHT

The temp light indicates when the engine is overheating. If the light glows, stop the engine immediately and determine the cause. Failure to stop the engine will result in engine damage.

Engine overheating may happen because of low coolant level, a clogged radiator or cooling fins, a loose fan belt, or other engine malfunctions. Engine overheating will always cause coolant loss. If coolant loss does not occur, check for a defective temperature sending unit.

AMPS LIGHT

The amps light indicates when the electrical system is not operating properly. If the light glows, stop the engine and determine the cause.

The electrical system may not be accepting or getting a charge from the alternator. Overcharging and undercharging are indications that one or more electrical components are in need of repair.

OIL PRESSURE LIGHT

The engine oil pressure light indicates inadequate engine oil pressure. If the light glows, stop the engine immediately and determine the cause. Failure to stop the engine will result in engine damage.

HOPPER DOOR SWITCH

The hopper door switch controls the hopper door. To open the hopper door, press and hold the switch in the "OPEN" position until a ratcheting noise is heard. To close the hopper door, press and hold the switch in the "CLOSE" position until a ratcheting noise is heard. The hopper door should always be open except when high dumping the hopper.

LIGHT SWITCH

The light switch operates the head lights and the tail lights. To operate the lights, move the switch to the "ON" position. To turn off the lights, move the switch to the "OFF" position.

KEY-OPERATED IGNITION SWITCH

The key-operated ignition switch has four positions: "PREHEAT," "OFF," "ON," and "START." To start the engine, turn the key counterclockwise to the "PREHEAT" position until the glow plug indicator glows brightly - usually 15 to 30 seconds. Then turn key fully clockwise to the "START" position. Release the key as soon as the engine starts and the key will return to the "ON" position. To stop the engine, turn the key to the "OFF" position.

FOR SAFETY: Before Starting Machine, Make Sure All Safety Devices Are In Place And Operate Properly.

MAIN BRUSH LEVER

The main brush lever controls the position and the drive of the main brush. To raise the main brush, push the lever all the way forward into the "UP" position. To lower the main brush, push the lever forward and to the left, and release it.

When parking the machine, always raise the brush to prevent the bristles from taking a set.

GLOW PLUG INDICATOR

The glow plug indicator glows brightly when the preheaters are up to starting temperature.

To use engine preheaters, turn and hold the ignition key to the "preheat" position until the indicator glows brightly - usually 15 to 30 seconds. Then start the engine.

VACUUM LEVER

The vacuum lever controls the vacuum that is applied to the hopper. The lever also controls the dust filter shaker. When sweeping dry debris, place the lever in the "Normal Sweeping" position. When sweeping wet debris, place the lever in the "Wet Sweeping" position. To shake the dust filter, place and hold the lever in the "Filter Shaker" position for 20 seconds.

HOUR METER

The hour meter records the number of hours the machine has operated. This information is useful in determining when to service the machine.

FUEL LEVEL GAUGE

The fuel level gauge on a diesel powered machine indicates how much fuel is left in the fuel tank.

FLASHER SWITCH

The flasher switch is present on machines with the flashing light option. To operate the flashing light, move the switch to the "ON" position. To stop the light, move the switch to the "OFF" position.

STEERING WHEEL

The steering wheel controls the rear caster wheel. The machine is very responsive to the movement of the steering wheel. The operator should use care until he or she becomes experienced in guiding the machine.

HORN BUTTON

The horn button operates the machine horn. It is located to the left of the foot brake pedal.

OPERATION

SIDE BRUSH LEVER

The side brush lever controls the position of the side brush. To raise the side brush, pull the lever into the "Raised" position. To lower the brush, push the lever down and release it into the "Down" position.

When the machine is parked, always raise the brush to prevent the bristles from taking a set.

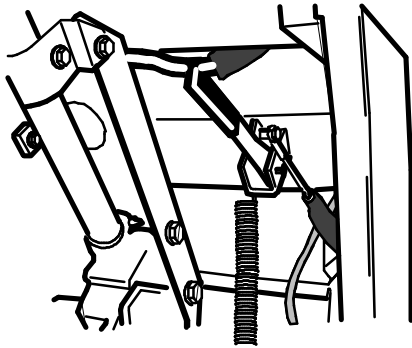

SIDE BRUSH LEVER

03396

SIDE BRUSH ADJUSTMENT KNOB

The side brush adjustment knob controls the height of the side brush when it is in the "Down" position. To reduce the brush pattern and the side brush contact with the floor, turn the knob to the right. To increase the brush pattern and the side brush contact with the floor, turn the knob to the left.

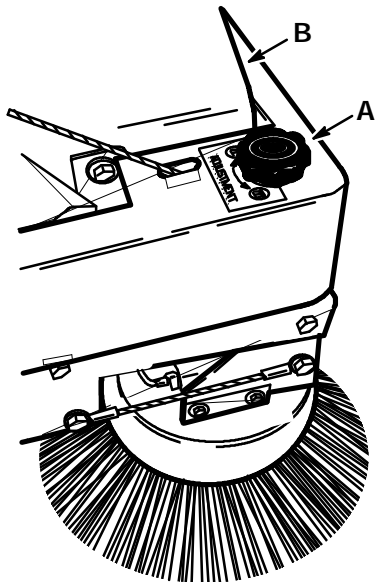

SIDE BRUSH ADJUSTMENT KNOB

03386

- A. Side Brush Adjustment Knob
- B. Hopper

AUXILIARY SIDE BRUSH IN-OUT SWITCH (OPTION)

The auxiliary side brush in-out switch controls the in and out movement of the auxiliary side brush option. To move the brush in, press the top of the in-out switch. To move the brush out, press the bottom of the in-out switch.

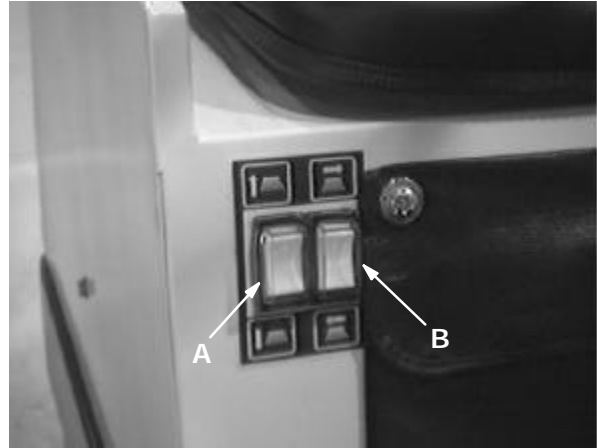

AUXILIARY SIDE BRUSH SWITCHES

- A. Up-Down Switch
- B. In-out Switch

AUXILIARY SIDE BRUSH UP-DOWN SWITCH (OPTION)

The auxiliary side brush up-down switch controls the up and down movement of the auxiliary side brush option. To raise the brush, press the top of the up-down switch. To lower the brush, press the bottom of the up-down switch.

CIRCUIT BREAKERS

Circuit breakers are resettable circuit protection devices designed to stop the flow of current in the event of a circuit overload. Once tripped, circuit breakers must be manually reset. If the overload which caused the circuit breaker to trip is still present in the circuit, the circuit breaker will continue to stop current flow until the overload is corrected.

The circuit breakers are located on the instrument panel bracket under the seat support.

The following chart shows the various circuit breakers and the electrical components they protect.

PROTECTIVE DEVICE	RATING	CIRCUIT PROTECTED
CB-1	15 A	Controls
CB-2	10 A	Horn
CB-3	10 A	Filter Shaker
CB-4	10 A	Hopper Dump Door
CB-5	7 A	Hopper Dump Door, Thermo Sentry™ and Air Flow Solenoids
CB-6	15 A	Lights

HOPPER SUPPORT BAR

The hopper support bar is located on the right side lift arm. It holds the hopper in a raised position to allow work to be done under the hopper. Do not rely on the machine hydraulic system to keep the hopper raised.

! WARNING: Raised Hopper May Fall. Engage Hopper Support Bar.

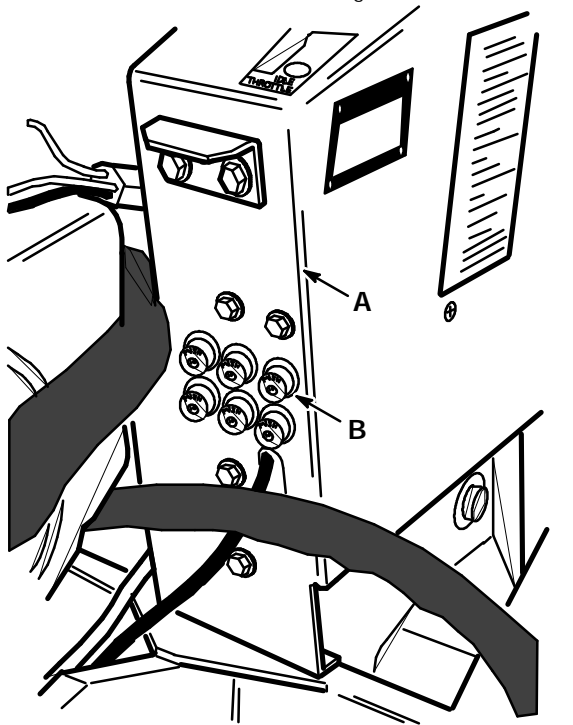

CIRCUIT BREAKERS

- A. Instrument Panel Bracket**
- B. Circuit Breakers**

MACHINE OPERATION**NORMAL SWEEPING OPERATION**

A normal sweeping operation consists of seven typical operations: pre-start checklist, starting machine, sweeping, dumping hopper, post operation checklist - engine operating, stopping machine, and post operation checklist - engine stopped.

The *PRE-START CHECKLIST* lists things to check before starting the machine.

TO START MACHINE lists the steps required to start the machine.

TO SWEEP lists things to keep in mind before and during the sweeping operation.

TO DUMP HOPPER lists the steps required to dump the hopper.

POST OPERATION CHECKLIST - ENGINE OPERATING lists things to check before stopping the machine engine.

TO STOP MACHINE lists the steps required to stop the machine.

The *POST OPERATION CHECKLIST - ENGINE STOPPED* lists things to check after stopping the machine engine.

PRE-START CHECKLIST

Check under the machine for leak spots.

Check the engine lubricating oil level.

Check the fuel level.

Check the brakes and controls for proper operation.

Check the service records to determine service requirements.

TO START MACHINE

NOTE: Before starting machine, perform the pre-start checks.

1. Turn the ignition switch key to the "PREHEAT" position until the glow plug indicator glows brightly.
2. The machine operator must be in the operator's seat with the directional pedal in the "neutral" position and with a foot on the brake pedal or with the parking brake set.

FOR SAFETY: Before Starting Machine; Make Sure All Safety Devices Are In Place And Operate Properly, Check Brakes And Steering For Proper Operation.

3. Turn the ignition switch key to the "START" position until the engine starts. Then release the key to the "on" position.

NOTE: Do not operate the starter motor for more than 10 seconds at a time or after the engine has started. Allow the starter to cool between starting attempts. The starter motor may be damaged if it is operated incorrectly.

4. Allow the engine and hydraulic system to warm up three to five minutes.
5. Release the machine parking brake.
6. Move the throttle control lever to the "FULL" position, and drive the machine to the area to be swept.

TO SWEEP

Plan the sweeping in advance. Try to arrange long runs with minimum stopping and starting. Sweep debris from very narrow aisles into main aisles ahead of time. Do an entire floor or section at one time. Overlap brush paths.

Pick up oversize debris before sweeping. Flatten or remove bulky cartons from aisles before sweeping. Pick up pieces of wire, twine, string, etc., which could become entangled in brush or brush plugs. Place large debris in hopper through hopper inspection door.

Avoid turning the steering wheel too sharply when the machine is in motion. The machine is very responsive to the movement of the steering wheel. Avoid sudden turns, except in emergencies.

Sweep as straight a path as possible. Avoid bumping into posts or scraping the sides of the sweeper.

1. Move the vacuum lever to the "Normal Sweeping" position to sweep dry debris, or "Wet Sweeping" position to sweep wet debris.
2. Push the main brush lever forward and to the left, then release the lever to lower the main brush.
3. Move the side brush lever into the "Down" position.
4. Push the side brush and hopper lever into the "ON" position.
5. Press and hold the hopper door switch in the "OPEN" position.
6. Sweep as required.

TO DUMP HOPPER

1. Push the main brush lever into the "UP" position.
2. Pull the side brush lever into the "Raised" position.
3. Move the vacuum lever to the "Filter Shaker" position for 20 seconds to shake the dust filter.
4. Slowly drive the machine up to the dump site or dumpster.
5. Press and hold the hopper door switch in the "CLOSE" position.
6. Pull the side brush and hopper lever to the "LIFT" position, then into the "HOLD" position when at the desired dump height.
7. Press and hold the hopper door switch in the "OPEN" position to dump the hopper.
8. Press and hold the hopper door switch in the "CLOSE" position to close the hopper door.
9. Slowly back the machine away from the dump site or dumpster.
10. Push the side brush and hopper lever to the "LOWER" position to lower the hopper.
11. Press and hold the hopper door switch in the "OPEN" position to open the hopper door.

POST OPERATION CHECKLIST - ENGINE OPERATING

Check brush patterns for width and evenness.

OPERATION

TO STOP MACHINE

1. Return the directional pedal to the "neutral" position. Apply the brake.
2. Push the main brush lever into the "UP" position.
3. Pull the side brush lever back into the "Raised" position.
4. Pull the side brush and hopper lever into the "LOWER" position to stop the side brush.
5. Set the machine parking brake.
6. Pull the throttle control lever in the "STOP" position.
7. Turn the key-operated ignition switch key to the "OFF" position. Remove the key from the ignition switch.

FOR SAFETY: Before Leaving Or Servicing Machine; Stop On Level Surface, Set Parking Brake, Turn Off Machine And Remove Key.

POST OPERATION CHECKLIST - ENGINE STOPPED

Check the skirts for damage, wear, and adjustment.

Check for wire or string tangled on the brushes.

Check for leaks.

TO ENGAGE HOPPER SUPPORT BAR

WARNING: Raised Hopper May Fall. Engage Hopper Support Bar.

1. Set the machine parking brake.

FOR SAFETY: Before Leaving Or Servicing Machine; Stop On Level Surface, Set Parking Brake, Turn Off Machine And Remove Key.

2. Raise the hopper.
3. Position the hopper support bar on the bar stand.

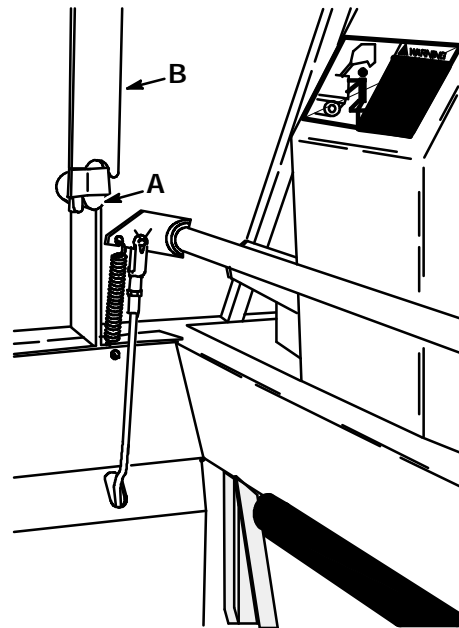

HOPPER SUPPORT BAR STAND

03369

- A. Bar Stand
- B. Support Bar

4. Slowly lower the hopper so the bar is secure.

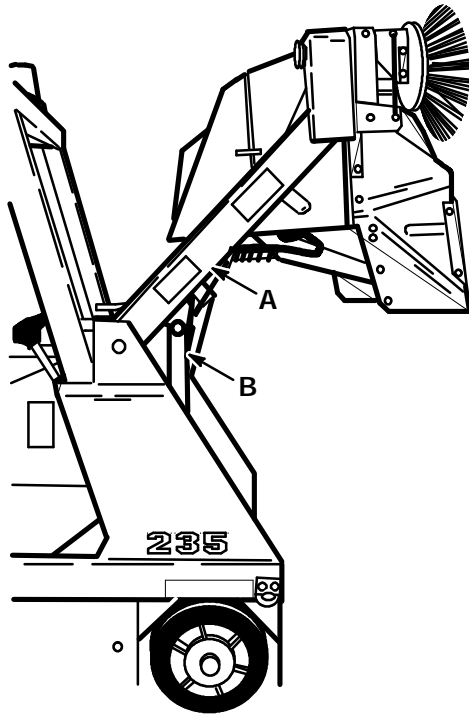

OPERATION ON GRADES

Drive the machine slowly on grades. Use the brake pedal to control machine speed.

FOR SAFETY: When Using Machine, Go Slow On Grades And Slippery Surfaces.

The maximum rated climb and descent angle is 10°.

ENGAGED HOPPER SUPPORT BAR

03370

- A. Lift Arm
- B. Support Bar

TO DISENGAGE HOPPER SUPPORT BAR

1. Raise the hopper.
2. Place the support bar in its storage position.
3. Lower the hopper.

MACHINE TROUBLESHOOTING

Problem	Cause	Remedy
Excessive dusting	Dust skirts and seals worn, damaged, not adjusted properly	Replace or adjust skirts or seals
	Dust filter clogged	Shake and clean or replace filter
	Vacuum hose damaged	Replace vacuum hose
	Vacuum fan failure	Belt loose, broken or off sheave
Poor sweeping performance	Brush bristles worn	Replace brushes
	Brushes not adjusted properly	Adjust brushes
	Debris caught in brush drive mechanism	Free mechanism of debris
	Main brush drive failure	Belt loose, broken or off sheave
	Side brush drive failure	See <i>HYDRAULIC SYSTEM TROUBLESHOOTING</i> : Side brush turns slowly or not at all
	Hopper not adjusted properly	Adjust hopper floor clearance
	Hopper dump door closed	Open dump door
	Hopper full	Empty hopper
	Hopper floor skirts worn, damaged	Replace skirts

TRANSPORTING MACHINE

PUSHING OR TOWING MACHINE

The machine may be slowly pushed from the front or rear, pushing on the bumper or the machine frame.

The machine may be slowly towed from the front. Use care when attaching towing cables or chains to avoid damaging the machine.

MACHINE JACKING

The machine may be jacked up for service at the designated locations. Use a jack of adequate capacity and good working condition. Always stop the machine on a flat, level surface and block the tires before jacking the machine up.

The front jacking locations are on the flat bottom edge of the machine frame next to the front tires. The rear jacking location is the middle flat bottom edge of the rear bumper.

TO JACK UP MACHINE

1. Empty and lower the debris hopper.
2. Stop the engine and set the machine parking brake.

FOR SAFETY: Before Leaving Or Servicing Machine; Stop On Level Surface, Set Parking Brake, Turn Off Machine And Remove Key.

3. Block the tires, which are not being jacked up, in order to secure the machine position.

FOR SAFETY: When Servicing Machine, Block Machine Tires Before Jacking Machine Up.

4. Use a jack of adequate capacity to raise the machine. Jack up the machine only at the designated locations.

FOR SAFETY: When Servicing Machine, Use Hoist Or Jack Of Adequate Capacity To Lift Machine, Jack Machine Up At Designated Locations Only. Block Machine Up With Jack Stands.

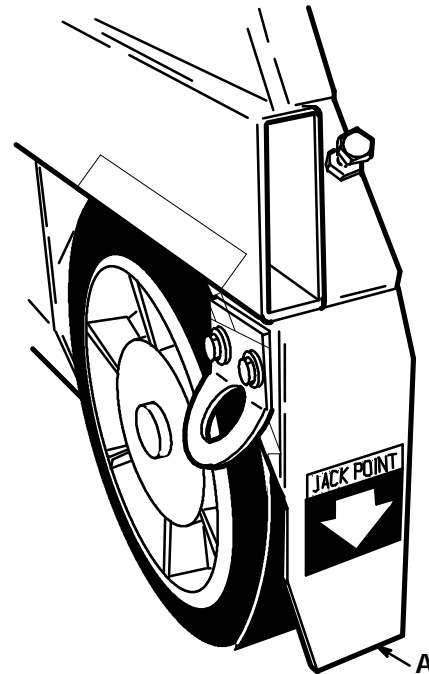

FRONT JACKING LOCATION

03372

A. Jacking Location

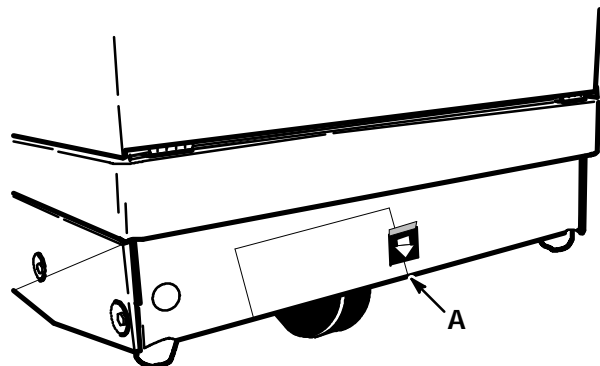

REAR JACKING LOCATION

03373

A. Jacking Location

5. Block machine up with jack stands or similar devices in the designated locations to secure the machine.

FOR SAFETY: When Servicing Machine, Jack Machine Up At Designated Locations Only. Block Machine Up With Jack Stands.

OPERATION

6. Lower the machine onto the jack stands.
7. Check to make sure the machine is secure.
8. Service the machine as required.
9. When finished servicing the machine, raise the machine off the jack stands.
10. Remove the jack stands from under the machine.
11. Lower the machine.
12. Remove the blocks from the tires.

MACHINE TIE-DOWNS

The machine may be tied down at each corner of the main frame using the tie-down brackets supplied in the tie-down kit.

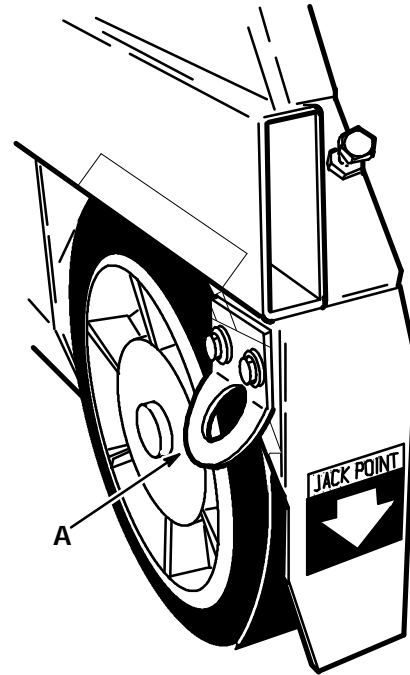

03372

FRONT TIE-DOWN LOCATION

A. Tie-Down Bracket

When transporting the machine on a trailer or in a truck, be sure to set the machine parking brake and block the machine tires to prevent the machine from rolling.

MACHINE STORAGE

STORING MACHINE

When storing the machine for extended periods of time, the following procedures must be followed to lessen the chance of rust, sludge, or other undesirable deposits from forming.

1. Empty the debris hopper.
2. Change the engine oil.
3. Raise the main brush and side brush.
4. Park the machine on a level surface in a cool, dry area.
5. Stop the engine and set the machine parking brake.
6. Fill the hydraulic reservoir with hydraulic fluid to prevent excessive condensation from forming.
7. To store the machine 30 to 90 days:
 - A. Drain the coolant from the radiator and engine block.
 - B. Close the engine cooling system drain cocks.

To store the machine 90 days to 6 months also:

- C. Seal the air cleaner inlet and the exhaust outlet with weatherproof masking tape.
- D. Tighten the engine oil filler cap, the fuel tank cap, and the radiator cap to make certain they are securely in place.

SECTION 3

CONTENTS

	Page		Page
RECOMMENDED FIRST 50-HOUR		VACUUM FAN BELT	3-26
MACHINE INSPECTION	3-3	TO REPLACE AND ADJUST	
MAINTENANCE CHART	3-4	VACUUM FAN BELT	3-26
LUBRICATION	3-6	MAIN BRUSH BELT	3-28
ENGINE	3-6	TO REPLACE MAIN BRUSH BELT .	3-28
SIDE BRUSH LEVER PIVOT	3-6	FAN BELT	3-28
REAR WHEEL SUPPORT BEARING ..	3-7	TO REPLACE AND ADJUST	
STEERING LINKAGE	3-7	FAN BELT	3-28
HYDRAULICS	3-8	TAPER LOCK BUSHINGS	3-30
HYDRAULIC FLUID	3-8	TO REMOVE TAPER	
HYDRAULIC FLUID RESERVOIR	3-8	LOCK BUSHING	3-30
HYDRAULIC FILTER	3-8	TO INSTALL TAPER	
TO REPLACE FILTER ELEMENT ..	3-9	LOCK BUSHING	3-30
HYDRAULIC PUMPS	3-9	STATIC DRAG CHAIN	3-30
TO START AND BREAK-IN		DEBRIS HOPPER AND DUST FILTER ...	3-31
HYDRAULIC PUMP	3-9	DEBRIS HOPPER	3-31
DIRECTIONAL PEDAL	3-10	TO CHECK AND ADJUST HOPPER	
TO ADJUST DIRECTIONAL		FLOOR CLEARANCE	3-31
PEDAL LINKAGE	3-10	THERMO SENTRY™	3-31
LIFT ARM SPEED LIMITER	3-11	TO CHECK THE	
HYDRAULIC FLUID LEAKS	3-12	THERMO SENTRY™	3-31
HYDRAULIC SCHEMATIC	3-13	HOPPER DUST FILTER	3-32
HYDRAULIC SYSTEM		TO REMOVE AND REPLACE	
TROUBLESHOOTING	3-14	HOPPER DUST FILTER	3-33
HYDRAULIC COMPONENTS		BRUSHES	3-34
TROUBLESHOOTING	3-15	MAIN BRUSH	3-34
ENGINE	3-16	TO REMOVE MAIN BRUSH	3-34
ENGINE LUBRICATION	3-16	TO INSTALL MAIN BRUSH	3-34
COOLING SYSTEM	3-16	TO CHECK AND ADJUST MAIN	
AIR INTAKE SYSTEM	3-17	BRUSH PATTERN	3-34
AIR FILTER	3-18	SIDE BRUSH	3-36
TO REPLACE AIR		TO REMOVE SIDE BRUSH	3-36
FILTER ELEMENT	3-18	TO INSTALL SIDE BRUSH	3-36
FUEL SYSTEM	3-19	SKIRTS AND SEALS	3-37
FUEL SYSTEM	3-19	BRUSH SKIRTS	3-37
FUEL WATER TRAP FILTER	3-19	TO REPLACE AND ADJUST	
TO REPLACE FUEL		BRUSH SKIRTS	3-37
FILTER ELEMENT	3-19	REAR SKIRTS	3-37
PRIMING FUEL SYSTEM	3-20	TO REPLACE AND ADJUST	
TO PRIME FUEL SYSTEM	3-20	REAR SKIRTS	3-37
DIESEL FUEL TROUBLESHOOTING ..	3-21	HOPPER LIP SKIRT	3-38
CYLINDER HEAD	3-22	TO REPLACE HOPPER LIP SKIRT .	3-38
CYLINDER HEAD	3-22	DUST SEALS	3-38
VALVE CLEARANCE	3-22	TO REPLACE DUST SEALS	3-38
DECOMPRESSION LEVER	3-22	HOPPER DUMP DOOR SEAL	3-39
ELECTRICAL SYSTEM	3-23	TO REPLACE HOPPER DUMP	
BATTERY	3-23	DOOR SEAL	3-39
ELECTRICAL SCHEMATIC	3-24	VACUUM FAN SEAL	3-40
ELECTRICAL SCHEMATIC,		FILTER COVER SEAL	3-40
AUXILIARY SIDE BRUSH	3-25	BRAKES AND TIRES	3-41
BELTS AND CHAINS	3-26	BRAKES	3-41
HYDRAULIC PUMP BELT	3-26	TIRES	3-41
TO REPLACE AND ADJUST		REAR WHEEL	3-41
HYDRAULIC PUMP BELT	3-26		

RECOMMENDED FIRST 50-HOUR MACHINE INSPECTION

After the first 50 hours of operation, the following procedures are recommended:

1. Check the floor skirts to floor clearance. See *SKIRTS AND SEALS*.
2. Check the side brush and main brush patterns. See *BRUSHES*.
3. Change the engine oil after the first 35 hours of operation.
4. Replace hydraulic fluid filter element.
5. Torque the rear wheel nuts in a star pattern to 122 to 150 Nm (90 to 110 ft lb). See *REAR WHEEL*.
6. Perform all 50-hour interval lubrication and maintenance procedures listed in the *MAINTENANCE CHART*.

MAINTENANCE CHART

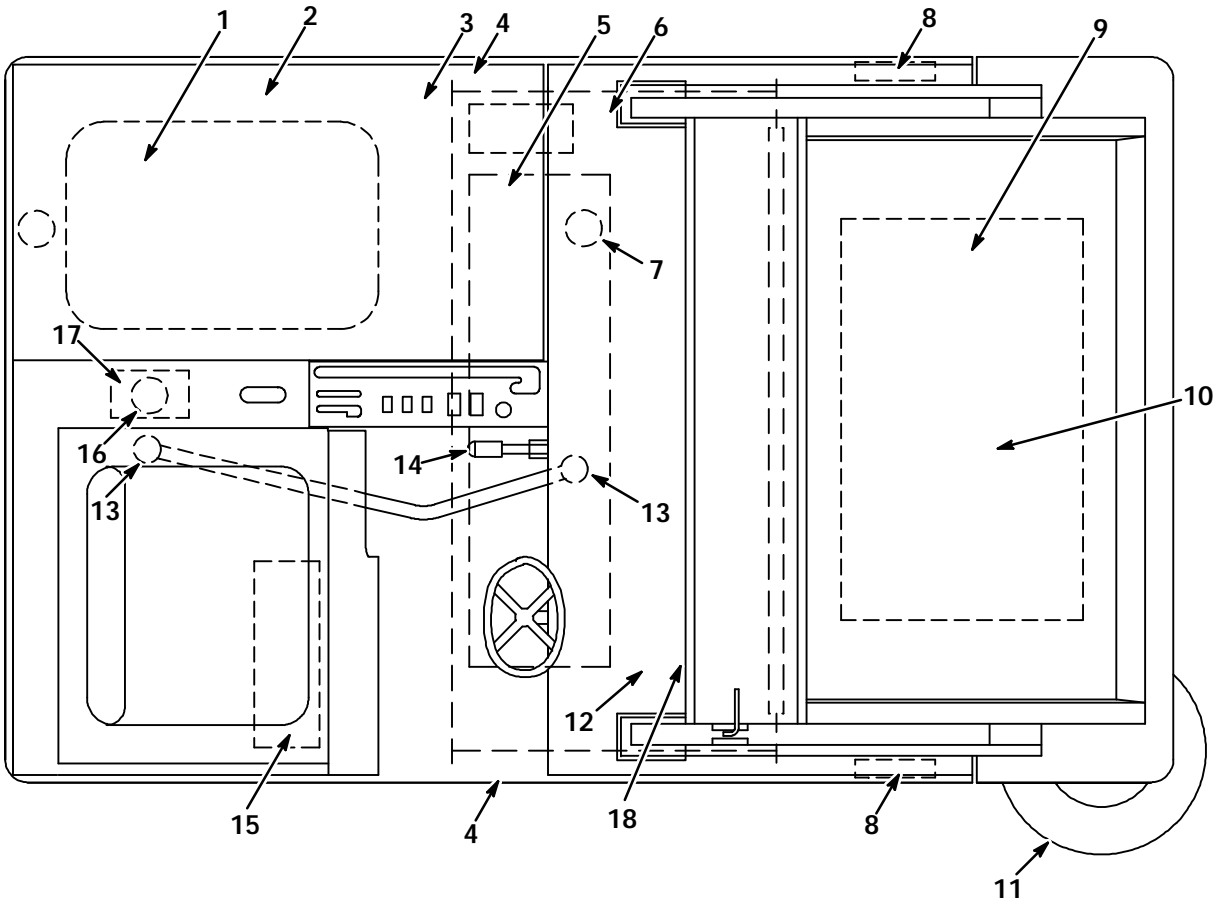

03488

Interval	Key	Description	Procedure	Lubricant	No. of Service Points
Daily	1	Engine	Check oil level	EO	1
			Drain fuel water trap	-	1
			Empty air filter dust cap	-	1
	4	Brush and rear skirts	Check for damage and wear	-	4
	18	Hopper lip skirt	Check for damage and wear	-	1
Daily	5	Main brush	Check for damage and wear	-	1
	11	Side brush	Check for damage and wear	-	1
	50 Hours	5	Main brush	Rotate end-for-end	-

MAINTENANCE

Interval	Key	Description	Procedure	Lubricant	No. of Service Points
100 Hours	1	Engine	Clean or replace air filter element	-	1
			Change oil and oil filter	EO	1
			Check radiator coolant level	WG	1
			Clean or replace radiator pre-screen	-	1
	3	Dust Seals	Check for damage and wear	-	6
	9	Dust filter	Clean or replace	-	1
	15	Hydraulic reservoir	Check fluid level	HYDO	1
	10	Thermo Sentry™	Test	-	1
17	Rear tire	Check pressure and wear	-	1	
8	Front tires	Inspect for wear	-	2	
200 Hours	1	Engine	Change coolant	WG	1
			Check fan belt tension	-	1
	6	Vacuum fan belt	Check tension	-	1
	2	Hydraulic pump belt	Check tension	-	1
	12	Side brush lever pivot	Lubricate	SPL	1
	14	Parking brake	Check adjustment	-	1
	16	Rear wheel support bearing	Lubricate	SPL	1
13	Steering linkage	Lubricate	SPL	2	
400 Hours	1	Engine	Replace fuel filter element	-	1
	15	Hydraulic fluid reservoir	Change hydraulic fluid	HYDO	1
	7	Hydraulic fluid filter	Change filter element	-	1
800 Hours	17	Rear wheel	Torque wheel nuts	-	1

EO - Engine oil

HYDO - TENNANT or approved hydraulic fluid

SPL - Special lubricant, Lubriplate EMB grease (TENNANT part number 01433-1)

WG - Water and permanent-type ethylene glycol anti freeze, one-to-one ratio

NOTE: More frequent intervals may be required in extremely dusty conditions.

LUBRICATION**ENGINE**

Check the engine oil level daily.

Change the engine oil and oil filter after the first 35 hours of operation and then after every 100 hours of operation. Use a straight SAE 20-weight, API class CD engine oil when ambient temperatures range from 32 to 77° F (0 to 25° C). Use a straight SAE 30-weight, API class CD engine oil when ambient temperatures are above 77° F (25° C). If multiviscosity oil is preferred, use SAE 10W-30 weight, API class CD engine oil for all temperatures. The engine oil capacity is 3.2 qt (3 L).

SIDE BRUSH LEVER PIVOT

The side brush lever pivot allows the side brush lever to move freely. Lubricate the pivot with Lubriplate EMB grease (TENNANT part number 01433-1) after every 200 hours of operation.

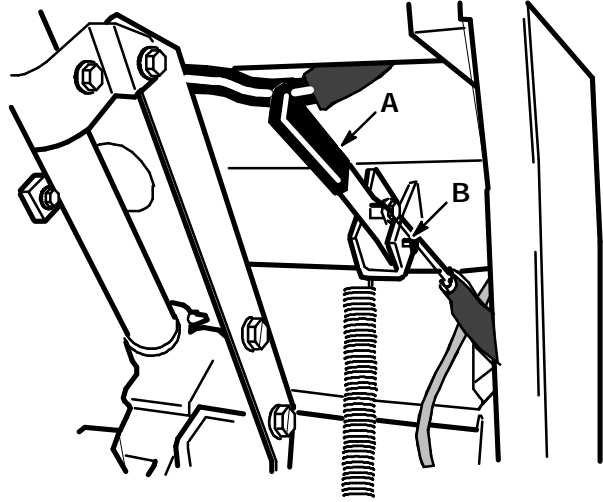

03396

SIDE BRUSH LEVER PIVOT

- A. Side Brush Lever**
- B. Pivot**

REAR WHEEL SUPPORT BEARING

The rear wheel support bearing allows the rear wheel assembly to rotate freely. It is lubricated with Lubriplate EMB grease (TENNANT part number 01433-1). Apply the lubricant with a hand grease gun after every 200 hours of operation.

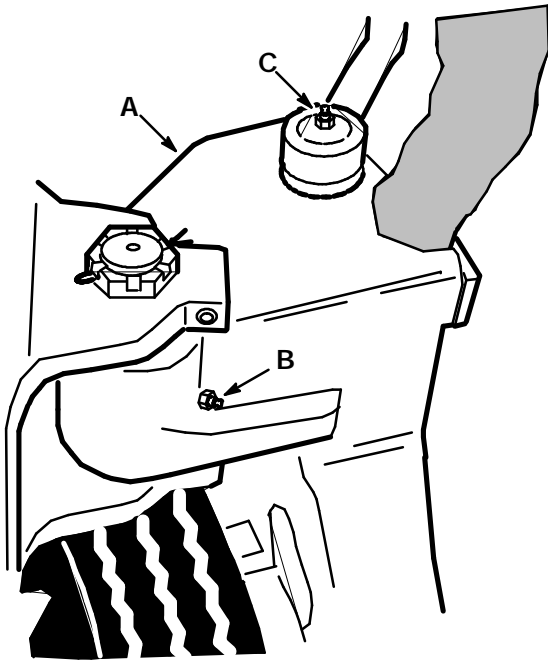

REAR WHEEL SUPPORT BEARING

03501

- A. Rear Wheel Support
- B. Support Grease Fitting
- C. Rear Steering Link Grease Fitting

STEERING LINKAGE

The steering linkage controls machine steering. A grease fitting is located on each of the two linkage ball joints for lubrication. The linkage should be lubricated by applying Lubriplate EMB grease (TENNANT part number 01433-1) to the grease fittings after every 200 hours of operation.

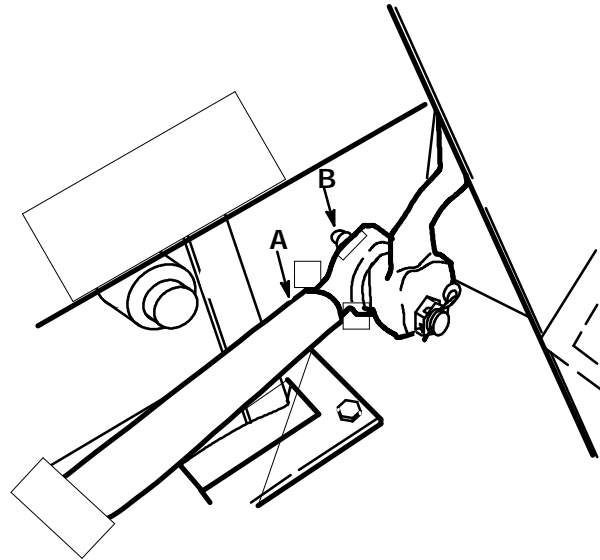

FRONT STEERING LINK

03394

- A. Steering Link
- B. Grease Fitting

HYDRAULICS

HYDRAULIC FLUID

The quality and condition of the hydraulic fluid play a very important role in how well the machine operates. TENNANT's hydraulic fluid is specially selected to meet the needs of TENNANT machines.

TENNANT's hydraulic fluids provide a longer life for the hydraulic components. There is one recommended fluid.

TENNANT part no.	Fluid Weight
65870	5-20W

If a locally-available hydraulic fluid is used, make sure the specifications match TENNANT hydraulic fluid specifications. Using substitute fluids can cause premature failure of hydraulic components.

European marketed machines are filled with locally available hydraulic fluids. Check the label on the hydraulic fluid reservoir.

ATTENTION! Hydraulic components depend on system hydraulic fluid for internal lubrication. Malfunctions, accelerated wear, and damage will result if dirt or other contaminants enter the hydraulic system.

HYDRAULIC FLUID RESERVOIR

Hydraulic fluid is stored in the hydraulic fluid reservoir. It holds 3.9 gal (14.8 L) of hydraulic fluid. The reservoir is located under the seat support.

The fluid level is checked by looking at the dipstick on the breather-filler cap with the hopper in the sweeping position. The reservoir is full when the fluid level is above the "ADD" mark on the dipstick.

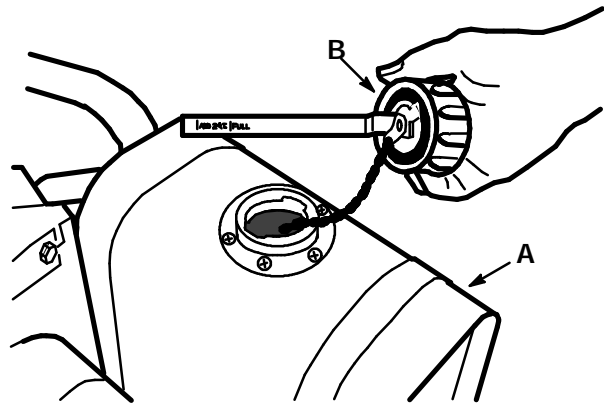

HYDRAULIC FLUID RESERVOIR

03502

- A. Reservoir**
- B. Breather-Filler Cap**

Check the hydraulic fluid level at operating temperature every 100 hours of operation. Change the hydraulic fluid after every 400 hours of operation. Do not overfill the hydraulic fluid reservoir. Hydraulic fluid expands as it heats to its normal operating temperature. Always allow for expansion when filling the reservoir. Lubricate the filler cap gasket with a film of hydraulic fluid before putting the cap back on the reservoir.

HYDRAULIC FILTER

The hydraulic fluid filter keeps the machine hydraulic system clean to a level of 10 microns. The hydraulic fluid filter is located next to the vacuum fan.

Replace the hydraulic fluid filter element after the first 50 hours of operation and then after every 400 hours of operation.

TO REPLACE FILTER ELEMENT

1. Stop the engine and set the machine parking brake.

FOR SAFETY: Before Leaving Or Servicing Machine; Stop On Level Surface, Set Parking Brake, Turn Off Machine And Remove Key.

2. Open the seat support.

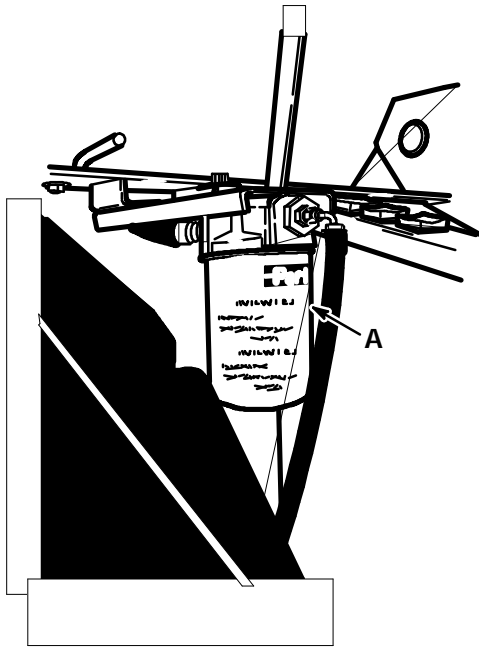

HYDRAULIC FLUID FILTER

03395

A. Filter Element

3. Unthread and discard the hydraulic fluid filter element.
4. Apply a thin coat of hydraulic fluid to the seal of the new hydraulic fluid filter element.
5. Thread and hand tighten the new hydraulic fluid filter element on the filter head.
6. Close the seat support.
7. Operate the machine and check for leaks. Correct any leaks found.
8. Check the hydraulic fluid reservoir level and fill as required.

HYDRAULIC PUMPS

The machine propelling pump is a variable displacement hydraulic piston pump. It is driven by the engine via a dual belt.

The machine accessories pump is a hydraulic gear pump. It is driven by a belt from the propelling pump sheave.

After repairing or replacing a hydraulic pump, or when system contamination is likely, change the hydraulic fluid in the reservoir and the hydraulic fluid filter. Then the proper start and break-in procedure must be followed to prevent possible damage to the pump. Replace the hydraulic fluid filter after the first hour of operation. *TO START AND BREAK-IN HYDRAULIC PUMP* outlines the procedure.

TO START AND BREAK-IN HYDRAULIC PUMP

1. Stop the engine, set the machine parking brake and block the front tires of the machine.

FOR SAFETY: Before Leaving Or Servicing Machine; Stop On Level Surface, Set Parking Brake, Turn Off Machine And Remove Key.

2. Jack up the rear of the machine at the designated locations.

FOR SAFETY: When Servicing Machine, Block Machine Tires Before Jacking Machine Up.

3. Block up the machine with jack stands in the designated locations. Make sure the rear tire clears the floor by 2 in (50 mm) and all obstacles within a 24 in (610 mm) radius.

FOR SAFETY: When Servicing Machine, Jack Machine Up At Designated Locations Only. Block Machine Up With Jack Stands.

4. Fill the hydraulic fluid reservoir with 3 gal (11 L) of new, approved hydraulic fluid.
5. Fill the hydraulic pump through the case drain port with hydraulic fluid.
6. Remove the engine coil wire from the engine distributor or turn off fuel flow.
7. Operate the engine starter motor for three 10 second periods.

8. Replace the engine coil wire.
9. Start the engine and operate it at an idle for two minutes.
10. Press the directional pedal one-half of its travel in the "forward" direction while also operating the main brush and side brush for one minute.
11. Adjust the directional pedal as described in *TO ADJUST DIRECTIONAL PEDAL LINKAGE*.
12. Stop the engine.
13. Raise the rear of the machine, remove the jack stands, and lower the machine.
14. Fill the hydraulic fluid reservoir with new, approved hydraulic fluid.
15. Check the hose routings to be sure the hoses do not contact any moving, hot, or sharp surfaces.
16. Replace the hydraulic fluid filter after the first hour of operation.

DIRECTIONAL PEDAL

The directional pedal controls the flow of hydraulic fluid to the hydraulic drive motor. The pedal has three positions - "forward," "neutral," and "reverse." The "forward" and "reverse" positions send hydraulic fluid to the drive motor to propel the machine.

The "neutral" position is the position in which the propelling pump sends no hydraulic fluid to the propelling motor. The machine should not creep when the "neutral" position is correctly adjusted. Adjust the pedal linkages, as described in *TO ADJUST DIRECTIONAL PEDAL LINKAGE*, whenever the machine creeps or after replacing the hydraulic propelling pump or pump linkages. The pedal linkages should also be adjusted whenever the reverse speed is excessive or inadequate.

TO ADJUST DIRECTIONAL PEDAL LINKAGE

1. Stop the engine and set the machine parking brake.

FOR SAFETY: Before Leaving Or Servicing Machine; Stop On Level Surface, Set Parking Brake, Turn Off Machine And Remove Key.

2. Block the machine tires and jack up the rear of the machine at the designated location.

FOR SAFETY: When Servicing Machine, Block Machine Tires Before Jacking Machine Up.

3. Block up the machine with jack stands in the designated locations. Make sure the rear tire clears the floor by 2 in (50 mm) and all obstacles within a 24 in (610 mm) radius.

FOR SAFETY: When Servicing Machine, Jack Machine Up At Designated Locations Only. Block Machine Up With Jack Stands.

4. Loosen the two centering bolts jam nuts.

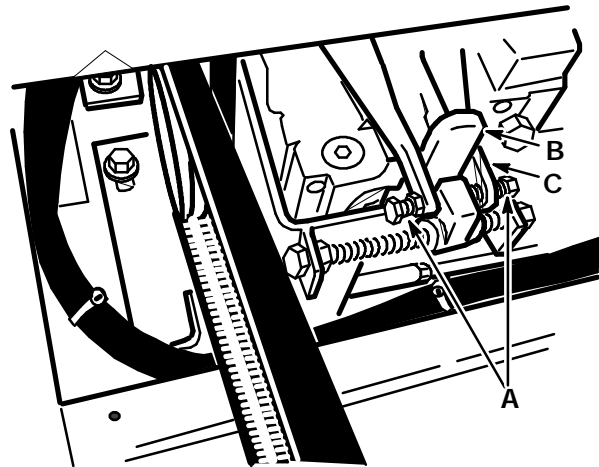

CENTERING BOLTS

- A. Adjustment Bolts
- B. Pintle Arm
- C. Centering Stop

03505

5. Start the engine.
6. Move the directional pedal into the "forward" position and release it. The rear wheel should stop rotating as soon as the pedal is released. Stop the engine and adjust the centering bolt as required.
7. Move the directional pedal into the "reverse" position and release it. The rear wheel should stop rotating as soon as the pedal is released. Stop the engine and adjust the centering bolt as required.

NOTE: If there is not enough adjustment in the centering bolts, reposition the centering stop.

8. Tighten the jam nuts.
9. Raise the rear of the machine, remove the jack stands, and lower the machine.
10. Adjust the position of the directional pedal ball joints so the pedal hits the floor when the directional pedal is pressed backward. The backward travel should be restricted so the machine will not travel faster than 3 mph (5 km/h) in reverse.
11. Tighten the directional pedal ball joints and jam nuts.

To adjust the limited speed, raise the hopper and engage the hopper support bar. Loosen the two bracket bolts and slide the bracket and cam forward to increase speed or slide the bracket backward to decrease speed. Tighten the bolts.

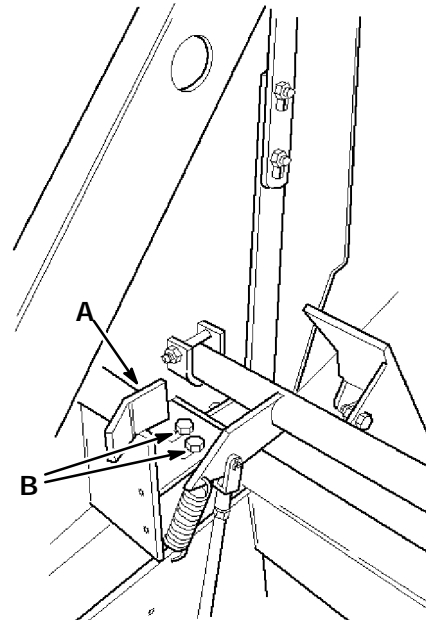

SPEED LIMITER LINK

03507

- A. Bracket and Cam**
- B. Bracket Bolts**

LIFT ARM SPEED LIMITER

The lift arm speed limiter limits the forward speed the machine can travel when the hopper is raised. The speed limiter should be adjusted whenever the pump control linkage is adjusted. The machine should travel 2 mph (3 km/h) with the hopper raised.

The speed limiter consists of a cam under the directional pedal with a link to the lift arms. When the hopper is raised, the link lifts the cam under the pedal. This limits how far the directional pedal can be pressed, limiting the machine speed.

HYDRAULIC FLUID LEAKS

Fluid escaping from a very small hole can be almost invisible. Use a piece of cardboard or wood, rather than hands, to search for suspected leaks.

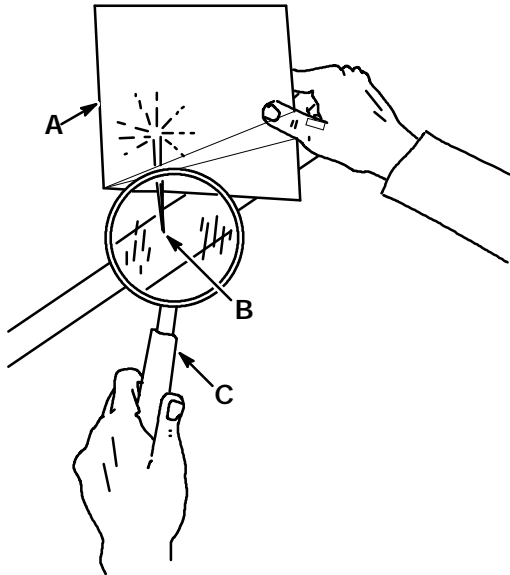

HYDRAULIC PINHOLE LEAK

00002

- A. Cardboard**
- B. Pinhole Leak**
- C. Magnifying Glass**

If injured by escaping hydraulic fluid, see a doctor at once. Serious infection or reaction can develop if proper medical treatment is not administered immediately.

FOR SAFETY: When Servicing Machine, Use Cardboard To Locate Leaking Hydraulic Fluid Under Pressure.

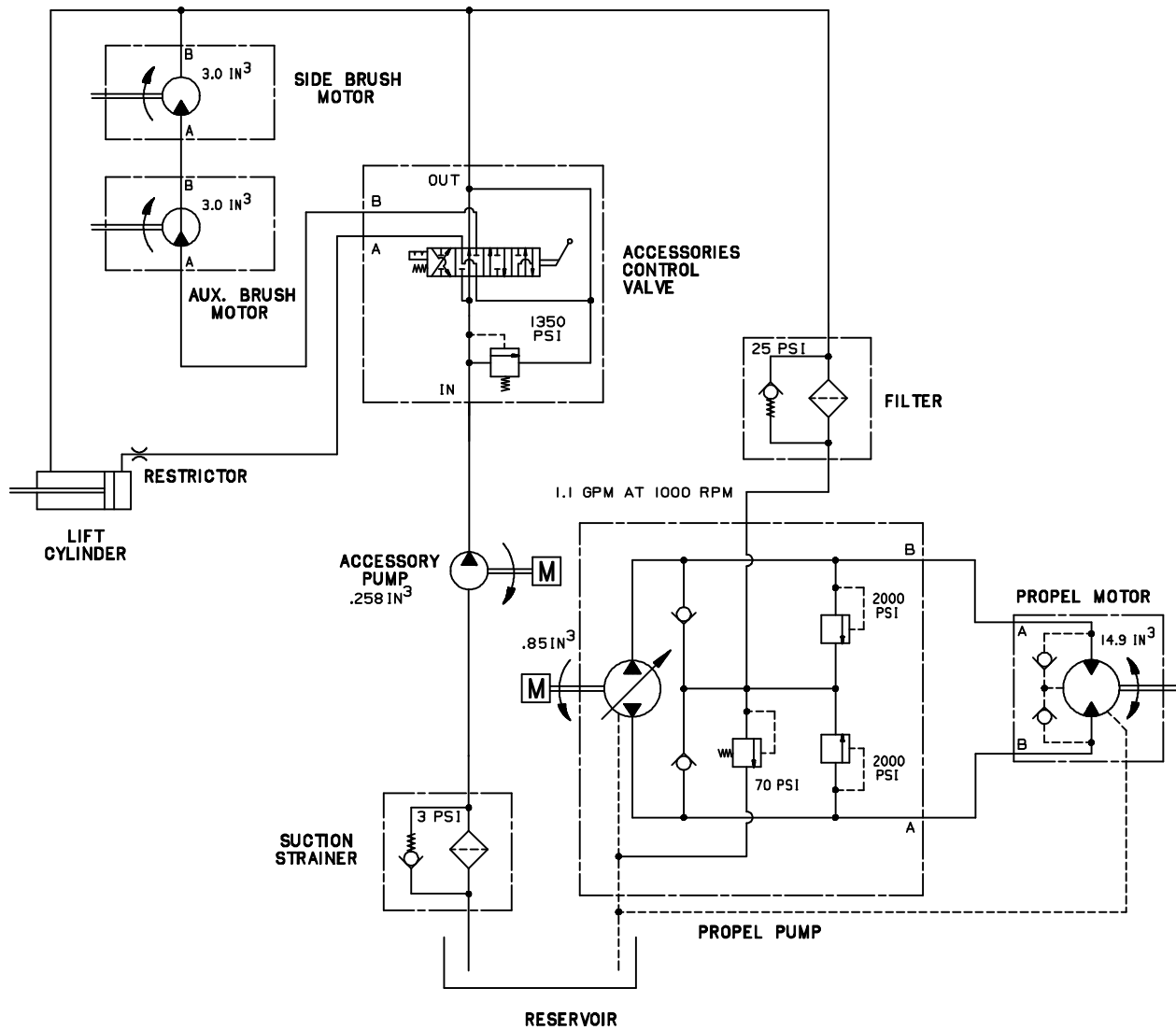

HYDRAULIC SCHEMATIC

03460

HYDRAULIC SYSTEM TROUBLESHOOTING

Problem	Cause	Remedy
Machine travels slowly or not at all	Parking brake set	Release parking brake
	Control linkage broken or not adjusted properly	Replace and/or adjust linkage
	Relief valve stuck open (leaking) valve	Clean or replace relief valve - one forward, one reverse
	Motor failure	See <i>HYDRAULIC COMPONENTS TROUBLESHOOTING</i> : Hydraulic motor failure
	Pump failure	See <i>HYDRAULIC COMPONENTS TROUBLESHOOTING</i> : Hydraulic piston pump failure
	Hydraulic fluid level low	Fill hydraulic fluid reservoir
Side brush turns slowly or not at all	Hydraulic control valve failure	See <i>HYDRAULIC COMPONENTS TROUBLESHOOTING</i> : Hydraulic control valve failure
	Hydraulic motor failure	See <i>HYDRAULIC COMPONENTS TROUBLESHOOTING</i> : Hydraulic motor failure
	Relief valve in control valve sticking	Clean or replace relief valve
	Gear pump failure	See <i>HYDRAULIC COMPONENTS TROUBLESHOOTING</i> : Hydraulic gear pump failure
Hopper will not lift	Hydraulic control valve failure	See <i>HYDRAULIC COMPONENTS TROUBLESHOOTING</i> : Hydraulic control valve failure
	Hydraulic orifice at lift cylinder plugged	Replace orifice
	Lift cylinder failure	See <i>HYDRAULIC COMPONENTS TROUBLESHOOTING</i> : Hydraulic cylinder failure
	Gear pump failure	See <i>HYDRAULIC COMPONENTS TROUBLESHOOTING</i> : Hydraulic gear pump failure
	Hopper overloaded	Empty hopper
	Lift arms binding	Replace and/or adjust lift arm linkage
Hopper will not lower	Lift cylinder failure	See <i>HYDRAULIC COMPONENTS TROUBLESHOOTING</i> : Hydraulic cylinder failure
	Lift arms binding	Replace and/or adjust lift arm linkage
	Hydraulic orifice at lift cylinder plugged	Replace orifice

HYDRAULIC COMPONENTS TROUBLESHOOTING

Problem	Cause	Remedy
Hydraulic cylinder failure	Piston seals leaking	Install seal kit
	Barrel worn or rod bent	Replace cylinder rod
Hydraulic control valve failure	Valve seals leaking	Install seal kit
	Relief valve stuck open (leaking)	Clean or replace relief valve
Hydraulic motor failure	Motor leaking	Install seal kit
	Drive link failure	Replace drive link
	Gerotor worn	Replace gerotor set
	Output shaft failure	Replace output shaft and bearings
Hydraulic gear pump failure	Pump leaking	Install seal kit
	Gear set failure	Replace gear set
	Shaft failure	Replace gear set
Hydraulic piston pump failure	Pump leaking	Install seal kit
	Relief valve stuck	Clean or replace relief valve
	Integral charge pump failure	Replace charge pump
	Rotating group worn	Replace rotating group
	Shaft failure	Replace shaft
	Backplate worn	Replace backplate
	Engine-to-pump coupling failure	Replace coupling

ENGINE

ENGINE LUBRICATION

Check the engine oil level daily.

Change the engine oil and oil filter after the first 35 hours of operation and then after every 75 hours of operation. Use a straight SAE 20-weight, API class CD engine oil when ambient temperatures range from 32 to 77° F (0 to 25° C). Use a straight SAE 30-weight, API class CD engine oil when ambient temperatures are above 77° F (25° C). If multiviscosity oil is preferred, use SAE 10W-30 weight, API class CD engine oil for all temperatures.

The engine oil capacity is 3.2 qt (3 L).

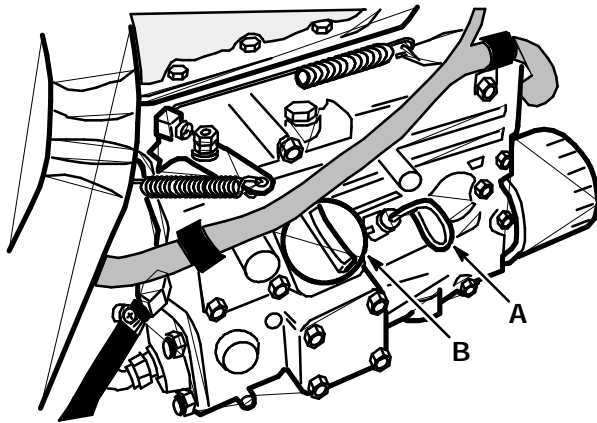

03509

DIPSTICK AND FILL CAP

- A. Dipstick
- B. Fill Cap

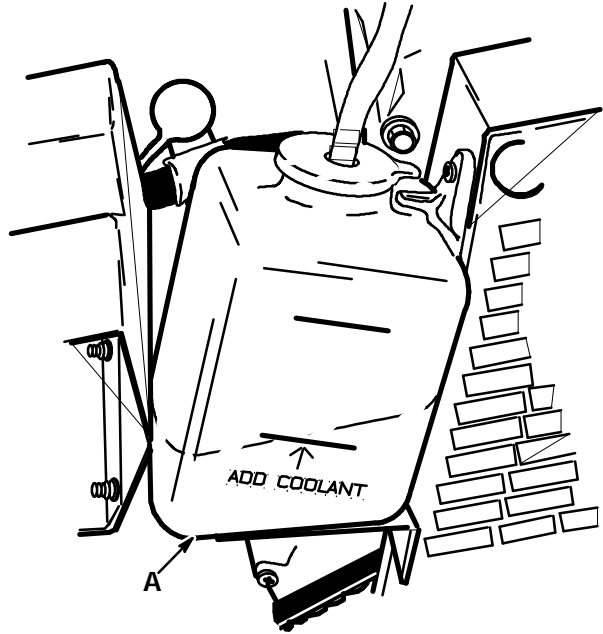

03508

COOLANT TANK

- A. Tank

Use soft, clean water mixed with permanent-type, ethylene glycol antifreeze in a one-to-one ratio to fill the cooling system. Deposits of sludge, scale, and rust prevent normal heat transfer. Flush the radiator and the cooling system after every 200 hours of operation with a dependable cleaning compound. Follow the mixing procedure recommended by the compound manufacturer. This is important because of the difference in concentration and composition of the cleaning compounds. After cleaning, flush the system with clean water.

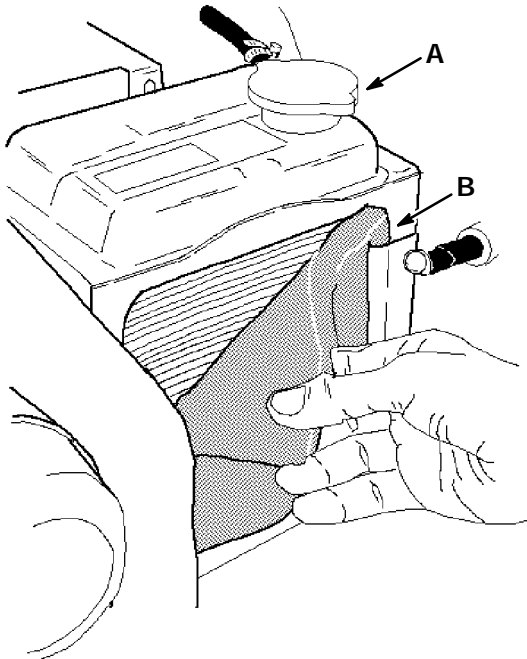

RADIATOR

03504

- A. Radiator**
- B. Pre-Screen**

Whenever a cooling system is badly rust-clogged, as indicated by overflow loss or abnormally high operating temperatures, corrective cleaning by reverse flow flushing will most effectively remove the heavy deposits of sludge, rust, and scale. The reverse flow flushing should be performed immediately after draining the cleaning solution. Flush the radiator first, then the engine, to allow the engine to cool as much as possible.

Engine overheating may also be caused by dirty radiator fins or pre-screen. The exterior fins of the radiator can be cleaned with an air or water hose. Clean or replace the radiator pre-screen after every 75 hours of operation.

FOR SAFETY: When Servicing Machine, Wear Eye And Ear Protection When Using Pressurized Air Or Water.

A pressure cap is used on each radiator to prevent overflow loss of water during normal operation. A spring-loaded valve in the cap closes the outlet to the overflow pipe of the radiator and thus seals the system.

Pressure developing within the system raises the boiling point of the coolant and allows higher temperatures without overflow loss from boiling. One pressure valve opens at 13 psi (90 kPa), allowing steam and water to pass out the overflow pipe into the coolant tank. The other pressure valve opens at 17 psi (115 kPa).

FOR SAFETY: When Servicing Machine, Avoid Contact With Hot Engine Coolant.

ATTENTION! Never pour cold water or cold antifreeze into the radiator of an overheated engine. Allow the engine to cool to avoid cracking the cylinder head or block. Keep the engine running while adding water.

AIR INTAKE SYSTEM

The importance of maintaining an air filter cannot be overemphasized. Dirt ingested through improperly installed, improperly serviced, or inadequate air filter elements wears out more engines than long hours of operation. Even a small amount of dirt will wear out a set of piston rings in just a few hours. Operating with a clogged air filter element also causes the fuel mixture to be richer, which can lead to formation of harmful sludge deposits in the engine. Always cover the air intake when the air filter is removed for servicing. Do not neglect servicing the air filter. Use only approved replacement parts. Keep all other air intake components such as hoses and clamps secure and in good condition to prevent entrance of unfiltered air.

Over maintenance can cause more damage than good. Removing the air filter element more often than is needed allows contaminants to enter the engine unnecessarily. Clean or replace the air filter element only when it is scheduled.

AIR FILTER

The engine air filter housing includes a dust cap and a dry cartridge-type air filter element. The dust cap must be emptied of dirt daily. The air filter element must be cleaned and inspected or replaced after every 100 hours of operation. The filter element must be replaced if it is damaged or has been cleaned three times.

TO REPLACE AIR FILTER ELEMENT

1. Stop the engine and set the machine parking brake.

FOR SAFETY: Before Leaving Or Servicing Machine; Stop On Level Surface, Set Parking Brake, Turn Off Machine And Remove Key.

2. Open the seat support.
3. Unlatch and remove the dust cap.
4. Empty the dust cap.
5. Remove the filter wing nut.
6. Gently pull the filter element out of the filter housing.

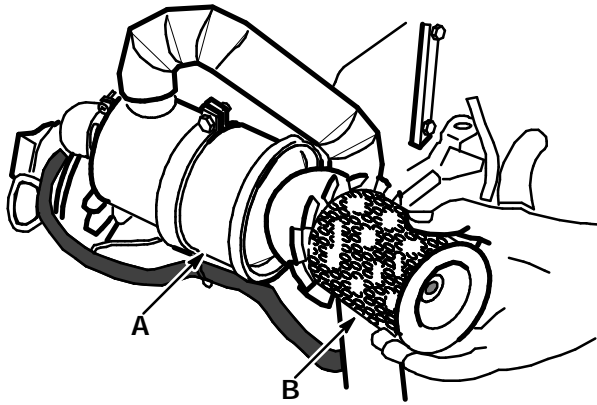

REMOVING AIR FILTER ELEMENT

03493

- A. Filter Housing
- B. Filter Element

7. Clean the interior of the air cleaner housing with a damp cloth. Clean the element housing sealing surfaces.
8. Using an air hose, direct dry, clean air maximum 30 psi (205 kPa) up and down pleats on the inside of the filter. Do not rap, tap, or pound dust out of the element.

FOR SAFETY: When Servicing Machine, Wear Eye And Ear Protection When Using Pressurized Air Or Water.

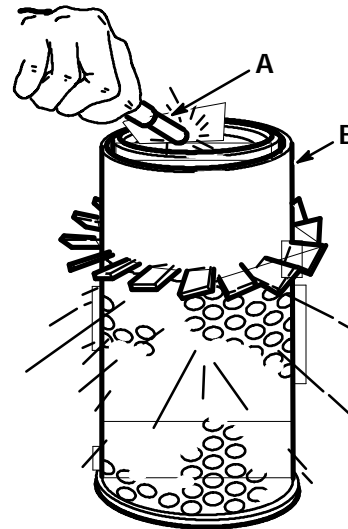

CLEANING AIR FILTER ELEMENT

00051

- A. Air Hose
- B. Filter Element

9. After cleaning the air filter element, inspect it for damage by placing a bright light inside. The slightest rupture requires replacement of the filter. Clean and inspect the ends of the element. They should be unbroken and flexible. Remember, the element must be replaced after it has been cleaned three times.

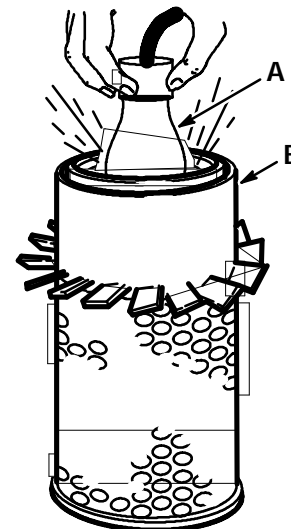

INSPECTING AIR FILTER ELEMENT

03500

- A. Bright Light
- B. Filter Element

10. Install the new or cleaned filter element so the fins on the element are at the intake end of the air cleaner. Use care so the fins are not damaged. Tighten the wing nut attaching the element.
11. Install the dust cap with the tab down. Secure the cap with the latches. Check all intake hose connections for leaks or abrasion.

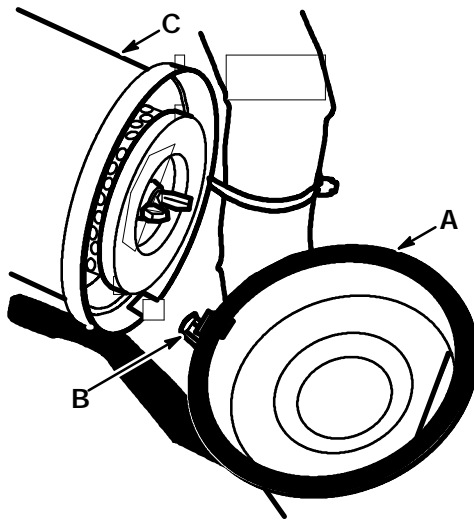

DUST CAP

03484

- A. Dust Cap
- B. Tab
- C. Housing

12. Close the seat support.

FUEL SYSTEM

FUEL SYSTEM

The diesel fuel system is made up of five basic components which are: fuel tank, fuel water trap filter, fuel pump, injection pump, and injectors.

Fuel flows from the fuel tank through the fuel water trap filter. The water trap filter separates water and impurities from the fuel. From the fuel water trap filter, fuel is drawn through the electric fuel pump and pumped to the injection pump. The injection pump pressurizes and sends fuel to the injectors. The injectors atomize and inject proper amounts of fuel into the combustion chamber at the proper times. Excess fuel is returned to the fuel tank through an overflow pipe.

FUEL WATER TRAP FILTER

The fuel water trap filter separates water and impurities from the fuel. It is located next to the fuel tank. The bottom portion of the unit is the water trap. The middle portion is the filter element.

Drain the water trap of water daily. To drain the water trap, loosen the drain knob on the bottom of the unit. First water, then diesel fuel will drain. Tighten the drain knob when diesel fuel appears.

Replace the fuel filter element and clean the water trap after every 400 hours of operation.

TO REPLACE FUEL FILTER ELEMENT

1. Stop the engine and set the machine parking brake.

FOR SAFETY: Before Leaving Or Servicing Machine; Stop On Level Surface, Set Parking Brake, Turn Off Machine And Remove Key.

2. Open the seat support.
3. Close the fuel drain cock.
4. Loosen the water trap vent plug and open the drain valve to drain diesel fuel.

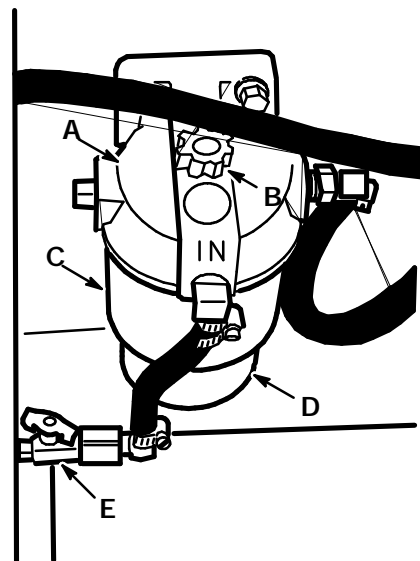

FUEL WATER TRAP FILTER

03494

- A. Filter Head
- B. Vent Plug
- C. Filter Element
- D. Water Trap Bowl
- E. Fuel Drain Cock

MAINTENANCE

5. Remove the filter element and the water trap from the filter head.
6. Remove the water trap bowl from the filter element.
7. Clean the water trap bowl.
8. Lubricate the o-ring and spin the water trap bowl onto the new filter element.
9. Lubricate the o-ring and spin the filter element and water trap onto the filter head.
10. Open the fuel drain cock.
11. Bleed the fuel lines of air as described in *TO PRIME FUEL SYSTEM*.
12. Close the seat support.

PRIMING FUEL SYSTEM

Priming the fuel system removes pockets of air in the fuel lines and fuel components. Air in the fuel system will prevent smooth engine operation.

Prime the fuel system after running out of fuel, changing fuel filter elements or repairing a fuel system component.

TO PRIME FUEL SYSTEM

1. Stop the engine and set the machine parking brake.

FOR SAFETY: Before Leaving Or Servicing Machine; Stop On Level Surface, Set Parking Brake, Turn Off Machine And Remove Key.

2. Fill the fuel tank.
3. Open the seat support.
4. Open the air vent on top of the fuel injection pump.

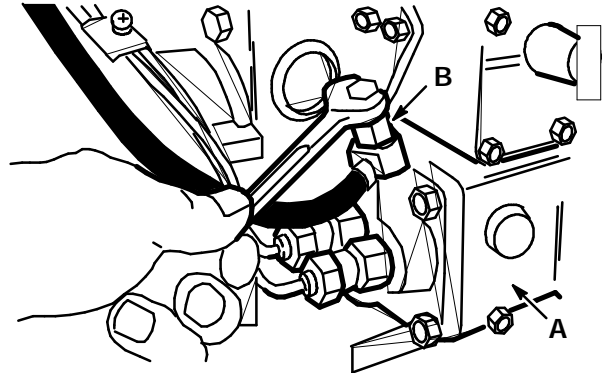

03482

FUEL INJECTION PUMP

- A. Injection Pump**
- B. Air Vent**

5. Turn the ignition switch to the "ON" position (this operates the electric fuel pump) until a steady stream of fuel flows from the vent.
6. Close the air vent.
7. Close the seat support.

DIESEL FUEL TROUBLESHOOTING

Problem	Cause	Remedy
Engine will not start	Out of fuel	Fill fuel tank
	Filter plugged	Clean filter
	Air in fuel	Bleed fuel lines
	Water in fuel	Drain water trap
	Fuel too thick	Change fuel grade
	Battery discharged	Charge or replace battery
	Clogged fuel nozzle	Clean or replace nozzle
	Valve clearance wrong	Adjust valves
	Leaking valves	Grind valves
	Timing wrong	Adjust timing
	Low compression	Repair engine
Engine runs unevenly or lacks power	Dirty air filter	Clean or replace filter
	Plugged fuel filter	Clean filter
	Water in fuel	Drain water trap
	Fuel too thick	Change fuel grade
	Clogged fuel nozzle	Clean or replace nozzle
	Low compression	Repair engine
	Engine overheating	Check radiator Check lubricating system
	Timing wrong	Check timing
	Valve clearance wrong	Adjust valves
	Fuel pressure wrong	Adjust pressure
	Injection pump worn	Repair or replace pump
	Engine stops suddenly	Fuel leak
Out of fuel		Fill fuel tank
Fuel nozzle bad		Replace nozzle
Engine overheating		Check radiator Check lubricating system
Timing wrong		Check timing
Exhaust color bad	Fuel governor failure	Repair or replace
	Bad fuel	Change fuel grade
	Fuel nozzle bad	Replace nozzle
	Timing wrong	Check timing
	Low compression	Repair engine
	Valve clearance wrong	Adjust valves
	Injection pump worn	Repair or replace pump

CYLINDER HEAD

CYLINDER HEAD

The cylinder head must be properly torqued after servicing to ensure proper operation. A three-stage torque procedure should be used. Snug down the cylinder head bolts and nuts in the proper sequence; first to one-third, then two-thirds, and then to the full torque specification of 42 to 45 ft lb (55 to 60 Nm). Retighten the bolts and nuts after operating the engine for 30 minutes.

NOTE: Power wrench torque limit must be held at least 10 ft lb (15 Nm) below torque specification. Hand tighten to specification.

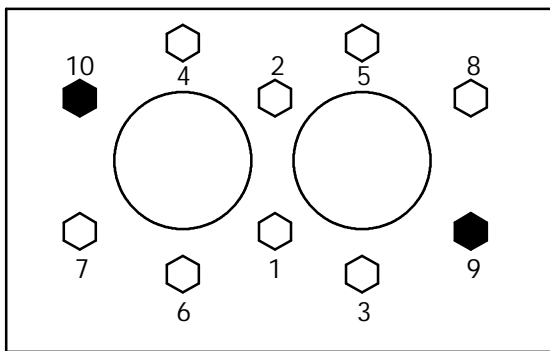

03483

CYLINDER HEAD BOLT TIGHTENING SEQUENCE

VALVE CLEARANCE

The valve clearance must be properly adjusted after servicing or retorquing the cylinder head bolts to ensure proper operation. Measure valve clearance with a feeler gauge after aligning each cylinder on the compression top dead center stroke.

Adjust them with the engine cool to 0.0057 to 0.0073 in (0.14 to 0.18 mm).

DECOMPRESSION LEVER

The decompression lever was available on earlier style engines. The lever allows the release of some compression pressure from the cylinders. This is useful when the battery is weak, when the engine has not been run for a long period of time, and when the engine is in a cold ambient temperature.

To engage, push the lever down while cranking the engine. Then release the lever to engage the injection system. Do not touch the lever when the engine is operating or the engine valve system may be damaged. Do not press the lever when the engine is not turning over or it may be difficult or impossible to start.

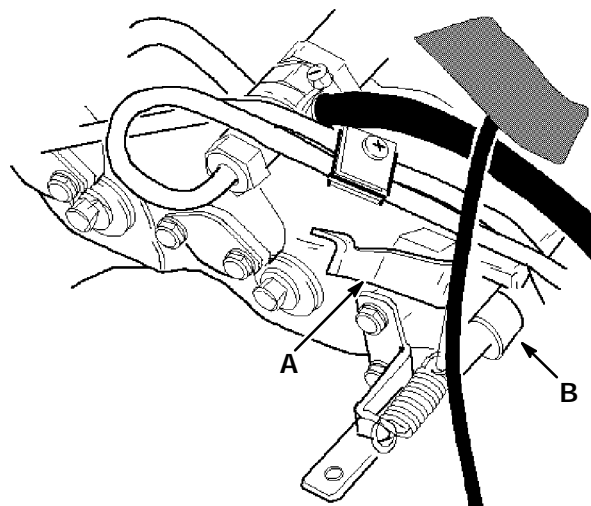

03492

DECOMPRESSION LEVER

- A. Lever
- B. Injection Pump

ELECTRICAL SYSTEM

BATTERY

The battery used in this machine is rated at 12 V, 330 ccA. It is located in the front left of the machine behind the hopper. When removing battery cables, remove the negative (-) cable before the positive (+) cable.

Clean the top surface and the terminals of the battery periodically. Use a strong solution of baking soda and water. Brush the solution sparingly over the battery top, terminals, and cable clamps. Do not allow any baking soda solution to enter the battery. Use a wire brush to clean the terminal posts and the cable connectors. After cleaning, apply a coating of clear petroleum jelly to the terminals and the cable connectors. Keep the top of the battery clean and dry.

Keep all metallic objects off the top of the battery, as they may cause a short circuit. Replace worn or damaged wires.

The electrolyte level in regular nonsealed batteries can be checked. It must always be above the battery plates. Add distilled water to maintain solution at the correct level above the plates, but do not overfill. Never add acid to batteries, only water. Keep vent plugs firmly in place at all times, except when adding water or taking hydrometer readings.

FOR SAFETY: When Servicing Machine, Avoid Contact With Battery Acid.

If when checking battery specific gravity, one or more battery cells tests lower than the other battery cells, (0.050 or more) the cell is damaged, shorted, or is about to fail.

NOTE: Do not take readings immediately after adding water--if the water and acid are not thoroughly mixed, the readings may not be accurate. Check the hydrometer readings against this chart:

SPECIFIC GRAVITY AT 80° F (27° C)	BATTERY CONDITION
1.265	100% charged
1.225	75% charged
1.190	50% charged
1.155	25% charged
1.120	Discharged

NOTE: If the readings are taken when the battery electrolyte is any temperature other than 80° F (27° C), the reading must be temperature corrected.

To determine the corrected specific gravity reading when the temperature of the battery electrolyte is other than 80° F (27° C):

Add to the specific gravity reading 0.004 (4 points) for each 10° F (6° C) above 80° F (27° C).

Subtract from the specific gravity reading 0.004 (4 points) for each 10° F (6° C) below 80° F (27° C).

MAINTENANCE

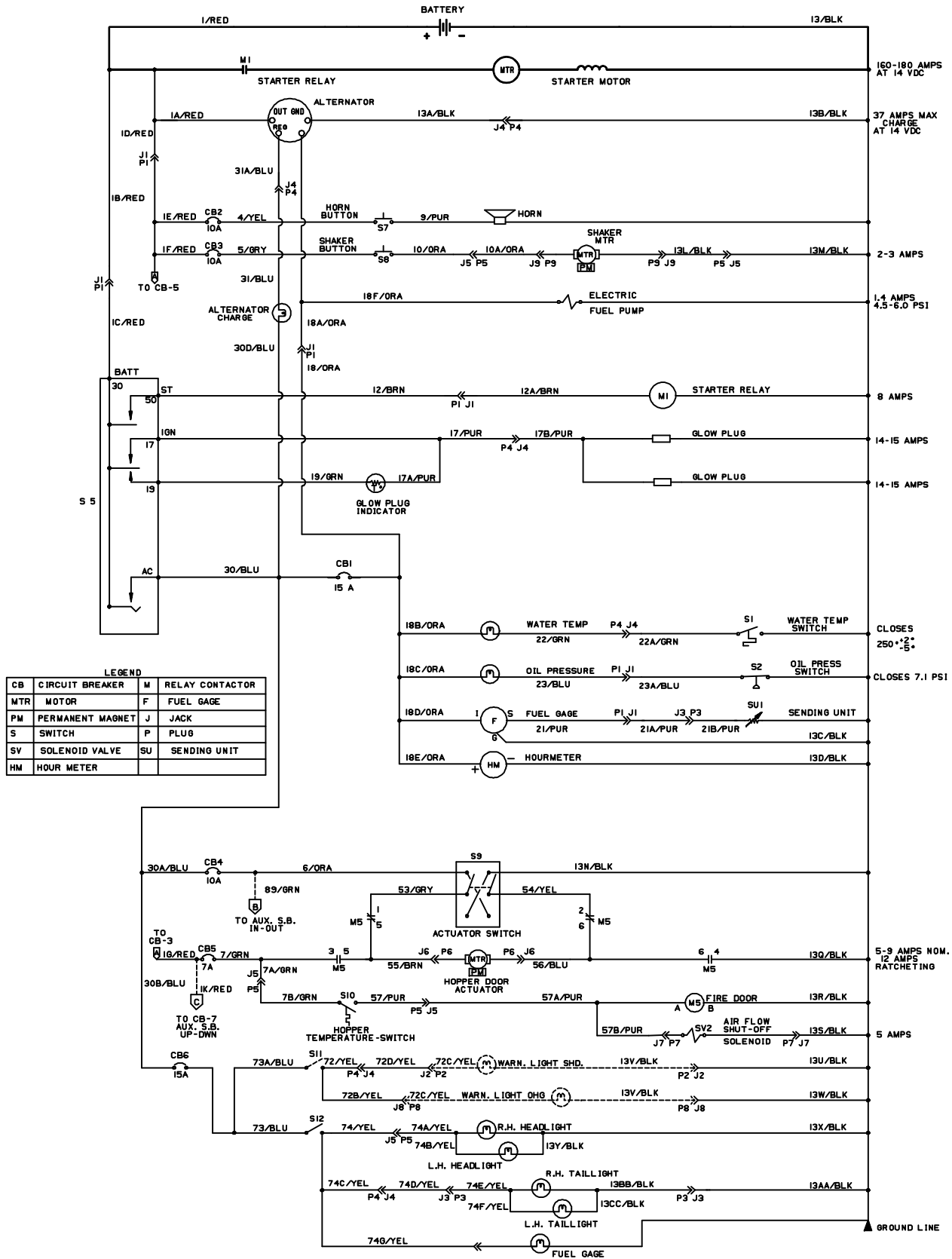

LEGEND

CB	CIRCUIT BREAKER	M	RELAY CONTACTOR
MTR	MOTOR	F	FUEL GAGE
PM	PERMANENT MAGNET	J	JACK
S	SWITCH	P	PLUG
SV	SOLENOID VALVE	SU	SENDING UNIT
HM	HOUR METER		

ELECTRICAL SCHEMATIC

03490

GROUND
LINE

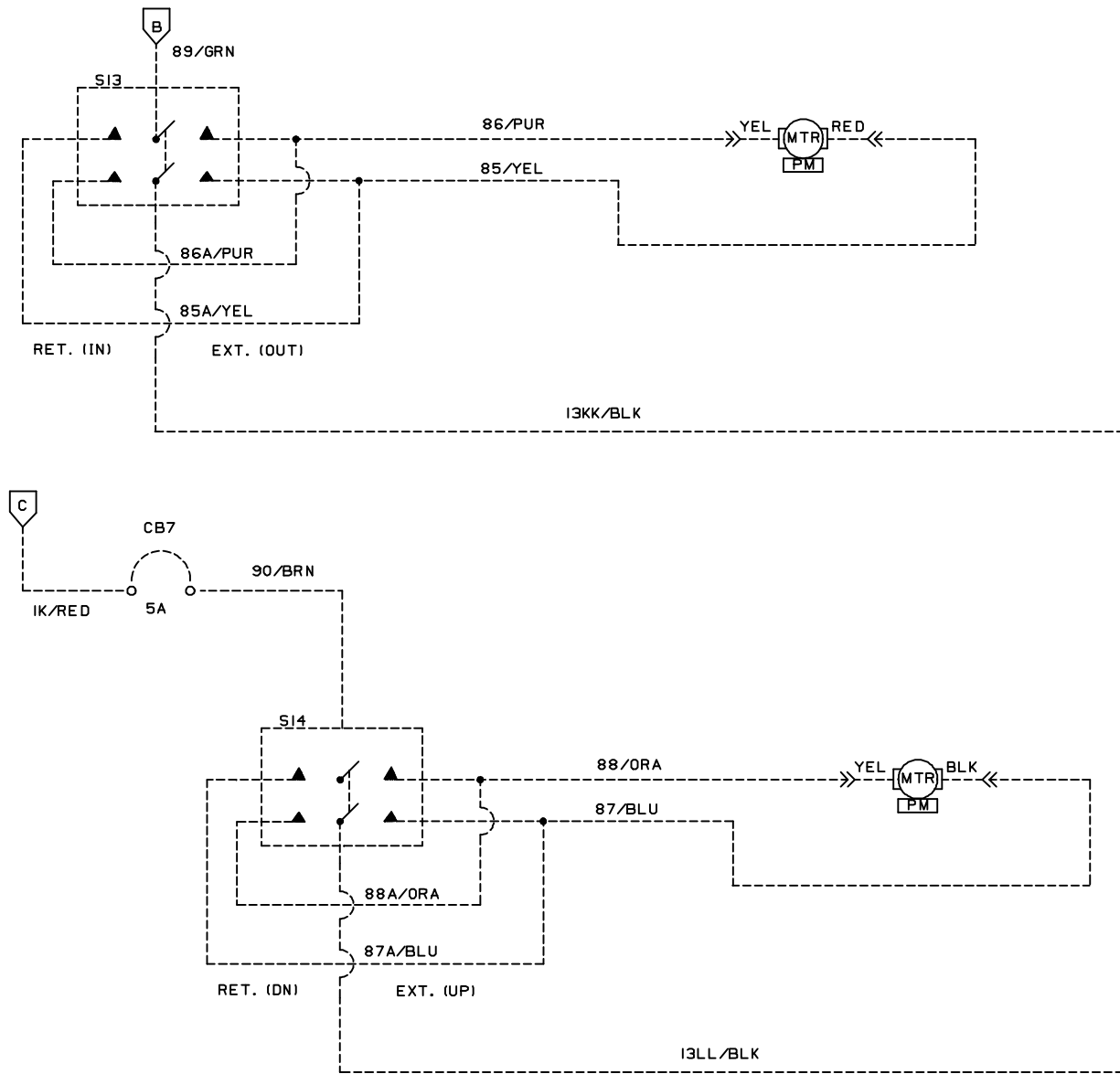

ELECTRICAL SCHEMATIC, AUXILIARY SIDE BRUSH

03490

BELTS AND CHAINS

HYDRAULIC PUMP BELT

The hydraulic pump belt transfers power from the engine sheave to the hydraulic pump. Check belt condition and tension after every 200 hours of operation. The belt is properly tensioned when it deflects 0.26 in (7 mm) from a force of 7 lb (3 kg) applied at belt midpoint.

TO REPLACE AND ADJUST HYDRAULIC PUMP BELT

1. Stop the engine and set the machine parking brake.

FOR SAFETY: Before Leaving Or Servicing Machine; Stop On Level Surface, Set Parking Brake, Turn Off Machine And Remove Key.

2. Open the seat support.
3. Remove the vacuum fan and engine belt guards.
4. Loosen the pump plate mounting and adjustment bolts.

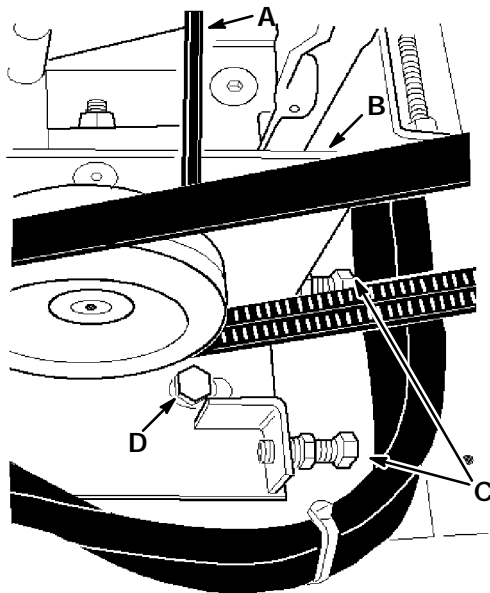

HYDRAULIC PUMP

03498

- A. Hydraulic Pump
- B. Pump Plate
- C. Adjustment Bolts
- D. Mounting Bolts

5. Slide the pump assembly backward to remove the belt. Position the new pump belt on the sheaves.
6. Push the pump forward keeping the sheaves aligned and snug the mounting bolts.
7. Check belt tension. If it meets specification, tighten the bolts. If not, repeat the steps.

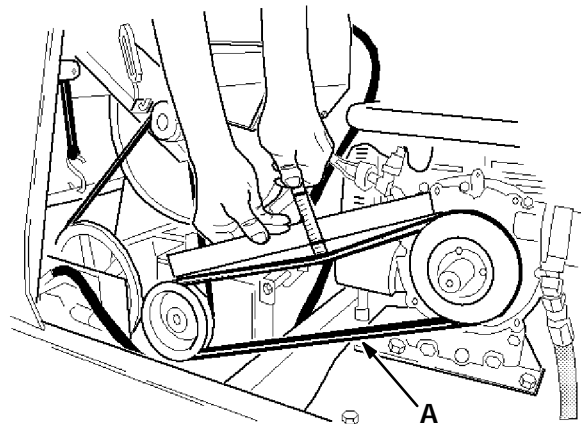

04233

CHECKING BELT TENSION

A. Hydraulic Pump Belt

8. Replace belt guards.
9. Lower the seat support.

VACUUM FAN BELT

The vacuum fan belt transfers power from the pump sheave to the vacuum fan and the accessories pump. Check the belt condition and tension after every 200 hours of operation. The belt is properly tensioned when the belt deflects 0.25 in (6 mm) from a force of 6 lb (3 kg) applied at belt midpoint.

TO REPLACE AND ADJUST VACUUM FAN BELT

1. Stop the engine and set the machine parking brake.

FOR SAFETY: Before Leaving Or Servicing Machine; Stop On Level Surface, Set Parking Brake, Turn Off Machine And Remove Key.

2. Open the seat support.

- Remove the vacuum fan belt guard.

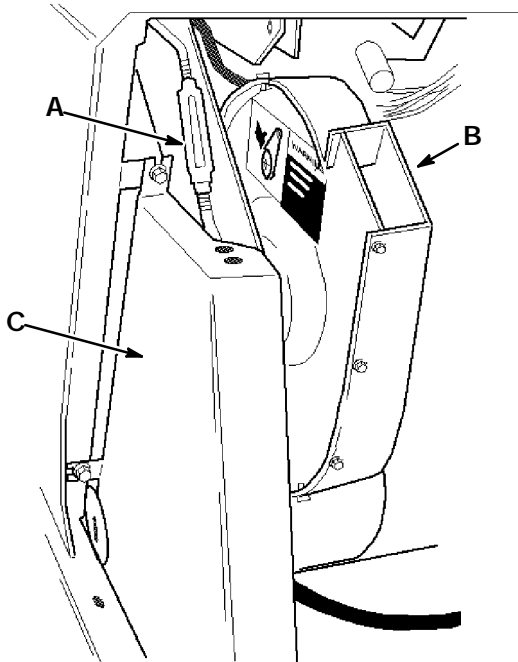

VACUUM FAN BELT GUARD

04322

- A. Turnbuckle
- B. Vacuum Fan
- C. Belt Guard

- Loosen the pump plate mounting and adjustment bolts.

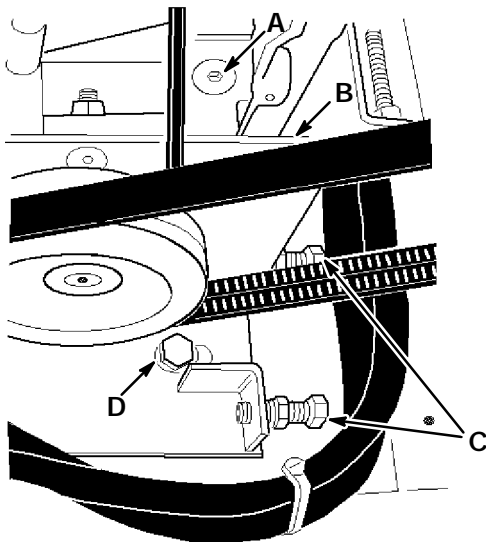

HYDRAULIC PUMP

03498

- A. Hydraulic Pump
- B. Pump Plate
- C. Adjustment Bolts
- D. Mounting Bolts

- Slide the pump assembly backward to remove the belts.
- Replace the existing vacuum fan belt with a new belt.

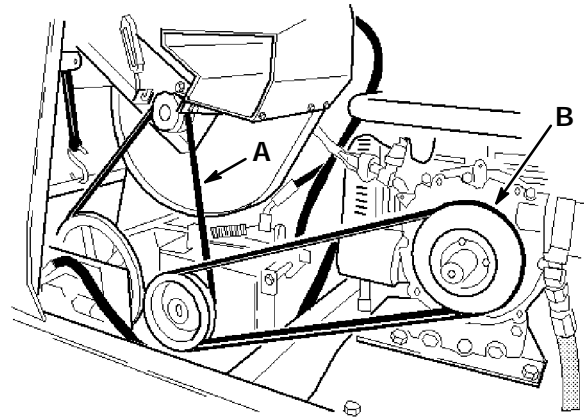

BELTS

03499

- A. Vacuum Fan Belt
- B. Pump Belt

- Position the pump belt on the sheaves.
- Push the pump forward keeping the sheaves aligned and snug the mounting bolts.
- Tighten the pump belt as described in *TO REPLACE AND ADJUST HYDRAULIC PUMP BELT*.
- Turn the turnbuckle to tighten the vacuum fan belt to specification.

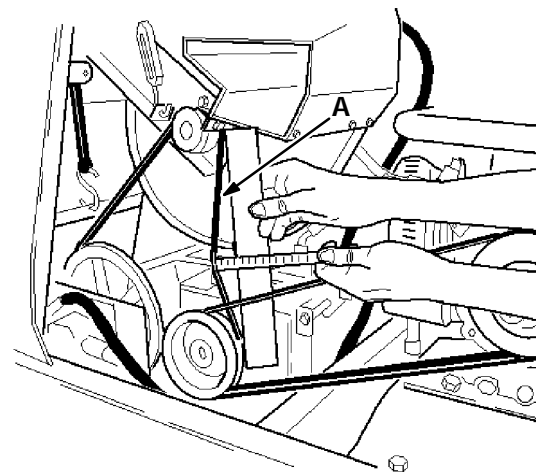

CHECKING BELT TENSION

04234

- A. Vacuum Fan Belt

MAINTENANCE

11. Replace the belt guard.
12. Lower the seat support.

MAIN BRUSH BELT

The main brush belt transfers power from the accessories pump to the main brush. The belt is tensioned by a belt idler spring. A stop bolt is used to remove tension from the belt when the main brush is raised.

TO REPLACE MAIN BRUSH BELT

1. Stop the engine and set the machine parking brake.

FOR SAFETY: Before Leaving Or Servicing Machine; Stop On Level Surface, Set Parking Brake, Turn Off Machine And Remove Key.

2. Raise the main brush.
3. Open the seat support.
4. Remove the vacuum fan belt guard.
5. Remove the left side access door.
6. Hold the idler spring arm back and remove the belt.

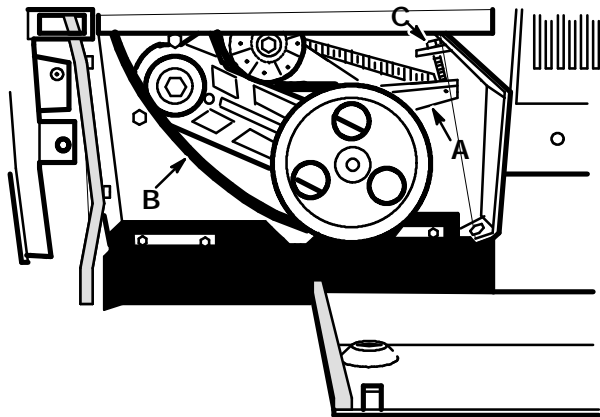

03377

MAIN BRUSH BELT

- A. Idler Spring Arm
- B. Main Brush Belt
- C. Stop Bolt

7. Position the new belt on the belt sheaves.
8. Replace the vacuum fan belt guard.
9. Lower the seat support.
10. Start the machine and lower the main brush. Then raise the brush. The brush should stop turning within seconds of being raised. If the belt is too tight, the brush will continue to turn. If the belt is too loose, it may jump off the idler or driven sheave. Turn the belt stop bolt to adjust belt tension.

11. Replace the left side access door.

FAN BELT

The fan belt is driven by the crankshaft sheave and drives the alternator and the radiator fan. Check the belt condition and tension after every 200 hours of operation. The belt is properly tensioned when the belt deflects 0.28 in (7 mm) from a force of 22 lb (10 kg) applied at belt midpoint.

TO REPLACE AND ADJUST FAN BELT

1. Stop the engine and set the machine parking brake.

FOR SAFETY: Before Leaving Or Servicing Machine; Stop On Level Surface, Set Parking Brake, Turn Off Machine And Remove Key.

2. Open the seat support.

- Remove the vacuum fan and engine belt guards.

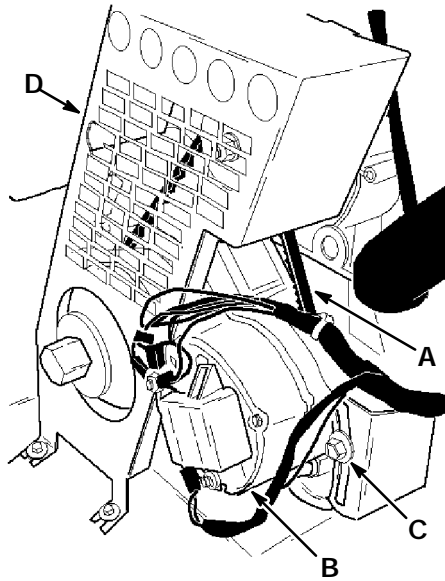

FAN BELT

03503

- A. Fan Belt
- B. Alternator
- C. Mounting Bolt
- D. Engine Belt Guard

- Loosen the pump plate mounting and adjustment bolts.

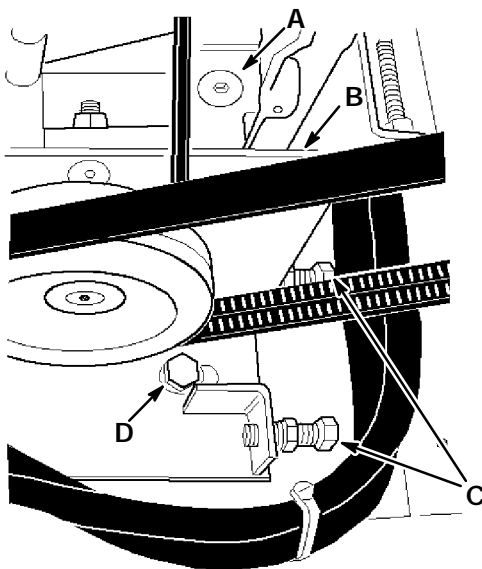

HYDRAULIC PUMP

03498

- A. Hydraulic Pump
- B. Pump Plate
- C. Adjustment Bolts
- D. Mounting Bolts

- Slide the pump assembly backward to remove the belt.
- Loosen the alternator mounting bolts.
- Replace the fan belt.
- Tighten the fan belt to specification.

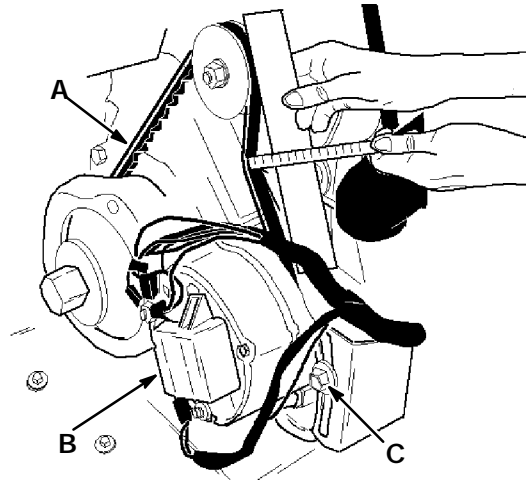

CHECKING BELT TENSION

04235

- A. Engine Fan Belt
- B. Alternator
- C. Mounting Bolt

- Position the hydraulic pump belts back on the sheaves.
- Push the pump forward keeping the sheaves aligned and snug the mounting bolts.
- Tighten the pump belt as described in *TO REPLACE AND ADJUST HYDRAULIC PUMP BELT*.
- Replace the belt guards.
- Lower the seat support.

TAPER LOCK BUSHINGS

Taper lock bushings are used to secure the sheaves on the engine and propelling pump shafts.

TO REMOVE TAPER LOCK BUSHING

1. Remove all set screws.
2. Insert a set screw into the threaded hole of the bushing.

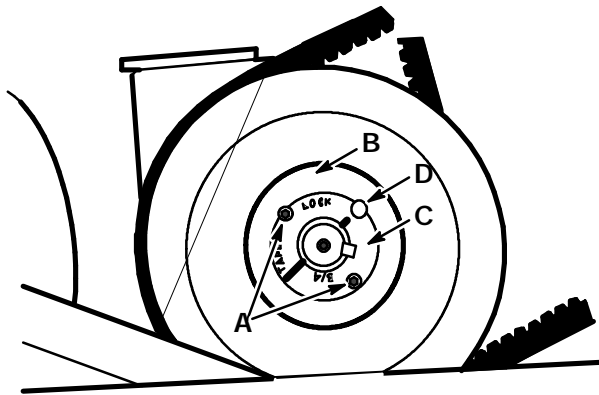

TAPER LOCK BUSHING

03506

- A. Set Screw
- B. Hub
- C. Bushing
- D. Threaded Hole

3. Tighten the set screw to loosen bushing from shaft.

TO INSTALL TAPER LOCK BUSHING

1. Clean shaft, bore and outside of bushing and hub bore of all oil, lacquer, and dirt.
2. Insert bushing into hub; be aware of sheave alignment. Match hole pattern, not threaded holes. Each hole will be threaded on one side only.
3. Oil set screws. Thread them into the half threaded holes.
4. Alternately tighten the set screws to 175 in lb (20 Nm).

5. Using a block, sleeve, or drift, hammer the end of the bushing. Do not hammer bushing directly.
6. Repeat steps 4 and 5 until torque wrench reading is the same after hammering as before.
7. Fill all open holes with grease.

STATIC DRAG CHAIN

The static drag chain prevents the buildup of static electricity in the machine. The chain is attached to the rear skirt retaining strip.

Make sure that the chain is making contact with the floor at all times.

DEBRIS HOPPER AND DUST FILTER

DEBRIS HOPPER

The debris hopper collects debris swept by the machine and should be dumped after every work shift. The hopper floor clearance should be checked and adjusted periodically.

TO CHECK AND ADJUST HOPPER FLOOR CLEARANCE

1. Empty the hopper and park the machine on a smooth, level surface.
2. Lower the hopper.
3. Stop the engine and set the machine parking brake.

FOR SAFETY: Before Leaving Or Servicing Machine; Stop On Level Surface, Set Parking Brake, Turn Off Machine And Remove Key.

4. Check the hopper bumper to machine frame match. They should line up within 0.12 in (5 mm). Adjust by repositioning the stop bolts on the frame above the front wheels.

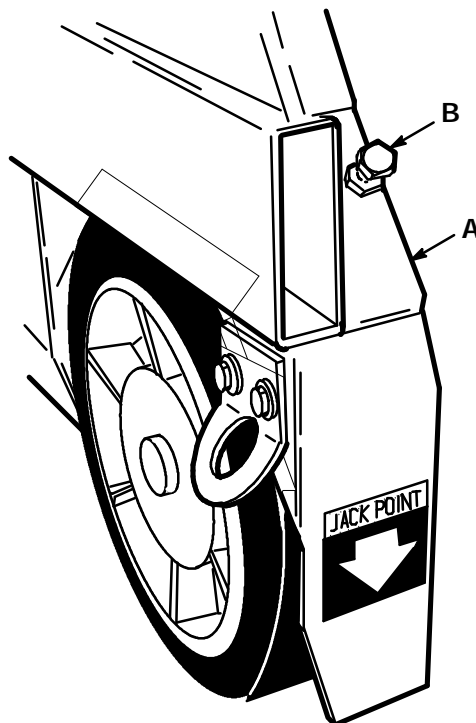

BUMPER STOP BOLT

03372

- A. Frame
- B. Stop Bolt

5. Check the distance between the floor and the bottom metal edge of the hopper. The floor clearance should be 1 in (25 mm) across the width of the machine. To adjust the hopper floor clearance, unlatch and remove the filter cover and adjust the hopper stop bolt.

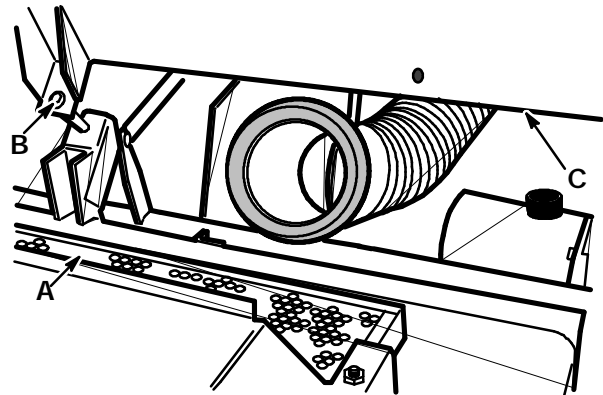

HOPPER STOP BOLT

03387

- A. Hopper
- B. Stop Bolt
- C. Lintel

6. Replace the filter cover and check the hopper cover seal. It should be slightly compressed.

THERMO SENTRY™

The Thermo Sentry™ stops the machine vacuum and closes the hopper door in case of a fire in the hopper. Check to make sure the Thermo Sentry™ is operating properly after every 100 hours of operation.

TO CHECK THE THERMO SENTRY™

1. Stop the engine and set the machine parking brake.

FOR SAFETY: Before Leaving Or Servicing Machine; Stop On Level Surface, Set Parking Brake, Turn Off Machine And Remove Key.

2. Unlatch the filter cover latches and remove the filter cover.
3. Place the vacuum lever in the "Normal Sweeping" position.

4. Apply heat to the bottom of the Thermo Sentry™ with a match or lighter. The vacuum lever should move to the “Wet Sweeping” position, the hopper door should close, and their circuit breakers should trip. If they do not, the system is malfunctioning.

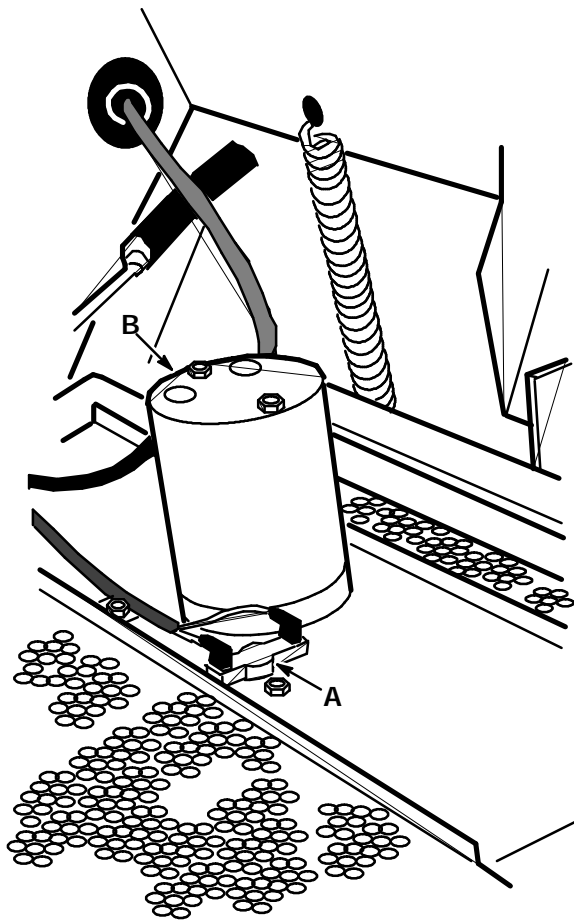

- A. Thermo Sentry™**
B. Shaker Motor

5. Replace the filter cover and check the hopper cover seal. It should be slightly compressed.
6. After the Thermo Sentry™ has cooled, reset the circuit breakers behind the control panel.

HOPPER DUST FILTER

The hopper dust filter filters the air which is drawn up from the main brush compartment by the vacuum fan. It is located inside the dust filter compartment. Shake the excess dust from the filter daily. Inspect and clean or replace the dust filter after every 100 hours of operation.

To clean the dust filter use one of the following methods:

- **TAPPING** - Tap the filter gently on a flat surface with the dirty side down. Do not damage the edges of the filter element or the filter will not seat properly in the filter frame.
- **AIR** - Blow compressed air, 35 psi (240 kPa) maximum, through the dust filter opposite the direction of the arrows. This may be done with the filter in the machine. Always wear eye protection when using compressed air.

FOR SAFETY: When Servicing Machine, Wear Eye And Ear Protection When Using Pressurized Air Or Water.

- **WATER** - Soak the dust filter in a water and mild detergent solution. Rinse the dust filter until it is clean. The maximum water pressure allowable is 40 psi (275 kPa). Air dry the wet filter; do not use compressed air.

NOTE: Be sure the dust filter is dry before reinstalling it in the machine.

TO REMOVE AND REPLACE HOPPER DUST FILTER

1. Stop the engine and set the machine parking brake.

FOR SAFETY: Before Leaving Or Servicing Machine; Stop On Level Surface, Set Parking Brake, Turn Off Machine And Remove Key.

2. Unlatch the two filter cover latches and remove the filter cover.
3. Remove the two assembly bolts on each side of the filter and slide the assembly back. Remove the dust filter.

6. Secure the filter with the shaker motor assembly.
7. Check the two filter hold-down screws. They should clear the filter by 0.03 in (1 mm).
8. Secure the filter cover on the filter frame with the two latches.
9. Check the hopper cover seal. It should be slightly compressed.

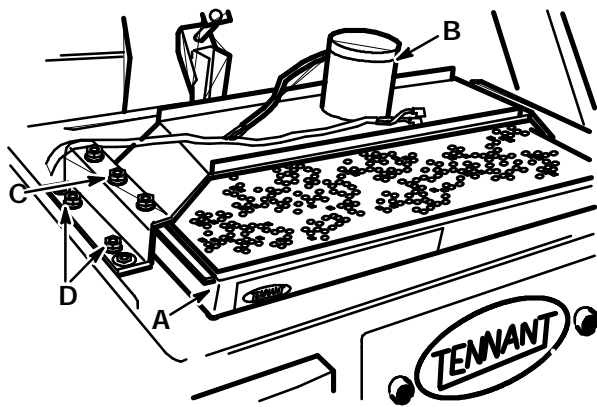

DUST FILTER

03389

- A. Dust Filter
- B. Shaker Motor Assembly
- C. Hold-Down Screws
- D. Assembly Bolts

4. Inspect and clean or replace the dust filter.
5. Position the dust filter in the filter frame with the arrows on the label pointing up.

BRUSHES

MAIN BRUSH

The main brush is tubular and spans the width of the machine, sweeping debris into the debris hopper. The brush should be inspected daily for wear or damage. Remove any string or wire found tangled on the main brush, main brush drive hub, or main brush idler hub.

Rotate the main brush end-for-end after every 50 hours of operation for maximum brush life and best sweeping performance. Check the main brush pattern whenever installing a new brush.

The main brush should be replaced when the remaining bristles measure 1.5 in (40 mm) or less in length.

TO REMOVE MAIN BRUSH

1. Stop engine and set the machine parking brake.

FOR SAFETY: Before Leaving Or Servicing Machine; Stop On Level Surface, Set Parking Brake, Turn Off Machine And Remove Key.

2. Lower the main brush.
3. Remove the right side access door.
4. Remove the brush idler arm retaining bolt from the arm hub.

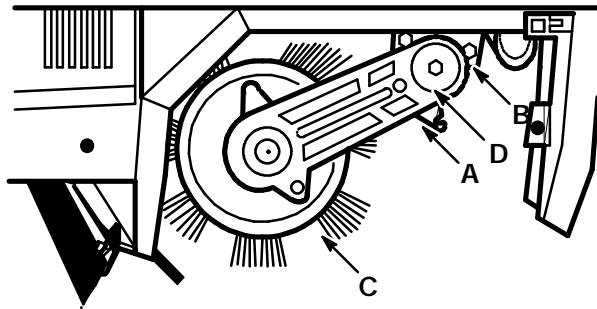

MAIN BRUSH IDLER ARM

03390

- A. Brush Idler Arm**
- B. Arm Retaining Bolt**
- C. Main Brush**
- D. Threaded Hole**

5. Pull the brush idler arm off the arm hub.

NOTE: If the brush idler arm does not come off easily, thread the retaining bolt into the threaded hole on the arm. Tighten the bolt until it is tight against the backing plate. Push on the brush end of the arm and retighten the bolt. Repeat until the arm is loose.

6. Grasp the main brush, pull it off the brush drive plug, and out of the main brush compartment.

TO INSTALL MAIN BRUSH

1. Push the main brush lever into the "UP" position.
2. Slide the main brush into the main brush compartment.
3. Align the main brush drive slots with the drive keys on the main brush drive plug.
4. Slide the main brush onto the drive plug. Make sure the drive slots and keys mate.
5. Align the main brush idler plug slots with the main brush keys. Slide the main brush idler plug into the main brush tube.
6. Slide the brush idler arm onto the arm hub.
7. Thread the brush idler arm retaining bolt through the idler arm and into the arm hub.
8. Tighten the brush idler arm retaining bolt.
9. Replace the right side access door.

TO CHECK AND ADJUST MAIN BRUSH PATTERN

1. Apply chalk, or some other material that will not blow away easily, to a smooth, level floor.
2. With the side brush and main brush raised, position the main brush over the chalked area.
3. While keeping a foot on the brakes to keep the machine from moving, lower the main brush to the floor for 15 to 20 seconds; raise the main brush and drive the machine off the test area.

NOTE: If no chalk or other material is available, allow the brushes to spin on the floor for two minutes.

4. Observe the brush pattern made. The pattern should be of equal width across the length of the pattern.

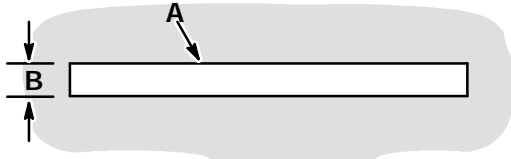

NORMAL MAIN BRUSH PATTERN

00582

- A. Main Brush Pattern
- B. 2 to 2.5 in (51 to 54 mm) for machines serial number 002594 and above

For machines serial number 002594 and above, and machines with the Brush Limiter Kit installed, the brush pattern width should be 2 to 2.5 in (51 to 54 mm). The brush pattern width can be adjusted by loosening and moving the brush limiter nut.

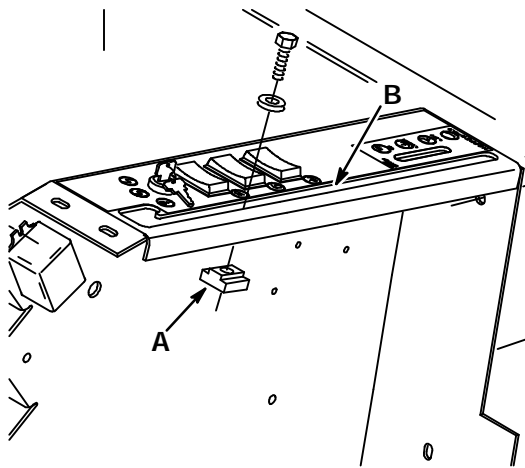

BRUSH LIMITER NUT (For machines serial number 002594 and above)

03487

- A. Brush Limiter Nut
- B. Main Brush Lever Slot

To decrease the width of the brush pattern, move the limiter nut forward and tighten the nut. To increase the brush pattern width, move the limiter nut back and tighten the nut.

If the main brush pattern is tapered, wider on one side by 0.50 in (15 mm) or more than the other side, perform the following leveling procedure:

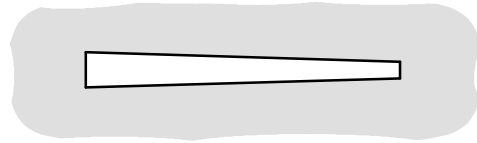

00601

TAPERED MAIN BRUSH PATTERN

- A. Park the machine on a level surface.
- B. Stop the engine and set the machine parking brake.

FOR SAFETY: Before Leaving Or Servicing Machine; Stop On Level Surface, Set Parking Brake, Turn Off Machine And Remove Key.

- C. Lower the main brush.
- D. Remove the right side access door.
- E. Remove the main brush.
- F. Reinstall the idler arm.
- G. Loosen the cross shaft bearing flange bolts.

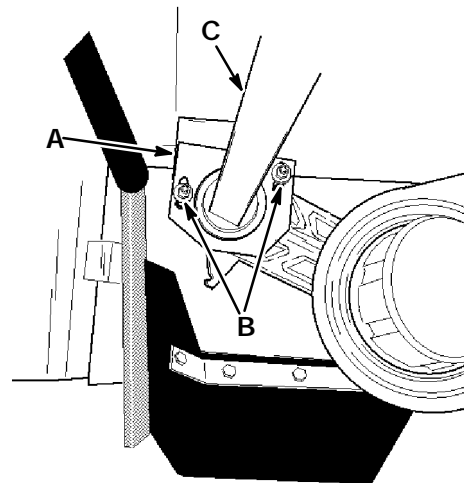

03550

CROSS SHAFT BEARING FLANGE

- A. Flange
- B. Bolts
- C. Cross Shaft

- H. Position the idler plug so it is the same distance from the floor as the drive plug and tighten the bolts.
- I. Reinstall the main brush.
- J. Recheck the main brush pattern.
- K. Replace the right side access door.

SIDE BRUSH

The side brush sweeps debris from curbs or gutters into the path of the main brush. The side brush should be inspected daily for wear or damage. Remove any string or wire found tangled on the side brush or side brush drive hub.

The side brush pattern should be checked periodically. One-third of the side brush bristles should contact the floor when the brush is in motion. The side brush pattern adjustment is made by turning the side brush adjustment knob on the front bumper.

The side brush should be replaced when the remaining brush bristle measures 2.5 in (65 mm) in length.

TO REMOVE SIDE BRUSH

1. Raise the hopper.
2. Engage the hopper support bar.



WARNING: Falling Hopper. Engage Hopper Support Bar. Read Manual.

3. Stop the engine and set the machine parking brake.

FOR SAFETY: Before Leaving Or Servicing Machine; Stop On Level Surface, Set Parking Brake, Turn Off Machine And Remove Key.

4. Raise the side brush.
5. Remove the four side brush retaining bolts from the bottom of the side brush.

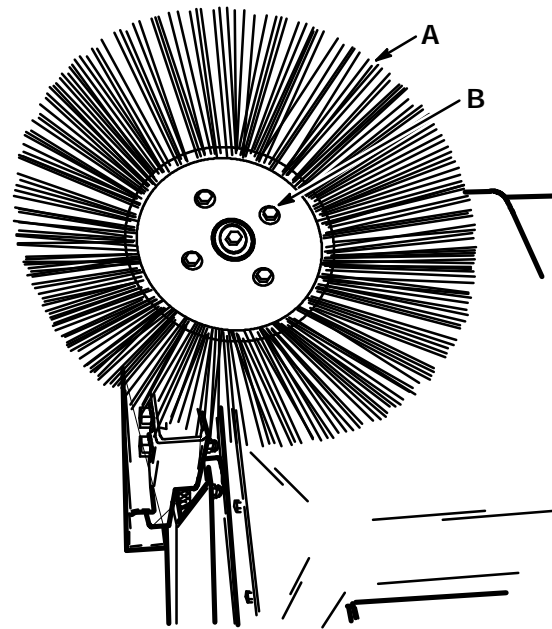

SIDE BRUSH

03392

- A. Side Brush
- B. Retaining Bolts

6. Slide the side brush off the side brush hub.

TO INSTALL SIDE BRUSH

1. Position the side brush on the side brush drive hub.
2. Secure the side brush to the hub with the four bolts removed earlier.
3. Check the side brush pattern. Adjust the pattern with the side brush adjustment knob.

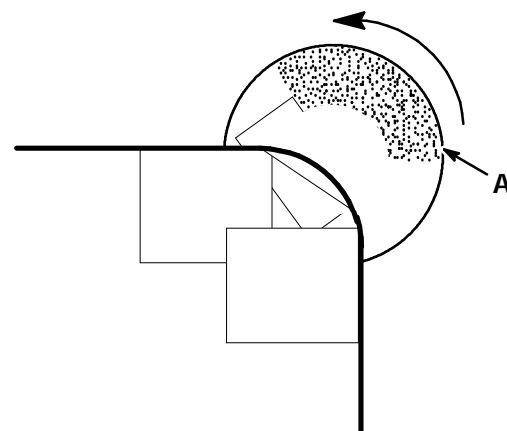

SIDE BRUSH PATTERN

03376

- A. Contact Area

SKIRTS AND SEALS

BRUSH SKIRTS

Brush skirts control main brush dusting. They are located on each of the brush access doors. The skirts should be inspected for wear or damage daily. They should clear the floor by 0 to 0.12 in (0 to 5 mm) at all times.

TO REPLACE AND ADJUST BRUSH SKIRTS

1. Park the machine on a smooth, level floor.
2. Stop the engine and set the machine parking brake.

FOR SAFETY: Before Leaving Or Servicing Machine; Stop On Level Surface, Set Parking Brake, Turn Off Machine And Remove Key.

3. Remove the side access doors.
4. Replace or loosen the skirt and retaining strip bolts. Adjust the skirt height and retighten the retaining strip bolts.

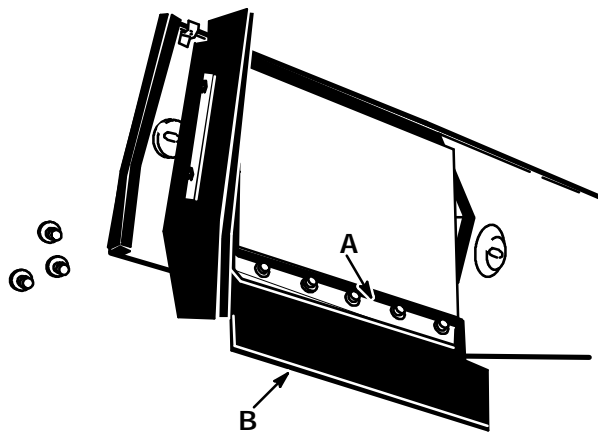

RIGHT SIDE BRUSH SKIRT

03388

- A. Retaining Strip
- B. Brush Skirt

5. Replace the doors.
6. Check the skirt clearance.

REAR SKIRTS

The rear skirts seal the brush compartment. They are located on the bottom rear of the brush compartment. The seals should be inspected for wear or damage daily.

TO REPLACE AND ADJUST REAR SKIRTS

1. Park the machine on a smooth, level surface.
2. Stop the engine and set the machine parking brake.

FOR SAFETY: Before Leaving Or Servicing Machine; Stop On Level Surface, Set Parking Brake, Turn Off Machine And Remove Key.

3. Remove the side access doors.
4. Remove the rear skirt retaining strips and the rear skirts.

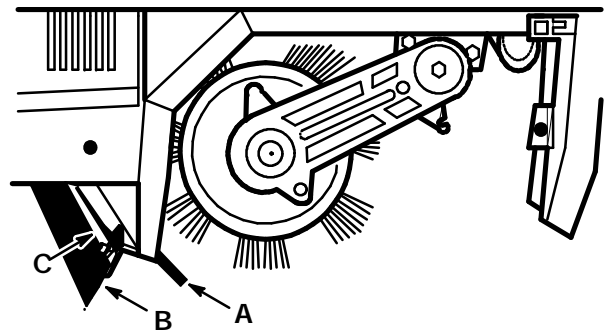

REAR SKIRTS

03390

- A. Brush Skirt
- B. Vertical Rear Skirt
- C. Retaining Strip

5. Loosely install new skirts with the existing retaining strips.
6. Slide the vertical rear skirt up or down so it is 0 to 0.12 in (0 to 5 mm) above the floor.
7. Retighten the retaining strip bolts.

HOPPER LIP SKIRT

The hopper lip skirt floats over debris and helps deflect the debris into the hopper. It is located on the bottom rear of the hopper.

The hopper lip skirt should be inspected for wear or damage daily.

TO REPLACE HOPPER LIP SKIRT

1. Empty the machine debris hopper.
2. Raise the hopper.
3. Engage the hopper support bar.

! WARNING: Falling Hopper. Engage Hopper Support Bar. Read Manual.

4. Stop the machine on a level surface, stop the engine, and set the machine parking brake.

FOR SAFETY: Before Leaving Or Servicing Machine; Stop On Level Surface, Set Parking Brake, Turn Off Machine And Remove Key.

5. Remove the skirt retaining strip and the skirt.

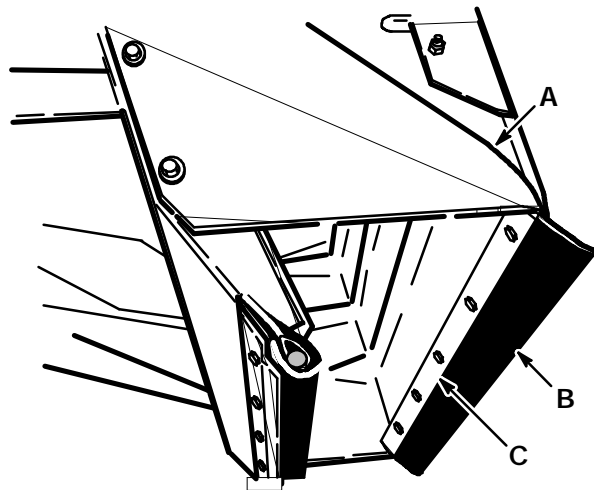

HOPPER LIP SKIRT

03384

- A. Hopper
- B. Lip Skirt
- C. Retaining Strip

6. Position the new skirt on the hopper. Secure it with the retaining strip.
7. Raise the hopper, position the hopper support bar in its storage location, and lower the hopper.

DUST SEALS

Three seals control hopper dusting. They are the top, left and right side hopper seals. They should be inspected for wear or damage after every 100 hours of operation.

TO REPLACE DUST SEALS

1. Empty the debris hopper.
2. Raise the hopper.
3. Engage the hopper support bar.

! WARNING: Falling Hopper. Engage Hopper Support Bar. Read Manual.

4. Stop the engine and set the machine parking brake.

FOR SAFETY: Before Leaving Or Servicing Machine; Stop On Level Surface, Set Parking Brake, Turn Off Machine And Remove Key.

5. Remove the side access doors to gain access to the side seals.

- Remove the retaining strip of the seal to be replaced.

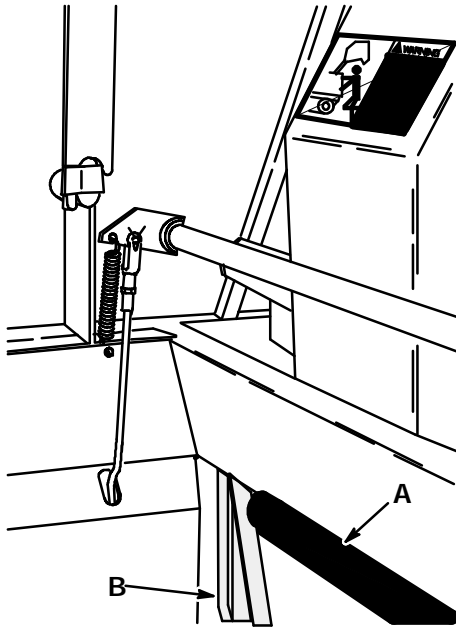

HOPPER SEALS

03369

- A. Top Hopper Seal**
- B. Side Hopper Seal**

- Remove the existing seal or skirt.
- Mount the new seal or skirt to the machine with the retaining strip removed earlier.
- Replace the side access doors if removed.
- Raise the hopper, place the hopper support bar in its storage position, and lower the hopper.

HOPPER DUMP DOOR SEAL

The hopper dump door seal allows the hopper to be high dumped without scattering debris. Check the seal for damage after every 100 hours of operation.

TO REPLACE HOPPER DUMP DOOR SEAL

- Empty the debris hopper.
- Raise the hopper.

- Engage the hopper support bar.

! WARNING: Falling Hopper. Engage Hopper Support Bar. Read Manual.

- Stop the engine and set the machine parking brake.

FOR SAFETY: Before Leaving Or Servicing Machine; Stop On Level Surface, Set Parking Brake, Turn Off Machine And Remove Key.

- Open the dump door.
- Remove the seal retaining strip.

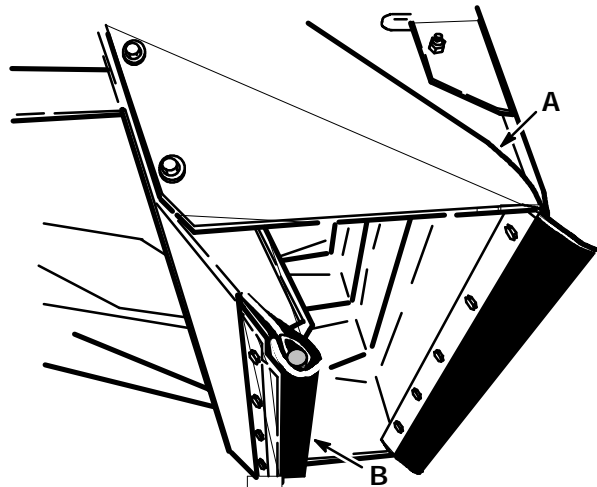

HOPPER DUMP DOOR SEAL

03384

- A. Hopper**
- B. Dump Door Seal**

- Remove the seal.
- Mount the new seal to the door with the sponge core and retaining strip removed earlier.
- Raise the hopper, position the hopper support bar in its storage position, and lower the hopper.

VACUUM FAN SEAL

The vacuum fan seal seals the vacuum fan to the filter cover. Check the seal for damage after every 100 hours of operation.

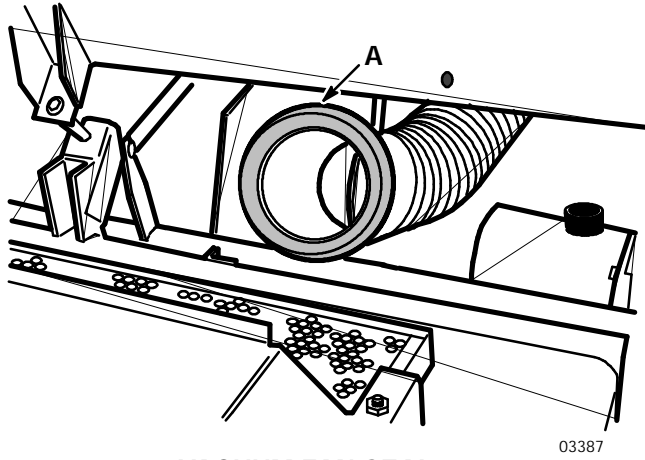

VACUUM FAN SEAL

A. Vacuum Fan Seal

FILTER COVER SEAL

The filter cover seal seals the filter box to the filter cover. Check the seal for damage after every 100 hours of operation.

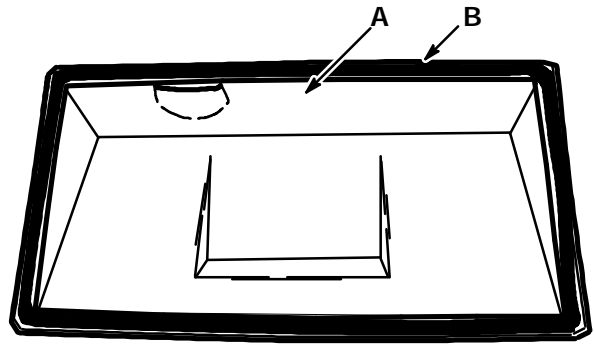

FILTER COVER SEAL

03375

A. Filter Cover
B. Seal

BRAKES AND TIRES

BRAKES

The foot brake and the parking brake operate the linkage which controls the brakes on the front wheels.

The foot brake needs no regular adjustment. The parking brake should be adjusted after every 200 hours of operation or whenever it becomes very easy to set.

To adjust the parking brake, turn the knurled knob on the end of the parking brake clockwise. If the knob adjustment is inadequate, remove the clevis pin from each brake assembly, turn the clevis ends an equal amount, reconnect the clevis pins, and readjust the parking brake.

TIRES

The front machine tires are solid. The rear tire is pneumatic. Proper air pressure is 90 psi (620 kPa). They should be inspected for wear after every 100 hours of operation.

REAR WHEEL

Torque the rear wheel nuts in a star pattern to 122 to 150 Nm (90 to 110 ft lb) after the first 50-hours of operation, and every 800 hours there after.

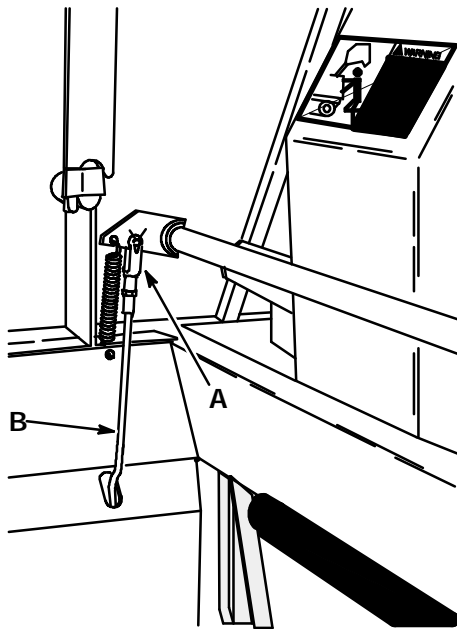

BRAKE ASSEMBLY

03369

- A. Clevis
- B. Brake Rod

SECTION 4

CONTENTS

	Page
HARDWARE INFORMATION	4-3
STANDARD BOLT TORQUE CHART ..	4-3
METRIC BOLT TORQUE CHART	4-3
BOLT IDENTIFICATION	4-3
THREAD SEALANT AND LOCKING COMPOUNDS	4-3
HYDRAULIC FITTING INFORMATION	4-4
HYDRAULIC TAPERED PIPE FITTING (NPT) TORQUE CHART	4-4
HYDRAULIC TAPERED SEAT FITTING (JIC) TORQUE CHART	4-4
HYDRAULIC O-RING FITTING TORQUE CHART	4-4

HARDWARE INFORMATION

The following charts state standard plated hardware tightening ranges for normal assembly applications. Decrease the specified torque by 20% when using a thread lubricant. Do not substitute lower grade hardware for higher grade hardware. If higher grade hardware than specified is substituted, tighten only to the specified hardware torque value to avoid damaging the threads of the part being threaded into, as when threading into speed nuts or weldments.

Front wheel nut - 10 to 12 ft lb (14 to 16 Nm) while turning wheel, tighten to spec, then backoff, retighten by hand till snug, then turn to next slot.

Rear hub to shaft nut - 175 ft lb (240 Nm) then to next slot.





Damper solenoid nut - 20 to 23 in lb (2.5 to 3 Nm).

STANDARD BOLT TORQUE CHART

Thread Size	SAE Grade 5 Torque ft lb (Nm)	SAE Grade 8 Torque ft lb (Nm)
0.25 in	7-10 (9-14)	10-13 (14-38)
0.31 in	15-20 (20-27)	20-26 (27-35)
0.38 in	27-35 (37-47)	36-47 (49-64)
0.44 in	43-56 (58-76)	53-76 (72-103)
0.50 in	65-85 (88-115)	89-116 (121-157)
0.62 in	130-170 (176-231)	117-265 (159-359)
0.75 in	215-280 (291-380)	313-407 (424-552)
1.00 in	500-650 (678-881)	757-984 (1026-1334)

NOTE: Decrease torque by 20% when using a thread lubricant.

BOLT IDENTIFICATION

Identification Grade Marking	Specification and Grade
	SAE-Grade 5
	SAE-Grade 8
	ISO-Grade 8.8
	ISO-Grade 10.9

01395

METRIC BOLT TORQUE CHART

Thread Size	Class 8.8 Torque ft lb (Nm)	Class 10.9 Torque ft lb (Nm)
M4	2 (3)	3 (4)
M5	4 (5)	6 (8)
M6	7 (9)	10 (14)
M8	18 (24)	25 (34)
M10	32 (43)	47 (64)
M12	58 (79)	83 (112)
M14	94 (127)	133 (180)
M16	144 (195)	196 (265)
M20	260 (352)	336 (455)
M24	470 (637)	664 (900)

NOTE: Decrease torque by 20% when using a thread lubricant.

Exceptions to the above chart:

Main brush drive plug nut - 30 ft lb (40 Nm) then tighten to next slot.

Brake unit to hub sockethead screw - 9 to 12 ft lb (12 to 16 Nm) with Loctite 242 blue.

THREAD SEALANT AND LOCKING COMPOUNDS

Thread sealants and locking compounds may be used on this machine. They include the following:

Loctite 515 sealant - gasket forming material. TENNANT Part No. 75567, 15 oz (440 ml) cartridge.

Loctite 242 blue - medium strength thread locking compound. TENNANT Part No. 32676, 0.5 ml tube.

Loctite 271 red - high strength thread locking compound. TENNANT Part No. 19857, 0.5 ml tube.

HYDRAULIC FITTING INFORMATION

**HYDRAULIC TAPERED PIPE FITTING (NPT)
TORQUE CHART**

NOTE: Ratings listed are when using teflon thread seal.

Size	Minimum Torque	Maximum Torque
1/4 NPT	10 ft lb (14 Nm)	30 ft lb (41 Nm)
1/2 NPT	25 ft lb (34 Nm)	50 ft lb (68 Nm)
3/4 NPT	50 ft lb (68 Nm)	100 ft lb (136 Nm)

**HYDRAULIC TAPERED SEAT FITTING (JIC)
TORQUE CHART**

Tube O.D. (in)	Thread Size	Maximum Torque
0.25	0.44-20	9 ft lb (12 Nm)
0.38	0.56-18	20 ft lb (27 Nm)
0.50	0.75-16	30 ft lb (41 Nm)
0.62	0.88-14	40 ft lb (54 Nm)
0.75	1.12-12	70 ft lb (95 Nm)
1.0	1.31-12	90 ft lb (122 Nm)

**HYDRAULIC O-RING FITTING TORQUE
CHART**

Tube O.D.(in)	Thread Size	Minimum Torque	Maximum Torque
0.25	0.44-20	6 ft lb (8 Nm)	9 ft lb (12 Nm)
0.38	0.56-18	13 ft lb (18 Nm)	20 ft lb (27 Nm)
		*10 ft lb (14 Nm)	12 ft lb (16 Nm)
0.50	0.75-16	20 ft lb (27 Nm)	30 ft lb (41 Nm)
		*21 ft lb (28 Nm)	24 ft lb (33 Nm)
0.62	0.88-14	25 ft lb (34 Nm)	40 ft lb (54 Nm)
0.75	1.12-12	45 ft lb (61 Nm)	70 ft lb (95 Nm)
1.0	1.31-12	60 ft lb (81 Nm)	90 ft lb (122 Nm)

NOTE: Do not use sealant on o-ring threads.

*Aluminum bodied components