



550

(Diesel)

(S/N 006115-)

Rider Scrubber Operator Manual

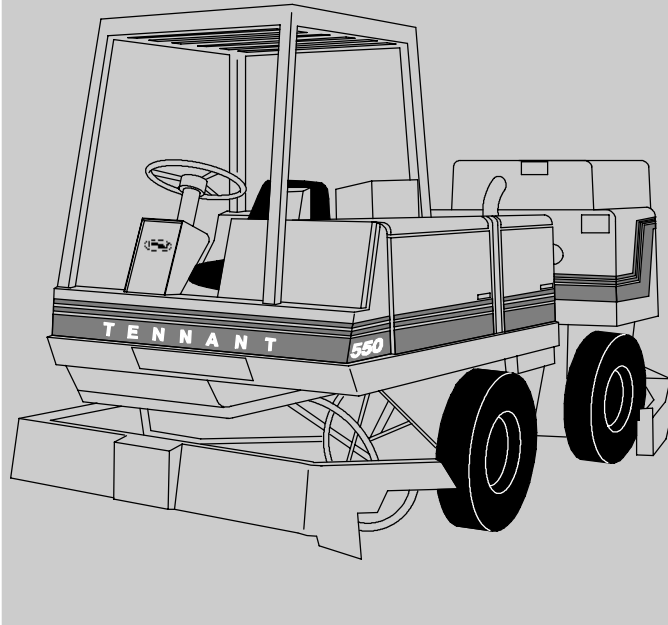

TennantTrue™ Parts and Supplies

North America / International

www.tennantco.com

330670
Rev. 09 (3-2011)



This manual is furnished with each new model. It provides necessary operation and maintenance instructions.



Read this manual completely and understand the machine before operating or servicing it.

This machine will provide excellent service. However, the best results will be obtained at minimum costs if:

- The machine is operated with reasonable care.
- The machine is maintained regularly - per the machine maintenance instructions provided.
- The machine is maintained with manufacturer supplied or equivalent parts.



PROTECT THE ENVIRONMENT

Please dispose of packaging materials, old machine components such as batteries, hazardous fluids including antifreeze and oil, in an environmentally safe way according to local waste disposal regulations.



Always remember to recycle.

MACHINE DATA

Please fill out at time of installation for future reference.

Model No. - _____

Serial No. - _____

Machine Options - _____

Sales Rep. - _____

Sales Rep. phone no. - _____

Customer Number - _____

Installation Date - _____

Tennant Company

PO Box 1452

Minneapolis, MN 55440

Phone: (800) 553-8033 or (763) 513-2850

www.tennantco.com



CALIFORNIA PROPOSITION 65 WARNING:

Engine exhaust from this product contains chemicals known to the State of California to cause cancer, birth defects, or other reproductive harm.

SRS is a US registered trademark of Tennant Company.

Specifications and parts are subject to change without notice.

Original instructions, Copyright © 1999-2002, 2004, 2006-2008, 2010, 2011 TENNANT Company, Printed in U.S.A.

CONTENTS

	Page		Page
SAFETY PRECAUTIONS	5	ENGINE OIL PRESSURE LIGHT (For	
OPERATION	8	machines serial number 007003	
PREPARATION FOR OPERATION	8	and above)	15
AFTER UNLOADING AND BEFORE		ENGINE COOLANT TEMPERATURE	
OPERATING THE MACHINE:	8	GAUGE	15
OPERATION OF CONTROLS	9	SQUEEGEE SWITCH	15
MACHINE COMPONENTS	9	SCRUB BRUSH LEVER	15
INSTRUMENTS AND CONTROLS (For		SCRUB HEAD POSITION LEVER	16
machines below serial number		SRS LIQUID LOW LEVEL LAMPS	
007003)	10	(OPTION)	16
INSTRUMENTS AND CONTROLS (For		SRS CLEANING SOLUTION FLOW	
machines serial number 007003 and		KNOB (OPTION)	16
above)	11	SOLUTION LEVER	16
BRAKE PEDAL	12	THROTTLE LEVER	16
DIRECTIONAL PEDAL	12	THROTTLE SWITCH (For machines	
OPERATOR SEAT	12	serial number 006409-007002))	16
SCRUB HEAD LOCK LEVER	12	MACHINE OPERATION	17
PIVOT LOCK PIN	13	NORMAL SCRUBBING OPERATION ..	17
PARKING BRAKE LEVER	13	PRE-START CHECKLIST	17
AMMETER (For machines below serial		TO START MACHINE	17
number 007003)	13	TO FILL SOLUTION TANK	17
CHARGING SYSTEM LIGHT (For		TO SCRUB	18
machines serial number 007003 and		TO DRAIN AND CLEAN RECOVERY	
above)	13	TANK AND EMPTY HOPPER	19
SQUEEGEE POSITION LAMP (For		POST OPERATION CHECKLIST -	
machines below serial number		ENGINE OPERATING	20
007003)	13	TO STOP MACHINE	20
TANK DRAIN LAMP (OPTION)	13	POST OPERATION CHECKLIST -	
SCRUB BRUSH PRESSURE LAMP		ENGINE STOPPED	20
(OPTION)	13	DOUBLE SCRUBBING OPERATION ..	20
IGNITION SWITCH	13	OPERATION ON GRADES	20
DIESEL PRE-HEAT INDICATING LAMP	14	MACHINE TROUBLESHOOTING	21
OPERATING LIGHTS SWITCH		OPTIONS OPERATION	22
(OPTION)	14	HIGH PRESSURE SPRAYER	22
ROTATING LIGHT SWITCH (OPTION) .	14	TO OPERATE HIGH PRESSURE	
HAZARD LIGHT SWITCH (OPTION) ...	14	SPRAYER	22
FUEL LEVEL GAUGE	14	VACUUM WAND	20
PANEL LAMP (OPTION)	14	TO OPERATE VACUUM WAND ..	22
ENGINE HOUR METER	14	TOWING AND TRANSPORTING THE	
STEERING WHEEL	14	MACHINE	23
HORN BUTTON (For machines serial		TOWING THE MACHINE	23
number 007003 and above)	14	TRANSPORTING THE MACHINE ..	23
FUSES (For machines below serial		MACHINE JACKING LOCATIONS	25
number 007003)	14	MACHINE STORAGE	26
FUSES (For machines serial number		STORING MACHINE	26
007003 and above)	14	DIESEL POWERED MACHINES ...	26
CIRCUIT BREAKERS (For machines			
serial number 007003 and above) ..	15		
ENGINE OIL PRESSURE GAUGE-			
CONTINENTAL ENGINES (For			
machines below serial number			
006409)	15		
ENGINE OIL PRESSURE GAUGE			
PERKINS ENGINES (For machines			
serial number 006409-007002) ..	15		

CONTENTS

	Page		Page
MAINTENANCE	27	FUEL INJECTION PUMP	42
RECOMMENDED FIRST 50-HOUR		FUEL INJECTORS	42
MACHINE INSPECTION	27	PRIMING THE FUEL SYSTEM -	
MAINTENANCE CHART	28	CONTINENTAL ENGINES (For	
LUBRICATION	30	machines below serial number	
ENGINE	30	006409)	43
VACUUM FAN SHAFT	30	PRIMING THE FUEL SYSTEM -	
MACHINE PIVOT	30	PERKINS ENGINES (For machines	
SCRUB HEAD PIVOT	31	serial number 006409-007002) ..	43
SCRUB HEAD HINGES	31	CYLINDER HEAD	44
REAR SQUEEGEE CASTERS	31	CYLINDER HEAD BOLT TIGHTENING -	
SCRUB BRUSH IDLER PLUGS	31	CONTINENTAL ENGINES (For	
REAR WHEELS	31	machines below serial	
HYDRAULICS	32	number 006409)	44
HYDRAULIC FLUID	32	CYLINDER HEAD BOLT TIGHTENING	
HYDRAULIC FLUID RESERVOIR	32	PERKINS ENGINES (For machines	
TO DRAIN THE HYDRAULIC		serial number 006409-007002) ..	44
FLUID RESERVOIR	33	VALVE TAPPET CLEARANCE	45
TO FILL THE HYDRAULIC		ELECTRICAL SYSTEM	46
FLUID RESERVOIR	33	BATTERY	46
HYDRAULIC FLUID RESERVOIR		BELTS AND CHAINS	47
BREATHER	34	VACUUM FAN DRIVE BELT	47
HYDRAULIC FLUID FILTER	34	TO ADJUST VACUUM FAN DRIVE	
TO REPLACE THE HYDRAULIC		BELT	47
FLUID FILTER ELEMENT	34	ALTERNATOR AND RADIATOR	
HYDRAULIC FLUID LEAKS	34	FAN BELT	47
HYDRAULIC COMPONENTS		TO ADJUST ALTERNATOR AND	
TROUBLESHOOTING	35	RADIATOR FAN BELT	47
ENGINE	36	SCRUB HEAD	48
LUBRICATION	36	TO ADJUST SCRUB HEAD HEIGHT ..	48
COOLING SYSTEM	36	TO ADJUST SCRUB BRUSH PATTERN	48
AIR INTAKE SYSTEM	37	SCRUB BRUSHES	50
AIR FILTER SERVICE INDICATOR ..	37	TO REPLACE SCRUB BRUSHES ..	50
AIR FILTER	37	SOLUTION SYSTEM	52
TO REPLACE AIR FILTER ELEMENT -		RECOVERY TANK	52
CONTINENTAL ENGINES (For		WATER SPRAY DEFLECTOR	52
machines below serial number		SRS WATER SPRAY DEFLECTOR	53
006409)	38	SRS SOLUTION TANK	54
TO REPLACE AIR FILTER ELEMENT -		SOLUTION DISPENSING TUBE	55
PERKINS OR CAT ENGINES (For		SRS METERING SOLUTION PUMP ..	55
machines serial number 006409		TROUBLESHOOTING	55
and above)	39	SQUEEGEES	56
FUEL SYSTEM	40	SIDE SQUEEGEES	56
FUEL WATER TRAP	40	REAR SQUEEGEE	56
TO CLEAN WATER TRAP	40	TO REPLACE REAR SQUEEGEE	
FUEL FILTER	40	BLADES	57
TO REPLACE FUEL FILTER -		TO FACTORY ADJUST REAR	
CONTINENTAL ENGINES (For		SQUEEGEE	57
machines below serial		TO ADJUST REAR SQUEEGEE ..	60
number 006409)	40	BRAKES AND TIRES	62
TO REPLACE FUEL FILTER -		SERVICE BRAKES	62
PERKINS ENGINES (For machines		PARKING BRAKES	63
serial number 006409-007002)	41	TIRES	63
WATER SEPARATOR/FUEL FILTER -		OPTIONS	64
CAT ENGINES (For machines serial		HIGH PRESSURE SPRAYER	64
number 007003 and above) ..	41		
IN-LINE FUEL FILTER - PERKINS			
ENGINES (For machines serial			
number 006409-007002)	42		

	Page
MACHINE SPECIFICATIONS	65
POWER TYPE	65
CONTINENTAL ENGINES - (For machines below serial number 006409)	65
PERKINS ENGINES - (For machines serial number 006409-007002)	65
CAT ENGINES - (For machines serial number 007003 and above)	65
POWER TRAIN	65
STEERING	65
HYDRAULIC SYSTEM	66
BRAKING SYSTEM	66
SUSPENSION SYSTEM	66
SYSTEM FLUID CAPACITIES	66
GENERAL MACHINE	
DIMENSIONS/CAPACITIES	67
MACHINE WEIGHTS	67
GENERAL MACHINE PERFORMANCE ...	67
MACHINE DIMENSION	68
INDEX	69

SAFETY PRECAUTIONS

The following symbols are used throughout this manual as indicated in their descriptions:



WARNING: To warn of hazards or unsafe practices which could result in severe personal injury or death.

FOR SAFETY: To identify actions which must be followed for safe operation of equipment.

The following information signals potentially dangerous conditions to the operator or equipment. Read this manual carefully. Know when these conditions can exist. Locate all safety devices on the machine. Then, take necessary steps to train machine operating personnel. Report machine damage or faulty operation immediately. Do not use the machine if it is not in proper operating condition.



WARNING: Engine Emits Toxic Gases. Severe Respiratory Damage Or Asphyxiation Can Result. Provide Adequate Ventilation. Consult With Your Regulatory Agency For Exposure Limits. Keep Engine Properly Tuned.



WARNING: Machine Can Emit Excessive Noise. Consult With Your Regulatory Agency For Exposure Limits. Hearing Loss Can Result. Wear Hearing Protection.



WARNING: Flammable Materials Can Cause An Explosion Or Fire. Do Not Pick Up Flammable Materials. Do Not Use Flammable Materials In Tank To Clean Floor.



WARNING: Flammable materials or reactive metals can cause explosion or fire. Do not pick up.



WARNING: Moving Belt. Keep Away.



WARNING: Moving Fan Blades. Keep Away.



WARNING: Raised Scrub Head May Fall. Block Scrub Head Up.



WARNING: Crush Hazard Between Front And Rear Halves Of Machine. Engage Pivot Lock.



WARNING: Heavy LP Tank May Fall. Remove LP Tank Before Opening Cover.



WARNING: Strong Vacuum. Keep Away From Fan Inlet When Fan Is Running.

FOR SAFETY:

1. Do Not Operate Machine:
 - Unless Trained And Authorized.
 - Unless Operation Manual Is Read And Understood.
 - Unless mentally and physically capable of following machine instructions.
 - In Flammable Or Explosive Areas Unless Designed For Use In Those Areas.
 - In Areas With Possible Falling Objects Unless Equipped With Overhead Guard.
2. Before Starting Machine:
 - Check For Fuel Leaks.
 - Keep Sparks And Open Flame Away From Refueling Area.
 - Make Sure All Safety Devices Are In Place And Operate Properly.
 - Check Brakes And Steering For Proper Operation.
3. When Starting Machine:
 - Keep Foot On Brake And Directional Pedal In Neutral.
4. When Using Machine:
 - Use Brakes To Stop Machine.
 - Go Slow On Grades And Slippery Surfaces.
 - Use Care When Backing Machine.
 - Do Not Carry Riders On Machine.
 - Always Follow Safety And Traffic Rules.
 - Report Machine Damage of Faulty Operation Immediately.
 - Follow mixing, handling and disposal instructions on chemical containers.
 - Follow safety guidelines concerning wet floors.
5. Before Leaving Or Servicing Machine:
 - Stop On Level Surface.
 - Set Parking Brake.
 - Turn Off Machine And Remove Key.

SAFETY PRECAUTIONS

6. When Servicing Machine:

- Avoid Moving Parts. Do Not Wear Loose Jackets, Shirts, Or Sleeves.
- Block Machine Tires Before Jacking Machine Up.
- Jack Machine Up At Designated Locations Only. Block Machine Up With Jack Stands.
- Use A Hoist Or Jack That Will Support The Weight Of The Machine.
- Wear Eye And Ear Protection When Using Pressurized Air Or Water.
- Disconnect Battery Connections Before Working On Machine.
- Avoid Contact With Battery Acid.
- Avoid Contact With Hot Engine Coolant.
- Allow Engine To Cool.
- Keep Flames And Sparks Away From Fuel System Service Area. Keep Area Well Ventilated.
- Use Cardboard To Locate Leaking Hydraulic Fluid Under Pressure.
- Use TENNANT Supplied Or Approved Replacement Parts.

7. When loading/unloading machine onto/off truck or trailer:

- Turn off machine.
- Use truck or trailer that will support the weight of the machine.
- Use winch. Do not drive the machine onto/off the truck or trailer unless the load height is 380 mm (15 in) or less from the ground.
- Set parking brake after machine is loaded.
- Block machine tires.
- Tie machine down to truck or trailer.

The following safety decals are mounted on the machine in the locations indicated. If these, or any decal becomes damaged or illegible, install a new decal in its place.

TRAVEL SPEED CAUTION DECAL -
LOCATED ON THE SIDE OPERATOR
PANEL

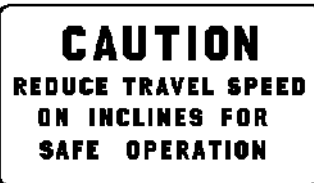

03785

FAN SUCTION DANGER DECAL -
LOCATED ON THE SOLUTION TANK

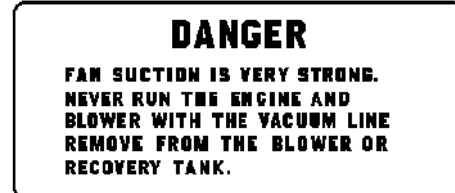

03786

SCRUB HEAD LOCK WARNING DECAL
- LOCATED ON THE SCRUB HEAD

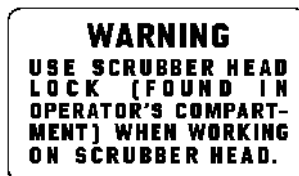

03787

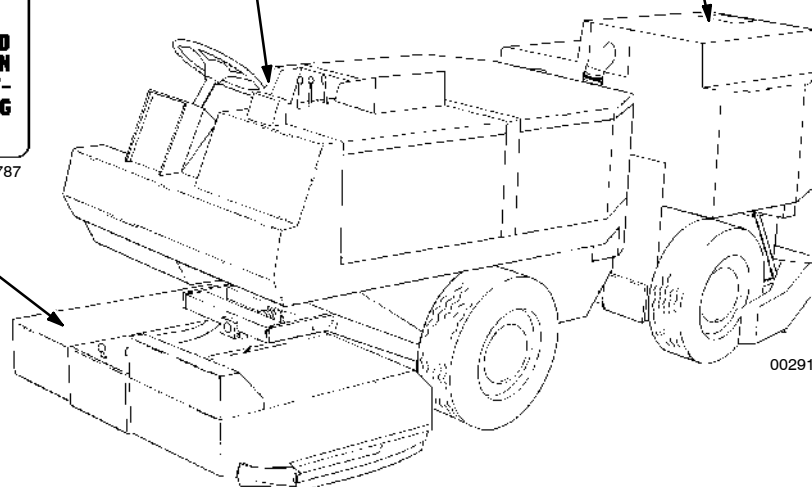

00291

FLAMMABLE MATERIALS WARNING DECAL - LOCATED IN THE OPERATOR COMPARTMENT



FLAMMABLE MATERIALS WARNING DECAL - LOCATED ON THE SOLUTION TANKS

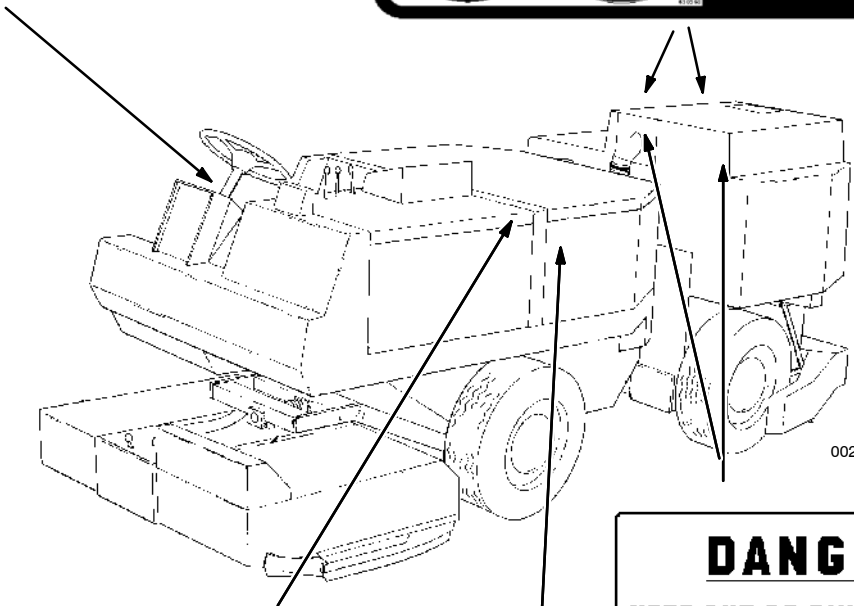

ENGINE FAN WARNING DECAL - LOCATED ON THE LEFT SIDE TOP ACCESS DOOR LIP



ENGINE FAN WARNING DECAL - LOCATED ON THE FAN SHROUD



PINCH SPACE DANGER DECAL - LOCATED ON THE SOLUTION TANK

PREPARATION FOR OPERATION

AFTER UNLOADING AND BEFORE OPERATING THE MACHINE:

1. Check the machine for shipping damage.
2. Read this manual carefully before operating or servicing the machine.

FOR SAFETY: Do Not Operate Machine Unless Operation Manual Is Read And Understood.

3. Check the hydraulic fluid level in the hydraulic fluid reservoir, using the dipstick provided. TENNANT hydraulic fluid is recommended. If TENNANT hydraulic fluid is not available, use only new, approved hydraulic fluid. See the *HYDRAULICS* in the *MAINTENANCE* section.
4. Check the engine oil level.
5. Check the radiator coolant level.
6. Check the brush adjustment, as described in *SCRUB HEAD* in the *MAINTENANCE* section.
7. Check the air pressure of the tires.
8. Fill the fuel tank on the machine per the instructions in this manual.

OPERATION OF CONTROLS

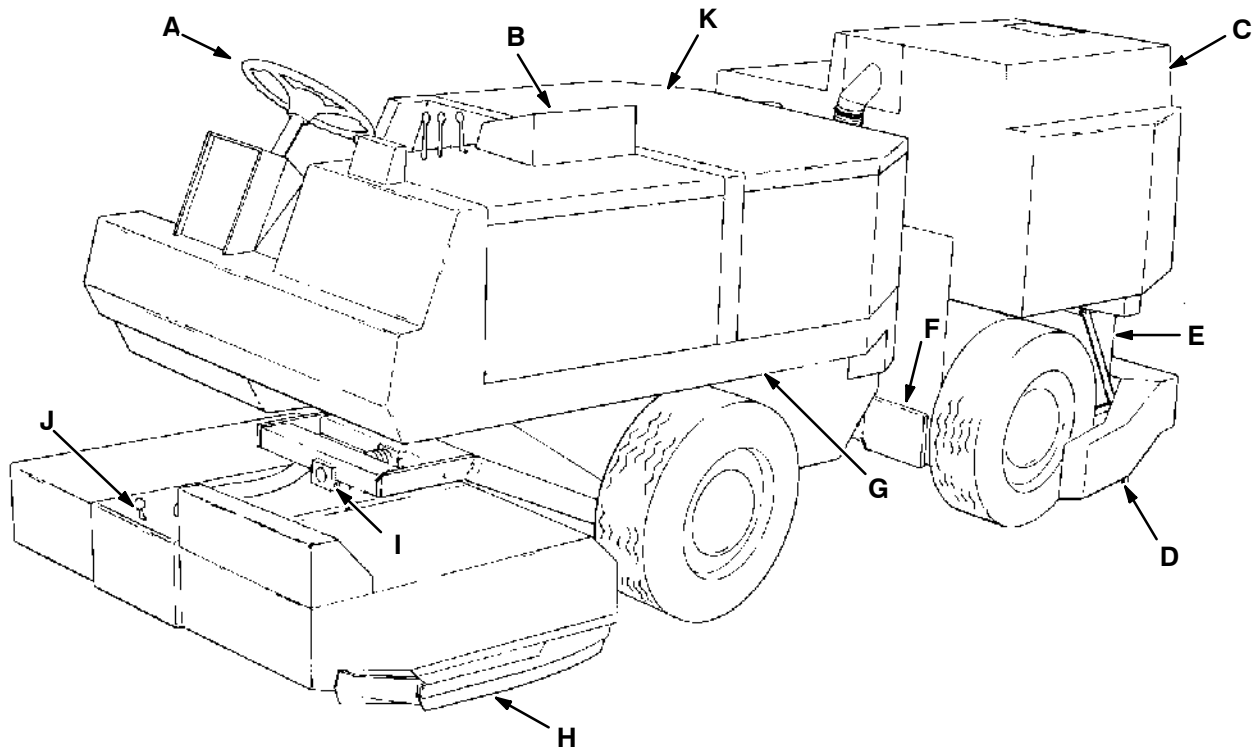

MACHINE COMPONENTS

00291

- | | |
|---------------------|--------------------------------|
| A. Steering Wheel | G. Articulated Joint |
| B. Instrument Panel | H. Side Squeegee |
| C. Solution Tank | I. Head Pivot |
| D. Rear Squeegee | J. Debris Trough Release Lever |
| E. Recovery Tank | K. Fuel Tank |
| F. Clean-out Door | |

OPERATION

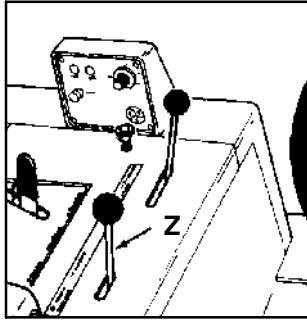

For machines below
serial number 006409

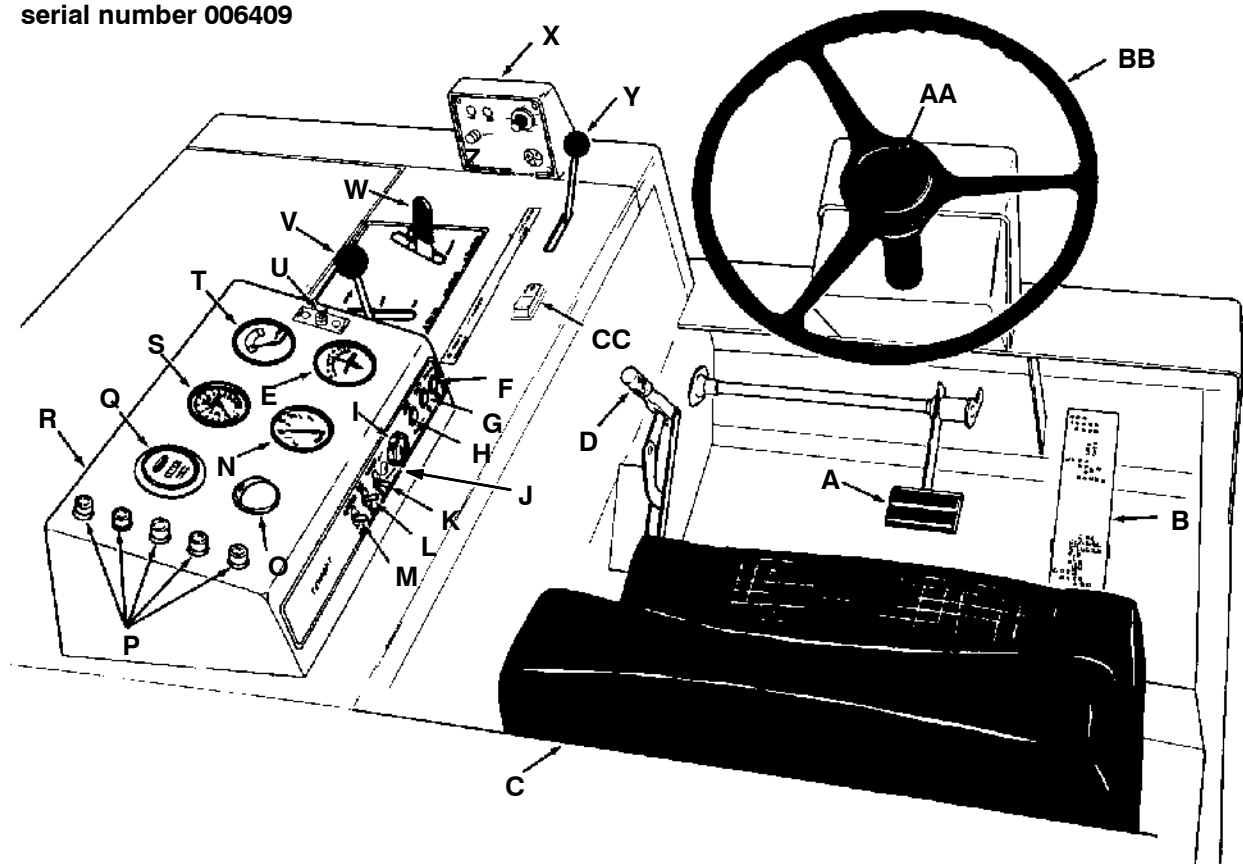

02353

INSTRUMENTS AND CONTROLS (For machines below serial number 007003)

- | | |
|---------------------------------------|-------------------------------------|
| A. Brake Pedal | P. Fuses |
| B. Directional Pedal | Q. Engine Hour Meter |
| C. Operator Seat | R. Instrument Panel |
| D. Parking Brake Lever | S. Oil Pressure Gauge |
| E. Ammeter | T. Engine Coolant Temperature Gauge |
| F. Squeegee Position Lamp | U. Squeegee Switch |
| G. Tank Drain Lamp (Option) | V. Scrub Brush Lever |
| H. Scrub Brush Pressure Lamp (Option) | W. Scrub Head Position Lever |
| I. Ignition Switch | X. SRS Panel (Option) |
| J. Diesel Pre-Heat Indicating Lamp | Y. Solution Lever |
| K. Operating Lights Switch (Option) | Z. Throttle Lever |
| L. Rotating Light Switch (Option) | AA. Horn Button |
| M. Hazard Light Switch (Option) | BB. Steering Wheel |
| N. Fuel Level Gauge | CC. Throttle Switch |
| O. Panel Lamp (Option) | |

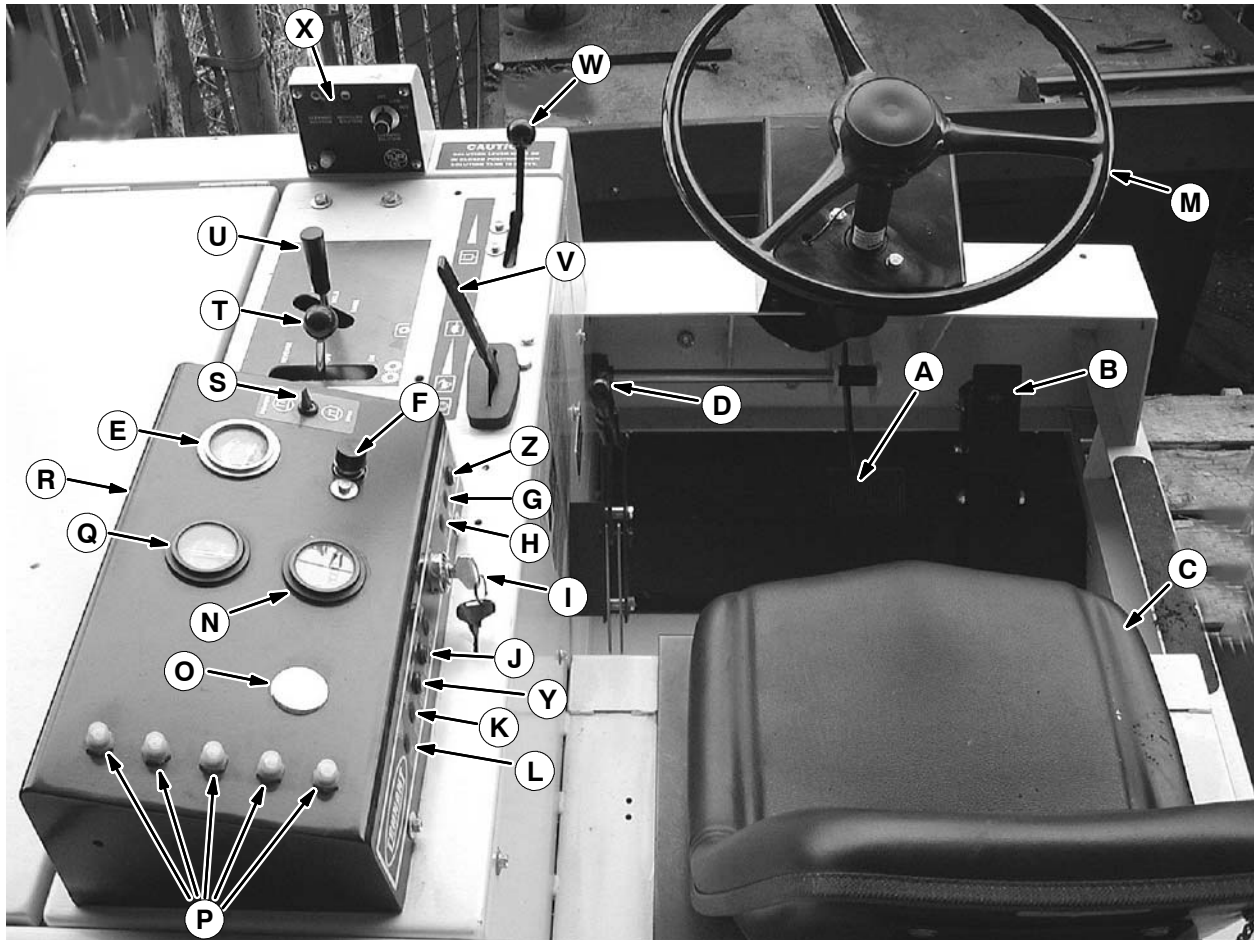

02353

INSTRUMENTS AND CONTROLS (For machines serial number 007003 and above)

- | | |
|---|----------------------------------|
| A. Brake Pedal | P. Circuit Breakers |
| B. Directional Pedal | Q. Engine Hour Meter |
| C. Operator Seat | R. Instrument Panel |
| D. Parking Brake Lever | S. Squeegee Switch |
| E. Engine Coolant Temperature Gauge | T. Scrub Brush Lever |
| F. Horn Button | U. Scrub Head Position Lever |
| G. Tank Drain Lamp (Option) | V. Throttle Lever |
| H. Scrub Brush Pressure Lamp (Option) | W. Solution Lever |
| I. Ignition Switch | X. SRS Panel (Option) |
| J. Diesel Pre-Heat Indicating Lamp | Y. Low Engine Oil Pressure Light |
| K. Operating Lights Switch (Option) | Z. Charging System Light |
| L. Rotating or Hazard Light Switch (Option) | |
| M. Steering Wheel | |
| N. Fuel Level Gauge | |
| O. Panel Lamp (Option) | |

OPERATION

BRAKE PEDAL

The brake pedal operates the brakes on the two front wheels.

To stop the machine, return the directional control pedal to neutral; then apply pressure to the brake pedal.

DIRECTIONAL PEDAL

A single foot pedal controls the propelling drive. The foot pedal is used to select the direction of travel and the speed of the machine.

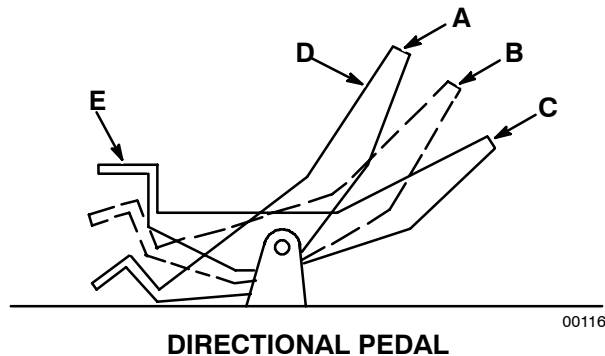

- A. "Reverse" Position
- B. "Neutral" Position
- C. "Forward" Position
- D. "Toe" Portion
- E. "Heel" Portion

Gradually press the "toe" portion of the pedal for forward travel or the "heel" portion of the pedal for reverse travel. Regulate the speed of the machine by varying the pressure on the pedal.

NOTE: Always use the brake pedal for normal stopping and controlling machine speed on down grades.

OPERATOR SEAT

The operator seat is of a fixed back style with a forward-backward adjustment. To adjust the seat, loosen the seat mounting bolts, slide the seat to the position desired, and tighten the bolts.

SCRUB HEAD LOCK LEVER

The scrub head lock lever controls the scrub head lock mechanism. This locks the scrub head, preventing it from lowering.

To set the scrub head lock, fully raise the scrub head. Then push the scrub head lock lever into the "LOCK" position.

To release the scrub head lock, fully raise the scrub head. Then pull the scrub head lock lever into the "UNLOCK" position.

Always set the scrub head lock before working under the scrub head. The scrub head lock must also be set whenever the machine will not be used for an extended period of time, overnight for example. Flat spots on the brushes will appear if the scrub head is left down for an extended period of time.

WARNING: Raised Scrub Head May Fall. Block Scrub Head Up.

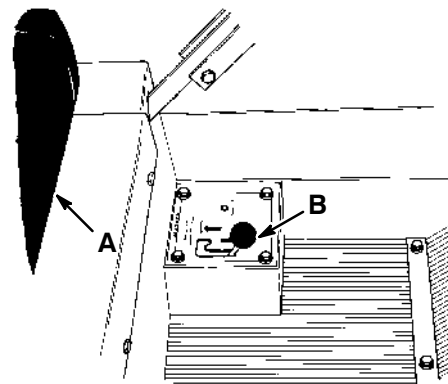

- A. Operator Seat
- B. Scrub Head Lock Lever

PIVOT LOCK PIN

The pivot lock pin is provided to lock the pivot joint between the front and rear machine sections. The pin is hung on the front section of the machine adjacent to the machine pivot.

To lock the sections, turn the machine so the pivot lock holes line up, then insert the pin in the lined up holes. The pin will prevent the machine from pivoting and creating a pinch area.

⚠ WARNING: Crush Hazard Between Front And Rear Halves Of Machine. Engage Pivot Lock.

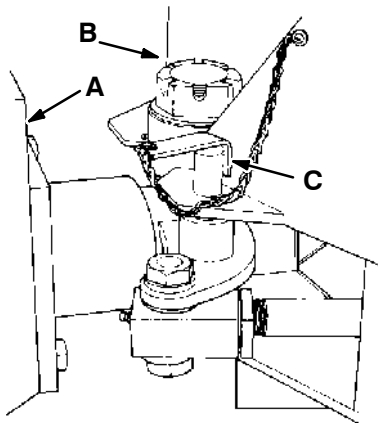

PIVOT LOCK PIN IN USE

- A. Machine Trailer Section**
- B. Machine Tractor Section**
- C. Pivot Lock Pin**

00251

PARKING BRAKE LEVER

The parking brake lever controls the brakes on the two front wheels. To set the parking brake pull the brake handle up. To release the parking brake push the brake handle down. Always set the parking brake before leaving the machine unattended and before working on the machine.

FOR SAFETY: Before Leaving Or Servicing Machine; Stop On Level Surface, Set Parking Brake, Turn Off Machine And Remove Key.

AMMETER (For machines below serial number 007003)

The ammeter registers the charging current which is being passed to the battery by the alternator. It also registers battery discharge used by the machine when the alternator is not charging.

CHARGING SYSTEM LIGHT (For machines serial number 007003 and above)

The charging system light comes on when the existing voltage potential of the battery is not within normal range (10 to 14 Volts). Stop operating the machine. Locate the problem and have it corrected.

SQUEEGEE POSITION LAMP (For machines below serial number 007003)

The squeegee position lamp lights when the squeegee is either fully raised or lowered. This can be helpful to the operator when the squeegee is not visible.

TANK DRAIN LAMP (OPTION)

The tank drain lamp lights when the recovery tank is nearly full. The machine operator can then plan to return to a draining location.

SCRUB BRUSH PRESSURE LAMP (OPTION)

The scrub brush pressure lamp option lights when scrub brush down pressure is excessive, which may cause the brushes to stall. The operator should then check the brush position adjustment.

NOTE: This information holds true only after the hydraulic fluid has warmed up (about 10 to 15 minutes). If the light comes on after the oil is warm, the cause may be operating on a rough floor-use "restricted" brush down pressure.

IGNITION SWITCH

The key-operated ignition switch has four positions. Those positions are "accessories," "off," "on," and "start." To operate any electrical option without operating the engine, turn the switch to the "accessories" position.

To start the engine, turn the key to the "start" position. Do not engage the starter for more than ten seconds at a time, or after the engine has started, as the starter may be damaged. To stop the engine, turn the key to the "off" position.

FOR SAFETY: Before Starting Machine, Make Sure All Safety Devices Are In Place And Operate Properly.

OPERATION

DIESEL PRE-HEAT INDICATING LAMP

The diesel pre-heat indicating lamp is present on diesel powered machines. The lamp lights when the diesel pre-heater is operating.

OPERATING LIGHTS SWITCH (OPTION)

The operating lights switch is present on machines with the operating lights option. It controls the headlights, taillights, and the brush spot light. Flip the switch toggle upward to turn the lights on. Flip the switch toggle down to turn the lights off.

ROTATING LIGHT SWITCH (OPTION)

The rotating light switch is present on machines with the rotating light switch option. Flip the switch toggle up to turn the light on. Flip the switch toggle down to turn light off.

HAZARD LIGHT SWITCH (OPTION)

The hazard light switch is present on machines with the hazard light option. Flip the switch toggle up to turn the light on. Flip the switch toggle down to turn the light off.

FUEL LEVEL GAUGE

The fuel level gauge is present on all diesel powered machines. The gauge indicates how much fuel is left in the fuel tank.

PANEL LAMP (OPTION)

The panel lamp is present on machines with the operating lights option. The lamp lights whenever the operating lights switch toggle is flipped up to turn on the operating lights.

ENGINE HOUR METER

The hour meter records the number of hours the machine has been operated. This information is useful in determining when to service the machine.

STEERING WHEEL

The steering wheel controls a steering cylinder which is mounted between the two halves of the machine. Do not turn the steering wheel excessively when the engine is not running. An articulated trunnion connects the front and rear sections of the machine so that the rear section always follows the path of the front section. A horn button is located in the center of the steering wheel. (For machines below serial number 007003) a horn button is located in the center of the steering wheel.

HORN BUTTON (For machines serial number 007003 and above)

The horn button operates the horn. To sound the horn press the button.

FUSES (For machines below serial number 007003)

Fuses are a one-time circuit protection device designed to stop the flow of current in the event of a circuit overload. Never substitute higher value fuses than those specified in this manual. The chart below shows the various fuses and the electrical components they protect.

PROTECTIVE-DEVICE	RATING	CIRCUIT PROTECTED
Fuse	80 A	Glow Plugs
Fuse	15 A	Auto-Squeegee
Fuse	1 A	Recovery Tank Level Lamps
Fuse	1 A	SRS Tank Level Lamps
Fuse	15 A	Brush Pressure Lamp, Squeegee Pressure Lamps
Fuse	20 A	Rotating, Hazard Lights
Fuse	10 A	SRS Solution Pump

FUSES (For machines serial number 007003 and above)

Fuses are a one-time circuit protection device designed to stop the flow of current in the event of a circuit overload. Never substitute higher value fuses than those specified in this manual. The chart below shows the various fuses and the electrical components they protect.

PROTECTIVE-DEVICE	RATING	CIRCUIT PROTECTED
Fuse-1	150 A	Alternator
Fuse-2	15 A	Fuel Pump
Fuse-3	50 A	Glow Plugs

CIRCUIT BREAKERS (For machines serial number 007003 and above)

The circuit breakers are resettable electrical circuit protection devices. Their design stops the flow of current in the event of a circuit overload. Once a circuit breaker is tripped, it must be reset manually. Press the reset button after the breaker has cooled down.

If the overload that caused the circuit breaker to trip is still there, the circuit breaker will continue to stop current flow until the problem is corrected.

The chart lists the circuit breakers and the electrical components they protect.

Circuit Breaker	Rating	Circuit Protected
CB-1	15 A	Gauges
CB-2	20 A	Horn/Rotating, Hazard Lights/Turn Signal
CB-3	15 A	Operating Lights
CB-4	15 A	Squeegee
CB-5	15 A	SRS/Recovery Tank Level Lamps
CB-6	15 A	SRS Solution Pump

ENGINE OIL PRESSURE GAUGE-CONTINENTAL ENGINES (For machines below serial number 006409)

The engine oil pressure gauge registers the engine oil pressure. Normal engine oil pressure ranges from 7 psi (50 kPa) at idle, to 35 psi (240 kPa) at full engine throttle. If the gauge registers an oil pressure reading below 7 psi (50 kPa), stop the engine immediately and determine the cause. Failure to stop the engine will result in severe engine damage.

ENGINE OIL PRESSURE GAUGE PERKINS ENGINES (For machines serial number 006409-007002)

The engine oil pressure gauge registers the engine oil pressure. Normal engine oil pressure ranges from 9 psi (65 kPa) at idle, to 70 psi (485 kPa) at full engine throttle. If the gauge registers an oil pressure reading below 9 psi (65 kPa), stop the engine immediately and determine the cause. Failure to stop the engine will result in severe engine damage.

ENGINE OIL PRESSURE LIGHT (For machines serial number 007003 and above)

The engine oil pressure light comes on when the engine oil pressure falls below 5 psi (40 kPa). Stop operating the machine. Locate the problem and have it corrected.

ENGINE COOLANT TEMPERATURE GAUGE

The engine coolant temperature gauge registers the engine coolant temperature. Normal engine coolant temperatures range up to 200° F (93° C). Temperatures above this level indicate an over-heating engine. Over-heating may occur due to a low coolant level, a clogged radiator, a loose fan belt, a defective thermostat, or other engine malfunctions. Engine overheating will always cause a coolant loss. If coolant loss does not occur, check for malfunction of the temperature sending unit.

SQUEEGEE SWITCH

The squeegee switch, in conjunction with a hydraulic flow sensing device, and the scrub brush lever, controls the position of the rear squeegee.

To raise the squeegee, flip the switch toggle forward into the “Squeegee Up” position. This position cannot be overridden by the hydraulic flow sensing device.

To lower the squeegee, flip the switch toggle back into the “Down” position. The squeegee will lower when the machine starts moving in the forward direction. When traveling in the reverse direction, the hydraulic flow sensing device overrides the squeegee switch and raises the rear squeegee. This prevents the rear squeegees from being damaged when traveling in reverse. The squeegee switch should always be in the “Down” position when scrubbing.

SCRUB BRUSH LEVER

The scrub brush lever controls the scrub brush motors. To start the scrub brushes rotating in their normal direction, pull the lever into the “ON” position. To stop brush rotation, move the lever into the “OFF” position.

To start the scrub brushes rotating opposite their normal direction for double scrubbing, push the lever into the “REVERSE” position.

OPERATION

SCRUB HEAD POSITION LEVER

The scrub head position lever controls the position of the scrub head. To raise the scrub head, pull the lever back into the "RAISE" position. To stop scrub head movement move the lever to the "HOLD" position. To lower the scrub head, push the lever into the "LOWER" position.

SRS LIQUID LOW LEVEL LAMPS (OPTION)

The SRS liquid low level lamps option includes two indicating lamps. The cleaning solution lamp lights when the cleaning solution level is low. The recycling solution lamp lights when the recycling solution is low.

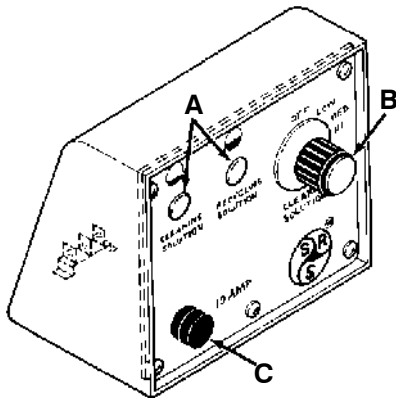

SRS CONTROL PANEL

00351

- A. Liquid Low Level Indicator Lamps
- B. Cleaning Solution Flow Knob
- C. SRS Pump System Fuse (For machines below serial number 007003)
- C. SRS Pump System Circuit Breaker (For machines serial number 007003 and above)

SRS CLEANING SOLUTION FLOW KNOB (OPTION)

The SRS cleaning solution flow knob controls the pumping of cleaning solution into the solution flow to the floor. The "LOW", "MED", and "HI" levels indicate the rate of cleaning solution flow.

The "LOW" level causes the pump to deliver one-fourth flow capacity, "MED" level one-half capacity, and "HI" level full pump capacity of cleaning solution into the solution flow to the floor. The "OFF" position shuts off the cleaning solution flow.

SOLUTION LEVER

The solution lever controls the solution control valve. To stop solution flow to the floor, push the lever into the "CLOSED" position. To start solution flow, pull the lever into the "OPEN" position.

THROTTLE LEVER

The throttle lever controls the engine governed speed and stops the engine. To speed the engine to the maximum governed speed, move the lever into the "FULL" position. To slow the engine to idle speed, move the lever to the "IDLE" position. To stop the engine, move the lever to the "STOP" position.

THROTTLE SWITCH (For machines serial number 006409-007002)

The throttle switch controls the engine governed speed. To speed the engine to the maximum governed speed, move the switch into the "FULL" position. To slow the engine to idle speed, move the switch to the "IDLE" position.

MACHINE OPERATION

NORMAL SCRUBBING OPERATION

A normal scrubbing operation consists of eight typical operations: pre-start checklist, starting machine, filling solution tank, scrubbing, draining recovery tank and emptying hopper, post operation checklist – engine operating, stopping machine, and post operation checklist – engine stopped.

PRE-START CHECKLIST lists things to check before starting the machine.

TO START MACHINE lists the steps required to start the machine.

TO FILL SOLUTION TANK lists the steps required to fill the solution tank.

TO SCRUB lists things to keep in mind before and during the scrubbing operation.

TO DRAIN RECOVERY TANK AND EMPTY HOPPER lists the steps required to empty the debris hopper and the recovery tank.

POST OPERATION CHECKLIST - ENGINE OPERATING lists things to check before stopping the machine engine.

TO STOP MACHINE lists the steps required to stop the machine.

POST OPERATION CHECKLIST - ENGINE STOPPED lists things to check after stopping the machine engine.

PRE-START CHECKLIST

Check under the machine for leak spots.

Check the engine lubricating oil level.

Check the engine air filter restriction indicator.

Check the fuel level.

Check the brakes and controls for proper operation.

Check the service records to determine service requirements.

TO START MACHINE

NOTE: Before starting machine, perform the pre-start checks.

1. The machine operator must be in the operator's seat with the directional pedal in the "neutral" position and with a foot on the brake pedal or with the parking brake set.

FOR SAFETY: Before Starting Machine, Make Sure All Safety Devices Are In Place And Operate Properly.

2. Cold engine: Turn the ignition key to the "on" position to start the diesel pre-heater. Wait until the pre-heater lamp goes off, then proceed to start the engine.

ATTENTION! Do not use a cold engine starting aid such as ether unless directed to by a representative of the engine manufacturer.

3. Move the throttle to the "IDLE" position.
4. Turn the ignition switch key to the "start" position until the engine starts. Do not operate the starter for more than ten seconds at a time or after the engine has started.

NOTE: Do not operate the starter motor for more than ten seconds at a time or after the engine has started. Allow the starter to cool between starting attempts. The starter motor may be damaged if it is operated incorrectly.

5. Allow the engine and hydraulic system to warm up three to five minutes.
6. Release the machine parking brake.
7. Drive the machine to the solution filling site.

OPERATION

TO FILL SOLUTION TANK

1. Stop the engine and set the parking brake.

FOR SAFETY: Before Leaving Or Servicing Machine; Stop On Level Surface, Set Parking Brake, And Turn Off Machine.

2. Open the solution tank fill door or cap.
3. Pour the required amount of detergent into the tank. Fill the tank with water to 1 in (25 mm) below the tank opening. The water must not be hotter than 130°F (54°C) or tank damage may occur.

FOR SAFETY: When using machine, follow mixing and handling instructions on chemical containers.

NOTE: If standing water is to be picked up in addition to the solution put down by machine, do not fill tank all of the way. This will allow more water to be picked up before the ball float shutoff is actuated.

SRS machines: Pour liquid detergent into the cleaning solution tank - not the solution tank. Do not use powdered detergent or any other detergent not designed for the SRS application. Replace the cleaning solution tank fill cap.

FOR SAFETY: When using machine, follow mixing and handling instructions on chemical containers.

NOTE: Floor conditions, water condition, amount of soilage, type of soilage, brush action, and squeegee action all play an important role in determining the type and the concentration of detergent to be used. For specific recommendations, contact the local TENNANT representative.



WARNING: Flammable Materials Can Cause An Explosion Or Fire. Do Not Use Flammable Materials In Tank(s).

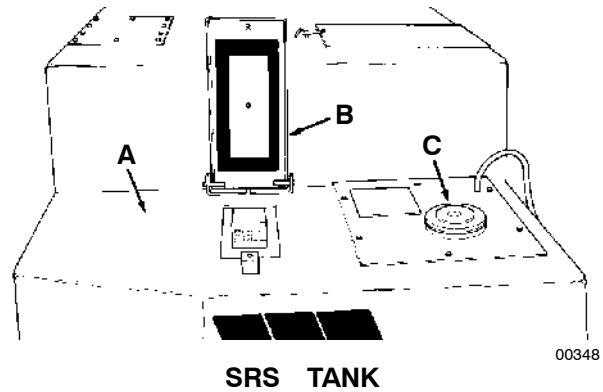

- A. Solution Tank**
- B. Solution Fill Door**
- C. Cleaning Solution Fill Cap**

4. Close the solution fill door.

TO SCRUB

Plan the scrubbing in advance. Try to arrange long runs with minimum stopping and starting. Do an entire floor or section at one time.

Pick up oversize debris before scrubbing. Remove bulky debris from aisles before scrubbing. Pick up pieces of wire, twine, string, etc., which could become entangled in brush or brush plugs.

Allow a few inches overlap of brush paths.

Do not turn steering wheel too sharply when the machine is in motion. It is very responsive to the movement of the steering wheel. Avoid sudden turns, except in emergencies.

Try to scrub as straight a path as possible. Avoid bumping into posts or scraping the sides of the machine.

1. Drive the machine to the area to be scrubbed.
2. Move the scrub head position lever to the "RAISE" position to release the scrub head lock.
3. Move the scrub head lock lever to the "UNLOCK" position.

4. Place the squeegee switch in the “Down” position.
5. Move the solution lever back to start the solution flow.

For SRS machines: Turn the cleaning solution knob to the desired cleaning solution flow.

6. Move the scrub brush lever to the “ON” position.
7. Scrub as required.

⚠ WARNING: Flammable materials or reactive metals can cause explosion or fire. Do not pick up.

TO DRAIN AND CLEAN RECOVERY TANK AND EMPTY HOPPER

1. Stop the engine and set the parking brake.

FOR SAFETY: Before Leaving Or Servicing Machine; Stop On Level Surface, Set Parking Brake, And Turn Off Machine.

2. Remove and unplug the tank drain hose next to a floor drain.

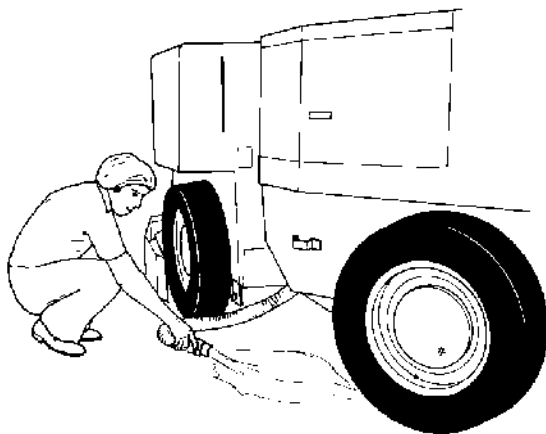

DRAINING RECOVERY TANK

00288

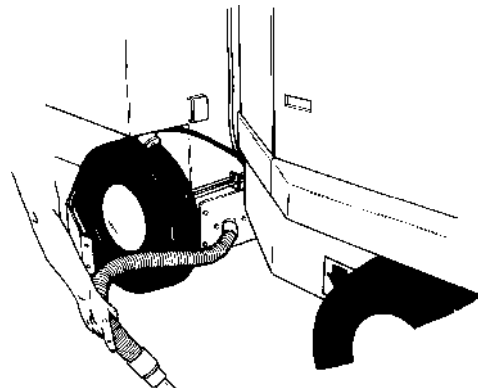

DRAINING SRS TANK

00343

3. Pull the debris trough lever to dump the debris trough.

NOTE: If a more gentle dumping action is desired, the trough can be dumped with the scrub head lowered; then the head can be raised hydraulically to slowly tip the trough.

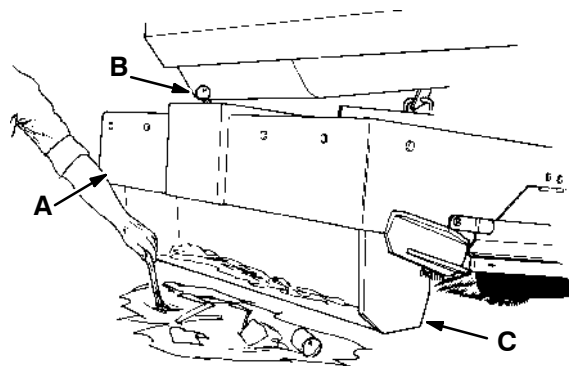

DUMPING DEBRIS TROUGH

00283

- A. Scrub Head**
- B. Debris Trough Lever**
- C. Debris Trough**

4. Clean the trough screen.
5. Clean the channel above the debris trough. If debris builds up in this area, the trough will not swing all the way up and latch properly. Remove any debris which has accumulated on top of the rail.
6. Close the debris trough.
7. Plug and secure the drain hose to the machine after tank is drained.
8. SRS machines: Partially fill the solution tank with clean water. Run the SRS pump for a few minutes to flush the solution hoses.

OPERATION

POST OPERATION CHECKLIST - ENGINE OPERATING

Check the scrub brush pattern for width and evenness.

Check the squeegees for proper deflection.

TO STOP MACHINE

1. Return the directional pedal to the "neutral" position. Apply the brake.
2. Move the solution lever to the "OFF" position.
3. Move the scrub head position lever to the "RAISE" position to set the scrub head lock.
4. Move the scrub head lock lever to the "LOCK" position.
5. Move the scrub brush lever to the "OFF" position.
6. Place the squeegee switch in the "Squeegee Up" position.
7. Turn off the operating lights if used.
8. Place the throttle in the "IDLE" position.
9. Set the machine parking brake.

FOR SAFETY: Before Leaving Or Servicing Machine; Stop On Level Surface, Set Parking Brake, Turn Off Machine And Remove Key.

10. Turn the ignition key switch to the "off" position. Remove the ignition key from the ignition switch.
11. Hold the throttle lever in the "STOP" position to stop the engine.

POST OPERATION CHECKLIST - ENGINE STOPPED

Check for wire or string tangled on the scrub brushes.

Check the squeegees for wear or damage.

Empty and clean the debris hopper.

Drain and clean the recovery tank.

Check the vacuum hoses for debris or obstructions.

Fill the fuel tank.

Check for leaks.

DOUBLE SCRUBBING OPERATION

Double pass scrubbing should be necessary only for heavy soilage and build-up of dirt, wax, etc. Operate the machine as desired for normal scrubbing but keep the rear squeegee up while making the first scrubbing pass. Allow the solution to soak on the floor for 15 to 20 minutes. Then make a second pass in the normal manner with the rear squeegee down.

FOR SAFETY: When Using Machine, Go Slow On Grades And Slippery Surfaces.

OPERATION ON GRADES

Drive the machine slowly on grades. Some loss of rear wheel steering traction could occur when braking with empty solution tanks.

The maximum rated ramp climb angle is 10°.

FOR SAFETY: When Using Machine, Go Slow On Grades And Slippery Surfaces.

MACHINE TROUBLESHOOTING

Problem	Cause	Remedy
Trailing water – poor or no water pickup	Worn rear squeegee	Rotate or replace rear squeegee blade
	Rear squeegee out of adjustment	Adjust rear squeegee
	Worn side squeegee	Replace side squeegee blade
	Side squeegee out of adjustment	Adjust side squeegee
	Vacuum hose clogged	Flush vacuum hoses
	Recovery tank full	Drain tank
	Float stuck shutting off vacuum	Clean float
	Vacuum fan drive belt loose or broken	Adjust, or replace and adjust belt
	Debris caught on squeegee	Remove debris
	Foam filling recovery tank	Empty recovery tank; use less or change detergent
	Vacuum hose to rear squeegee disconnected or damaged	Reconnect or replace vacuum hose
	Vacuum fan to recovery tank hose damaged	Replace hose
Little or no solution flow to floor	Solution tank empty	Fill solution tank
	Solution control linkage broken or out of adjustment	Replace and/or adjust linkage
	Solution supply lines plugged	Flush solution supply lines
	Solution spreader holes plugged	Flush spreader holes
Poor scrubbing performance	Debris caught on scrub brushes	Remove debris
	Improper detergent or brushes used	Check with Tennant representative for advice
	Worn scrub brushes	Replace scrub brushes
	Scrub brushes out of adjustment	Adjust scrub brushes
	Debris hopper full	Empty hopper
	Brushes have rotation set	Rotate brushes end-for-end
	Scrub brush drive failure	See <i>HYDRAULIC COMPONENTS TROUBLESHOOTING</i> – Hydraulic Motor Failure, in the <i>MAINTENANCE</i> section

OPTIONS OPERATION

HIGH PRESSURE SPRAYER

The high pressure sprayer option gives the machine the ability to spray wash grease, oil, and other dirt from trucks, racks, walls, etc. The water and detergent solution is taken from the solution supply line located under the operator seat. The solution is directed first to the spray pump which is driven off the machine hydraulic system. The spray pump has a 4 gpm (15 L/min) capacity up to 800 psi (5515 kPa). From the pump, the water flows through the hand-held sprayer.

NOTE: Pump only approved machine detergents and solutions through the high pressure sprayer. Acids and abrasive fluids may damage the unit.

The engine idle must be set between 700 and 850 rpm to allow the pump to operate at normal speed.

TO OPERATE HIGH PRESSURE SPRAYER

1. Set the machine parking brake.

FOR SAFETY: Before Leaving Or Servicing Machine; Stop On Level Surface, Set Parking Brake, And Turn Off Machine.

2. Start engine. Place the throttle in the "IDLE" position.

ATTENTION! Do not operate the high pressure sprayer at full engine throttle or the water pump will fail.

3. Open the shutoff valve on the scrub head.
4. Adjust water pressure to 800 psi (5515 kPa) using red pressure adjustment knob on regulator.

FOR SAFETY: When Servicing Machine, Wear Eye And Ear Protection When Using Pressurized Air Or Water.

5. Spray as required.

NOTE: Check the water spray pressure. It is to be 600 to 800 psi (4140 to 5515 kPa) when operating the sprayer. The maximum pressure when not spraying is 1200 psi (8275 kPa). To change the water pressure, adjust the red pressure adjustment knob on the regulator, or adjust the engine idle.

6. When finished, close the shutoff valve and relieve water pressure in the high pressure spray hose. Place all equipment in its proper storage location.

VACUUM WAND

The vacuum wand option gives the machine the added flexibility of picking up spills not accessible by the machine. A 20 ft (6095 mm) hose and wand utilizes the machine vacuum system.

TO OPERATE VACUUM WAND

1. Set the machine parking brake.

FOR SAFETY: Before Leaving Or Servicing Machine; Stop On Level Surface, Set Parking Brake, And Turn Off Machine.

2. Remove the vacuum wand and hose from storage on the machine.
3. Remove the rear squeegee vacuum hose plate from the rear of the tank.
4. Attach the vacuum wand hose plate to the rear of the tank using the toggle clamps provided.
5. Start the engine.
6. Move the throttle to the "FULL" position.
7. Operate the vacuum wand as required.
8. When finished, stop the engine, and remove the vacuum wand hose plate from the rear of the tank.
9. Reconnect the rear squeegee vacuum hose plate to the rear of the tank using the toggle clamps provided.
10. Clean and rinse off the vacuum wand, hose, and related equipment as required.
11. Store the vacuum wand equipment in the proper locations.

TOWING AND TRANSPORTING THE MACHINE

TOWING THE MACHINE

If the machine becomes disabled, it can be towed from the front or rear using the towing brackets located at the front or rear of the machine. This machine is not designed to be pushed.

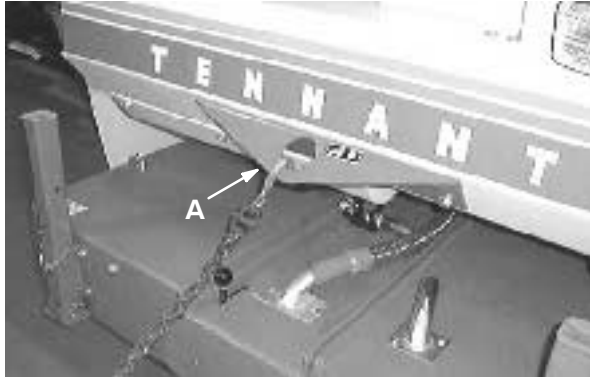

TOWING BRACKET

A. Towing Bracket

The propelling pump has a bypass valve to prevent damage to the hydraulic system when the machine is being towed. This valve allows a disabled machine to be moved a *very short distance* and at a speed to not exceed 1.6 kp/h (1 mph). The machine is NOT intended to be towed a long distance or at a high speed.

ATTENTION! Do not tow machine for a long distance and without using the bypass valve, or the machine hydraulic system may be damaged.

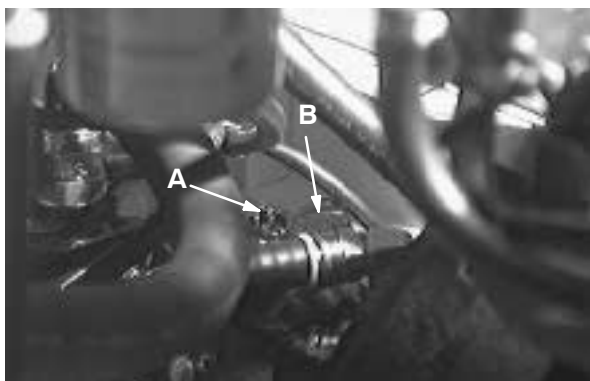

BYPASS VALVE

- A. Bypass Valve**
- B. Propelling Pump**

Turn the bypass valve 90° from the normal position before towing the machine.

TRANSPORTING THE MACHINE

1. Position the machine at the loading edge of the truck or trailer.

FOR SAFETY: Use truck or trailer that will support the weight of the machine.

NOTE: Empty the recovery and solution tanks before transporting the machine.

2. If the loading surface is not horizontal or is higher than 380 mm (15 in) from the ground, use a winch to load machine.

If the loading surface is horizontal AND is 380 mm (15 in) or less from the ground, the machine may be driven onto the truck or trailer.

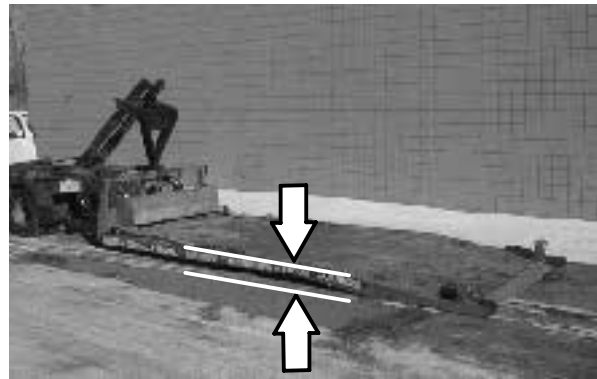

LOADING SURFACE

A. Loading Surface Height

3. To winch the machine onto the truck or trailer, attach the winching chain to the towing bracket.

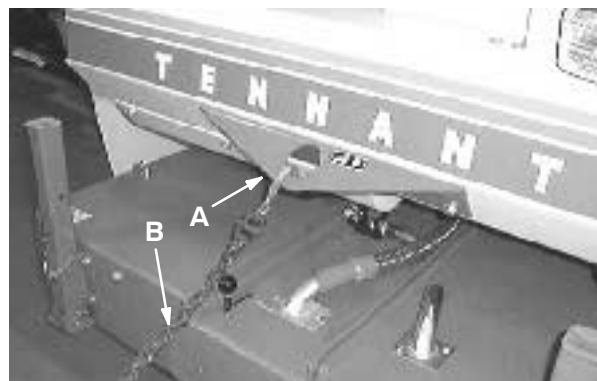

ATTACH WINCHING CHAIN

- A. Towing Bracket**
- B. Winching Chain**

OPERATION

- Turn the bypass valve 90° from the normal position before winching the machine onto the truck or trailer. See *TOWING THE MACHINE* section of this manual. Make sure the machine is centered.

FOR SAFETY: When loading machine onto truck or trailer, use winch. Do not drive the machine onto the truck or trailer unless the loading surface is horizontal AND is 380 mm (15 in) or less from the ground.

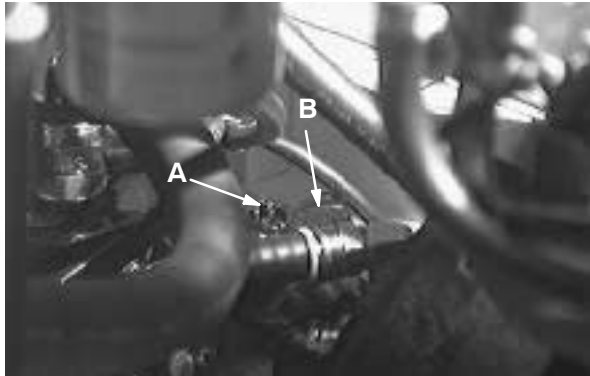

BYPASS VALVE

- A. Bypass Valve
- B. Propelling Pump

- Turn the machine so the pivot lock holes line up, then insert the pin in the lined up holes. The pin will prevent the machine from pivoting and creating a pinch area. See *PIVOT LOCK PIN* section of this manual.

WARNING: Crush Hazard Between Front And Rear Halves Of Machine. Engage Pivot Lock.

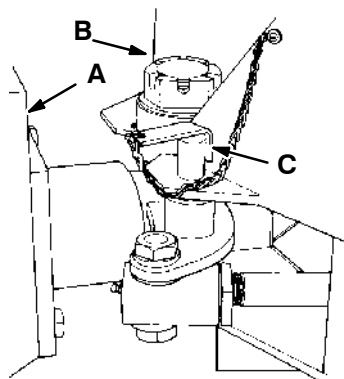

PIVOT LOCK PIN IN USE

- A. Machine Trailer Section
- B. Machine Tractor Section
- C. Pivot Lock Pin

- Position the machine onto the truck or trailer as far as possible. If the machine starts to veer off the centerline of the truck or trailer, stop and turn the steering wheel to center the machine.
- Set the parking brake, lower the scrub head and block the machine tires. Tie down the machine to the truck or trailer at the six tie down locations before transporting.
- Tie the front of the machine at the two corners of the front frame.



FRONT TIE DOWN LOCATION

- A. Front Tie Down Holes

- Tie the middle of the machine on the tie down bracket on the rear of the tractor frame.

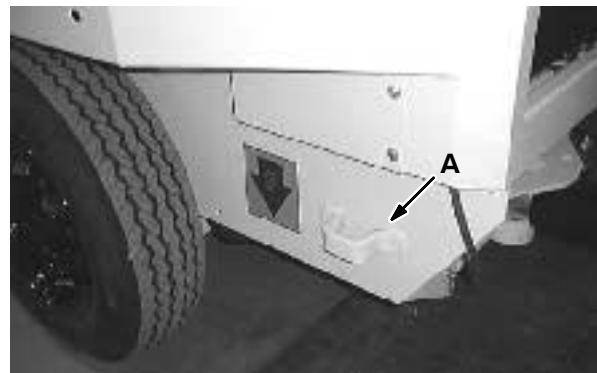

MIDDLE TIE DOWN LOCATION

- A. Middle Tie Down Bracket

00251

- Tie the rear of the machine under the rear bumper at the two bumper mounts.



REAR TIE DOWN LOCATION

A. Rear Bumper Mounts

- If the machine is equipped with the optional scrub head support legs, pull the pins to lower the legs. Lock them into position again by replacing the pins.

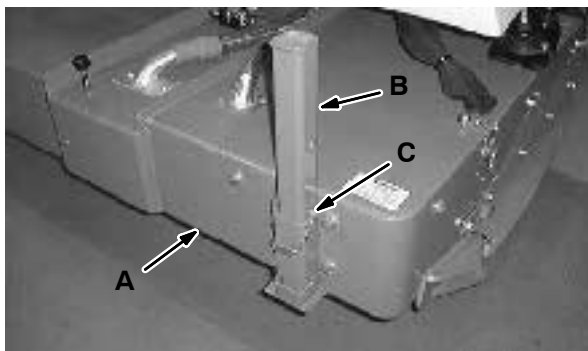

OPTIONAL SCRUB HEAD SUPPORT LEG

- A. Scrub Head**
- B. Support Leg**
- C. Pin**

- If the loading surface is not horizontal or is higher than 380 mm (15 in) from the ground, use a winch to unload machine.

If the loading surface is horizontal AND is 380 mm (15 in) or less from the ground, the machine may be driven off the truck or trailer.

FOR SAFETY: When unloading machine off truck or trailer, use winch. Do not drive the machine off the truck or trailer unless the loading surface is horizontal AND 380 mm (15 in) or less from the ground.

MACHINE JACKING LOCATIONS

Empty the recovery and solution tanks before jacking the machine. The machine jacking locations are labeled with a label. The tractor jacking locations are behind each of the front wheels, and the tank jacking locations are in front of the rear wheels.

FOR SAFETY: When Servicing Machine, Block Machine Tires Before Jacking Machine Up. Jack Machine Up At Designated Locations Only. Block Machine Up With Jack Stands. Use A Hoist Or Jack That Will Support The Weight Of The Machine.

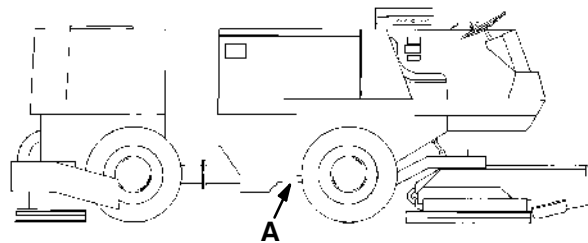

TRACTOR JACKING LOCATION

00362

A. Jacking Location

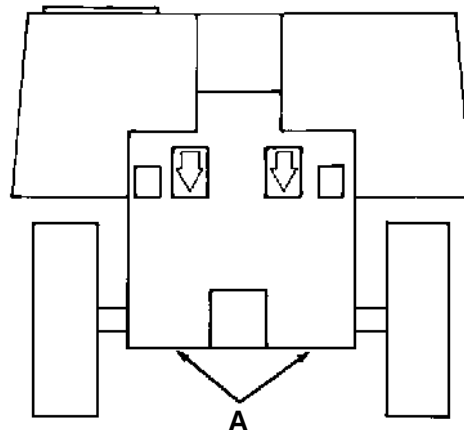

TANK JACKING LOCATION

01820

A. Jacking Location

MACHINE STORAGE

STORING MACHINE

When storing the machine for extended periods of time, the following procedures must be followed to reduce the chance of rust, sludge, and other undesirable deposits to form:

1. Drain and clean out the solution recovery and cleaning solution tanks.
2. Park the machine in a cool and dry area.
3. Stop the engine and set the machine parking brake.
4. Raise and lock the scrub head.
5. Fill the hydraulic reservoir with hydraulic fluid to the full mark on the dipstick, to prevent excessive condensation from forming in the reservoir.

NOTE: Before preparing the engine for storage, allow it to cool down to the surrounding temperature. Oil adheres to cold metal surfaces much better than hot surfaces.

DIESEL POWERED MACHINES

To store the machine for 30 days or more:

1. Change the engine oil and filter.
2. Drain all fuel from the fuel tank and the fuel filters. Pour 1 gal (4 L) of new, clean #1 diesel fuel in tank.
3. Prime the fuel system.
4. Seal the air vent in the fuel tank or filler cap with waterproof tape.
5. Drain engine coolant.

6. Remove the injectors and pour a small amount of pure castor oil into the cylinder bores.
7. Replace the injectors (using new copper sealing washers) and slowly rotate the crankshaft one complete revolution to evenly distribute the lubricant. Do not rotate crankshaft further so as not to destroy protective film on bore walls.
8. Remove the engine air filter and carefully seal the intake orifice with waterproof tape or some other suitable medium.
9. Remove the exhaust pipe and seal the manifold outlet.
10. Remove valve rocker cover. Lubricate the rocker gear with engine oil and replace the cover. Be sure that the gasket is correctly fitted.
11. Clean the engine breather pipe. Seal the end with waterproof tape or a cork.
12. Remove all of the belts from the engine and save for future use. Attach them to the engine to prevent loss.

RECOMMENDED FIRST 50-HOUR MACHINE INSPECTION

After the first 50 hours of operation, the following procedures are recommended:

1. Check the air filter element. Tighten all connections on intake hose, air filter, etc.
2. Change engine oil and filter.
3. Check for the correct alternator and vacuum fan belt tension.
4. Check the scrub brush pattern.
5. Check the scrub head side squeegee blades for wear or damage.
6. Check the rear squeegee for worn or damaged blades or for incorrect adjustment.
7. Check vacuum hoses for damage or loose connections.
8. Check engine valve tappet clearance.
9. Diesel powered machines: Remove the rocker assembly and tighten the cylinder head nuts in the correct sequence and to the correct torque.
10. Torque the cylinder head bolts to the proper specification.
11. Perform all remaining 50-hour lubrication and maintenance procedures listed in the *MAINTENANCE CHART*.

MAINTENANCE CHART

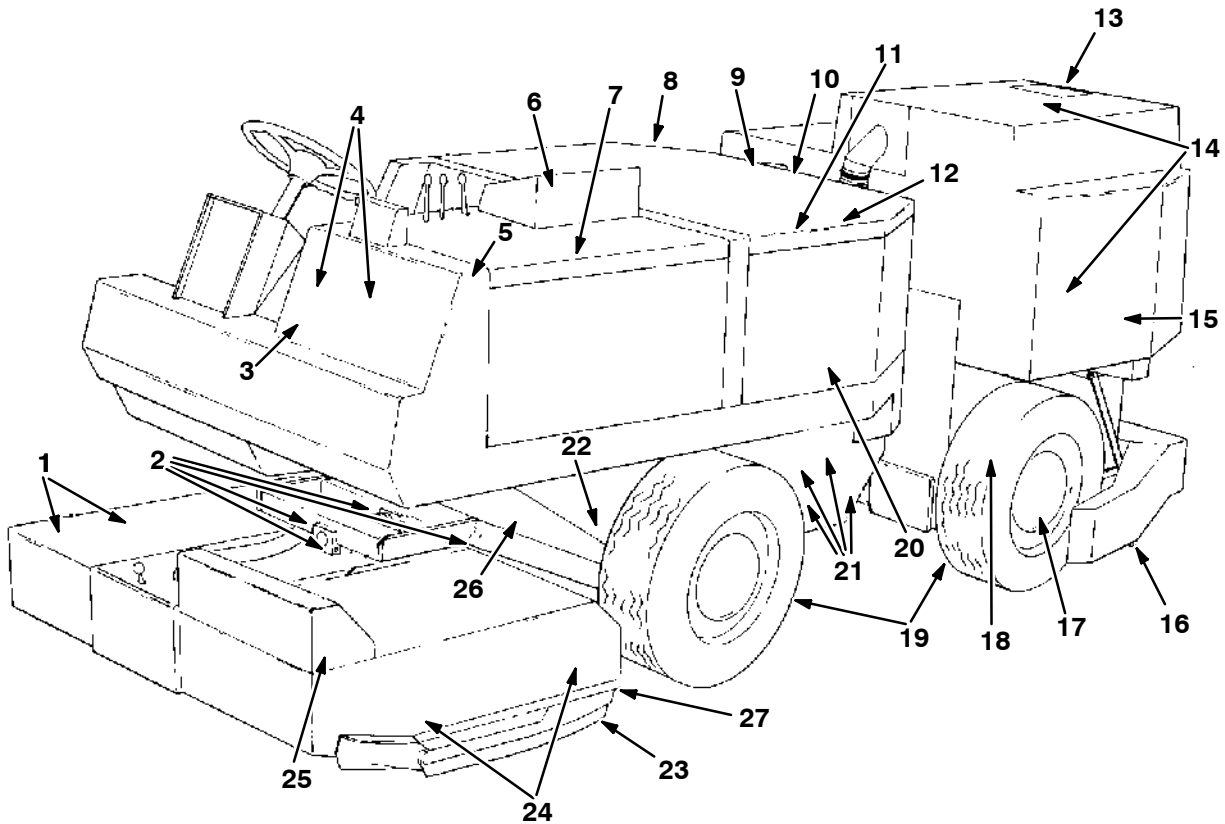

00291

Interval	Key	Description	Procedure	Lubricant/ Fluid	No. of Service Points
Daily	7	Engine air filter	Check service indicator	-	1
	11	Engine crankcase	Check oil level	EO	1
	11	Water trap, diesel	Check and drain	-	1
	16	Rear squeegee	Check for damage, wear, and adjustment	-	1
	23	Side squeegees	Check for damage, wear, and adjustment	-	2
	27	Scrub head rear squeegees	Check for damage, wear, and adjustment	-	2
	24	Scrub brushes	Check for damage, wear, and adjustment	-	2
	19	Tires	Check air pressure	-	4
	13	SRS Solution tank and metering pump	Empty and clean Flush laminar tubes	-	1
50 Hours	11	Engine crankcase	Change oil and oil filter element	EO	1
	24	Scrub brushes	Rotate brushes	-	2
	21	Machine pivot	Lubricate	SPC	4
	2	Scrub head pivot	Lubricate	SPC	4
	22	Scrub head hinges	Lubricate	SPC	2
	18	Rear squeegee casters	Lubricate	SPC	3
	1	Scrub brush idler plugs	Lubricate	SPC	2
	6	Vacuum fan shaft	Lubricate	SPC	1

Interval	Key	Description	Procedure	Lubricant/ Fluid	No. of Service Points
50 Hours	10	Radiator	Clean exterior	-	1
	25	Solution dispensing tube	Flush	-	1
	8	Vacuum fan drive belt	Check tension	-	1
100 Hours	11	Water trap	Clean	-	1
	8	Intermediate drive belt	Check tension	-	1
	12	Alternator belt	Check tension	-	1
	5	Hydraulic fluid reservoir	Check fluid level	HYDO	1
	10	Radiator	Check coolant level	WG	1
200 Hours	26	Parking brake	Check adjustment	-	1
	14	Spray deflectors	Check for wear	-	2
	19	Wheels	Tighten lug nuts	-	4
400 Hours	3	Brake master cylinder	Check fluid level	BF	1
	11	Engine	Adjust valve tappets	-	8
	11	In-line fuel filter	Replace filter elements	-	1
	11	Fuel filter	Replace filter elements	-	2
	11	Water trap filter	Replace filter element	-	1
800 Hours	5	Hydraulic reservoir breather	Replace	-	1
	10	Cooling system	Flush	-	1
1200 Hours	4	Hydraulic fluid filter	* Change filter element	-	1
2000 Hours	17	Rear wheel bearings	Repack with lubricant	WBG	2
2400 Hours	5	Hydraulic fluid reservoir	* Replace suction strainer	-	1
			* Change hydraulic fluid	HYDO	1

NOTE: Change the hydraulic fluid, filter, and suction strainer, indicated (), after every 800 hours for machines NOT originally equipped with **TennantTrue** premium hydraulic fluid. (See Hydraulics section).*

BF - Brake fluid

EO - 10W-30, 10W-40 or 15W-40 Engine oil, API diesel classification CF or better

HYDO - **TennantTrue** premium hydraulic fluid or equivalent

SPC - Special lubricant, Lubriplate EMB grease, TENNANT Part No. 01433-1

WBG - Wheel bearing grease

WG - Water and permanent-type ethylene glycol antifreeze, one-to-one ratio

NOTE: More frequent intervals may be required in extremely dusty conditions.

LUBRICATION

ENGINE

Check the engine oil level daily.

Change the engine oil and oil filter after every 50 hours of operation. Change the engine oil more frequently if the environment is extremely dusty.

The following oil grades are recommended for engines operating in the ambient temperatures listed.

SINGLE AND MULTI-VISCOSITY OILS		
Below 32° F (Below 0° C)	32° to 77° F (0° to 25° C)	Above 77° F (Above 25° C)
10W	20	30
10W 30		

The engine oil capacity for the diesel Continental TMD27 engine (machines below serial number 006409) is 7 qt (6.6 L) with filter.

The engine oil capacity for the diesel Perkins engine (machines serial number 006409-007002) is 11 qt (10.4 L) with filter.

The engine oil capacity for the Cat engine is (machines serial number 007003 and above) 10.6 qt (10.0 L) with filter.

VACUUM FAN SHAFT

There is one grease fitting which is used to lubricate the vacuum fan shaft. Grease the vacuum fan bearings after every 50 hours of operation. The vacuum fan grease fitting is covered with a plastic cap. Snap the cap open and apply Lubriplate EMB grease (TENNANT Part No. 01433-1) to the vacuum fan grease fitting. Wipe off all excess grease and replace the grease fitting cap.

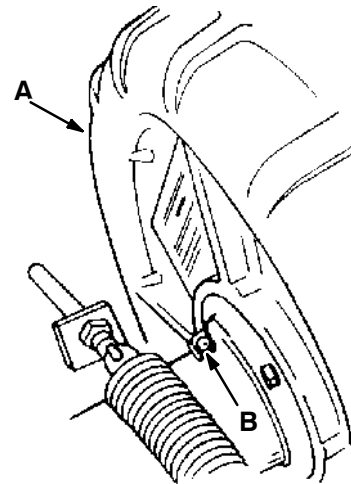

VACUUM FAN

03789

- A. Vacuum Fan**
- B. Grease Fitting**

MACHINE PIVOT

There are four grease fittings which are used to lubricate the machine pivot assembly. There is an upper bearing grease fitting, a lower bearing grease fitting, and a grease fitting on each rod end of the steering cylinder. Apply grease to these fittings after every 50 hours of operation. Use a Lubriplate EMB grease (TENNANT Part No. 01433-1).

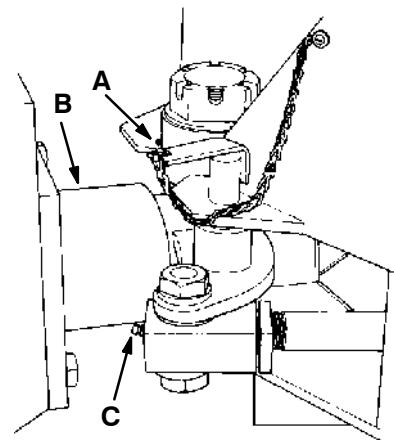

MACHINE PIVOT

00251

- A. Upper Bearing Grease Fitting**
- B. Machine Pivot**
- C. Steering Cylinder Rod End Grease Fitting**

SCRUB HEAD PIVOT

There are four grease fittings which are used to lubricate the scrub head pivot assembly—one on each of the four scrub head pivot blocks. Apply grease to these fittings after every 50 hours of operation. Use a Lubriplate EMB grease (TENNANT Part No. 01433-1).

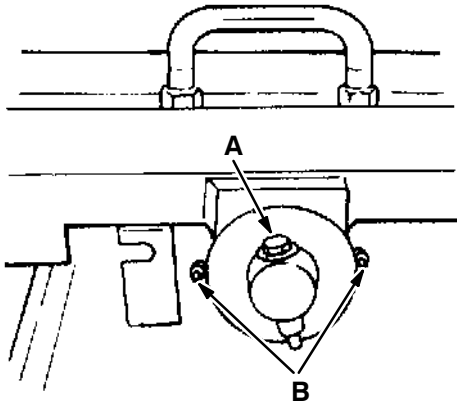

SCRUB HEAD PIVOT

03790

- A. Pivot
- B. Grease Fitting

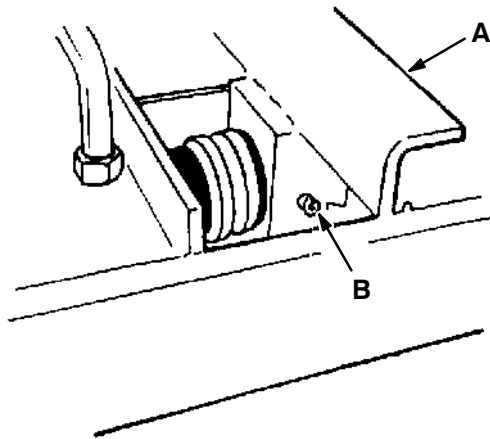

SCRUB HEAD PIVOT

03791

- A. Scrub Head
- B. Grease Fitting

SCRUB HEAD HINGES

There are two grease fitting which are used to lubricate the scrub head hinges. One grease fitting is located on the underside of each of the hinges. Apply grease to these fittings after every 50 hours of operation. Use a Lubriplate EMB grease (TENNANT Part No. 01433-1).

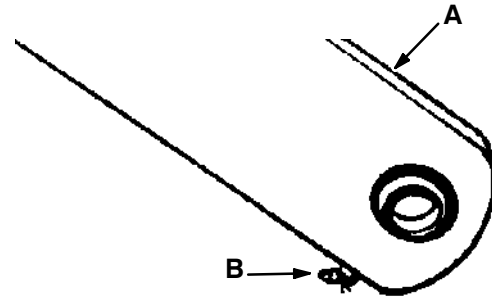

SCRUB HEAD HINGE

03792

- A. Scrub Head
- B. Grease Fitting

REAR SQUEEGEE CASTERS

Lubricate the rear squeegee casters after every 50 hours of operation. Use Lubriplate EMB grease (TENNANT Part No. 01433-1).

SCRUB BRUSH IDLER PLUGS

There are two grease fittings which are used to lubricate the brush idler plugs. They are located in the center of each idler plug and are covered with plastic caps. Snap the caps open to apply grease to the fittings. Use a Lubriplate EMB grease (TENNANT Part No. 01433-1). Wipe off all excess grease and replace the plastic cap. Apply grease to the fittings after every 50 hours of operation.

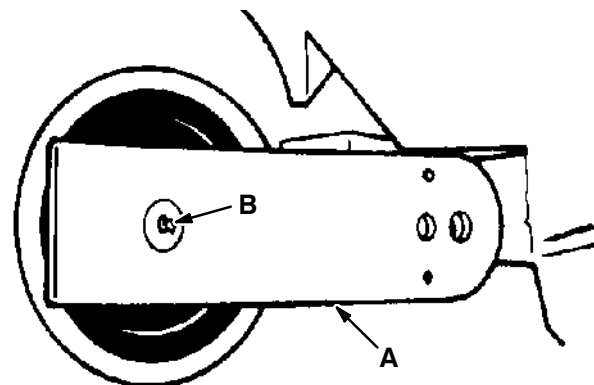

BRUSH IDLER PLUG

03793

- A. Idler Arm
- B. Grease Fitting

REAR WHEELS

The rear wheels have automotive-type bearings. Repack the bearings with automotive-type wheel bearing grease after every 2000 hours of operation.

HYDRAULICS

HYDRAULIC FLUID

The quality and condition of the hydraulic fluid plays a very important role in how well the machine operates. TENNANT's hydraulic fluid is designed to meet the special needs of its machines.

TENNANT's hydraulic fluids provide longer life of the hydraulic components. There are two fluids available for two different temperature ranges:

TennantTrue premium hydraulic fluid (Extended Life)			
Part number	Ambient temperature	ISO Grade	Capacity
1057710	above 7° C (45° F)	100	3.8 L (1 gal)
1057711	above 7° C (45° F)	100	19 L (5 gal)
1057707	below 7° C (45° F)	32	3.8 L (1 gal)
1057708	below 7° C (45° F)	32	19 L (5 gal)

The higher temperature fluid is designed with a higher viscosity and should not be used at the lower temperatures. Possible damage to the hydraulic pumps may occur because of improper lubrication.

The lower temperature fluid is a thinner fluid designed for colder temperatures.

If a locally-available hydraulic fluid is preferred, or if products of only one oil company are used, contact TENNANT Technical Customer Service to check the specifications of the substitute fluid. Using substitute fluids can cause premature failure of hydraulic components.

ATTENTION! Hydraulic components depend on system hydraulic fluid for internal lubrication. If dirt or other contaminants are allowed to enter the hydraulic system, malfunctions, accelerated wear, and damage will result.

HYDRAULIC FLUID RESERVOIR

Hydraulic fluid is stored in the hydraulic fluid reservoir. The reservoir holds up to 11.5 gal (44 L) of hydraulic fluid. The reservoir is located in the front left corner of the machine.

The reservoir is equipped with a breather-filler cap and fluid level dipstick mounted on the filler neck. See Hydraulic Fluid Reservoir Breather for breather service information.

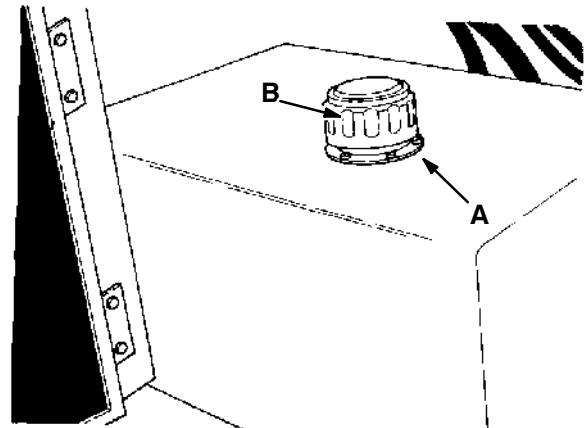

02354

HYDRAULIC FLUID RESERVOIR BREATHER-FILLER CAP

- A. Filler Neck
- B. Breather-Filler Cap

The hydraulic fluid level dipstick is built into the breather-filler cap. The end of the dipstick is marked with "full" and "add" levels. This indicates the level of hydraulic fluid in the reservoir.

Check the hydraulic fluid level after every 100 hours of operation. It should be above the “add” mark on the dipstick, but not above the “full” mark when the hydraulic fluid is at operating temperature.

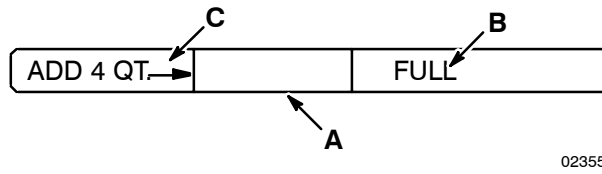

HYDRAULIC FLUID LEVEL DIPSTICK

- A. Dipstick**
- B. Full Range**
- C. Add Range**

Lubricate the filler cap gasket with a film of hydraulic fluid before putting the cap back on the reservoir.

Do not overfill the hydraulic fluid reservoir. The hydraulic fluid expands as it heats to its normal operating temperature. Always allow for expansion when filling the reservoir.

ATTENTION! Do not overfill the hydraulic fluid reservoir or operate the machine with a low level of hydraulic fluid in the reservoir. Damage to the machine hydraulic system may result.

Drain and refill the hydraulic fluid reservoir with new **TennantTrue** premium hydraulic fluid after every 2400 hours of operation. Machines have a blue colored drop (left photo) on the hydraulic fluid label if originally equipped with **TennantTrue** premium hydraulic fluid.



TennantTrue Fluid



Previous Fluid

*NOTE: Change the hydraulic fluid, filter, and suction strainer after every 800 hours for ALL machines that have NOT consistently used **TennantTrue** premium hydraulic fluid or equivalent.*

TO DRAIN THE HYDRAULIC FLUID RESERVOIR

1. Stop the engine and set the machine parking brake.

FOR SAFETY: Before Leaving Or Servicing Machine; Stop On Level Surface, Set Parking Brake, And Turn Off Machine.

2. Allow the hydraulic fluid to cool.
3. Open the left side access door.
4. Loosen the breather-filler cap. Remove the reservoir drain plug located on the bottom of the reservoir to drain the hydraulic fluid. Discard the used hydraulic fluid.

NOTE: Always change the hydraulic fluid filter when draining the hydraulic fluid reservoir.

5. Flush the reservoir with clean hydraulic fluid or suitable solvent. Do not use gasoline, kerosene, or diesel fuel.
6. Reinstall the reservoir drain plug and breather-filler cap.
7. Close the left side access door.

TO FILL THE HYDRAULIC FLUID RESERVOIR

1. Open the left side access doors.
2. Remove the breather-filler cap.
3. Pour the new hydraulic fluid into the hydraulic fluid reservoir through a 200 mesh screened funnel. Watch the hydraulic fluid level on the sight gauge. Do not overfill the reservoir.

MAINTENANCE

ATTENTION! Use only new-approved hydraulic fluid to fill the hydraulic fluid reservoir.

4. Check the hydraulic fluid level in the reservoir with the reservoir dipstick.
5. Add hydraulic fluid until the level in the reservoir is between the "ADD" and the "FULL" range. Do not overfill.

NOTE: Do not overfill the hydraulic fluid reservoir. As hydraulic fluid heats to its normal operating temperature, it expands. Always allow for this expansion when filling the hydraulic fluid reservoir.

6. Place the reservoir breather-filler cap securely on the reservoir.
7. Close the access doors.

The reservoir has a built-in strainer outlet that filters hydraulic fluid before it enters the system. Replace the strainer after every 2400 hours of operation.

HYDRAULIC FLUID RESERVOIR BREATHER

The hydraulic fluid reservoir is equipped with a breather. The breather is built into the filler cap on top of the reservoir. It maintains atmospheric pressure in the reservoir. The breather should be replaced after every 800 hours of operation.

HYDRAULIC FLUID FILTER

The hydraulic fluid filter is located in the engine compartment. Replace the filter element after every 1200 hours of operation or if the clogged hydraulic filter light remains on. Check the hydraulic fluid level and refill as needed.

TO REPLACE THE HYDRAULIC FLUID FILTER ELEMENT

1. Park the machine on a flat surface, stop the engine, and set the machine parking brake.

FOR SAFETY: Before Leaving Or Servicing Machine; Stop On Level Surface, Set Parking Brake, And Turn Off Machine.

2. Open the left side access doors.
3. Unthread and discard the hydraulic fluid filter elements.

NOTE: Discard all hydraulic fluid drained from the system. Drained hydraulic fluid may contain foreign material harmful to the hydraulic system.

4. Apply a thin coat of hydraulic fluid to the seal of the new hydraulic fluid filter element.
5. Thread and hand tighten the new hydraulic fluid filter elements on the filter heads.
6. Operate the machine and check for leaks. Correct any leaks found.
7. Check the hydraulic fluid reservoir level and fill as required.
8. Close the access doors.

HYDRAULIC FLUID LEAKS

Hydraulic fluid escaping at high pressure from a very small hole can be almost invisible and can cause serious injuries. Use a piece of cardboard or wood, rather than hands, to search for suspected leaks.

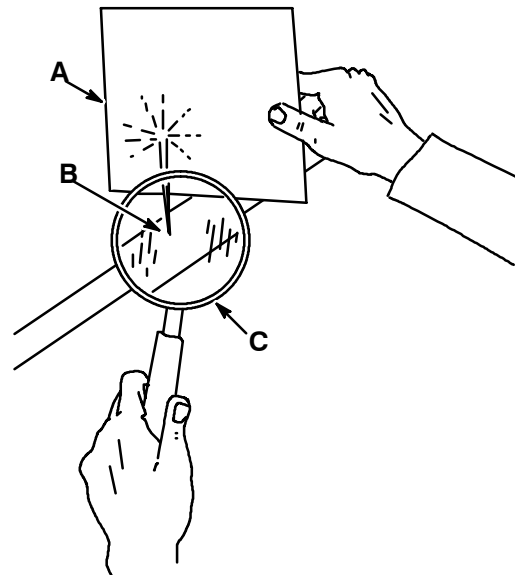

HYDRAULIC PIN HOLE LEAK

- A. Cardboard
- B. Pin Hole Leak
- C. Magnifying Glass

00002

If injured by escaping hydraulic fluid, see a doctor at once. Serious infection or reaction can develop if proper medical treatment is not administered immediately.

FOR SAFETY: When Servicing Machine, Use Cardboard To Locate Leaking Hydraulic Fluid Under Pressure.

**HYDRAULIC COMPONENTS
TROUBLESHOOTING**

Problem	Cause	Remedy
Hydraulic cylinder failure	Piston seals leaking	Install seal kit
	Barrel worn or rod bent	Replace cylinder
Hydraulic control valve failure	Valve seals leaking	Install seal kit
	Solenoid failure	Replace solenoid
	Solenoid spool sticking	Replace valve section
	Check valve sticking	Replace valve
	Relief valve stuck open (leaking)	Clean or replace relief valve
Hydraulic steering valve failure	Valve leaking	Install seal kit
	Drive link failure	Replace drive link
	Thrust bearing worn	Replace thrust bearing
	Gerotor worn	Replace gerotor set
Hydraulic motor failure	Motor leaking	Install seal kit
	Drive link failure	Replace drive link
	Gerotor worn	Replace gerotor set
	Output shaft failure	Replace output shaft and bearings
Hydraulic vane pump failure	Pump leaking	Install seal kit
	Vane set failure	Replace vane set
	Relief valve stuck	Replace relief valve
	Engine-to-pump coupling failure	Replace coupling
Hydraulic piston pump failure	Pump leaking	Install seal kit
	Relief valve stuck	Clean or replace relief valve
	Integral charge pump failure	Replace charge pump
	Rotating group worn	Replace rotating group
	Shaft failure	Replace shaft
	Backplate worn	Replace backplate
	Engine-to-pump coupling failure	Replace coupling

ENGINE

LUBRICATION

Check the engine oil level daily.

Change the engine oil and oil filter after every 50 hours of operation. Change the engine oil more frequently if the environment is extremely dusty.

The following oil grades are recommended for engines operating in the ambient temperatures listed.

SINGLE AND MULTI-VISCOSITY OILS		
Below 32° F (Below 0° C)	32° to 77° F (0° to 25° C)	Above 77° F (Above 25° C)
10W 10W 30	20	30

The engine oil capacity for the Continental TMD27 diesel engine (machines below serial number 006409) is 7 qt (6.6 L) with filter.

The engine oil capacity for the diesel Perkins engine (machines serial number 006409-007002) is 11 qt (10.4 L) with filter.

The engine oil capacity for the Cat diesel engine is (machines serial number 007003 and above) 10.6 qt (10.0 L) with filter.

COOLING SYSTEM

Maintaining cooling system efficiency is important. Engine temperatures must be brought up to and maintained within the satisfactory range for efficient operation. However, the engine must be kept from overheating in order to prevent damage to the valves, pistons, and bearings. Check the coolant level after every 100 hours of operation.

Use soft, clean water mixed with permanent-type, ethylene glycol antifreeze in a one-to-one ratio. Deposits of sludge, scale, and rust prevent normal heat transfer. Flush the radiator and the cooling system after every 800 hours of operation using a dependable cleaning compound. Follow the mixing procedure recommended by the compound manufacturer. This is important because of the difference in concentration and composition of the cleaning compounds. After cleaning, flush the system with clean water.

Whenever a cooling system is badly rust-clogged as indicated by overflow loss or abnormally high operating temperatures, corrective cleaning by reverse flow flushing will most effectively remove the heavy deposits of sludge, rust, and scale. The reverse flow flushing should be performed immediately after draining the cleaning solution. Flush the radiator first, then the engine, to allow the engine to cool as much as possible.

Engine overheating may also be caused by dirty radiator fins. The exterior fins of the radiator can be cleaned with an air hose. Clean the radiator exterior after every 50 hours of operation.

Blow all dust, which may have collected on the radiator, in through the grill and radiator fins, opposite the direction of normal air flow. This should be done only after the radiator has cooled, to avoid cracking.

FOR SAFETY: When Servicing Machine, Wear Eye And Ear Protection When Using Pressurized Air Or Water.

The engine is equipped with a 180° F (82° C) thermostat. Normal engine temperature is 200° F (93° C). Temperatures up to 220° F (104° C) are allowable. Temperatures over 220° F (104° C) indicate a problem exists.

NOTE: Overheating is always accompanied by loss of coolant water. If in doubt, check.

A pressure cap is used on the radiator to prevent overflow loss of water during normal operation. The spring-loaded valve in the cap closes the outlet to the overflow pipe of the radiator and thus seals the system. Pressure developing within the system raises the boiling point of the coolant and allows higher temperatures without overflow loss from boiling. The pressure valve opens at 15 psi (100 kPa) allowing steam and water to pass out the overflow pipe.

FOR SAFETY: When Servicing Machine, Avoid Contact With Hot Engine Coolant.

AIR INTAKE SYSTEM

The importance of maintaining an air filter cannot be overemphasized. Dirt ingested through improperly installed, improperly serviced, or inadequate air filter elements wears out more engines than long hours of operation. Even a small amount of dirt will wear out a set of piston rings in just a few hours. Operating with a clogged air filter element also causes the fuel mixture to be richer, which can lead to formation of harmful sludge deposits in the engine. Always cover the air intake when the air filter is removed for servicing. Do not neglect servicing the air filter. Use only approved replacement parts. Keep all other air intake components such as hoses and clamps secure and in good condition to prevent entrance of unfiltered air.

Over maintenance can cause more damage than good. Removing the air filter element more often than is needed allows contaminants to enter the engine unnecessarily. Replace the air filter element only when the restriction indicator indicates excessive restriction in the system.

AIR FILTER SERVICE INDICATOR

The air filter service indicator signals when to replace the air filter element. Check the service indicator daily. The red line will move on the scale as the air filter element fills with dirt. Do not replace the air filter element until the red line reaches 20 in H₂O (5 kPa) and the "Service when Red" window is filled with red. The service indicator red line may return to a lower reading on the scale when the engine is shut off. The red line will return to a correct reading when the engine is started.

Replace the filter element when the service indicator reads 20 in H₂O (5 kPa). After replacing the air filter element, reset the service indicator by pushing the reset button on the end of the indicator.

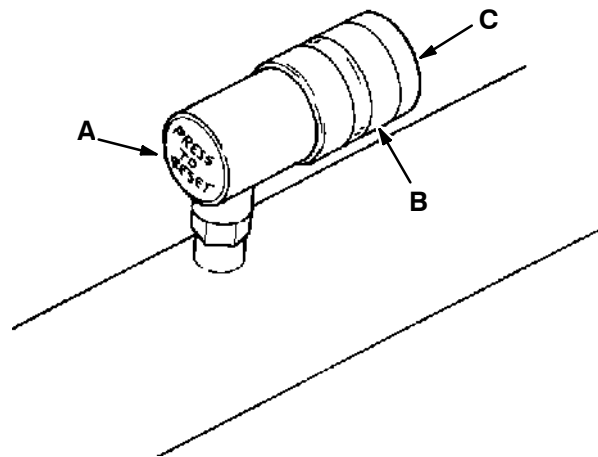

AIR FILTER RESTRICTION INDICATOR

00212

- A. Indicator Reset Button**
- B. Indicator Window**
- C. Restriction Indicator**

AIR FILTER

The engine air filter housing includes a dust cap and a dry cartridge-type air filter element. The dust cap must be emptied of dirt daily. The air filter element must be inspected or replaced whenever the air filter service indicator reads 20 in H₂O (5 kPa). The filter element must be replaced if it is damaged.

Service the air filter element only when the air filter service indicator shows excessive restriction in the system. Do not remove the air filter element unless it is restricting air flow.

MAINTENANCE

TO REPLACE AIR FILTER ELEMENT - CONTINENTAL ENGINES (For machines below serial number 006409)

1. Stop the engine and set the machine parking brake.

FOR SAFETY: Before Leaving Or Servicing Machine; Stop On Level Surface, Set Parking Brake, And Turn Off Machine.

2. Open the left side and top engine access doors.
3. Unscrew the clamp ring on the filter.
4. Remove the dust cap.
5. Empty the dust cap.
6. Remove the filter wing nut.
7. Gently pull the filter element out of the filter housing.

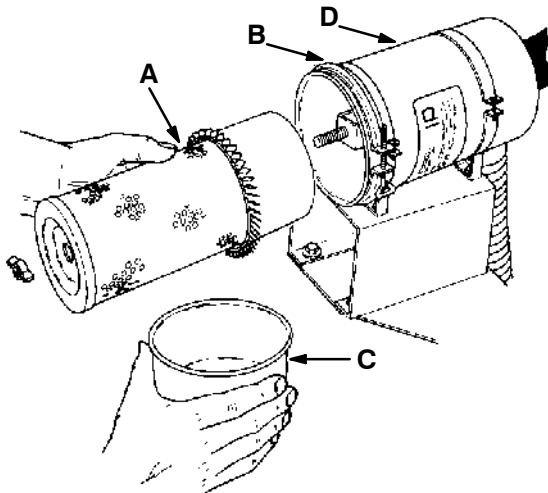

REMOVING AIR FILTER ELEMENT

00044

- A. Filter Element
- B. Clamp Ring
- C. Dust Cap
- D. Filter Housing

8. Clean the interior of the air cleaner housing with a damp cloth. Clean the element housing sealing surfaces.

9. Install the new filter element so the fins on the element are at the intake end of the air cleaner. Use care so the fins are not damaged. Tighten the wing nut attaching the element.
10. Install the dust cap with the arrows pointing up. Tighten the clamp ring to hold it in place. Check all intake hose connections for leaks or abrasion.

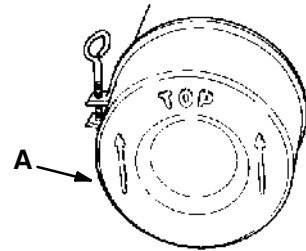

DUST CAP

02492

A. Dust Cap

11. Reset the air filter service indicator.
12. Close the access doors.

TO REPLACE AIR FILTER ELEMENT - PERKINS OR CAT ENGINES (For machines serial number 006409 and above)

1. Stop the engine and set the machine parking brake.

FOR SAFETY: Before Leaving Or Servicing Machine; Stop On Level Surface, Set Parking Brake, And Turn Off Machine.

2. Open the left side and top engine access doors.
3. Unlock the side clamps on the filter.
4. Remove the dust cap.
5. Empty the dust cap.
7. Gently pull the filter element out of the filter housing.

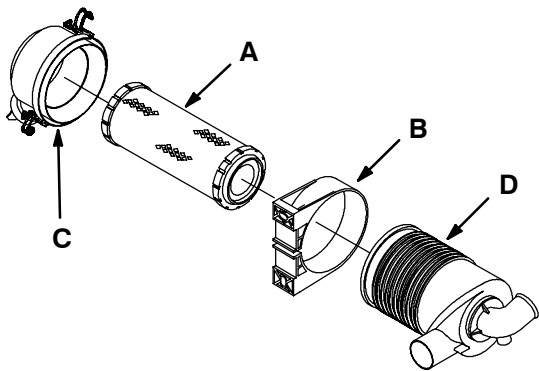

353633

REMOVING AIR FILTER ELEMENT

- A. Filter Element**
- B. Mounting Clamp**
- C. Dust Cap**
- D. Filter Housing**

8. Clean the interior of the air cleaner housing with a damp cloth. Clean the element housing sealing surfaces.

9. Install the new filter element so the open end of the filter is pressed over the intake hose inside the filter housing.
10. (Machines serial number 007003 and above) have a heavy duty safety element inside the standard element. Replace this element, do not clean it, after the regular element has been damaged or changed three times.
11. Install the dust cap with the arrows pointing up and the rubber dust cap on the bottom. Lock the side clamps onto the filter to hold it in place. Check all intake hose connections for leaks or abrasion.

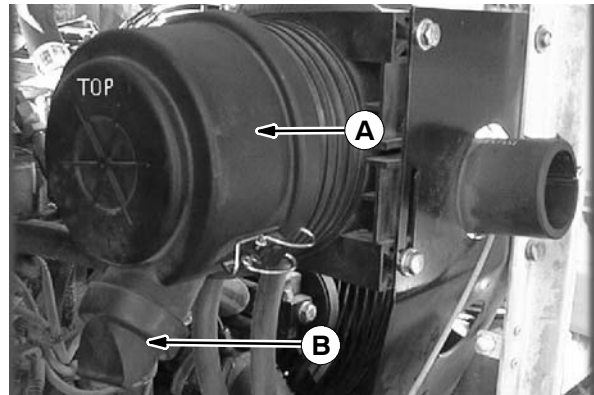

DUST CAP

- A. Dust Cap**
- B. Rubber Dust Cap**

12. Reset the air filter service indicator.
13. Close the access doors.

MAINTENANCE

FUEL SYSTEM

FUEL WATER TRAP

The fuel water trap is located next to the fuel tank. The water trap should be drained of water daily. To drain the water trap, unscrew the spigot on the bottom of the water trap. Drain the water trap of water. As fuel appears, tighten the spigot to stop the flow. It may be necessary to bleed the fuel system of air after draining the water trap.

After every 100 hours of operation, the water trap must be cleaned as described in *TO CLEAN THE WATER TRAP*. Replace the water trap filter element after every 400 hours of operation.

TO CLEAN WATER TRAP

1. Thoroughly clean the exterior of the water trap.
2. Unscrew the bowl retaining bolt in the center of the water trap head.
3. Lower the bowl from the water trap head. Replace the filter element if it is due to be replaced.
4. Thoroughly clean the water trap bowl in cleaning fluid.

NOTE: Do not use gasoline to clean the bowl.

5. After cleaning the water trap bowl, fill the bowl with clean fuel. Hold the water trap bowl in position under the water trap head.
6. Secure the bowl retaining bolt.

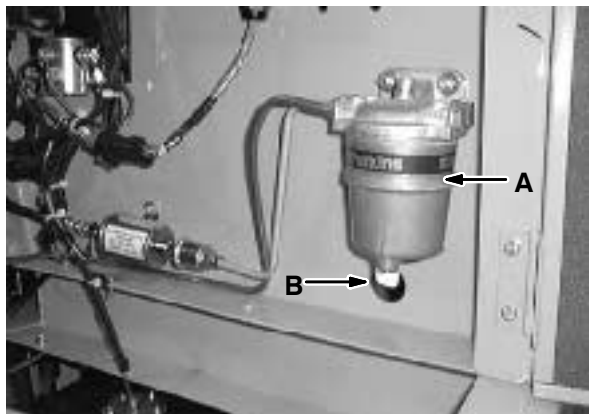

WATER TRAP - PERKINS ENGINES (For machines serial number 006409-007002)

- A. Water Trap
- B. Spigot

7. Prime the fuel system as described in *PRIMING THE FUEL SYSTEM*.

FUEL FILTER

The fuel filter is mounted on the top right side of the engine. The fuel filter should be replaced after every 400 hours of operation.

TO REPLACE FUEL FILTER - CONTINENTAL ENGINES (For machines below serial number 006409)

1. Thoroughly clean the exterior of the fuel filter assembly.
2. Release the two spring claps on either side of the metal canister element and pull the element off the filter bracket.

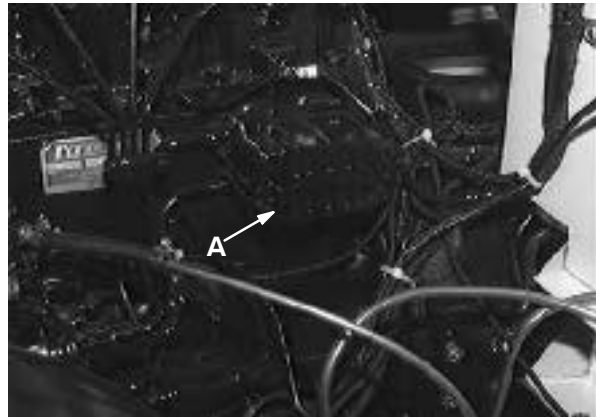

FUEL FILTER - CONTINENTAL ENGINES - (For machines below serial number 006409)

A. Fuel Filter Element

3. Lubricate the new element grommets with clean diesel fuel, and push the element into place. Snap the spring clamps into position.

After the fuel filter element has been changed, it is necessary to remove air from the fuel system. See *PRIMING THE FUEL SYSTEM*.

TO REPLACE FUEL FILTER - PERKINS ENGINES (For machines serial number 006409-007002)

1. Thoroughly clean the exterior of the fuel filter assembly.
2. Unscrew the filter bolt in the center of the head.

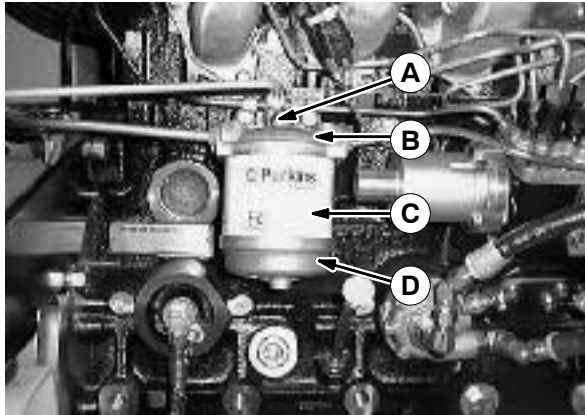

FUEL FILTER - PERKINS ENGINES - (For machines serial number 006409-007002)

- A. Filter Bolt**
- B. Filter Head**
- C. Filter Element**
- D. Filter Bowl**

3. Lower the filter bowl and element and discard the fuel, together with the old element.
4. Thoroughly clean the filter bowl in cleaning fluid.

NOTE: Do not use gasoline as a cleaning fluid.

5. Place the new element and sealing rings in position, fill with clean fuel, and push the filter bowl up firmly and squarely so that the top rim of the filter element locates centrally against the sealing ring in the filter head.
6. Hold in this position while the filter bolt is located and tightened. If the bowl is located correctly, no excessive tightening will be required to obtain a leak-proof seal.

After the fuel filter has been reassembled, it is necessary to remove air from the fuel system. See *PRIMING THE FUEL SYSTEM*.

WATER SEPARATOR/FUEL FILTER - CAT ENGINES (For machines serial number 007003 and above)

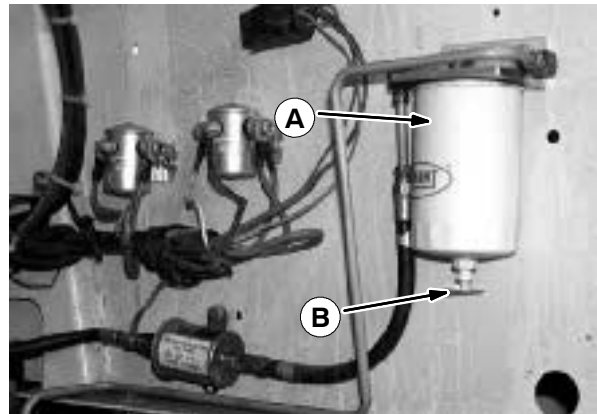

WATER SEPARATOR/FUEL FILTER - CAT ENGINES - (For machines serial number 007003 and above)

- A. Water Separator/Fuel Filter**
- B. Drain Cock**

The water separator/fuel filter filters impurities from the fuel and separates any water from the fuel system. It is located on the right side of the engine compartment. Water can be drained from the drain cock at the bottom as needed.

Replace the water separator/fuel filter element every 400 hours of operation.

MAINTENANCE

IN-LINE FUEL FILTER - PERKINS ENGINES (For machines serial number 006409-007002)

The in-line fuel filter is located on the end of the fuel pump, between the fuel pump and the fuel line leading to the water trap. Replace the fuel filter every 400 hours of operation.

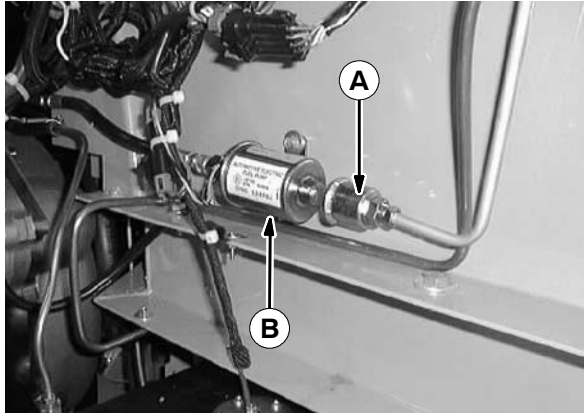

**IN-LINE FUEL FILTER - PERKINS ENGINES
(For machines serial number 006409-007002)**

- A. In-Line Fuel Filter**
- B. Fuel Pump**

FUEL INJECTION PUMP

The fuel injection pump controls the engine speed. The maximum speed screw is set and sealed by the manufacturer and must not be altered in any way unless factory authority is first obtained. Any adjustments should be carried out by experienced fuel pump technicians. The unauthorized removal of any seals on the pump may void the warranty.

NOTE: Unless proper test equipment and trained technicians are available, adjustment or maintenance of the fuel injection pump should not be attempted.

FUEL INJECTORS

When replacing injectors in the cylinder head, it is essential that a new, correct-type heat shield washer be fitted between the nozzle cap and the cylinder head.

Use care when replacing the fuel injectors to prevent loosening the injector leak-off nipples.

Be sure to cut a relief in the inside of your socket for clearance. This will prevent an interference between the socket and the leak-off nipple.

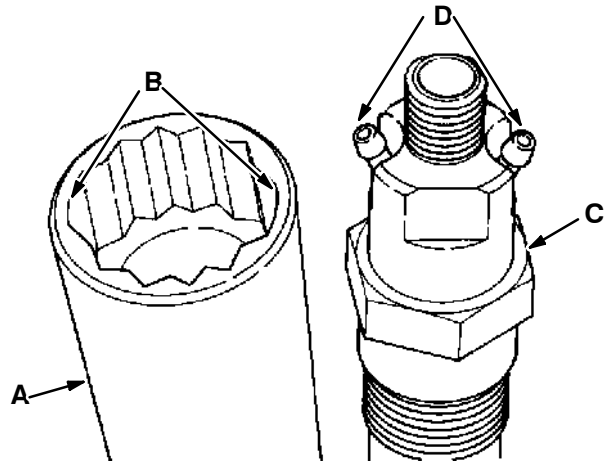

SOCKET RELIEF CLEARANCE

01477

- A. Socket**
- B. Relief**
- C. Injector**
- D. Leak-Off Nipple**

Tighten injectors evenly to 52 ft lb (70 Nm).

Injectors should be taken out only if engine is malfunctioning as outlined below:

- Misfiring
- Knocking in one (or more) cylinders
- Engine overheating
- Loss of power
- Smoky exhaust (black or white)
- Increased fuel consumption

The faulty injector or injectors may be located by loosening the line fitting nut on each, in turn, with the engine running at a fast idle. This allows the fuel to escape and not enter the cylinder. The injector least affecting the engine performance should be removed from the cylinder head and reconditioned or replaced.

NOTE: No attempt should be made to adjust the injection pressure without a proper testing pump and pressure gauge. It is impossible to adjust the setting of the injector with any degree of accuracy without proper equipment.

PRIMING THE FUEL SYSTEM - CONTINENTAL ENGINES (For machines below serial number 006409)

Priming is necessary on initial installation of the fuel injection system, after any subsequent removal, or if the system was drained by running out of fuel.

Before priming and venting, ensure that the outside of the vent screws and surrounding area is thoroughly clean to prevent dirt and foreign matter entering the system.

NOTE: Electrical equipment such as starters should be shielded during priming to prevent fuel entry.

1. Turn the ignition switch to the "on" position.
2. Loosen the filter outlet connection to the fuel injection pump inlet connection, whichever is higher, and allow the fuel to flow until free of air. Tighten the connection.

NOTE: If the filter outlet connection can not be reached due to the type of filter being used, loosen the fuel injection pump inlet connection.

3. Loosen any two injector high pressure pipe nuts at the injector end. Set the accelerator to the fully "open" position and ensure that the stop control is in the "run" position. Crank engine until fuel is free of air bubbles. Tighten nuts.

NOTE: The bleeding operation may take a considerable amount of cranking with the starter to purge all air. It is important that the battery be in good operating condition when bleeding.

If the engine will not start after bleeding, or any other time, it may be an indication of a low battery charge. If the voltage to the fuel shutoff solenoid falls below 8 volts, the valve will shut off fuel to the engine. This may happen during cranking if the battery charge is low. The condition may not be readily apparent since cranking speed might still be good.

4. Start the engine.

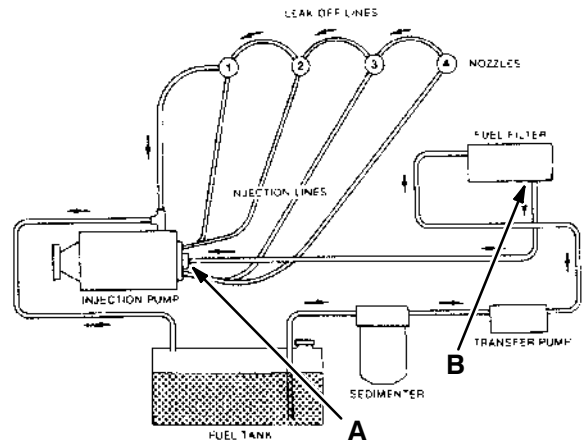

FUEL SYSTEM SCHEMATIC

- A. Fuel Injection Pump Inlet Connection**
- B. Filter Outlet Connection**

PRIMING THE FUEL SYSTEM - PERKINS ENGINES (For machines serial number 006409-007002)

Priming is necessary on initial installation of the fuel injection system, after any subsequent removal, or if the system was drained by running out of fuel.

Before priming and venting, ensure that the outside of the vent screws and surrounding area is thoroughly clean to prevent dirt and foreign matter entering the system.

1. Stop the engine and set the machine parking brake.

FOR SAFETY: Before Leaving Or Servicing Machine; Stop On Level Surface, Set Parking Brake, And Turn Off Machine.

2. Fill the fuel tank.
3. Open the side and top engine access doors.
4. Loosen the vent screw on the top of the fuel filter.

5. Turn the ignition switch on.
6. Allow the fuel pump to operate until fuel, free from air, comes through the filter vent point.

FOR SAFETY: When servicing machine, keep flames and sparks away from fuel system service area. Keep area well ventilated.

7. Tighten the filter vent screw.
8. Loosen all four of the high pressure fuel line connections at the atomizers.
9. Operate the starter motor until fuel, free from air, comes from the line connections.
10. Tighten the high pressure fuel line connections. The engine is now ready to start.
11. Close the access doors.

NOTE: The bleeding operation may take a considerable amount of cranking with the starter to purge all air. It is important that the battery be in good operating condition when bleeding.

If the engine will not start after bleeding, or any other time, it may be an indication of a low battery charge. If the voltage to the fuel shutoff solenoid falls below 8 volts, the valve will shut off fuel to the engine. This may happen during cranking if the battery charge is low. The condition may not be readily apparent since cranking speed might still be good.

NOTE: If the engine runs correctly for a short time and then stops, or runs roughly, check for air in the fuel system. If there is air in the system, there is probably a leak in the low pressure system.

11. Turn the ignition switch off.

CYLINDER HEAD

CYLINDER HEAD BOLT TIGHTENING – CONTINENTAL ENGINES

(For machines below serial number 006409)

The proper sequence and torque values should be used when reassembling the cylinder head. The cylinder head bolts must be tightened in the proper sequence after the first 50 hours of operation.

Hand torque cold M10 bolts to 50 to 55 ft lb (70 to 75 Nm) and M12 bolts to 90 to 95 ft lb (120 to 130 Nm) in the correct order.

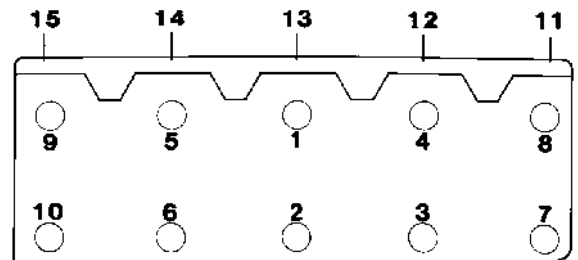

01472

CYLINDER HEAD BOLT TIGHTENING SEQUENCE

The cylinder head cap screws and risers must be retorqued after the engine is put into operation and brought up to proper operating temperatures. To retorque cap screws, follow the correct sequence. Loosen one head cap screw or riser at a time one quarter turn (90 degrees); then retorque it to the correct value. Check the valve tappet clearance.

NOTE: Power wrench torque limit must be held at least 10 ft lb (15 Nm) below hand torque specification; then hand torque to the specifications.

CYLINDER HEAD BOLT TIGHTENING PERKINS ENGINES

(For machines serial number 006409–007002)

The proper sequence and torque values should be used when reassembling the cylinder head. The cylinder head bolts must be tightened in the proper sequence after the first 50 hours of operation and after every 400 hours of operation.

Gradually and evenly tighten the setscrews to 52 ft lb (70 Nm) in the correct order.

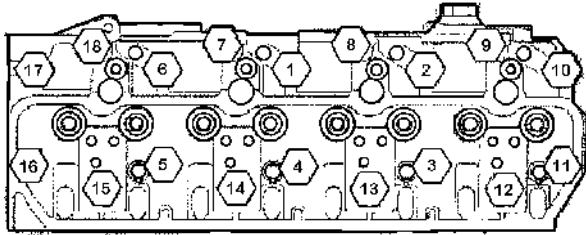

CYLINDER HEAD BOLT TIGHTENING SEQUENCE

Tighten the four additional setscrews with a 14mm extended socket spanner. Gradually and evenly tighten the four setscrews to 74 ft lb (100 Nm). Repeat the procedure to ensure that all setscrews are tightened to the correct torque.

NOTE: Power wrench torque limit must be held at least 10 ft lb (15 Nm) below hand torque specification; then hand torque to the specifications.

VALVE TAPPET CLEARANCE

The valve tappet clearance must be checked after the first 50 hours of operation and after every 400 hours of operation.

Check and adjust the intake valve tappets to 0.014 in (0.35 mm) clearance and the exhaust valve tappets to 0.018 in (0.45 mm) clearance when the engine is warm and is operating at idle speed.

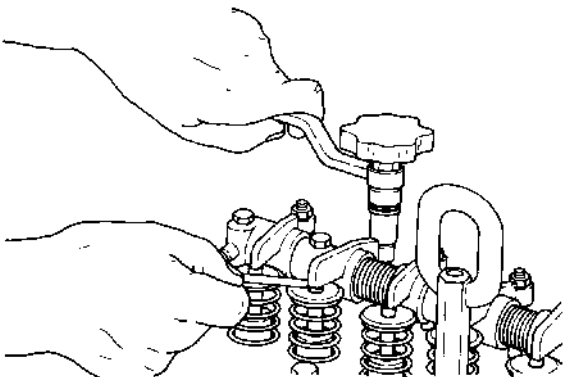

01473

ADJUSTING VALVE TAPPET CLEARANCE

ELECTRICAL SYSTEM**BATTERY**

The battery on diesel powered machines is rated at 12 V, 625 ccA. The battery is located in the engine compartment. When removing battery cables, remove the negative (-) cable before the positive (+) cable.

Do not allow the battery to remain in discharged condition for any length of time. Do not operate the machine if the battery is in poor condition or only 25% of the charge is left.

Clean the top surface and the terminals of the battery periodically. Use a strong solution of baking soda and water. Brush the solution sparingly over the battery top, terminals, and cable clamps. Do not allow any baking soda solution to enter the battery. Use a wire brush to clean the terminal posts and the cable connectors. After cleaning, apply a coating of clear petroleum jelly to the terminals and the cable connectors. Keep the top of the battery clean and dry.

Keep all metallic objects off the top of the battery, as they may cause a short circuit. Replace worn or damaged wires.

The electrolyte level in regular non-sealed batteries can be checked. The level must always be above the battery plates. Add distilled water to maintain solution at the correct level above the plates, but do not overfill. Never add acid to batteries, only water. Keep vent plugs firmly in place at all times, except when adding water or taking hydrometer readings.

FOR SAFETY: When Servicing Machine, Avoid Contact With Battery Acid.

If, when checking battery specific gravity, one or more battery cells tests lower than the other battery cells (0.050 or more), the cell is damaged, shorted, or is about to fail.

NOTE: Do not take readings immediately after adding water - if the water and acid are not thoroughly mixed, the readings may not be accurate. Check the hydrometer readings against this chart:

SPECIFIC GRAVITY at 80° F (27° C)	BATTERY CONDITION
1.260 - 1.280	100% charged
1.230 - 1.250	75% charged
1.200 - 1.220	50% charged
1.170 - 1.190	25% charged
1.110 - 1.160	Discharged

NOTE: If the readings are taken when the battery electrolyte is any temperature other than 80° F (27° C), the reading must be temperature corrected.

To determine the corrected specific gravity reading when the temperature of the battery electrolyte is other than 80° F (27° C):

Add to the specific gravity reading 0.004, 4 points, for each 10° F (5.5° C) above 80° F (27° C).

Subtract from the specific gravity reading 0.004, 4 points, for each 10° F (5.5° C) below 80° F (27° C).

BELTS AND CHAINS

VACUUM FAN DRIVE BELT

The vacuum fan drive belt tension should be checked after every 50 hours of operation. The proper belt tension for diesel machines is obtained when the midpoint of the belt deflects 8 to 9 lb (3.6 to 4.0 kg).

TO ADJUST VACUUM FAN DRIVE BELT

1. Stop the engine and set the machine parking brake.

FOR SAFETY: Before Leaving Or Servicing Machine; Stop On Level Surface, Set Parking Brake, And Turn Off Machine.

2. Raise the engine cover.

FOR SAFETY: When Servicing Machine, Avoid Moving Parts. Do Not Wear Loose Jackets, Shirts, Or Sleeves When Working On Machine.

3. Loosen the jam nuts on the tension spring eyebolt.
4. Thread the tension spring eyebolt in to tighten the vacuum fan drive belt or out to loosen the vacuum fan drive belt to get the desired belt tension.
5. Tighten the tension spring eyebolt jam nuts.
6. Lower the engine cover.

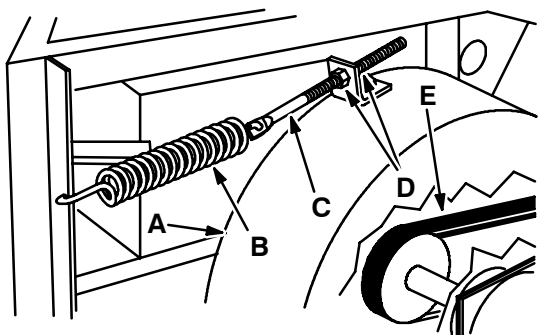

06973

ADJUSTING VACUUM FAN BELT

- A. Vacuum Fan Housing**
- B. Tension Spring**
- C. Tension Spring Eyebolt.**
- D. Jam Nut**
- E. Vacuum Fan Drive Belt**

ALTERNATOR AND RADIATOR FAN BELT

The alternator and radiator fan belt tension should be checked after every 100 hours of operation. The proper belt tension is obtained when the midpoint of the belt's longest span deflects 0.50 in (13 mm) from a force of 10 to 12 lb (5 to 6 kg).

TO ADJUST ALTERNATOR AND RADIATOR FAN BELT

1. Stop the engine and set the machine parking brake.

FOR SAFETY: Before Leaving Or Servicing Machine; Stop On Level Surface, Set Parking Brake, And Turn Off Machine.

2. Open the left rear engine access door.
3. Loosen the alternator clamp bolt.
4. Push the alternator out to tighten the belt.

ATTENTION! Do not use a pry bar against the alternator to tighten the belt. Using a pry bar may damage the alternator.

5. Tighten the alternator clamp bolt.
6. Check the belt deflection; adjust if necessary.
7. Close the left rear engine access door.

SCRUB HEAD

SCRUB HEAD

The scrub head houses the two scrub brushes and the brush drive mechanisms. The scrub head has two adjustments; scrub head height, and scrub brush pattern.

The scrub head height adjustment sets the minimum scrub head height. The height adjustment should not be changed unless, due to a major parts replacement or collision, the head adjustment may have been altered. If the head height is too low, excessive brush wear, engine overheating, brush bounce, or excessive brush drive plug and bearing wear may occur.

The scrub brush pattern adjustment determines the amount of contact the brush has with the floor. The brush pattern should be checked daily.

TO ADJUST SCRUB HEAD HEIGHT

1. The head height adjustment must be made with a full solution tank and tires correctly inflated; 55 psi (380 kPa) front, 35 psi (240 kPa) rear.

NOTE: Using a different sized tire on the machine, other than standard, will affect the head height adjustment.

2. The head height adjusting nut is located under the operator's seat. The nut is accessible by lifting up the seat. Hold the seat up by attaching its chain to the steering wheel.

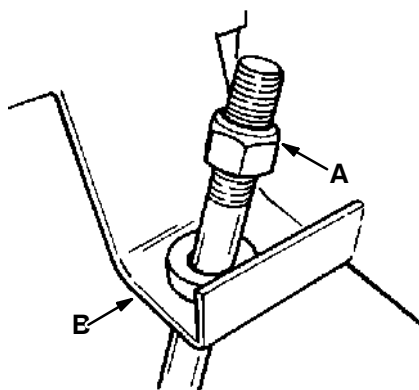

ADJUSTMENT NUT

- A. Nut**
- B. Scrub Head Link**

3. Adjust the nut so that the top front of the head is 13.62 in to 13.75 in (345 to 350 mm) from the floor.

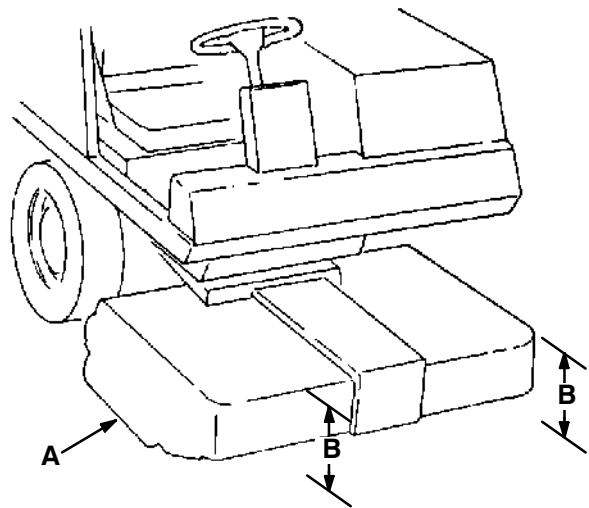

SCRUB HEAD ADJUSTMENT

- A. Scrub Head**
- B. 13.62 to 13.75 in (345 to 350 mm)**

4. If the scrub head is lower than 13.62 in (345 mm), washers should be added below the adjusting nut.

TO ADJUST SCRUB BRUSH PATTERN

1. The machine must have correct tire pressures, full solution tank, and correct scrub head height adjustment.
2. On a smooth, level floor, apply chalk or some other material that won't blow away easily.
3. With the scrub head raised, move the machine over the test area. Start the brush rotation, apply the foot brakes, and lower the scrubber head, allowing the brushes to spin in one spot for 15 to 20 seconds. With no chalk or other material on the floor, allow the brushes to spin approximately two minutes.
4. Polish marks made by both brushes should be visible. They should be about 1.5 in (40 mm) wide the full length of the brush. With a soft brush the polish mark should not exceed 3 in (75 mm) wide, evenly, the full length of the brush.

5. The rear brush polish mark is the most critical and should be adjusted first. If the polish mark is uneven or cone shaped from one end to the other, the brush leveling spring located at the operator side of the head lift, should be adjusted. The spring compensates for the weight of the brush drive motors. Loosen the top nut first to make the adjustment.

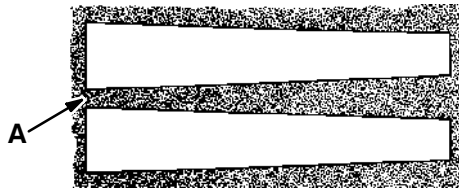

00082

TAPERED BRUSH PATTERN

A. Operator Side

Lower the brush leveling adjusting nut if the polish mark is too wide on the operator's side.

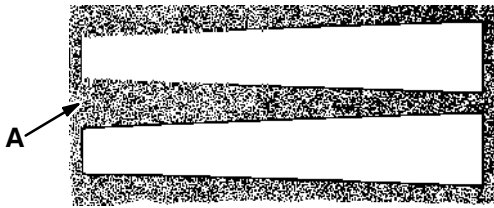

00082

TAPERED BRUSH PATTERN

A. Operator Side

Raise the brush leveling adjusting nut if the polish mark is too narrow on the operator's side. Retighten the top nut after making adjustments.

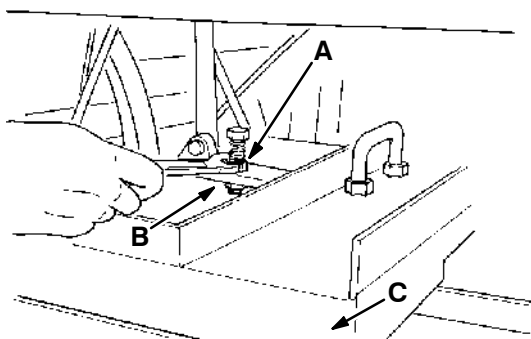

00285

LEVELING BRUSH

**A. Top Nut
B. Brush Leveling Adjusting Nut
C. Operator Side of Scrub Head**

6. The polish mark of the front brush should match the polish mark of the rear brush. If the front brush polish mark is uneven, the narrow side should be shimmed. Add shims to the shaft bearing mount located on the underside of the scrub head. Remove the debris trough, loosen the bolts holding the bearing protector, and loosen the flat socket head bolts that hold the bearing mounting bracket before installing shims. One 0.12 in (3 mm) thick shim will add about 0.50 in (13 mm) width to the polish mark.

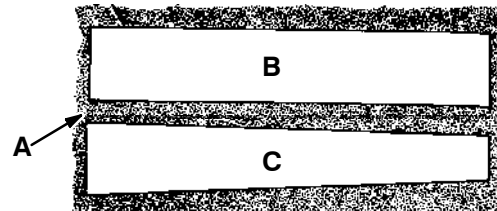

00082

TAPERED BRUSH PATTERN

**A. Operator Side
B. Rear Brush Marks
C. Front Brush Marks**

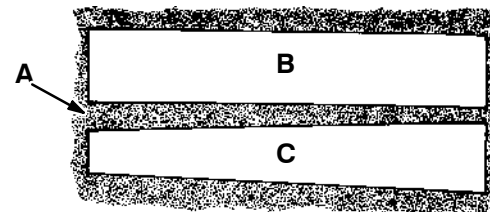

00082

TAPERED BRUSH PATTERN

**A. Operator Side
B. Rear Brush Marks
C. Front Brush Marks**

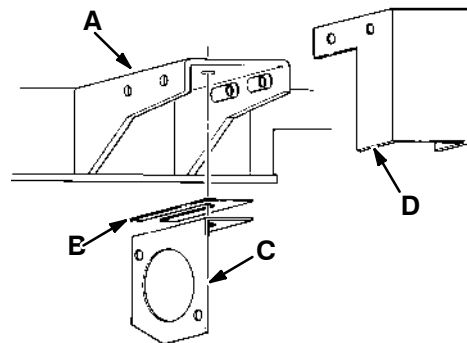

00284

BRUSH SHAFT MOUNTING

**A. Scrub Head
B. Shim
C. Bearing Mounting Bracket
D. Bearing Protector**

7. Recheck the brush polish marks to see if the front and rear match, and are even across the full length of the brush.
8. The width of the rear brush polish mark can vary more than the desired 2 to 3 in (50 to 75 mm). There are adjusting knobs located on the drive side of the scrub head. Turn the knob clockwise to decrease the width of the polish mark and counterclockwise to increase the width of the polish mark. The polish mark should not exceed 3 in (75 mm). Use the locking strips to keep the adjusting knobs in place.

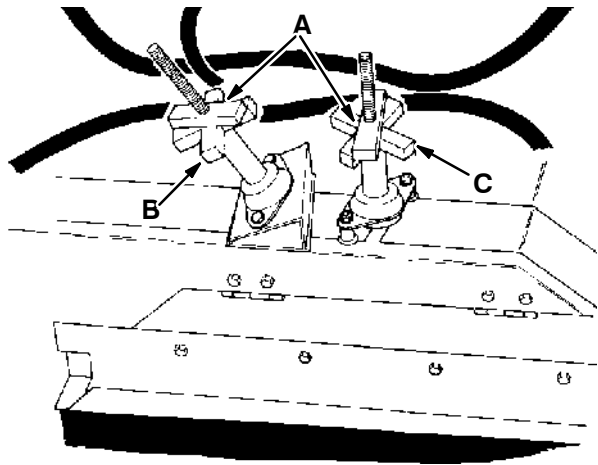

BRUSH ADJUSTMENT KNOBS

- A. Locking Strips**
- B. Front Brush Adjusting Knob**
- C. Rear Brush Adjusting Knob**

9. For maximum brush life, rotate the brushes from front-to-rear after every 50 hours of operation.

SCRUB BRUSHES

The scrub brushes are tubular and run the width of the scrub head sweeping debris into the debris trough while they scrub the floor. The brushes should be inspected daily for damage or wear. Remove any string or wire found tangled on the scrub brushes, drive or idler hubs.

Rotate the scrub brushes from front-to-rear after every 50 hours of operation for maximum brush life and best scrubbing performance.

The scrub brush patterns should be checked daily. The width of the patterns should be 2 to 3 in (50 to 75 mm). The scrub brush pattern is adjusted by turning the adjustment knobs on top of the scrub head. See *TO ADJUST SCRUB BRUSH PATTERN*.

TO REPLACE SCRUB BRUSHES

1. Raise scrub head and set scrub head lock.

! WARNING: Raised Scrub Head May Fall. Block Scrub Head Up.

2. Stop engine and set parking brake.

FOR SAFETY: Before Leaving Or Servicing Machine; Stop On Level Surface, Set Parking Brake, And Turn Off Machine.

3. Open right side door on scrub head and use the chain to hold the door in the raised position.
4. Use wrench to remove hex head bolt attaching the brush arm.

NOTE: If arm does not come off easily, insert bolt in the adjacent threaded hole and screw in until arm comes off.

5. The brush arm and brush can then be pulled out.

6. Repeat steps 4 and 5 to remove other brush.
7. Insert one end of brush through access door and push the brush in until it touches the drive plug.

It is helpful to have a second person guide the other brush end onto the drive plug while you are pushing and turning the brush until it engages the drive keyway on the plug.

8. Install the brush arm with the hex head bolt.

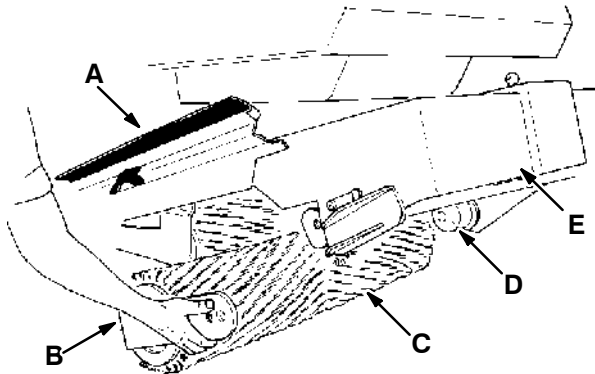

REPLACING BRUSH

00287

- A. Door**
- B. Brush Arm**
- C. Brush**
- D. Brush Drive Plug**
- E. Raised Scrubber Head**

9. Repeat the steps 7 and 8 for the other brush.
10. Unhook the chain and lower the access door.
11. Release the scrub head lock before lowering the scrub head.

SOLUTION SYSTEM

RECOVERY TANK

The recovery tank has a capacity of 120 gal (455 L). When the tank is full, a ball float will rise and shut off the vacuum to the tank. A 48 in (220 mm) long drain hose for the recovery tank is located on the front of the tank.

You can determine the water level in the recovery tank by lowering the hose end until water appears - this will then be the water level in the tank, (engine must be off; this stops vacuum).

To drain the tank, lower the hose and place it near a suitable floor drain.

NOTE: The hose will not drain until the engine is off, stopping vacuum.

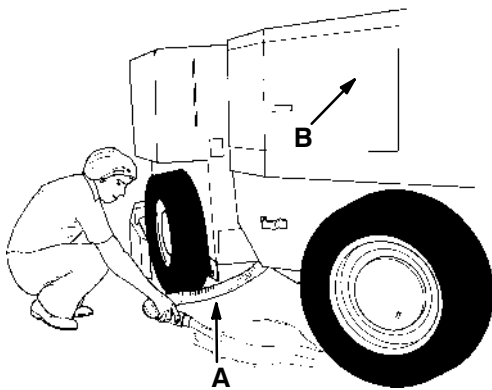

00288

DRAINING RECOVERY TANK

- A. Drain hose**
- B. Operator Side of Machine**

Three clean-out doors are provided for the recovery tank; two at the front and one at the rear of the tank.

Flush all sand, sludge, debris, etc., out of the tank. Also, check the return hoses and connections for clogging or damage.

NOTE: The clean-out door seal will leak if small particles of debris are caught between the door edge and rubber seal.

NOTE: When replacing the clean-out doors, the thumbscrews should be tightened to 20 - 50 in lb (2.26 - 5.65 Nm). Do not over-tighten. Too much torque on the thumbscrews will cause the clean-out doors to bow and cut the door seals.

Empty and clean the recovery tank after every shift. The ball float screen retainer at the top of the tank should also be cleaned when draining the tank.

NOTE: The water must not be hotter than 130° F (54° C) or tank damage may occur.

WATER SPRAY DEFLECTOR

The water spray deflector is located on the rear squeegee discharge tube inside of the recovery tank. The spray deflector deflects the spray of water and small debris picked up by the rear squeegee away from the walls of the recovery tank. The deflector should be checked for wear after every 200 hours of operation.

To check the water spray deflector for wear, the rear squeegee discharge tube must be removed. Be sure to save and reuse the rubber-backed washers which are located on the inside of the recovery tank. Inspect or replace the spray deflector. Reinstall discharge tube, using a new gasket if the existing one was damaged.

SRS WATER SPRAY DEFLECTOR

The SRS solution tank has two spray deflectors; a lower spray deflector located on the rear squeegee discharge tube inside the tank, and a top spray deflector located in the top rear of the tank. The spray deflectors deflect the spray of water and small debris away from the walls of the solution tank. The deflectors should be checked for wear after every 200 hours of operations.

To check the lower spray deflector for wear, the rear squeegee discharge tube must be removed from the rear of the tank. Be sure to save the rubber seal washers which are located on the inside of the tank. Inspect the spray deflector for wear. If replacement is necessary, install a new deflector into the spray deflector frames, and mount the deflector to the rear squeegee discharge tube. Reinstall the discharge tube into the rear of the tank. Use a new discharge tube gasket if the existing one is damaged.

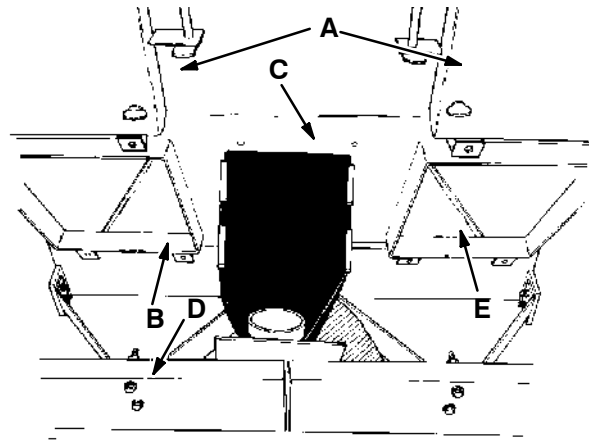

INSTALLING LOWER SPRAY DEFLECTOR

- A. Top Rear Clean-Out Doors**
- B. Bottom Clean-Out Door**
- C. Spray Deflector**
- D. Rear Bumper**
- E. Bottom Clean-Out Door**

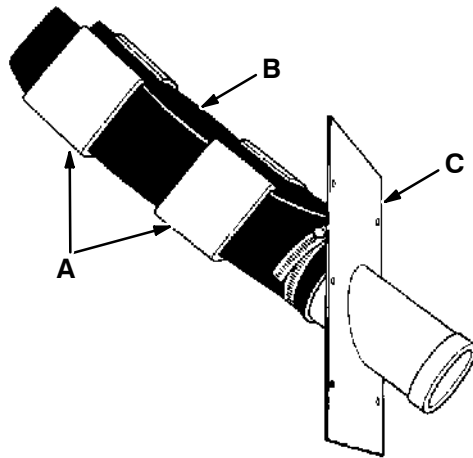

CORRECT POSITIONING OF LOWER SPRAY DEFLECTOR

- A. Spray Deflector Frames**
- B. Spray Deflector**
- C. Rear Squeegee Discharge Tube**

To check the top spray deflector for wear, remove the top access cover at the top rear of the solution tank. Inspect the deflector for wear. Remove the deflector if replacement is necessary. Replace the top access cover gasket if the gasket is damaged. To install the spray deflector back into the tank, slide the bottom of the deflector down the back of the tank. Then, with the top cover gasket in place on the solution tank, position the deflector to follow the curvature of the bottom of the access cover. Clamp the top access cover in place.

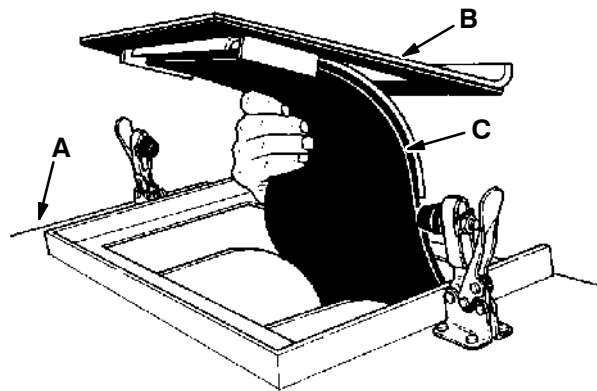

INSTALLING TOP SPRAY DEFLECTOR

- A. Solution Tank**
- B. Top Access Cover**
- C. Spray Deflector**

MAINTENANCE

SRS SOLUTION TANK

The tank has a capacity of 265 gal (1000 L). When the tank is full, a ball float will rise and shut off the vacuum to the tank. A 72 in (1830 mm) long drain hose for the recovery tank is located on the front of the tank. You can determine the water level in the tank by lowering the hose end until water appears—this will then be the water level in the tank, (engine must be off; this stops vacuum). To drain the tank, lower the hose and place in suitable floor drain.

Empty and clean the solution tank and flush the laminar tubes after every shift.

Partially fill the solution tank with clean water. Run the SRS pump for a few minutes to flush the solution hoses.

NOTE: The water must not be hotter than 130°F (54°C) or tank damage may occur.

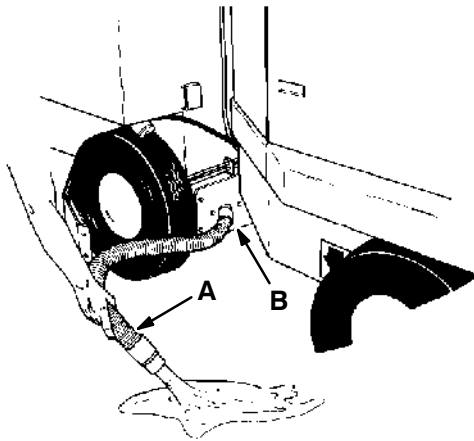

DRAINING SOLUTION TANK

00343

- A. Drain Hose**
- B. Clean-out Door**

Six clean-out doors are provided on the tank: two at the front, two at the upper rear, and two at the lower rear of the tank. Using the sludge removal tool, remove all sand, sludge, debris, etc., from the tank. Remove the two large plugs above the tank tires near the upper front of the tank. Flush the sediment from all compartments of the tank and the wire mesh filters. Check for dirt buildup in the laminar flow tubes. To clean tubes, remove and flush. Also, check the return hoses and connections for clogging or damage.

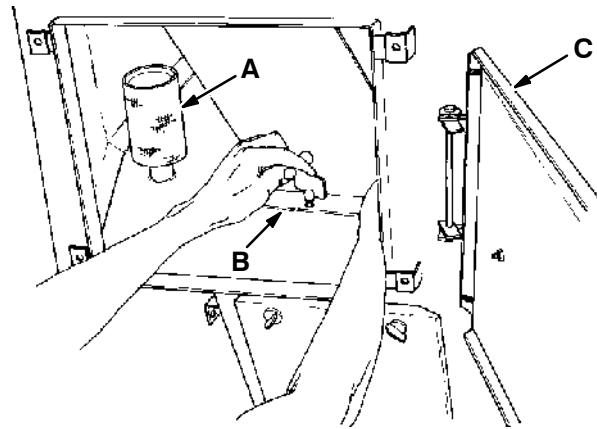

REMOVING LAMINAR TUBES

00345

- A. Solution Outlet Filter**
- B. Laminar Tube Set Fastener**
- C. Upper Rear Clean-Out Door**

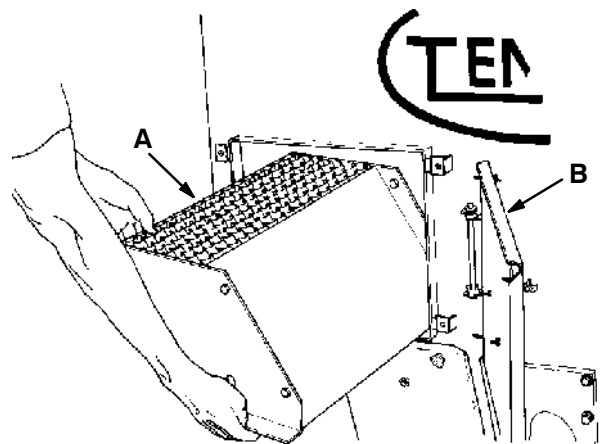

REMOVING LAMINAR TUBES

00342

- A. Laminar Tube Set**
- B. Upper Rear Clean-Out Door**

NOTE: Keep laminar tube sections facing the outside of the machine.

SOLUTION DISPENSING TUBE

The solution dispensing tube has a flushing connection built in. The flushing connection is the tee fitting next to the solution control valve. This allows a garden hose to be threaded into the dispensing system to flush the system. Flush the system after every 50 hours of operation.

SRS METERING SOLUTION PUMP

A bellows pump meters cleaning solution into the recycling solution at rates of one-quarter, one-half and one percent. The cleaning solution is introduced to the recycling solution at a point just before the spray nozzle. Clean the metering pump daily when cleaning the solution tank.

TROUBLESHOOTING**Low Flow**

1. Poppet valves dirty, dried cleaning solution residue on valves.
2. Restriction in cleaning solution lines.
3. Air leak at pump intake.
4. Defective wiring or motor.

Motor Fails to Turn On

1. Loose wiring connection.
2. Defective motor.

Motor Operates, But No Pump Discharge

1. Damaged bellows.
2. Restriction in cleaning solution lines.
3. Air leak in intake line.
4. Unprimed pump.
 - a. Remove pump inlet hose.
 - b. Fill pump chamber with approximately one ounce SRS solution.
 - c. Reinstall pump inlet hose.
 - d. Pump should start metering tank solution after 3 to 4 minutes run time.

SQUEEGEES

SIDE SQUEEGEES

The side squeegees control scrub brush water spray. They consist of a squeegee blade, backup strip, band, and clamp. Check the side squeegee blades for damage or wear daily. Replace squeegee blade by opening the quick-release latch and removing the band. Remove the bracket, old blade, and backup strip. Replace the squeegee blade and backup strip if the blade is worn.

Adjust the squeegee clamp so that there is adequate pressure to hold the squeegee blade in place. The squeegee blade should be held so that it cannot be pulled from between the locating pins.

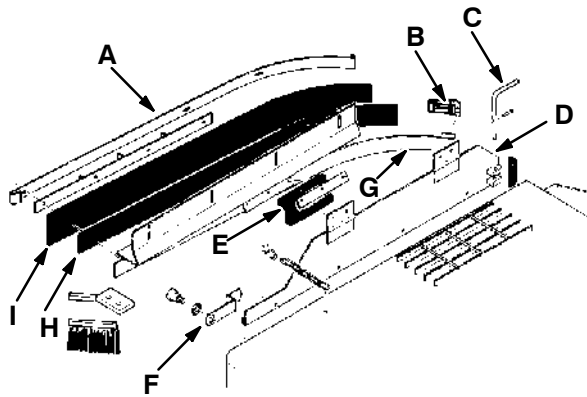

SIDE SQUEEGEE ASSEMBLY

- A. Retaining Band
- B. Latch
- C. Door Locking Pin
- D. Door
- E. Flap
- F. Door Latch
- G. Squeegee Frame
- H. Backup Strip
- I. Squeegee Blade

The side squeegee frame is attached to the squeegee door with four screws. The screw mounting holes are slotted, allowing vertical adjustment of the squeegee blade by simply loosening the screws and moving the squeegee up or down. Check the side squeegee blades adjustment daily.

Lower the head and adjust the squeegee so that the blade deflects 0.50 in (13 mm). The squeegee should deflect evenly across its entire length.

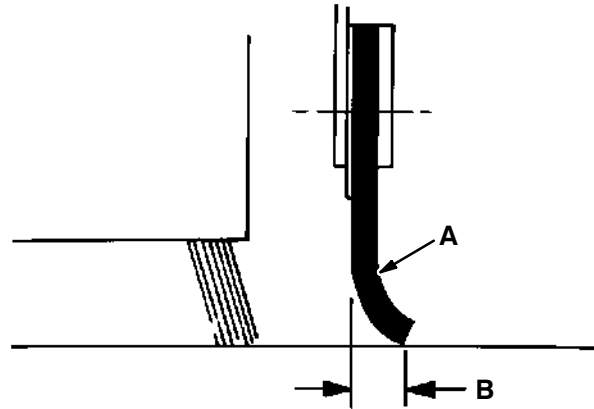

SIDE SQUEEGEE BLADE DEFLECTION

- A. Side Squeegee Blade
- B. 0.50 in (13 mm) Deflection

REAR SQUEEGEE

The rear squeegee assembly channels water into the vacuum fan suction. When properly maintained, the squeegee should leave floors nearly dry. The assembly consists of a front and rear blade held in place by bands and clamps. Two back-up strips are used with the rear blade. Check the rear squeegee for damage or wear and adjustment daily.

The rear squeegee has been factory adjusted. The factory adjustments need to be done only after replacing a major component of the rear squeegee assembly. Regular squeegee adjustments are covered in *TO ADJUST REAR SQUEEGEE*.

TO REPLACE REAR SQUEEGEE BLADES

1. Stop the engine and set the parking brake.

FOR SAFETY: Before Leaving Or Servicing Machine; Stop On Level Surface, Set Parking Brake, And Turn Off Machine.

2. Open the band clamp and remove all parts.
3. Place the new squeegee blade over the pins on the frame.
4. Next, fit the two back-up strips on the pins. Inner strip down, outer strip up.
5. Position the retaining band in place and engage the clamp.
6. The front blade is replaced in the same manner, except that backup strips are not used.
7. Adjust the squeegee clamp so that there is adequate pressure to hold the squeegees in place. The squeegee blades should be held so they cannot be pulled from between the locating pins. After proper adjustment is made, lock each adjusting screw with a jam nut.

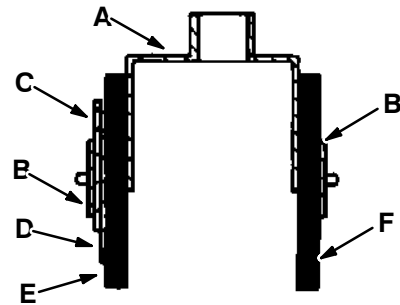

REAR SQUEEGEE CROSS-SECTION

00151

- A. Squeegee Frame**
- B. Band**
- C. Outer Back-Up Strip**
- D. Inner Back-Up Strip**
- E. Rear Blade**
- F. Front Blade**

NOTE: Install back-up strips with outer strip up, inner strip down.

TO FACTORY ADJUST REAR SQUEEGEE

NOTE: The solution tank must be full, and the tires must be correctly inflated to properly adjust the rear squeegee.

1. LINKAGE PIVOTS

Check the squeegee linkage pivot points and, if necessary, tighten the locknuts on each bearing joint in the linkage. Tighten each locknut until the joint is just short of locking up. The linkage must be snug, but still free enough to rotate the linkage by hand.

2. SQUEEGEE LIFT CYLINDER

The squeegee lift cylinder rod end should be adjusted so there is 5.50 ± 0.12 in (140 ± 3 mm) between the cylinder rod hole and the rod end hole should be 6.00 ± 0.12 in (150 ± 3 mm).

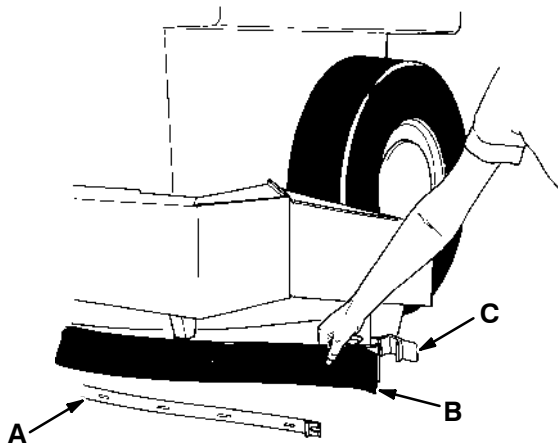

REAR SQUEEGEE

00290

- A. Band**
- B. Blade and Back-Up Strips on Pins**
- C. Clamp**

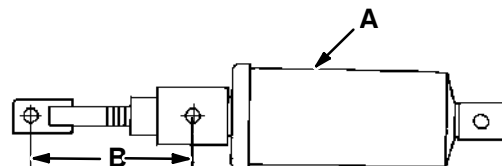

SQUEEGEE LIFT CYLINDER

01725

- A. Cylinder**
- B. Adjustment Length**

3. EYEBOLTS

The eyebolts should be adjusted so there is 1.38 ± 0.12 in (35 ± 3 mm) between the end of the eyebolt and the top of the arm on each side of the squeegee.

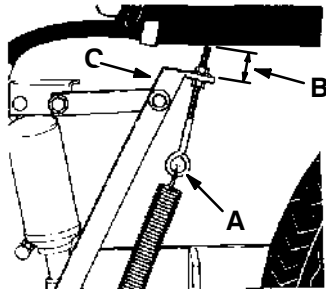

EYEBOLT

01726

- A. Eyebolt
- B. 1.38 ± 0.12 in (35 ± 3 mm)
- C. Arm

4. CASTERS

The caster should be in good condition and be free to spin. The center caster should be 0.25 ± 0.06 in (6 ± 2 mm) off the floor with the squeegee blade perpendicular to the floor. The tip casters should touch the floor with the squeegee blade perpendicular to the floor.

5. ARM CLEARANCE

The distance between the arm assembly and the squeegee lift shaft arm should be 1 to 1.25 in (25 to 30 mm) with the squeegee blade down and perpendicular to the floor.

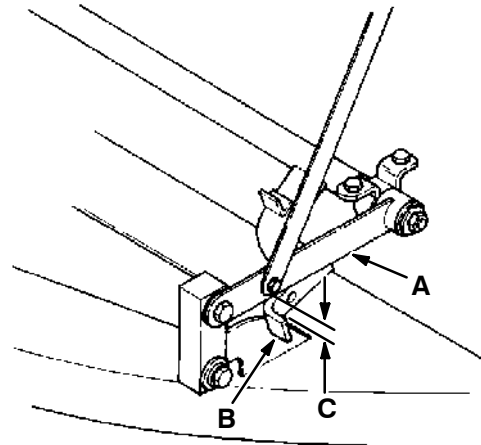

ARM CLEARANCE

01728

- A. Arm Assembly
- B. Squeegee Lift Shaft Arm
- C. 1 to 1.25 in (25 to 30 mm)

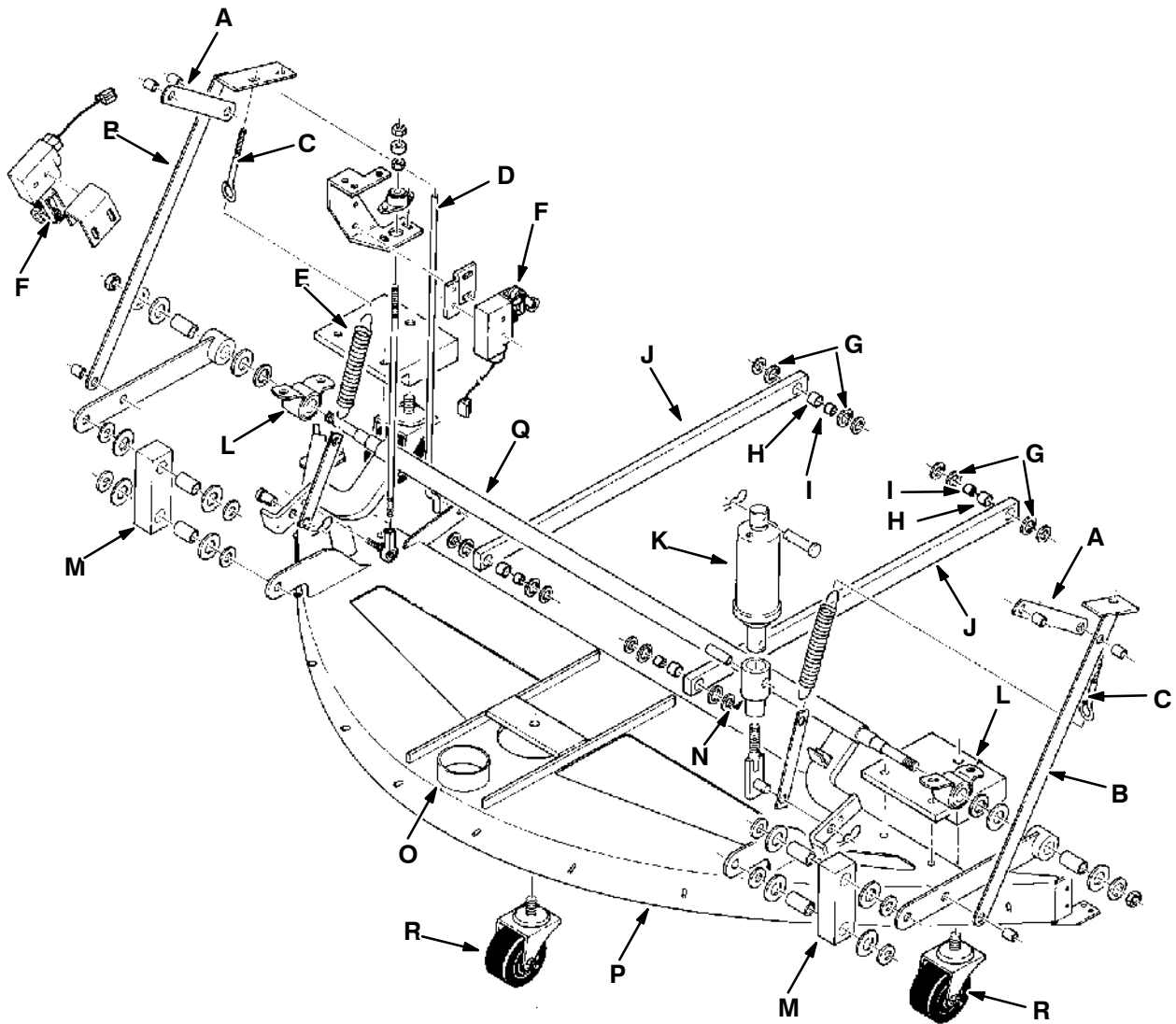

REAR SQUEEGEE LINKAGE

00191

- | | |
|---------------------------------|----------------------------------|
| A. Link | J. Front Drag Link |
| B. Arm | K. Squeegee Lift Cylinder |
| C. Eyebolt | L. Bearing |
| D. Squeegee Tip Lift Rod | M. Block Link |
| E. Down Pressure Spring | N. Cylinder Rod End |
| F. Roller Switch | O. Vacuum Hose Connection |
| G. Fiberglass Washer | P. Squeegee Frame |
| H. Bearing | Q. Lift Shaft |
| I. Sleeve | R. Caster |

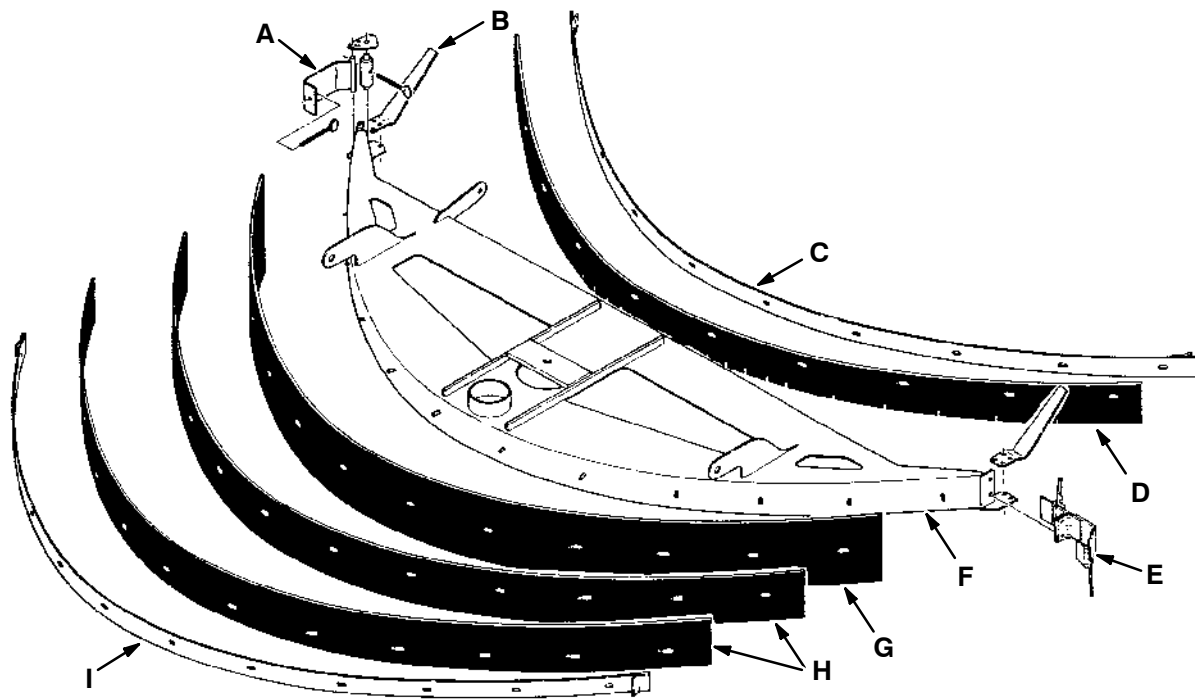

REAR SQUEEGEE

00196

- | | |
|------------------------|-------------------------|
| A. Adjuster | F. Frame |
| B. Spring Guide | G. Rear Blade |
| C. Front Band | H. Back-Up Strip |
| D. Front Blade | I. Band |
| E. Band Clamp | |

TO ADJUST REAR SQUEEGEE

1. Lower the rear squeegee and drive the machine slowly forward to observe the squeegee roll-out. Adjust the squeegee roller height adjustment stud or add or remove washers from the caster to get an even roll-out. The top nut acts as a locknut. The nut just under the squeegee frame is the adjusting nut. Loosen the locking nut and turn the adjusting nut clockwise to increase down pressure, or counterclockwise to decrease pressure. Tighten the locknut after adjusting the adjusting nut.

2. Lower the rear squeegee and drive the machine slowly forward to observe the tips of the squeegee.

- a. If both tips are too low, tighten both eyebolts which increases the down pressure on the back side of the squeegee frame to lift both tips.

- b. If both tips are too high, loosen both eyebolts which decreases the down pressure on the back side of the squeegee frame to lower both tips.
- c. If just one tip is too low, loosen the eyebolt on the side that is too low. If the tip is still too low, tighten the eyebolt on the opposite side.
- d. If just one tip is too high, tighten the eyebolt on the side that is too high. If the tip is still too high, loosen the eyebolt on the opposite side.

NOTE: The number of washers on the squeegee tip casters may need to be changed to properly adjust the squeegee tips.

3. After the tips are adjusted, make sure the eyebolt adjustments are locked in place. The center of the squeegee may have to be readjusted to get an even roll-out across the squeegee. If the squeegee roll-out is set too small, the squeegee will skip when traveling on a uneven floor.
4. Lower the rear squeegee. The lower squeegee switch roller should be in line and tripped by the top of the trip barrel. Adjust the trip barrel position on the threaded rod to adjust.

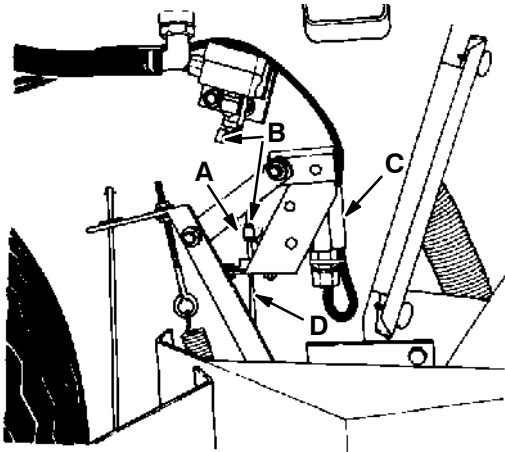

LOWERED SQUEEGEE

02357

- A. Trip Barrel**
- B. Switch Roller**
- C. Lower Switch**
- D. Threaded Rod**

Raise the rear squeegee. The upper squeegee switch roller should be tripped by the squeegee link. The lower squeegee switch roller should be free standing.

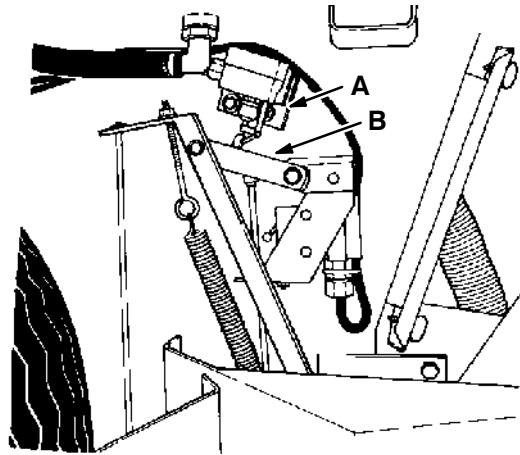

RAISED SQUEEGEE

02358

- A. Upper Switch**
- B. Link**

After both switches are properly adjusted with the engine operating, put the instrument panel squeegee switch in the "Down" position. The squeegee should lower. Press the directional pedal into the "reverse" direction. The squeegee should rise as soon as the machine moves backward. Press the directional pedal into the "forward" direction. The squeegee should lower.

BRAKES AND TIRES

SERVICE BRAKES

The service brakes are hydraulically activated by a master brake cylinder.

Check the master brake cylinder fluid level after every 400 hours of operation and add brake fluid as needed. The master brake cylinder is located at the front of the machine. Open the front compartment door for access to the master cylinder.

If necessary, adjust brake linkage as follows: adjust clevis on master cylinder push rod so that brake pedal is in a horizontal position when the cylinder push rod starts to engage the cylinder piston.

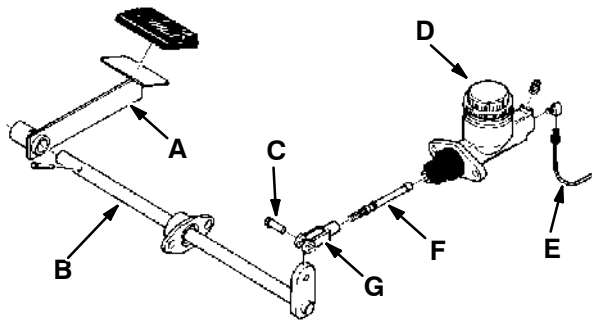

00105

BRAKE SYSTEM COMPONENTS

- A. Brake Pedal
- B. Shaft
- C. Pin
- D. Master Brake Cylinder
- E. Brake Line
- F. Push Rod
- G. Clevis

Brakes require bleeding whenever air enters the system, lowering the effective braking pressure. Air can enter when the master cylinder or wheel cylinders are serviced or if the fluid in the reservoir runs dry. Air can also enter through a leaky brake line or hose. Find the leaking line and replace it before bleeding.

Whenever handling brake fluid, do not get any on the brake pads, brake discs, calipers, or body paint. Brake pads will be permanently damaged, requiring replacement. Body paint can be damaged also unless you wipe the area with a clean cloth and wash it with a soapy solution immediately.

1. Make sure that the brake fluid reservoir is full and that the vent in the cap is open.

2. Connect a plastic or rubber tube to the bleeder valve on the left front wheel. Suspend the other end of the tube in a jar or bottle filled with a few inches of brake fluid. During the remaining steps, keep this end submerged at all times and never let the level in the brake fluid reservoir drop below one half full.
3. Open the bleeder valve and plug on the left front wheel about one turn. Have an assistant press the brake pedal slowly to the floor. As soon as the pedal is all the way down, close the bleeder valve and let the pedal up. Repeat this step as many times as necessary, until fluid with no air bubbles exits from the tube.
4. Bleed the right front wheel in the same manner as described in the steps above. Keep checking the brake fluid reservoir to be sure it doesn't run out of fluid.
5. When all wheels are bled, discard the brake fluid in the jar or bottle; never reuse such fluid.
6. Top up the brake fluid reservoir with clean fluid.

PARKING BRAKES

The parking brakes are mechanically activated by the parking brake lever and two cables.

The parking brake cables should be adjusted after every 200 hours of operation or whenever the machine rolls after setting the parking brake or when it becomes very easy to set the parking brake. To adjust the brake cables, turn the knurled knob on the end of the parking brake clockwise. Tighten the brake cable enough to make the parking brake slightly resist being set.

TIRES

The machine is equipped with four pneumatic tires. The air pressure in these tires is critical to machine performance. Check the tire pressure daily. The correct tire pressures are: 55 psi (380 kPa) front, 35 psi (240 kPa) rear.

Tighten the wheel lug nuts in the pattern shown, after every 200 hours of operation. Tighten lug nuts 85 to 95 ft lb (115 to 130 Nm).

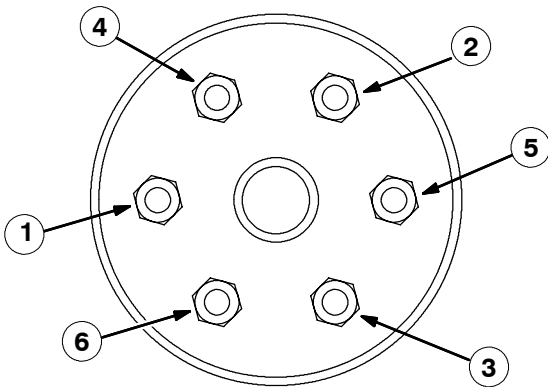

OPTIONS

HIGH PRESSURE SPRAYER

The high pressure sprayer option requires some periodic maintenance to keep it operating properly.

Fill the crankcase and oil wicks according to the following instructions. Operate and maintain the pump only as directed.

The pump must not be run dry and must be drained of water prior to exposure to freezing temperatures.

NOTE: Do not pump acids, abrasive, or flammable fluids with this unit.

Crankcase - Fill crankcase to the dot on the oil gauge window with 1.25 pt (0.6 L) of genuine Cat Pump Crankcase Oil.

Change the oil after a 50 hour run-in period. Then change the oil every three months or at 500 hour intervals when using genuine Cat Pump Crankcase Oil. If other approved oil is used, change oil every month or at 200 hour intervals.

Piston Rod Wicks - Prior to initial operation, saturate the piston rod wicks and fill the reservoir (approximately 60 drops of oil - two pumps of a push-type oil can in each of the three lubricator housing holes). Add 30 drops of oil to each hole every week or 100 hours of operation.

Filter - The in-line solution filter must be cleaned or replaced after the 50 hour run-in period and every three months or 500 hours of service.

MACHINE SPECIFICATIONS

POWER TYPE

CONTINENTAL ENGINES - (For machines below serial number 006409)

Engine manufacturer/model - Continental TMD27
 Engine type - piston
 Ignition - diesel
 Cycle - 4
 Aspiration - natural
 Cylinders - 4
 Bore - 3.58 in (90 mm)
 Stroke - 4.06 in (105 mm)
 Displacement - 164 cu in (2.7 L)
 Net power - 55 hp (40 kw) @ 2400 rpm governed 66 hp (50 kw) @ 3000 rpm maximum
 Fuels - #1 or #2 diesel fuel
 Cooling system - water
 Electrical system - 12 V nominal, 42 A alternator

PERKINS ENGINES - (For machines serial number 006409-007002)

Engine manufacturer/model - Perkins 704-30 Series
 Engine type - piston
 Ignition - solid state distributor
 Cycle - 4
 Aspiration - natural
 Cylinders - 4
 Bore - 3.80 in (97.00 mm)
 Stroke - 3.90 in (100.00 mm)
 Displacement - 181 cu in (3.0 L)
 Net power: - 63 hp (44.8 kw) @ 2400 rpm governed 63 hp (47 kw) @ 2400 rpm maximum
 Fuels - Diesel
 Cooling system - water/ethylene glycol antifreeze
 Electrical system - 12 V nominal, 50 A alternator (std), 100 A alternator (HD)

CAT ENGINES - (For machines serial number 007003 and above)

Engine manufacturer/model - CAT 3044C
 Engine manufacturer/model - CAT C3.4
 Engine type - piston
 Ignition - solid state distributor
 Cycle - 4
 Aspiration - natural
 Cylinders - 4
 Bore - 3.70 in (94.00 mm)
 Stroke - 4.70 in (120.00 mm)
 Displacement - 201 cu in (3.33 L)
 Net power: - 62 hp (46.2 kw) @ 2400 rpm governed 63 hp (47 kw) @ 2600 rpm maximum
 Fuels - Diesel
 Cooling system - water/ethylene glycol antifreeze
 Electrical system - 12 V nominal, 75 A alternator (std), 100 A alternator (HD)

POWER TRAIN

Propelling - hydraulic drive motors (2)
 Scrub brush - hydraulic drive motors (2)
 Vacuum fan - belt driven

STEERING

Type - articulated frame
 Power source - double action hydraulic cylinder
 Emergency steering - manual

SPECIFICATIONS

HYDRAULIC SYSTEM

Function - operates propelling, steering, scrub brush drive, scrub head lift, rear squeegee lift.

Control valve, scrub brush drive, scrub head lift - open center, single spool.

Control valve, squeegee position - two position, electrical solenoid actuated.

Propelling pump - variable displacement piston type, 20.9 gpm (80 L/min) @ 2400 rpm

Propelling pump - variable displacement piston type, 22.7 gpm (86 L/min) @ 2200 rpm

Propelling system rated pressure - 4500 psi (31,030 kPa)

Scrub brush drive pump - vane type, 17.2 gpm (65 L/min) @ 2400 rpm

Scrub brush drive system rated pressure - 2500 psi (17,240 kPa)

Accessories pump - vane type, 6.2 gpm (25 L/min) @ 2400 rpm

Accessories pump - gear type,
front section: 15.8 gpm (60 L/min) @ 2400 rpm
rear section: 4 gpm (15 L/min) @ 2400 rpm

Accessories system rated pressure - 2000 psi (13,790 kPa)

Propelling motor (2) internal gear type, 17 cu in (275 cc) per revolution, 1750 psi (12,065 kPa) maximum rated pressure

Scrub brush drive motor (2) - internal gear type, 9.9 cu in (160 cc) per revolution, 1200 psi (8275 kPa) maximum rated pressure

Scrub head lift cylinder - single action type, 2 in (50 mm) bore x 4 in (100 mm) stroke, 1 in (25 mm) diameter rod, 1500 psi (10,345 kPa) maximum rated pressure

Rear squeegee lift cylinder - double action type, 2 in (50 mm) bore x 4 in (100 mm) stroke, 1 in (25 mm) diameter rod, 1500 psi (10,345 kPa) maximum rated pressure.

Steering cylinder - double action type, 2 in (50 mm) bore x 11 in (280 mm) stroke, 1 in (25 mm) diameter rod, 2000 psi (13,790 kPa) maximum rated pressure

BRAKING SYSTEM

Service brakes - hydraulic caliper disc brakes (2), (one per front wheel) foot brake master cylinder actuated.

Parking brakes - mechanical caliper disc brakes (2), (one per front wheel), cable actuated.

SUSPENSION SYSTEM

Front - two 8.00 x 16.5 6-ply rating tubeless tires
Rear - two 8.00 x 16.5 6-ply rating tubeless tires

SYSTEM FLUID CAPACITIES

Engine cooling system, radiator - 6.4 qt (6 L)
Engine cooling system, total system - 13.4 qt (13 L)

Fuel tank - 15.3 gal (60 L)

CONTINENTAL ENGINES - (For machines below serial number 006409)
Engine lubricating oil - 7 qt (6.5 L)

PERKINS ENGINES - (For machines serial number 006409-007002)
Engine lubricating oil - 11 qt (10.4 L)

CAT ENGINES - (For machines serial number 007003 and above)
Engine lubricating oil - 10.6 qt (10.0 L)

Hydraulic system, reservoir - 11.5 gal (45 L)
Hydraulic system, total system - 13.8 gal (52 L)

Standard solution tank - 140 gal (530 L)

Standard recovery tank - 120 gal (455 L)

SRS solution tank - 265 gal (1000 L)

SRS cleaning solution tank - 10 gal (37 L)

**GENERAL MACHINE
DIMENSIONS/CAPACITIES**

Length - 156 in (3960 mm)

Width - 61 in (1550 mm)

Height - 61 in (1550 mm)

Height with overhead guard - 84 in
(2130 mm)

Track, front - 46.7 in (1185 mm)

Track, rear - 45.3 in (1150 mm)

Wheel base - 58.75 in (1490 mm)

Scrub brush (2), path width - 50 in (1270 mm)

Scrub brush (2), diameter - 11 in (280 mm)

Rear squeegee path width - 56.5 in (1435 mm)

Debris hopper capacity - 2.6 cu ft (0.073 m³)

MACHINE WEIGHTS

GVWR - 7200 lb (3265 kg)

GENERAL MACHINE PERFORMANCE

Maximum forward speed - 9 mph (14.5 km/h)

Maximum reverse speed - 5 mph (8 km/h)

Turning radius, right - 109 in (2770 mm)

Turning radius, left - 100 in (2540 mm)

Maximum rated climb and descent angle - 10°

Maximum rated climb and ascent angle when
tanks are full - 8°

SPECIFICATIONS

MACHINE DIMENSIONS

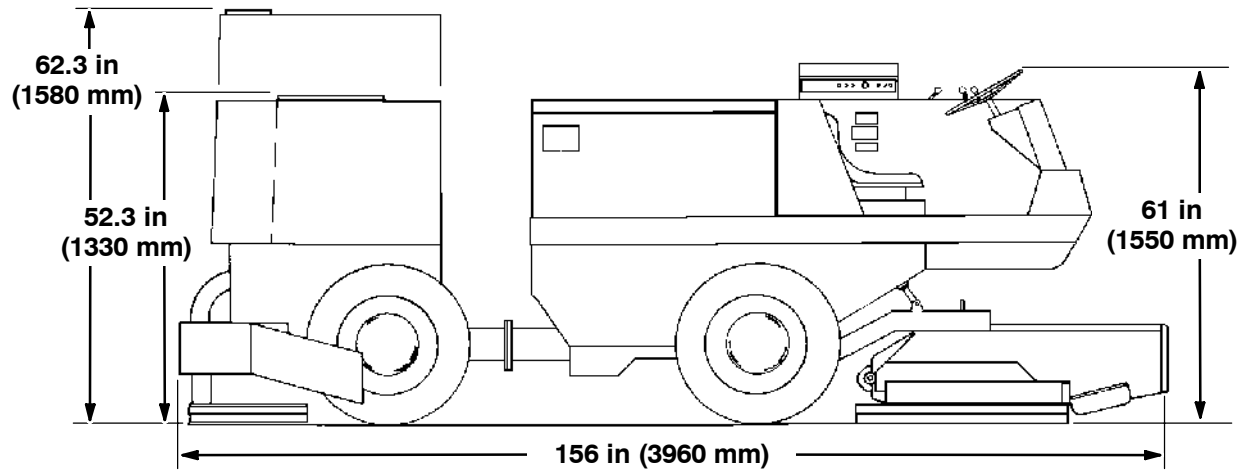

SIDE VIEW

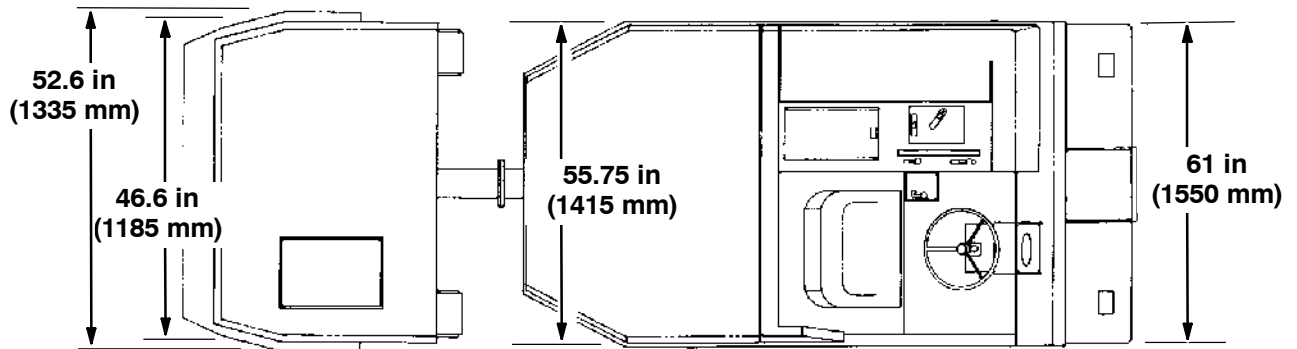

TOP VIEW

00362

A

Adjusting rear squeegee blade deflection, 60
 Adjusting side squeegee blade deflection, 56
 Air filter, 37
 Air filter service indicator, 37
 Air filter system, heavy duty SE filter, 39
 Air intake system, 37
 Aisle turn, 67
 Alternator and radiator fan belt, To adjust
 alternator and radiator fan belt, 47
 Ammeter, 13

B

Battery, 46
 Ammeter, 13
 charging system light, 13
 Belts, 47
 Alternator and radiator fan belt, 47
 Vacuum fan drive belt, 47
 To adjust vacuum fan drive belt, 47
 Brake pedal, 12
 Brakes, 62
 Machine specifications, 66
 Parking, Adjustment, 63
 Service, 62
 Brushes
 Scrub brush lever, 15
 Scrub head position lever, 16
 Bypass valve, 23

C

Capacities, 67
 Chains, 47
 Circuit breakers, 15
 Control panel
 Ammeter, 13
 charging system light, 13
 Circuit breakers, 15
 Diesel pre-heat lamp, 14
 Engine coolant temperature, 15
 Engine hour meter, 14
 Engine oil pressure, 15
 engine oil pressure light, 15
 Fuel level gauge, 14
 Fuses, 14
 Hazard light switch, 14
 Operating lights switch, 14
 Panel lamp, 14
 Rotating light switch, 14

Scrub brush lever, 15
 Scrub head position lever, 16
 Solution lever, 16
 Squeegee position lamp, 13
 Squeegee switch, 15
 SRS cleaning solution flow knob, 16
 SRS liquid low level lamps, 16
 Tank drain lamp, 13
 Throttle lever, 16
 Throttle switch, 16
 Controls, 10, 11
 Ammeter, 13
 Brake pedal, 12
 Circuit breakers, 15
 Diesel pre-heat lamp, 14
 Directional pedal, 12
 Engine coolant temperature gauge, 15
 Engine hour meter, 14
 Engine oil pressure gauge, 15
 Fuel level gauge, 14
 Fuses, 14
 Hazard light switch, 14
 Ignition switch, 13
 Operating lights switch, 14
 Operation, 9–22
 Parking brake lever, 13
 Rotating light switch, 14
 Scrub brush lever, 15
 Scrub brush pressure lamp, 13
 Scrub head lock lever, 12
 Scrub head position lever, 16
 Solution lever, 16
 Squeegee position lamp, 13
 Squeegee switch, 15
 SRS cleaning solution flow knob, 16
 SRS liquid low level lamps, 16
 Steering wheel, 14
 Tank drain lamp, 13
 Throttle lever, 16
 Throttle switch, 16
 Cylinder head, 44
 Cylinder head bolt tightening – Continental
 engines, 44
 Cylinder head bolt tightening – Perkins engines,
 44

D

Debris hopper, Empty and clean, 20
Diesel pre-heat lamp, 14
Dimensions, 67
Directional pedal, 12
Double scrubbing, 20

E

Electrical
 Battery, 46
 Circuit breakers, 15
 Fuses, 14
 Ignition switch, 13
Electrical system, 46
Engine, 36–38
 Air filter, 37
 Air filter service indicator, 37
 Air intake system, 37
 Alternator and radiator fan belt, 47
 Cooling system, 36
 Cylinder head, 44
 Cylinder head bolt tightening - Continental engines, 44
 Cylinder head bolt tightening - Perkins engines, 44
 Engine coolant temperature, Light, 15
 Fuel filters, 40
 In-line fuel filter - Perkins engines, 42
 To replace fuel filter - Continental engines, 40
 To replace fuel filter - Perkins engines, 41
 Fuel water trap, 40
 To clean water trap, 40
 Fuel injection pump, 42
 Fuel injectors, 42
 Fuel system, 40
 Lubrication, 30, 36
 Machine specifications, 65
 Oil pressure, Light, 15
 oil pressure light, 15
 Priming the fuel system - Continental engines, 43
 Priming the fuel system - Perkins engines, 43
 Throttle lever, Light, 16
 Throttle switch, Light, 16
 To replace air filter element, 38, 39
 Water separator/fuel filter, Water separator/fuel filter - Cat engines, 41
Engine coolant temperature gauge, 15
Engine hour meter, 14
Engine oil pressure gauge, 15

F

Fluid capacities, Machine specifications, 66
Fuel filters, 40
Fuel injection pump, 42
Fuel injectors, 42
Fuel level gauge, 14
Fuel system, 40
Fuel water trap, 40
Fuses, 14

G

Gauge, Fuel level, 14
Gauges
 Ammeter, 13
 Engine coolant temperature, 15
 Engine oil pressure, 15

H

Hazard light switch, 14
High pressure sprayer, 22, 64
Hydraulic components troubleshooting, 35
Hydraulic fluid, 32
Hydraulic fluid filter, 34
Hydraulic fluid reservoir, 32
Hydraulic fluid reservoir breather, 34
Hydraulic hoses, 34
Hydraulics, 32–34
 Components troubleshooting, 35
 Fluid, 32–34
 Fluid level, 33
 Hoses, 34
 Hydraulic fluid filter, 34
 Hydraulic fluid reservoir breather, 34
 Machine specifications, 66
 Reservoir, 32

I

Ignition switch, 13
In-line fuel filter - Perkins engines, 42

J

Jack points, 25

K

Knobs, SRS cleaning solution flow knob, 16

L

Lamps

Diesel pre-heat lamp, 14
 Panel lamp, 14
 Scrub brush pressure lamp, 13
 Squeegee position lamp, 13
 SRS liquid low level lamps, 16
 Tank drain lamp, 13

Leveling the rear squeegee, 57

Levers

Parking brake, 13
 Scrub brush, 15
 Scrub head lock lever, 12
 Scrub head position, 16
 Solution lever, 16
 Throttle lever, 16

Lights

battery charging system, 13
 engine oil pressure, 15
 Hazard light switch, 14
 Operating lights switch, 14
 Rotating light switch, 14
 Squeegee position lamp, 13

Lubrication, 30

Engine, 30, 36
 Machine pivot, 30
 Rear squeegee casters, 31
 Rear wheels, 31
 Scrub brush idler plugs, 31
 Scrub head hinges, 31
 Scrub head pivot, 31
 Vacuum fan shaft, 30

M

Machine components, 9

Machine dimensions, 68

Machine jacking, 25

Machine leaks, 20

Machine operation, 17

Machine pivot, 30

Machine specifications, 65–67

Braking system, 66
 Hydraulic system, 66
 Machine capacities, 67
 Machine dimensions, 67
 Machine performance, 67
 Machine weights, 67
 Power train, 65

Power type, 65

Continental engines, 65

Perkins engines, 65

Steering, 65

Suspension system, 66

System fluid capacities, 66

Machine tie down location, 24

Machine weights, Machine specifications, 67

N

Normal scrubbing information, 17

O

Operating lights switch, 14

Operation, 8–53

Operation on grades, 20

Operator seat, 12

Options, 64

Hazard light switch, 14

High pressure sprayer, 22–24, 64

Operating lights switch, 14

Panel lamp, 14

Rotating light switch, 14

SRS cleaning solution flow knob, 16

SRS liquid low level lamps, 16

Vacuum wand, 22–24

Options operation, 22–24

P

Panel lamp, 14

Parking brake, 63

Parking brake lever, 13

Pedals

Brake, 12

Directional, 12

Pivot lock pin, 13

Post operation checklist–engine operating, 20

Post operation checklist–engine stopped, 20

Power train, Machine specifications, 65

Pre-start checklist, 17

Priming the fuel system – Continental engines, 43

Priming the fuel system – Perkins engines, 43

R

Radiator, 36
 Coolant level, 36
 Coolant type, 36
 Flushing system, 36

Rear squeegee, 56–58
 Blade deflection, 60
 Leveling, 57
 Replacing blades, 57–59

Rear squeegee casters, 31

Rear wheels, 31

Recommended first 50-hour machine inspection, 27–48

Recovery tank, 52
 Drain and clean, 20
 Tank drain lamp, 13

Replacing rear squeegee blades, 57–59

Replacing side squeegee blades, 56

Rotating light switch, 14

S

Safety
 Labels, 6
 Precautions, 5–7

Scrub brush idler plugs, Lubrication, 31

Scrub brush lever, 15

Scrub brush pressure lamp, 13

Scrub brushes, 50–53
 Check, 20
 Checking brush pattern, 20
 Lever, 15, 16
 Replacing, 50–52

Scrub head, 48–51
 To adjust scrub brush pattern, 48
 To adjust scrub head pattern, 48

Scrub head hinges, Lubrication, 31

Scrub head lock lever, 12

Scrub head pivot, 31

Scrub head position lever, 16

Scrubbing, Double, 20

Seat, 12
 Adjustment, 12

Side squeegee, Blade deflection, 56

Side squeegees, 56
 Replacing blades, 56

Solution dispensing tube, 55

Solution lever, 16

Solution system, 52
 Recovery tank, 52
 Solution dispensing tube, 55
 Solution lever, 16
 SRS cleaning solution flow knob, 16
 SRS liquid low level lamps, 16
 SRS metering solution pump, 55
 SRS solution tank, 54
 SRS water spray deflector, 53
 Troubleshooting, 55
 Water spray deflector, 52

Squeegee position lamp, 13

Squeegee switch, 15

Squeegees, 56–58
 Blade deflection, 56, 60
 Deflection, 20
 Leveling, 57
 Rear, 56–58
 Replacing rear blades, 57–59
 Replacing side blades, 56
 Side, 56
 Switch, 15

SRS cleaning solution flow knob, 16

SRS liquid low level lamps, 16

SRS metering solution pump, 55

SRS solution tank, 54

SRS water spray deflector, 53

Steering, Machine specifications, 65

Steering wheel, 14

Storing machine, 26

Suspension, Machine specifications, 66

Switches
 Hazard light switch, 14
 Ignition, 13
 Operating lights switch, 14
 Rotating light switch, 14
 Squeegee, 15
 Throttle switch, 16

T

- Tank drain lamp, 13
- Throttle lever, 16
- Throttle switch, 16
- Tie down location, 24
- Tires, 62, 63
- To adjust alternator and radiator fan belt, 47
- To adjust vacuum fan drive belt, 47
- To clean water trap, 40
- To drain and clean recovery tank and empty hopper, 19–21
- To fill solution tank, 18
- To replace air filter element, 38, 39
- To replace fuel filter – Continental engines, 40
- To replace fuel filter – Perkins engines, 41
- To scrub, 18
- To start machine, 17
- To stop machine, 20
- Towing and transporting machine, 23
- Towing machine, 23
- Towing the machine, 23
- Transporting machine, 23
- Transporting the machine, 23
- Travel speed, 67
- Troubleshooting, 21–23
 - Hydraulic components, 35
 - Solution system, 55
- Troubleshooting solution system, 55

V

- Vacuum fan drive belt, 47
- Vacuum fan shaft, 30
- Vacuum hoses, Check, 20
- Vacuum wand, 22

W

- Water separator/fuel filter – Cat engines, 41
- Water spray deflector, 52

