



# V-WD-24P

Wet/Dry Vacuum

Parts Manual

Model Part No.:  
1244346 V-WD-24P [120V]

**TennantTrue® Parts**

## North America



To view, print or download the  
parts manual, visit:

[www.tennantco.com/manuals](http://www.tennantco.com/manuals)

9018766  
Rev. 00 (03-2019)

Only use TENNANT Company supplied or equivalent parts.  
Parts and supplies may be ordered online, by phone or from any Tennant or Nobles  
Authorized Service Center or Distributor.

Before Ordering any parts or supplies, be sure to have the machine model number and  
serial number available.

**Tennant Company**  
PO Box 1452  
Minneapolis, MN 55440 USA  
Phone: (800) 553-8033  
[www.tennantco.com](http://www.tennantco.com)  
[www.nobles.com](http://www.nobles.com)

Specifications and parts are subject to change without notice.  
Copyright ©2019 TENNANT Company

# TABLE OF CONTENTS

HEAD ASSEMBLY .....	4
TANK ASSEMBLY .....	8
PUMP ASSEMBLY .....	10
ANTI-FOAM ASSEMBLY.....	11
STANDARD ACCESSORY TOOLS .....	11
OPTIONAL DRY VACUUM DUAL FILTRATION SYSTEM .....	12
OPTIONAL SQUEEGEE ATTACHMENT KIT .....	13
OPTIONAL SQUEEGEE ASSEMBLY .....	14
LABEL KIT .....	15
ELECTRICAL DIAGRAM .....	15

## Recommended Spare Parts

<b>CLEANING TOOL ACCESSORIES</b>	
KTRIO5786	WAND SET, VACUUM, TWO-PIECE
KTRIO5804	HANDLE, VACUUM HOSE
KTRIO5811	HOSE ASSY, VACUUM, 5M, Ø38 MM
1064520	TOOL, FLOOR, WET
<b>OPTIONAL DRY VACUUM DUAL FILTRATION SYSTEM</b>	
KTRIO5593	DRY DUAL FILTRATION SYSTEM
KTRIO5813	FILTER, CARTRIDGE [V-WD-24P]
KTRIO5845	RING, FASTENER, PLASTIC
N/A	FILTER HOLDER RING
N/A	DOUBLE FILTRATION SYSTEM
KTRIO5851	BAG, MICROFIBER [10 PACK]
KTRIO5608	KIT, TOOL, DRY, Ø38 mm
1064519	TOOL, FLOOR, DRY
KTRIO5821	TOOL, FLOOR, CARPET
<b>OPTIONAL SQUEEGEE SYSTEM</b>	
KTRIO5342	SQUEEGEE KIT, VACUUM, WITH BRACKET
KTRIO5783	BLADE SET, SQGE
KTRIO5667	HOSE KIT, SQUEEGEE
KTRIO5784	KNOB SET, SQGE, YELLOW
KTRIO5714	WHEEL KIT, SQGE, WALL ROLLER
KTRIO5715	WHEEL KIT, SQGE, FLOOR SUPPORT
KTRIO5716	CLAMP KIT, SQUEEGEE
<b>GENERAL MAINTENANCE PARTS</b>	
KTRIO5657	CASTER KIT, VACUUM [QTY 2]
KTRIO5615	CORD KIT, POWER, PIGTAIL, 120VAC, YEL
KTRIO5351	CORD KIT, POWER, WITH CORD RESTRAINT
KTRIO5850	FLOAT KIT, VACUUM, BASKET
KTRIO5606	LATCH KIT, VACUUM [QTY 2]
KTRIO5619	MOTOR KIT, VACUUM, 1000W, 120V/60HZ
KTRIO5810	PUMP, DISCHARGE, 120V
1021709	SWITCH [ANTI-SPLASH, RED LIGHT]
KTRIO5809	SWITCH [ANTI-SPLASH, GREEN LIGHT]
KTRIO5660	HOSE KIT, DRAIN , W/CAP
KTRIO2728	CLIP KIT, HANDLE, D.25
KTRIO5769	CLIP KIT, DRAIN HOSE
KTRIO5645	FITTING KIT, HOSE CONNECTOR

# HEAD ASSEMBLY

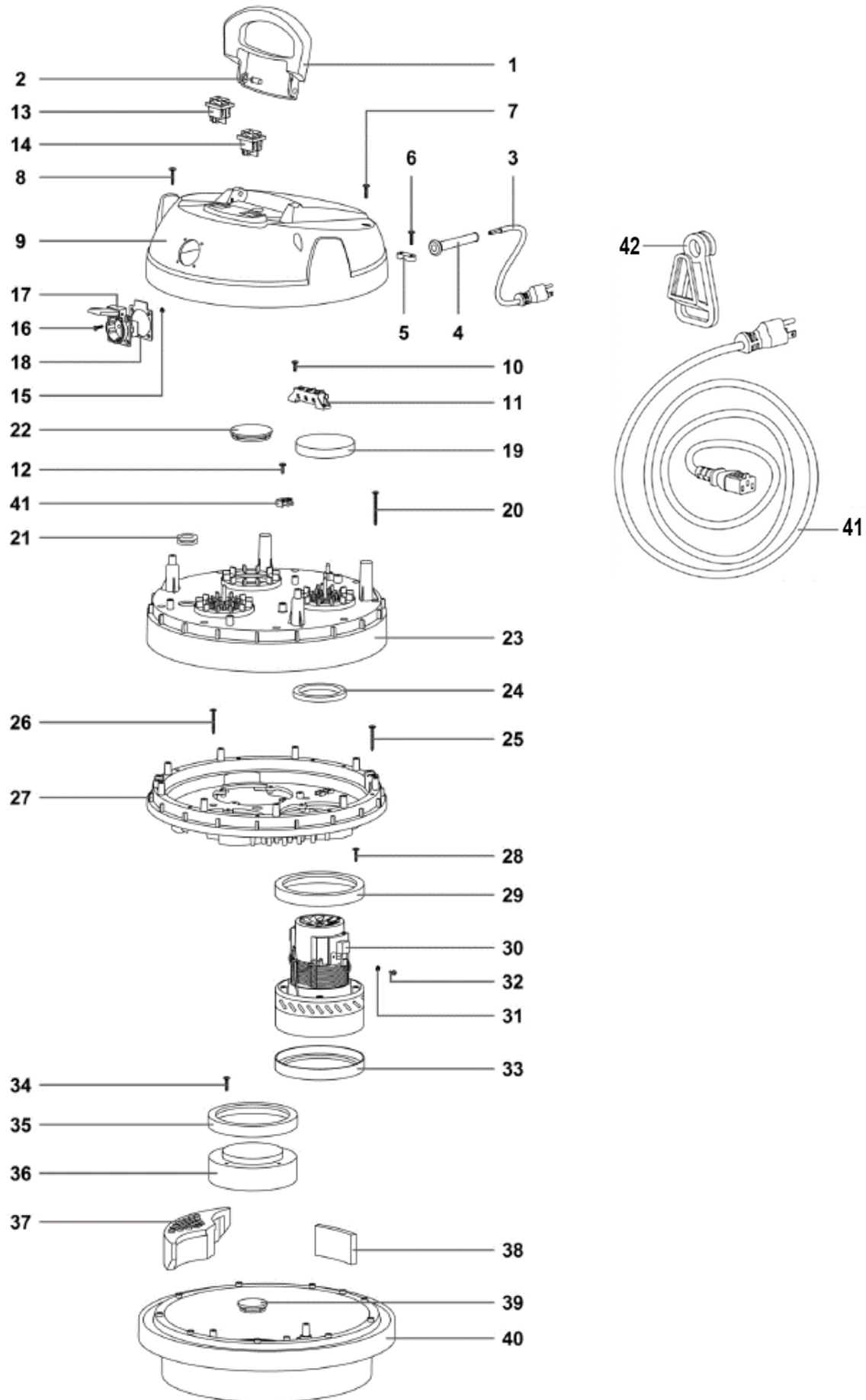

## HEAD ASSEMBLY

Code	Part No.	Description	Qty
▽	KTRIO5720	HOUSING ASSY, POWER, HEAD [V-WD-24P]	
▲ ▽	KTRIO5609	COVER KIT, VACUUM, GRAY	
▲ ▲ 1	N/A	HANDLE VEGAS G55 AUTOEST.	1
▲ ▲ 2	N/A	HANDLE PIN VEGAS	2
▲ ▲ 7	1021628	SCREW PFU TMT PHL 5X20 BLACK	2
▲ ▲ 8	N/A	SCREW PFU TMT PHL 5X25 ZN BLACK	2
▲ ▲ 9	N/A	COVER VEGAS 600 G55 AU 2INT.+PS	1
▲ ▽	KTRIO5615	CORD KIT, POWER, PIGTAIL, 120VAC, YELLOW	
▲ 3	N/A	POWER CORD 3X14AWG SJTW MT0,4 GI N5-	1
▲ 4	N/A	FAIR-LEAD LONG	1
▲ 5	1021626	CABLE CLAMP	1
▲ 6	1021628	SCREW PFU TMT PHL 5X20 BLACK	1
▲ ▽	KTRIO5616	TERMINAL KIT, VACUUM, W/WIRES	
▲ ▲ 10	1021706	SCREW PAT TMT PHL 5X14 ZN BLACK	2
▲ ▲ 11	N/A	CLAMP 400-600 3P 2MOT 14AWG S/R	1
▲ ▲ NS	N/A	CONN WIRE C.AWG-14 350-RO-FF-SP9	1
▲ ▲ NS	N/A	CONN. WIRE C.AWG-14 350-GR-FF-SP9	1
▲ ▲ NS	N/A	CAVETTO M.AWG-14 350-G/V-FF-SP9	1
▲ ▲ NS	N/A	CAVETTO M.AWG-14 350-G/V-FF-FF	1
▲ ▲ NS	N/A	WIRING (NOT SHOWN)	1
▲ 13	1021709	SWITCH [ANTI-SPLASH, RED LIGHT]	1
▲ 14	KTRIO5809	SWITCH [ANTI-SPLASH, GREEN LIGHT]	1
▲ ▽	KTRIO5617	RECEPTACLE KIT	
▲ ▲ 15	N/A	NUT M 4 UNI 5588	4
▲ ▲ 16	N/A	SCREW TSP CROSS M 4X12 UNI 7688	4
▲ ▲ 17	N/A	DOOR UL W/DOOR	1
▲ ▲ 18	N/A	SCHUKO GASKET SOCKET	1
▲ 19	1021647	FILTER, FOAM	1
▲ 12	1021706	SCREW PAT TMT PHL 5X14 ZN BLACK	1
▲ 20	N/A	SCREW PAT TMT PHL 5X55 ZN BLACK	9
▲ 21	1021711	GUIDING SLIT FOR QUICK COUPLING	1
▲ 22	N/A	CAP COVER SELF-EXTINGUISHING	2
▲ 23	N/A	COVERING 600 AU NERO	1
▲ 41	N/A	CLAMP W/FASTON	1
▲ 24	N/A	WASHER H8 D85X65	1
▲ 25	1021714	SCREW PAT TMT PHL 5X40 BLACK	9
▲ 26	1021714	SCREW PAT TMT PHL 5X40 BLACK	3
▲ 27	N/A	MOTOR FASTENER NEV. 600 AU NERO	1
▲ 28	N/A	SCREW PFU TMT PHL 5X20 BLACK	4

▽ KIT

▲ INCLUDED IN KIT

N/A = NOT AVAILABLE SEPARATELY - MUST ORDER KIT

# HEAD ASSEMBLY - Continued

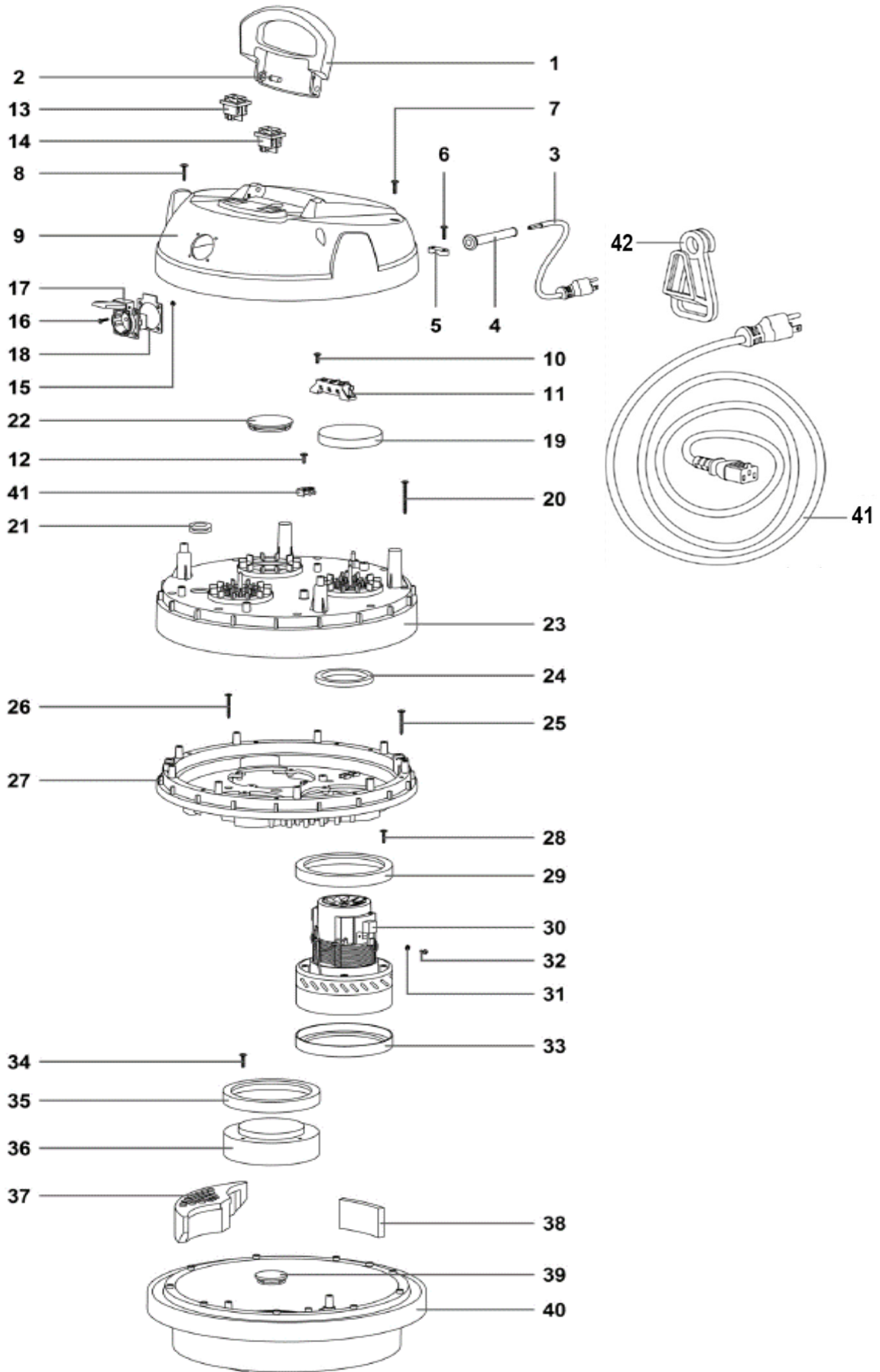

## HEAD ASSEMBLY - Continued

Code	Part No.	Description	Qty
▲ ▽	KTRI05618	GASKET KIT, MOTOR, 120VAC	1
▲ ▲ 29	1021657	"L" GASKET W/O HOLES H=5,5	1
▲ ▲ 33	1021657	"L" GASKET W/O HOLES H=5,5	1
▲ ▲ 34	1021628	SCREW PFU TMT PHL 5X20 BLACK	8
▲ ▲ 35	1021657	"L" GASKET W/O HOLES H=5,5	2
▲ ▲ 36	N/A	FAKE MOTOR LOWERED AU	2
▲ ▽	KTRI05619	MOTOR KIT, VACUUM, 1000W, 120V/60HZ	1
▲ ▲ 30	N/A	MOTOR BD381 AU 1000W 120/60	1
▲ ▲ 31	N/A	TOOTHED WASHER M4 UNI 8842	1
▲ ▲ 32	N/A	SCREW TC CROSS M 4X8 UNI 7687	1
▲ ▲ NS	N/A	CONN.WIRE M.AWG-14 400-G/V-FF-4,2	1
▲ ▲ NS	N/A	CLAMP (NOT SHOWN)	1
▲ ▲ NS	N/A	CONN.WIRE 50CM MOTORE POKE-IN UL	1
▲ 37	1021720	DAMPER, SOUND [V14]	3
▲ ▽	KTRI05639	BASE, HOUSING KIT, GRAY [V-WD-24P]	1
▲ ▲ 38	1021721	GASKET MTP/30 AU-AD 50X10X85	3
▲ ▲ 39	1021723	BASE CAP	2
▲ ▲ 40	N/A	BASE 600/400 G55 AU. COMP.	1
▲ ▽	KTRI05351	CORD KIT, POWER, WITH CORD RESTRAINT	1
▲ 41	N/A	CORD, POWER, DETACHABLE	1
▲ 42	N/A	CORD RESTRAINT	1
▲ NS	N/A	LABEL, LOGO, 04.3L DUAL [TENNANT/NOBLES]	1
▲ NS	N/A	LABEL, WARNING PER UL	1
▲ NS	N/A	LABEL, WARNING, 5.9 A MAX	1
▲ NS	N/A	LABEL, WARNING SOCKET SWITCH	1
▲ NS	N/A	LABEL, SWITCH, VACUUM	1
▲ NS	N/A	LABEL, SWITCH, PUMP	1

▽ KIT

▲ INCLUDED IN KIT

N/A = NOT AVAILABLE SEPARATELY - MUST ORDER KIT

# TANK ASSEMBLY

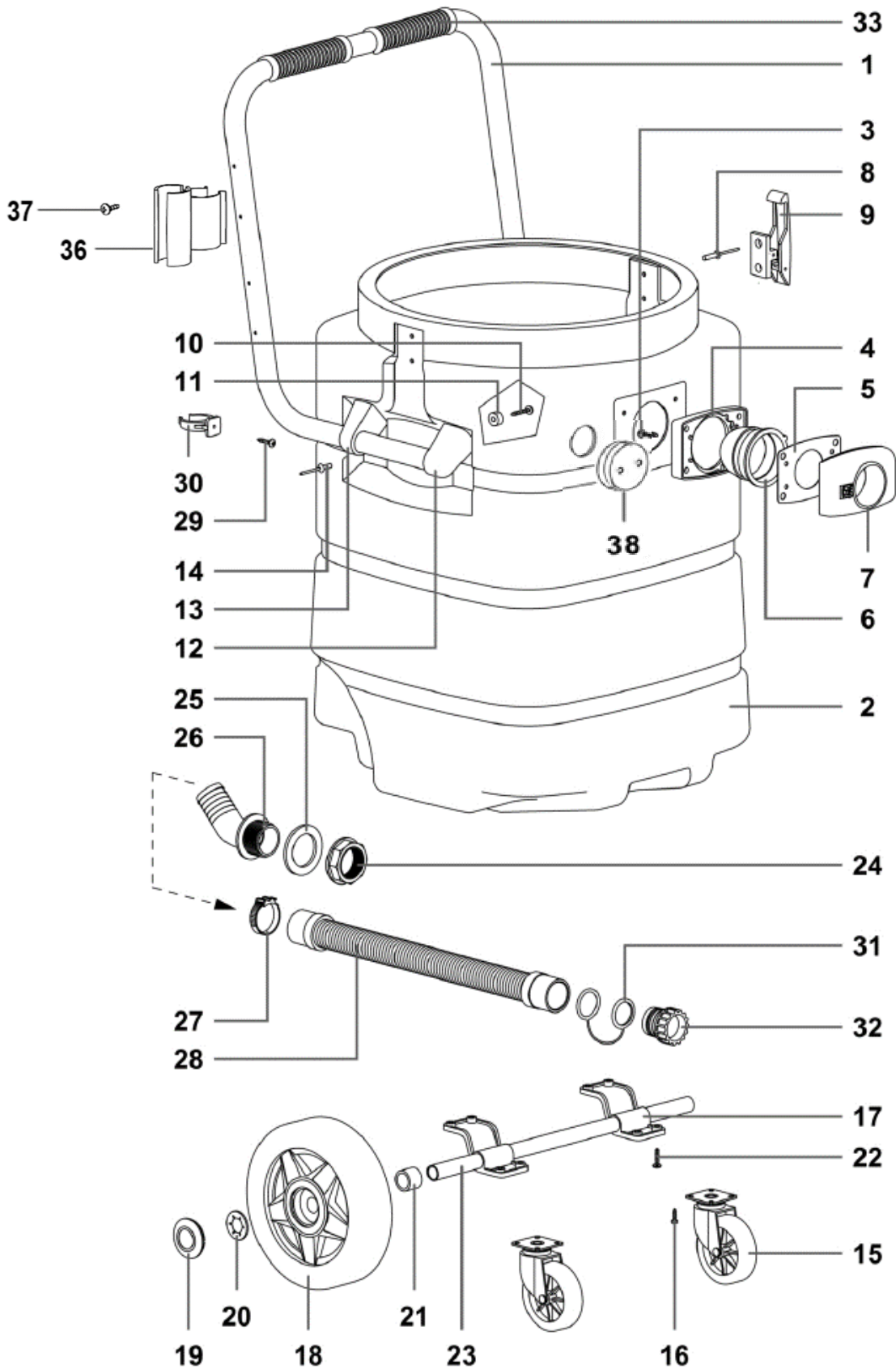



# TANK ASSEMBLY

Code	Part No.	Description	Qty		
▽	KTRIO5721	TANK KIT, VACUUM [V-WD-24P]	1		
▲	1	N/A	1		
▲	2	N/A	1		
▲	▽	KTRIO5656	FITTING KIT, HOSE, INLET	1	
▲	▲	3	1021640	SCREW PAT TMT PHL 5X30 BLACK	4
▲	▲	4	N/A	GASKET 99 BLACK	1
▲	▲	5	1021675	GASKET D.38	1
▲	▲	6	1021685	DEFLECTOR 99	1
▲	▲	7	N/A	PIPE UNION R155 NERO C/PUL.GI-VAC	1
▲	▽	KTRIO5606	LATCH KIT, VACUUM [QTY 2]	1	
▲	▲	8	1021673	RIVET 5X24,5	4
▲	▲	9	N/A	HOOK PLAST.COMPL. GI-VAC	2
▲		10	1021640	SCREW PAT TMT PHL 5X30 BLACK	8
▲		11	N/A	PLAST.WASHER	8
▲		12	N/A	HANDLE SUPPORT	2
▲		13	N/A	HANDLE SUPPORT PASSING	2
▲		14	N/A	RIVET 4,8X17 BLACK	2
▲		33	1021755	GRIP, TROLLEY HANDLE [QTY 2]	2
▲	▽	KTRIO5657	CASTER KIT, VACUUM [QTY 2]	1	
▲	▲	15	1021754	FLANGED WHEEL D.80	2
▲	▲	16	N/A	SCREW TC POZ 4X15 AC ZN BLACK	8
▲	▽	KTRIO5728	AXLE KIT	1	
▲	▲	17	N/A	SUPPORT WHEEL PIN	2
▲	▲	18	N/A	REAR WHEEL D.200	2
▲	▲	19	1021750	PLUG [V14]	2
▲	▲	20	N/A	BLOC. D.18	2
▲	▲	21	N/A	WHEEL SPACER MARK.PLAST.	2
▲	▲	22	1021628	SCREW	8
▲	▲	23	N/A	PIVOT WHEEL MARK.PLAST.TANK	1
▲	▽	KTRIO5659	FITTING KIT, DRAIN	1	
▲	▲	24	N/A	RING 1-1/4"	1
▲	▲	25	N/A	GASKET 60X40X4	1
▲	▲	26	N/A	FITTING CONNECTOR 45° 1-1/4"	1
▲	▽	KTRIO5660	HOSE KIT, DRAIN , W/CAP	1	
▲	▲	27	N/A	CLIP 300X9	1
▲	▲	28	N/A	DRAIN TUBE D.34 L=600	1
▲	▲	31	N/A	TIE ROD CAP	1
▲	▲	32	N/A	PLASTIC TOP D.40 X 35 W/OR COMPL.	1
▲	▽	KTRIO5769	CLIP KIT, DRAIN HOSE	1	
▲	▲	29	N/A	SCREW PAT TMT PHL 5X20 INOX	1
▲	▲	30	N/A	LIRA CLAMP D.34	1
▲	▽	KTRIO2728	CLIP KIT, HANDLE, D.25	1	
▲	▲	36	N/A	CLIP D36-38 BLACK	2
▲	▲	37	1021706	SCREW PAT TMT PHL 5X14 ZN BLACK	4
▲		38	N/A	FAIR-LEAD PER SUB 2 CAVI	1
▲	NS	N/A	N/A	LABEL, MODEL [V-WD-24P]	2
▲	NS	N/A	N/A	LABEL, WARNING, EN/FR/ES [AC W/D VAC]	1

▽ KIT

▲ INCLUDED IN KIT

N/A = NOT AVAILABLE SEPARATELY - MUST ORDER KIT

# PUMP ASSEMBLY

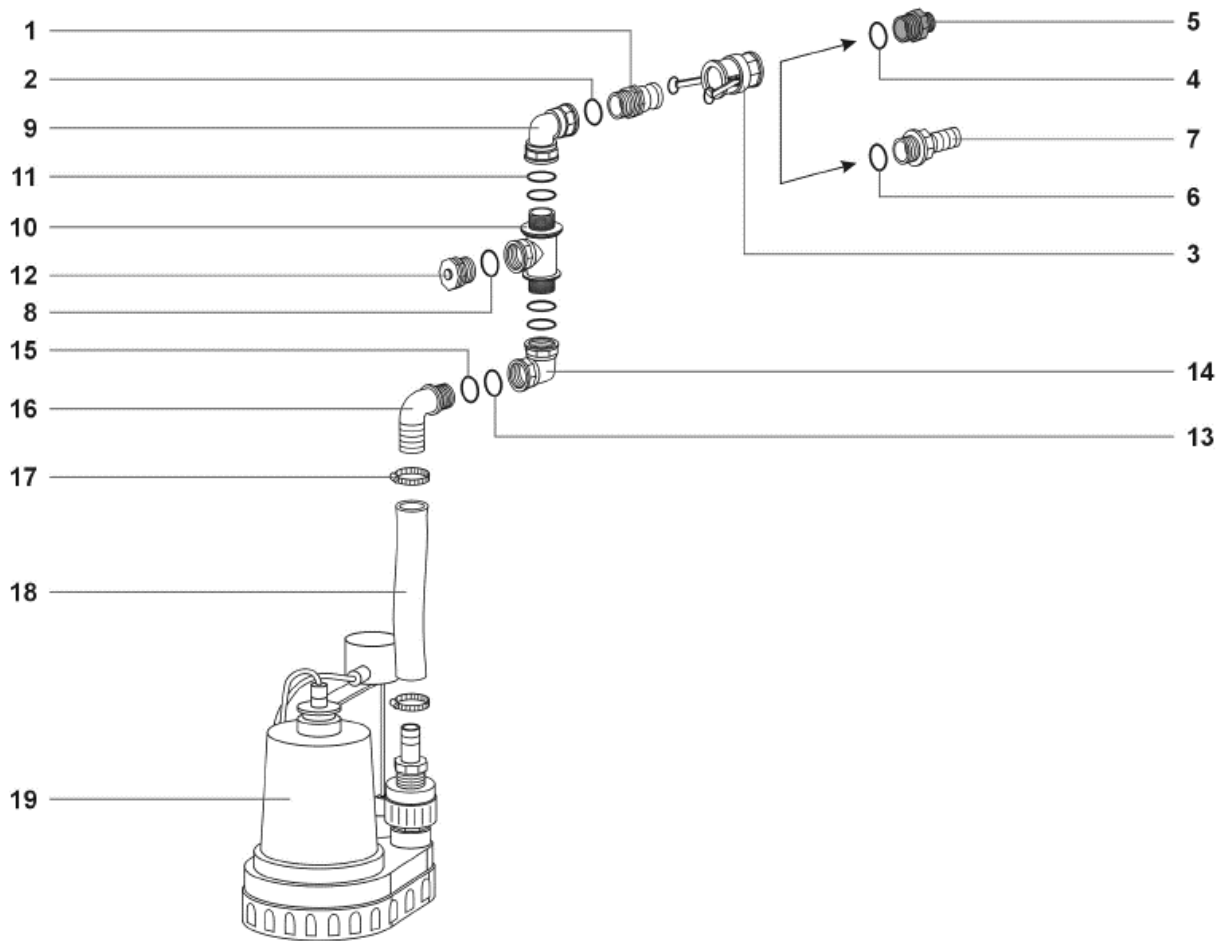

Code	Part No.	Description	QTY
▽	KTRIO5644	FITTING KIT, DISCHARGE	1
▲ 1	N/A	ADAPTER RACC. RAPIDO A CAMME 1" -	1
▲ 2	N/A	O-RING 3118 EPDM (2,62X 29,82)	1
▲ 3	N/A	CONNECTOR RAPIDO PLAST. A CAMME 1"	1
▽	KTRIO5645	FITTING KIT, HOSE CONNECTOR	1
▲ 4	N/A	O-RING 3118 EPDM (2,62X 29,82)	1
▲ 5	N/A	NIPPLE OTT. 1"GAS M. - 3/4"GHT M	1
▲ 6	N/A	O-RING 3118 EPDM (2,62X 29,82)	1
▲ 7	N/A	CONNECTOR PLAST. DIRITTO 1"M - P/GO	1
▽	KTRIO5646	TUBE KIT, DISCHARGE	1
▲ 8	N/A	O-RING 3118 EPDM (2,62X 29,82)	1
▲ 9	N/A	CONNECTOR PLAST. CURVO 90° 1"F - 1"	1
▲ 10	N/A	CONNECTOR PLAST. A T 1"F- 1"M -1"M	1
▲ 11	N/A	O-RING 3118 EPDM (2,62X 29,82)	4
▲ 12	N/A	CAP PLAST 1"M	1
▲ 13	N/A	O-RING 3118 EPDM (2,62X 29,82)	1
▲ 14	N/A	CONNECTOR PLAST. CURVO 90° 1"F - 1"	1
▲ 15	N/A	O-RING 3118 EPDM (2,62X 29,82)	1
▲ 16	N/A	CONNECTOR PLAST. CURVO 90° 1"M-P/G	1
▲ 17	N/A	CABLE TIE 25X45	2
▲ 18	N/A	ANTIFREEZE TUBE D.30 PER METER	1
▲ 19	KTRIO5810	PUMP, DISCHARGE, 120V	1

▽ KIT

▲ INCLUDED IN KIT

N/A = NOT AVAILABLE SEPARATELY - MUST ORDER KIT

## ANTI-FOAM ASSEMBLY

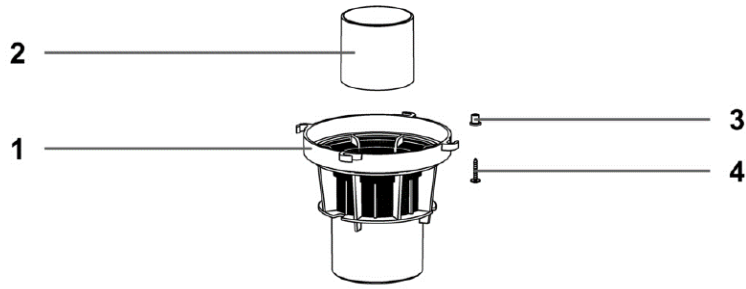

Code	Part No.	Description	QTY
▽	KRTI05850	FLOAT KIT, VACUUM, BASKET	1
▲ 1	N/A	NET ANTIFOAM BODY HIGH	1
▲ 2	N/A	HIGH FLOAT 99 W/GASKET 37 SHA	1
▲ 3	N/A	PLASTIC SLEEVE D.8	4
▲ 4	N/A	SCREW PAT TMT PHL 5X25	4

▽ KIT

▲ INCLUDED IN KIT

N/A = NOT AVAILABLE SEPARATELY - MUST ORDER KIT

## STANDARD ACCESSORY TOOLS

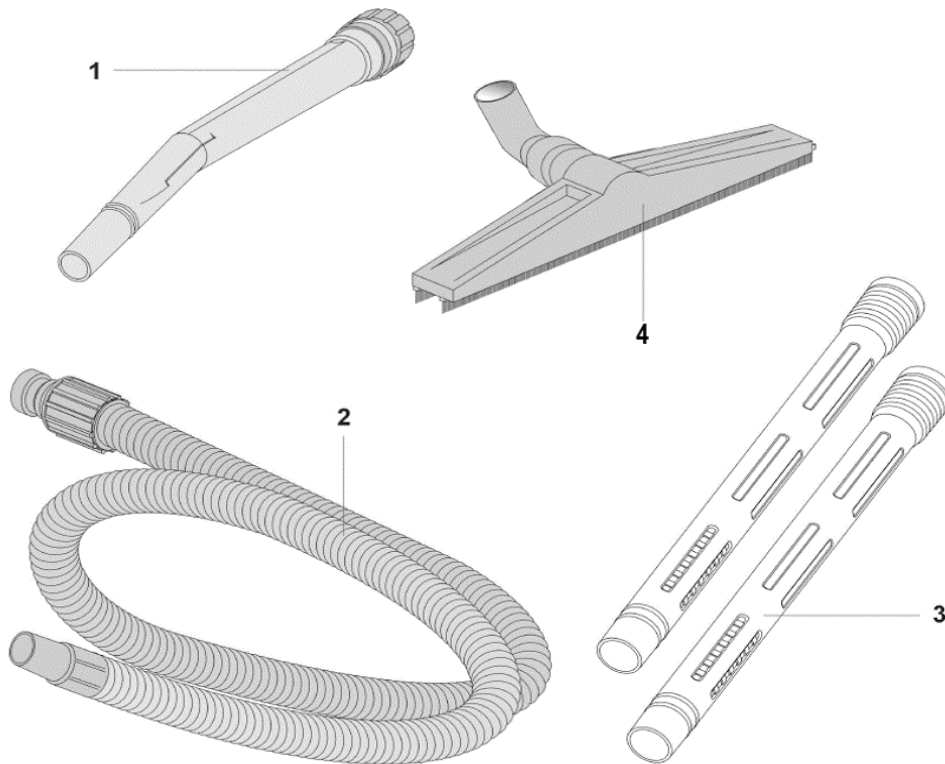

Code	Part No.	Description	QTY
1	KTRI05804	HANDLE, VACUUM HOSE	1
2	KTRI05811	HOSE ASSY, VACUUM, 5M, Ø38 MM	1
3	KTRI05786	WAND SET, VACUUM, TWO-PIECE	2
4	1064520	TOOL, FLOOR, WET	1

▽ KIT

▲ INCLUDED IN KIT

N/A = NOT AVAILABLE SEPARATELY - MUST ORDER KIT

## OPTIONAL DRY VACUUM DUAL FILTRATION SYSTEM

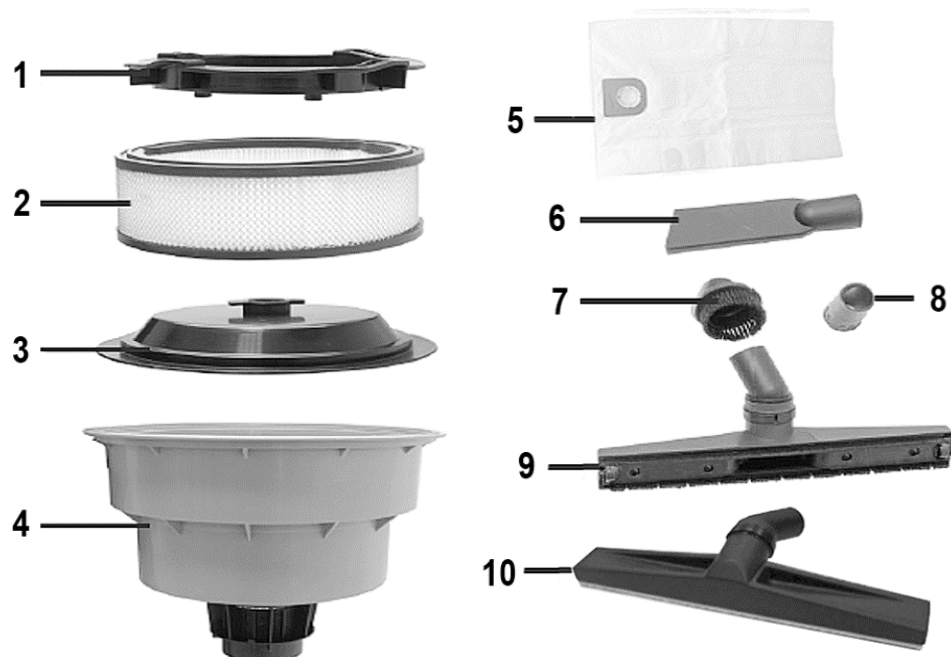

Code	Part No.	Description	Qty	
▽	KTRIO5593	FILTER KIT, DRY, DUAL FILTRATION SYS		
▲	1	N/A	1	
▲	2	KTRIO5813	FILTER, CARTRIDGE [V-WD-24P]	1
▲	3	KTRIO5845	RING, FASTENER, PLASTIC	1
▲	4	N/A	DOUBLE FILTRATION SYSTEM	1
▲	5	KTRIO5851	BAG, MICROFIBER [10 PACK]	1
▲ ▽	KTRIO5608	TOOL KIT, VACUUM, DRY [Ø38 MM]		
▲ ▲	6	1021757	FLAT LANCE D.38	1
▲ ▲	7	1021758	ROUND TOOL D.38	1
▲ ▲	8	1064521	PVC ADAPTOR D.38	1
▲	9	1064519	TOOL, FLOOR, DRY	1
▲	10	KTRIO5821	TOOL, FLOOR, CARPET	1

▽ KIT

▲ INCLUDED IN KIT

N/A = NOT AVAILABLE SEPARATELY - MUST ORDER KIT

# OPTIONAL SQUEEGEE ATTACHMENT KIT

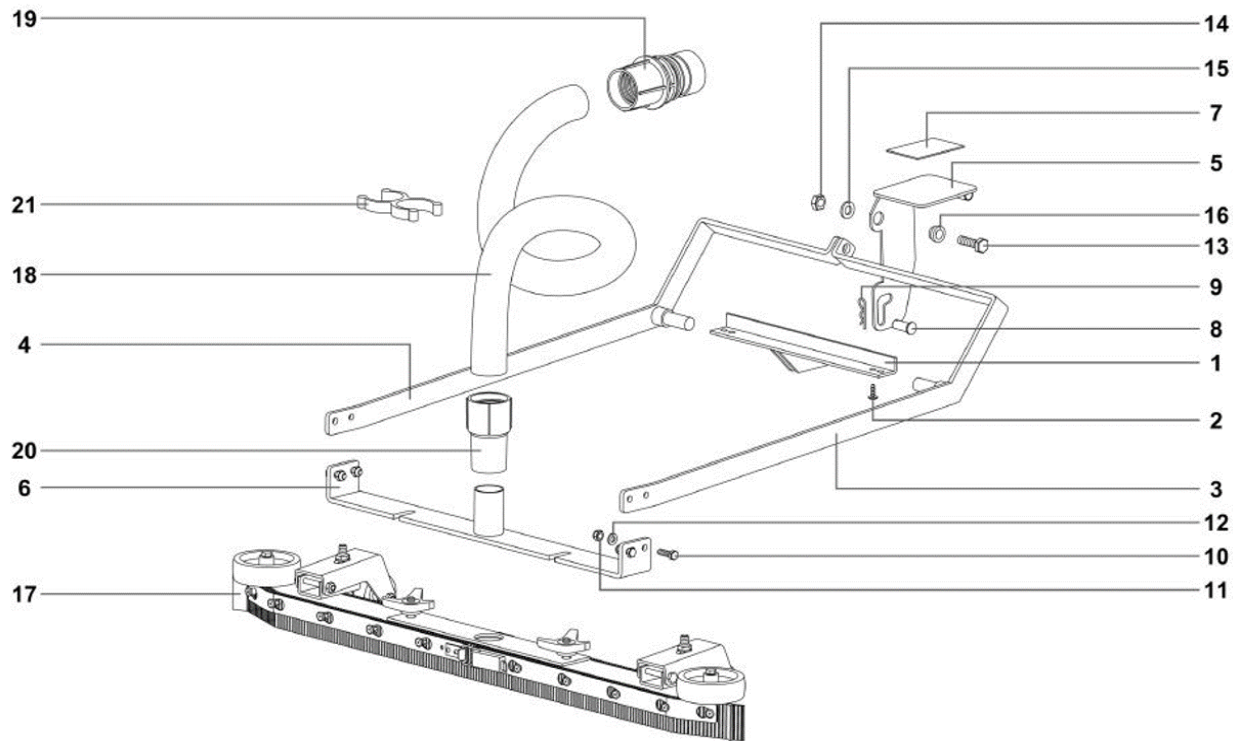

Code	Part No.	Description	Qty	
▽	KTRI05342	SQUEEGEE KIT, VACUUM, WITH BRACKET	1	
▲ ▽	KTRI05665	PEDAL KIT, SQGE	1	
▲ ▲ 1	N/A	SUPPORT PEDALE SQUEEGEE	1	
▲ ▲ 2	N/A	SCREW PAT TMT PHL 5X14 ZN BLACK	4	
▲ ▲ 5	N/A	PEDAL SQUEEGEE	1	
▲ ▲ 7	N/A	LABEL ADESIVA ANTISCIVOLO	1	
▲ ▲ 8	N/A	PIN DIA 10X30	1	
▲ ▲ 9	N/A	SPLIT PIN "R" D. 2 X 43 ZC	1	
▲ ▲ 13	N/A	SCREW TE M 10X30 UNI 5739	1	
▲ ▲ 14	N/A	SELF-LOCJ.NUT M10 SMALL UNI7474	1	
▲ ▲ 15	N/A	WASHER M 10	1	
▲ ▲ 16	N/A	SPACER SQUEEGEE 18X14X10	1	
▲ ▽	KTRI05666	BRACKET KIT, SQGE	1	
▲ ▲ 3	N/A	SHEET METAL PA. DX SISTEMA SOLLEVAMENTO	1	
▲ ▲ 4	N/A	SHEET METAL PA. SX SISTEMA SOLLEVAMENTO	1	
▲ ▲ 6	N/A	PLATE ANTERIORE SISTEMA SOLLEVA	1	
▲ ▲ 10	N/A	SCREW TE M 6X20 INOX UNI 5739	4	
▲ ▲ 11	N/A	SELFLOCKING NUT M 5 HIGH DIN 982	4	
▲ ▲ 12	N/A	STEEL WASHER M6	4	
▲ ▽	KTRI05667	HOSE KIT, SQUEEGEE	1	
▲ ▲ 18	N/A	FLEXIBLE HOSE 32 NERO MT.1 TYPE 3	1	
▲ ▲ 19	N/A	SLEEVE D.38/32 T.FLEX D.32 C/OR	1	
▲ ▲ 20	N/A	CUFF FOR "Y" CONNECTOR	1	
▲ ▲ 21	N/A	CLIP SIFONE TUBOFLEX 36	1	
▲	17	KTRI05812	SQUEEGEE KIT, VACUUM, 75CM	1
▲	NS	N/A	DOUBLE SCREWDRIVER	1

▽ KIT

▲ INCLUDED IN KIT

N/A = NOT AVAILABLE SEPARATELY - MUST ORDER KIT

# OPTIONAL SQUEEGEE ASSEMBLY

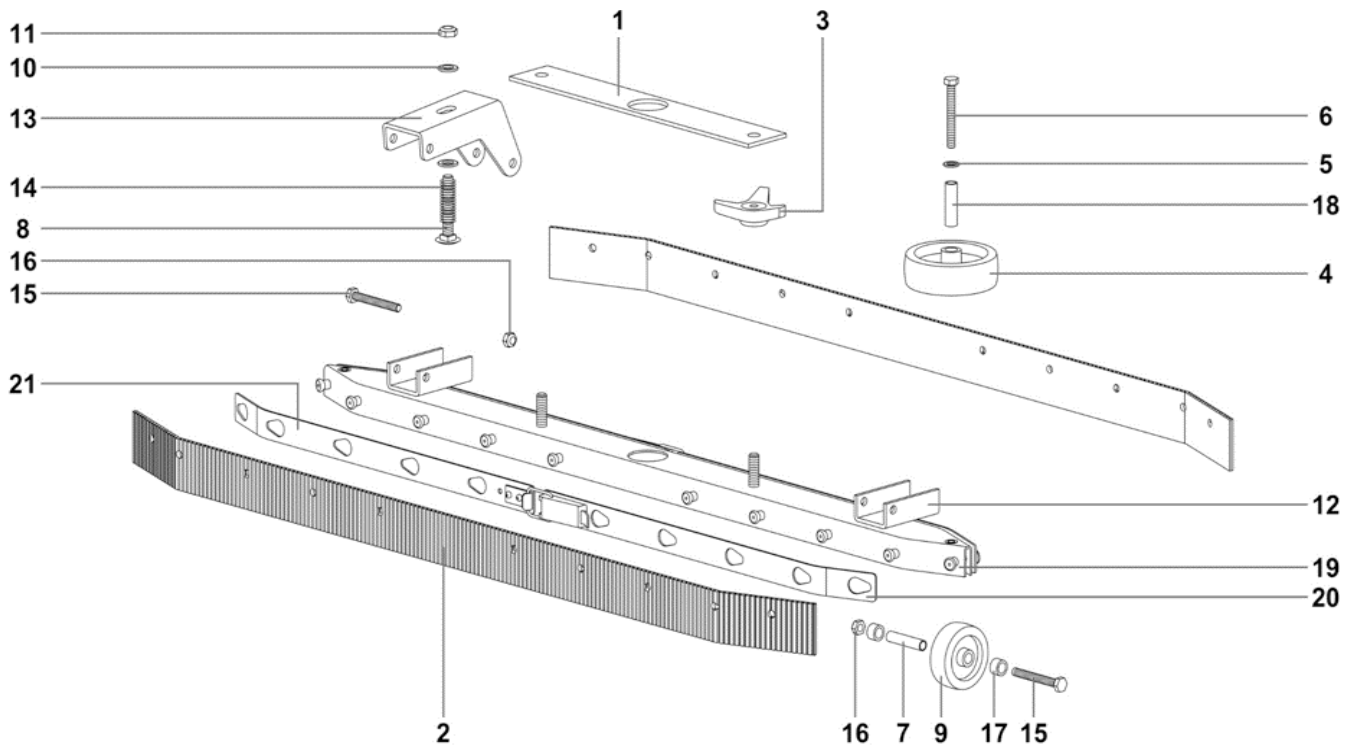

Code	Part No.	Description	Qty
▽	KTRIO5812	SQUEEGEE KIT, VACUUM, 75CM	1
▲	1	N/A GASKET ADHESIVE	1
▲	2	KTRIO5783 BLADE SET, SQGE	2
▲	3	KTRIO5784 KNOB SET, SQGE, YELLOW	2
▲ ▽	KTRIO5714	WHEEL KIT, SQGE, WALL ROLLER	1
▲ ▲	4	N/A WHEEL PLAST DIA 75 MOZZO 10	2
▲ ▲	5	N/A STEEL WASHER M6	2
▲ ▲	6	N/A SCREW TE M 6X 50 INOX A2	2
▲ ▲	18	N/A TUBE DISTANZIALE DIA10X30	2
▲ ▽	KTRIO5715	WHEEL KIT, SQGE, FLOOR SUPPORT	2
▲ ▲	7	N/A SPACER -	2
▲ ▲	8	N/A SCREW 50X10	2
▲ ▲	9	N/A WHEEL D. 50 FOR WET TOOL	2
▲ ▲	10	N/A WASHER D. 8 INX UNI 6592	4
▲ ▲	11	N/A SELF-LOCJ.NUT M 8 SMALL UNI 7474	2
▲ ▲	12	N/A BRACKET SUPP.RUOTINO SQUEEGEE	2
▲ ▲	13	N/A SUPPORT RUOTINO	2
▲ ▲	14	N/A SPRING D.15X 45 X1	2
▲ ▲	15	N/A SCREW TE M 6X 50 INOX A2	4
▲ ▲	16	N/A SELF-LOCJ.NUT M 6 SMALL UNI 7474	4
▲ ▲	17	N/A SPACER PLASTIC D.10 D.6,3X20	4
▲	19	N/A BODY SPAZZOLA SQUEEGEE	1
▲ ▽	KTRIO5716	CLAMP KIT, SQGE	1
▲ ▲	20	N/A CLAMP VENTOSA SQUEEGEE C/GANCIO	2
▲ ▲	21	N/A CLAMP VENTOSA SQUEEGEE C/STAFFA	2

▽ KIT

▲ INCLUDED IN KIT

N/A = NOT AVAILABLE SEPARATELY - MUST ORDER KIT

# LABEL KIT



**4** **WARNING:** To reduce the risk of electric shock always install float before any wet pick-up operation  
**AVERTISSEMENT:** pour réduire les risques de choc électrique, installer un flotteur avant des matières humides  
**WARNING:** To reduce the risk of electric shock use indoors only  
**AVERTISSEMENT:** pour réduire les risques de choc électrique, utiliser seulement à l'intérieur.



Code	Part No.	Description	QTY
▽	KTRIO5663	LABEL KIT,VACUUM [V-WD-24P]	1
▲	1	N/A LABEL, LOGO, DUAL [TENNANT/NOBLES]	1
▲	2	N/A LABEL, MODEL [V-WD-24P]	2
▲	3	N/A LABEL, WARNING, EN/FR/ES	1
▲	4	N/A LABEL, WARNING PER UL	1

▽ KIT

▲ INCLUDED IN KIT

N/A = NOT AVAILABLE SEPARATELY - MUST ORDER KIT

# ELECTRICAL DIAGRAM

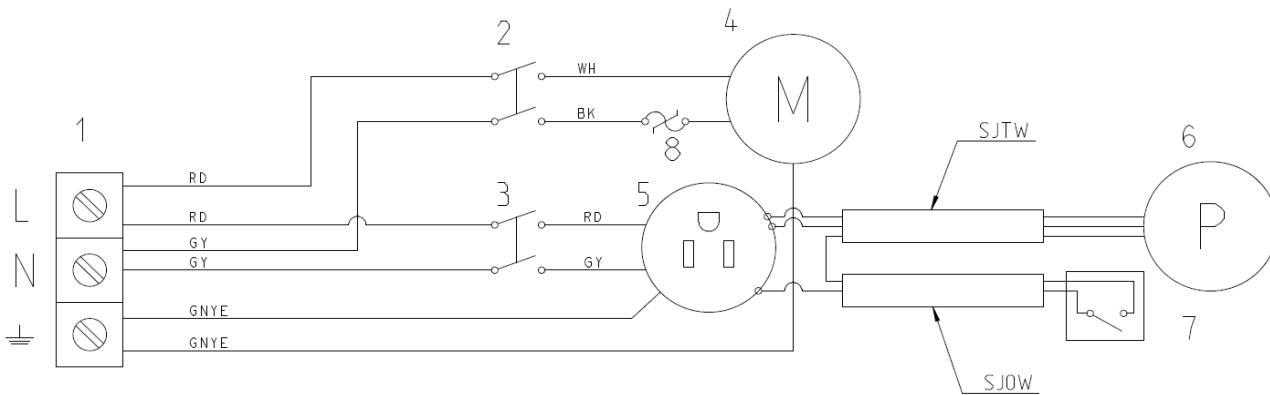

n°	Component description
1	Mains terminal block
2	Motor switch
3	Socket switch
4	Motor
5	Socket
6	Pump
7	Magnetic float switch
8	Thermal amperometric motor protector