

V-WD-9

Wet/Dry Vacuum

Parts Manual

Model Part No.:
1244345 V-WD-9 [120V]

TennantTrue® Parts

North America



To view, print or download the
parts manual, visit:

www.tennantco.com/manuals

9018765
Rev. 00 (03-2019)

Only use TENNANT Company supplied or equivalent parts.
Parts and supplies may be ordered online, by phone or from any Tennant or Nobles
Authorized Service Center or Distributor.

Before Ordering any parts or supplies, be sure to have the machine model number and
serial number available.

Tennant Company
PO Box 1452
Minneapolis, MN 55440 USA
Phone: (800) 553-8033
www.tennantco.com
www.nobles.com

Specifications and parts are subject to change without notice.
Copyright ©2019 TENNANT Company

TABLE OF CONTENTS

HEAD ASSEMBLY	4
TANK ASSEMBLY	6
MAIN FILTER ASSEMBLY	7
VACUUM BAGS AND FILTERS	7
ACCESSORY TOOLS	8
LABEL KIT	8
ELECTRICAL DIAGRAM	9

RECOMMENDED SPARE PARTS LIST

VACUUM BAGS AND FILTERS	
KTRIO5849	FILTER KIT, VACUUM, MAIN
KTRIO5847	BAG, VACUUM, PAPER [1 PKG = 10 BAGS]
KTRIO5848	BAG, VACUUM, MICROFIBER [1 PKG=10 BAGS]
KTRIO5800	FILTER, VACUUM, PRE-FILTER
KTRIO5808	FILTER KIT, CATRIDGE, HEPA W/RING & GASKET
KTRIO5839	RING, FASTENER, PLASTIC
KTRIO5801	FILTER, CARTRIDGE, HEPA
CLEANING TOOL ACCESSORIES	
KTRIO5804	HANDLE, VACUUM HOSE W/ REG, Ø38 MM
KTRIO5803	HOSE ASSY, VACUUM, 2.5M, Ø38 MM
KTRIO5786	WAND SET, VACUUM, TWO-PIECE
1064519	TOOL, FLOOR, DRY, Ø38 MM
1064520	TOOL, FLOOR, WET, Ø38 MM
KTRIO5608	TOOL KIT, VACUUM, Ø38 MM
GENERAL MAINTENANCE PARTS	
KTRIO5607	CASTER KIT, VACUUM [QTY 6]
KTRIO5850	FLOAT KIT, BASKET
KTRIO5606	LATCH KIT, VACUUM [QTY 2]
KTRIO5596	CORD KIT, POWER, 120VAC
KTRIO5599	MOTOR KIT, VACUUM, 1000W, 120V/60HZ
1021646	SWITCH, ON/OFF

HEAD ASSEMBLY

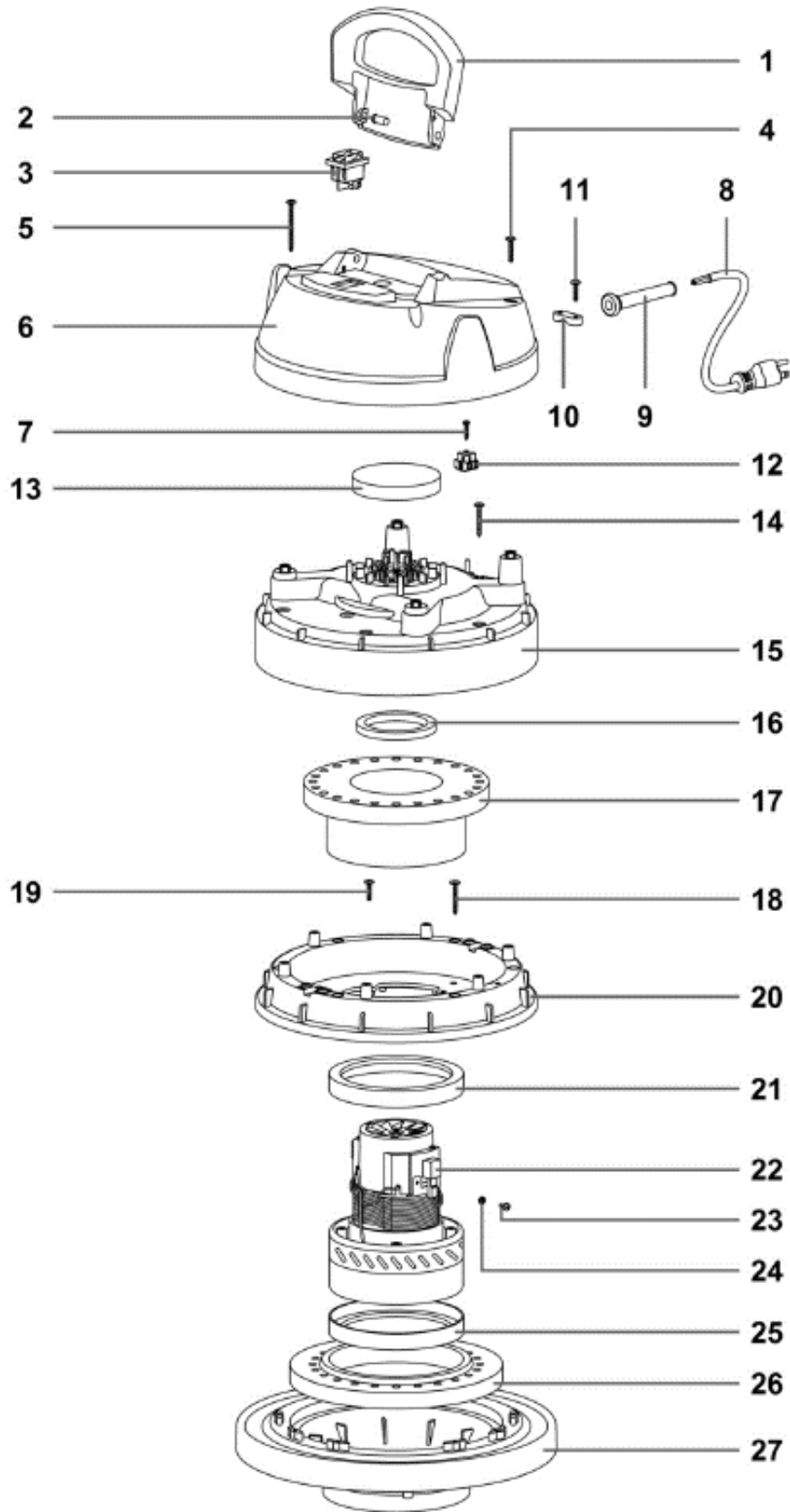

HEAD ASSEMBLY

Code	Part No.	Description	QTY
▽	KTRI05719	HOUSING ASSY, POWER, HEAD [V-WD-9]	1
▲ ▽	KTRI05595	COVER KIT, VACUUM, GRAY	1
▲ ▲ 1	N/A	HANDLE VEGAS G55 AUTOEST.	1
▲ ▲ 2	N/A	HANDLE PIN VEGAS	2
▲ 3	1021646	SWITCH [DEL-MM V10/V12]	1
▲ ▲ 4	N/A	SCREW PFU TMT PHL 5X25 ZN BLACK	2
▲ ▲ 5	N/A	SCREW PAT TMT PHL 5X55 BLACK	2
▲ ▲ 6	N/A	COVER VEGAS 500 G5500 AUTOEST.	1
▲ ▽	KTRI05612	TERMINAL KIT, VACUUM, W/WIRES	1
▲ ▲ 7	N/A	SCREW VITE TC PZ 4,2X16 ZN NERA	1
▲ ▲ 12	N/A	TERMINAL BOARD (Includes gray and red wires)	1
▲ ▽	KTRI05596	CORD KIT, POWER, 120VAC	1
▲ ▲ 8	N/A	ELECTRIC CORD 3X16 AWG	1
▲ ▲ 9	N/A	FAIR-LEAD LONG	1
▲ ▲ 10	1021626	BLOCK, STRAINRELIEF [V10/V12/V14]	1
▲ ▲ 11	1021628	SCREW [V10/V12/V14]	1
▲ 13	1021647	FILTER [V10/V12/V14]	1
▲ 14	1021648	SCREW [V10/V12/V14]	6
▲ 15	N/A	BLACK COVER 99 W/O/HOLES AU.	1
▲ 16	1021651	RING [V10/V12/V14]	1
▲ 18	1021648	SCREW [V10/V12/V14]	6
▲ 19	1021628	SCREW [V10/V12/V14]	4
▲ 20	N/A	MOTOR FASTENER 500 AU. NERO	1
▲ ▽	KTRI05599	MOTOR KIT, VACUUM, 1000W, 120V/60HZ	1
▲ ▲ NS	N/A	CONN.WIRE M.AWG-18 400-G/V-SP9- 4,2	1
▲ ▲ 22	N/A	MOTOR BD381 AU 1000W 120/60	1
▲ ▲ 23	N/A	SCREW TC CROSS M 4X8 UNI 7687	1
▲ ▲ 24	N/A	TOOTHED WASHER M4 UNI 8842	1
▲ ▲ NS	N/A	CLAMP (NOT SHOWN)	1
▲ ▲ NS	N/A	CONN.WIRE 40CM MOTOR POKE-IN UL	1
▲ ▽	KTRI05613	GASKET KIT, MOTOR, 120VAC	1
▲ ▲ 17	1021653	FILTER PHONO H=75	1
▲ ▲ 21	1021657	"L" GASKET W/O HOLES H=5,5	1
▲ ▲ 25	1021657	"L" GASKET W/O HOLES H=5,5	1
▲ ▲ 26	1021659	WASHER MTP 65MM 18D 230X145	1
▲ 27	KTRI05802	BASE, HOUSING, GRAY [V-WD-9]	1
▲ NS	N/A	LABEL, LOGO, DUAL [TENNANT/NOBLES]	1
▲ NS	N/A	LABEL, WARNING UL	1

▽ KIT

▲ INCLUDED IN KIT

N/A = NOT AVAILABLE SEPARATELY - MUST ORDER KIT

TANK ASSEMBLY

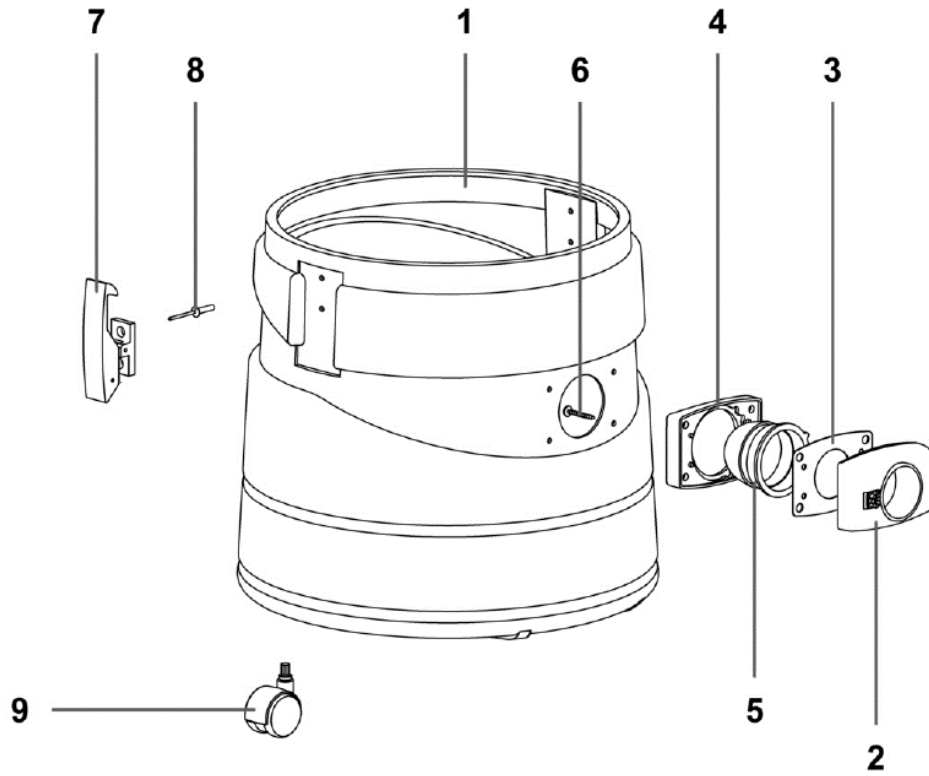

Code	Part No.	Description	QTY	
▽	KTRIO5611	TANK KIT, VACUUM, V-WD-9 [COMPLETE ASSY]	1	
▲	1	N/A	TANK 115 PLAST/SMALL BLACK	1
▲ ▽	KTRIO5614	FITTING KIT, HOSE, INLET	1	
▲ ▲	2	N/A	COMP.INLET R155 BLACK W/YELL.SWITCH	1
▲ ▲	3	1021675	GASKET D.38	1
▲ ▲	4	N/A	GASKET R 205 BLACK	1
▲ ▲	5	1021685	DEFLECTOR 99	1
▲ ▲	6	1021648	SCREW PAT TMT PHL 5X35 BLACK	4
▲ ▽	KTRIO5606	LATCH KIT, VACUUM [QTY 2]	1	
▲ ▲	7	N/A	HOOK PLAST.COMPL. GI-VAC	2
▲ ▲	8	1021673	RIVET 5X24,5	4
▲	9	KTRIO5607	CASTER KIT, VACUUM [QTY 6]	6
▲	NS	N/A	LABEL, MODEL [V-WD-9]	2
▲	NS	N/A	LABEL, WARNING, EN/FR/ES	1

▽ KIT

▲ INCLUDED IN KIT

N/A = NOT AVAILABLE SEPARATELY - MUST ORDER KIT

MAIN FILTER ASSEMBLY

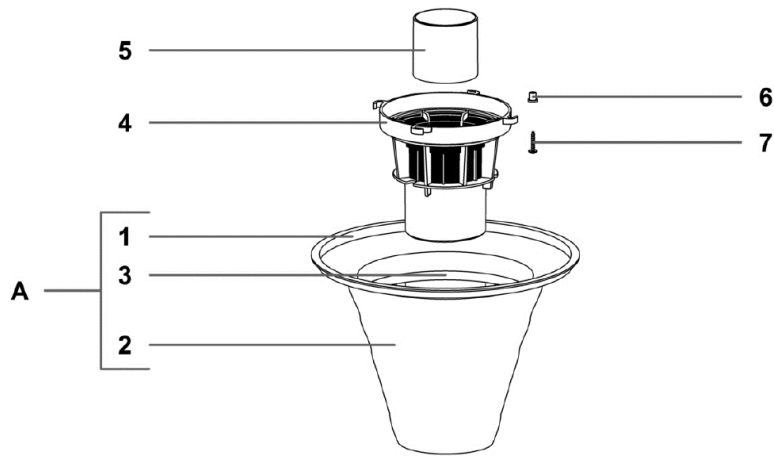

	Code	Part no.	Description	QTY
▽	A	KTRIO5849	FILTER KIT, VACUUM, MAIN	1
▲	1	N/A	FILTER RING 500	1
▲	2	N/A	FILTER POLY AN3-500 CON REG H230	1
▲	3	1021668	CONICAL BASKET 300	1
▽		KTRIO5850	FLOAT KIT, BASKET	1
▲	4	N/A	NET ANTIFOAM BODY HIGH	1
▲	5	N/A	HIGH FLOAT 99 W/GASKET 37 SHA	1
▲	6	N/A	PLASTIC SLEEVE D.8	4
▲	7	N/A	SCREW PAT TMT PHL 5X25	4

▽ KIT

▲ INCLUDED IN KIT

N/A = NOT AVAILABLE SEPARATELY - MUST ORDER KIT

VACUUM BAGS AND FILTERS

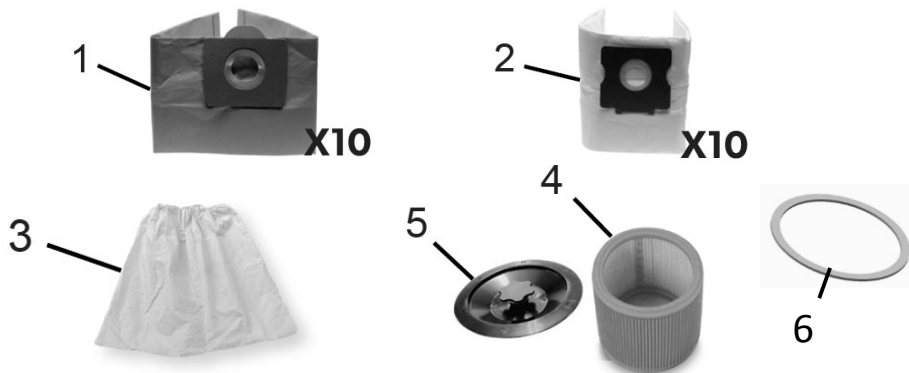

	Code	Part No.	Description	Qty
	1	KTRIO5847	BAG, VACUUM, PAPER [1 PKG = 10 BAGS]	1
	2	KTRIO5848	BAG, VACUUM, MICROFIBER [1 PKG=10 BAGS]	1
	3	KTRIO5800	FILTER, VACUUM, PRE-FILTER (OPTIONAL)	1
▽		KTRIO5808	FILTER KIT, CARTRIDGE, HEPA W/RING & GASKET (OPTIONAL)	1
▲	4	KTRIO5801	FILTER, CARTRIDGE, HEPA	1
▲	5	KTRIO5839	RING, FASTENER, PLASTIC	1
▲	6	N/A	GASKET H3	1

▽ KIT

▲ INCLUDED IN KIT

N/A = NOT AVAILABLE SEPARATELY - MUST ORDER KIT

ACCESSORY TOOLS

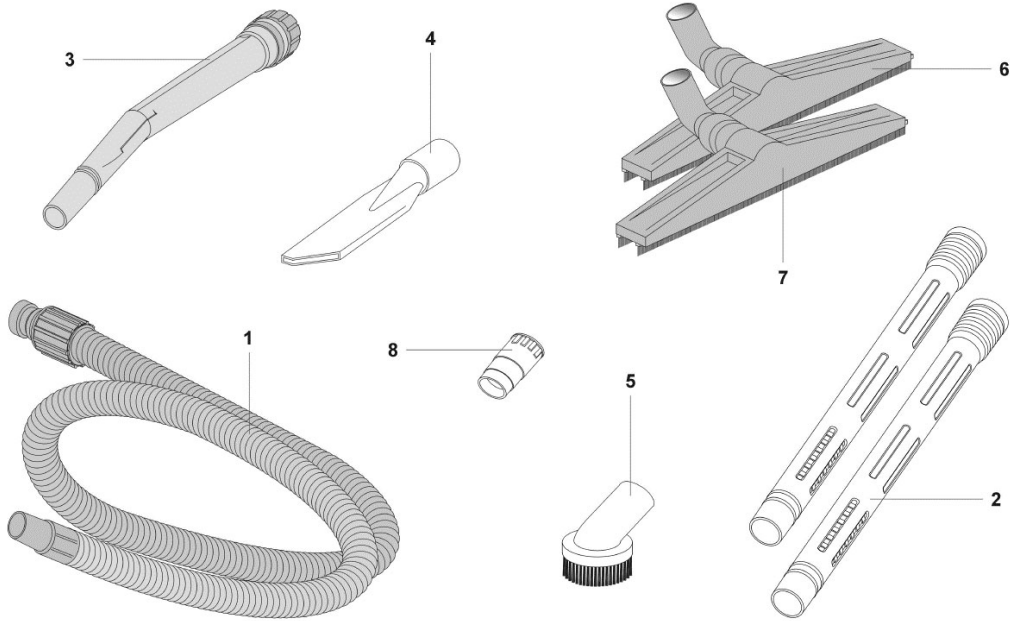

Code	Part No.	Description	QTY	
1	KTRIO5803	HOSE ASSY, VACUUM, 2.5M, Ø38 MM	1	
2	KTRIO5786	WAND SET, VACUUM, TWO-PIECE	2	
3	KTRIO5804	HANDLE, VACUUM HOSE W/ REG, Ø38 MM	1	
▽	KTRIO5608	TOOL KIT, VACUUM, Ø38 MM	1	
▲	4	1021757	FLAT LANCE D.38	1
▲	5	1021758	ROUND TOOL D.38 / small box	1
▲	8	1064521	PVC ADAPTOR D.38	1
	6	1064519	TOOL, FLOOR, DRY, Ø38 MM	1
	7	1064520	TOOL, FLOOR, WET, Ø38 MM	1
NS	KTRIO5821	TOOL, FLOOR, CARPET 38 MM (OPTIONAL)	1	

▲ INCLUDED IN KIT

N/A = NOT AVAILABLE SEPARATELY - MUST ORDER KIT

LABEL KIT

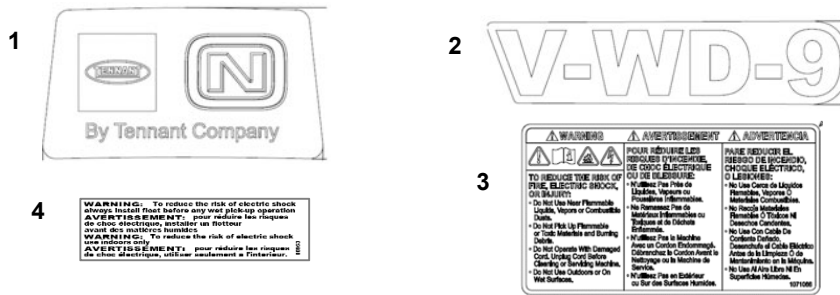

Code	Part No.	Description	QTY	
▽	KTRIO5610	LABEL KIT,VACUUM [V-WD-9]		
▲	1	N/A	LABEL, LOGO, DUAL [TENNANT/NOBLES]	1
▲	2	N/A	LABEL, MODEL [V-WD-9]	2
▲	3	N/A	LABEL, WARNING, EN/FR/ES	1
▲	4	N/A	LABEL, WARNING, UL	1

▽ KIT

▲ INCLUDED IN KIT

N/A = NOT AVAILABLE SEPARATELY - MUST ORDER KIT

ELECTRICAL DIAGRAM

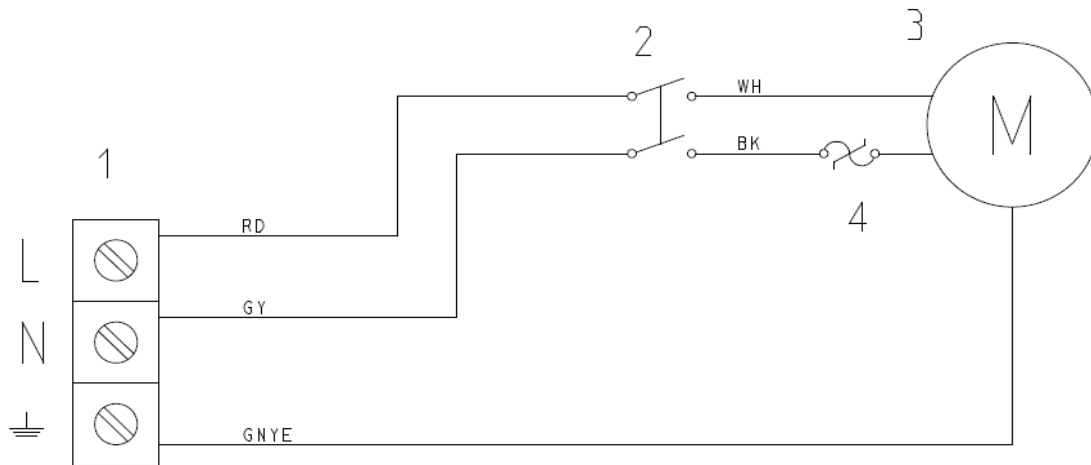

n°	Component description
1	Mains terminal block
2	Motor switch
3	Motor
4	Thermal amperometric motor protector