

SW5500

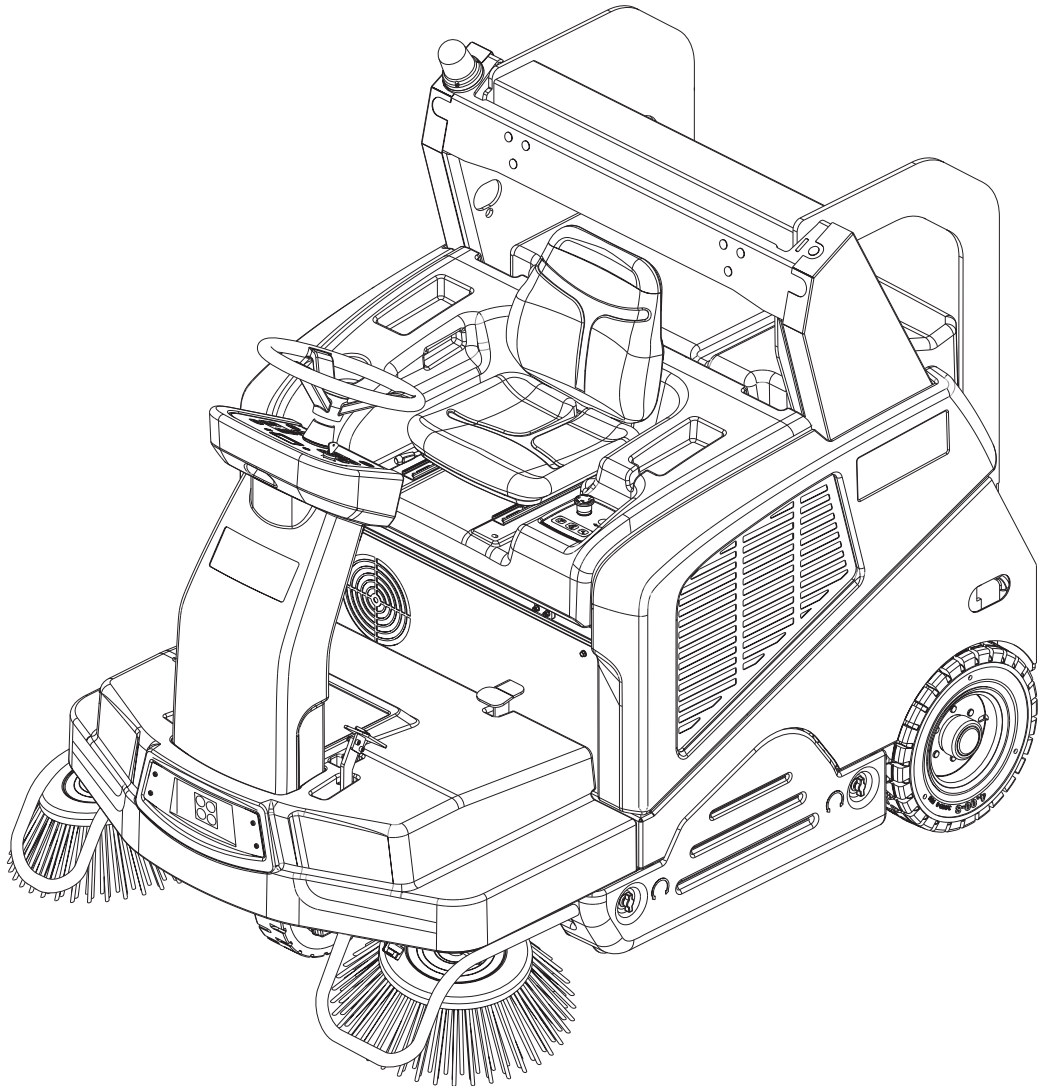

Instructions for Use - Original Instructions
Instrucciones de Uso
Instructions d'Utilisation
Instruções de Uso

Model: 9084417010



English
Español
Français
Português

09/2016
(1)

FORM NO. 1467287000

TABLE OF CONTENTS

INTRODUCTION	2
MANUAL PURPOSE AND CONTENTS	2
TARGET.....	2
HOW TO KEEP THIS MANUAL.....	2
IDENTIFICATION DATA.....	2
OTHER REFERENCE MANUALS.....	3
SPARE PARTS AND MAINTENANCE.....	3
CHANGES AND IMPROVEMENTS	3
OPERATION CAPABILITIES.....	3
CONVENTIONS	3
UNPACKING/DELIVERY	3
SAFETY	3
VISIBLE SYMBOLS ON THE MACHINE.....	4
SYMBOLS THAT APPEAR ON THIS MANUAL.....	4
GENERAL INSTRUCTIONS.....	4
MACHINE DESCRIPTION	8
MACHINE STRUCTURE	8
CONTROL PANEL	11
ACCESSORIES/OPTIONS.....	12
TECHNICAL DATA.....	12
WIRING DIAGRAM.....	14
USE	16
FUEL.....	16
BEFORE MACHINE START-UP	17
STARTING AND STOPPING THE MACHINE	17
PARKING BRAKE.....	18
MACHINE OPERATION	19
HOPPER DUMPING.....	20
AFTER USING THE MACHINE.....	21
MACHINE LONG INACTIVITY	21
MAINTENANCE	21
SCHEDULED MAINTENANCE TABLE	21
MULTIFUNCTION DISPLAY SERVICE SCREENS.....	23
MAIN BROOM HEIGHT CHECK AND ADJUSTMENT	25
MAIN BROOM REPLACEMENT	26
SIDE BROOM HEIGHT CHECK AND ADJUSTMENT	27
SIDE BROOM REPLACEMENT	28
PANEL DUST FILTER CLEANING AND INTEGRITY CHECK	29
SKIRT HEIGHT AND OPERATION CHECK.....	30
DUSTGUARD™ SYSTEM WATER FILTER CLEANING (OPTIONAL).....	31
HYDRAULIC SYSTEM OIL LEVEL CHECK.....	31
ENGINE OIL LEVEL CHECK AND REPLACEMENT	32
ENGINE AIR FILTER CHECK/CLEANING	33
ENGINE SPARK PLUG CHECK/REPLACEMENT	34
BATTERY CHARGING (only for version with optional hybrid KIT installed).....	35
FUSE CHECK/REPLACEMENT.....	36
SAFETY FUNCTIONS	36
EMERGENCY PUSH-BUTTON.....	36
DRIVER'S SEAT MICROSWITCH.....	36
ANTI-SKID SAFETY SYSTEM	36
MACHINE ANGLE SENSOR.....	36
HOPPER POSITION SENSOR	36
HOPPER SAFETY VALVE.....	36
TROUBLESHOOTING	37
SCRAPPING	38

INTRODUCTION



NOTE

The numbers in brackets refer to the components shown in Machine Description chapter.

MANUAL PURPOSE AND CONTENTS

The purpose of this Manual is to provide the operator with all necessary information to use the machine properly, in a safe and autonomous way. It contains information about technical data, safety, operation, storage, maintenance, spare parts and disposal. Before performing any procedure on the machine, the operators and qualified technicians must read this Manual carefully. Contact Advance in case of doubts regarding the interpretation of the instructions and for any further information.

TARGET

This Manual is intended for operators and technicians qualified to perform the machine maintenance. The operators must not perform procedures reserved for qualified technicians. Advance will not be responsible for damages coming from failure to follow these instructions.

HOW TO KEEP THIS MANUAL

The Instructions for Use Manual must be kept near the machine, inside an adequate case, away from liquids and other substances that can cause damage to it.

IDENTIFICATION DATA

The machine serial number and model name are marked on the plate (30).
 Product code and year of production are marked on the same plate.
 The engine model and serial number are shown on the engine plate (see the engine manual).
 This information is useful when ordering machine and engine spare parts. Use the following table to write down the machine and engine identification data for any further reference.

MACHINE model
PRODUCT code
MACHINE serial number
ENGINE model
ENGINE serial number

OTHER REFERENCE MANUALS

- Spare Parts List (supplied with the machine)
- Engine Manual (Honda iGX 270)
- Service Manual (that can be consulted at Advance Service Centers)

SPARE PARTS AND MAINTENANCE

All necessary operating, maintenance and repair procedures must be performed by qualified personnel or by Advance Service Centers. Only original spare parts and accessories must be used.

Contact Advance for service or to order spare parts and accessories, specifying the machine model, product code and serial number.

CHANGES AND IMPROVEMENTS

Advance constantly improves its products and reserves the right to make changes and improvements at its discretion without being obliged to apply such benefits to the machines that were previously sold.

Any change and/or addition of accessories must be approved and performed by Advance.

OPERATION CAPABILITIES

This sweeper has been approved to clean (sweeping and vacuuming) compact and solid floors, in commercial or industrial environments, under safe operation conditions by a qualified operator.

CONVENTIONS

Forward, backward, front, rear, left or right are intended with reference to the operator's position, that is to say on the driver's seat (3).

UNPACKING/DELIVERY



CAUTION!

To unpack the machine, carefully follow the instructions on the packing.

Upon delivery carefully check that the machine and its packing have not been damaged during transportation. In case of visible damages, keep the packing and have it checked by the carrier that delivered it. Call the carrier immediately to fill in a damage claim. Check that the machine is equipped with the following features:

- Technical documents:
 - Sweeper Instructions for Use Manual (this document)
 - Engine Manual (Honda iGX 270)
 - Sweeper Spare Parts List
- No. 1 10 A fuse

SAFETY

The following symbols indicate potentially dangerous situations. Always read this information carefully and take all necessary precautions to safeguard people and property.

The operator's cooperation is essential in order to prevent injury. No accident prevention program is effective without the total cooperation of the person responsible for the machine operation. Most of the accidents that may occur in a factory, while working or moving around, are caused by failure to comply with the simplest rules for exercising prudence. A careful and prudent operator is the best guarantee against accidents and is essential for successful completion of any prevention program.

VISIBLE SYMBOLS ON THE MACHINE

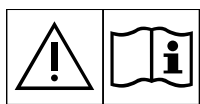

WARNING!
Carefully read all the instructions before performing any operation on the machine.

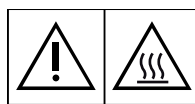

WARNING!
Hot parts, danger of burns.



DANGER!
Internal combustion engine. Do not inhale exhaust gas fumes. Carbon monoxide (CO) can cause brain damage or death.

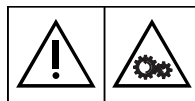

WARNING!
Moving parts.



WARNING!
Do not wash the machine with direct or pressurized water jets.

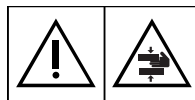

WARNING!
Moving parts. Danger of crushing.



WARNING!
Do not use the machine on slopes with a gradient exceeding the specifications.



WARNING!
Parts under voltage. Presence of corrosive fluids.

SYMBOLS THAT APPEAR ON THIS MANUAL



DANGER!
It indicates a dangerous situation with risk of death for the operator.



WARNING!
It indicates a potential risk of injury for people or damage to objects.



CAUTION!
It indicates a caution or a remark related to important or useful functions. Pay careful attention to the paragraphs marked by this symbol.



NOTE
It indicates a remark related to important or useful functions.



CONSULTATION
It indicates the necessity to refer to the Instructions for use Manual before performing any procedure.

GENERAL INSTRUCTIONS

Specific warnings and cautions to inform about potential damages to people and machine are shown below.



DANGER!

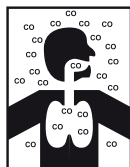

- Carbon monoxide (CO) can cause brain damage or death.
- The internal combustion engine of this machine can emit carbon monoxide.
- Do not inhale exhaust gas fumes.
- Only use indoors when adequate ventilation is provided, and with the help of an assistant who can monitor the operator's health.

**DANGER!**

- Before performing any maintenance, repair, cleaning or replacement procedure disconnect the batteries, remove the ignition key and engage the parking brake.
- This machine must be used by properly trained operators only.
- Sharp turns must be made in safe conditions. Avoid abrupt turns, particularly on slopes, and turns with the hopper lifted.
- Do not lift the hopper when the machine is on a slope.
- Keep the batteries away from sparks, flames and incandescent material.
- Do not wear jewels when working near electrical components.
- Do not work under the lifted machine without supporting it with safety stands.
- When working under the open hood, ensure that it cannot be closed by accident.
- Do not operate the machine near toxic, dangerous, flammable and/or explosive powders, liquids or vapors: This machine is not suitable for collecting dangerous powders.
- Be careful: fuel is highly flammable.
- Do not smoke or bring naked flames in the area where the machine is refueled or where the diesel fuel is stored.
- Refuel outdoors or in a well-ventilated area, with the engine off.
- Leave at least a space of 4 cm in the filler to allow the fuel to expand. After refueling, check that the fuel tank cap is firmly closed.
- If any fuel is spilled while refueling, clean the tank area and allow the vapors to evaporate before starting the engine.
- Do not let fuel come into contact with the skin; do not breathe fuel vapors. Keep out of reach of children.
- Do not tilt the engine or the machine too much to avoid fuel spillage.
- When moving the machine, the fuel tank must not be full and the fuel valve must be closed.
- Do not lay any object on the engine.
- Stop the engine before performing any procedure on it. To avoid any incidental start, disconnect the spark plug cap or disconnect the battery negative terminal.
- See also the SAFETY RULES in the Engine Manual, which is to be considered an integral part of this Manual.
- Lead batteries (WET) are installed on this machine, do not tilt the machine more than 30° from its horizontal position to prevent the highly corrosive acid to leak out of the batteries. When the machine is to be tilted to perform maintenance procedures, remove the batteries.
- Do not use the machine in case of gas leaks. Disconnect the hose and replace the LPG tank. If the gas leak persists, disconnect the hose and contact the Advance Service Center.

**WARNING!**

- Carefully read all the instructions before performing any maintenance/repair procedure.
- The machine must be regularly inspected by qualified personnel, especially the LPG tank and its connections to grant a safe use, as stated by the local laws in force.
- When working near the hydraulic system, always wear protective clothes and safety glasses.
- This machine is not intended for use by persons (including children) with reduced physical, sensory or mental capabilities, or lack of experience and knowledge, unless they have been given supervision or instruction concerning use of the machine by a person responsible for their safety. Children should be supervised to ensure that they do not play with the machine.
- Close attention is necessary when used near children.
- Use only as shown in this Manual. Use only Advance's recommended accessories.
- Check the machine carefully before each use, always check that all the components have been assembled before use. If the machine is not perfectly assembled it can cause damages to people and properties.
- Take all necessary precautions to prevent hair, jewels and loose clothes from being caught by the machine moving parts.
- To avoid any unauthorized use of the machine, remove the ignition key.
- Do not leave the machine unattended without being sure that it cannot move independently.
- The machine must be safely parked (considering the pressurized LPG on board).
- Do not use the machine on slopes with a gradient exceeding the specifications.

**WARNING!**

- Do not tilt the machine more than the angle indicated on the machine itself, in order to prevent instability.
- Use only brooms supplied with the machine or those specified in the Instructions for Use Manual. Using other brooms could reduce safety.
- This is a class A product. In a domestic environment this product may cause radio interference in which case the user may be required to take adequate measures.
- Before using the machine, close all doors and/or covers as shown in the Instructions for Use Manual.
- Do not wash the machine with direct or pressurized water jets, or with corrosive substances.
- Use the machine only where a proper lighting is provided.
- Working lights (optional) have to be used only to enhance visibility on the floor to be cleaned, but they do not authorize anyone to use the sweeper in dark environments.
- While using this machine, take care not to cause damage to people or objects.
- Do not bump into shelves or scaffoldings, especially where there is a risk of falling objects.
- If the proper protective guard (FOPS)(optional) is not installed, do not use the machines in areas where there is the risk of falling objects.
- Do not lean liquid containers on the machine, use the relevant can holder.
- The machine storage temperature must be +32 °F to 104 °F (0 °C to +40 °C).
- The machine working temperature must be +32 °F to 104 °F (0 °C to +40 °C).
- The humidity must be between 30 % and 95 %.
- Always protect the machine against the sun, rain and bad weather, both under operation and inactivity condition. Store the machine indoors, in a dry place. (If applicable) This machine must be used in dry conditions, it must not be used or kept outdoors in wet conditions.
- Do not use the machine as a means of transport, or for pushing/towing.
- The machine maximum capacity, operator's weight not included, is 529 lb (240 kg) (the weight of waste).
- In case of fire, use a powder fire extinguisher, not a water one.
- Adjust the operation speed to suit the floor conditions.
- Avoid sudden stops when the machine is going downhill. Avoid sharp turns. Drive at slow speed when going downhill.
- This machine cannot be used on roads or public streets.
- Do not tamper with the machine safety guards.
- Follow the routine maintenance procedures scrupulously.
- Do not allow any object to enter into the openings. Do not use the machine if the openings are clogged. Always keep the openings free from dust, hairs and any other foreign material which could reduce the air flow.
- (Only for versions equipped with DustGuard™ system). Pay attention during machine transportation when temperature is below freezing point. The water in the tank or in the hoses could freeze and seriously damage the machine.
- Do not remove or modify the plates affixed to the machine.
- When the machine is to be pushed for service reasons (lack of fuel, etc.), the speed must not exceed 4 km/h.
- In case of machine malfunctions, ensure that these are not due to lack of maintenance. If necessary, request assistance from the authorized personnel or from an authorized Service Center.
- If parts must be replaced, require ORIGINAL spare parts from an Authorized Dealer or Retailer.
- To ensure machine proper and safe operation, the scheduled maintenance shown in the relevant chapter of this Manual, must be performed by the authorized personnel or by an authorized Service Center.
- The machine must be disposed of properly, because of the presence of toxic-harmful materials (batteries, oils, etc.), which are subject to standards that require disposal in special centers (see the Scrapping chapter).
- While the engine is running, the silencer warms up; do not touch the silencer when it is hot to avoid burns or fires.
- Running the engine with an insufficient quantity of oil can seriously damage the engine. Check the oil level with the engine off and the machine on a level surface.
- Never run the engine if the air filter is not installed, because the engine could be damaged.
- Technical service procedures on the engine must be performed by an authorized Dealer. Only use original spare parts or parts of matching quality for the engine. Using spare parts of lower quality can seriously damage the engine.
- See also the SAFETY RULES in the Engine Manual, which is to be considered an integral part of this Manual.

Guide lines to bacteria control and other dangers coming from the presence of microbes in the DustGuard™ system (optional).



WARNING!

To prevent the operators and other people from developing infections caused by microbes and Legionella that may flourish in the dust guard system, take the following precautions:

- *If possible, fill the tank with cold water [$< 68\text{ }^{\circ}\text{F}$ ($< 20\text{ }^{\circ}\text{C}$)].*
- *DO NOT use stagnant water to fill the tank.*
- *DO NOT use recycled water, undrinkable water or water that has been in contact with the soil.*
- *Adjust and turn the nozzles towards the floor only, from preventing possible inhaling.*
- *Do not store the machine outdoors or near sources of heat.*
- *Do not over-fill the tank. Fill the tank sufficiently so that it can be emptied by using the system.*
- *Empty the tank every 10 hours or once a week, according to the use.*
- *If the machine is not used for more than one week, empty the tank completely, and let it dry before storing it.*
- *If the tank cannot be cleaned regularly, consider using a biocide that can kill or exert a controlling effect on Legionella bacteria. Biocide must be chosen according to the local regulations and must be used according to the relevant instructions and cautions, to avoid that the personnel gets affected by dangerous chemical substances.*
- *If chemical products have to be used in the water tank, it is mandatory to apply the relevant information and caution labels of the product.*

MACHINE DESCRIPTION

MACHINE STRUCTURE

1. Steering wheel
2. Control panel (see the following paragraph)
3. Driver's seat with safety microswitch
4. Seat position adjusting lever
5. Accelerator pedal
6. Service brake pedal
7. Parking brake lever: press both the service brake (6) and the lever (7) to switch from the service brake to the parking brake
8. Front skirt lifting pedal
9. Main broom height adjusting knob:
 - Turn it counter-clockwise to increase the broom pressure on the floor
 - Turn it clockwise to decrease the broom pressure on the floor
10. Vacuum system rear hood
11. Vacuum system hood release lever
12. Hopper (empty it when it is full)
13. Right door (to be opened for performing maintenance procedures only)
14. Left door (for main broom removal)
15. Right side broom
16. Left side broom (optional)
17. Side broom guards (optional)
18. Main broom
19. Engine compartment hood
20. Can holder
21. Rear wheels
22. Front driving and steering wheel
23. Dust filter container / Dust guard system water tank (optional)
24. Panel filter
25. Dust guard system water filler neck plug (optional)
26. Dust guard system nozzles (optional)
27. Front column
28. Working lights
29. Flashing light (always on when the ignition key is turned to "I")
30. Serial number/technical data/conformity certification plate
31. Removable right side panel
32. Removable left side panel
33. Anchoring slots for transport (not for lifting)
34. LPG cylinder
35. LPG tank fastening band
36. Engine off push-button (optional, only for hybrid version)

MACHINE STRUCTURE (Continues)

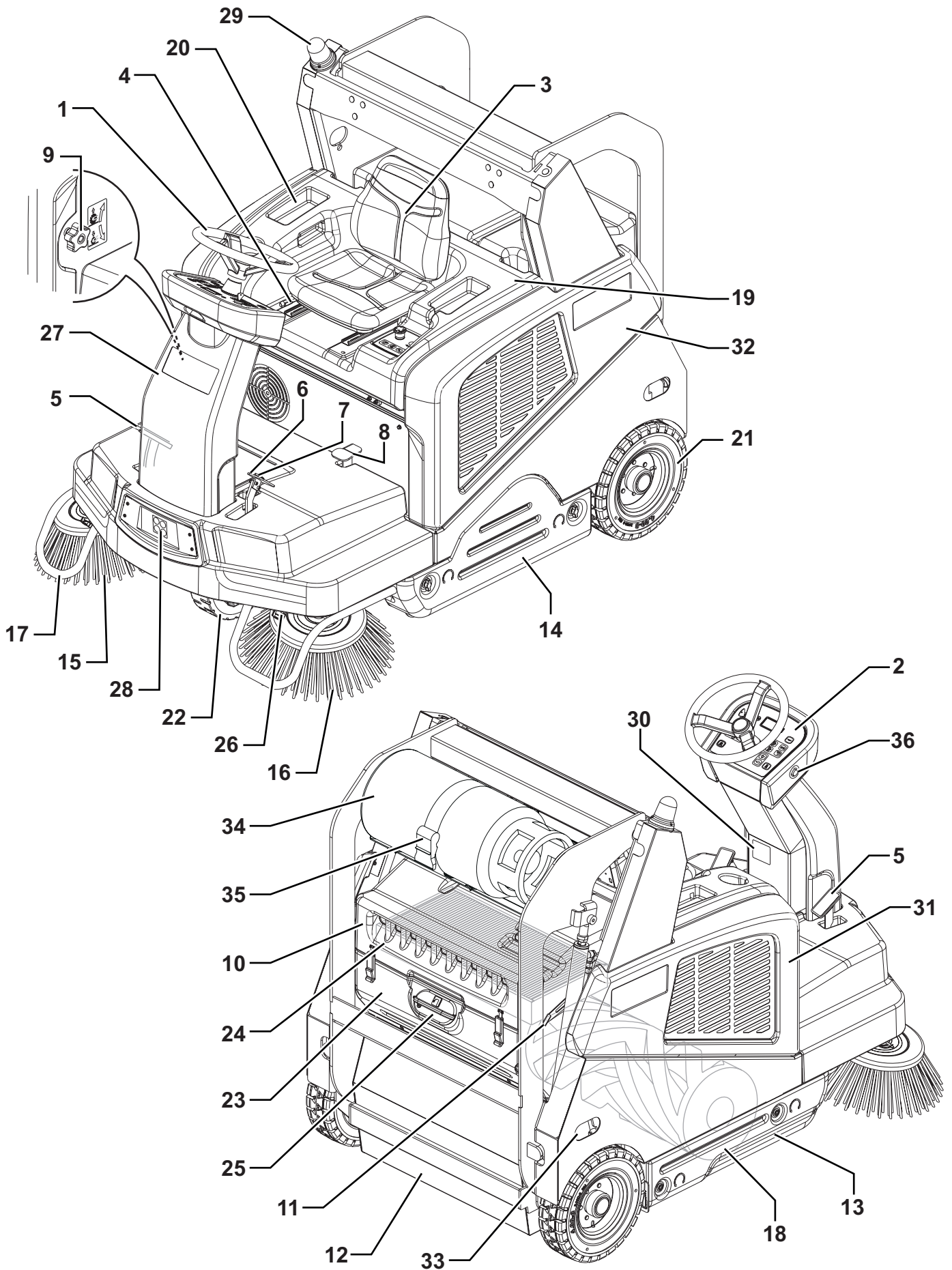

P100919

MACHINE STRUCTURE (Continues)

- | | |
|---|--------------------------|
| 41. Engine compartment hood (open) | 44. Open hood safety rod |
| 42. LPG engine | 45. Alternator |
| 43. Hydraulic unit with tank for hopper lifting | 46. Cooling fan |
| | 47. Batteries |

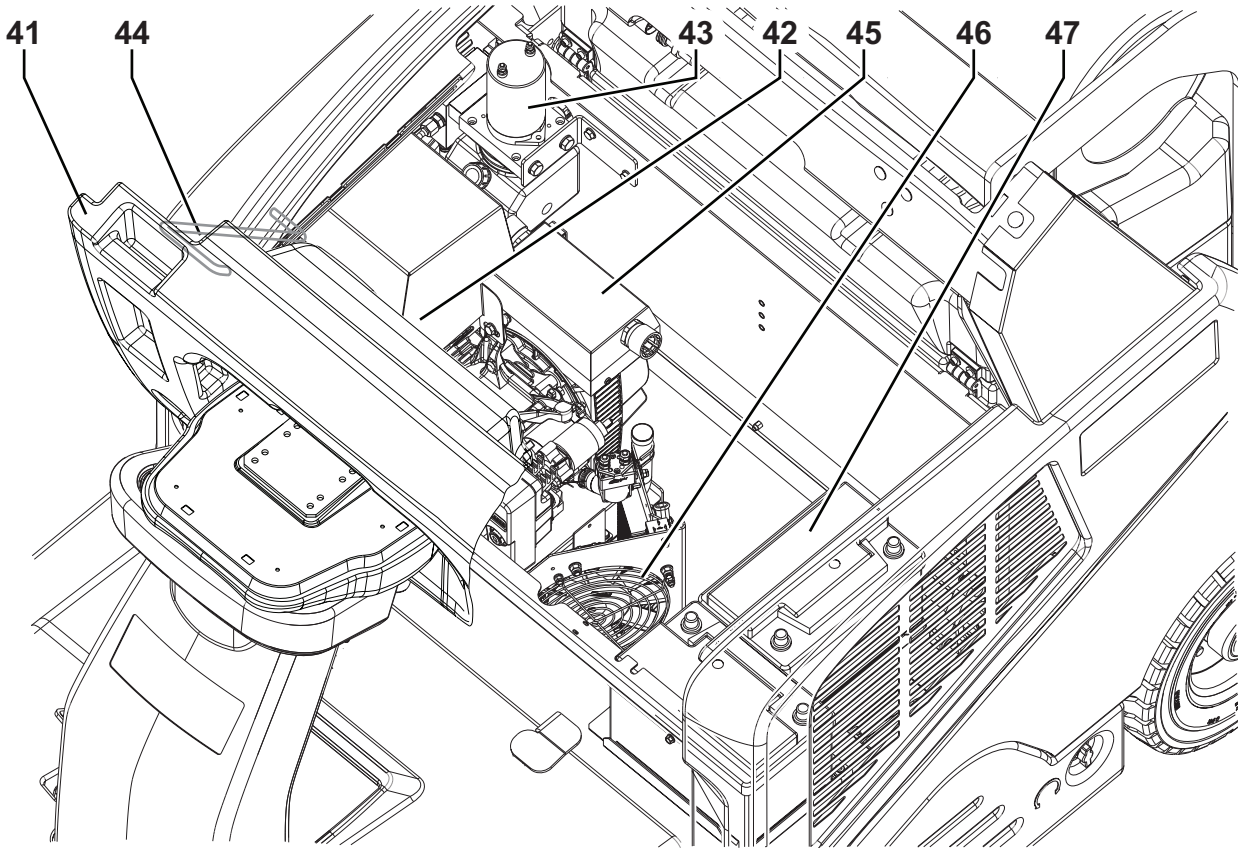

P100920

CONTROL PANEL

- 51. Ignition key:
 - When turned to “0”, it turns the electrical system off and disables all machine functions
 - When turned to “II”, it starts the machine. When the machine starts, release the key, which will return to “I” (machine ON)
- 52. One-Touch sweeping/vacuuming push-button
- 53. Right side broom push-button
- 54. Left side broom push-button
- 55. Side broom rotation speed adjustment push-buttons
- 56. Vacuum push-button
- 57. Filter shaker push-button
- 58. Increase maximum running speed push-button
- 59. Decrease maximum running speed push-button
- 60. Hopper lifting push-button
- 61. Hopper lowering push-button
- 62. Hopper dumping push-button
- 63. Hopper reset push-button
- 64. Reverse gear/forward gear reset push-button
- 65. Horn push-button
- 66. Hopper movement enabling push-button
- 67. Working light push-button (optional)
- 68. DustGuard™ system push-button (optional)
- 69. Emergency push-button. Press it in case of emergency to stop all the machine functions.
To deactivate the emergency push-button, turn it in the direction shown by the arrow.
- 70. USB socket (optional)
- 71. Multifunction display
Items displayed:
 - A) Working hours
 - B) Battery type
 - C) Maximum running speed setting
 - D) Work screen
 - E) Main broom activation
 - F) Side brooms activation
 - G) Vacuum activation
 - H) Reverse gear activation
 - I) Side brooms speed setting
 - J) Auto-shut off timer
 - K) Hopper opening warning
 - L) DustGuard™ system
 - M) Work light turned on
 - N) Main broom worn out
 - O) Service call
 - P) Fuel reserve warning
 - Q) Engine overheat warning
 - R) Engine oil pressure warning
 - S) Alternator warning

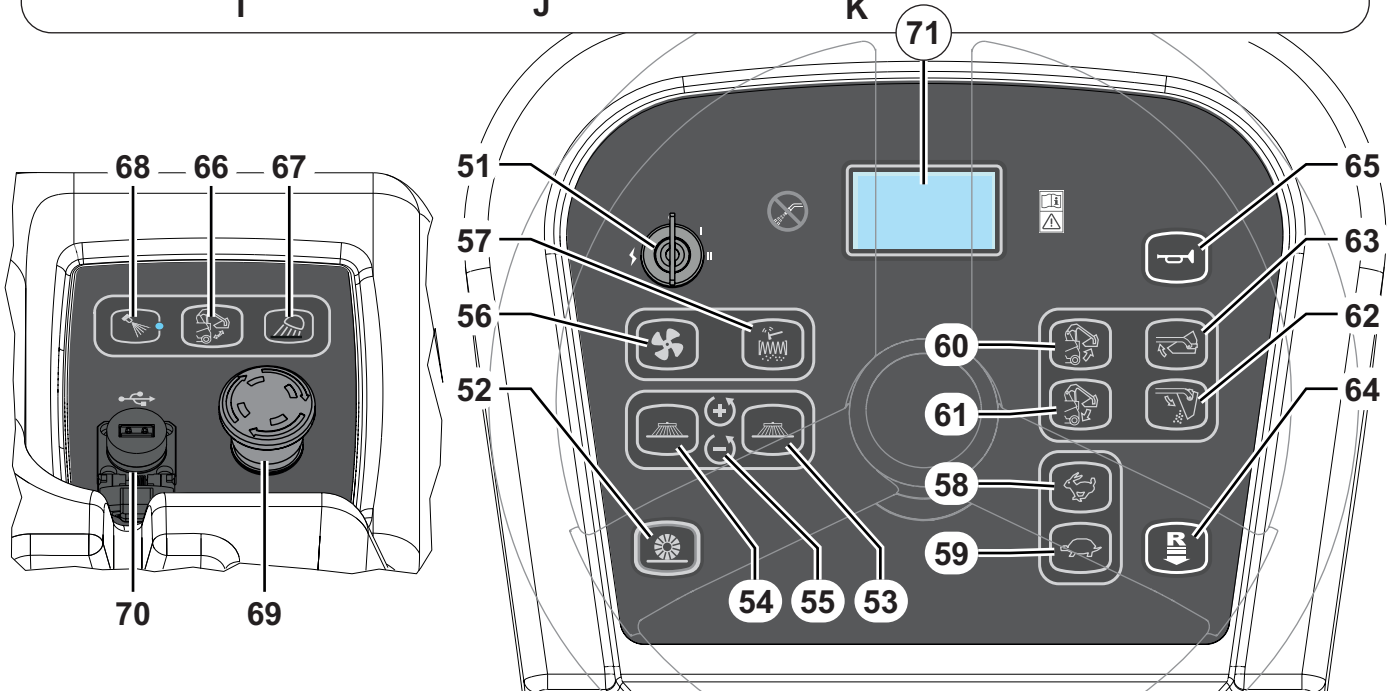
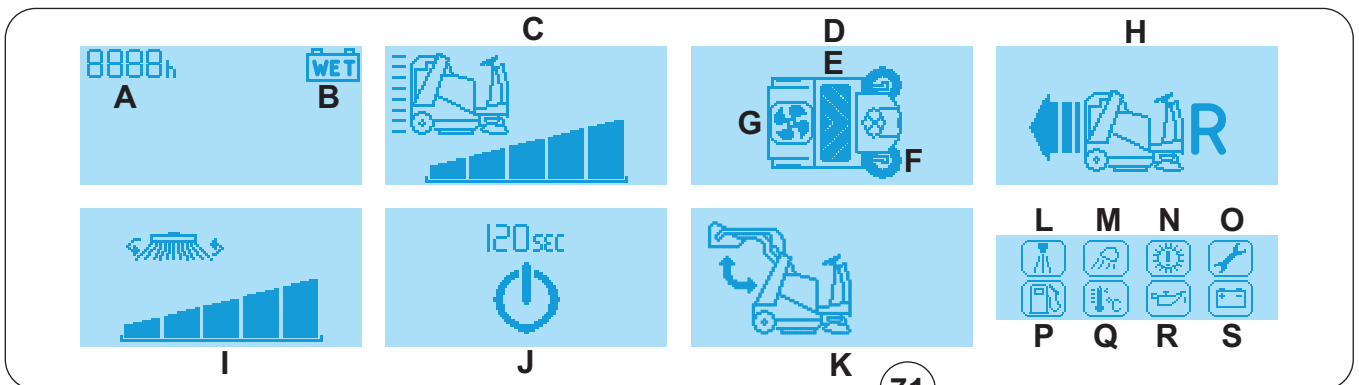

P100921

ACCESSORIES/OPTIONS

In addition to the standard components, the machine can be equipped with the following accessories/options, according to the machine specific use:

- Left side broom
- Non-marking wheels
- Main and side brooms with harder or softer bristles
- FOPS protective roof
- Paper dust filter
- Roof cover
- Non-marking skirts
- Side broom guards
- Safety belts
- DustGuard™ system
- Right and left armrests
- USB™ socket
- Hybrid motor

For further information concerning the optional accessories, contact an authorized Retailer.

TECHNICAL DATA

Model	SW5500 LPG	
Cleaning width	with one side broom	46.2 in (1,175 mm)
	with two side brooms	59 in (1,500 mm)
Main broom size (length x diameter)	33.5 x 14.2 in (850 x 360 mm)	
Side broom diameter	19.7 in (500 mm)	
Hopper	capacity	39.6 US gal (150 liters)
	maximum liftable weight	529 lb (240 kg)
	maximum lifting height	70 in (1,650 mm)
Filter	cleaning system	Electrical filter shaker
	area	10850 ft ² (7 m ²)
	filtering capacity	4 µm
Power	6.3 kW (8.4 hp) @ 3,600 rpm	
Engine model	Honda iGX 270	
Fuel type	LPG	
Fuel tank capacity	15 Kg	
Type of	engine oil	SAE 10W30
	hopper hydraulic lifting system	Arnica 46
Main broom	motor power	1.7 hp (1,250 W)
	speed	4,800 rpm
Side broom	motor power	0.16 hp (120 W)
	speed (variable)	40/155 rpm
Vacuum	motor power	0.35 hp (260 W)
Drive	type	Electrical on the front wheel
	gearmotor power	1.6 hp (1,200 W)
	forward speed	6.2 mi/h (10 km/h)
	reverse speed	2.8 mi/h (4.5 km/h)
Maximum gradient when working	20 %	
Hopper hydraulic control unit	1.1 hp (800 W)	
Filter shaker motor	2 x 0.016 hp (2 x 12 W)	
Total absorbed power	3.5 hp (2.6 kW)	
Dimensions (length x width x height)	machine body	73.8 x 47.2 x 61.6 in (1,875 x 1,200 x 1,564 mm)
	machine with side brooms	73.8 x 51.2 x 61.6 in (1,875 x 1,300 x 1,564 mm)
	machine with FOPS protective roof (optional)	73.8x47.2x78.5/81.7 in (1,875x1,200x1,995/2,075 mm)
LPG tank maximum size (length x diameter)	34.9 x 12 in (886 x 306 mm)	

TECHNICAL DATA (Continues)

Model		SW5500 LPG
Weight	kerb weight	1684 lb (764 Kg)
	total kerb weight (*)	1920 lb (871 Kg)
	front axle kerb weight (*)	804 lb (365 Kg)
	rear axle kerb weight (*)	1115 lb (506 Kg)
	gross vehicle weight (GVW)	2846 lb (1,291 Kg)
Wheel specific pressure on the floor (front - rear wheels, in running conditions)		(0.7 - 0.5 N/mm ²)
Sound pressure level at workstation (ISO 11201, ISO 4871, EN 60335-2-72) (LpA)		79 dB(A) ± 3 dB(A)
Machine sound pressure level (ISO 3744, ISO 4871, EN 60335-2-72) (LwA)		98 dB(A)
IP protection class		X3
Dust guard system water tank (optional) capacity		8.4 US gal (32 liters)
U-turn space (right - left)		91 - 93.5 in (2,310 - 2,375 mm)
Vibration level at the operator's arms (ISO 5349-1) (**)		<98.4 in/s ² (<2.5 m/s ²)
Vibration level at the operator's body (ISO 2631-1) (**)		31.5 in/s ² (0.8 m/s ²)

(*) With operator on board, fuel tank and hopper empty.

(**) Under normal working conditions, on a level asphalt surface.

Machine Material Composition and Recyclability

Type	Recyclable percentage	SW5500 LPG weight percentage
Aluminum	100 %	0.1 %
Electric motors - various	29 %	20.4 %
Ferrous materials	100 %	61.1 %
Wiring harnesses	80 %	0.0 %
Liquids	100 %	0.6 %
Plastic - non-recyclable material	0 %	0.0 %
Plastic - recyclable material	100 %	0.8 %
Polyethylene	92 %	8.1 %
Rubber	20 %	8.7 %
Cardboard - paper - wood	100 %	0.1 %

Hydraulic oil technical data

Viscosity at 104 °F (40 °C)	in ² /s (mm ² /s)	0.07 (45)	0.05 (32)
Viscosity at 212 °F (100 °C)	in ² /s mm ² /s	(7.97)	(6.40)
Viscosity index	/	150	157
Flash point COC	°F (°C)	419 (215)	396 (202)
Pour point	°F (°C)	-33 (-36)	-33 (-36)
Density at 15 °C (59 °F)	lb/US gal (kg/l)	(0.87)	(0.865)

**CAUTION!**

If the machine is to be used at ambient temperatures below 50 °F (+10 °C), the oil should be changed with equivalent oil having a viscosity of 32 cSt. For temperatures below 32 °F (0 °C), use an oil with lower viscosity.

WIRING DIAGRAM**Key**

A1	Main broom actuator
A2	Right side broom actuator
A3	Left side broom actuator (optional)
ALT	Alternator
BAT1	12 V batteries
BAT2	12 V batteries
BZ	Reverse gear buzzer
BE	Flashing light
CCOIL	Charging coil
CH	Hybrid battery charger (optional)
D1..D3	Diode
EB1	Function electronic board
EB2	Drive system electronic board
EB3	Display board
EB4	Dashboard electronic board
EB5	Seat dashboard electronic board
EB6	Honda engine ECM
EB7	Honda engine ignition coil
ECN	Encoder
ES1	Function electronic board contactor
ES2	Drive system electronic board contactor
ES3	Engine on/off relay
ES4	Engine RPM relay
ES5	Engine start relay
ES6	Fan relay
ES8	Drive system enabling relay
ES9	Horn relay
ES10	Charging system electromagnetic switch
ES11	Hybrid charging system relay
EV1	Hopper raising solenoid valve
EV2	Hopper lowering solenoid valve
EV3	Hopper solenoid valve
EV4	Fuel solenoid valve
F0	Battery fuse
F1	Function electronic board fuse
F2	Ignition key fuse
F3	Drive system fuse
F4	Alternator fuse
F5	Engine fuse
F6	Engine start fuse
F7	Fan fuse
F8	Horn fuse
HN	Horn
KEY	Ignition key
L1	Working light (optional)
M0	Driving wheel
M1	Vacuum system motor
M2	Filter shaker motor
M3	Hopper pump motor
M4	Main broom motor
M5	Right side broom motor
M6	Left side broom motor (optional)
M7	Engine compartment fan
MST	Starter
P1	Dust guard system pump motor (optional)
R1	Accelerator pedal
R2,...4	Resistance
S1	Opened hopper sensor
S2	High hopper sensor
S3	Rotated hopper sensor
S4	Main broom wear sensor

S5	Driving wheel temperature sensor
S6	Fuel reserve sensor
S7	Oil alert sensor
S8	Diode jumper temperature sensor
SPK	Engine spark plug
SW0	Emergency push-button
SW1	Driver's seat safety microswitch
TU	Trackunit (optional)
USB	USB port (optional)

Color codes

BK	Black
BU	Blue
BN	Brown
GN	Green
GY	Grey
OG	Orange
PK	Pink
RD	Red
VT	Violet
WH	White
YE	Yellow

WIRING DIAGRAM (Continues)

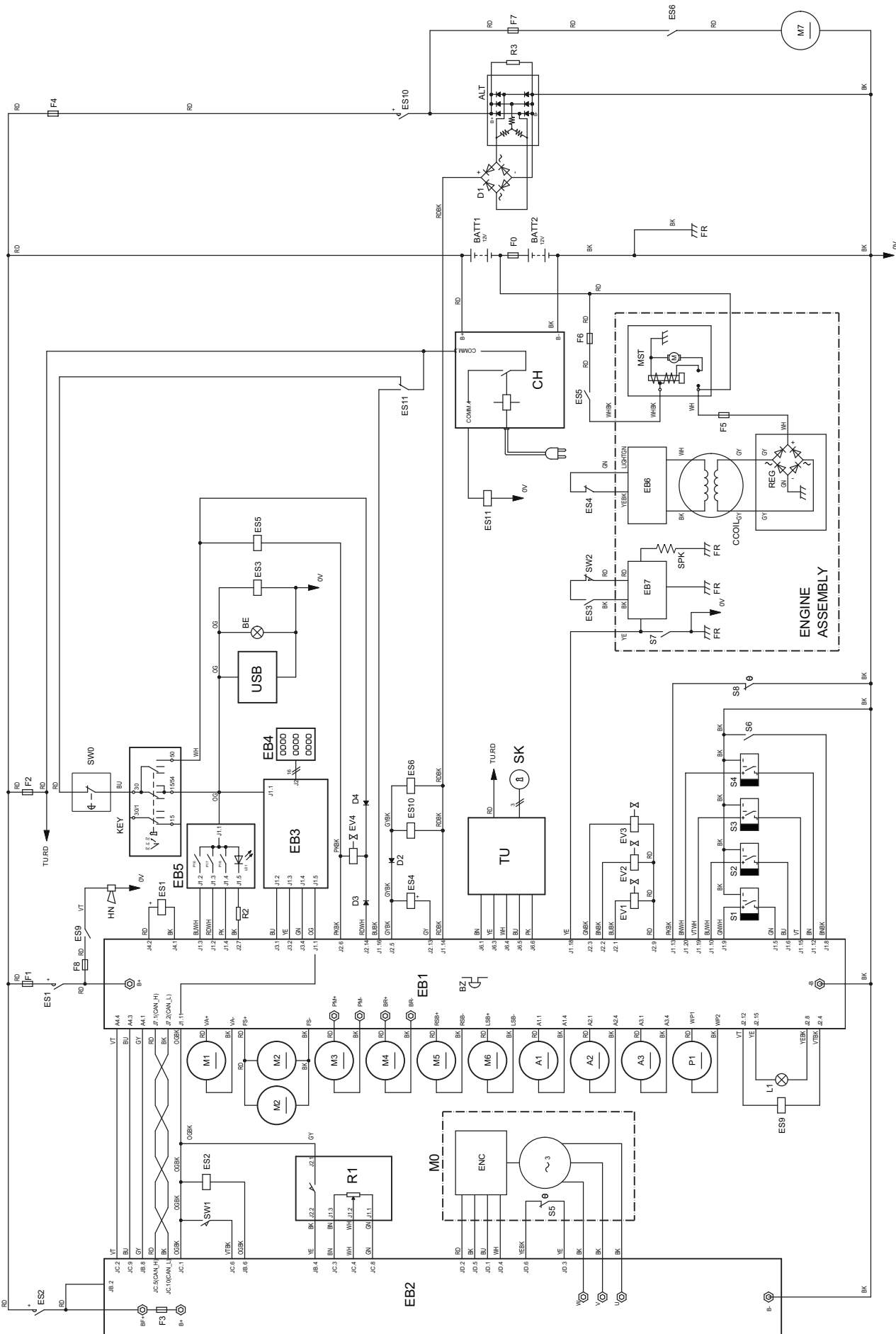

P100923

USE**WARNING!**

On some points of the machine there are some adhesive plates indicating:

- **DANGER**
- **WARNING**
- **CAUTION**
- **CONSULTATION**

While reading this Manual, the operator must pay particular attention to the symbols shown on the plates (see the Visible Symbols On The Machine paragraph).

Do not cover these plates for any reason and immediately replace them if they are damaged.

If the machine has not been used after being transported, check that all the blocks have been removed.

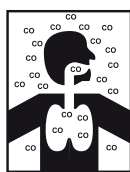
FUEL**DANGER!**

- **Carbon monoxide (CO) can cause brain damage or death.**
- **The internal combustion engine of this machine can emit carbon monoxide.**
- **Do not inhale exhaust gas fumes.**
- **Only use indoors when adequate ventilation is provided, and with the help of an assistant.**

**DANGER!**

Before replacing the LPG tank, close the safety valve and disconnect the hose.

1. Install an LPG tank (34) having characteristics which comply with the laws in force in the country where it is used.
2. Fasten the tank with a fastening band (35).
3. Connect the hose and open the cut-off valve on the LPG tank. Always wear gloves when connecting and disconnecting the hose. When the machine is not operating, close the LPG tank cut-off valve.

**NOTE**

Place the LPG tank in a proper horizontal position. Connect the hose to the tank and check that there are no gas leaks.

**DANGER!**

Do not use the machine in case of gas leaks. Disconnect the hose and replace the LPG tank. If the gas leak persists, disconnect the hose and contact the Advance Service Center.

BEFORE MACHINE START-UP

Checklist

1. Have a full knowledge of the machine operating controls and their functions.
2. Insert the key (51) and start the machine (see the procedure in the following paragraph).
3. In the first 2 seconds after turning on, the multifunction display (71) shows the machine working hours (71-A), the type of batteries set (71-B) and the current maximum machine speed setting (71-C).
4. Check the fuel reserve icon (71-P); if it is lit, range will be limited. Replace the LPG tank (see previous paragraph).
5. Check the horn with switch (65), the reverse gear buzzer with switch (64) and the working light switch (67, optional) for proper operation.
6. Check the parking brake (7 and 6). The brake must hold its (locked parked) setting firmly without easily being released (report all defects immediately to Advance Service Center).
7. Check the service brake pedal (6) for proper operation.



WARNING!

If the pedal is "spongy" or fades under pressure without an efficient braking force, do not drive the machine (report all defects immediately to Advance Service Center).

8. Make sure that there are no open doors/hoods and that the machine is in normal operating conditions.

Cleaning planning

1. Arrange long runs with a minimum of stopping or starting.
2. Allow a small amount of broom path overlap to ensure complete coverage.
3. Avoid making sharp turns, bumping or scraping the side of the machine.

Filling the DustGuard™ system water tank (optional)

1. Remove the plug (25) to reach the filler neck.
2. Fill the tank (24) with clean water. Do not fill the tank completely, leave a few centimeters from the edge.

STARTING AND STOPPING THE MACHINE

Starting the machine

1. Sit on the driver's seat (3) and adjust it with the lever (4) to allow easy reach of all controls.



NOTE

The driver's seat (3) is equipped with a safety sensor, which allows the machine to be driven only when the operator is on the driver's seat.

2. Turn the ignition key (51) clockwise to the "I" position.
3. Wait for the multifunction display to show the work screen (71-D).
4. Turn the ignition key (51) to the start position "II", then release it when the engine starts.
5. After starting, let the engine idle for a few seconds.



CAUTION!

When starting do not press the accelerator pedal (5).

6. Disengage the parking brake.
7. Drive the machine to the working area, maneuvering it by turning the steering wheel with your hands (1) and pressing the accelerator pedal (5).
The speed can be adjusted by applying more or less pressure to the accelerator pedal (5).
The maximum running speed can be set with push-buttons (58) and (59).
8. The forward/reverse direction is selected with the relevant push-button (64) on the dashboard. Activation of reverse gear is indicated by the buzzer and on the display (71-H).



WARNING!

When steering, avoid abrupt direction changes, pay careful attention and drive the machine at slow speed, especially when the hopper is full or when operating on inclines.

Drive the machine slowly on inclines. Use the brake pedal (6) to control machine speed while descending inclines.

Do not turn the machine on an incline; drive straight up or down.



NOTE

The machine has an anti-skid safety system, which where necessary reduces speed when steering and when the machine is driving on a camber, regardless of the pressure applied to the pedal.

This reduction in speed is therefore not a malfunction but a characteristic which increases the stability and safety of the machine in all conditions.

Hybrid motor (optional)

1. Perform steps 1 to 3 of the machine start-up paragraph.
2. Ignition of the engine is not necessary while the batteries retain a sufficient level of charge.
3. Check the battery charge while working. While at least one segment of the battery icon (A, Fig. 1) is lit and not flashing on the multifunction display (71), the machine can be used with the engine off. When the battery icon (A) has only one flashing segment remaining (B, Fig. 1), it is advisable to start the engine, or else to recharge the batteries using the on-board battery charger (see procedure in the Maintenance chapter).
4. To start using the machine again with the engine off, press the push-button (36) and hold it down until the engine turns off.
5. When the multifunction display shows screen (B), a complete battery charging cycle must be performed using the on-board battery charger. Complete the job in progress before taking the machine to the area for charging its batteries.
6. Perform a complete charging cycle before using the machine again (see procedure in the Maintenance chapter).

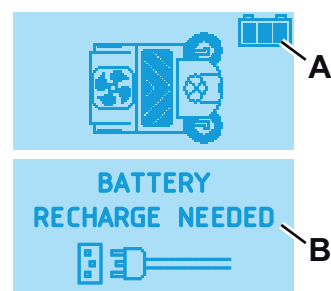

P100924

Figure 1

Stopping the machine

1. To stop the machine, release the accelerator pedal (5).
2. To stop the machine quickly, also press the service brake pedal (6).



WARNING!

The machine regulates its speed in proportion to the pressure on the accelerator pedal, accelerating and decelerating as a result. In some particular working and environmental conditions (e.g. steep descents), the automatic deceleration may deactivate itself to protect the system. For this reason, always use the service brake (6) to be sure of the machine's stopping distance.

3. In case of emergency, press the emergency push-button (69) to immediately stop the machine. To deactivate the emergency push-button (69), turn it clockwise.



WARNING!

The emergency push-button (69) also deactivates the machine's automatic deceleration system; if operated while moving, use the service brake (6) to stop the machine.

4. Turn the ignition key (51) to "0" and remove it.

PARKING BRAKE

1. Engage the parking brake by pressing the pedal (6) and engaging the lever (7).
2. Disengage the parking brake by pressing and releasing the pedal (6).



WARNING!

Before performing any maintenance, repair, cleaning or replacement procedure engage the parking brake. Engage the parking brake when parking the machine on a slope.



WARNING!

Before leaving the machine unattended, be sure that the parking brake can stop the machine with a large safety margin.



WARNING!

When using the machine on slopes, respect the maximum gradient values marked on the machine itself (see technical characteristics table).

MACHINE OPERATION

1. Drive the machine to the work area as shown in the previous paragraph.
2. Start cleaning by lowering the main broom and activating the vacuum system with the One-Touch push-button (52).
3. (Optional) activate the DustGuard™ system with the corresponding push-button (68).
4. Lower the side brooms with the push-buttons (53) and (54, optional). If necessary, adjust the speed of the side brooms with the + and - push-buttons (55, icon on display 71-I).



NOTE

The brooms (18, 15 and 16) can be lowered and lifted even when the machine is moving. When the brooms are lowered, the brooms, the vacuum system and the dust guard system (optional) automatically activate only when the machine is moving.



NOTE

The side broom icons (71-F) keep the operator informed of the working configuration of the side brooms. When the icon is present, the corresponding side broom is activated and deactivated together with the main broom via the One-Touch push-button (52).

5. Start sweeping by driving the machine with the hands on the steering wheel (1) and by pressing the accelerator pedal (5). If necessary, set the maximum speed with the push-buttons (58) and (59).
6. Drive the machine straight forward at a quick walking speed. Drive the machine slower when sweeping large amounts of dust or debris or when safe operation dictates slower speeds. Overlap passes 10 cm.
7. To collect light and bulky waste materials, lift the front skirt by pressing the pedal (8); take into consideration that the machine vacuum capability is reduced when the front skirt is lifted.



WARNING!

When operating on wet floors, it is essential to turn off the vacuum system by pressing the push-button (56) to prevent the dust filter from being damaged.

8. For machine proper operation, the dust filter must be as clean as possible. To clean it while sweeping, operate the filter shaker by pressing the push-button (57).
While working, repeat the procedure every 10 minutes on average (depending on the dustiness of the area to be cleaned).



NOTE

This procedure can also be performed when the machine is moving.



CAUTION!

When the dust filter is clogged and/or the hopper is full, the machine cannot collect dust and debris any more.

9. The hopper (12) should be dumped after each working period and whenever it is full (see the procedure in the next paragraph).



CAUTION!

The engine is equipped with a warning system to prevent damages to the engine itself in case the oil quantity in the carter is insufficient. Before the oil level goes below the safety limit, the warning system automatically stops the engine and displays the icon (71-R) on the multifunction display.



CAUTION!

In the event of an overload of one of the broom motors, due to foreign bodies blocking it or excessive pressure of the broom on the ground (see procedure in the Main/Side Broom Height Check and Adjustment paragraph of the Maintenance chapter), a safety system stops the motor.

HOPPER DUMPING



WARNING!
The hopper (12) must be emptied on level grounds only.
Do not lift the hopper when the machine is on a slope.



WARNING!
When lifting and dumping the hopper (12), make sure that there are no people around the machine, especially near the hopper.



NOTE
When the hopper (12) is lifted, the vacuum system turns off automatically and the machine maximum speed is reduced for safety reasons.

To empty the hopper, move the machine close to the dustbin and proceed as follows.

1. Lift the side and main brooms.
2. Press the enable push-button (66) while pressing the hopper lifting push-button (61) to lift the hopper (A, Fig. 2) up to the desired position.
3. Drive the machine to the disposal area and engage the parking brake.
4. Rotate the hopper (B) with the enable push-button (66) and push-button (62) to dump the accumulated waste (C).



CAUTION!
The hopper (A) can be dumped only when lifted at a minimum height of 35 cm approximately.
The maximum dumping height is approx. 150 cm.

5. Rotate the hopper back with the enable push-button (66) and push-button (63).
6. Lower the hopper by pressing both the enable push-button (66) and push-button (61) at the same time.



CAUTION!
Check that the hopper opening icon (71-K) on the display disappears and the buzzer stops to be sure that the hopper (12) has fully returned to its working position.

7. The machine is ready to start sweeping again.

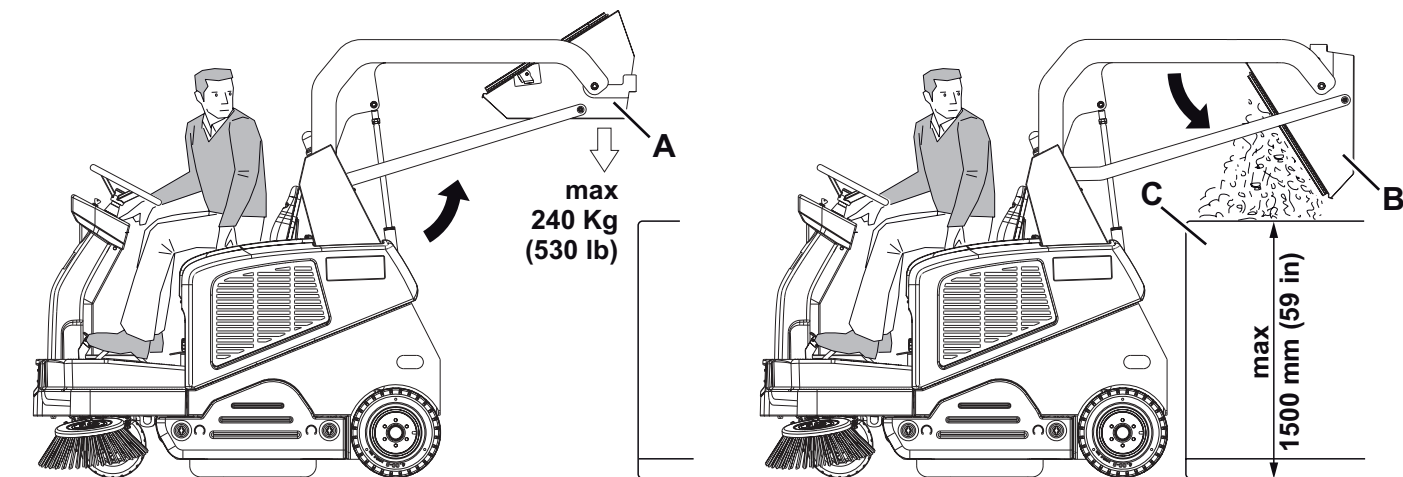

P100895

Figure 2

AFTER USING THE MACHINE

After working, before leaving the machine, perform the following procedures.

- Activate the filter shaker briefly by pressing the push-button (57).
- Empty the hopper (12) (see the procedure in the previous paragraph).
- Raise the brooms with the One-Touch push-button (52).
- Close the safety valve on the LPG tank (32), then let the engine run until all the fuel is expelled from the hoses (then the engine is stopped).
- Turn off the machine by turning the ignition key (51) to “0”, then remove it.
- Engage the parking brake.



NOTE

If the machine is left parked and inoperative, with the ignition key (51) in the “I” position, for more than 5 minutes, the electrical system switches to a low power consumption mode (stand-by). To start work again, it is necessary to shut off and restart the machine with the ignition key (51).

MACHINE LONG INACTIVITY

If the machine is not going to be used for more than 30 days, proceed as follows:

- Perform the procedures shown in After Machine Use paragraph.
- Check that the machine storage area is dry and clean.
- Close the LPG tank safety valve.
- Disconnect the negative connector (-) of the batteries (47).
- Handle the engine (43) as shown in the relevant Manual.
- (For machines equipped with dust guard system). Empty the tank (23) and clean the water filter (see the procedure in Maintenance chapter).

MAINTENANCE

The lifespan of the machine and its maximum operating safety are ensured by correct and regular maintenance.

The following table provides the scheduled maintenance. The intervals shown may vary according to particular working conditions, which are to be defined by the person in charge of the maintenance.

All scheduled or extraordinary maintenance procedures must be performed by qualified personnel, or by an authorized Service Center.



CAUTION!



Each time the Service icon is shown on the display (71), contact an authorized Advance Service Center for scheduled maintenance.

This Manual describes only the easiest and most common maintenance procedures.

For other maintenance procedures shown in the Scheduled Maintenance Table, refer to the Service Manual that can be consulted at any Service Center.



WARNING!

To perform maintenance procedures, the machine must be off, the ignition key removed, and, if necessary, the batteries must be disconnected.

Read carefully the instructions in the Safety chapter before performing any maintenance procedure.

SCHEDULED MAINTENANCE TABLE

Procedure	Upon delivery	Every 10 hours	Every 50 hours	Every 100 hours	Every 200 hours	Every year
Engine oil level check	(1)					
Battery fluid level check		(2)				
Side and main broom height check						
Engine air filter check		(1)				
Hopper dust filter check and cleaning (“A” method)			(3)			

SCHEDULED MAINTENANCE TABLE (Continues)

Procedure	Upon delivery	Every 10 hours	Every 50 hours	Every 100 hours	Every 200 hours	Every year
Hopper lifting system hydraulic oil level check			(2)			
Skirt height and operation check						
Dust guard system water filter check and cleaning (optional)						
Brake cable check/adjustment			(*) (4)			
Engine air filter cleaning			(3)	(3)		
Hopper dust filter check and cleaning ("B" method)				(3)		
Filter shaker operation check				(*)		
Main broom drive belt visual inspection				(*)		
Engine oil change				(5) (6)		
Spark plug check/cleaning						
Steering chain cleaning				(*)		
Steering chain check/adjustment				(*)		
Safety device operation check				(2)		
Engine baffle plate cleaning				(7)		
Brake drums check/adjustment/replacement				(*) (4)		
Hopper dust filter check and cleaning ("C" method)					(3)	
Main broom drive belt check and/or replacement					(*)	
Hopper gasket integrity check					(*)	
Lifted hopper sensor operation check/adjustment					(*)	
Motor carbon brush check and/or replacement						(*)
Paper engine air filter replacement						
Spark plug replacement						
Engine idle speed check/adjustment						(*)
Valve clearance check/adjustment						(7)
Hydraulic system oil change						(*) (8)
Supply hose replacement						(*)
Engine combustion chamber cleaning						Every 500 hours (7)

(*) For the relevant procedure, refer to the Service Manual.

- (1) Daily or after using the machine.
- (2) Or before start-up.
- (3) Or more often in dusty areas.
- (4) Or more frequently if the machine is used on slopes.
- (5) Or every 6 months.
- (6) And after the first 20 running-in hours.
- (7) Maintenance procedures to be performed by an authorized Honda/Yanmar dealer.
- (8) Change the hydraulic system oil after 500 hours or every year.

MULTIFUNCTION DISPLAY SERVICE SCREENS

Main screen (E, Fig. 3)

1. Turn the ignition key (51) to the starting position "I" while holding down push-buttons (52) and (53) to access the main screen (E, Fig. 3).
2. Press push-button (A) to change the machine settings (see the Machine Settings Screen paragraph).
3. Press push-button (B) to check any alarms stored by the machine (see the Alarms Memory Screen paragraph).
4. Press push-button (C) to check the machine working hours (see the Hour Counter Screen paragraph).
5. Press push-button (D) to exit super user mode and return to operator mode.

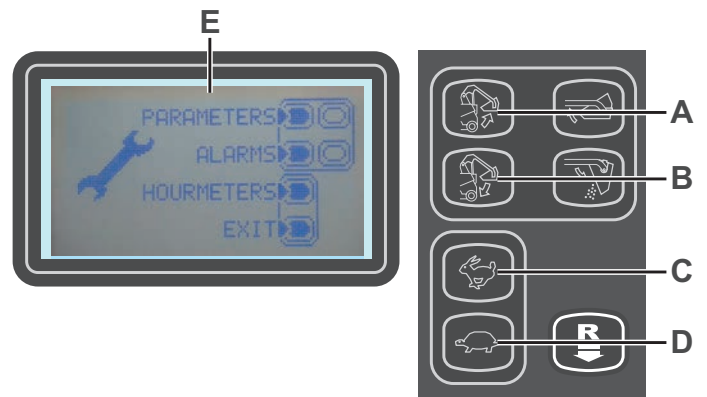

Figure 3

P100897

Machine Settings Screen (F, Fig. 4)

This function allows you to customize the value of the parameters described in the following table of modifiable parameters.

1. To increase the value of the current parameter, press push-button (C).
To decrease the value of the current parameter, press push-button (D).
2. To move to the next parameter, press push-button (A).
3. To return to the main screen, hold down push-button (B).

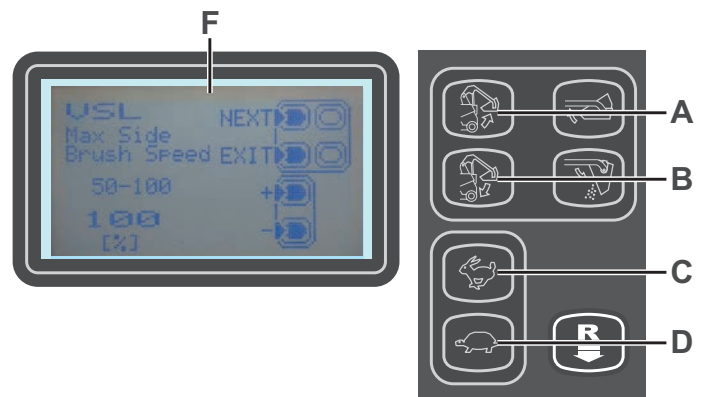

Figure 4

P100898

TABLE OF MODIFIABLE PARAMETERS		Values		
Code	Description	Minimum	Factory Setting	Maximum
VSL	Side broom speed	50%	100%	100%
SCF	Filter shaker activation time	5 sec	20 sec	60 sec.
FVMIN	Minimum forward speed	0%	25%	100%
FVMAX	Maximum forward speed	10%	85%	100%
RVMAX	Maximum reverse speed	10%	30%	50%
BAT (*)	Installed battery type (see table)	0	0	1
TOFF	Automatic shut-off time	0 sec	300 sec	600 sec
BRGH	Display contrast	5	25	50
RESET	Resets all parameters to the factory default values	0	0	1

Installed Battery type		Value
WET	Battery with liquid acid electrolyte	0
GEL / AGM	Generic GEL or AGM batteries	1

(*) Significant only when the Hybrid Kit is installed

Alarm Memory Screen (G, Fig. 5)

This function allows you to check any alarms stored by the machine.

Use this function only with the support of the Advance Service Centre to solve problems with machine operation.

To return to the main screen (E, Fig. 3), press push-button (A) repeatedly.

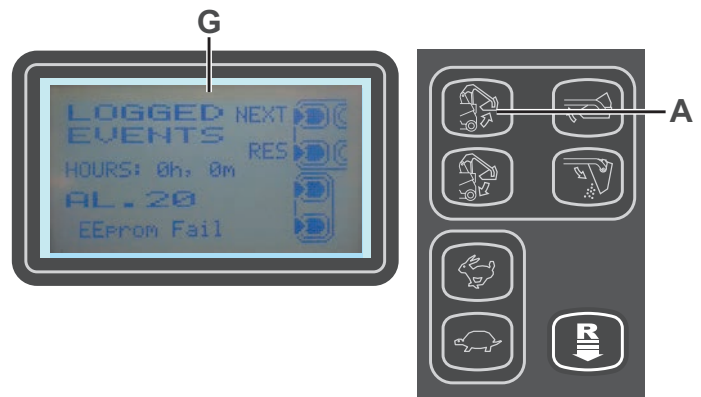

P100899

Figure 5

Hour counter screen (H, Fig. 6)

This function allows you to check the accumulated hours of operation for each of the machine's subsystems:

- TOTAL hour counter (machine on time)
- SIDE BROOMS hour counter (side brooms usage time)
- MAIN BROOM hour counter (main broom usage time)
- DRIVE hour counter (drive system usage time)
- VACUUM hour counter (vacuum system usage time)

To return to the main screen (E, Fig. 3), press push-button (A).

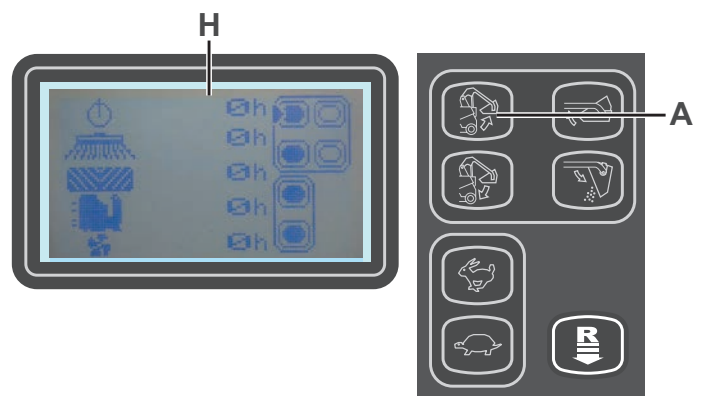

P100900

Figure 6

MAIN BROOM HEIGHT CHECK AND ADJUSTMENT



NOTE

Brooms with harder or softer bristles are available. This procedure is applicable to all types of brooms.

- Check the main broom height as shown below:
 - Drive the machine on a level ground.
 - Engage the parking brake.
 - Lower the main broom with the One-Touch push-button (52).
 - Start broom rotation by pressing the One-Touch push-button (52) again and holding it down for 3 seconds.
 - After 30 seconds of broom operation (visible on the display, as per Figure 7), raise it by pressing the One-Touch push-button (52).
 - Check that the main broom print (A, Fig. 8), along its length, is 2 to 4 cm wide.

If the print (A) is not within specifications, adjust the main broom height according to the following procedure.

- Turn the knob (B, Fig. 9) as shown below:
 - To increase the print width, turn the knob counter-clockwise.
 - To decrease the print width, lift the main broom with the One-Touch push-button (52) and then turn the knob clockwise.

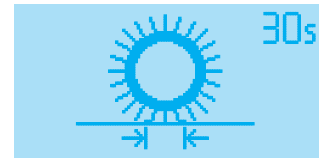
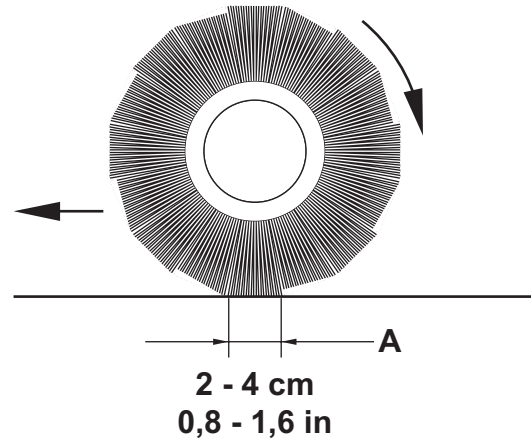

Figure 7



P100901



NOTE

The knob can be used both to adjust the print and to adjust the broom according to the bristle wear.

- Perform step 1 again to check that the main broom is at the correct distance from the ground.
- When the icon (71-N) appears on the display, change the broom as described in the next paragraph.



NOTE

If it is not possible to adjust the print (A, Fig. 8) properly, because the pressure on the floor at the ends of the broom is different, refer to the Service Manual.

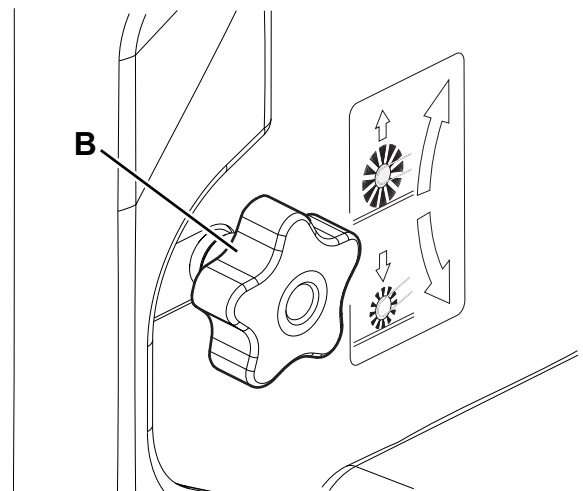

Figure 8

Figure 9

P100902

P100903

MAIN BROOM REPLACEMENT



WARNING!

It is advisable to wear protective gloves when replacing the main broom because there can be sharp debris between the bristles.

1. Drive the machine on a level ground and engage the parking brake.
2. Ensure that the main broom is in the lifted position.
3. Turn the ignition key (51) to "0" and remove it.
4. Remove the left door (A, Fig. 10) by turning the fasteners (B).
5. Pull the knob (C, Fig. 11) as indicated by the arrow to disengage the closing support (D).
6. Turn and open the closing support (D) together with the left side skirt (E).
7. Remove the main broom (F, Fig. 12).
8. Check that the drive hub (G) is free from dirt or foreign materials (cords, rags, etc.) accidentally rolled up.
9. The new main broom must be installed with the bristles rows bent as shown in the figure (H).
10. Install the new main broom and ensure that the hexagonal mesh (I) fits into the relevant drive hub (G).
11. Turn and close the closing support (D, Fig. 11); when closing, slightly pull the knob (C) until it clicks.



NOTE

When closing, manually push the main broom to engage it in the conical hub of the closing support (D).

12. Refit the left door (A, Fig. 10) and close it with the fasteners (B).



CAUTION!

Check and adjust the main broom height as shown in the previous paragraph.

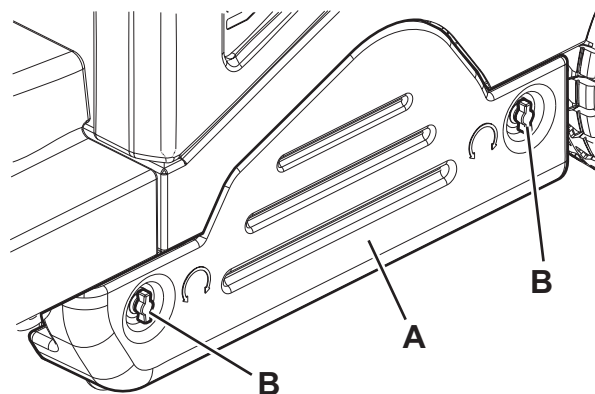

Figure 10

P100904

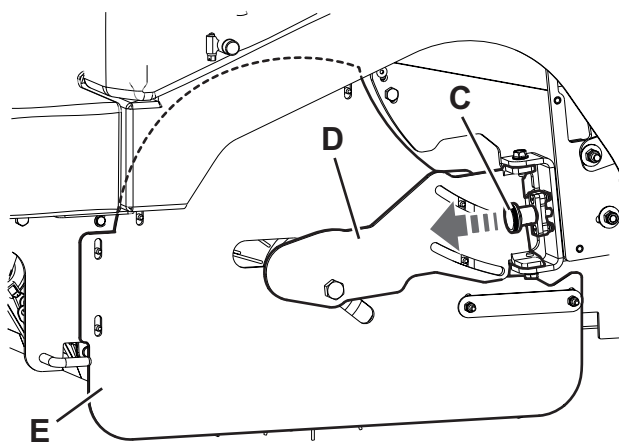

Figure 11

P100905

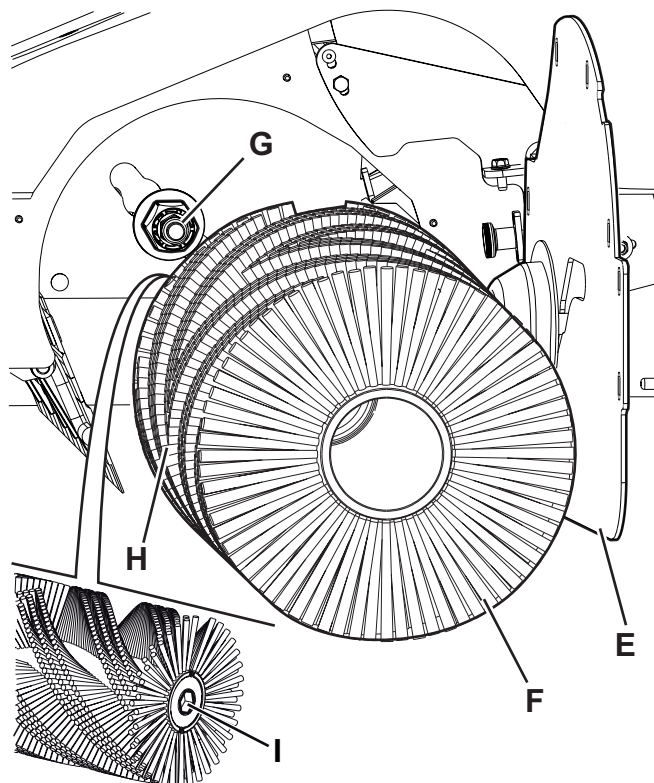

Figure 12

P100906

SIDE BROOM HEIGHT CHECK AND ADJUSTMENT



NOTE

Brooms with harder or softer bristles are available. This procedure is applicable to all types of brooms.

1. Check the side broom distance from the ground, according to the following procedure:
 - Drive the machine on a level ground.
 - Keep the machine stationary, lower the side brooms and turn them on for a few seconds.
 - Stop and lift the side brooms, then move the machine.
 - Check that the side broom prints are as shown in the figure (A and B, Fig. 13).

If the print is not within specifications, adjust the side broom height according to the following procedure.

2. Engage the parking brake.
3. Turn the ignition key (51) to "0".
4. For the right side broom, operate on the idle gear by loosening the knob (C, Fig. 14), then turn the adjustment knob (D) and note the following:
 - To increase the print, turn the knob counter-clockwise.
 - To decrease the print, turn the knob clockwise.
5. After adjusting, lock the idle gear with the knob (C).
6. For the left side broom, operate on the idle gear by loosening the knob (E) and adjust the knob (F).
7. After adjusting, lock the idle gear with the knob (E).
8. Perform step 1 again to check the print of the side broom on the ground.
9. When the broom is too worn to be adjusted, replace it as shown in the next paragraph.



NOTE

If necessary, the side broom tilting can be adjusted too (see the procedure in the Service Manual).

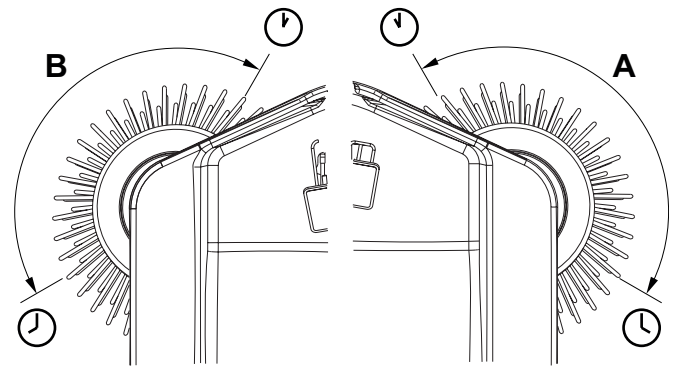

P100907

Figure 13

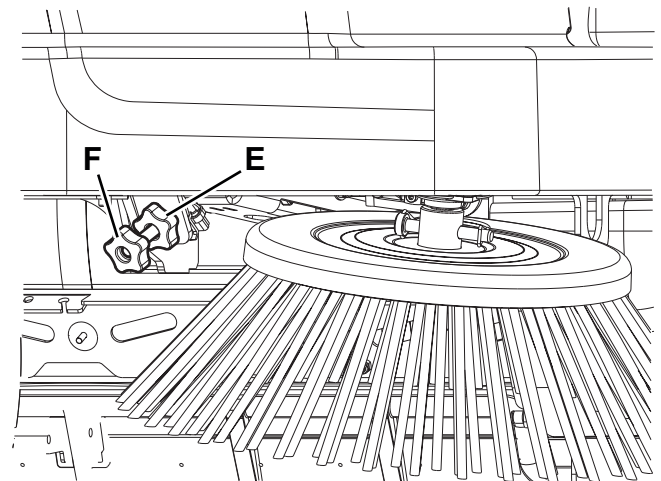
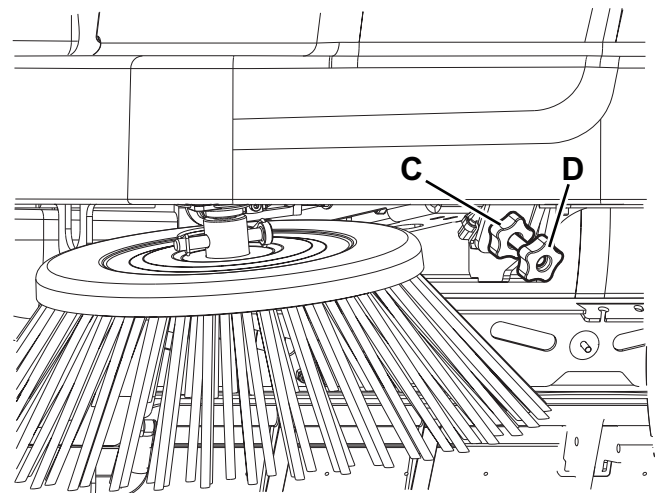

P100908

Figure 14

SIDE BROOM REPLACEMENT**WARNING!**

It is advisable to wear protective gloves when replacing the side broom because there can be sharp debris between the bristles.

1. Drive the machine on a level ground and engage the parking brake.
2. Turn the ignition key (51) to "0".
3. Remove the pin clip (A, Fig. 15), then remove the pin.
4. Remove the broom (B) and recover the protection flange (C).
5. Install on the hub (D) the new side broom with the protection flange.
6. Insert the fastening pin and engage its safety clip.
7. Check and adjust the side broom height as shown in the previous paragraph.

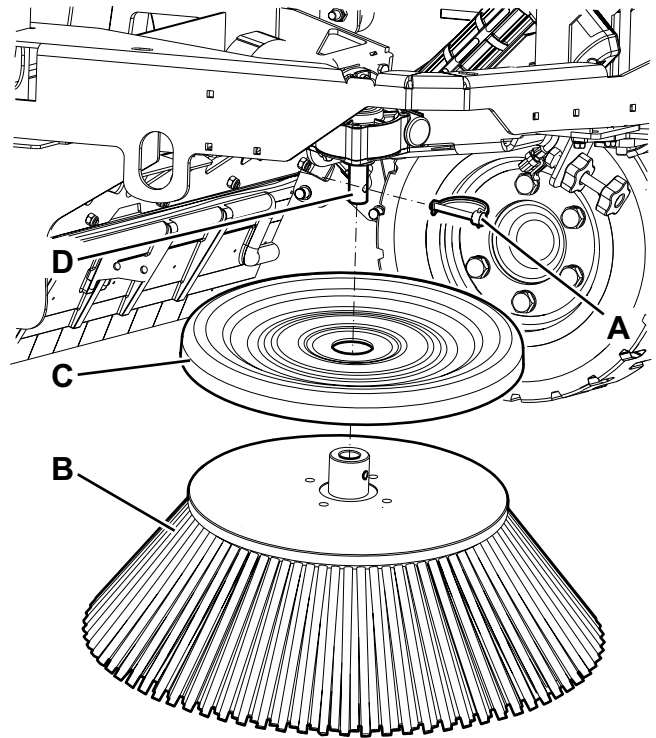

P100909

Figure 15

PANEL DUST FILTER CLEANING AND INTEGRITY CHECK

The dust filter must be regularly cleaned to maintain the efficiency of the vacuum system. Follow the recommended filter service intervals for the longest filter life.



WARNING!

- **Wear safety glasses when cleaning the filter.**
- **Do not puncture the filter.**
- **Clean the filter in a well-ventilated area.**
- **Wear appropriate dust mask to avoid breathing in dust.**

1. Drive the machine on a level ground, engage the parking brake and turn the ignition key (51) to "0".
2. Open the engine compartment hood (19) and fasten it with the support rod (44).
3. Release the fasteners (A, Fig. 16) and open the vacuum system cover (B).
4. Lift the dust filter (C, Fig. 17) and remove it from the machine.
5. Clean the filter using one of the methods below:

Method "A"

Collect dust from the filter. Gently tap the filter against a flat surface (with the dirty side down) to remove dust and dirt.



NOTE

Take care not to damage the metal lip which extends past the gasket.

Method "B"

Collect dust from the filter. Blow compressed air (maximum pressure 6 Bar) into the clean side of the filter (in the opposite direction of the airflow).

Method "C" (only for optional polyester filter)



CAUTION!

For the paper filter: do not use water or detergents to clean it, otherwise the filter could be damaged.

Collect dust from the filter. Then soak the filter in warm water for 15 minutes, then rinse it under a gentle stream of water (maximum pressure 2.5 Bar). Let the filter dry completely before installing it back into the machine.

For a better cleaning, it is allowed to wash the filter with water and non-lathering detergents.

This provides better quality cleaning but reduces the life of the filter, which will have to be replaced more frequently. The use of inadequate detergents can damage the filter.

6. Install the filter in the reverse order of removal and note the following:
 - Clean the filter housing.
 - Install the filter with the wire gauze upwards (D, Fig. 17).
 - If the filter gasket is damaged or missing, it must be replaced.
7. Press the lever (E) to disengage and close the cover (B, Fig. 16).
8. Engage the fasteners (A).

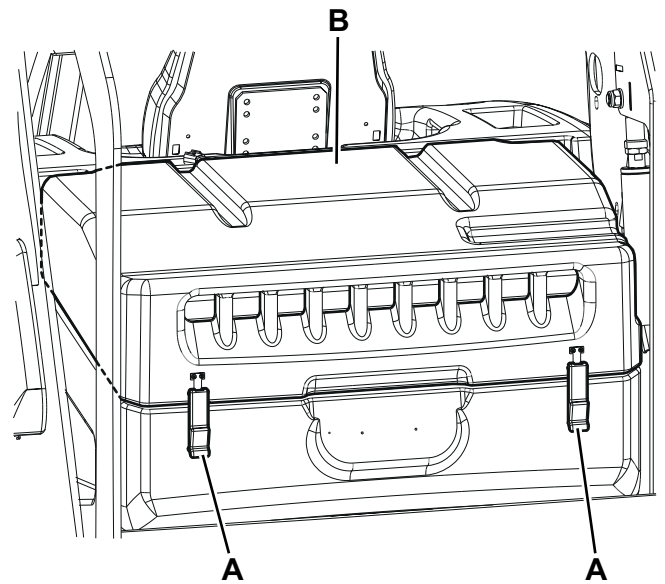

Figure 16

P100910

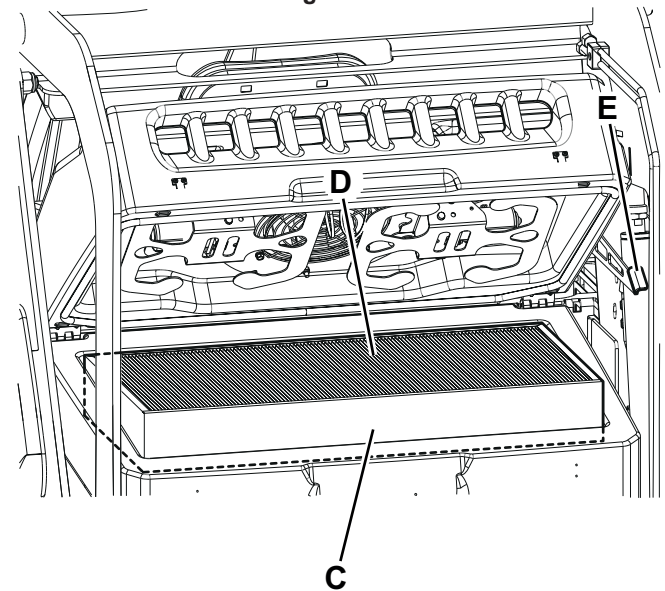

Figure 17

P100911

SKIRT HEIGHT AND OPERATION CHECK

Preliminary Operations

1. Empty the hopper (as shown in Use chapter), because the weight of the waste inside the hopper can affect the skirt height check.
2. Drive the machine on a level ground that is suitable for checking the skirt height.
3. Turn the ignition key (51) to "0" and engage the parking brake.

Side Skirt Check

4. Remove the left and right doors (14 and 13) by turning the fasteners.



NOTE
The right door fasteners (13) must be turned with a tool.

5. Check the condition of the side skirts (A, Fig. 18) and (B). Replace the skirts when they have cuts (C, Fig. 19) larger than 20 mm or cracks/tears (D) larger than 0.4 in (10 mm) (for skirt replacement, refer to the Service Manual).
6. Check that the distance from the floor of the side skirts (A, Fig. 18) and (B) is within 0 and 0.12 in (0 and 3 mm) (E, Fig. 20).

If necessary, loosen the nuts (F, Fig. 18) and adjust the skirt position. Finally, tighten the nuts (F).

Front and Rear Skirt Check

7. Remove the main broom as shown in the relevant paragraph.
8. Check the condition of the front (G, Fig. 21) and rear skirts (H) and (I). Replace the skirts when they have cuts (C, Fig. 19) larger than 20 mm or cracks/tears (D) larger than 0.4 in (10 mm).
9. Check that the front (G, Fig. 21) and rear skirt (I) slightly rub ground without being detached from it (J, Fig. 20).
10. For the skirt replacement, see the Service Manual.

Reassembly

11. Assemble the components in the reverse order of disassembly.

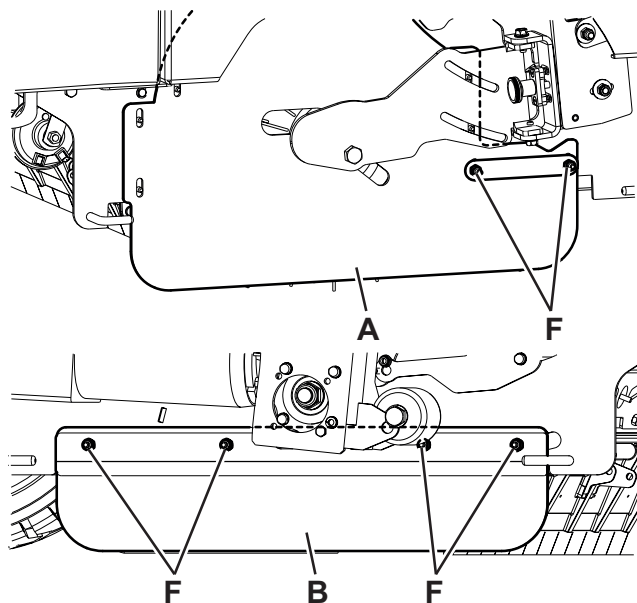

Figure 18

P100912

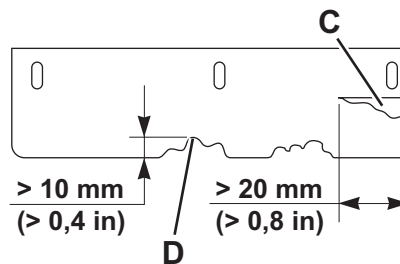

Figure 19

P100913

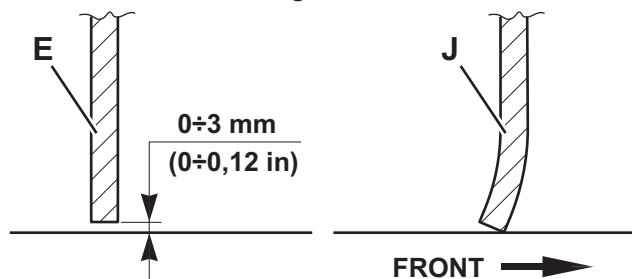

Figure 20

P100914

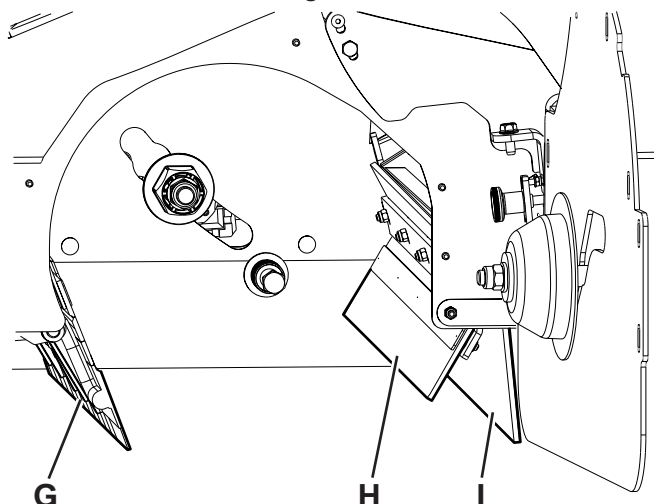

Figure 21

P100915

DUSTGUARD™ SYSTEM WATER FILTER CLEANING (OPTIONAL)



NOTE

To prevent water from flowing out when cleaning the filter, turn on the dust guard system and empty the system tank (23).

1. Drive the machine on a level ground.
2. Turn the ignition key (51) to "0" and engage the parking brake.
3. Lift and remove the left side panel (32) to reach the water filter assembly (A, Fig. 22) of the dust control system.
4. Unscrew and remove the transparent cover (B) with the gasket (C), then remove the filter strainer (D).
5. Clean and install them on the support (E).



NOTE

Install the gasket (C) and the filter strainer (D) in the housings of the cover and of the filter assembly holder.

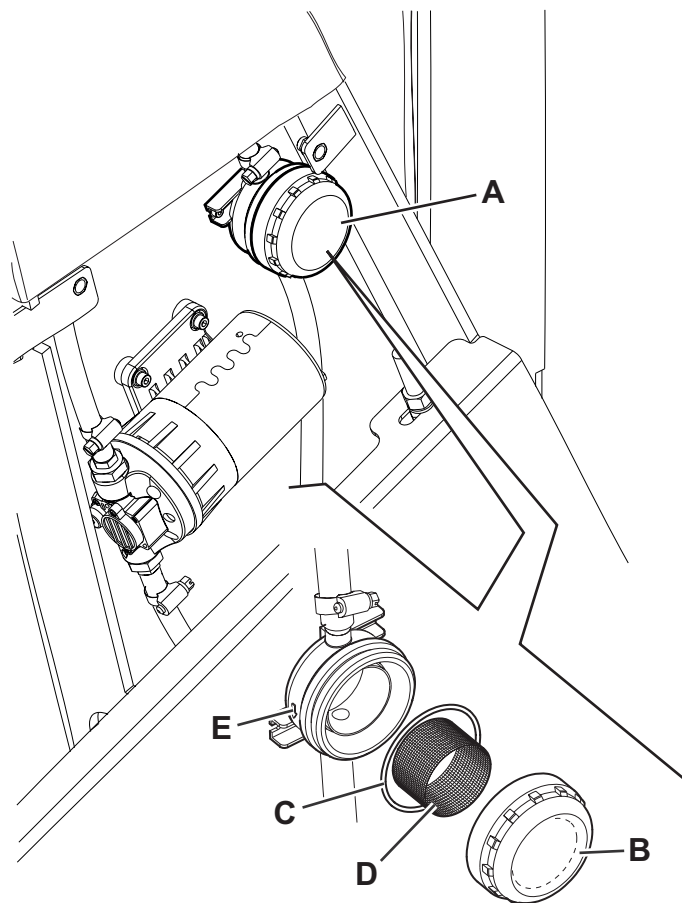

P100916

Figure 22

HYDRAULIC SYSTEM OIL LEVEL CHECK



WARNING!

Procedure to be performed with the hopper (11) fully retracted.

1. Turn the ignition key (51) to "0" and engage the parking brake.
2. Open the engine compartment hood (19) and fasten it with the support rod (44).
3. Check that the oil level in the hydraulic system tank (43) is between the minimum (MIN) and maximum (MAX) marks shown in figure 23.
4. If necessary, add oil through the plug (A), using the oil specified in Technical Data paragraph.
5. Remove the support rod (44) and close the hood (19).

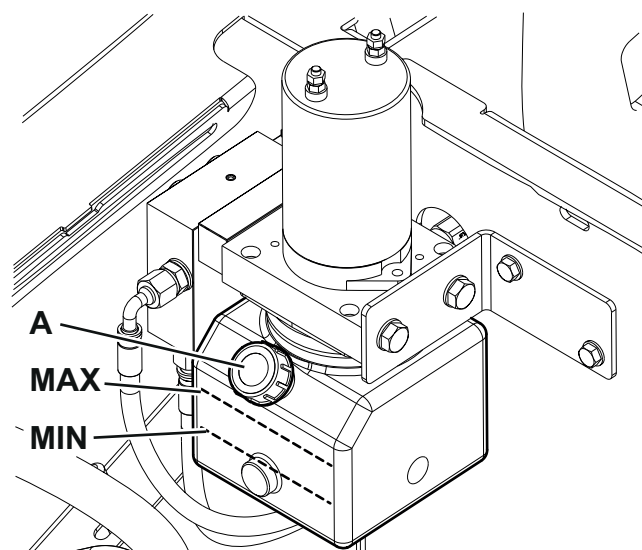

P100917

Figure 23

ENGINE OIL LEVEL CHECK AND REPLACEMENT**Engine oil level check****CAUTION!**

Running the engine with a low oil level can damage the engine itself.

**NOTE**

The oil alert system will automatically stop the engine before the oil level goes down under the safety limit. To avoid a sudden engine stop, always check the oil level before each start-up.

1. Drive the machine on a level ground and engage the parking brake.
2. Turn the ignition key (51) to "0".
3. Open the engine compartment hood (19) and fasten it with the support rod (44).
4. Lift and remove the right side panel (31).
5. Remove the cap (A, Fig. 24).
6. Check the oil level. If it is below the upper limit (E), top up with the recommended oil until you reach the upper limit.
7. Reinstall the filler cap (A) safely.

Engine oil change**CAUTION!**

The discharged engine oil must be disposed of properly according to the Law in force.

**NOTE**

It is advisable to change the oil when the engine is still hot, to make the oil downflow easier.

8. Perform steps 1 to 4 of the previous procedure.
9. Remove the cap (A, Fig. 24).
10. Unhook the drain hose (B) and bring it towards the outside of the machine.
11. Remove the drain plug (C) from the hose and drain the oil into a suitable container, then refit the oil drain plug and return the hose to its initial location.
12. Remove the filler cap (D) and pour in the new oil through the filler until it reaches the upper limit (E) of the cavity.

**NOTE**

As for engine oil type and quantity, see the Technical Data chapter and the Engine Manual.

13. Reinstall the filler cap (D) and the cap (A) safely.

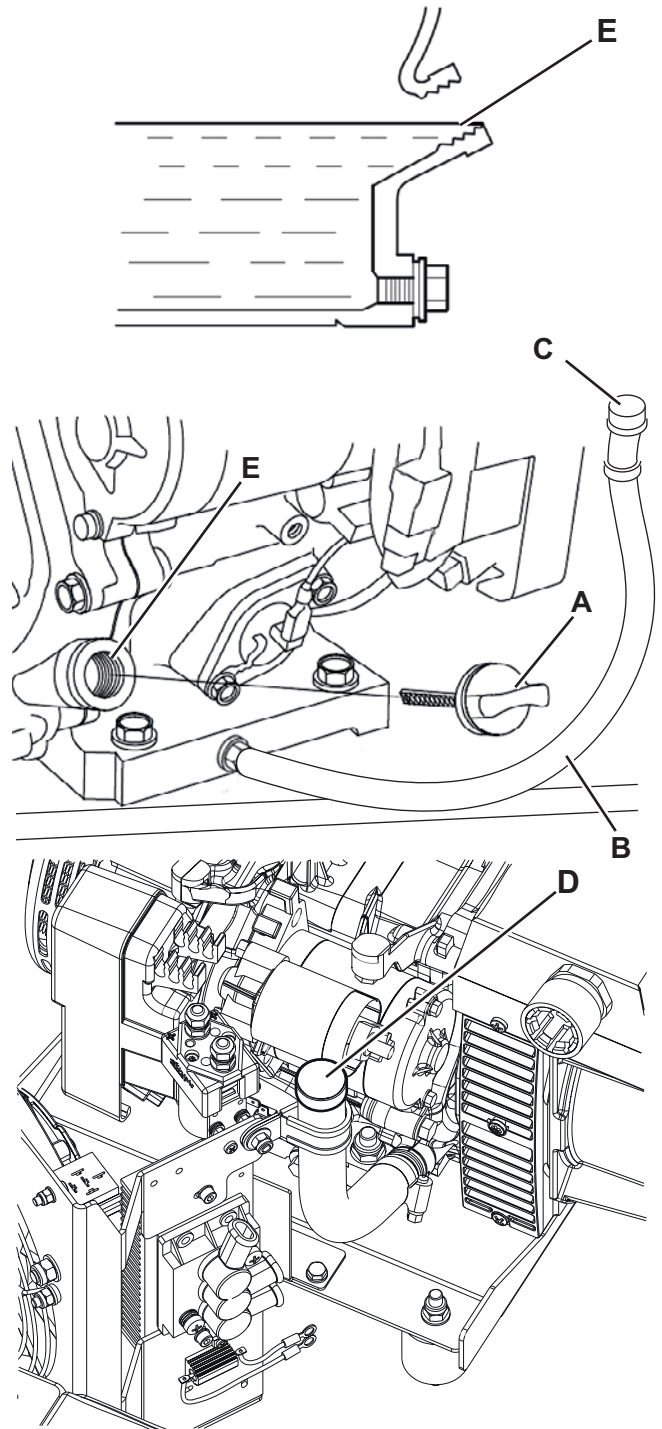
**Figure 24**

P100926

ENGINE AIR FILTER CHECK/CLEANING

A dirty air filter limits the passage of air, thus reducing engine performance. When working in particularly dusty areas, clean or replace the filters more often than specified in the maintenance program.



CAUTION!

Running the engine without air filters, or with damaged filters, can cause a faster engine wearing.

1. Drive the machine on a level ground and engage the parking brake.
2. Turn the ignition key (51) to "0".
3. Open the engine compartment hood (19) and fasten it with the support rod (44).
4. Lift and remove the right side panel (31).
5. Remove the wing nut (A, Fig. 25) and remove the cover (B).
6. Remove the wing nut (C) and disassemble the filter element.
7. Separate the paper filter (D) from the foam filter (E).
8. Check both filters and replace them if necessary. Replace the paper filter (D) when required (see the scheduled maintenance table).
9. To reuse the filters, clean them both by blowing compressed air [at no more than 207 kPa (2.1 kgf/cm)] inside the filter. Do not use a brush, otherwise the fiber will be damaged.
10. Clean with a wet cloth the base and the cover (B) of the air filter. Take care to prevent dirt entering the air duct (G).
11. Fit the foam filter (E) on the paper filter (D), then install the assembled filter element. Ensure that the gasket (F) is properly placed under the filter element. Screw down the filter element wing nut (C).
12. Install the cover (B) and screw down the wing nut (A).

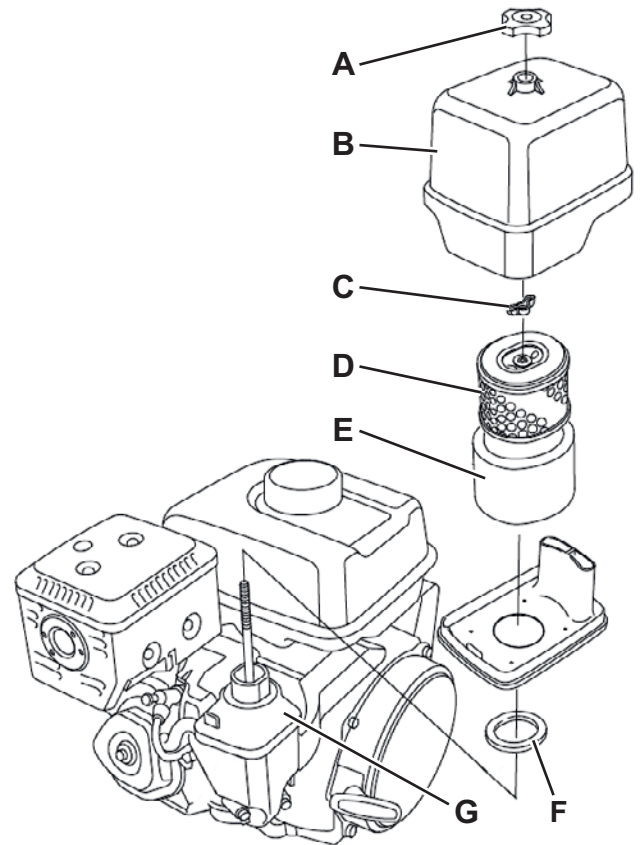

Figure 25

P100928

ENGINE SPARK PLUG CHECK/REPLACEMENT

For the type of spark plug to be used, see Technical Data chapter.

**CAUTION!**

A wrong spark plug can damage the engine.

1. Drive the machine on a level ground and engage the parking brake.
2. Turn the ignition key (51) to "0".
3. Open the engine compartment hood (19) and fasten it with the support rod (44).
4. Lift and remove the right side panel (31).
5. Disconnect the spark plug cap (A, Fig. 26) and remove dirt around the spark plug (B).
6. Remove the spark plug with a suitable wrench (C).
7. Check the spark plug. Replace it if it is damaged, dirty, if the sealing washer (D) is damaged or if the electrode is worn.
8. Measure the distance between the spark plug electrodes with a feeler gauge. Correct the distance by bending carefully the side electrode (E). The distance between the electrodes must be of 0.70 - 0.80 mm.
9. Install the spark plug manually with great care, to avoid tightening it improperly.
10. Once the spark plug is in place, tighten it with a proper wrench to press the sealing washer.
11. When a new spark plug is installed, tighten 1/2 turn once the spark plug is in place to press the washer.
12. When the original spark plug is reinstalled, tighten 1/8 - 1/4 turn once the spark plug is in place to press the washer.

**CAUTION!**

A loose spark plug can overheat and damage the engine.

Do not over-tighten, otherwise the threads in the cylinder head can be damaged.

13. Install the cap on the spark plug.

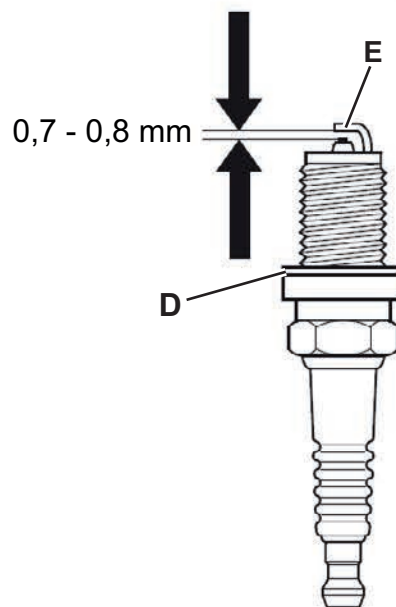
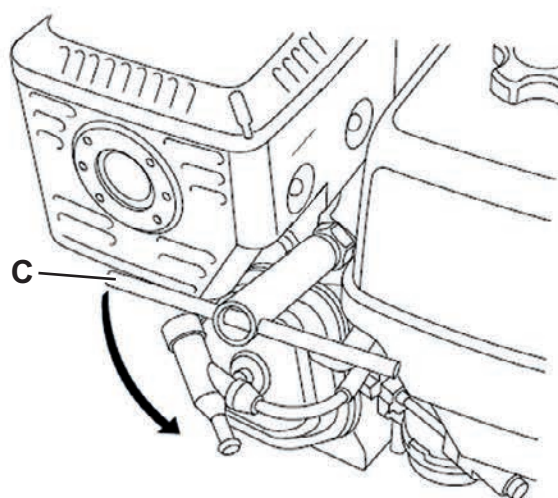
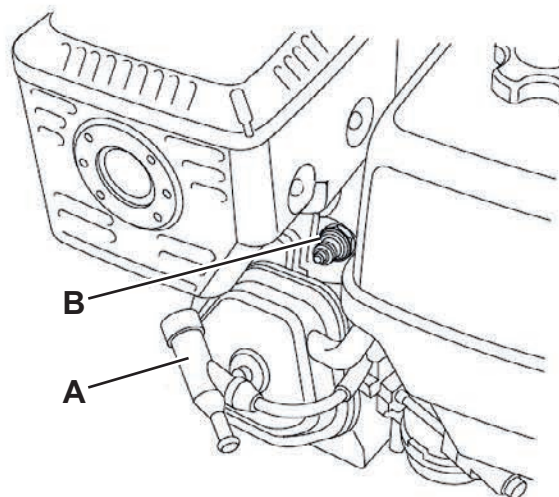



Figure 26

P100929

BATTERY CHARGING (only for version with optional hybrid KIT installed)**CAUTION!**

Charge the batteries with the installed battery charger when the last segment of the battery icon

(A, Fig. 27) starts flashing , or at the end of each job. Keeping the batteries charged make their life last longer.

Recharging is essential when the multifunction display shows screen (B).

**WARNING!**

When the batteries are discharged, charge them as soon as possible, as that condition makes their life shorter.

1. Drive the machine on a level ground and engage the parking brake.
2. Turn the ignition key (51) to "0".
3. Connect the battery charger plug (D) to a mains electrical socket.

**WARNING!**

Check that the voltage and frequency shown on the battery charger plate (D) match the mains supply values.

**NOTE**

When the battery charger is connected to the electrical mains, all machine functions are automatically cut off.

The multifunction display shows the screen (C) as in the figure.

4. When the battery charger green battery symbol (E) is flashing, the batteries are recharging.
5. When the battery charger green battery symbol (E) is lit steadily, the batteries are charged.
6. For further information about the battery charger operation, see the Battery Charger Manual.
7. Disconnect the battery charger cable from the electrical mains.

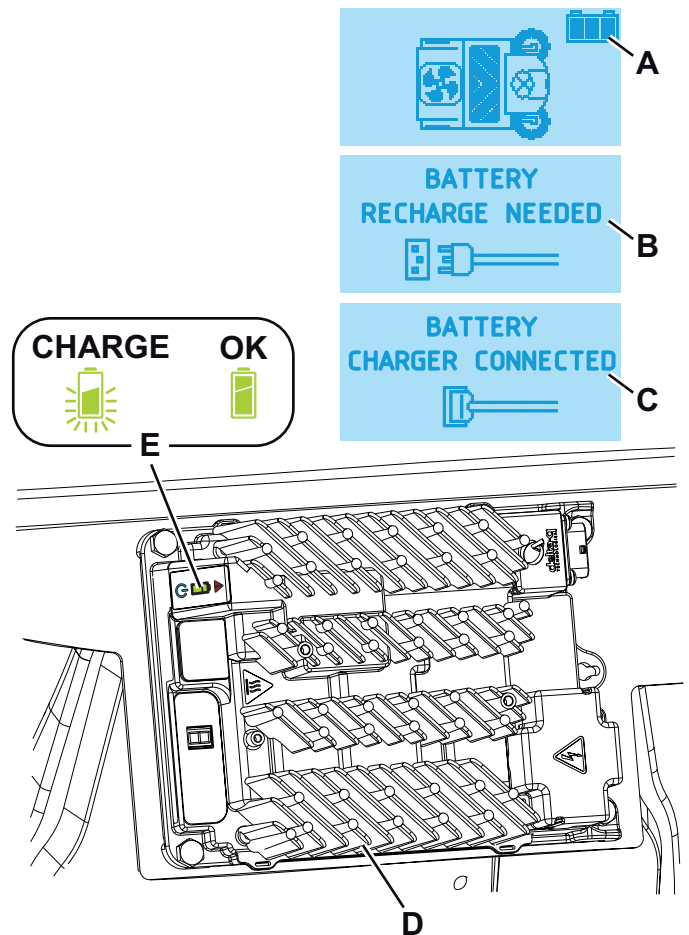
**Figure 27**

P100924

FUSE CHECK/REPLACEMENT



NOTE

All of the machine's electronic circuits are protected by electronic devices which reset automatically. The safety fuses blow only in the event of serious faults.

For this reason, fuses should only be replaced by qualified personnel.

Refer to the service manual available from Advance retailers.

SAFETY FUNCTIONS

The machine is equipped with the following safety functions.

EMERGENCY PUSH-BUTTON

It is to the left side of the operator (69). It has to be pressed in case of emergency, to stop all the machine functions.

DRIVER'S SEAT MICROSWITCH

This is located inside the driver's seat (3) and it does not allow the machine to operate if the operator is not seated on the driver's seat.

ANTI-SKID SAFETY SYSTEM

Reduces speed to a safe value, where necessary, when steering and when driving on a camber, in order to prevent skidding and increase the machine's stability in all operating conditions.

MACHINE ANGLE SENSOR

If the hopper is to be raised with the machine not on level ground, the system reduces the speed of movement of the hopper and warns the operator that the machine stability conditions may be critical depending on the weight of refuse contained, via a different buzzer sound and the icon on the display (71) as shown in figure 28.

HOPPER POSITION SENSOR

When the hopper is lifted, the sensor reduces the machine speed, turns off the vacuum fan and stops the broom rotation.

HOPPER SAFETY VALVE

When the hopper is lifted, the safety valve on the hydraulic lifting cylinder prevents the hopper to accidentally lower.

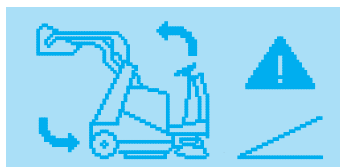



Figure 28

P100918

TROUBLESHOOTING

Trouble	Possible cause	Remedy
The engine does not start with the ignition key, or stops during work.	The fuel does not reach the engine.	Check that the tank safety valve is open.
	The spark plug does not produce a spark.	Check or replace the spark plug. (*)
	The batteries are discharged.	Recharge with a proper battery charger.
	The emergency push-button has been pressed.	Check and release the emergency push-button.
The engine does not start with the ignition key, or stops during work, and icon (71-R) appears on the multifunction display.	The engine oil level is too low.	Check the engine oil level and top up. (*)
The engine does not start with the ignition key, or stops during work, and icon (71-Q) appears on the multifunction display.	The temperature of the engine/alternator assembly is too high.	Wait for the engine to cool down before using the machine further. If possible, keep the hood open to facilitate cooling.
(For version with Hybrid Kit only) The machine operates only when stopped, but under load it shuts down and the  icon flashes.	The batteries are discharged.	Charge the batteries. If the trouble persists, replace the batteries.
(For version with hybrid Kit only) The batteries provide a short operating time.	Batteries no longer in good condition.	Replace the batteries. If necessary, install batteries of a higher capacity.
When turning the ignition key to "I", the display does not turn on and the machine does not operate.	Emergency push-button activated.	Check and release the emergency push-button.
The machine does not move when the accelerator pedal is pressed, and an alarm message appears on the display.	Accelerator pedal pressed, while the ignition key is turned to the "I" position.	Turn the ignition key to "0", then restart without pressing the accelerator pedal.
	The operator is not correctly seated on the driver's seat.	Sit down on the driver's seat.
	Drive system fault.	Turn off the machine and then turn it on again. If the trouble persists, contact the Service Center.
The machine does not move and the icon (71-S) appears on the multifunction display.	Engine off.	Switch on the engine.
	Alternator is faulty.	Contact the Service Centre.
The machine moves more slowly than usual.	Hopper not completely closed.	Return the hopper to the horizontal position and lower it completely.
	Machine started on a cambered surface and anti-skid system has lost correct reference.	Turn the machine off and then start it again on a flat surface.
The main broom does not work and the corresponding icon on the display does not appear.	The safety system has tripped.	Turn off the machine and then turn it on again. Check the condition of the main broom (debris that slows down the broom or excessive pressure on the ground).
The side brooms do not operate.	The safety system has activated.	Wait for the side broom motor to cool down, then reset the fuse by pressing the relevant push-button.
The machine collects little debris/dust.	The dust filter is clogged.	Clean the dust filter by using the filter shaker or by disassembling it.
	The hopper is full.	Empty the hopper.
	The skirts are not properly adjusted or are broken.	Adjust/replace the skirts.
	The brooms are not properly adjusted.	Adjust the broom height.
The hopper does not lift.	Hydraulic system oil level incorrect.	Check the hydraulic system oil level in the tank.
	Machine not level.	Bring the machine back to a level surface
The hopper does not dump.	The hopper is too low.	Lift the hopper at a minimum height of 350 mm.
The hopper does not lower.	Hydraulic oil taking too long to flow through the safety valve due to low temperature.	Wait a few moments to let the hydraulic system oil flow.
The filter shaker does not work.	Filter shaker disconnected.	Connect the filter shaker connector.

The dust guard system (optional) does not work.	Water tank empty.	Fill the tank.
	The nozzles or the water filter are clogged.	Clean.
	The pump is faulty.	Replace. (*)

(*) For the relevant instructions, see also to the Engine Manual.

(**) Procedure to be performed by Advance Service Center.

For further information, refer to the Service Manual, available at any Advance Service Center.

SCRAPPING

Have the machine scrapped by a qualified scrapper.

Before scrapping the machine, remove and separate the following materials, which must be disposed of properly according to the Law in force:

- Batteries
- Polyester dust filter
- Main and side brooms
- Hydraulic system oil
- Hydraulic system oil filter
- Plastic hoses and components
- Electrical and electronic components (*)

(*) Refer to the nearest Advance Center especially when scrapping electrical and electronic components.



9435 Winnetka Avenue North
Brookly Park, MN 55445
www.advance-us.com
Phone: 800-989-2235
Fax: 800-989-6566
©2016 Nilfisk, Inc.

A Nilfisk Brand