

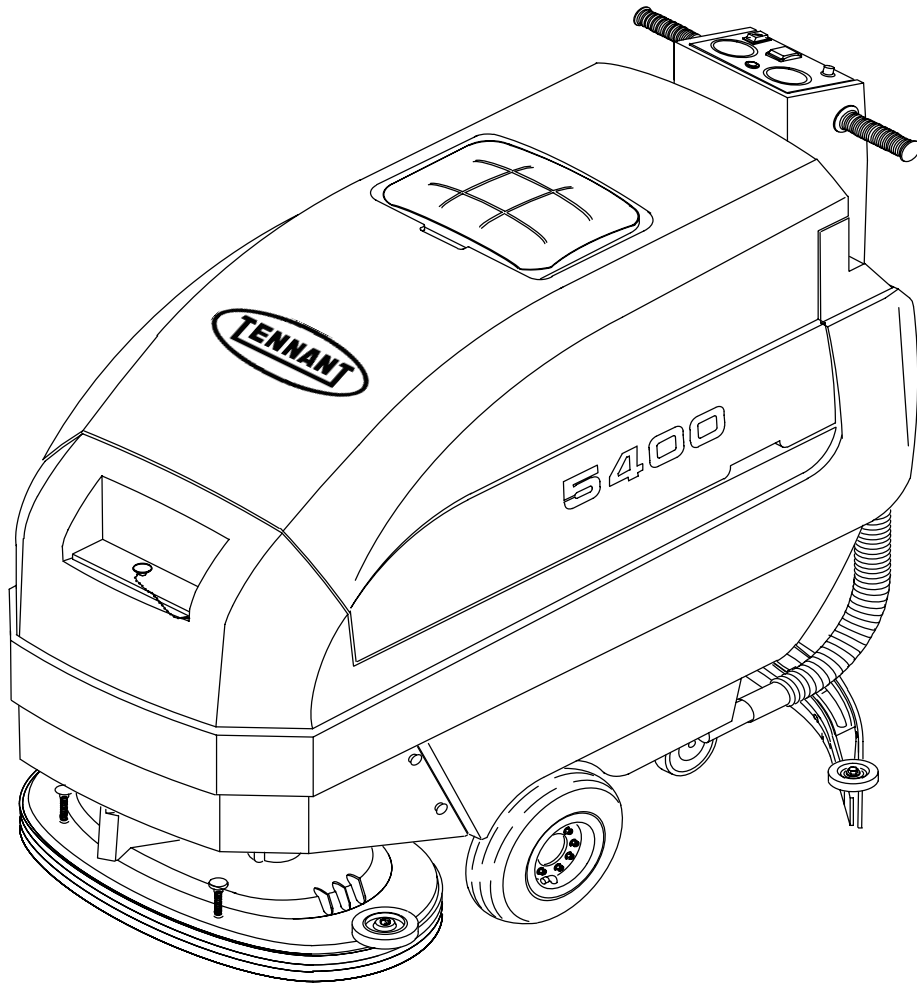

5400

Service Manual



330735
Rev. 00 (3-01)



This service manual is intended to be an aid for the disassembly and reassembly of your TENNANT Model 5400.

The set is organized into four major groups: General Information, Chassis, Scrubbing, and Electrical.

General Information: Machine safety, transport, jacking, lifting, and storage. Machine specifications, Maintenance charts and Hardware information.

Chassis: Tire/wheel replacement, Caster replacement, Transaxle and Transaxle drive motor replacement.

Scrubbing: Squeegee assembly replace and adjust, Scrubber head replace and adjust, Scrubber brush motor replacement, Vacuum fan replacement, Solution/recovery tank replacement, , Power wand pump replacement, and Scrubbing troubleshooting chart.

Electrical: Battery maintenance and replacement, Charging instructions, Circuit breaker/relay replacement, Instrument panel replacement, Vacuum fan motor brush replacement, Scrub brush brush replacement, Electrical schematic, and Electrical troubleshooting.

Manual Number – 330735

Revision: 00

Published: 3-01

CONTENTS

	Page
SAFETY PRECAUTIONS	1-3
SPECIFICATIONS	1-5
MACHINE DIMENSIONS – 610mm (24 in) and 660mm (26 in) DISK MODELS	1-6
MACHINE DIMENSIONS – 610mm (24 in) CYLINDRICAL BRUSH MODEL ...	1-7
TROUBLESHOOTING	1-8
MACHINE JACKING	1-10
MACHINE TRANSPORTING	1-10
STORING MACHINE	1-11
TO STORE MACHINE	1-11
STORAGE INFORMATION	1-11
HARDWARE INFORMATION	1-12
STANDARD BOLT TORQUE CHART	1-12
METRIC BOLT TORQUE CHART ...	1-12
BOLT IDENTIFICATION	1-12
THREAD SEALANT AND LOCKING COMPOUNDS	1-12

SAFETY PRECAUTIONS

This machine is intended for industrial and commercial use. It is suited to scrub hard floors in an indoor environment and is not constructed for any other use. Use only recommended pads, brushes and cleaning detergents.

The following safety alert symbols are used throughout this manual as indicated in their description.

⚠ WARNING: To warn of hazards or unsafe practices which could result in severe personal injury or death.

FOR SAFETY: To identify actions which must be followed for safe operation of equipment.

The following information signals potentially dangerous conditions to the operator or equipment:

FOR SAFETY:

1.. Do not operate machine:

- Unless trained and authorized.
- Unless operation manual is read and understood.
- In flammable or explosive areas unless designed for use in those areas.

2.. Before starting machine:

- Make sure all safety devices are in place and operate properly.

3.. When using machine:

- Go slow on inclines and slippery surfaces.
- Use care when reversing machine.
- Do not carry riders on machine.
- Always follow safety and traffic rules.
- Report machine damage or faulty operation immediately.

4.. Before leaving or servicing machine:

- Stop on level surface.
- Turn off machine.
- Set parking brake, if equipped.

5.. When servicing machine:

- Avoid moving parts. Do not wear loose jackets, shirts, or sleeves.
- Block machine tires before jacking machine up.
- Jack machine up at designated locations only. Block machine up with jack stands.
- Use hoist or jack of adequate capacity to lift machine.
- Wear eye and ear protection when using pressurized air or water.
- Disconnect battery connections before working on machine.
- Wear protective gloves when handling batteries or battery cables.
- Avoid contact with battery acid.
- Use manufacturer supplied or approved replacement parts.

⚠ WARNING: Batteries emit hydrogen gas. Explosion or fire can result. Keep sparks and open flame away. Keep covers open when charging.

⚠ WARNING: Flammable materials can cause an explosion or fire. Do not use flammable materials in tank(s).

⚠ WARNING: Flammable materials or reactive metals can cause explosion or fire. Do not pick up.

⚠ WARNING: Moving parts. Turn off power before working on machine.

⚠ WARNING: Actuator pinch point. Stay clear of head lift area.

GENERAL INFORMATION

The safety labels appear on the machine in the locations indicated. Replace labels if they become damaged or illegible.

BATTERY CHARGE LABEL –
LOCATED ON THE RECOVERY TANK
COVER AND BOTTOM SIDE OF
RECOVERY TANK.

⚠ WARNING: Batteries emit hydrogen gas. Explosion or fire can result. Keep sparks and open flame away. Keep covers open when charging.



FLAMMABLE MATERIALS LABEL –
LOCATED ON THE RECOVERY TANK
COVER.

⚠ WARNING: Flammable materials can cause an explosion or fire. Do not use flammable materials in tank(s). Flammable materials or reactive metals can cause explosion or fire. Do not pick up.

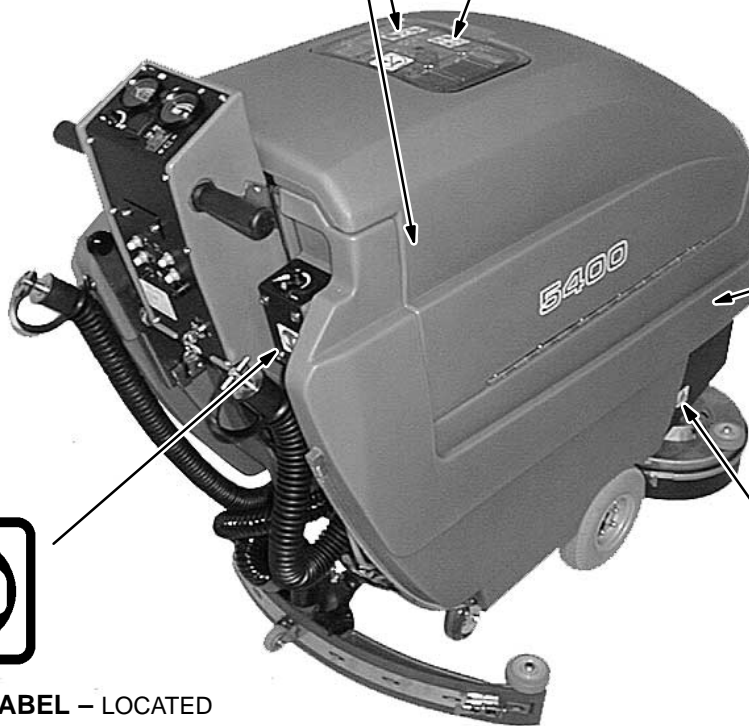

GENERAL HAZZARD LABEL – LOCATED ON THE ACTUATOR MOUNTING BRACKET

⚠ WARNING: Actuator pinch point. Stay clear of head lift area.

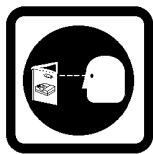

FOR SAFETY LABEL – LOCATED ON THE SOLUTION FLOW PANEL.

FOR SAFETY: Do not operate machine unless operation manual is read and understood.



MOVING PARTS LABEL – LOCATED ON THE SCRUB HEAD SHROUD.

⚠ WARNING: Moving parts. Turn off power before working on machine.

SPECIFICATIONS

MODEL	610mm (24 in) Disk Head	660mm (26 in) Disk Head	610mm (24 in) Cylindrical Head
LENGTH	1270mm (50 in)	1289mm (50.75 in)	1359mm (53.50 in)
WIDTH / WIDTH WITH SCRUB HEAD	559mm (22 in) / 641mm (25.25 in)	559mm (22 in) / 699mm (27.5 in)	559mm (22 in) / 667mm (26.25 in)
HEIGHT	1041mm (41 in)	1041mm (41 in)	1041mm (41 in)
WEIGHT	142 kg (314 lb) / 260 Kg (570 lb) with batteries	142 kg (314 lb) / 260 Kg (570 lb) with batteries	142 kg (314 lb) / 260 Kg (570 lb) with batteries
RECOVERY TANK CAPACITY	80 L (21 Gal)	80 L (21 Gal)	80 L (21 Gal)
SOLUTION TANK CAPACITY	80 L (21 Gal)	80 L (21 Gal)	80 L (21 Gal)
ES™ OPTION SOLUTION FILL CAPACITY	117 L (31 Gal)	117 L (31 Gal)	117 L (31 Gal)
DRIVE SYSTEM	Transaxle, 24 V, 19 kw (.25 hp)	Transaxle, 24 V, 19 kw (.25 hp)	Transaxle, 24 V, 19 kw (.25 hp)
CLEANING RATE	2415 m ² per hour (26,000 sq ft)	2601 m ² per hour (28,000 sq ft)	2415 m ² per hour (26,000 sq ft)
CLEANING PATH WIDTH	610mm (24 in)	660mm (26 in)	610mm (24 in)
PAD PRESSURE	Variable 0–54 kg (0–120 lb)	Variable 0–54 kg (0–120 lb)	Variable 0–41 kg (0–90 lb)
SQUEEGEE WIDTH	839mm (33 in)	839mm (33 in)	839mm (33 in)
TOTAL POWER CONSUMPTION	60 Amp nominal	60 Amp nominal	60 Amp nominal
BRUSH MOTOR	Two – .75 h.p., 270 rpm, 24 V, 33 A	Two – .75 h.p., 270 rpm, 24 V, 33 A	Two – .63 h.p., 1700 rpm, 670 brush rpm, 24 V, 23 A
VACUUM MOTOR	.75 h.p., 3–stage 5.7 in, 24 V, 21 A	.75 h.p., 3–stage 5.7 in, 24 V, 21 A	.75 h.p., 3–stage 5.7 in, 24 V, 21 A
WATER LIFT	1829mm (72 in)	1829mm (72 in)	1829mm (72 in)
BATTERIES	Four – 6 V, 235 AH	Four – 6 V, 235 AH	Four – 6 V, 235 AH
RUN TIME PER CHARGE	Up to 2.5 hours	Up to 2.5 hours	Up to 2.5 hours
DECIBEL RATING AT OPERATOR'S EAR, INDOORS ON TILE.	74 dB(A)	74 dB(A)	74 dB(A)

GENERAL INFORMATION

MACHINE DIMENSIONS – 610mm (24 in) and 660mm (26 in) DISK MODELS

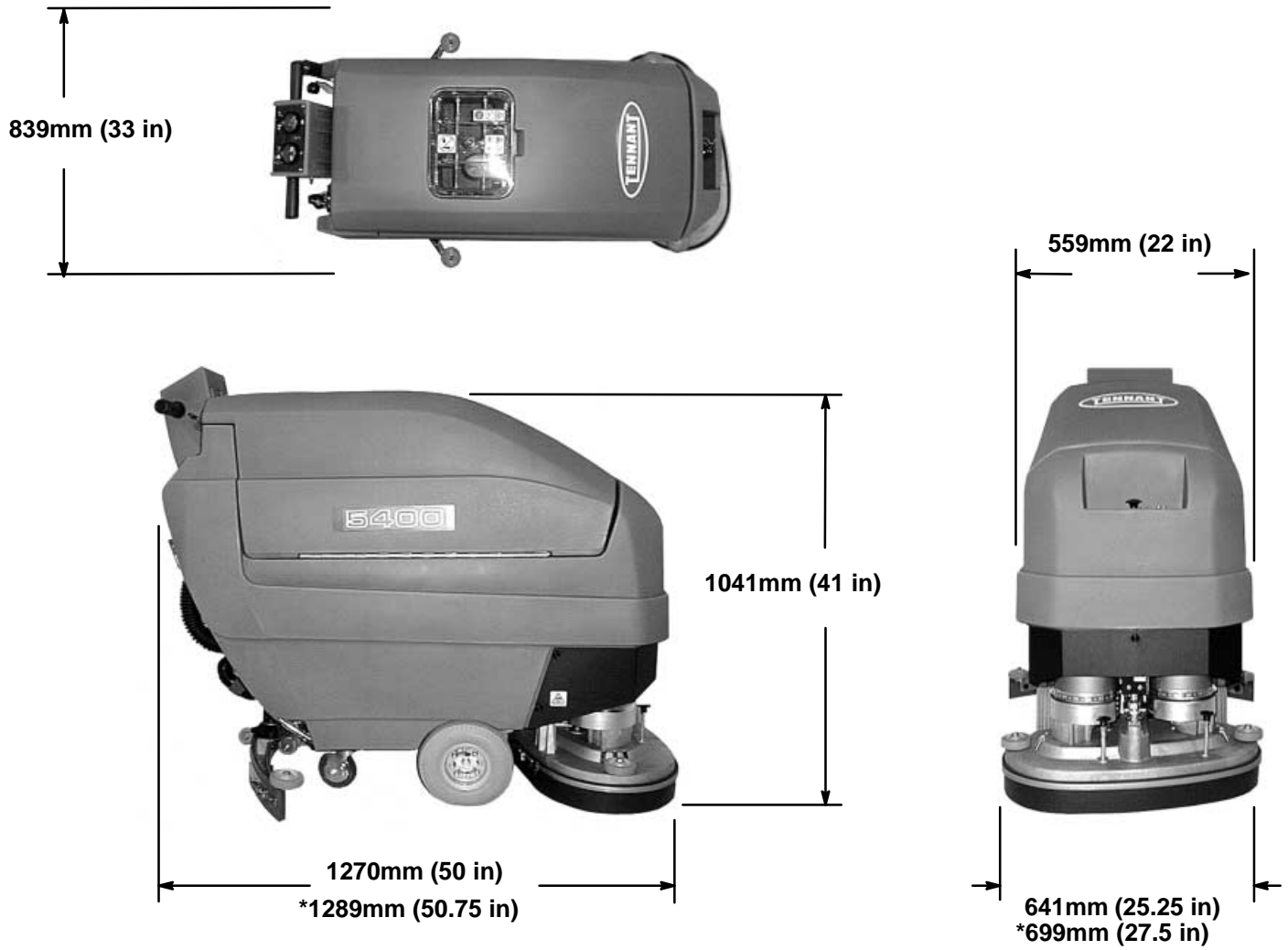

* Dimensions apply to 660 mm (26 in) disk models only

MACHINE DIMENSIONS – 610mm (24 in) CYLINDRICAL BRUSH MODEL

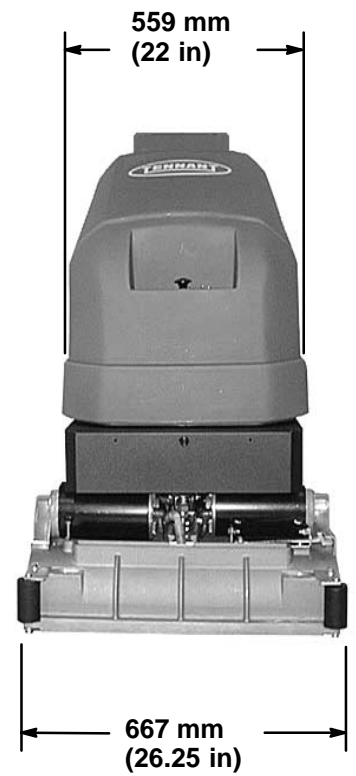
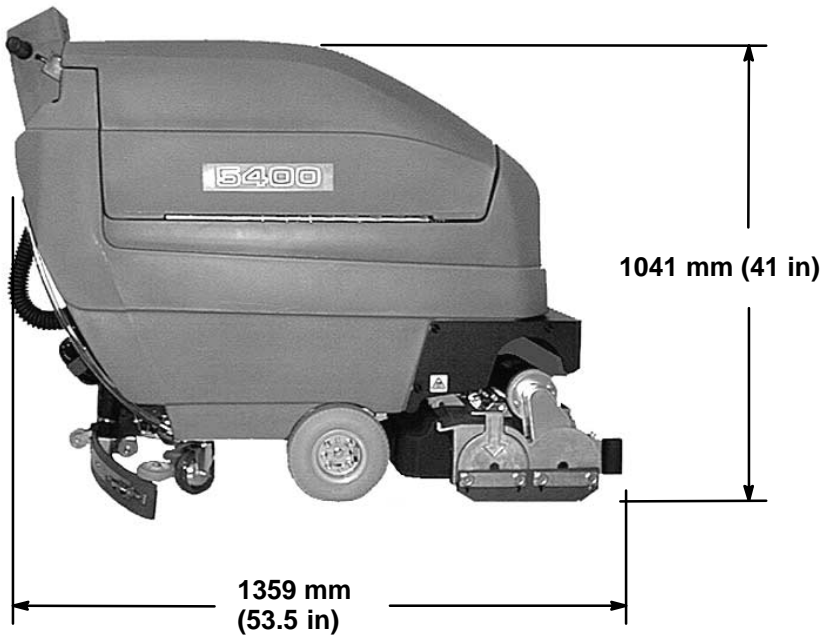
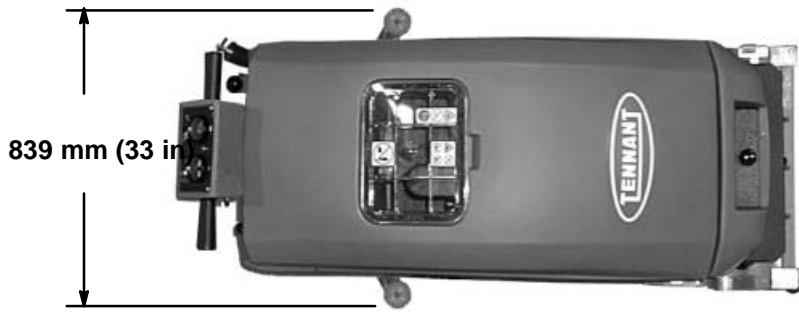

GENERAL INFORMATION

TROUBLESHOOTING

PROBLEM	CAUSE	SOLUTION
Machine will not turn on	Faulty key switch	Contact Service Center
	Batteries need charging	See CHARGING BATTERIES
	Faulty battery(s)	Replace battery(s)
	Loose battery cable	Tighten loose cable
	MAIN circuit breaker has tripped	Determine cause and reset breaker
	Optional power kill button activated	Turn button clockwise to reset
Brush motors will not turn on	Faulty brush switch	Contact Service Center
	Control grips not rotated	Rotate grips
	Brush circuit breaker has tripped	Replace pad or adjust pad pressure and reset brush circuit breaker button
	Faulty brush motor or wiring	Contact Service Center
	Worn carbon brushes	Contact Service Center
	Faulty brush solenoid	Contact Service Center
Vacuum motor will not turn on	Faulty vacuum switch	Contact Service Center
	Squeegee is raised off floor	Lower squeegee
	Main circuit breaker has tripped	Remove obstruction and reset circuit breaker button
	Vacuum motor circuit breaker has tripped	Determine cause and reset circuit breaker button
	Faulty vacuum motor or wiring	Contact Service Center
	Worn carbon brushes	Contact Service Center
Little or no solution flow	Solution switch is not activated	Turn on solution switch
	Clogged solution line or solution tank filter	Remove hose and blow compressed air through it. Flush solution tank after each use
	Clogged solution valve or solenoid	Remove valve or solenoid and clean. Do not scratch inside of valve
	Faulty solution switch or solenoid	Contact Service Center
	Solution flow knob not activated	Turn solution flow knob
	Loose set screw on solution knob	Calibrate knob and tighten screw
Poor Scrubbing Performance	Brushes/pads out of adjustment	See ADJUSTING SCRUB HEAD
	Worn Brushes/pads	Replace brushes/pads
	Debris caught in brushes/pads	Remove debris
	Low tire pressure	Increase tire pressure
	Low battery charge	Charge batteries
	Incorrect brush/pad pressure	Readjust brush/pad pressure
	Broken Brush belt (cylindrical brush)	Replace belts
Poor Drive Traction	Pad pressure set too high	Decrease brush pressure
	Tires slipping	Contact distributor for advice
	Uneven brush pressure	Level scrub head
	Broken brush belt (cylindrical brush)	Replace belt

TROUBLESHOOTING – Continued

PROBLEM	CAUSE	SOLUTION
Poor water pickup	Recovery tank is full and ball float has been activated	Empty recovery tank
	Ball float screen inside recovery tank is clogged	Remove screen and clean
	Clogged squeegee	Clean squeegee
	Worn squeegee blades	Replace squeegee blades
	Loose squeegee thumbscrews	Tighten thumbscrews
	Vacuum hose connections are loose or hose has a hole	Push hose cuffs firmly on connections. Replace hose if damaged
	Clogged vacuum hose	Remove clogged debris
	Recovery tank inlet hole is obstructed	Empty recovery tank and tilt tank sideways to access inlet hole, remove obstruction
	Worn tank lid gasket	Replace gasket
	Loose drain hose plug	Tighten plug
	Recovery tank lid not in place	Properly position lid
	Loose vacuum motor	Contact Service Center
	Battery charge level is low	Charge batteries. Do not run machine when battery meter is in the red zone
ES™ option not operating	ES™ filter is clogged	Remove and clean ES™ filter
	Faulty ES™ pump	Contact Service Center
	Faulty ES™ ON/OFF switch	Contact Service Center
	ES™ float switch is dirty	Rinse off float switch located in recovery tank
	Faulty ES™ float switch	Contact Service Center
Short run time	Batteries not fully charged	Charge batteries
	Defective batteries	Replace battery
	Batteries need maintenance	See BATTERY MAINTENANCE
	Faulty charger	Repair or replace battery charger

GENERAL INFORMATION

MACHINE JACKING

Use designated locations under the solution tank for jacking up machine. Use a piece of wood to distribute machine weight load.

Always stop machine on a flat level surface and block machine tires before jacking up machine.

FOR SAFETY: When servicing machine, block machine tires before jacking machine up.

FOR SAFETY: When servicing machine, jack machine up at designated locations only. Block machine up with jack stands.



MACHINE TRANSPORTING

FOR SAFETY: Before Leaving Or Servicing Machine; Stop On Level Surface, Set Parking Brake, Turn Off Machine And Remove Key.

FOR SAFETY: When using machine, go slow on inclines and slippery surfaces.

When transporting machine by use of trailer or truck, be certain to follow tie-down procedures below:

1. Raise squeegee and scrub head.
2. Load machine using a recommended loading ramp.
3. Position front of machine up against front of trailer or truck. Once machine is positioned, lower scrub head and squeegee.
4. Set parking brake, if equipped, and place a block behind each drive wheel to prevent machine from rolling.

STORING MACHINE

Before storing the machine for an extended period of time, the machine needs to be prepped to lessen the chance of rust, sludge, and other undesirable deposits from forming. Contact TENNANT service personnel.

TO STORE MACHINE

FOR SAFETY: Before Leaving Or Servicing Machine; Stop On Level Surface, Set Parking Brake, Turn Off Machine And Remove Key.

1. Make sure the tanks are drained and rinsed out.
2. Un-plug the batteries and charge them properly.

STORAGE INFORMATION

The following steps should be taken when storing the machine for extended periods of time.

1. Drain and clean the solution and recovery tanks.
2. Park the machine in a cool, dry area.
3. Remove the batteries, or charge them after every three months.

HARDWARE INFORMATION

The following charts state standard plated hardware tightening ranges for normal assembly applications. Decrease the specified torque by 20% when using a thread lubricant. Do not substitute lower grade hardware for higher grade hardware. If higher grade hardware than specified is substituted, tighten only to the specified hardware torque value to avoid damaging the threads of the part being threaded into, as when threading into speed nuts or weldments.

STANDARD BOLT TORQUE CHART

Thread Size	SAE Grade 5 Torque ft lb (Nm)	SAE Grade 8 Torque ft lb (Nm)
0.25 in	7–10 (9–14)	10–13 (14–38)
0.31 in	15–20 (20–27)	20–26 (27–35)
0.38 in	27–35 (37–47)	36–47 (49–64)
0.44 in	43–56 (58–76)	53–76 (72–103)
0.50 in	65–85 (88–115)	89–116 (121–157)
0.62 in	130–170 (176–231)	117–265 (159–359)
0.75 in	215–280 (291–380)	313–407 (424–552)
1.00 in	500–650 (678–881)	757–984 (1026–1334)

NOTE: Decrease torque by 20% when using a thread lubricant.

METRIC BOLT TORQUE CHART





Thread Size	Class 8.8 Torque ft lb (Nm)	Class 10.9 Torque ft lb (Nm)
M4	2 (3)	3 (4)
M5	4 (5)	6 (8)
M6	7 (9)	10 (14)
M8	18 (24)	25 (34)
M10	32 (43)	47 (64)
M12	58 (79)	83 (112)
M14	94 (127)	133 (180)
M16	144 (195)	196 (265)
M20	260 (352)	336 (455)
M24	470 (637)	664 (900)

NOTE: Decrease torque by 20% when using a thread lubricant.

Exceptions to the above chart:

Check the machine for exceptions!

BOLT IDENTIFICATION

Identification Grade Marking	Specification and Grade
	SAE–Grade 5
	SAE–Grade 8
	ISO–Grade 8.8
	ISO–Grade 10.9

01395

THREAD SEALANT AND LOCKING COMPOUNDS

Thread sealants and locking compounds may be used on this machine. They include the following:

Loctite 515 sealant – gasket forming material. TENNANT Part No. 75567, 15 oz (440 ml) cartridge.

Loctite 242 blue – medium strength thread locking compound. TENNANT Part No. 32676, 0.5 ml tube.

Loctite 271 red – high strength thread locking compound. TENNANT Part No. 19857, 0.5 ml tube.

CONTENTS

	Page
INTRODUCTION	2-3
DRIVE TRANSAXLE	2-4
TO REMOVE DRIVE TRANSAXLE ...	2-4
TO INSTALL THE TRANSAXLE	2-6
TO REPLACE DRIVE WHEEL/TIRE ASSEMBLY	2-7
REAR CASTER	2-9
TO REPLACE REAR CASTER	2-9

INTRODUCTION

This section includes information on the main chassis related components for example the transaxle, casters, and tires.

The transaxle drive motor and transaxle must be replaced as one unit.

CHASSIS

DRIVE TRANSAXLE

The drive transaxle on the 5400 provides the forward and reverse movement for the machine. The drive transaxle is powered by a 24V electric motor.

TO REMOVE DRIVE TRANSAXLE

1. Lower the scrub head all the way to the floor.

FOR SAFETY: Before Leaving Or Servicing Machine; Stop On Level Surface, Turn Off Machine.



2. Turn the machine power off.



3. Lift the rear of the machine until the transaxle drive wheels are off the ground.

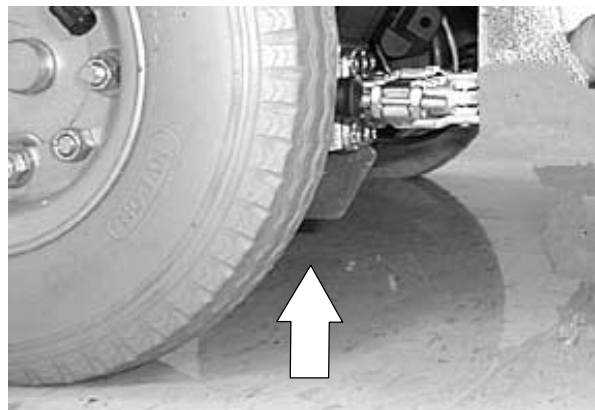

- Place a jackstand under the machine frame.



- Remove the four 0.250 in. hex nuts and washers holding each drive wheel to the transaxle. Remove the drive wheels from the machine.

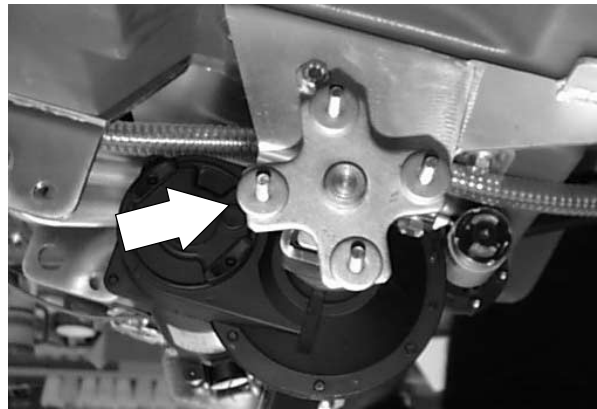

- Un-plug the transaxle drive motor from the main harness.

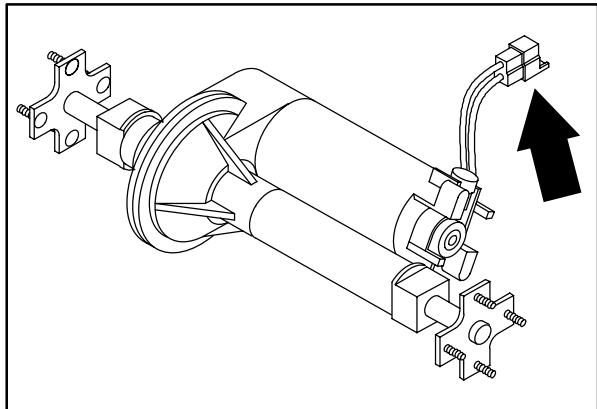

- Remove the four M8 hex screws and washers holding the two transaxle mount brackets to the machine frame.

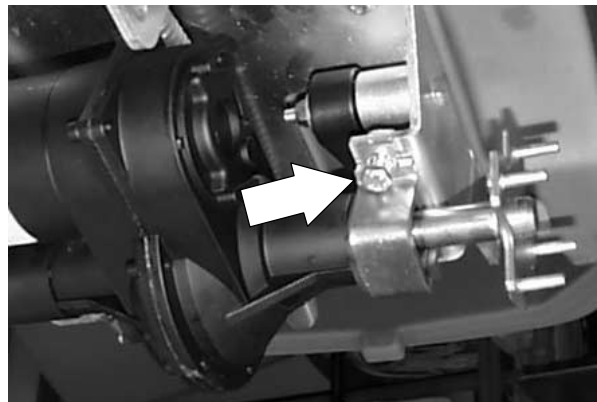

- The transaxle can now be removed from the machine.

CHASSIS

TO INSTALL THE TRANSAXLE

1. Position the new transaxle under the machine frame. Make sure the drive motor electric lead is positioned on the left hand side of the machine.

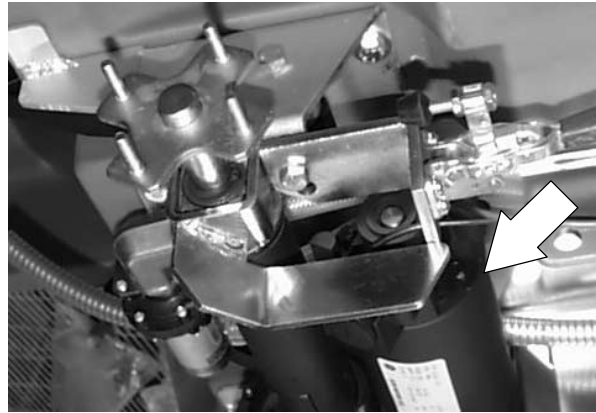

2. Lift the transaxle up into the machine frame until the mount brackets and M8 hex screws can be reinstalled. Tighten to 18 – 24 Nm (15 – 20 ft lb).

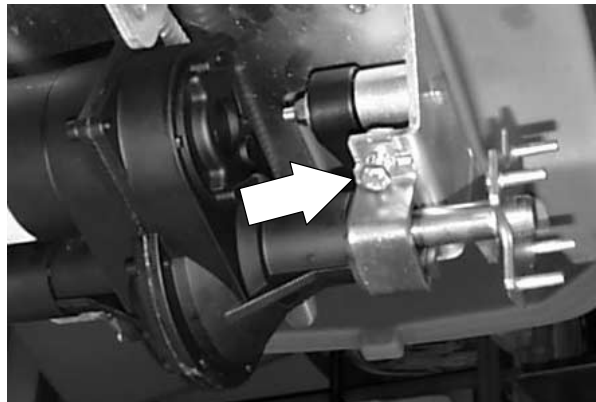

3. Plug the drive motor into the main harness. See schematic in the ELECTRICAL section of this manual.

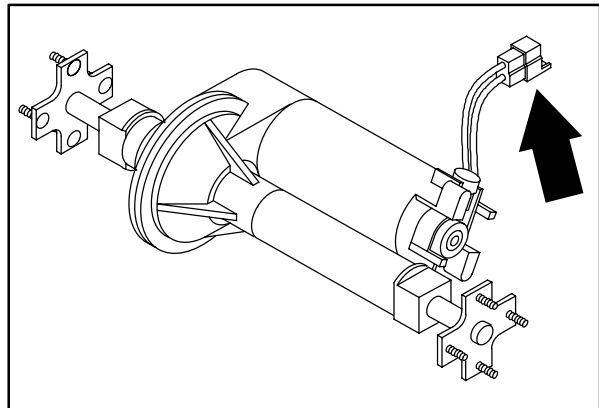

4. Reinstall the drive wheels onto the transaxle using the four 0.250 in. hex nuts and washers. Tighten to 11 – 14 Nm (7 – 10 ft lb).

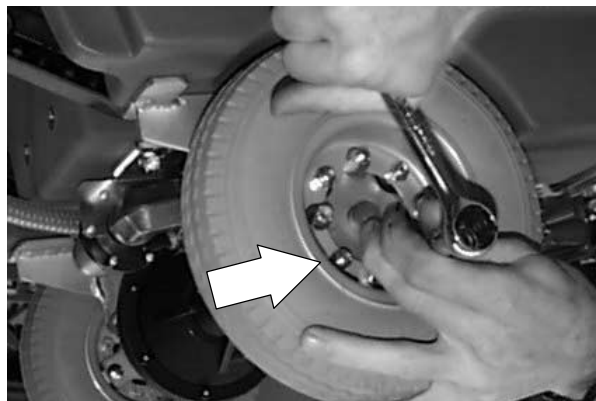

5. Remove the jack stands and lower the machine to the ground.
6. Raise the scrubber head.
7. Operate the machine, checking for proper operation of the transaxle.

TO REPLACE DRIVE WHEEL/TIRE ASSEMBLY

1. Lower the scrub head all the way to the floor.

FOR SAFETY: Before Leaving Or Servicing Machine; Stop On Level Surface, Turn Off Machine.



2. Turn the machine power off.



3. Lift the rear of the machine until the transaxle drive wheels are off the ground.

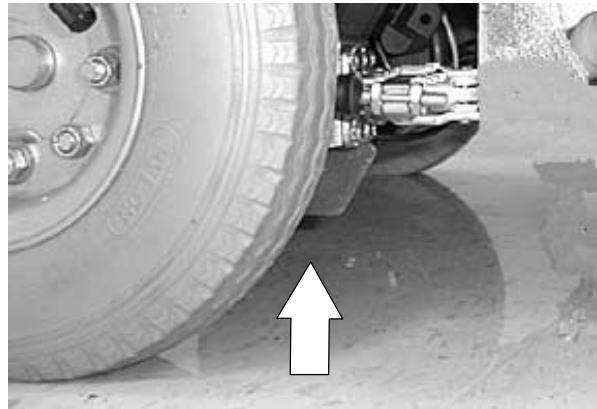

4. Place a jackstand under the machine frame.



CHASSIS

5. Remove the four 0.250 in. hex nuts and washers holding each drive wheel to the transaxle. Remove the drive wheels from the machine.
6. Position the new drive wheel onto the transaxle using the four 0.250 in. hex nuts and washers. Tighten to 11 – 14 Nm (7 – 10 ft lb).
7. Remove the jack stands and lower the machine to the ground.

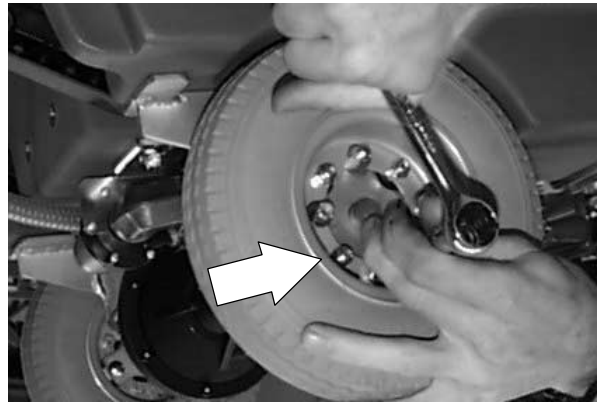

8. Raise the scrubber head.

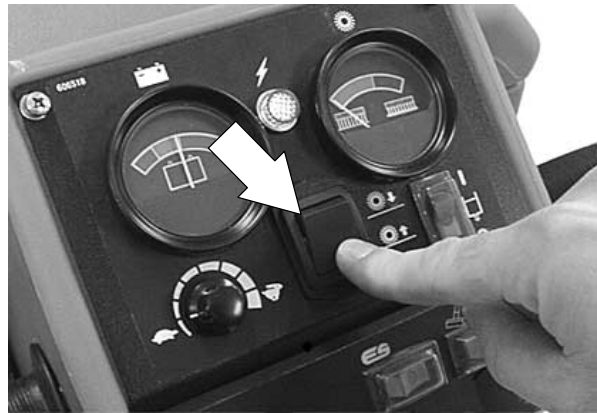

9. Operate the machine, checking for proper operation of the drive wheels.

CASTER

The casters have one grease fitting on the caster swivel. Lubricate the caster with a grease gun containing Lubriplate EMB grease every 80 hours of machine operation.

TO REPLACE CASTERS

FOR SAFETY: Before Leaving Or Servicing Machine; Stop On Level Surface, Turn Off Machine.

1. Turn the machine power off.



2. Lift the rear of the machine with an over head hoist or other lifting device until the rear caster is off the ground. Place a jackstand under the machine frame.



3. Remove the four M8 hex screws and washers holding the caster to the machine frame. Remove the caster from the machine.
4. Position the new caster under the machine and reinstall the four M8 hex screws and washers. Tighten to 18 – 24 Nm (15 – 20 ft lb).
5. Remove the jackstand from under machine frame. Lower the machine to the ground and operate, checking for proper operation.

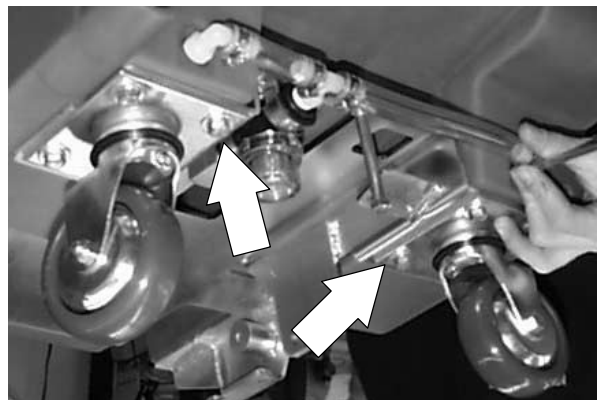

CONTENTS

	Page
INTRODUCTION	3-3
SOLUTION TANK	3-4
RECOVERY TANK	3-5
SCRUB BRUSHES	3-6
TO REPLACE DISC SCRUB BRUSH .	3-7
TO REPLACE CYLINDRICAL SCRUB BRUSH	3-8
SCRUB HEAD	3-10
TO REMOVE DISC SCRUB HEAD ..	3-11
TO ADJUST DISK BRUSH SCRUB HEAD	3-13
TO REPLACE DISK SCRUB HEAD SKIRT	3-14
TO REMOVE CYLINDRICAL SCRUB HEAD	3-15
TO CHECK CYLINDRICAL BRUSH PATTERN	3-17
TO ADJUST TAPERED BRUSH PATTERN	3-20
TO ADJUST UNEVEN BRUSH PATTERN	3-22
TO ADJUST CYLINDRICAL SCRUB HEAD SKIRTS	3-23
TO REPLACE CYLINDRICAL SCRUB HEAD SKIRT	3-25
TO REPLACE CYLINDRICAL SCRUB BRUSH DRIVE BELT	3-26
TO REPLACE CYLINDRICAL SCRUB BRUSH IDLER PLUG AND BEARING ASSEMBLY	3-29
TO REPLACE CYLINDRICAL SCRUB BRUSH DRIVE PLUG BEARINGS	3-31
SQUEEGEE	3-37
TO REMOVE SQUEEGEE	3-37
TO REPLACE OR ROTATE REAR SQUEEGEE BLADE	3-39
TO REPLACE OR ROTATE FRONT SQUEEGEE BLADE	3-40
TO REPLACE SQUEEGEE LIFT CABLE	3-41
TO REPLACE SOLUTION FLOW CONTROL CABLE	3-43
MACHINE TROUBLESHOOTING	3-45

INTRODUCTION

When scrubbing with the 5400, the water flows from the solution tank, through the solution valve, and down to the scrub head. The brush scrubs the floor. As the machine moves forward the squeegee wipes the dirty solution off the floor, which is then picked up and drawn into the recovery tank by the vacuum fan.

This section includes information on the scrub head, scrub brush, squeegee, lift actuator, vacuum fan, float switches, and solution tanks.

SCRUBBING

SOLUTION TANK

The solution tank holds the clean water and detergent mixture that will be applied to the floor for the scrubbing operation. The solution tank is also the main frame component.



The solution tank does not require regular maintenance except daily rinsing of any sludge or deposits. If any deposits do form on the bottom of the tank, rinse with a strong blast of warm water.

NOTE: The water must not be hotter than 60° C (140° F), or tank damage may occur. Do not use steam to clean the tank.

ES™ Option: The recovery tank should be partially filled with clean water after using the ES™ Option and clean water should be run through the pump until it is clear of any deposits.



RECOVERY TANK

The recovery tank holds the used water and detergent solution pulled off the floor by the squeegee and scrubbing vacuum fan. The recovery tank is the top tank on the machine. It can be opened for battery, vacuum fan, head lift actuator and water valve access.

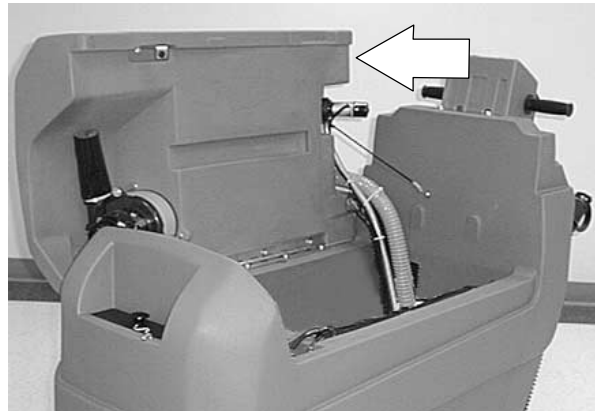

The recovery tank should be drained and cleaned daily.

*NOTE: The water must not be hotter than 60° C (140° F), or tank damage may occur. **Do not** use steam to clean the tank.*



SCRUBBING

SCRUB BRUSHES

The scrub brushes should be checked daily for wire or string tangled around the brush or brush drive hub. The brushes should also be checked for any damage and wear.

The scrub brush should be replaced if large amounts of bristles are missing, or if the remaining bristles' length is less than 10 mm (0.38 in).

NOTE: Be sure to replace brushes in sets. Otherwise one brush will be more aggressive than the other.



Cleaning pads must be placed on pad drives before they are ready to use. The cleaning pad is held in place by a pad holder.

Cleaning pads need to be cleaned with soap and water after every use.

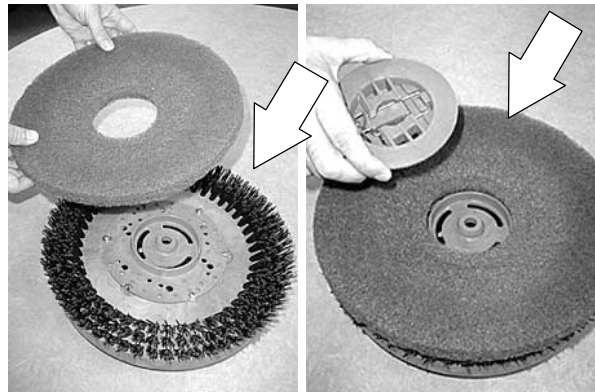

TO REPLACE DISC SCRUB BRUSH

1. Make sure the scrub head is in the raised position.

FOR SAFETY: Before Leaving Or Servicing Machine; Stop On Level Surface, Turn Off Machine.



2. Turn the machine off.



3. Push the brush release knobs downward.

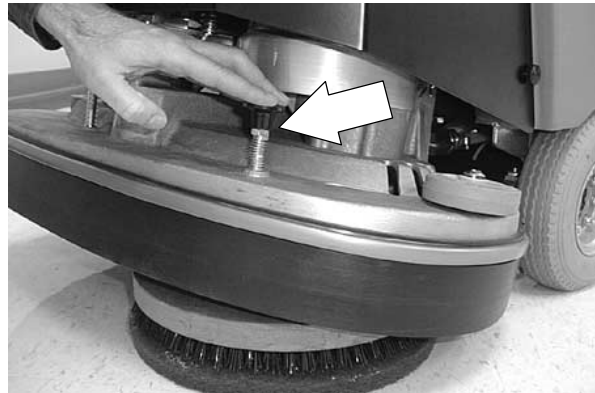

4. Remove the brush from the drive plug. Pull the brush out from under the scrub head.

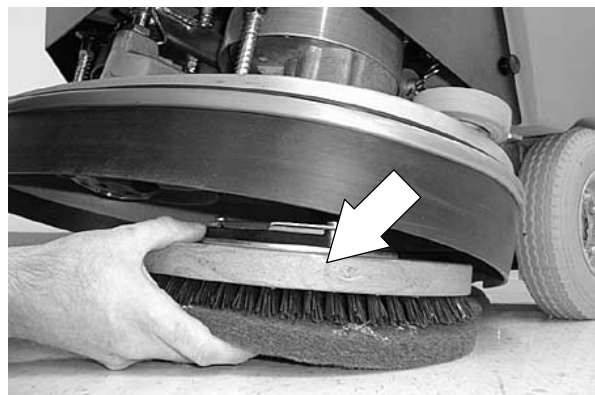

5. Reverse this order for installing the disc scrub brush

SCRUBBING

TO REPLACE CYLINDRICAL SCRUB BRUSH

1. Make sure the scrub head is in the raised position.

FOR SAFETY: Before Leaving Or Servicing Machine; Stop On Level Surface, Turn Off Machine.



2. Turn the machine off.



3. The cylindrical scrub brush must be removed from the end of the scrub head opposite the brush drive motor.

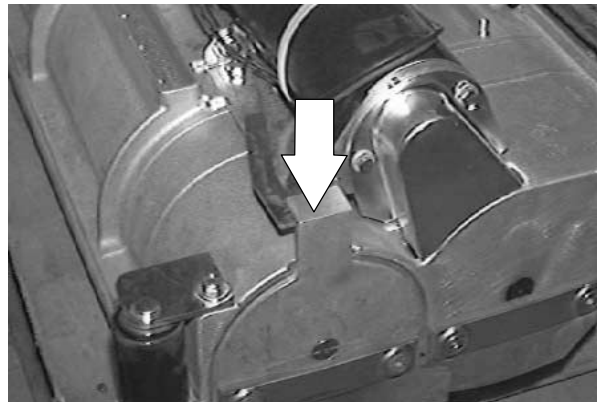

4. The brush idler plate is held in place with a spring clip. To remove the idler plate the spring clip must be pressed down flat to the top of the scrub head.



5. With the spring clip pressed down flat to the top of the scrub head, pull the bottom of the idler plate out of the end of the brush and off the spring clip.



6. The scrub brush can now be removed from the machine.
7. Position the new scrub brush under the scrub head.

NOTE: One end of the cylindrical scrub brush has a double row of bristles. This end must be on the idler side of the scrub head.

8. Place the brush on the motor-drive end first.
9. Partially engage the idler plug into the other end of the scrub brush.
10. Position the idler plate on the scrub head, making sure that the notches on the idler plate engage the lip of the scrub head.

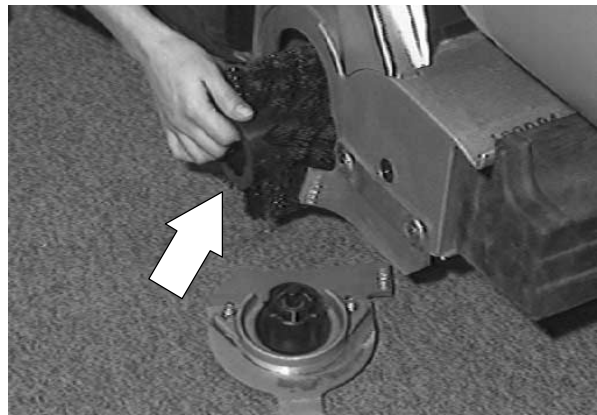

11. Push the spring clip down until the slot is positioned under the clip on the idler plate. Release the spring.
12. Start the brushes and check for proper brush pattern. See TO CHECK CYLINDRICAL BRUSH PATTERN instructions.

Note: Every 50 hours the front brush should be installed in the rear and the rear brush installed in the front to keep an even wear pattern on the bristles.

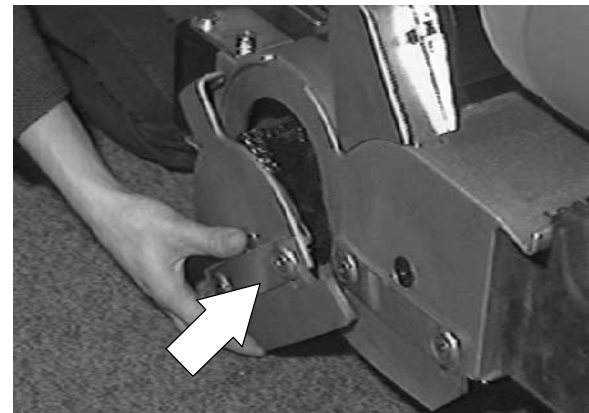

SCRUBBING

SCRUB HEAD

The scrub head includes the scrub brushes, electric motors, lift actuator and a solution dispensing system. The scrub head skirt controls over-spray from the scrub brush. Make sure the scrub head skirt touches the floor all the way around when the scrub head is lowered.

Check the disk brush scrub head skirt for damage or wear daily.



Check the cylindrical brush scrub head side skirt for damage daily.

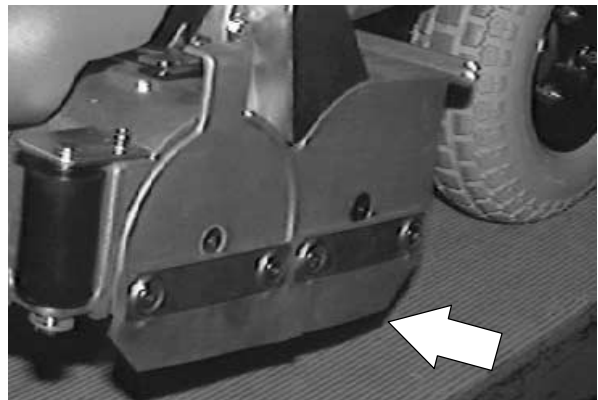

TO REMOVE DISC SCRUB HEAD

1. Lower the scrub head to the floor.

FOR SAFETY: Before Leaving Or Servicing Machine; Stop On Level Surface, Set Parking Brake, Turn Off Machine And Remove Key.



2. Remove the scrub head shroud.

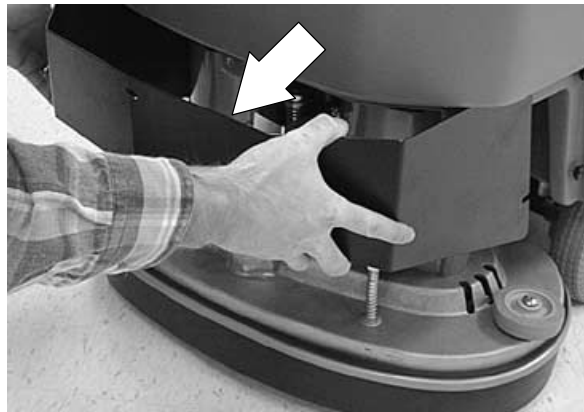

3. Disconnect the solution hose running from the solution tank to the scrub head.

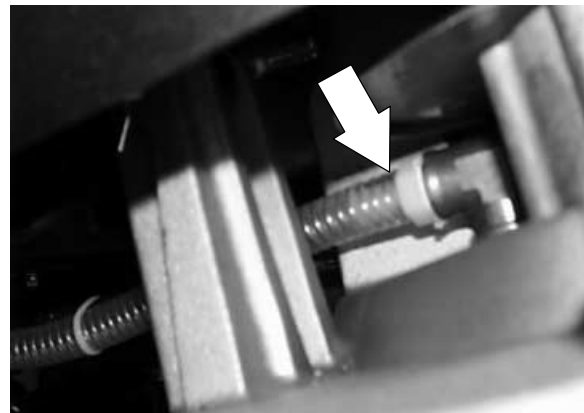

4. Unplug the electrical connectors attaching the scrub head motor to the main harness.



SCRUBBING

5. Remove the cotter pin and clevis pin from the bottom of the head lift roller bracket.

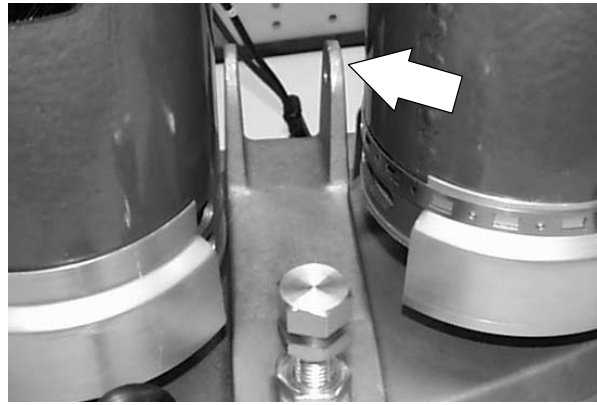

6. Remove the two hair pins and two clevis pins connecting the scrub head to the scrub head lift arms.



7. Pull the disc scrub head away from the front of the machine.

8. Reverse these steps to *install* a disc scrub head.

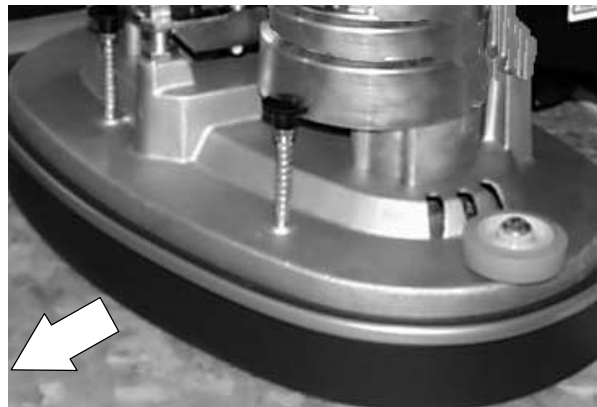

NOTE: When reinstalling a scrub head, loosen the two mounting screws on the switch box. Align the corresponding arrow printed on the switchbox label with the notch in the spring bracket.

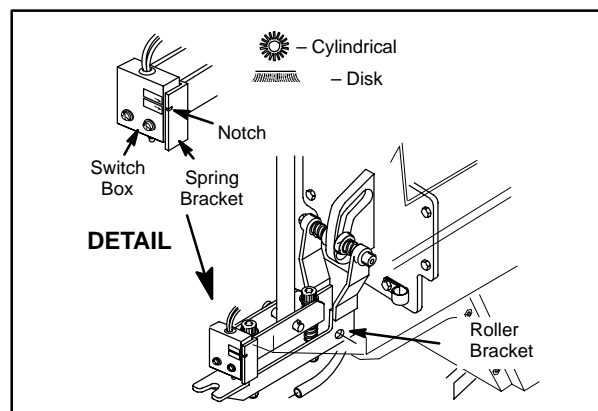

TO ADJUST DISK BRUSH SCRUB HEAD

1. Check the air pressure in the drive tires.
Proper air pressure for standard pneumatic tire is 315 to 345 kPa (45 to 50 psi).

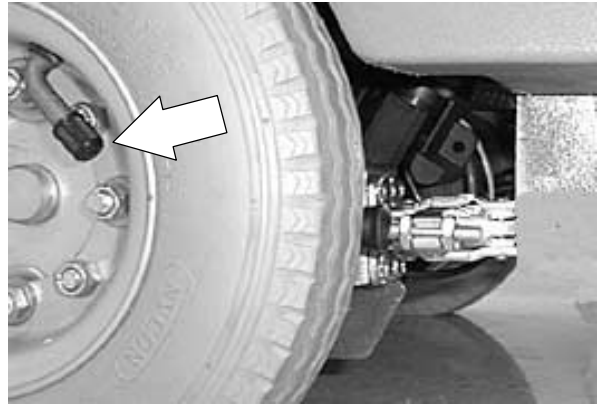

2. Fill the solution tank.



3. Lower the scrub head to the floor .
Apply maximum down pressure.

FOR SAFETY: Before Leaving Or Servicing Machine; Stop On Level Surface, Set Parking Brake, Turn Off Machine And Remove Key.



4. The scrub head levelness is checked by measuring from the top of the scrub head to the floor at the center front and center back.

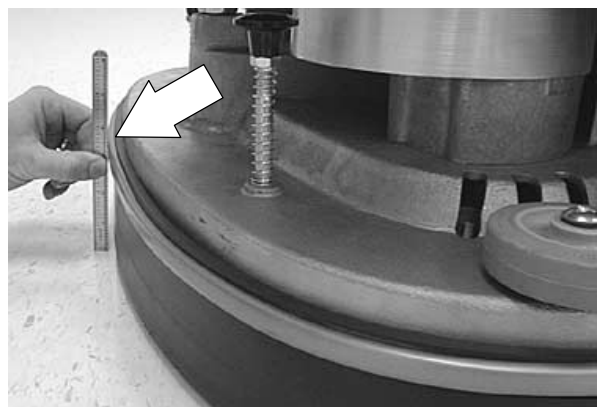

SCRUBBING

5. If the scrub head is not level, loosen the scrub head adjustment screw jam nut. Use a 1 inch open end wrench on the adjustment hex screw, located at the front of the pivot bracket, to adjust the angle of the scrub head. Make sure to re-tighten the jam nut. *Re-check the scrub head levelness.*

NOTE: Make sure the scrub head skirt touches the floor all the way around when the scrub head is lowered. Check the skirt for damage or wear daily.

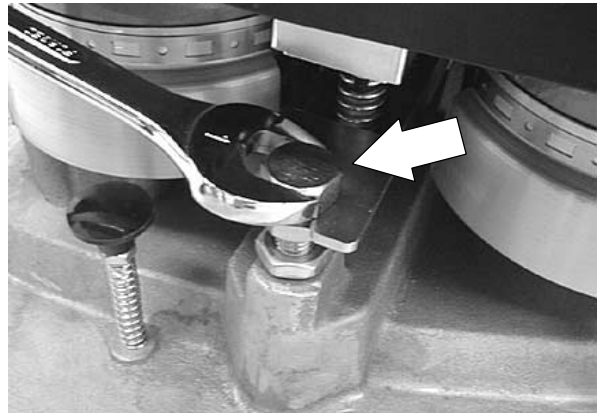

TO REPLACE DISK SCRUB HEAD SKIRT

1. If the disc scrub head skirt is torn or worn, it needs to be replaced. Remove the skirt retaining band and skid strip holding the skirt to the head.

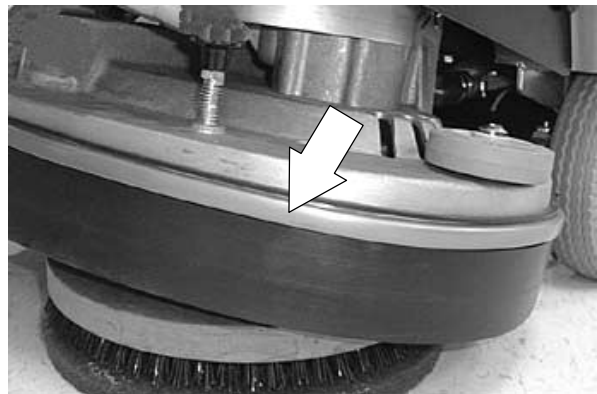

TO REMOVE CYLINDRICAL SCRUB HEAD

1. Lower the scrub head to the floor.

FOR SAFETY: Before Leaving Or Servicing Machine; Stop On Level Surface, Set Parking Brake, Turn Off Machine And Remove Key.



2. Remove the scrub head shroud.

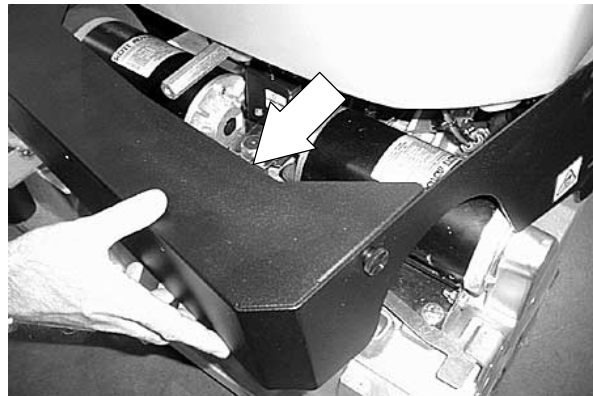

3. Disconnect the solution hose running from the solution tank to the scrub head.

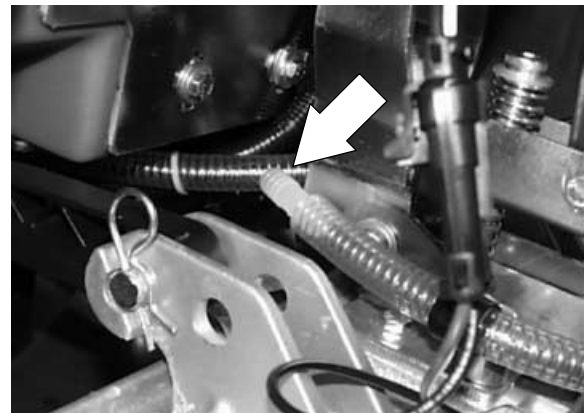

4. Unplug the electrical connectors attaching the scrub head motors to the main harness.

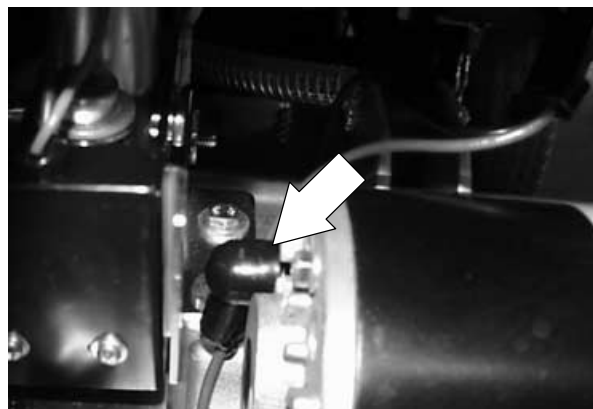

SCRUBBING

5. Remove the socket screw connecting the back of the scrub head to the head lift roller bracket.

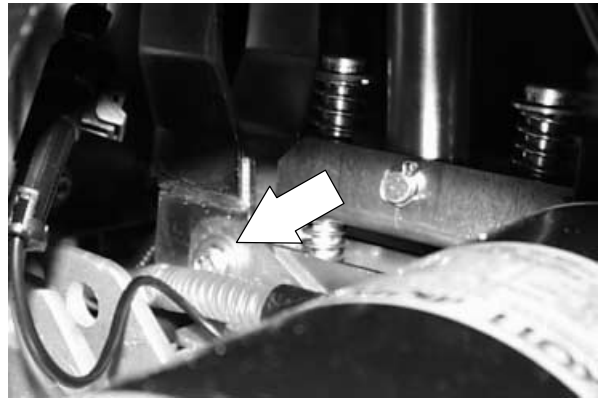

6. Remove the two hair pins and two clevis pins connecting the scrub head to the scrub head lift arms.

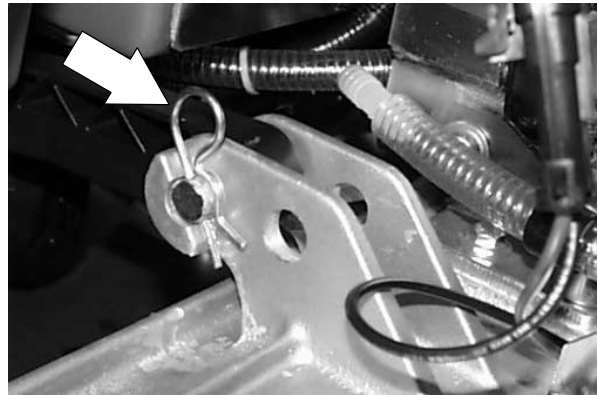

7. Pull the disc scrub head away from the front of the machine.

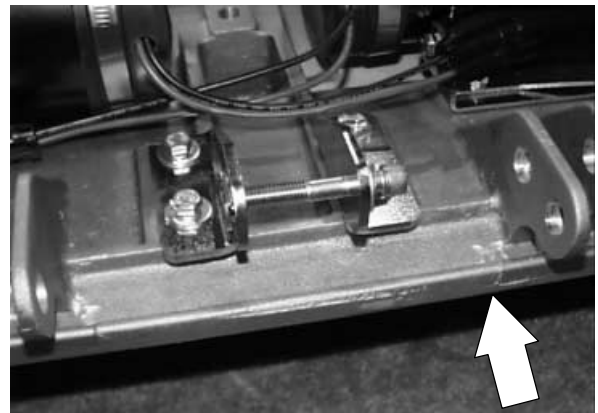

8. Reverse these steps to *install* a cylindrical scrub head. After installing scrub head, see TO CHECK CYLINDRICAL BRUSH PATTERN instructions.

NOTE: When reinstalling a scrub head, loosen the two mounting screws on the switch box. Align the corresponding arrow printed on the switchbox label with the notch in the spring bracket.

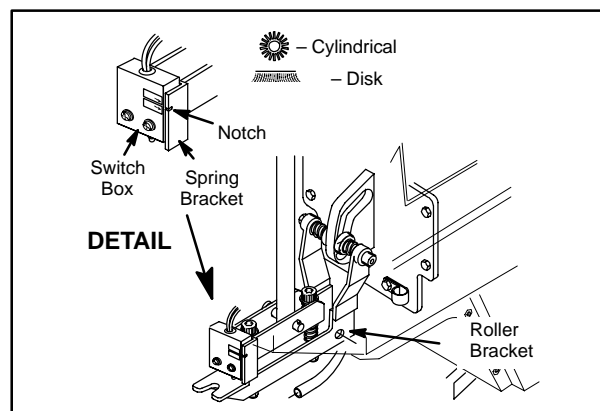

TO CHECK CYLINDRICAL BRUSH PATTERN

Apply chalk, or some other material that will not blow away easily, on a smooth, level floor.

1. Check the air pressure in the drive tires.
Proper air pressure for standard pneumatic tire is 315 to 345 kPa (45 to 50 psi).

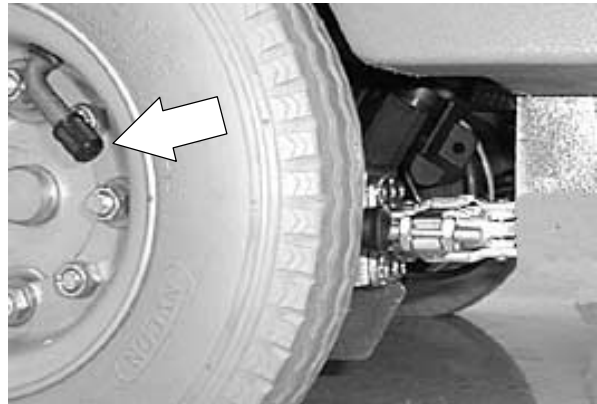

2. Fill the solution tank.



3. Position the machine with the scrub head located over the top of the chalk area.
Lower the scrub head to the floor .
Apply minimal down pressure.

FOR SAFETY: Before Leaving Or Servicing Machine; Stop On Level Surface, Set Parking Brake, Turn Off Machine And Remove Key.



SCRUBBING

4. Turn the solution switch to the off position.

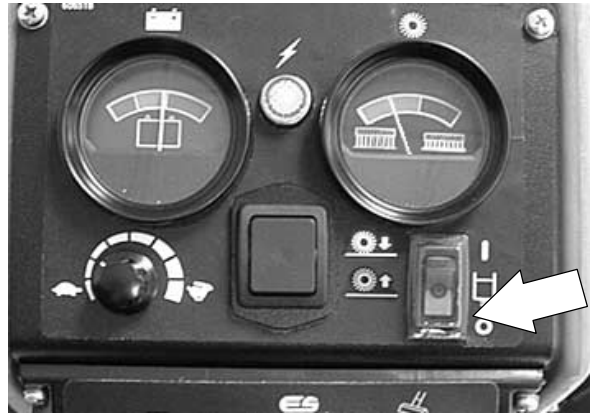

5. Turn the speed control knob to the slowest setting.



NOTE: Make sure the side skirts on the scrub head are not holding the scrub head and brushes up off the floor when checking the brush pattern. You may have to adjust them up or pull them to the side.

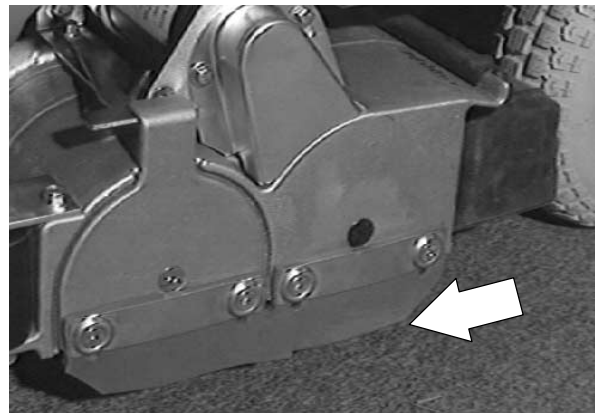

6. Slightly rotate the control grips forward for 2 seconds while holding the machine in one spot. Lower the scrub head, allowing the brushes to spin on the floor in one spot for 15 to 20 seconds.

NOTE: If no chalk or other material is available, allow the brushes to spin for 30 seconds in one spot.



7. Raise the scrub head and drive the machine from the test area. Check both brush patterns to make sure they are the same width from side to side. If both brush patterns look good, the adjustment procedure is complete. If either brush shows a tapered pattern, see TO ADJUST TAPERED BRUSH PATTERN instructions. If either brush shows an uneven pattern, see TO ADJUST UNEVEN BRUSH PATTERN instructions.

Good pattern

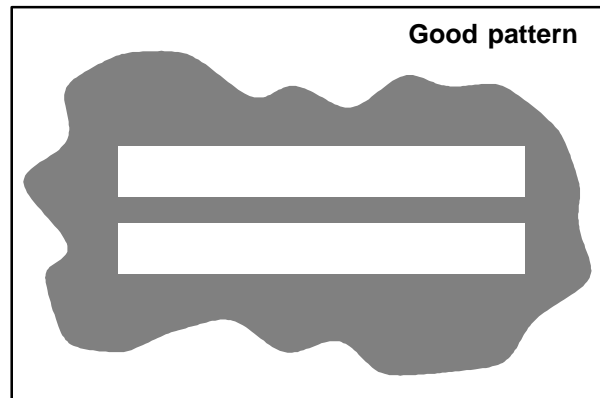

Tapered pattern

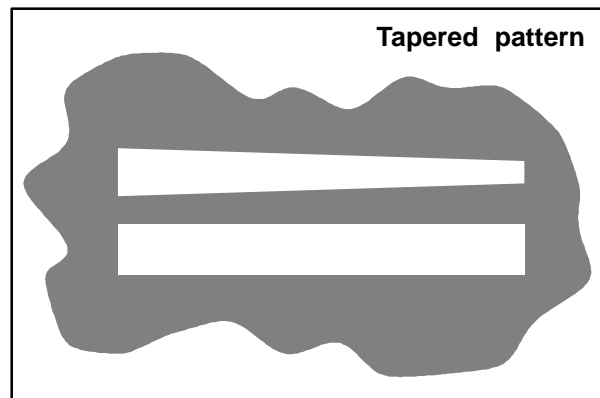

Uneven pattern

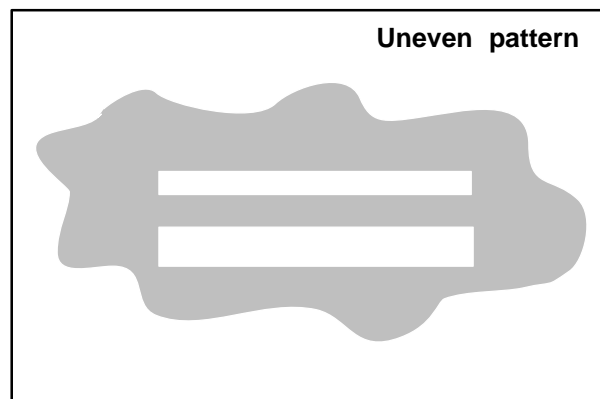

SCRUBBING

TO ADJUST TAPERED BRUSH PATTERN

1. Make sure the scrub head is in the raised position.

FOR SAFETY: Before Leaving Or Servicing Machine; Stop On Level Surface, Turn Off Machine.

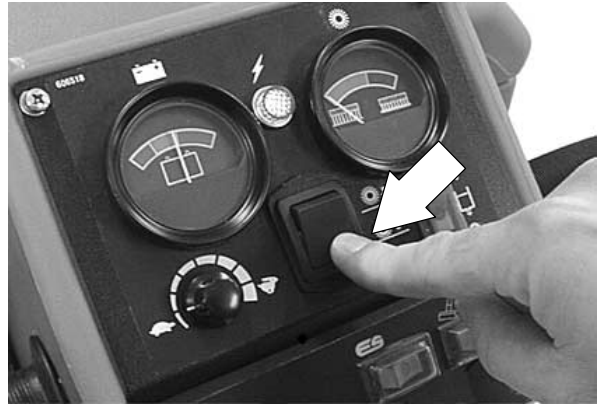

2. Turn the machine off.



3. Remove the brush idler plate from the end of the brush that has a taper. The brush idler plate is held in place with a spring clip. To remove the idler plate the spring clip must be pressed down flat to the top of the scrub head.

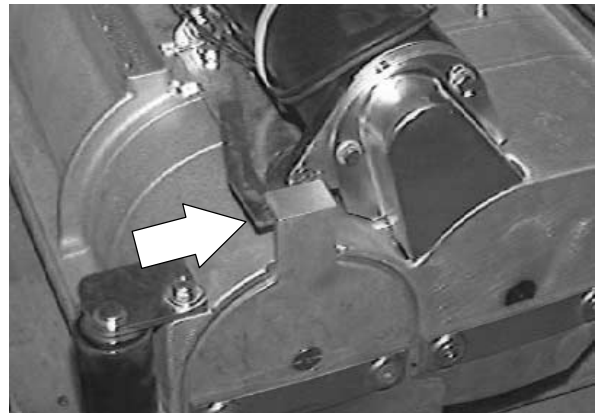

4. With the spring clip pressed down flat to the top of the scrub head, pull the bottom of the idler plate out of the end of the brush and off the spring clip.

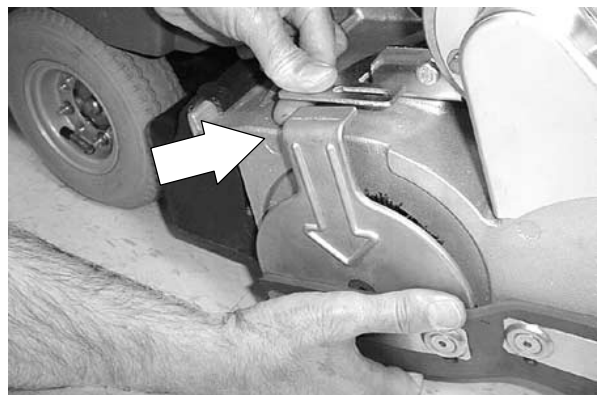

- Put a 3/8 inch open end wrench on the flat of the idler eccentric shaft, loosen the flat head screw with a 6mm. allen wrench.

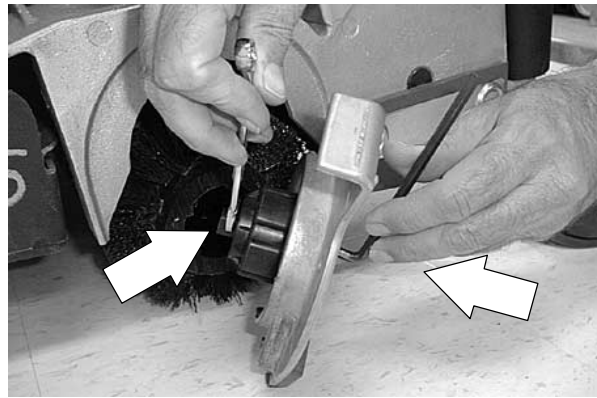

- Turn eccentric shaft to raise or lower that end of the brush. **Re-tighten** the flat head screw while holding the flat of eccentric shaft.

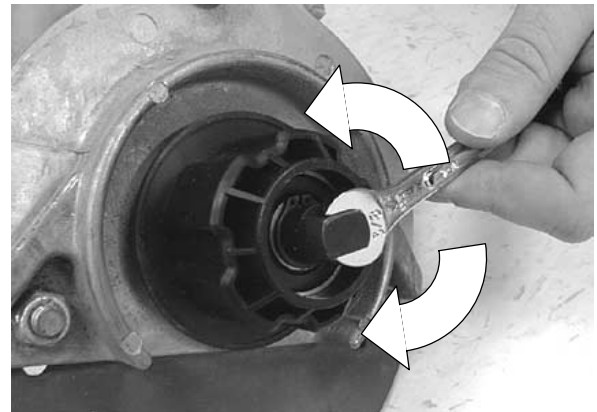

- Reinstall the idler plate and re-check the brush pattern. Re-adjust if necessary.



NOTE: Make sure to install the idler plate on the side it was removed from to avoid having to re-adjust the brush taper.

SCRUBBING

TO ADJUST UNEVEN BRUSH PATTERN

FOR SAFETY: Before Leaving Or Servicing Machine; Stop On Level Surface, Set Parking Brake, Turn Off Machine And Remove Key.

1. Lower the scrub head to the floor .
Apply maximum down pressure.

FOR SAFETY: Before Leaving Or Servicing Machine; Stop On Level Surface, Set Parking Brake, Turn Off Machine And Remove Key.



2. The scrub head levelness is checked by measuring from the edge of the scrub head to the floor at all four corners of the scrub head.

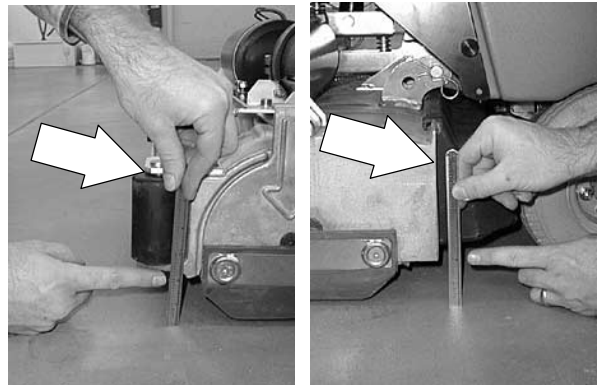

3. If the scrub head is not level, loosen the scrub head adjustment screw jam nut. Use a 1 inch open end wrench on the adjustment hex screw, located at the front of the pivot bracket, to adjust the angle of the scrub head. Make sure to re-tighten the jam nut. *Re-check the scrub head levelness.*

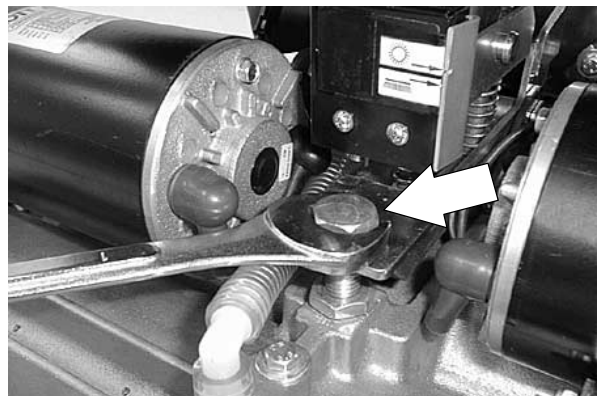

TO ADJUST CYLINDRICAL SCRUB HEAD SKIRTS

The cylindrical scrub head skirts should just touch the floor when the head is in the lowered position. Check the skirts for damage or wear daily.

1. Lower the scrub head on a level floor until the brushes make contact.



2. Turn the machine power off.

FOR SAFETY: Before Leaving Or Servicing Machine; Stop On Level Surface, Turn Off Machine.



3. Check to see if the scrub head skirts touch the floor on both sides of the scrub head.

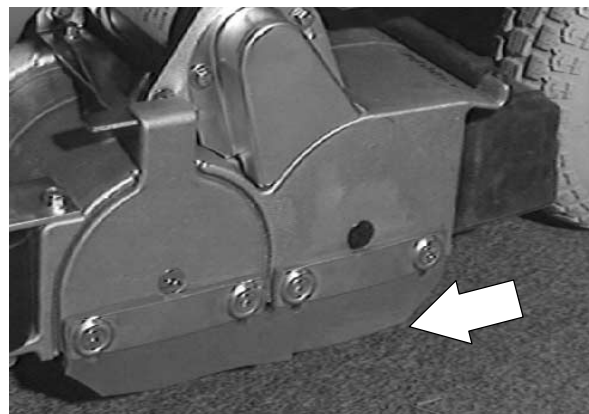

SCRUBBING

4. Loosen the four M8 flat head screws holding the skirt and retainer to the scrub head.

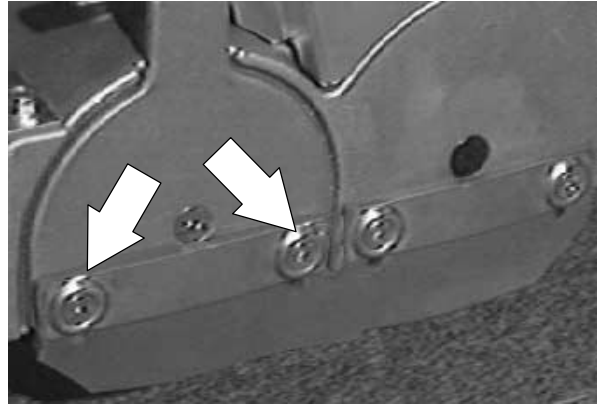

5. Adjust the skirt down so it lightly contacts the floor. Hand tighten the M8 flat head screws.

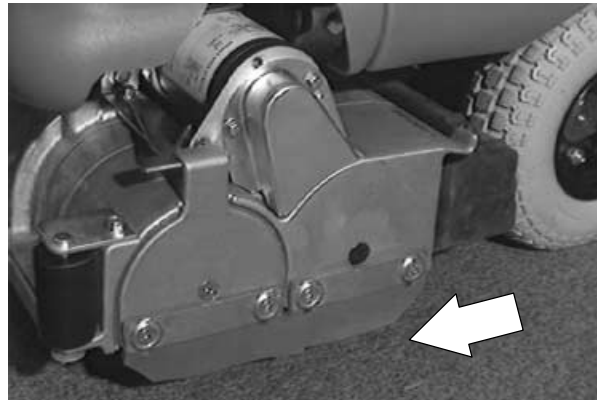

6. Operate the machine and check the scrub head skirts for proper operation.

TO REPLACE CYLINDRICAL SCRUB HEAD SKIRT

1. Make the scrub head is in the raised position.



2. Turn the machine power off.

FOR SAFETY: Before Leaving Or Servicing Machine; Stop On Level Surface, Turn Off Machine.



3. Remove the four M8 flat head screws holding the skirt retainer and skirt to the side of the scrub head. Remove the skirt.

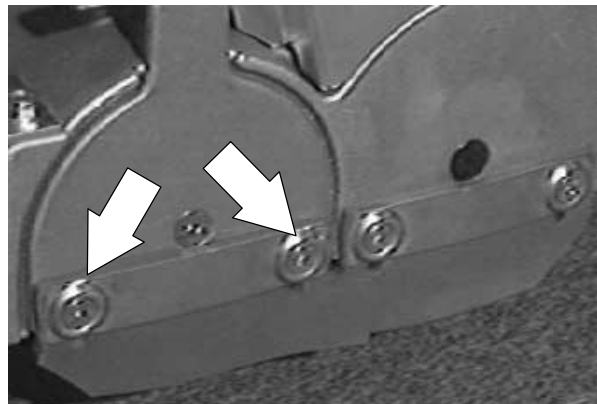

4. Position a new skirt under the skirt retainer and reinstall the four M8 flat head screws.

5. Adjust the skirt down so it lightly contacts the floor. Hand tighten the M8 flat head screws. *Do not over tighten.*

6. Operate the machine and check the scrub head skirts for proper operation.

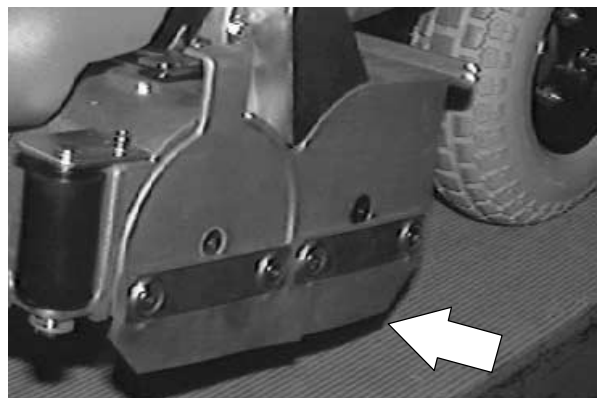

SCRUBBING

TO REPLACE CYLINDRICAL SCRUB BRUSH DRIVE BELT

FOR SAFETY: Before Leaving Or Servicing Machine; Stop On Level Surface, Set Parking Brake, Turn Off Machine And Remove Key.

1. Remove the scrub brush from the motor that the belt needs to be changed. See TO REPLACE A CYLINDRICAL SCRUB BRUSH instructions in this section.



2. Loosen the front and rear pivot bolts on the brush motor.

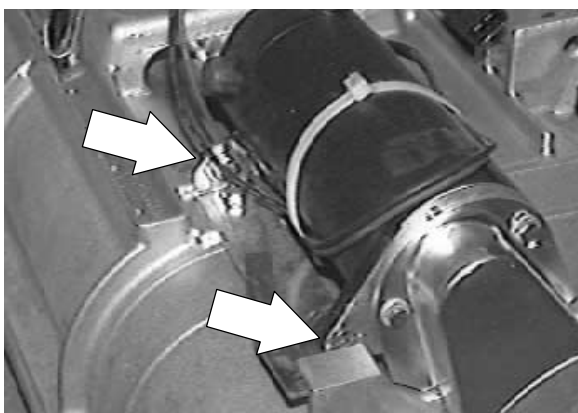

3. Remove the two M6 hex screws holding the belt guard onto the motor that the belt needs changing. *Remove the belt cover from the scrub head.*

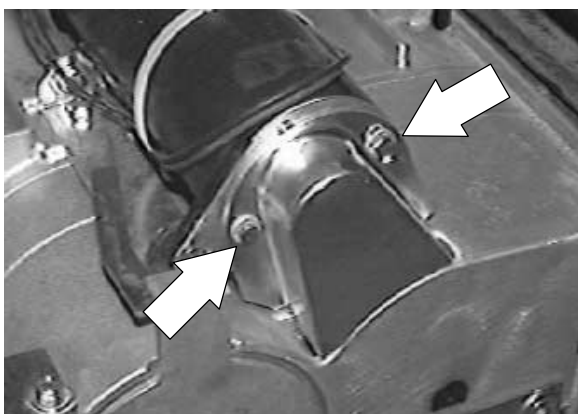

- Loosen the M8 hex nut on the belt tension bolt under the motor. Turn the tension bolt down far enough to allow the belt to be slipped off the motor pulley. Push the drive belt down toward the drive plug in the brush area.

NOTE: Make sure the scrub head is in the raised position before attempting to remove the drive plug rubber seal.

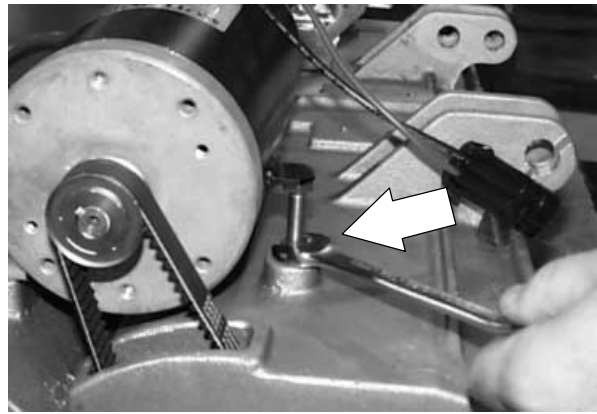

- Using a needle nose pliers, pull the rubber seal off the brush drive plug. Remove the belt cover from the bottom of the scrub head. *Take care not to damage the cover gasket.*

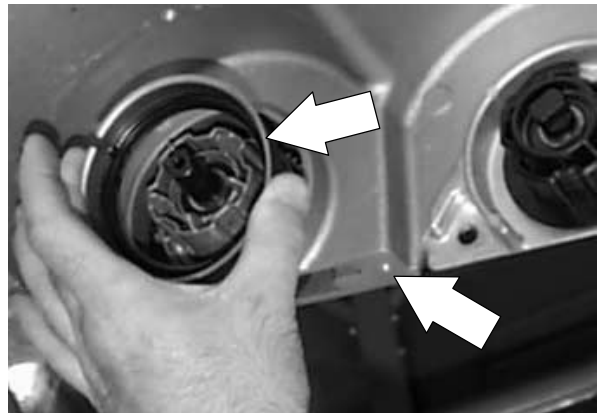

- Pull the drive belt off the bottom drive pulley.

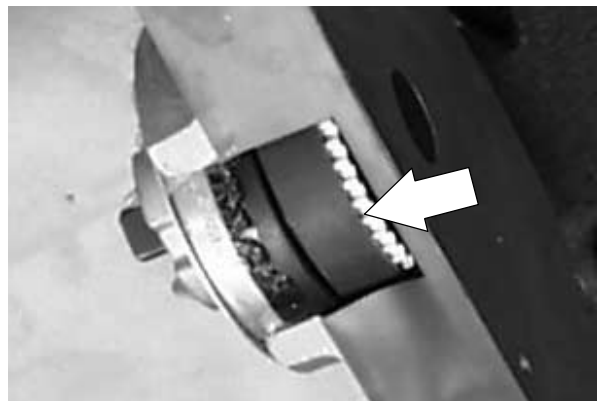

- Slip the new drive belt over the drive plug. Push the rest of the belt up to the drive motor and onto the motor drive pulley.

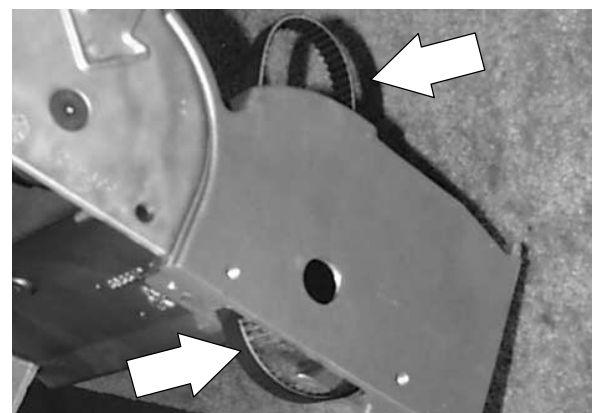

SCRUBBING

8. Install a new seal (part # 222820). Apply a bead of silicone sealant (part # 08317) around the seal to bond it in place. Reinstall the lower cover and gasket.

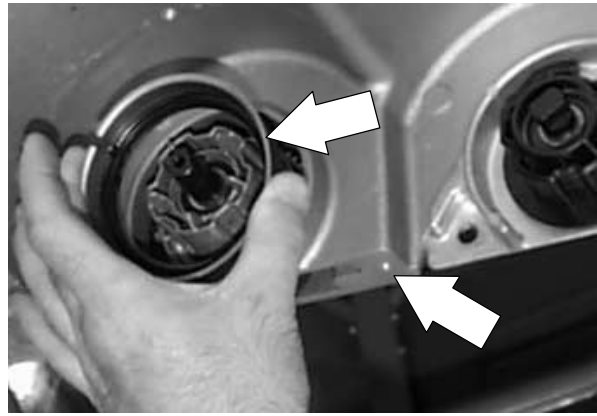

9. Using the M8 hex screw located under the brush motor, tension the belt by applying 2.5–2.7 lbs of force per belt at the middle of the span that is opposite the belt travel with a deflection of 0.10 inch.

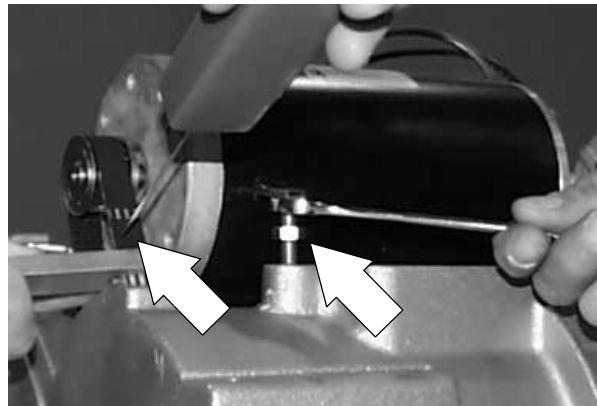

10. Tighten the two pivot bolts to 18 – 24 Nm (15 – 20 ft lb). Re-check the belt tension.

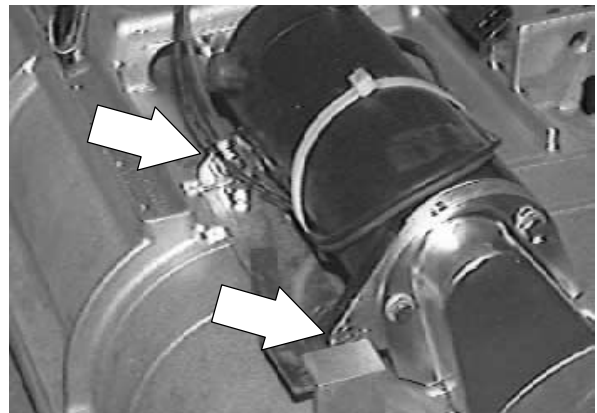

11. Reinstall the belt cover. Install the two M6 hex screws, and washers. Tighten to 11 – 14 Nm (7 – 10 ft lb).

12. Reinstall the scrub brush. See TO REPLACE A CYLINDRICAL SCRUB BRUSH instructions in this section.

13. Operate the machine and check for proper operation.

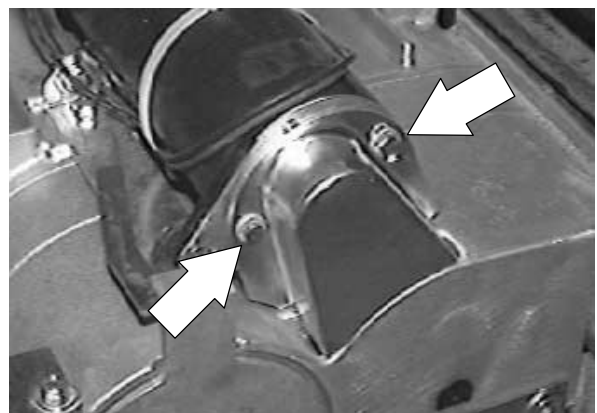

TO REPLACE CYLINDRICAL SCRUB BRUSH IDLER PLUG AND BEARING ASSEMBLY

FOR SAFETY: Before Leaving Or Servicing Machine; Stop On Level Surface, Set Parking Brake, Turn Off Machine And Remove Key.

1. Remove the scrub brush idler door. See TO REPLACE A CYLINDRICAL SCRUB BRUSH instructions in this section.

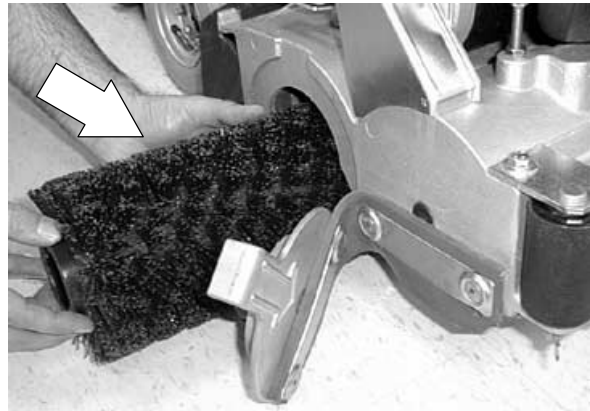

2. Remove the M10 flat screw holding the idler plug to the brush door.

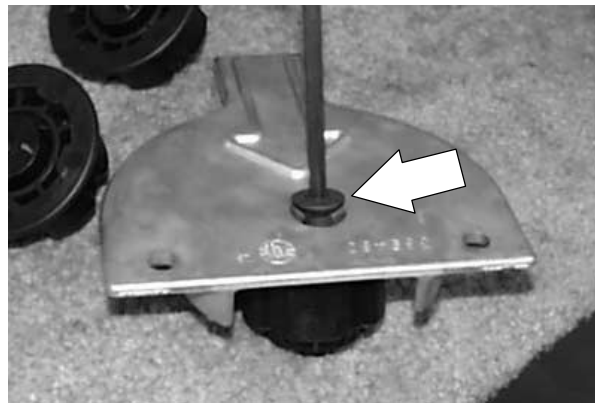

3. Remove the snap ring holding the plastic idler plug and bearing assembly to the idler plug shaft.

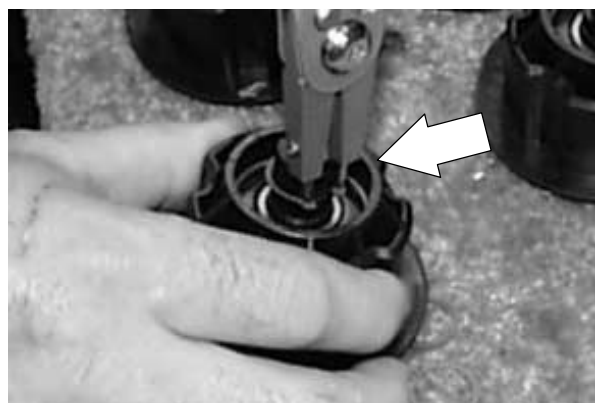

SCRUBBING

4. Use an arbor press to remove the brush plug and bearing assembly from the brush plug shaft. Use the arbor press to install a new bearing drive plug assembly onto the existing idler shaft.

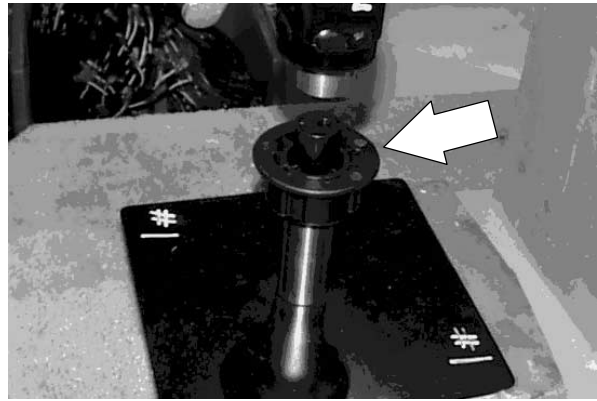

5. Reinstall the snap ring onto the idler shaft.



6. Reinstall the M10 flat screw holding the idler plug shaft and hub assembly to the brush door. Make sure to align the small pin on the shaft base with the hole in the brush door. *Leave the flat screw loose for now, the brush hub will need to be adjusted later.*

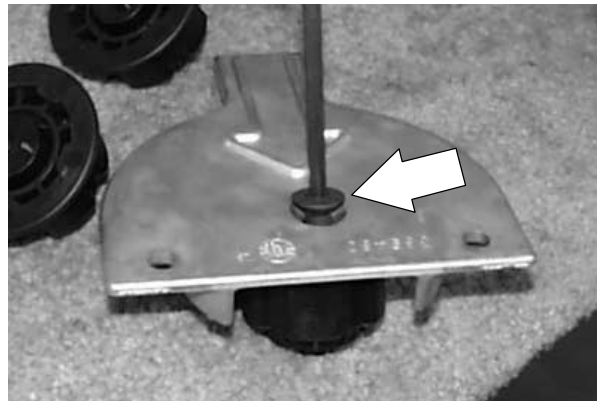

7. Reinstall the cylindrical scrub brush idler door. See TO REPLACE A CYLINDRICAL SCRUB BRUSH instructions in this section.

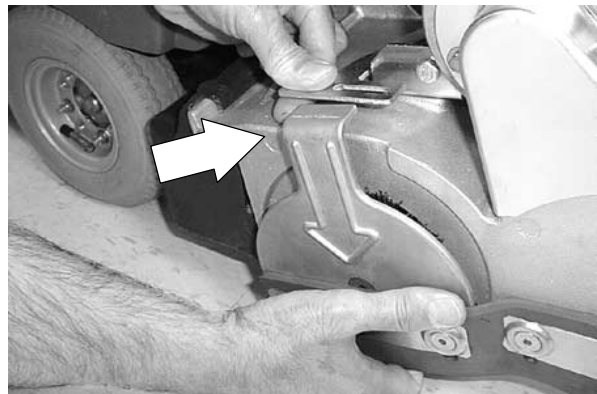

8. Operate the machine. Check the cylindrical scrub brush pattern. See TO CHECK CYLINDRICAL BRUSH PATTERN instructions in this section.

**TO REPLACE CYLINDRICAL SCRUB BRUSH
DRIVE PLUG BEARINGS**

**FOR SAFETY: Before Leaving Or Servicing
Machine; Stop On Level Surface, Set Parking
Brake, Turn Off Machine And Remove Key.**

1. Remove the scrub brush. See TO REPLACE A CYLINDRICAL SCRUB BRUSH instructions in this section.

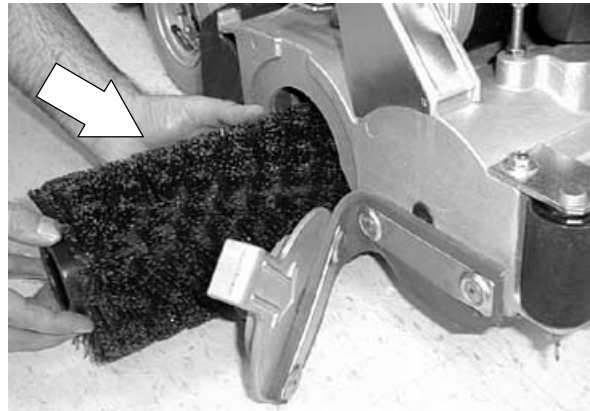

2. Loosen the front and rear pivot bolts on the brush motor.

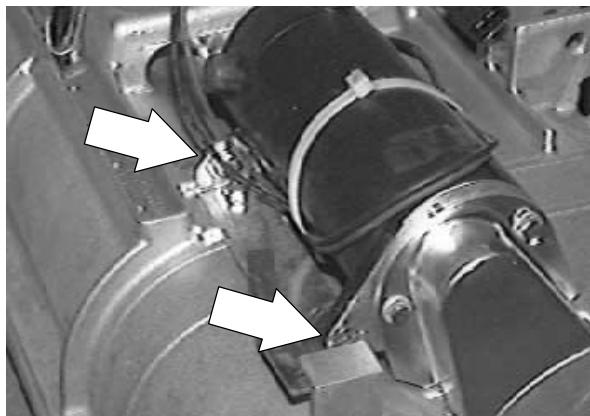

3. Remove the two M6 hex screws holding the belt guard and belt shield on the motor that the belt needs changing. *Remove the belt cover from the scrub head.*

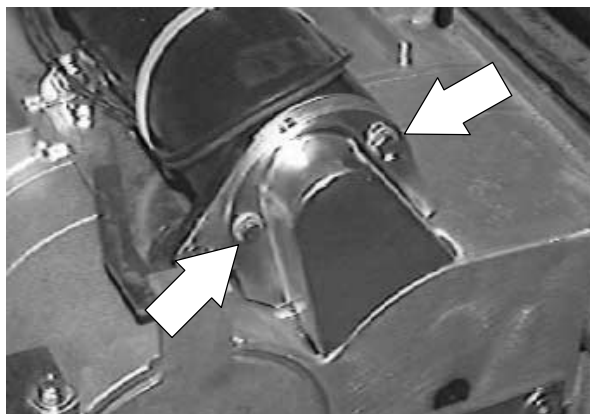

SCRUBBING

4. Loosen the M8 hex nut on the belt tension bolt under the motor. Turn the tension bolt down far enough to allow the belt to be slipped off the motor pulley. Push the drive belt down toward the drive plug in the brush area.

NOTE: Make sure the scrub head is in the raised position before attempting to remove the drive plug rubber seal.

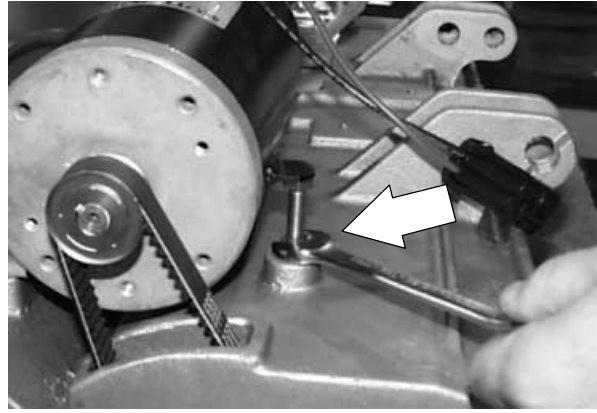

5. Using a needle nose pliers, pull the rubber seal off the brush drive plug. Remove the belt cover from the bottom of the scrub head. *Take care not to damage the cover gasket.*

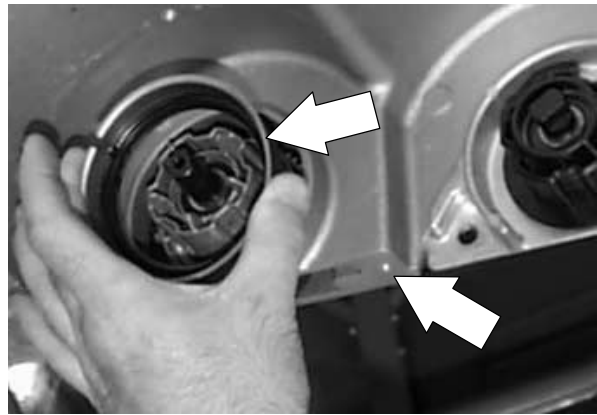

6. Pull the drive belt off the bottom drive pulley.

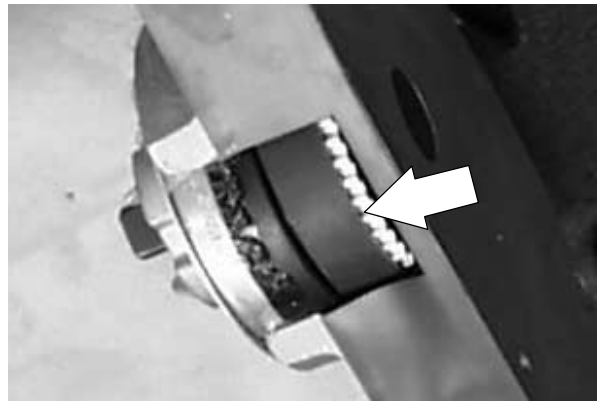

7. Unscrew the drive plug assembly from the scrub head casting.

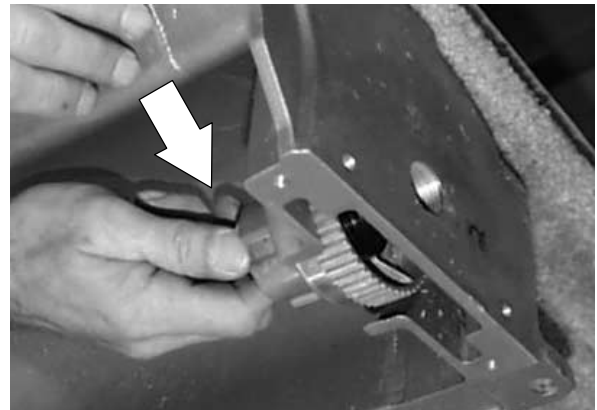

- Remove the snap ring holding the hub and bearing to the hub shaft.

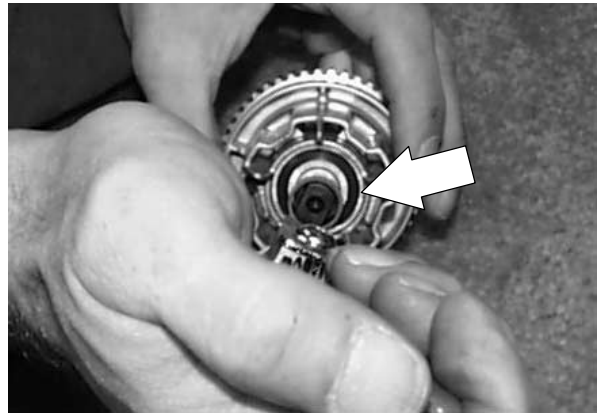

- Use an arbor press to remove the two bearings from the brush drive plug.

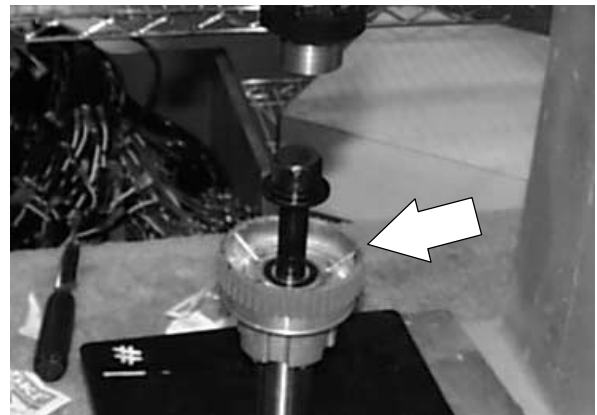

- Use the arbor press to first—press the inner bearing onto the hub shaft.



- Secondly—press the drive hub onto the inner bearing.

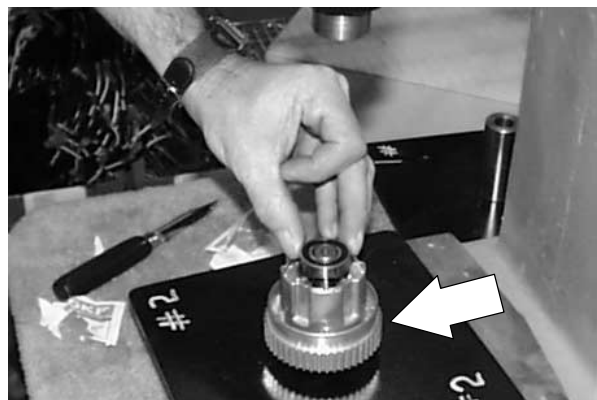

SCRUBBING

13. Thirdly—press the outer bearing into the drive hub.

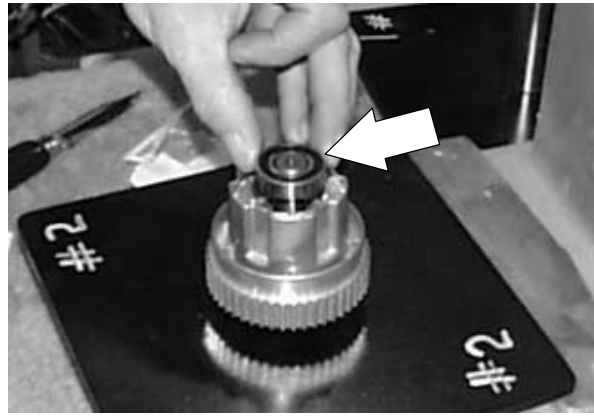

14. Reinstall the snap ring onto the hub shaft.

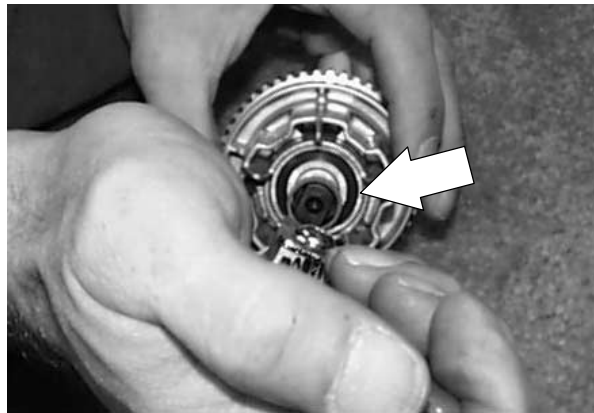

15. Place a small amount of Loctite blue 242 on the threads of the drive hub shaft.

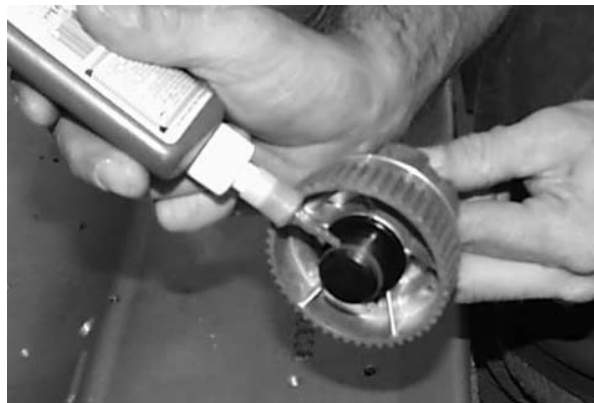

16. Reinstall the drive hub shaft onto the scrub head casting. Tighten firmly.

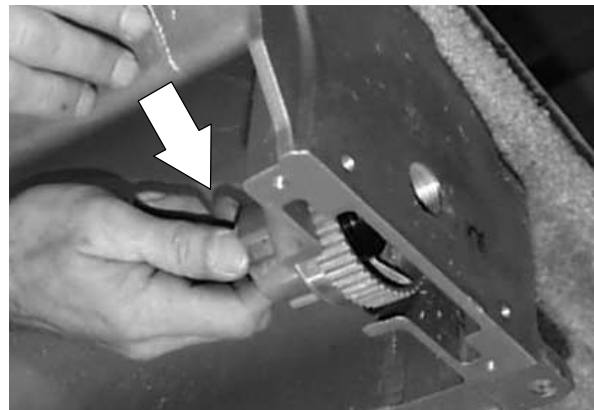

8. Slip the new drive belt over the drive plug. Push the rest of the belt up to the drive motor and onto the motor drive pulley.

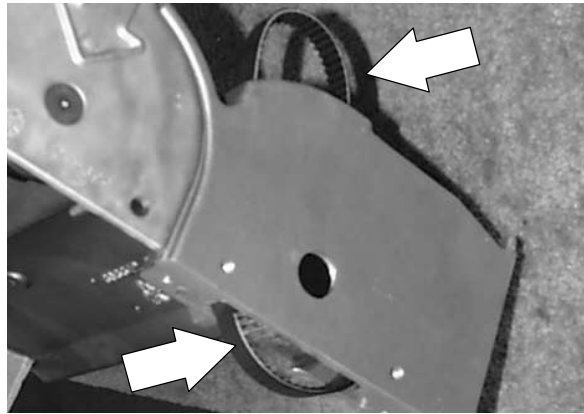

9. Install a new seal (part # 222820). Apply a bead of silicone sealant (part # 08317) around the seal to bond it in place. Reinstall the lower cover and gasket.

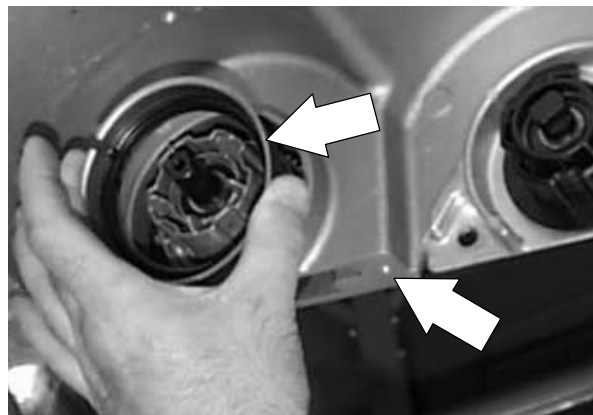

10. Using the M8 hex screw located under the brush motor, tension the belt by applying 2.5–2.7 lbs of force per belt at the middle of the span that is opposite the belt travel with a deflection of 0.10 inch.

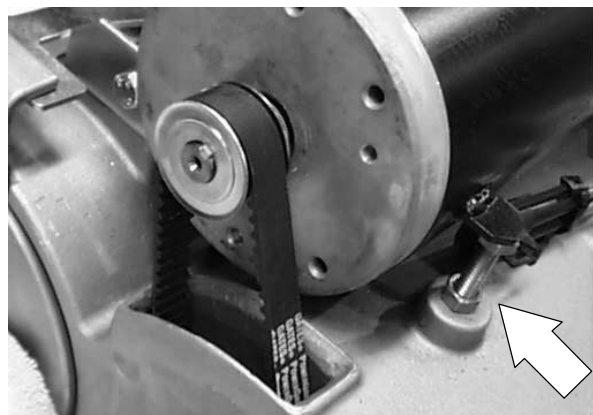

11. Tighten the two pivot bolts to 18 – 24 Nm (15 – 20 ft lb). Re-check the belt tension.

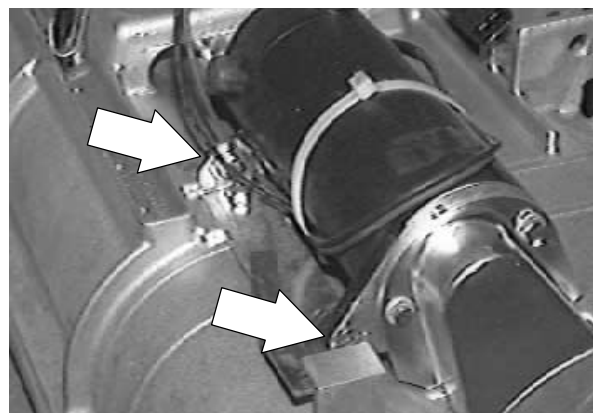

SCRUBBING

12. Reinstall the belt cover, two M6 hex screws, and washers. Tighten to 11 – 14 Nm (7 – 10 ft lb).

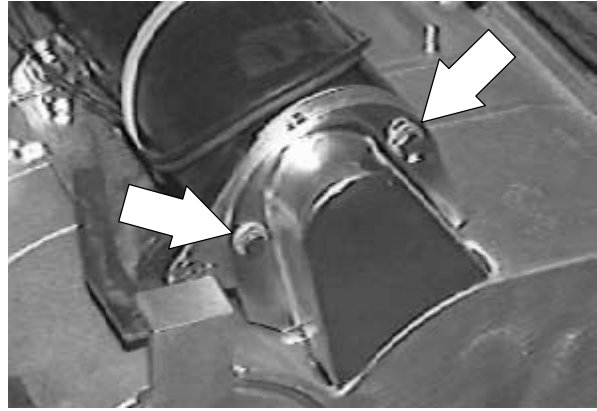

13. Reinstall the scrub brush. See TO REPLACE A CYLINDRICAL SCRUB BRUSH instructions in this section.



14. Operate the machine and check for proper operation.

SQUEEGEE

The squeegee channels water into the vacuum fan suction. The front blade channels the water, and the rear blade wipes the floor.

Check the squeegee blades for damage and wear daily. Rotate or replace either of the squeegee blades if the leading edge is torn or worn half-way through the thickness of the blade.

The squeegee can be removed from the squeegee pivot so the squeegee will not be damaged during transport of the machine.

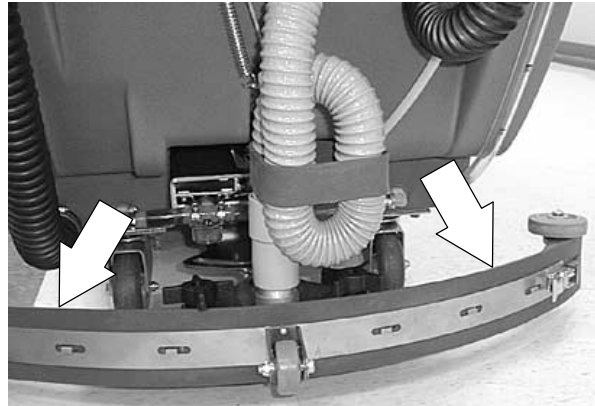

TO REMOVE SQUEEGEE

FOR SAFETY: Before Leaving Or Servicing Machine; Stop On Level Surface, Turn Off Machine.

1. Raise the squeegee.



2. Remove the squeegee suction hose from the squeegee.



SCRUBBING

3. Loosen the two mounting thumbscrews.

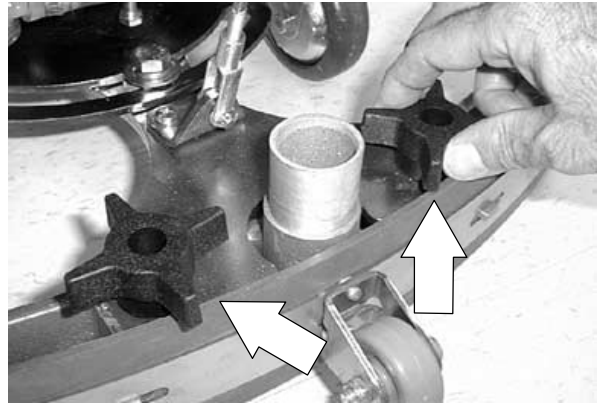

4. Pull the squeegee off the machine.

NOTE: Reverse this order to install the squeegee assembly.

5. Operate the machine. Check the squeegee for proper operation.



TO REPLACE OR ROTATE REAR SQUEEGEE BLADE

FOR SAFETY: Before Leaving Or Servicing Machine; Stop On Level Surface, Turn Off Machine.

1. Raise the squeegee.

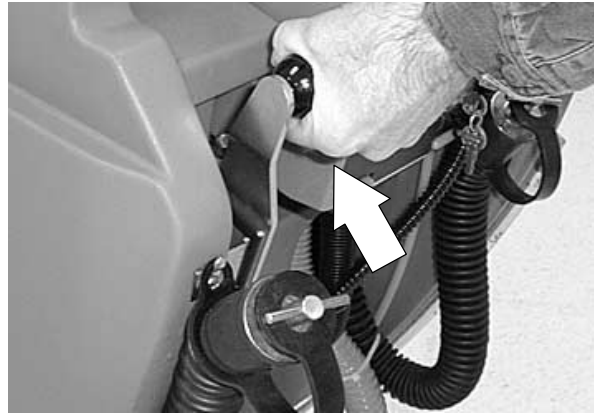

2. Un-snap the squeegee rear retainer clamp.

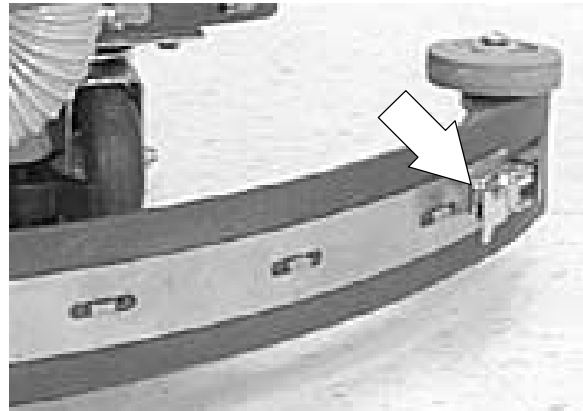

3. Remove the retainer and squeegee blade from the squeegee frame.

NOTE: Reverse this order to install the squeegee blade and retainer.

4. Operate the machine. Check the squeegee for proper operation.

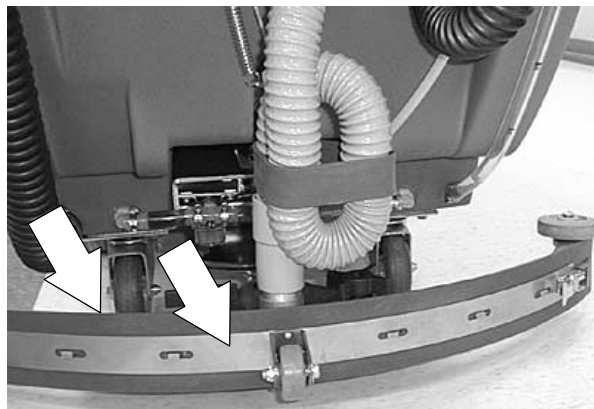

SCRUBBING

TO REPLACE OR ROTATE FRONT SQUEEGEE BLADE

FOR SAFETY: Before Leaving Or Servicing Machine; Stop On Level Surface, Turn Off Machine.

1. Raise the squeegee.

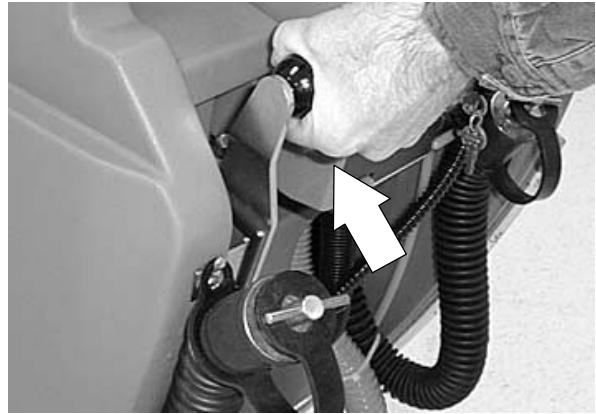

2. Remove the six thumbscrews holding the retainer and squeegee blade to the squeegee frame.

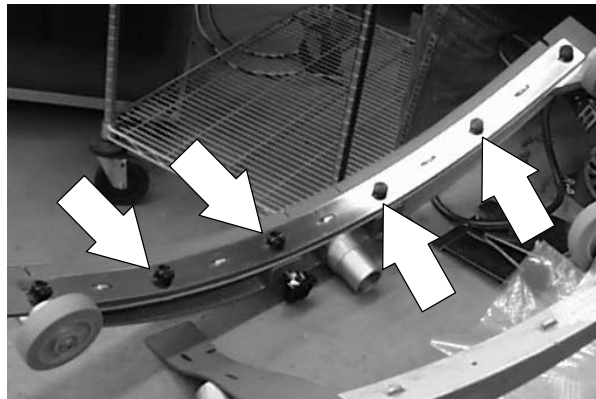

3. Pull the squeegee blade off the squeegee frame.

NOTE: Reverse this order to install the squeegee blade and retainer.

4. Operate the machine. Check the squeegee for proper operation.

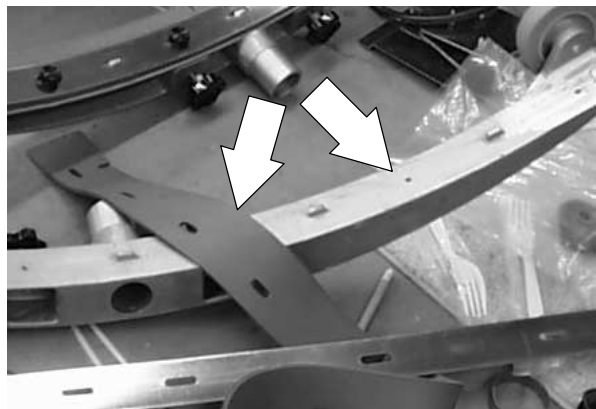

TO REPLACE SQUEEGEE LIFT CABLE

FOR SAFETY: Before Leaving Or Servicing Machine; Stop On Level Surface, Turn Off Machine.

1. Lower the squeegee.



2. Disconnect the tension spring from the squeegee lift cable.

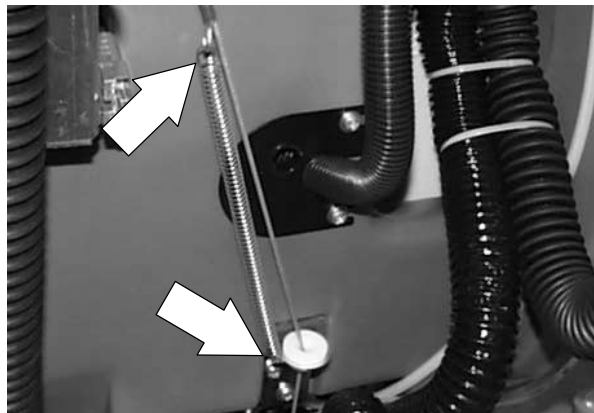

3. Remove the cotter pin and clevis pin from the end of the lift cable where it attaches to the lower bracket.



SCRUBBING

4. Remove the clevis from the bottom end of the cable.

Note the amount of threads the clevis is turned onto the existing lift cable. Install the clevis onto the new cable in the same location.

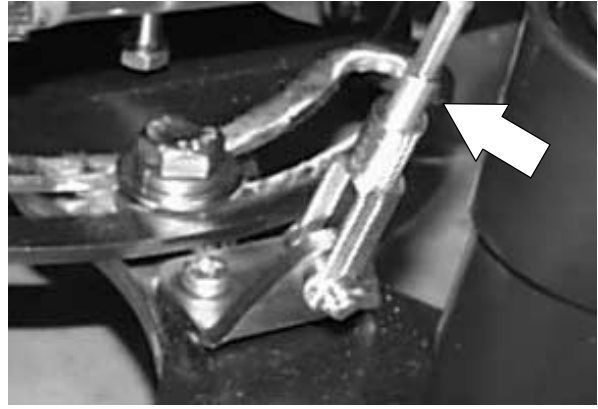

5. Loosen the jam nut holding the squeegee lift cable to the ball joint. Un-screw the cable from the ball joint.



6. Pull the cable end through the cable bushing. Remove the cable from the machine.

Remove the balljoint end and jam nut from the existing cable. Install the jam nut and balljoint in the same location on the new lift cable.

NOTE: Reverse this order to install the squeegee lift cable.

7. Operate the machine. Check the squeegee lift cable for proper operation.

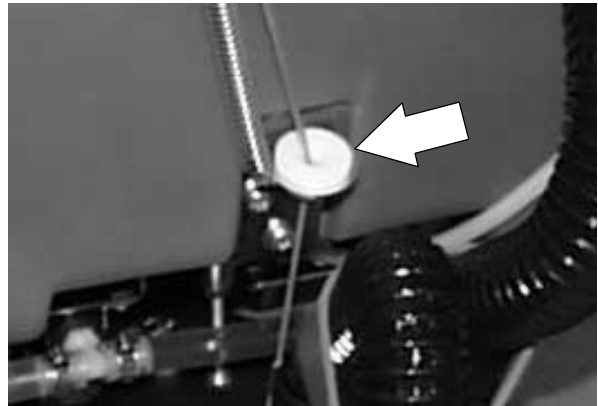

TO REPLACE SOLUTION FLOW CONTROL CABLE

FOR SAFETY: Before Leaving Or Servicing Machine; Stop On Level Surface, Turn Off Machine.

1. Use a 5/64 inch allen wrench to loosen the set screw holding the solution flow control cable to the end of the valve. *Pull the cable off the valve.*

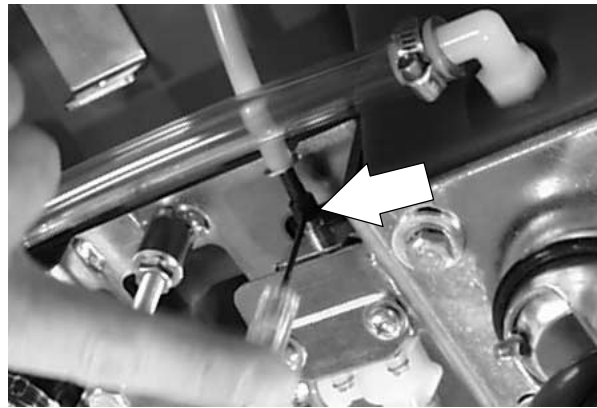

2. Remove the four pan screws holding the solution flow bracket assembly to the back of the solution tank.

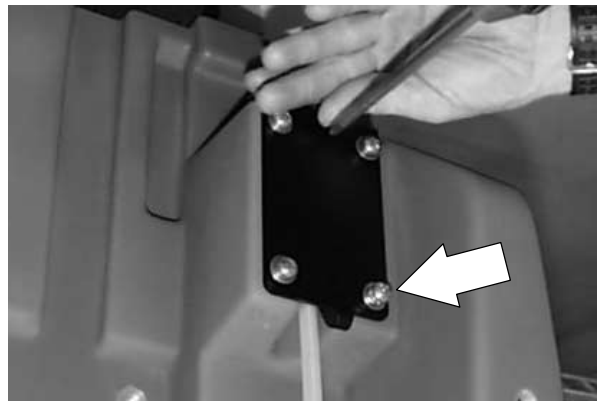

3. Use a small, flat screw driver to remove the solution control knob from the top of the cable.

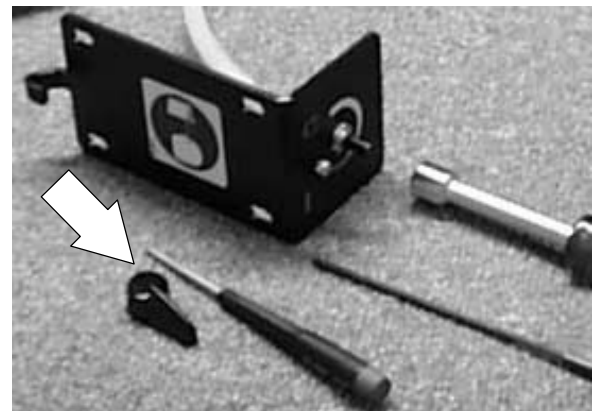

SCRUBBING

4. Use a 1/2 inch nut driver to remove the cable jam nut. *Remove the solution cable from the bracket.*

NOTE: Reverse this order to install the new solution control cable.

5. Operate the machine. Check the new solution cable for proper operation.

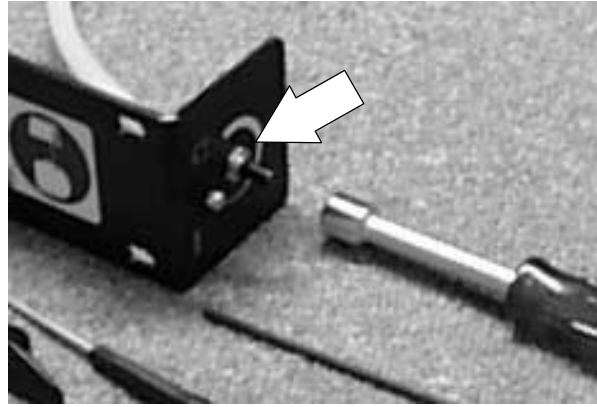

MACHINE TROUBLESHOOTING

Problem	Cause	Remedy	
Trailing water – poor or no water pickup	Worn squeegee blades	Rotate or replace squeegee blades	
	Vacuum hose clogged	Flush vacuum hoses	
	Recovery tank full	Drain recovery tank	
	Vacuum fan will not turn on		Drain recovery tank
			Reset vacuum fan circuit breaker
	Debris caught on squeegee	Remove debris	
	Foam filling recovery tank	Empty recovery tank; use less or change detergent	
	Vacuum hose to squeegee or recovery tank disconnected or damaged	Reconnect or replace vacuum hose	
	Recovery tank float screen clogged	Clean screen	
Recovery tank cover not closed completely	Close cover		
Little or no solution flow to the floor	Solution tank empty	Fill solution tank	
	Solution switch off	Turn switch on	
	Solution control cable broken or out of adjustment	Replace and/or adjust cable	
	Solution flow knob turn off	Turn solution flow knob on	
	Solution supply lines plugged	Flush solution supply lines	
	Solution solenoid clogged or stuck	Clean or replace	
	ES™ mode: ES™ switch off	Turn ES™ switch on	
Poor scrubbing performance	Debris caught on scrub brushes	Remove debris	
	Improper detergent, brush, or pad used	Check with TENNANT representative for advice	
	Worn scrub brush or pad	Replace scrub brush or pad	
	Scrub brush motor circuit breaker tripped		Reset circuit breaker
			Adjust scrub brush down pressure, check with TENNANT representative for advice
	Low battery charge	Charge batteries	
	Low scrub brush down pressure	Adjust scrub brush down pressure, check with TENNANT representative for advice	

CONTENTS

	Page		Page
ELECTRICAL SYSTEM	4-3	ELECTRIC MOTORS	4-55
BATTERIES	4-4	TO REPLACE VACUUM FAN	
TO CHARGE BATTERIES	4-6	MOTOR BRUSHES	4-55
TO REPLACE CHARGER SAFETY		TO REPLACE DISC SCRUB BRUSH	
SWITCH	4-8	MOTOR BRUSHES	4-57
INSTRUMENT PANEL	4-11	ELECTRICAL SCHEMATIC	4-59
TO ACCESS INSTRUMENT PANEL .	4-11	WIRING DIAGRAM	4-60
TO REMOVE HANDLE BAR GEAR		WIRING DIAGRAM (OPTIONS)	4-61
HUB	4-13	TROUBLESHOOTING	4-63
TO REPLACE POTENTIOMETER		POWER UP CIRCUIT	4-64
SWITCH	4-15	NO POWER (KEY ON AND BATTERY	
TO ADJUST POTENTIOMETER	4-17	CHARGER DISCONNECTED) ...	4-65
TO REPLACE SPEED CONTROL		PROPEL CIRCUIT	4-68
BOARD	4-18	NO PROPEL (POWER UP O.K.) .	4-69
TO REPLACE 24 VOLT		NO PROPEL – CONTROL BOARD	
CONTACTOR	4-20	TROUBLESHOOTING	4-71
TO REPLACE RESETTABLE		BRUSH CIRCUIT	4-72
CIRCUIT BREAKER	4-21	BOTH BRUSHES DO NOT OPERATE	
TO REPLACE 24 VOLT SOLENOID .	4-22	WITH BRUSH DECK DOWN	4-73
VACUUM FAN	4-25	BRUSH MOTOR 1 DOES NOT	
TO REPLACE VACUUM FAN	4-25	OPERATE	4-75
TO REPLACE VACUUM FAN		BRUSH MOTOR 2 DOES NOT	
SWITCH	4-28	OPERATE	4-76
SCRUB BRUSH MOTORS	4-31	ACTUATOR CIRCUIT	4-78
TO REPLACE DISC SCRUB		BRUSH DECK WILL NOT LOWER	4-79
BRUSH MOTOR	4-31	BRUSH DECK WILL NOT RAISE .	4-80
TO REPLACE CYLINDRICAL HEAD		VACUUM FAN CIRCUIT	4-82
SCRUB BRUSH MOTOR	4-36	VACUUM FAN DOES	
ACTUATOR	4-42	NOT OPERATE	4-83
TO REPLACE SCRUB HEAD		SOLUTION SOLENOID CIRCUIT ...	4-86
LIFT ACTUATOR	4-42	SOLUTION SOLENOID DOES NOT	
SOLUTION SOLENOID VALVE	4-47	OPERATE (BRUSHES WORK) ...	4-87
TO REPLACE SOLUTION SOLENOID		ES™ SOLENOID CIRCUIT	4-88
VALVE	4-47	ES™ PUMP DOES NOT OPERATE	4-89
OPTIONAL EXTENDED SCRUB	4-51	WAND PUMP CIRCUIT	4-92
TO REPLACE THE ES™ PUMP	4-51	WAND PUMP DOES	
OPTIONAL POWER WAND	4-53	NOT OPERATE	4-93
TO REPLACE POWER WAND			
PUMP	4-53		

ELECTRICAL SYSTEM

The 5400 electrical system consists of the batteries, electrical drive motor, scrub brush motors, vacuum fan motor, power control panel and related components. This section includes information on these components and their troubleshooting.

BATTERIES

The batteries are unique in that they hold their power for long periods of time. The lifetime of the batteries is limited by the number of charges the batteries receive. To get the most life from the batteries, charge them when the battery discharge indicator needle remains in the **red** zone of the indicator.

Periodically clean the top surface of the batteries and the terminals, and check for loose connections. Use a strong solution of baking soda and water. Brush the solution sparingly over the battery tops, terminals, and cable clamps. Do not allow any baking soda solution to enter the batteries. Use a wire brush to clean the terminal posts and the cable connectors. After cleaning, apply a coating of clear battery post protectant to the terminals and the cable connectors. Keep the tops of the batteries clean and dry.

Keep all metallic objects off the top of the batteries, which may cause a short circuit. Replace any worn or damaged wires.

Never add acid to the batteries, only distilled water. Always keep the battery caps on, except when adding water or taking hydrometer readings.



Measuring the specific gravity using a hydrometer is a way to determine the charge level, and condition of the batteries. If one or more of the battery cells test lower than the other battery cells (0.050 or more), the cell is damaged, shorted, or is about to fail.

NOTE: Do not take readings immediately after adding distilled water. If the water and acid are not thoroughly mixed, the readings may not be accurate. Check the hydrometer readings against the following chart to determine the remaining battery charge level:

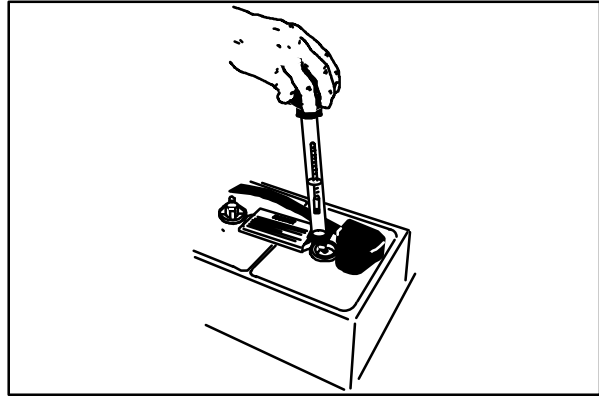

SPECIFIC GRAVITY at 27° C (80° F)	BATTERY CHARGE
1.265	100% Charged
1.223	75% Charged
1.185	50% Charged
1.148	25% Charged
1.110	Discharged

NOTE: If the readings are taken when the battery electrolyte is any temperature other than 27° C (80° F), the reading must be temperature corrected. Add or subtract to the specific gravity reading 0.004, 4 points, for each 6° C (10° F) above or below 27° C (80° F).

ELECTRICAL

TO CHARGE BATTERIES

1. Drive the machine to a flat, dry surface in a well-ventilated area.
2. Turn the machine power off and set the parking brake if your machine has this option.

FOR SAFETY: Before Leaving Or Servicing Machine; Stop On Level Surface, Turn Off Machine.



3. Raise the recovery tank for access to the batteries.

NOTE: The recovery tank must be empty.

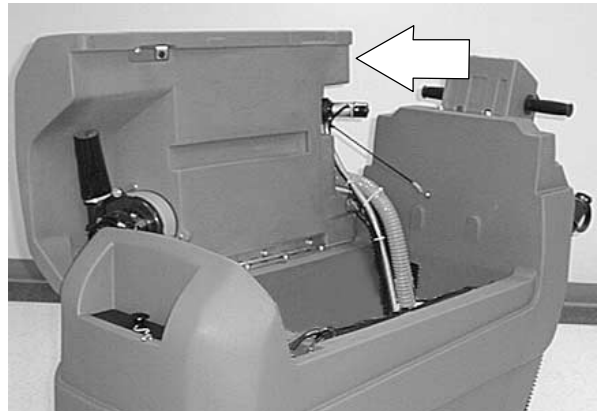

4. Check fluid level (A) in each battery cell before charging. If battery plates (B) are exposed, add just enough distilled water to cover plates by approximately 3 mm (0.13 in). DO NOT OVERFILL. Overfilled batteries can overflow during charging due to fluid expansion. Replace cell caps before charging.

NOTE: Make sure the battery caps are in place while charging.

FOR SAFETY: When Maintaining or Servicing Machine, Avoid Contact With Battery Acid.

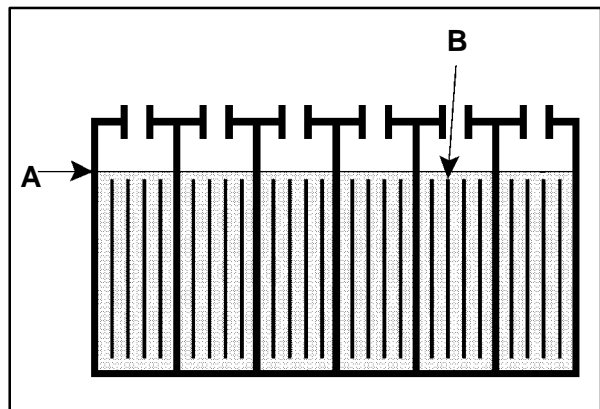

5. Plug the charger connector into the battery connector.

⚠ WARNING: Batteries Emit Hydrogen Gas. Explosion Or Fire Can Result. Keep Sparks And Open Flame Away. Keep Covers Open When Charging.



6. Plug the battery charger into the wall outlet.

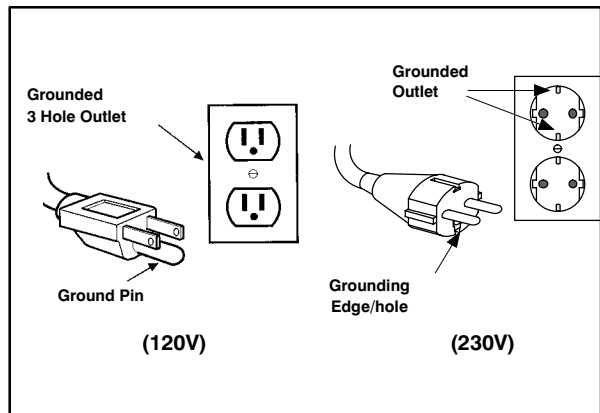

7. The charger will start automatically. When the batteries are fully charged, the charger will automatically turn off.
8. After the charger has turned off, unplug the charger from the wall outlet.
9. Unplug the charger connector from the battery connector on the machine.

FOR SAFETY: When Maintaining or Servicing Machine, Avoid Contact With Battery Acid.

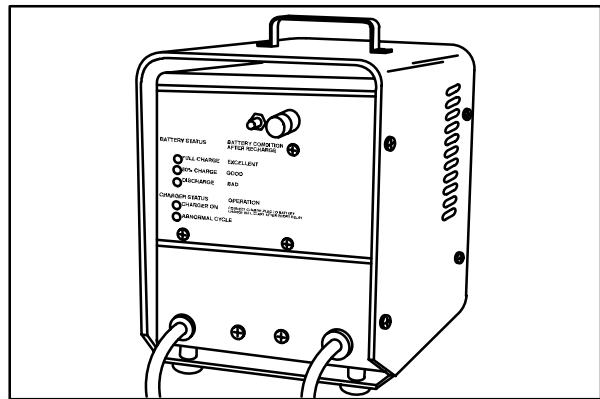

07224

10. Check the electrolyte level in each battery cell. Add just enough distilled water to bring the electrolyte level up to the fill rings.
11. Lower the recovery tank.
12. Rotate the stop arm out of the way to allow the recovery tank to close completely.

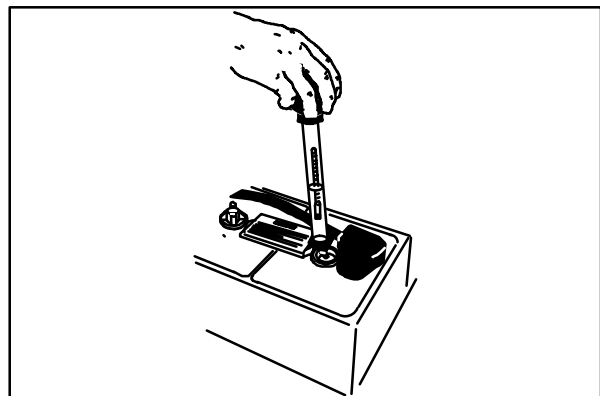

ELECTRICAL

TO REPLACE CHARGER SAFETY SWITCH

FOR SAFETY: Before Leaving Or Servicing Machine; Stop On Level Surface, Set Parking Brake, Turn Off Machine And Remove Key.

NOTE: Drain the recovery tank.

1. Open the recovery tank.

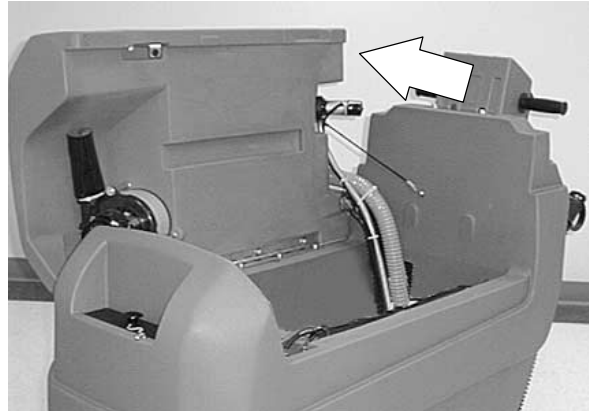

2. Disconnect the positive battery cable from the front, left machine battery.

FOR SAFETY: Disconnect the battery connections before working on the machine.

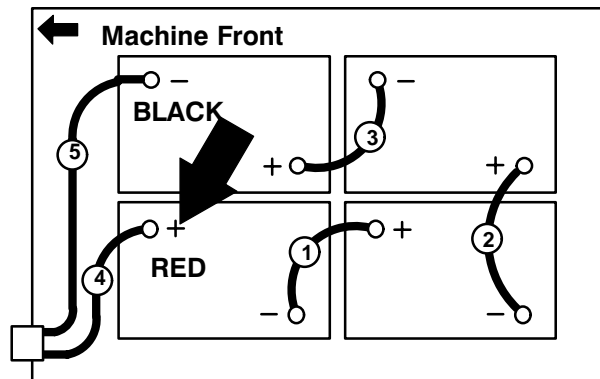

3. Lower the squeegee.



4. Remove the three hex screws holding the squeegee lever bracket assembly to the left side of the solution tank.

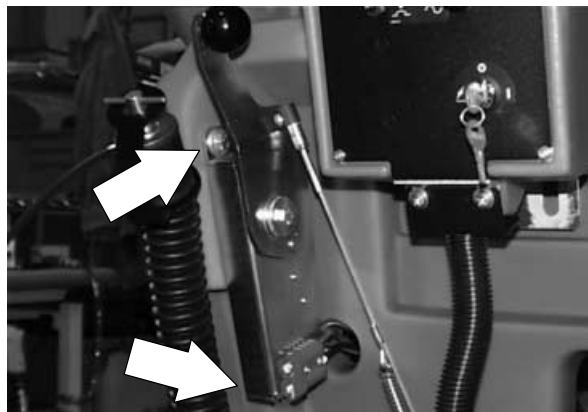

5. Locate the charger safety switch at the bottom of the lever bracket assembly. Mark and disconnect the wires leading to the switch.

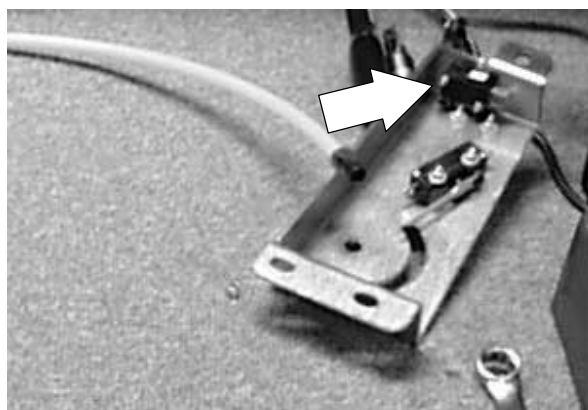

6. Remove the two hex screws and nuts holding the charger safety switch to the bracket. Remove the switch.

7. Install the new switch onto the bracket. Reinstall the hex screws and nuts. *Position the switch so it is activated when the connector from the battery charger is plugged into the machine connector.* Tighten the hardware.

8. Reconnect the wires to the new switch. See electrical schematic in this section.

9. Position the squeegee lever bracket assembly to the left side of the solution tank. Reinstall the three hex screws and tighten to 18 – 20 Nm (15 – 18 ft lb).

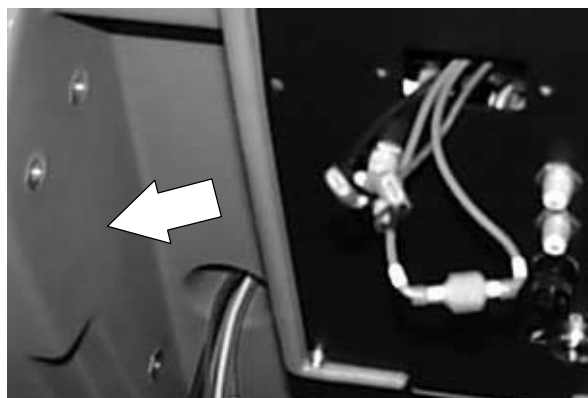

ELECTRICAL

10. Raise the squeegee.

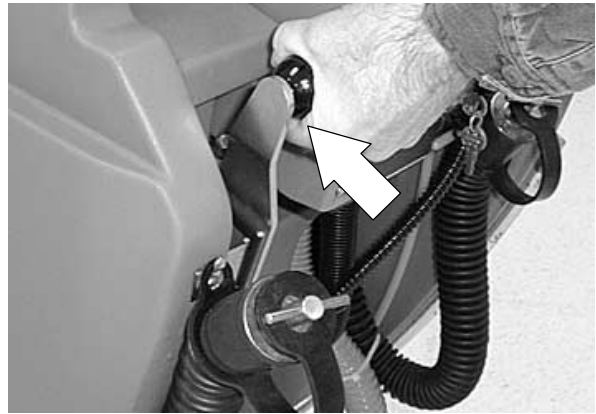

11. Reconnect the positive battery cable to the battery.

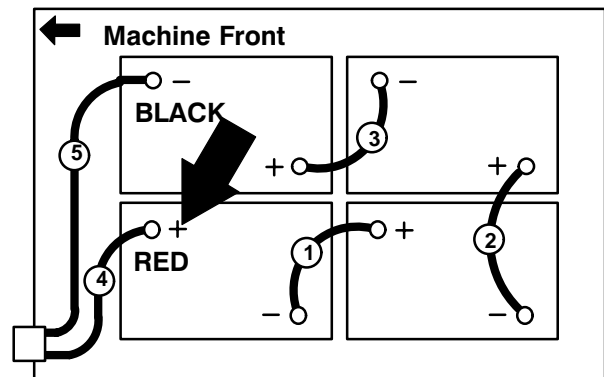

12. Operate the machine. Check the charger safety switch for proper operation. The machine **MUST NOT** turn on with the key when the charger is plugged into the machine connector. *If the machine starts with the charger plugged in, readjust the safety switch.*



INSTRUMENT PANEL

The instrument panel contains the electrical controls needed to operate the machine. The battery meter, brush pressure gauge, rocker switches, relays, contactor, and fuses are located on the panel. By removing the attachment hardware, the panel can be pulled back to access these components.

TO ACCESS INSTRUMENT PANEL

FOR SAFETY: Before Leaving Or Servicing Machine; Stop On Level Surface, Turn Off Machine.

1. Open the recovery tank.

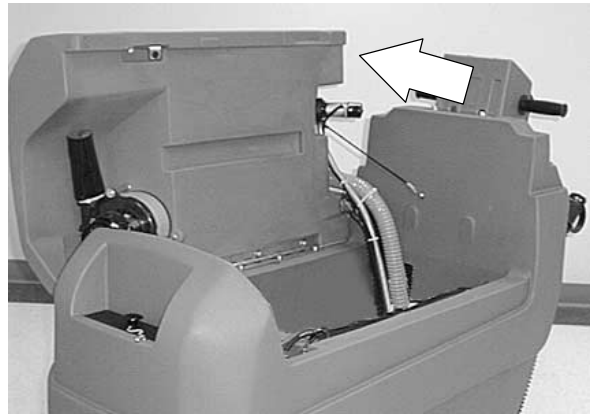

2. Disconnect the positive battery cable from the front, left machine battery.

FOR SAFETY: Disconnect the battery connections before working on the machine.

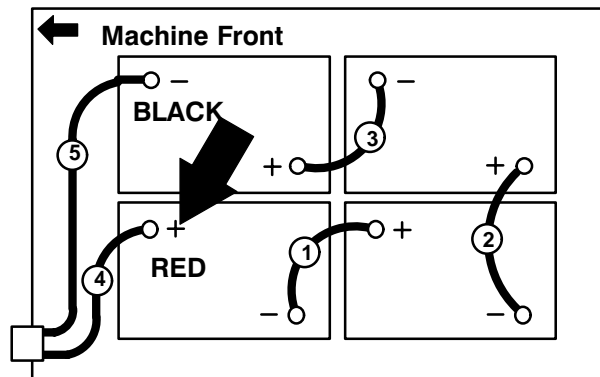

ELECTRICAL

3. Remove the eight pan head screws holding the instrument panel to the handle housing.

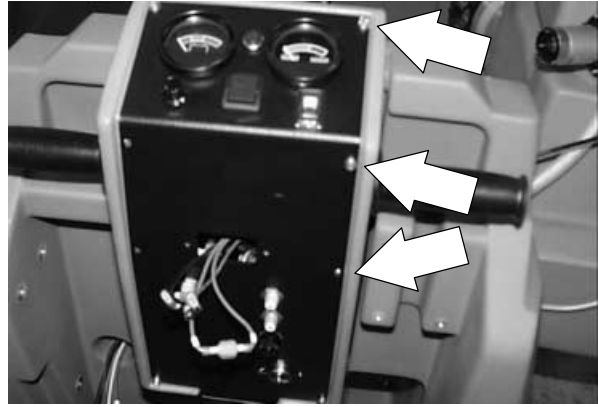

4. Pull the instrument panel back for access to the electrical components.

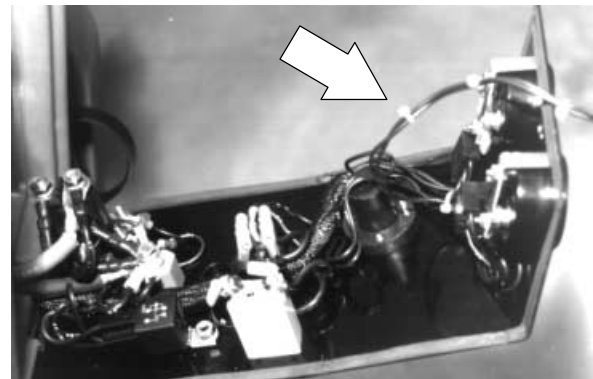

5. When reinstalling the panel, reconnect all wires that were disconnected. Install the eight phillips head mounting screws. DO NOT over tighten the screws or damage to the female brass insert could occur. Reconnect the positive battery cable.

TO REMOVE HANDLE BAR GEAR HUB

FOR SAFETY: Before Leaving Or Servicing Machine; Stop On Level Surface, Turn Off Machine.

1. Open the instrument panel. See TO ACCESS INSTRUMENT PANEL instructions.

FOR SAFETY: Disconnect the battery connections before working on the machine.

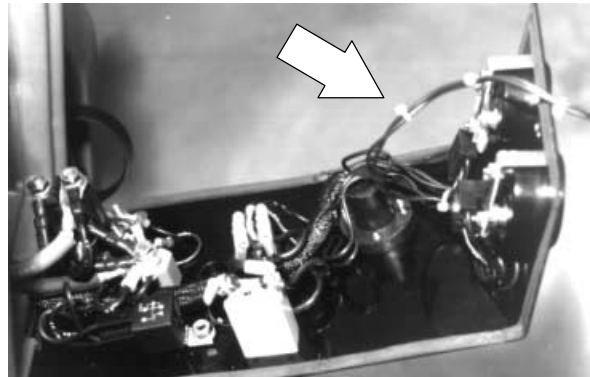

2. Remove the right handle grip.



3. Use a screwdriver to loosen the set screw on the handle bar lock collar. *The collar should now move freely on the handle bar.* Make sure the rounded side of the lock collar is facing OUT, towards the handle grip, when reassembling handle bar.

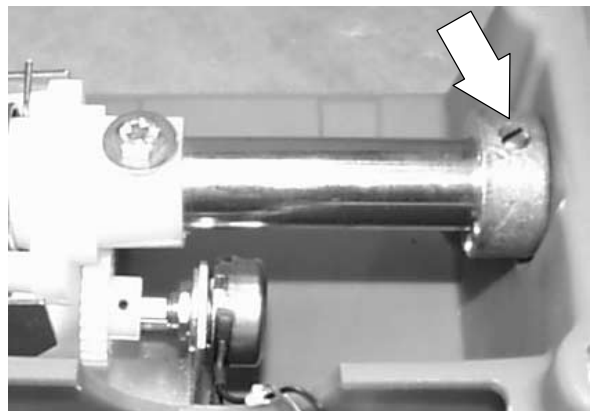

ELECTRICAL

4. Remove the hex screw and nut holding the plastic gear hub to the handle bar.

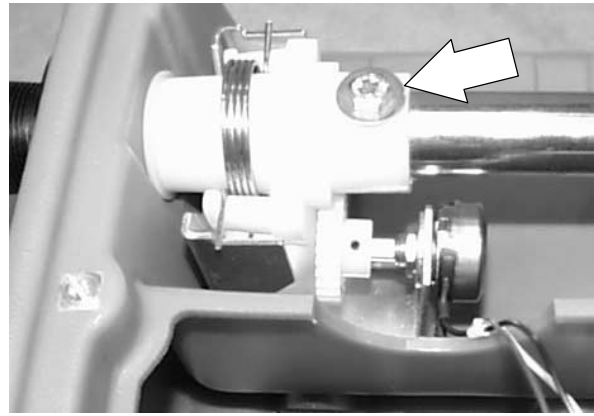

5. Pull the handlebar out of the left side of the console while sliding the gear and hub assembly and shims off the bar. Remove the gear hub from the machine.

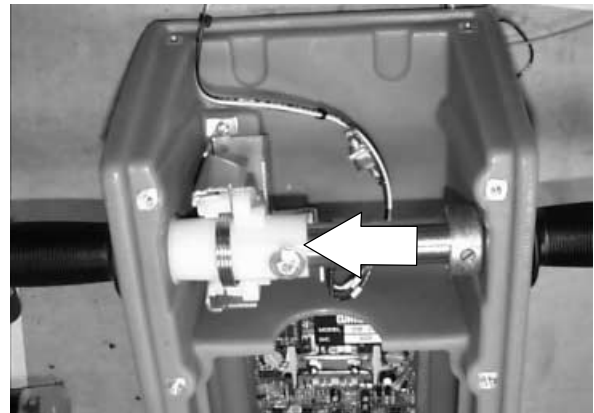

6. To reassemble with a new gear hub, reverse the above steps. When reinstalling the handle grips onto the handlebar, use a light film of alcohol to ease assembly.

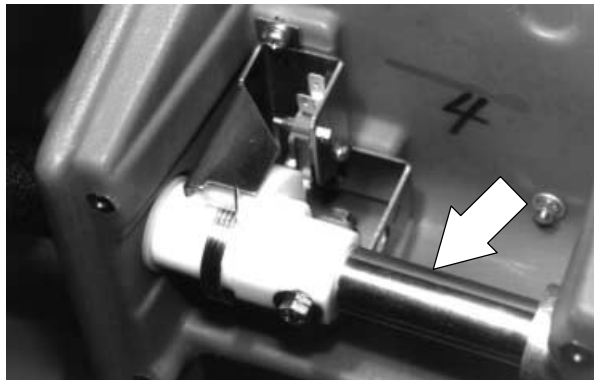

7. Reinstall the instrument panel. See TO ACCESS INSTRUMENT PANEL instructions.



8. Operate the machine. Check the propelling for proper operation. *Make sure the machine stops propelling when the handles are released.*

TO REPLACE POTENTIOMETER SWITCH

FOR SAFETY: Before Leaving Or Servicing Machine; Stop On Level Surface, Turn Off Machine.

1. Open the instrument panel. See TO ACCESS INSTRUMENT PANEL instructions.

FOR SAFETY: Disconnect the battery connections before working on the machine.

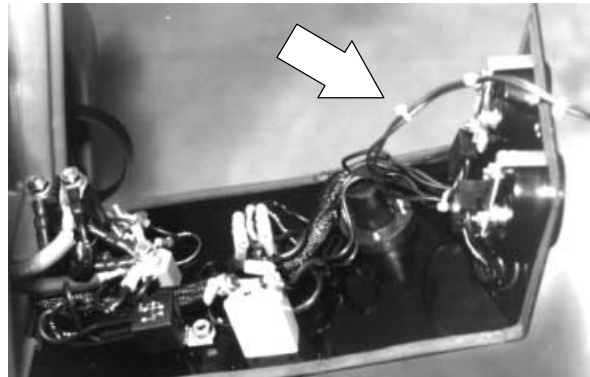

2. Mark the location of the plastic gear on the shaft of the existing potentiometer. Loosen the small set screw and remove the gear from the shaft.

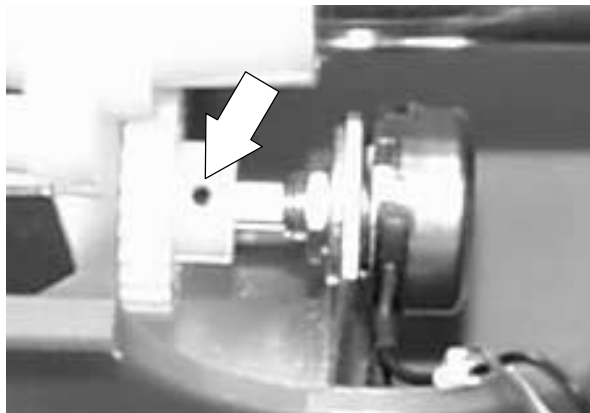

3. Remove the jam nut holding the potentiometer to the mount bracket. *Note the orientation of the potentiometer on the mount bracket.*

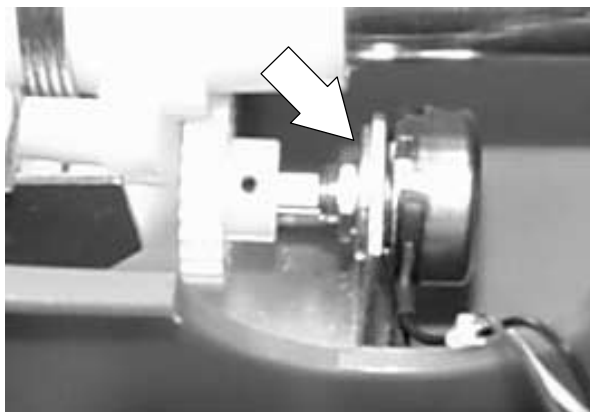

ELECTRICAL

4. Disconnect the potentiometer from the harness and circuit board. Remove the potentiometer from the machine.

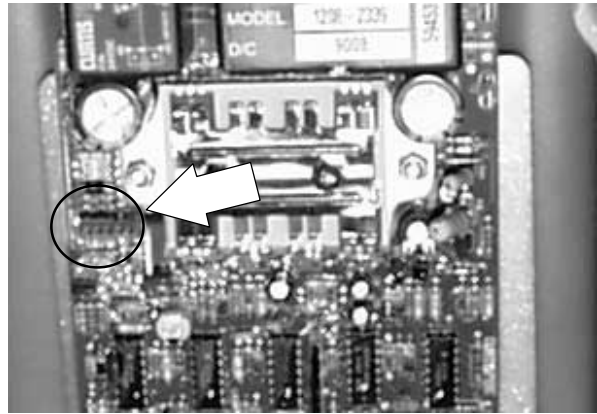

5. Install the new potentiometer onto the mount bracket in the same orientation as the old one. *Leave the jam nut loose for now.*



6. Reinstall the plastic gear onto the shaft of the new potentiometer. *Make sure the gear is in the same orientation on the shaft as the old one.*

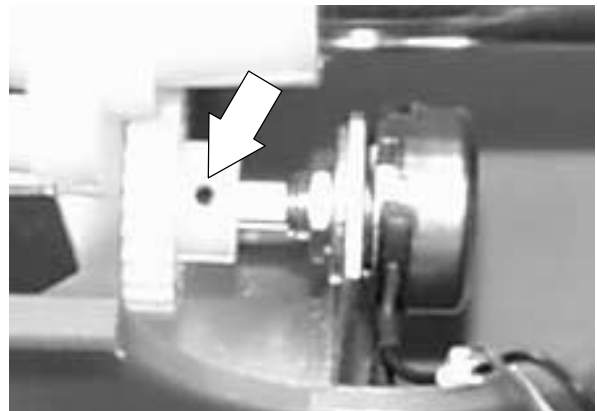

7. See TO ADJUST POTENTIOMETER instructions in this section.

8. Adjust the new potentiometer so that the teeth on the gear fully engage the teeth on the hub and gear assembly. *Make sure not to push the gears too tightly together so they bind. Tighten the potentiometer jam nut. DO NOT over tighten the jam nut or damage to the switch may occur.*
9. Reinstall the instrument panel. See TO ACCESS INSTRUMENT PANEL instructions. Operate the machine. Check the propelling for proper operation. *Make sure the machine stops propelling when the handles are released.*

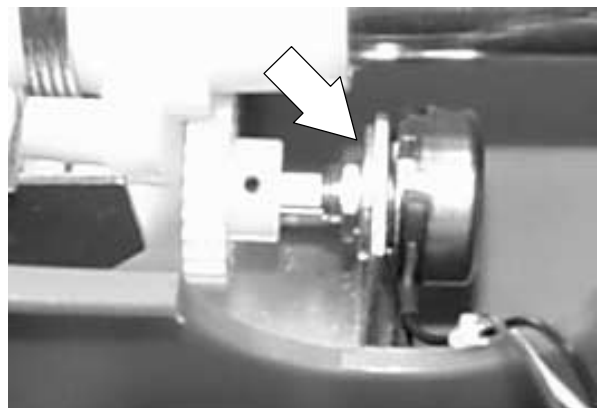

TO ADJUST POTENTIOMETER

FOR SAFETY: Before Leaving Or Servicing Machine; Stop On Level Surface, Turn Off Machine.

1. Open the instrument panel. See TO ACCESS INSTRUMENT PANEL instructions.

FOR SAFETY: Disconnect the battery connections before working on the machine.

2. Locate the potentiometer just below the handle assembly.
3. Connect the red wires of the potentiometer harness together.
4. Use an Volt/OHM meter to measure across the black and white leads of the potentiometer harness (take measurements at wire connection to potentiometer or at 6 pin connector). Divide this reading by two to calculate the midpoint. *This reading should be approximately 2500 OHMS.*
5. While measuring from the black wire to the red wire, adjust the potentiometer to the midpoint.
6. Without moving the potentiometer shaft, measure from the white wire to the red wire. This reading should be the same as the midpoint in step 4. If not, repeat steps 4 and 5 until the readings are within 100 OHMS.
7. Tighten the set screw of the small plastic gear onto the potentiometer shaft. Re-check steps 4 and 5, re-adjust if necessary.
8. Connect the red wires from the potentiometer harness to the black wires from the potentiometer mounted to the instrument panel.
9. Carefully align the 6 pin connector from the potentiometer harness to the mating connector on the circuit board.
10. Reinstall the instrument panel. See TO ACCESS INSTRUMENT PANEL instructions. Operate the machine. Check the propelling for proper operation. *Make sure the machine stops propelling when the handles are released.*

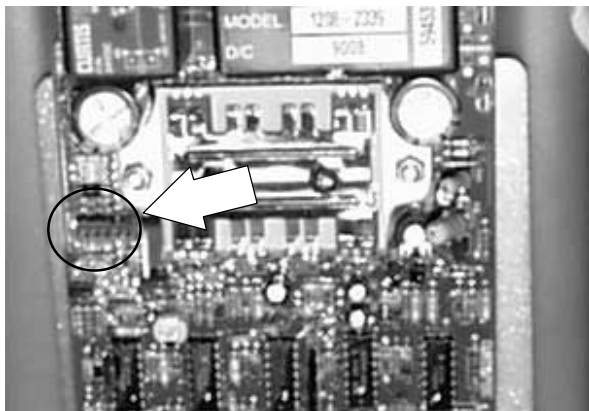
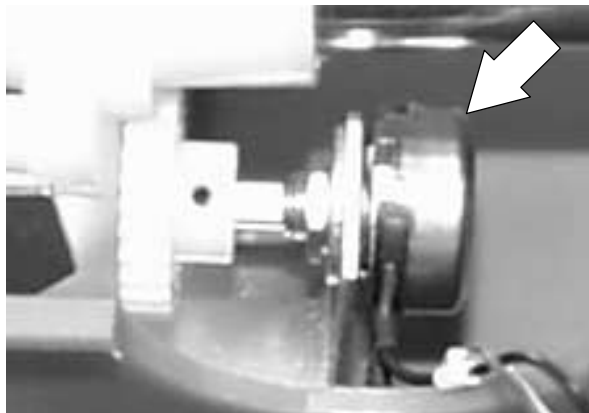
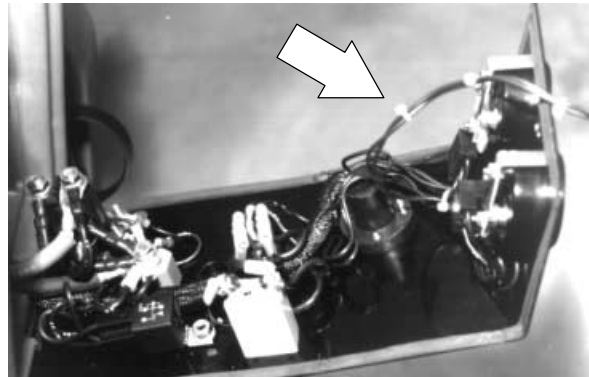

ELECTRICAL

TO REPLACE SPEED CONTROL BOARD

FOR SAFETY: Before Leaving Or Servicing Machine; Stop On Level Surface, Turn Off Machine.

1. Open the instrument panel. See TO ACCESS INSTRUMENT PANEL instructions.

FOR SAFETY: Disconnect the battery connections before working on the machine.

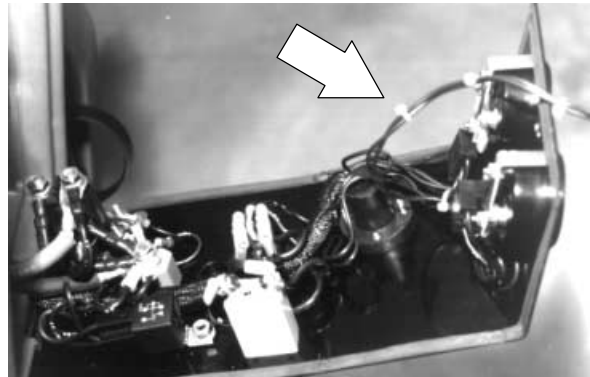

2. Locate the speed control board at the back of the instrument panel box.

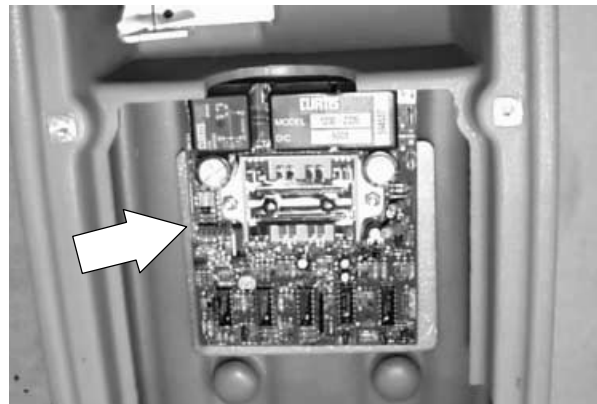

3. Mark and disconnect the wires leading to the speed control board. See electrical schematic in this section.

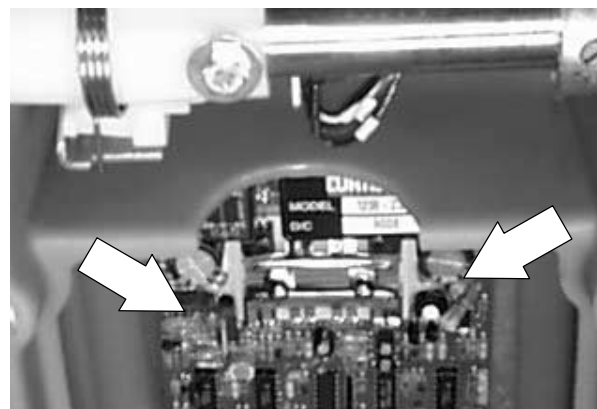

4. Locate the two hex nuts holding the speed control board to the heat sink plate. Remove the hex nuts.

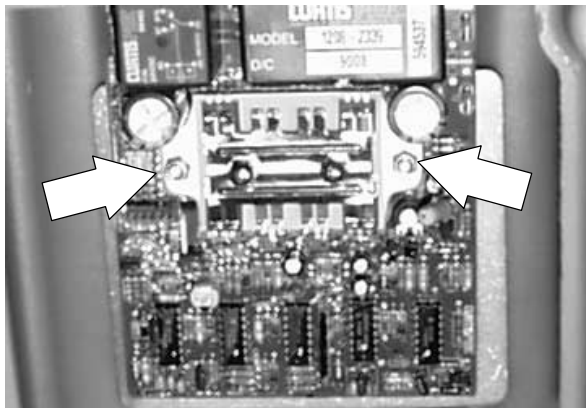

5. Remove the board from the instrument panel. *Make sure to retain the two steel spacers.*

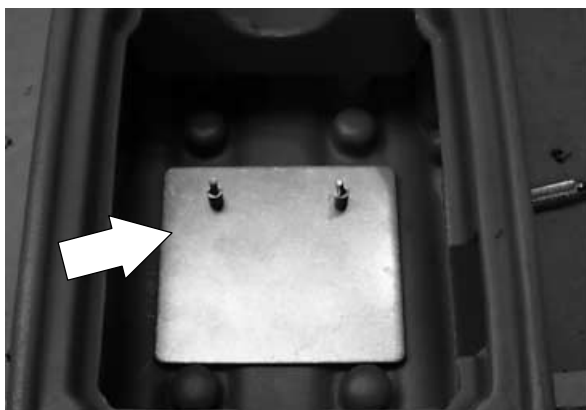

6. Install the new board onto the heat sink plate. Reinstall the two nuts. *Lightly tighten the nuts.*

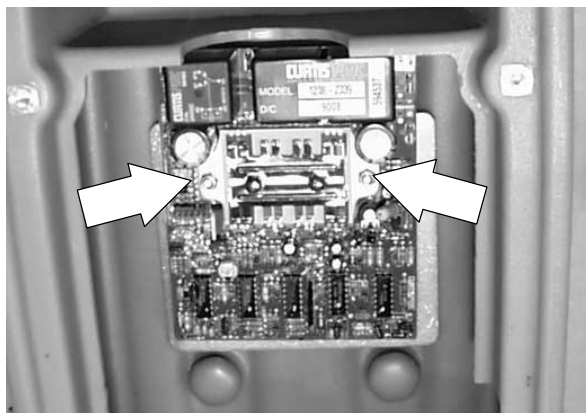

7. Reconnect the wires and connectors to the new board. See electrical schematic in this section.

8. Reinstall the instrument panel. See TO ACCESS INSTRUMENT PANEL instructions.



9. Operate the machine. Check the propelling for proper operation.

ELECTRICAL

TO REPLACE 24 VOLT CONTACTOR

FOR SAFETY: Before Leaving Or Servicing Machine; Stop On Level Surface, Turn Off Machine.

1. Open the instrument panel. See TO ACCESS INSTRUMENT PANEL instructions.

FOR SAFETY: Disconnect the battery connections before working on the machine.

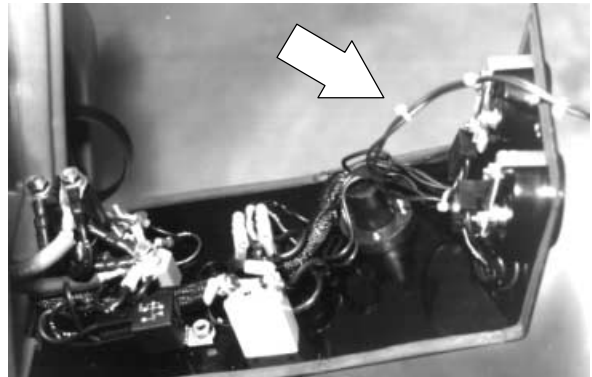

2. Locate the contactor at the bottom edge of the instrument panel box.
3. Mark and disconnect the wires leading to the contactor. **Note the direction of the line side of diode. Make sure the line side is connected to wire 22YEL. Failure to do so will result in a short circuit.**
4. Remove the two hex nuts holding the contactor to the panel. Remove the contactor from the instrument panel.
5. Install the new contactor onto the instrument panel. Install the two nuts and hand tighten tight.
6. Reconnect the wires to the contactor. See electrical schematic in this section. DO NOT over tighten the wire connections on the contactor posts or damage may occur.
7. Reinstall the instrument panel. See TO ACCESS INSTRUMENT PANEL instructions.



8. Operate the machine. Check the vacuum fan for proper operation.



TO REPLACE RESETTABLE CIRCUIT BREAKER

FOR SAFETY: Before Leaving Or Servicing Machine; Stop On Level Surface, Turn Off Machine.

1. Open the instrument panel. See TO ACCESS INSTRUMENT PANEL instructions.

FOR SAFETY: Disconnect the battery connections before working on the machine.

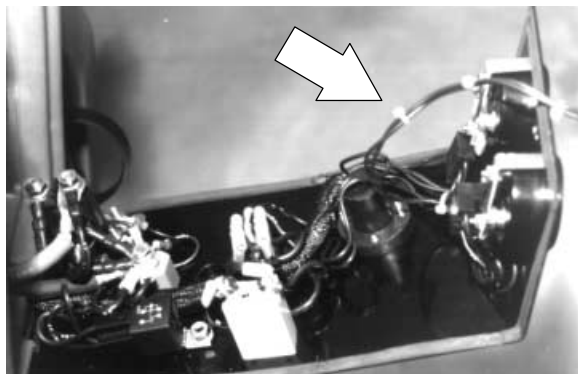

2. Locate the resettable circuit breakers at the center of the instrument panel box.
3. Mark and disconnect the wires leading to the circuit breaker that needs to be changed.
4. Loosen and remove the breakers mounting nut located on the front side of the switch panel.
5. Connect the wires to the new circuit breaker. See electrical schematic in this section.
6. Install the new breaker into the panel. DO NOT over tighten the mounting nut or damage may occur to the breaker.
7. Reinstall the instrument panel. See TO ACCESS INSTRUMENT PANEL instructions.

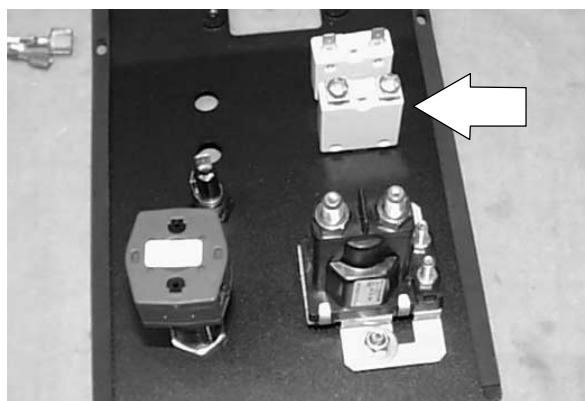

8. Operate the machine. Check the scrub brush for proper operation.

ELECTRICAL

TO REPLACE 24 VOLT SOLENOID

FOR SAFETY: Before Leaving Or Servicing Machine; Stop On Level Surface, Turn Off Machine.

NOTE: Drain the recovery tank.

1. Open the recovery tank.

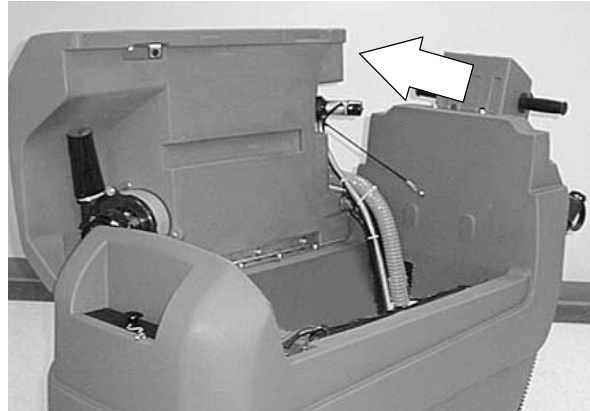

2. Disconnect the positive battery cable from the front, left machine battery.

FOR SAFETY: Disconnect the battery connections before working on the machine.

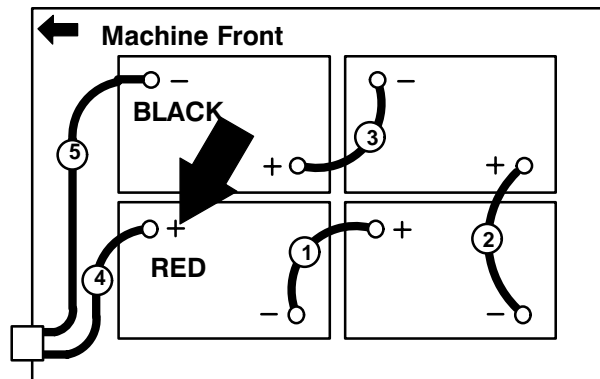

3. Remove the two pan screws holding the hour meter mount plate to the solution tank. Pull the hour meter mount plate up and out of the way.

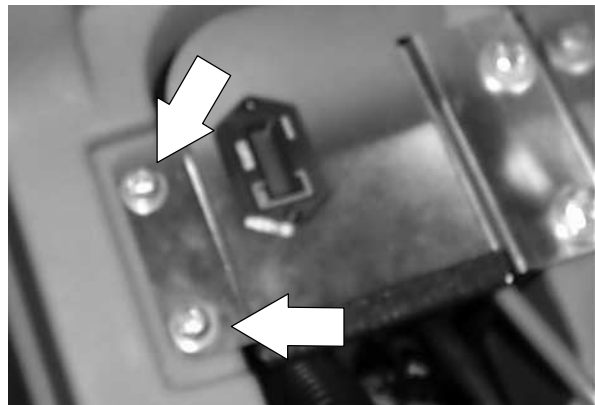

4. Remove the two hex screws holding the solenoid mount plate to the solution tank. Pull the solenoid up for access to the wire connections.

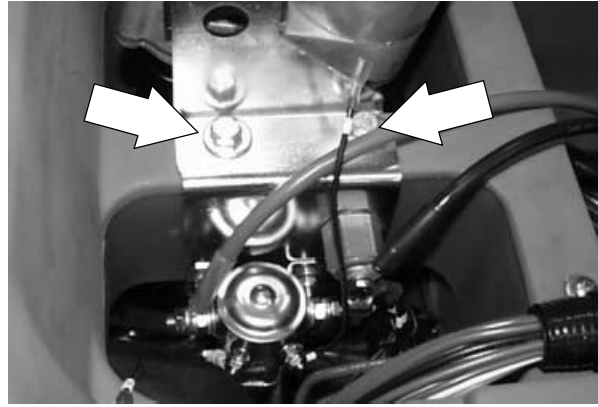

5. Mark and disconnect the wires leading to the solenoid. **Note the direction of the diode connected to the coil terminals. Make sure the line side is connected to wire 16 and 30BLU. Failure to do so will result in a short circuit.**

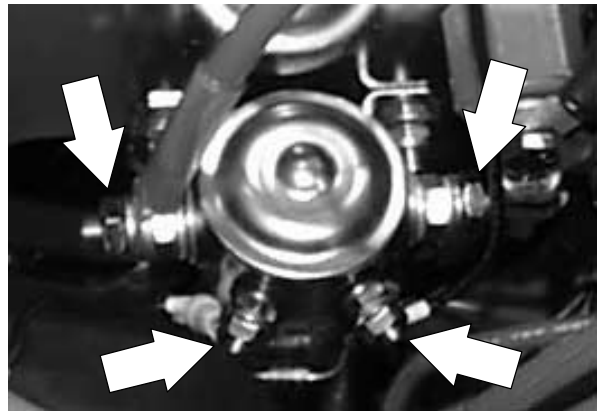

6. Remove the two hex nuts holding the solenoid to the mount plate. Remove the solenoid from the plate.
7. Install the new solenoid onto the plate using the two hex nuts. Tighten to 7 – 9 Nm (5 – 6 ft lb).
8. Reconnect the wires leading to the new solenoid. See electrical schematic in this section.
9. Position the solenoid mount bracket down onto the solution tank. Reinstall the two hex screws and tighten to 18 – 20 Nm (15 – 18 ft lb).
10. Reinstall the hour meter mount plate and two pan screws. Tighten to 7 – 9 Nm (5 – 6 ft lb).

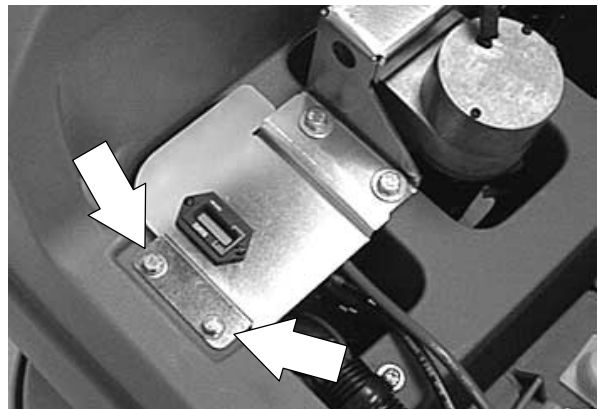
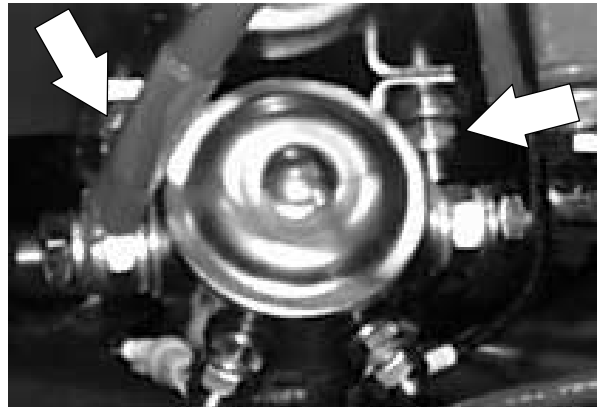

ELECTRICAL

11. Reconnect the positive battery cable to the battery.

12. Operate the machine checking for proper operation.

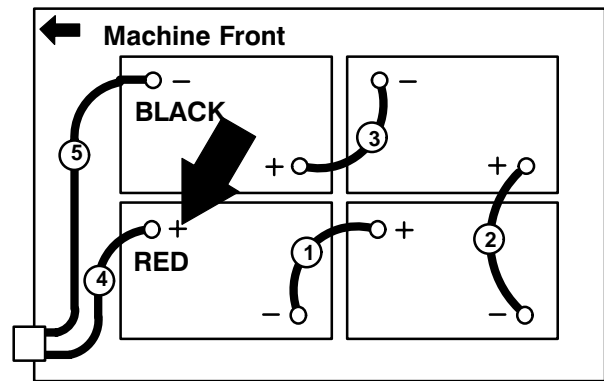

VACUUM FAN

The vacuum fan, when activated, creates a vacuum in the recovery tank. Water is pulled from the rear squeegee to the recovery tank through a vacuum hose.

TO REPLACE VACUUM FAN

FOR SAFETY: Before Leaving Or Servicing Machine; Stop On Level Surface, Set Parking Brake, Turn Off Machine And Remove Key.

NOTE: Drain the recovery tank.

1. Open the recovery tank.

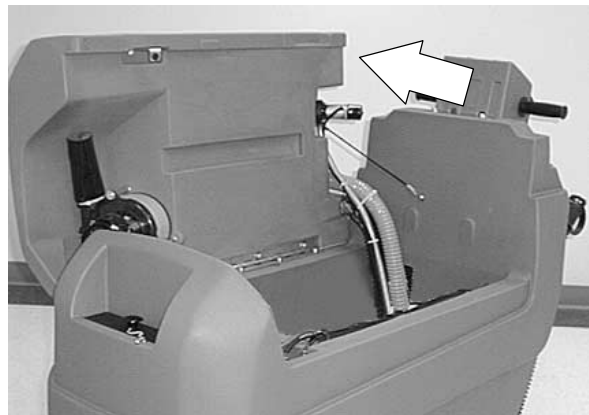

2. Disconnect the positive battery cable from the front, left machine battery.

FOR SAFETY: Disconnect the battery connections before working on the machine.

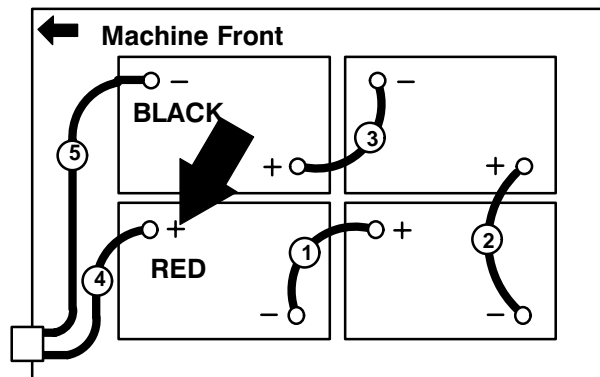

3. Disconnect the vacuum fan from the main harness.

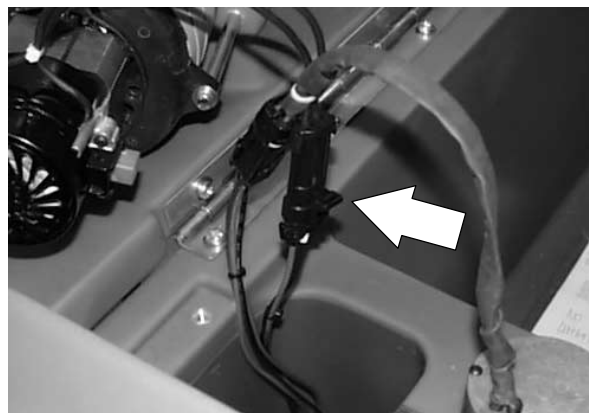

ELECTRICAL

4. Remove the three hex screws holding the vacuum fan to the recovery tank. *Note the orientation of the exhaust port on the fan.* Remove the fan from the recovery tank. *Make sure to retain the three spacers.*

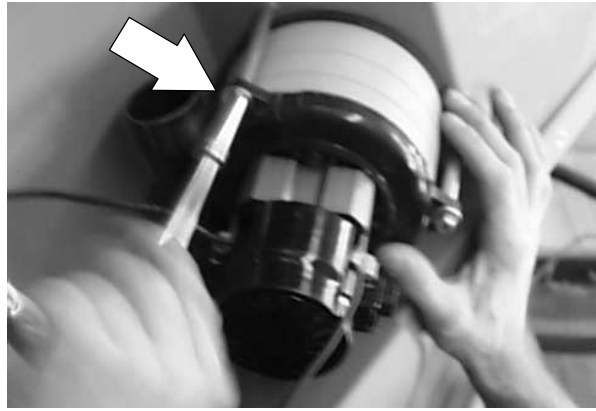

5. Remove the exhaust muffler from the existing fan and install on the new fan using a plastic tie.



6. Install a gasket on the new vacuum fan motor.

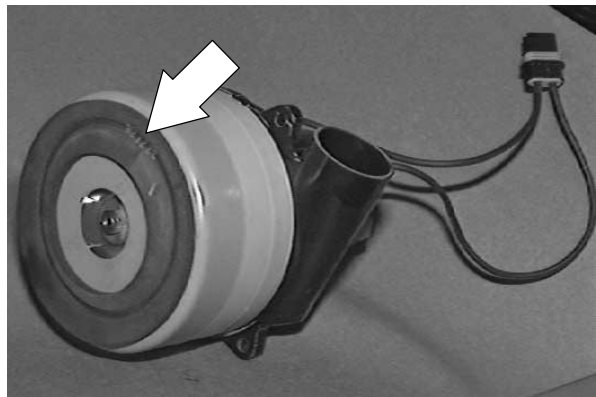

7. Install the new vacuum fan onto the recovery tank. Reinstall the three hex screws and spacers. Tighten to 5 – 6 Nm (50 – 60 in lb).

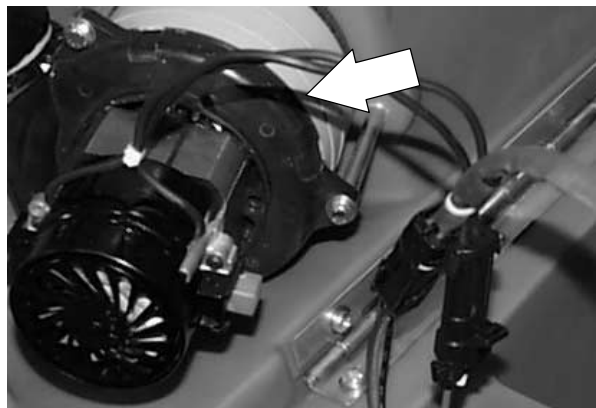

8. Reconnect the vacuum fan to the main harness.

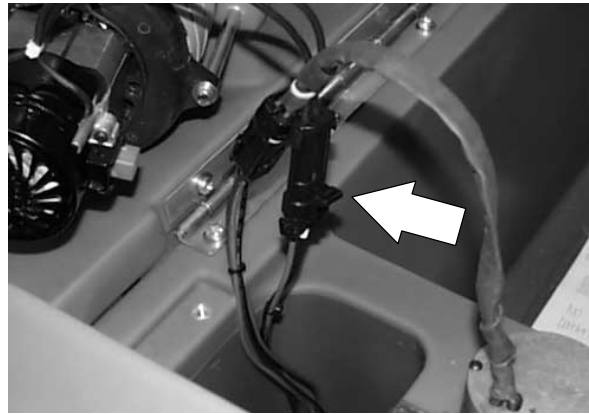

9. Reconnect the positive battery cable to the battery.

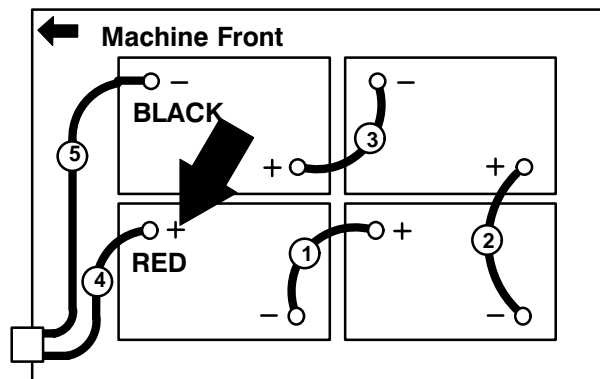

10. Operate the machine. Check the vacuum fan for proper operation.

ELECTRICAL

TO REPLACE VACUUM FAN SWITCH

FOR SAFETY: Before Leaving Or Servicing Machine; Stop On Level Surface, Set Parking Brake, Turn Off Machine And Remove Key.

NOTE: Drain the recovery tank.

1. Open the recovery tank.

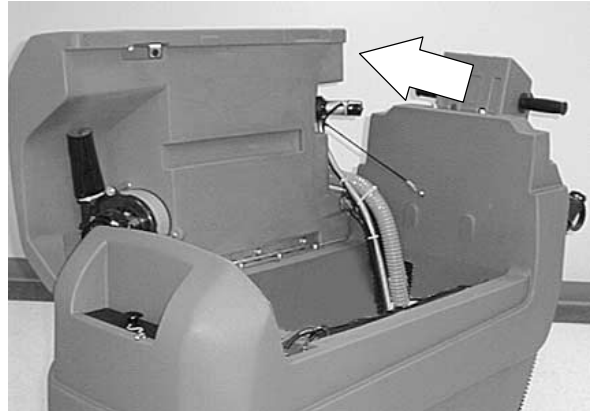

2. Disconnect the positive battery cable from the front, left machine battery.

FOR SAFETY: Disconnect the battery connections before working on the machine.

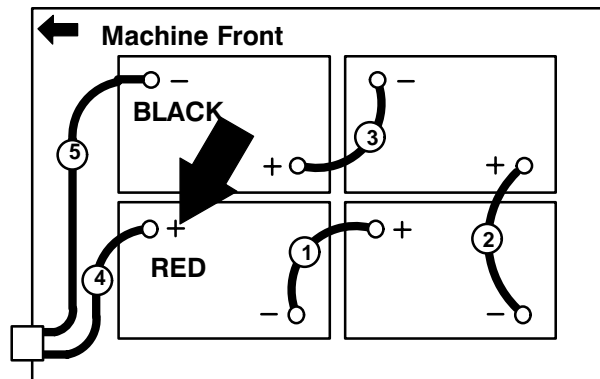

3. Lower the squeegee.



4. Remove the three hex screws holding the squeegee lever bracket assembly to the left side of the solution tank.

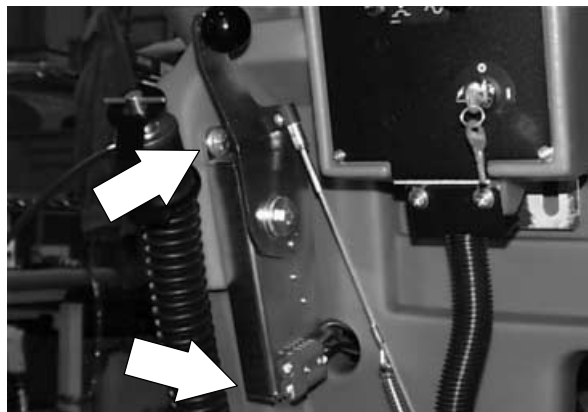

5. Locate the vacuum fan switch at the middle of the lever bracket assembly. Mark and disconnect the wires leading to the switch.

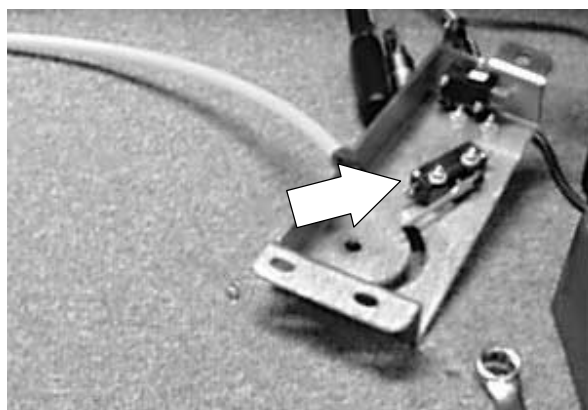

6. Remove the two pan screws and nuts holding the vacuum fan switch to the bracket. Remove the switch.

7. Install the new switch onto the bracket. Reinstall the pan screws and nuts. Tighten the hardware.

8. Reconnect the wires to the new switch. See electrical schematic in this section.



9. Position the squeegee lever bracket assembly to the left side of the solution tank. Reinstall the three hex screws and tighten to 18 – 20 Nm (15 – 18 ft lb).

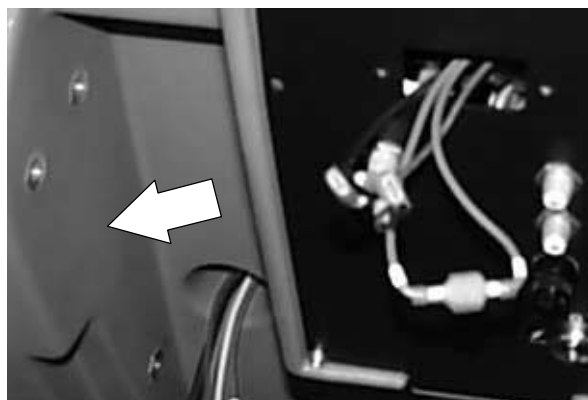

ELECTRICAL

10. Raise the squeegee.

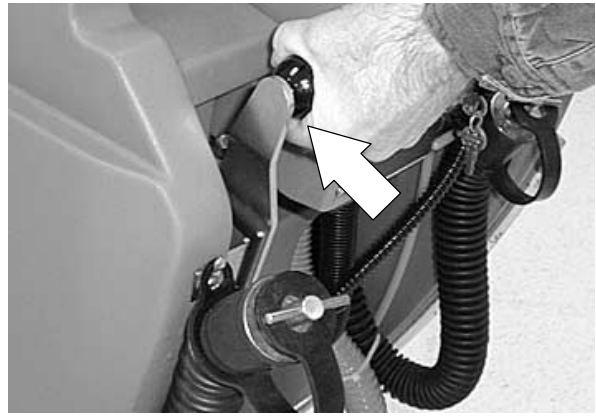

11. Reconnect the positive battery cable to the battery.

12. Operate the machine. Check the vacuum fan switch for proper operation. *Make sure the vacuum fan turns on when the key is on and the squeegee is lowered.*

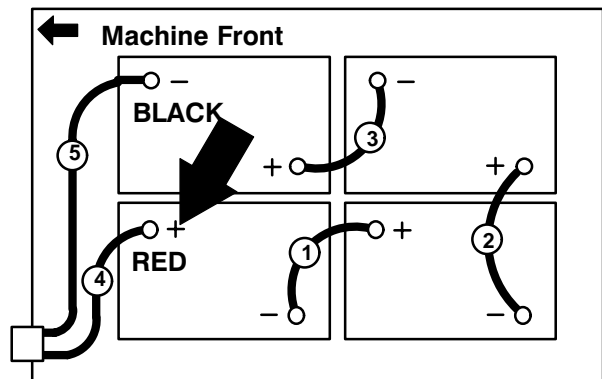

SCRUB BRUSH MOTORS

The scrub brush motors turn the scrub brush. The disc scrub brush motor is direct drive. The cylindrical scrub brush motor uses a drive belt from the motor to the brush.

TO REPLACE DISC SCRUB BRUSH MOTOR

1. Make sure the scrub head is in the raised position. Shut off the key.



2. Remove the scrub head shroud.

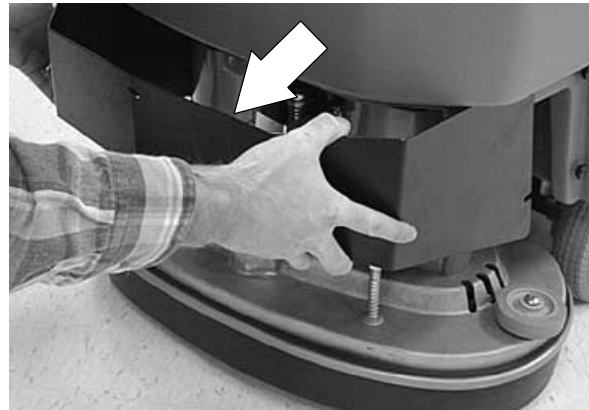

3. Remove the disc scrub brush.

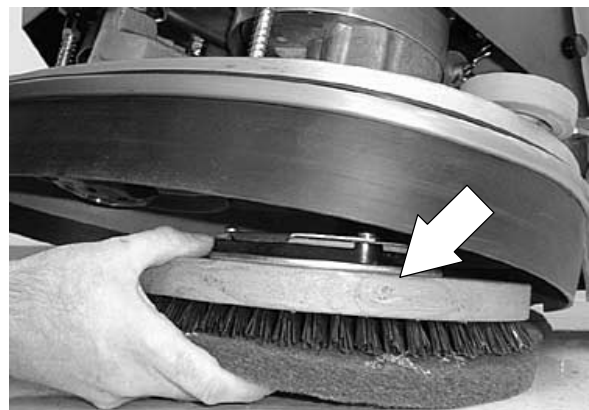

ELECTRICAL

4. Unplug the electrical connectors attaching the scrub head motor to the main harness.

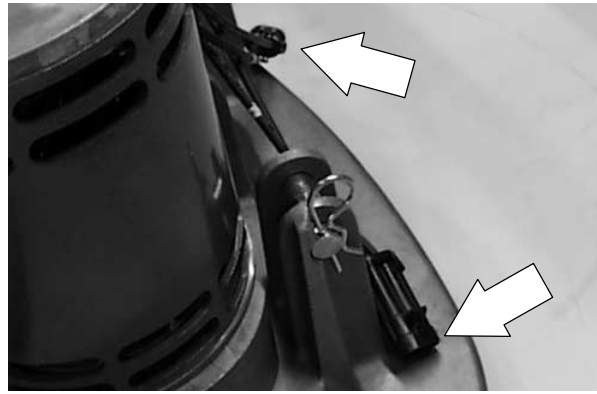

5. Go under the scrub head and remove the 5/16 inch hex screw and washers holding the brush drive hub to the motor shaft.

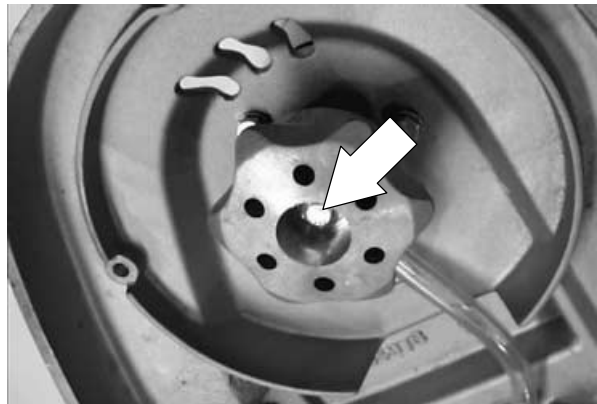

6. Pull the brush drive hub off the brush motor shaft. *Retain the square key and two washers.*

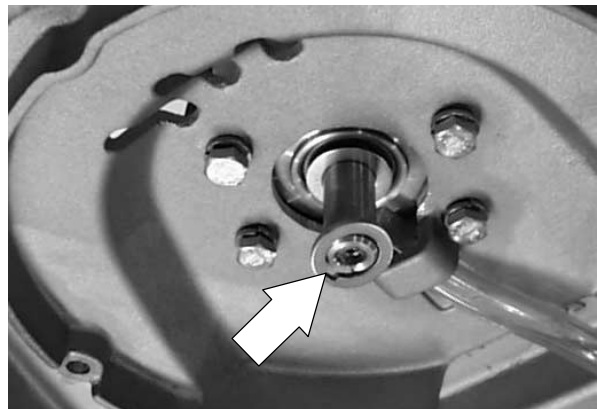

7. Remove the four 3/8 inch hex screws and washers holding the disc brush motor to the scrub head frame.

NOTE: Make sure to mark the location of the existing scrub brush motor on the scrub head. The new brush motor needs to be positioned in the same location. The right hand motor has slots for motor adjustment.

- (The distance between the motor shafts is **12** inch for *24 inch head* and **13** inch for the *26 inch head*).

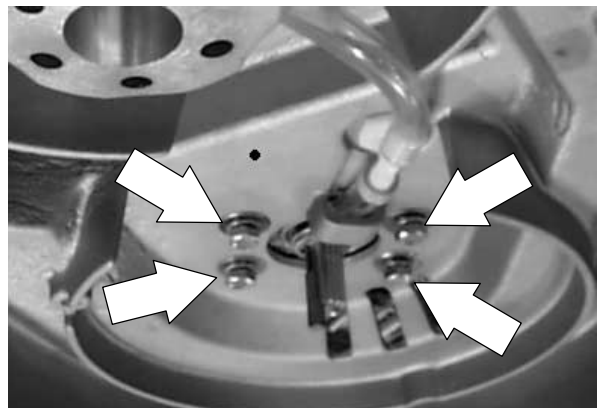

8. Start the machine and lower the scrub head to the floor.



9. Remove the disc scrub brush motor from the machine.

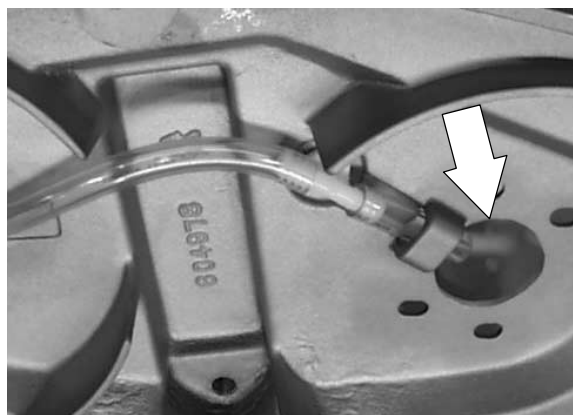

10. Remove the clamp holding the water shroud to the brush motor. Remove the water shroud.



11. Install the water shroud onto the new disc brush motor in the same orientation. The shroud opening should face the center of the scrub head. Tighten the clamp.



ELECTRICAL

12. Position the new disc scrub brush motor onto the scrub head.

NOTE: Make sure to mark the location of the existing scrub brush motor on the scrub head. The new brush motor needs to be positioned in the same location.

- (The distance between the motor shafts is **12** inch for *24 inch head* and **13** inch for the *26 inch head*).

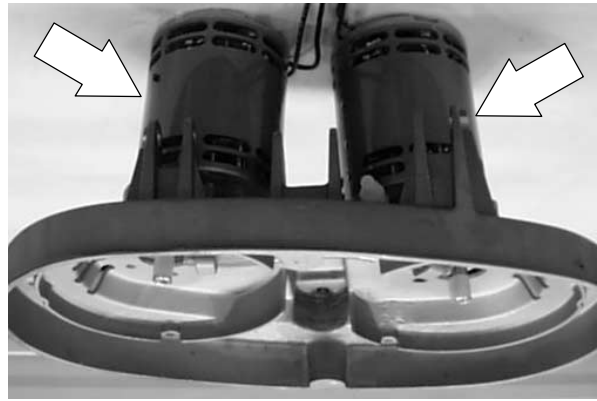

13. Raise the scrub head and turn off the key.

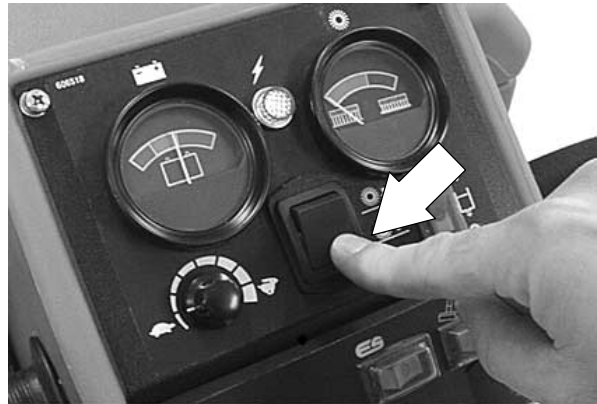

14. Reinstall the four 3/8 inch hex screws and washers holding the disc brush motor to the scrub head frame. *Make sure the motor is installed in the same location. The motor spacing is important for proper brush performance.* Tighten the hardware to 31 – 40Nm (27 – 35 ft lb).

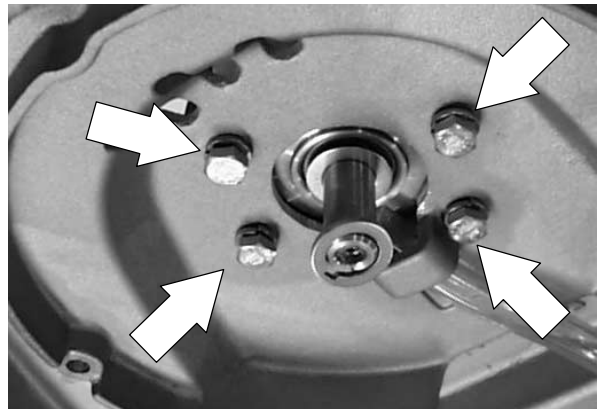

15. Place a small amount of water proof grease on the shaft of the brush motor. *Make sure the square key and thick washer are in place on the shaft.* Position the brush drive hub onto the shaft.

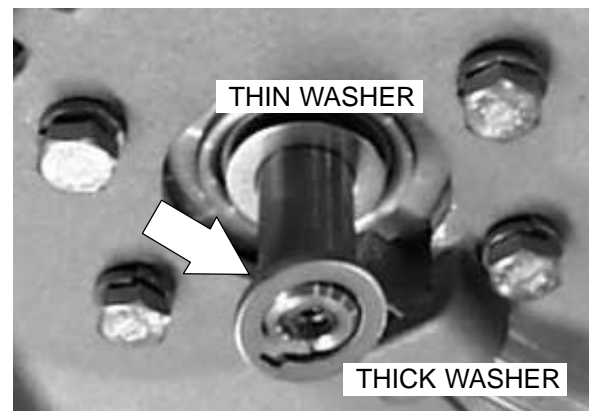

16. Reinstall the 5/16 inch hex screw and washers holding the brush drive hub to the motor shaft. Tighten to 18 – 24Nm (15 – 20 ft lb).

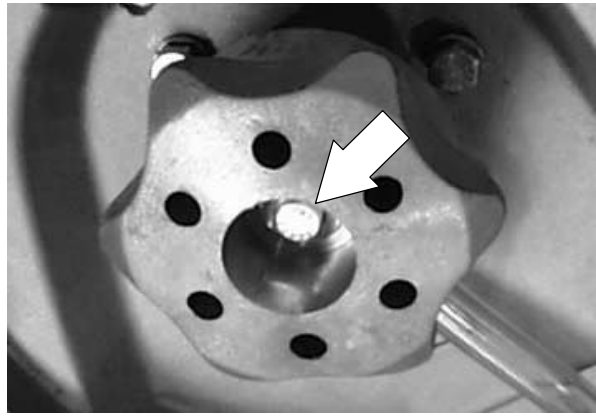

17. Reconnect the scrub brush motor to the main harness.

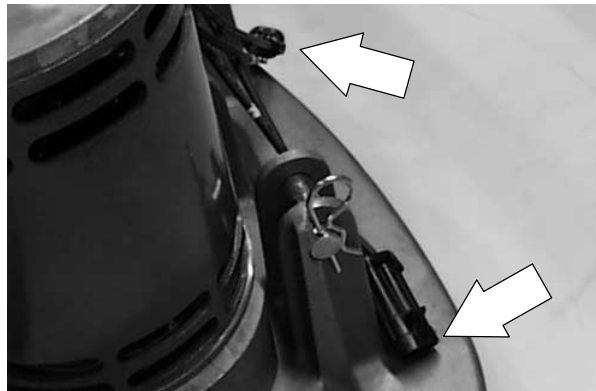

18. Reinstall the disc scrub brush.

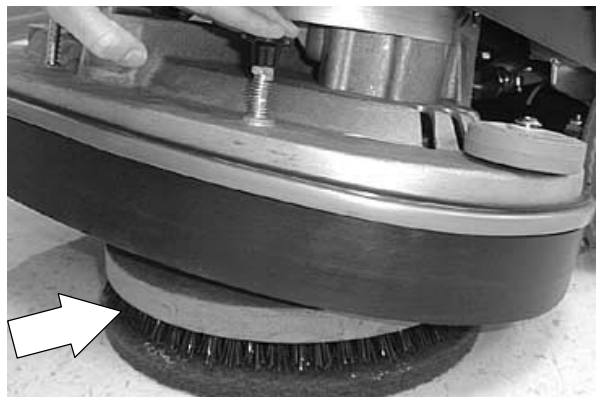

19. Reinstall the scrub head shroud.



20. Operate the machine. Check the new scrub brush motor for proper operation.

ELECTRICAL

TO REPLACE CYLINDRICAL HEAD SCRUB BRUSH MOTOR

1. Start the machine and lower the scrub head to the floor. Shut off the key.



2. Remove the scrub head shroud.

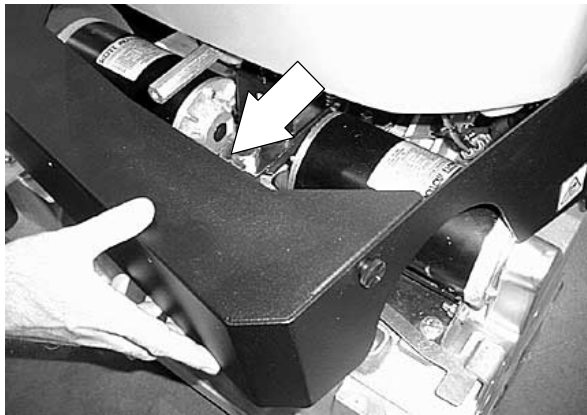

3. Remove the cylindrical scrub brush.



4. Remove the two M6 hex screws holding the belt guard and shield onto the motor that the belt needs changing. *Remove the belt cover from the scrub head.*

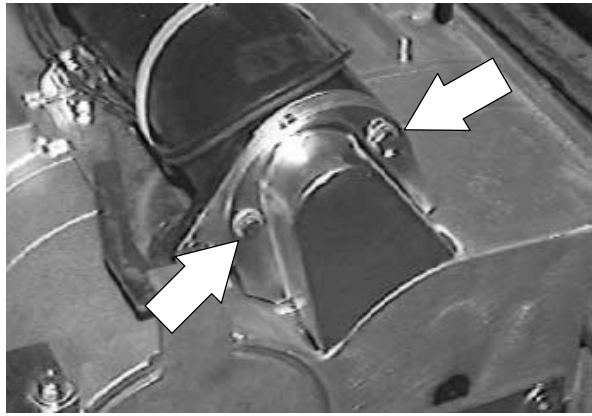

5. Loosen the front and rear pivot bolts on the brush motor.

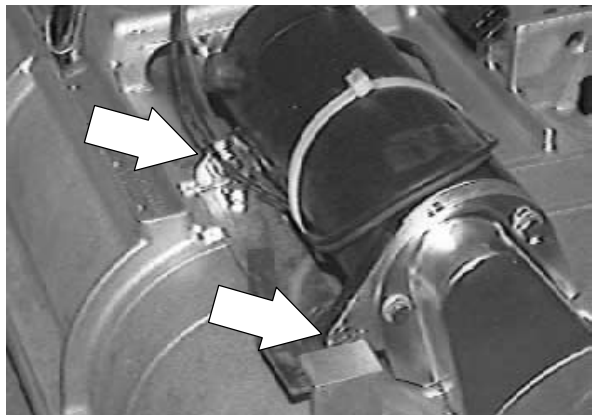

6. Loosen the belt tension bolt.

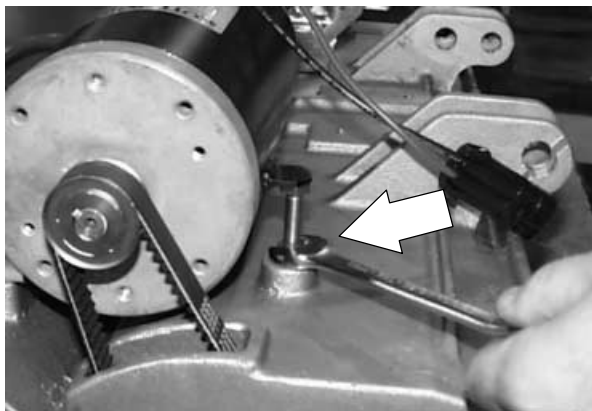

7. Remove the brush drive belt from the motor sprocket.



ELECTRICAL

8. Disconnect the electrical wires from the end of the scrub brush motor.

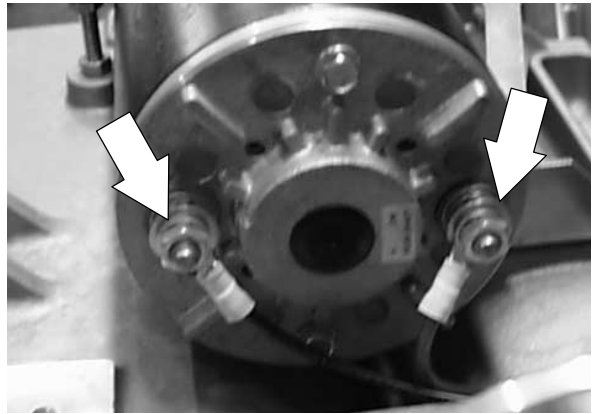

9. Remove the front and rear pivot bolts from the brush motor.

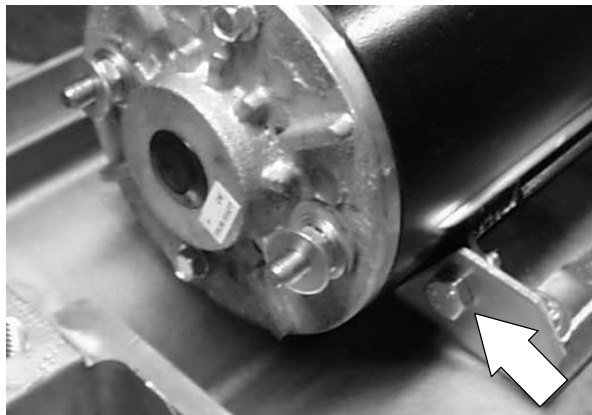

10. Remove the scrub brush motor from the scrub head mounting bracket.

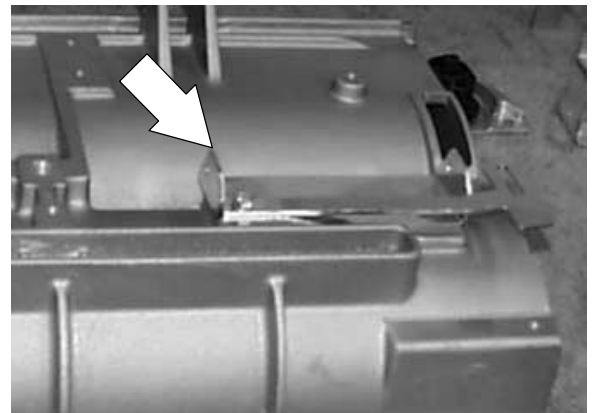

11. Loosen the set screws holding the belt sprocket onto the existing motor shaft. Remove the sprocket.

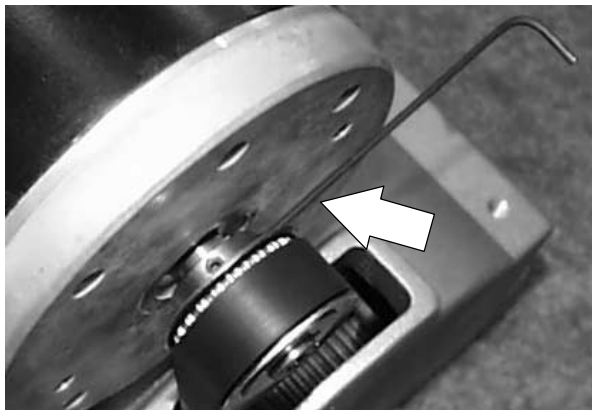

12. Position the new motor onto the scrub head. Reinstall the two pivot bolts and nuts. *Leave loose for now.*

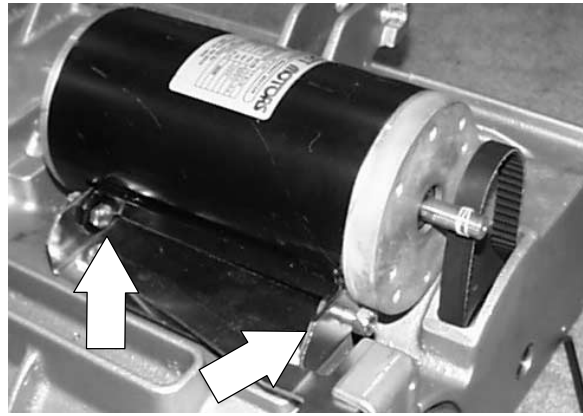

13. Apply grease to the new motor shaft. *Position the belt cover shield on the motor before installing the sprocket.*

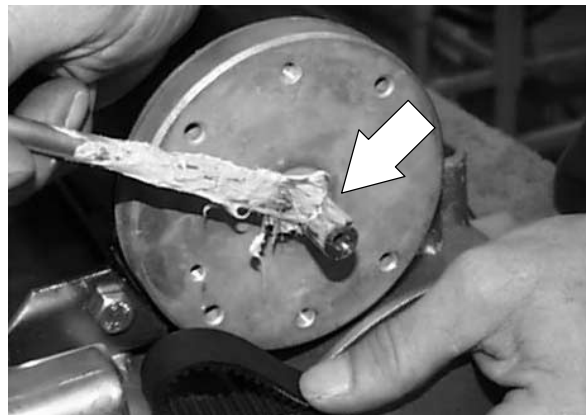

14. Install the belt drive sprocket onto the shaft of the new motor. *Leave the set screws loose for now.* Make sure the square key is in place in the motor shaft.

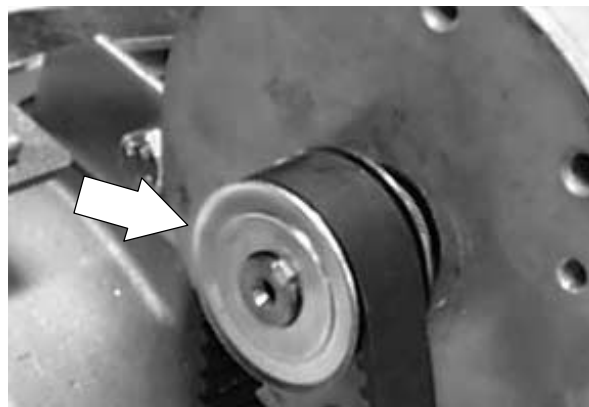

15. Position the cogged brush drive belt over the motor sprocket.

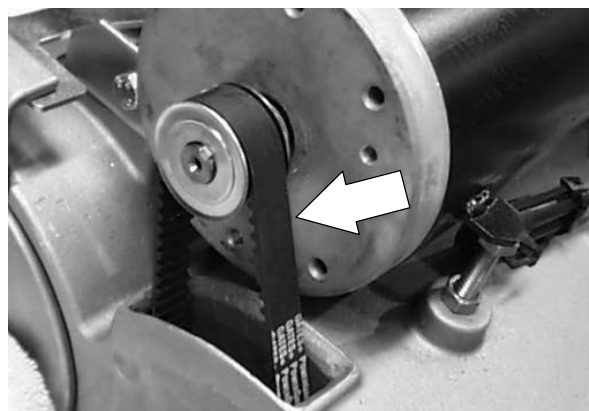

ELECTRICAL

16. Tighten the belt adjustment bolt. Tension the belt by applying 2.5–2.7 lbs of force per belt at the middle of the span that is opposite the belt travel with a deflection of 0.10 inch.

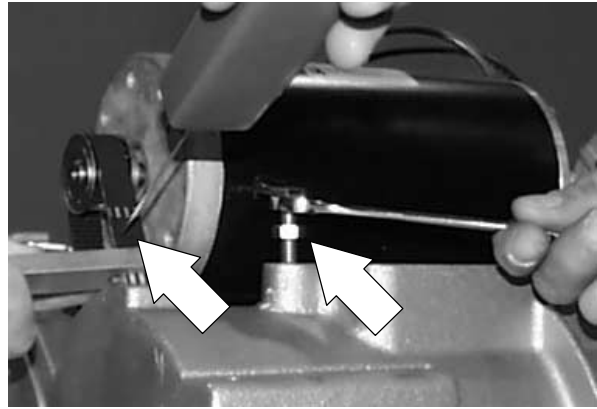

17. Spin the brush drive plug to align the motor sprocket with the lower drive sprocket. Tighten the motor sprocket set screws. *Make sure to apply blue loctite 242 to the set screws before installing.*

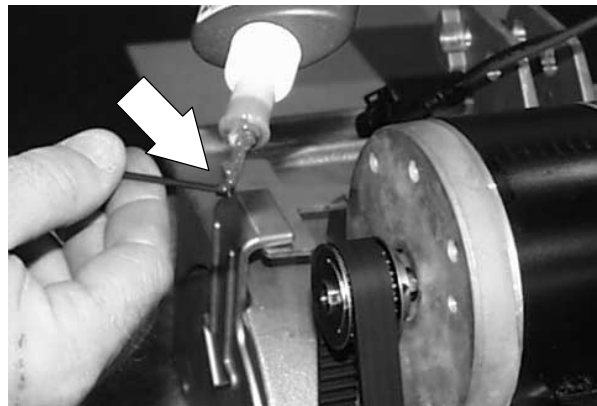

18. Tighten the two pivot bolts to 18 – 24 Nm (15 – 20 ft lb). Re-check the belt tension.

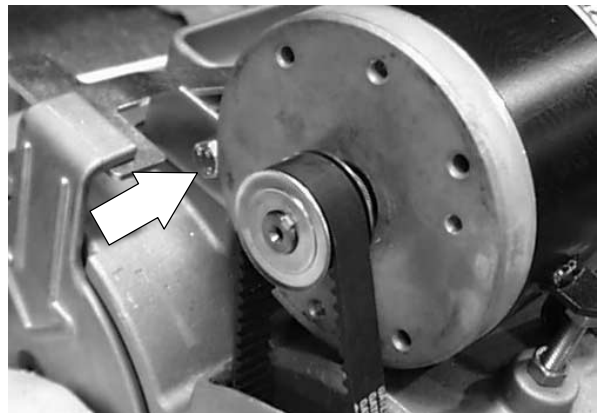

19. Reconnect the brush motor wires to the new brush motor. See schematic in this section. *Make sure to reinstall the washers on the terminal studs on the motor and the rubber boots on the wires.*

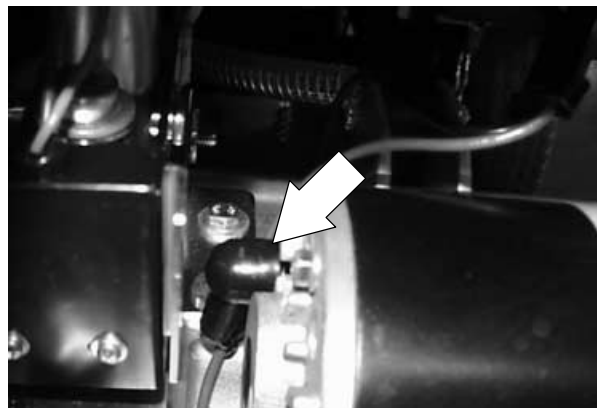

20. Reinstall the belt cover. Install the two M6 hex screws, and washers. Tighten to 11 – 14 Nm (7 – 10 ft lb).

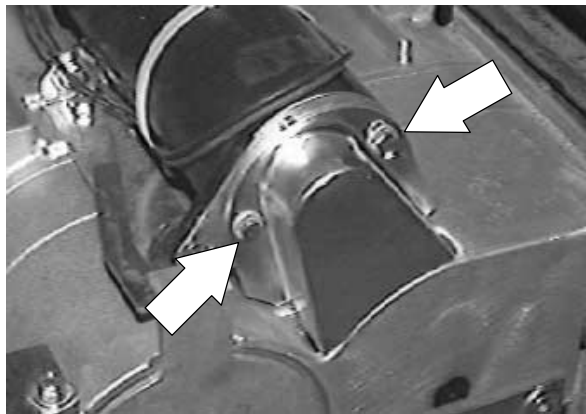

21. Reinstall the scrub brush. See TO REPLACE A CYLINDRICAL SCRUB BRUSH instructions in this section.



22. Operate the machine and check the new motor for proper operation.

ACTUATOR

The 5400 is equipped with a scrub head lift actuator. The lift actuator is used to electrically raise and lower the scrub head.

TO REPLACE SCRUB HEAD LIFT ACTUATOR

FOR SAFETY: Before Leaving Or Servicing Machine; Stop On Level Surface, Turn Off Machine.

1. Lower the scrub head until it just touches the floor.

FOR SAFETY: Before Leaving Or Servicing Machine; Stop On Level Surface, Set Parking Brake, Turn Off Machine And Remove Key.



2. Open the recovery tank.

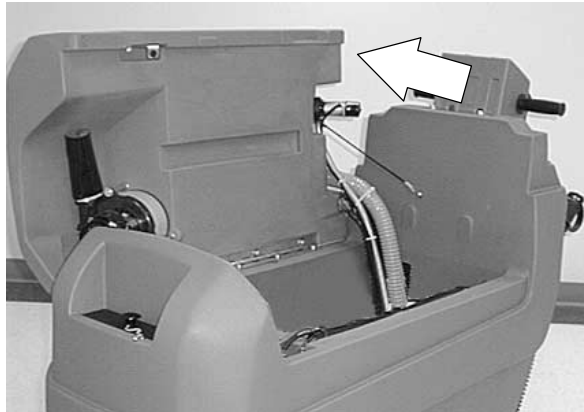

3. Disconnect the positive battery cable from the front, left machine battery.

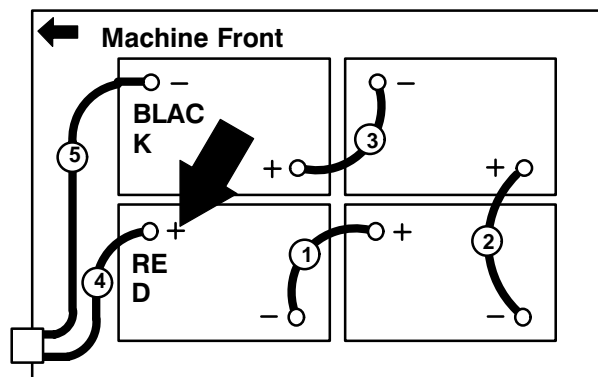

4. Remove the scrub head shroud.

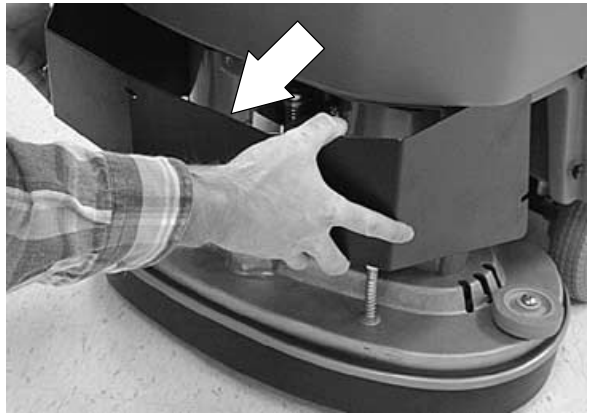

5. Remove the cotter pin and clevis pin holding the bottom of the scrub head lift actuator to the scrub head roller assembly.

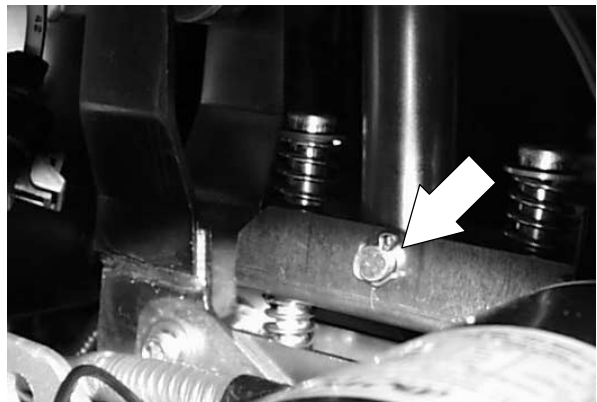

6. Disconnect the lift actuator wire from the main harness.



7. Remove the two pan screws holding the hour meter mount plate to the solution tank. Pull the hour meter mount plate up and out of the way.

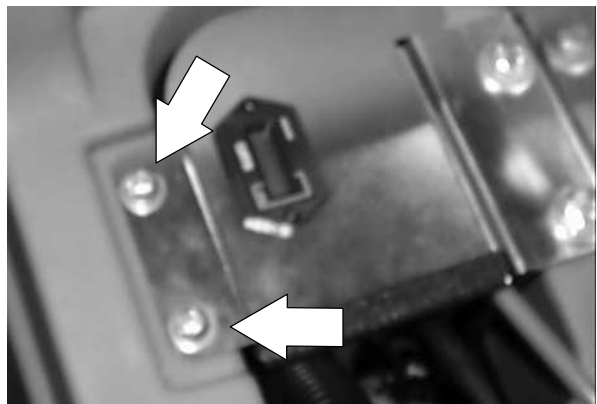

ELECTRICAL

- Remove the four hex screws holding the actuator upper mount bracket to the machine frame. *Move the hour meter bracket and contactor mount bracket out of the way.*
Lift the actuator and mount bracket out of the machine.

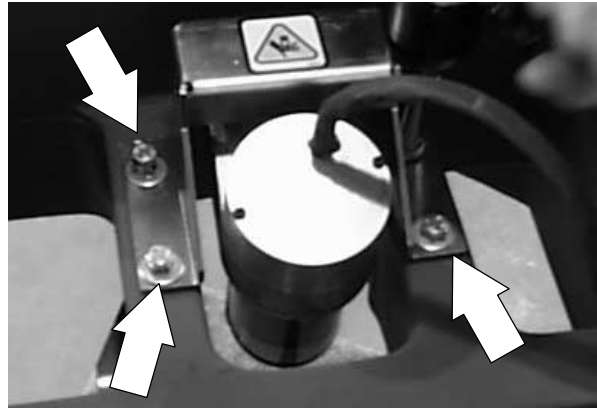

- Remove the hair pin and clevis pin holding the top of the actuator to the mount bracket.

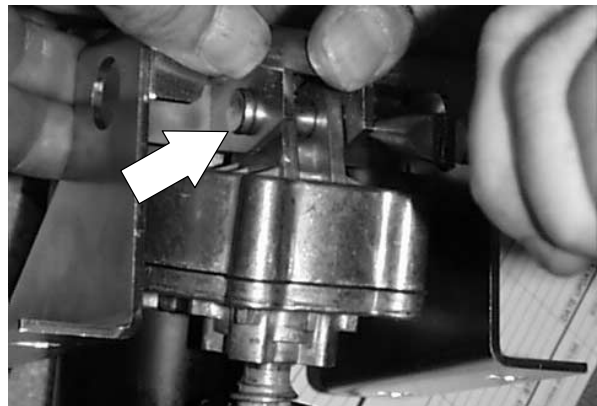

- Remove the mount bracket from the actuator.



- Set the length of the new lift actuator to 13 inches from hole to hole.

- Reinstall the actuator mount bracket onto the top of the new actuator using the clevis pin and hair pin.

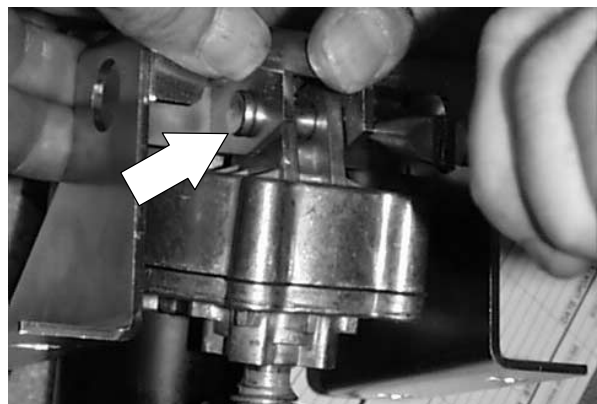

13. Position the new actuator and mount bracket into the machine. Reinstall the contactor mount plate and hour meter mount plate. Install the four hex screws and tighten to 18 – 20 Nm (15 – 18 ft lb).

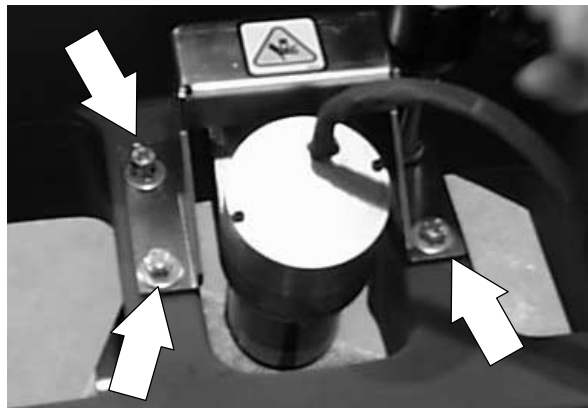

14. Align the hole in the bottom of the new actuator lift tube with the mount hole in the roller assembly. Reinstall the clevis pin and cotter pin.

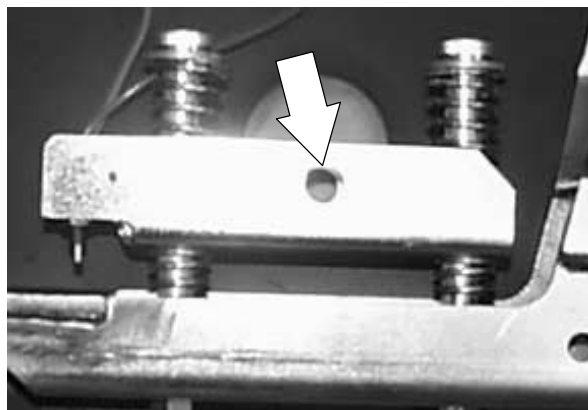

15. Remove the two pan screws holding the hour meter mount plate to the solution tank. Pull the hour meter mount plate up and out of the way.

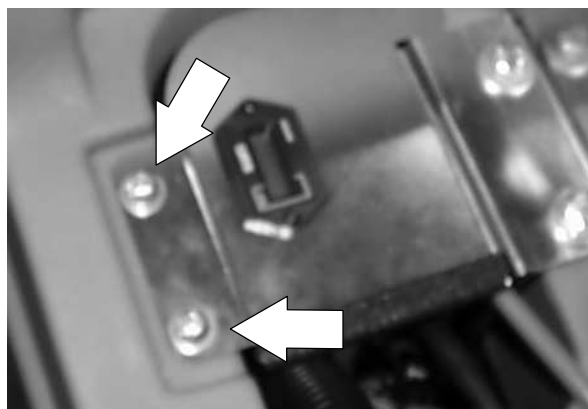

16. Connect the new lift actuator to the main electrical harness.



ELECTRICAL

17. Reconnect the positive battery cable to the battery.

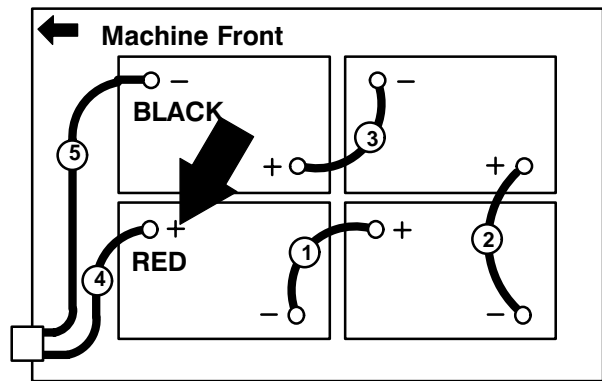

18. Reinstall the scrub head shroud.

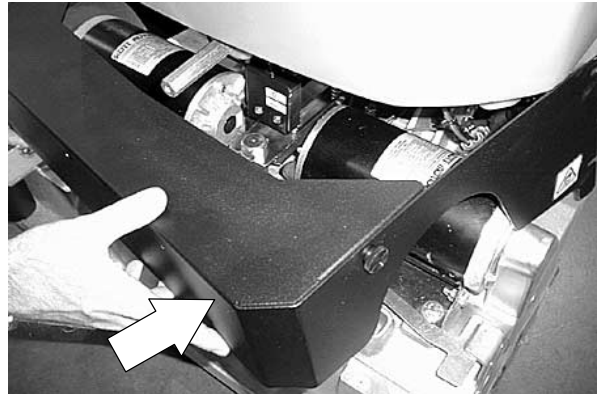

19. Close the recovery tank and operate the machine. Check the scrub head lift actuator for proper operation.

SOLUTION SOLENOID VALVE

The solution valve is an electrically activated device that starts and stops the solution flow to the scrub head with the use of a panel mounted switch.

TO REPLACE SOLUTION SOLENOID VALVE

FOR SAFETY: Before Leaving Or Servicing Machine; Stop On Level Surface, Set Parking Brake, Turn Off Machine And Remove Key.

NOTE: Drain the solution and recovery tanks.

1. Open the recovery tank.

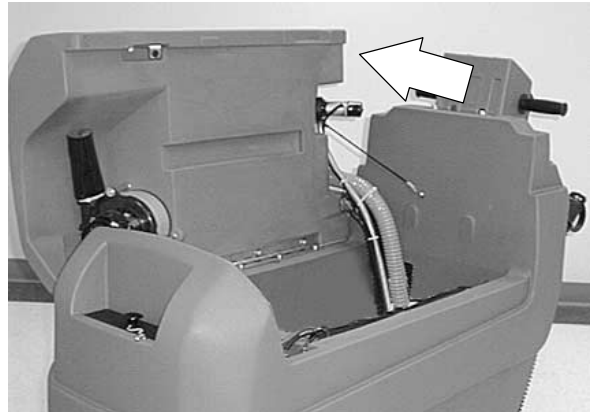

2. Disconnect the positive battery cable from the front, left machine battery.

FOR SAFETY: Disconnect the battery connections before working on the machine.

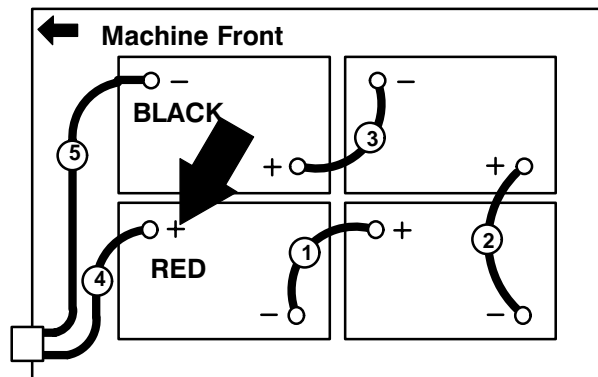

3. Lower the squeegee.



ELECTRICAL

4. Orientate the solution valve and cable so the set screw holding the cable end to the shaft on the valve can be loosened. *Use a 5/64 inch allen wrench to loosen the set screw.*

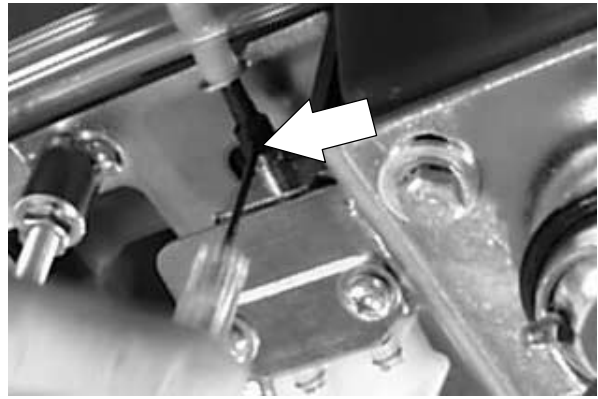

5. Disconnect both solution hoses leading to the valve.

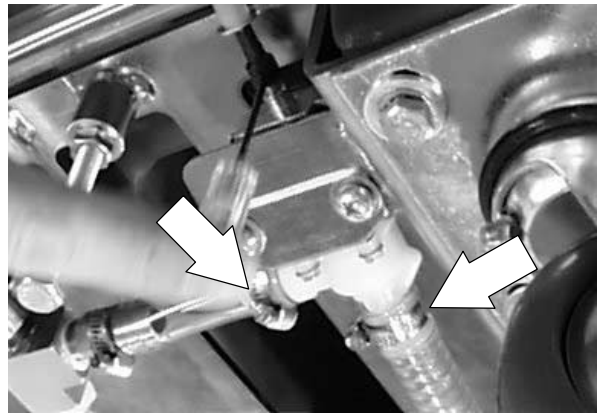

6. Remove the two pan screws holding the solution valve solenoid to the mount bracket.

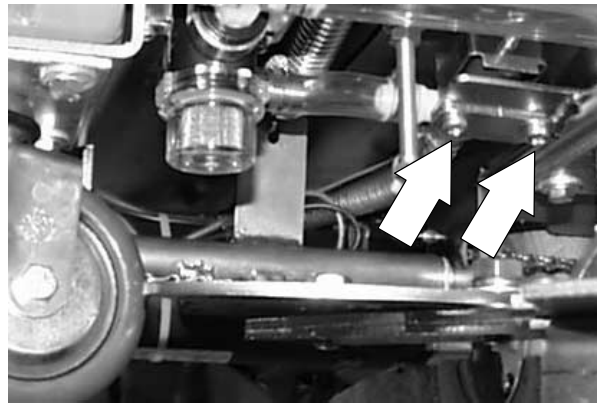

7. Mark and disconnect both wires leading to the existing valve. Remove the valve from the machine. Reconnect the two wires to the new solution valve. *See the schematic in this section. Note the direction of the diode connected to the coil terminals. Make sure the line side of the diode is connected to wire #24 grey. Failure to do so will result in a short circuit.*

8. Install the new solution valve onto the mount bracket. Reinstall the two pan screws and tighten to 7 – 10 Nm (5 – 6 ft lb). *Turn the shaft on the solution control valve clockwise with fingers until resistance is felt. (this closes the valve opening)*

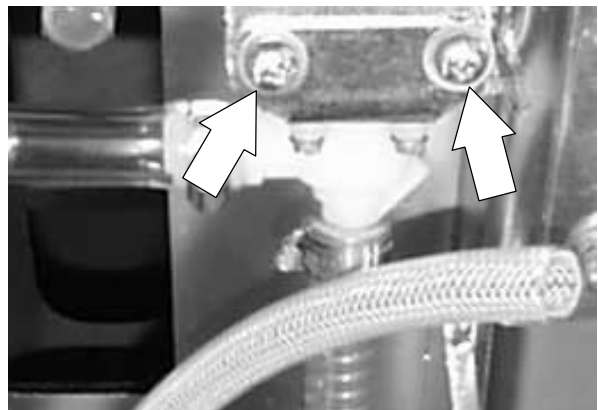

9. Reconnect the two solution lines to the new valve.

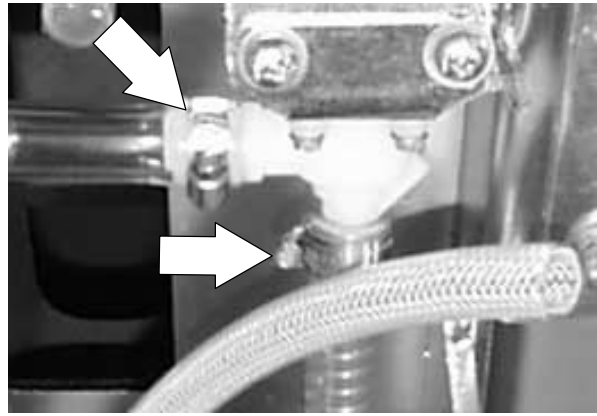

10. Turn the knob, on the water control, at the top of the machine, fully clockwise. (water off position).



11. Reconnect the water control cable to the shaft on the valve. Make sure the set screw seats in the hole on the valve shaft.

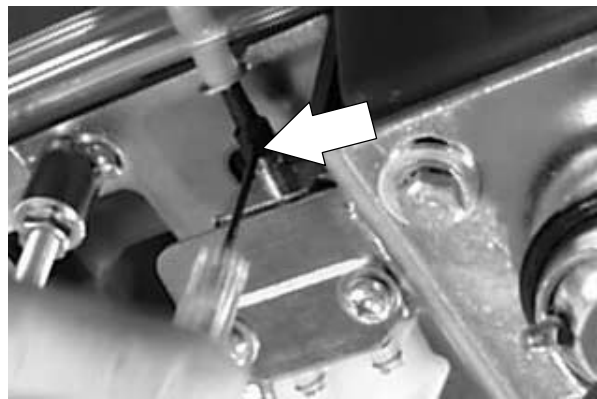

12. Raise the squeegee.



ELECTRICAL

13. Reconnect the positive battery cable to the battery.
14. Operate the machine. Check the solution flow system for proper operation.

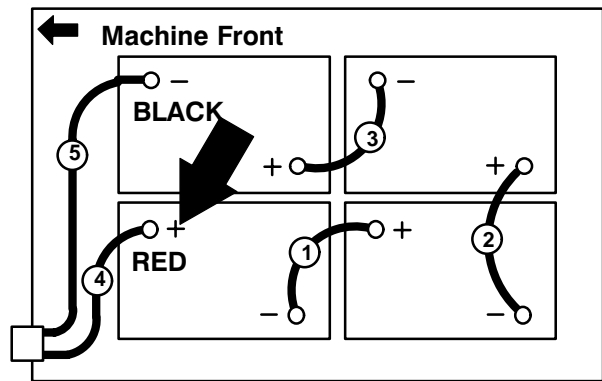

15. *If more or less flow is required, adjust the location of the knob on top of the machine. Loosen the flexible shaft set screw, adjust knob, tighten set screw.*

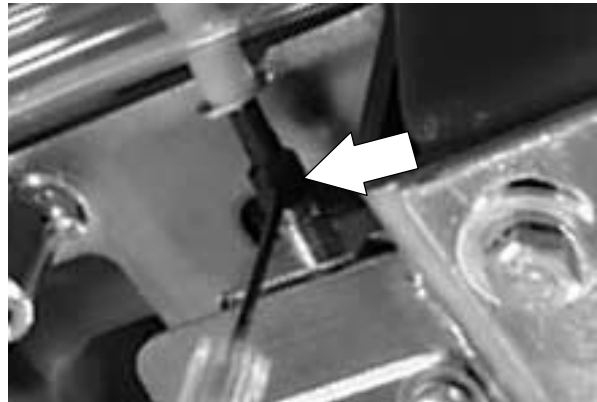

OPTIONAL EXTENDED SCRUB

The ES™ system on the 5400 allows the dirty water in the recovery tank to be filtered and returned to the solution tank to be re-used. This greatly extends the amount of scrubbing that can be done on one fill up. The ES™ system is activated by a switch on the instrument panel.

TO REPLACE THE ES™ PUMP

FOR SAFETY: Before Leaving Or Servicing Machine; Stop On Level Surface, Set Parking Brake, Turn Off Machine And Remove Key.

NOTE: Drain the recovery tank.

1. Open the recovery tank.

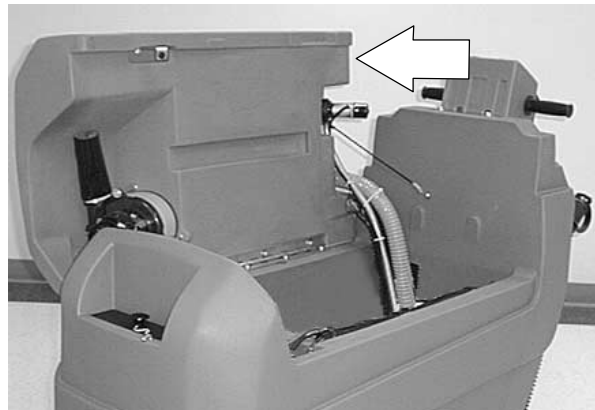

2. Un-plug the ES™ pump from the main harness.

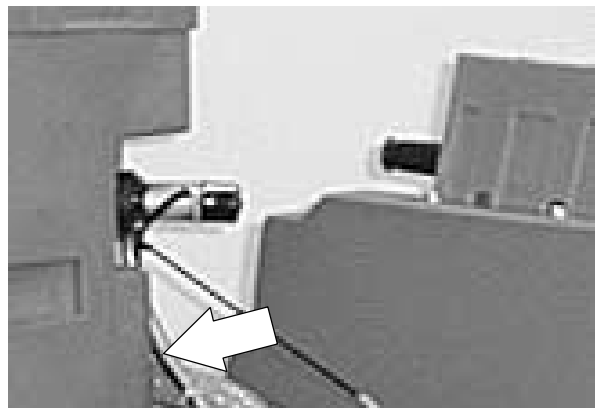

ELECTRICAL

3. Loosen the worm drive clamp on the small outlet hose on the ES™ pump. Remove the hose.

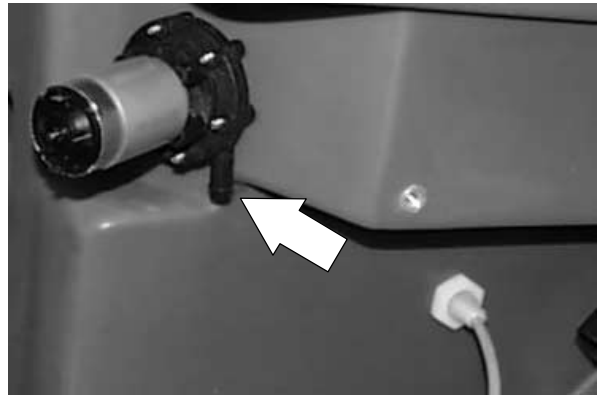

4. Remove the ES™ pump from the tank by un-screwing it counter-clockwise.
5. Put water proof thread sealant on the threads of the new ES™ pump.

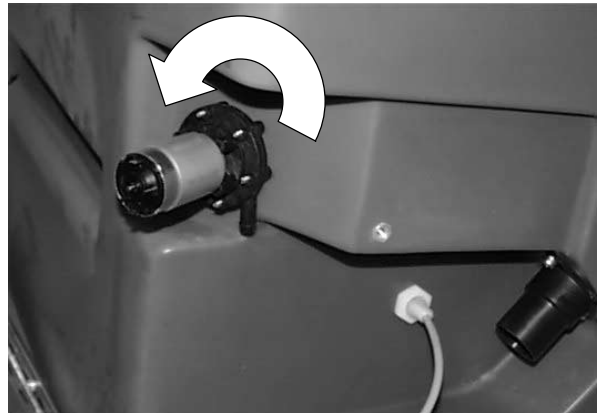

6. Screw the new pump clockwise into the recovery tank. Tighten until the outlet tube points towards the back of the machine.

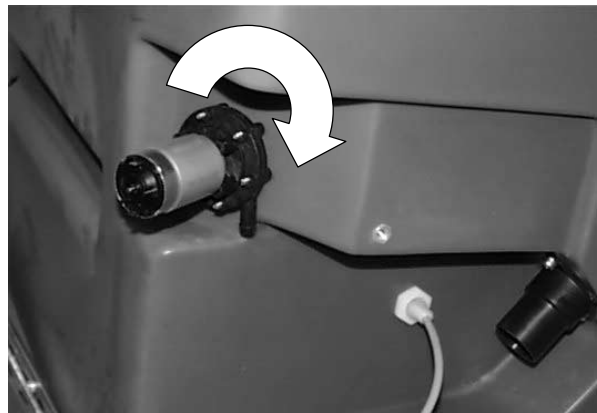

7. Re-connect the small water line and worm drive clamp to the ES™ pump.
8. Re-connect the main wire harness to the new pump. See schematic in the ELECTRICAL section of this manual.
9. Close the recovery tank, operate the machine and check the ES™ pump for proper operation.

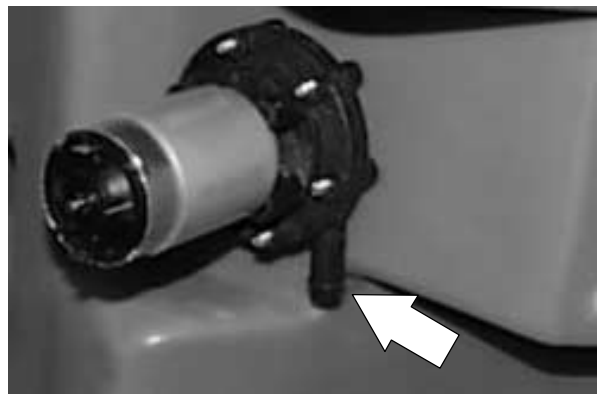

OPTIONAL POWER WAND

The power wand uses the machine's vacuum and solution systems. The power wand allows scrubbing of floors that are out of reach of the machine.

TO REPLACE POWER WAND PUMP

FOR SAFETY: Before Leaving Or Servicing Machine; Stop On Level Surface, Set Parking Brake, Turn Off Machine And Remove Key.

1. Drain the solution tank.
2. Locate the power wand pump at the bottom of the machine frame, just in front the transaxle.
3. Disconnect the pump from the main electrical harness.
4. Loosen the worm drive clamps holding the two hoses leading to the solution pump. Remove the hoses from the fittings on the pump.

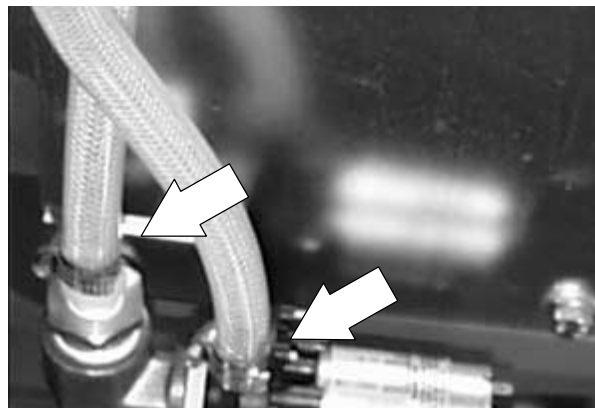
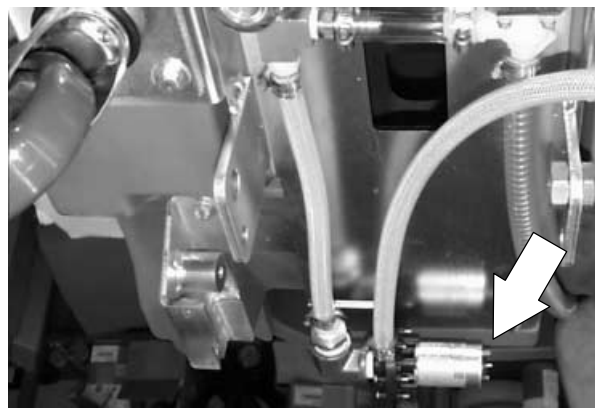

ELECTRICAL

5. Loosen the M8 hex screw holding the pump mount bracket to the frame. Remove the pump and mount bracket assembly from the machine.

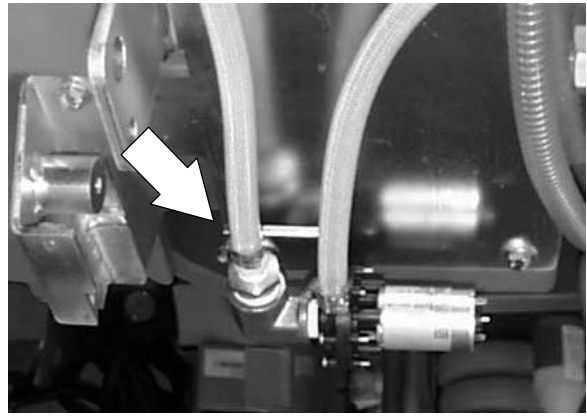

6. Remove the three pan head screws holding the pump to the mount bracket. Remove the pump from the bracket. *Note the orientation of the pump to the bracket.*

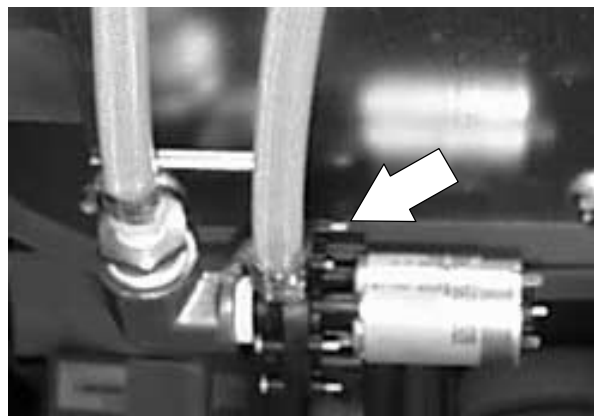

7. Remove the brass elbow from the existing pump. Install the elbow into the new pump in the same orientation. *Use a small amount of thread sealant on the threads of the elbow fitting.*

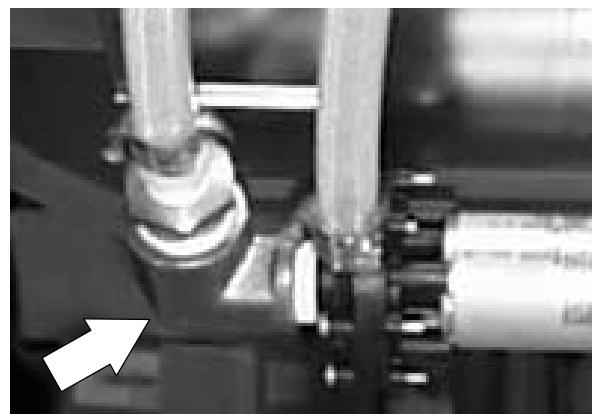

8. Reverse these steps to install a new wand solution pump.
9. Fill the solution tank and check the power wand pump for proper operation.

ELECTRIC MOTORS

The carbon brushes on the vacuum fan motor, scrub brush motor, and propelling motor should be inspected after every 400 hours of machine operation.

TO REPLACE VACUUM FAN MOTOR BRUSHES

FOR SAFETY: Before Leaving Or Servicing Machine; Stop On Level Surface, Turn Off Machine.

1. Remove the vacuum fan from the machine. See TO REMOVE VACUUM FAN instructions in this section.



2. Pry back the locking tabs and remove the fan motor cover.

NOTE : DO NOT operate vacuum fan with the top cover removed.

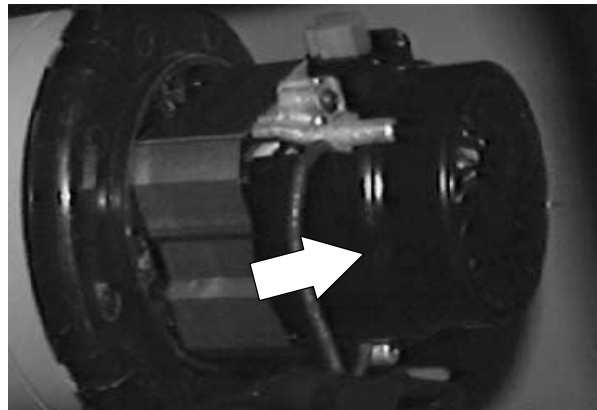

3. Remove the two pan head screws holding the clamp and motor brushes in place. Remove the brushes and measure.
NOTE: If the motor brushes measure 10 mm (0.375 in.) or less in length, install new brushes.



ELECTRICAL

4. If motor brushes replacement is necessary, carefully pull the wire tab connection out of the brush mechanism using a needle nose pliers.
5. Install the wire tab connections into each one of the two replacement motor brush mechanisms.
6. Remount both motor brushes into position using the pan head screws and brush clamps.



7. Reinstall the fan motor cover by pushing down and locking into place.

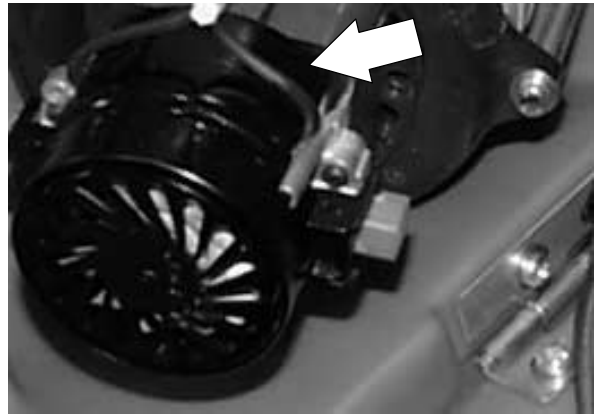

8. Reinstall the vacuum fan motor assembly. See TO INSTALL VACUUM FAN instructions in this section.

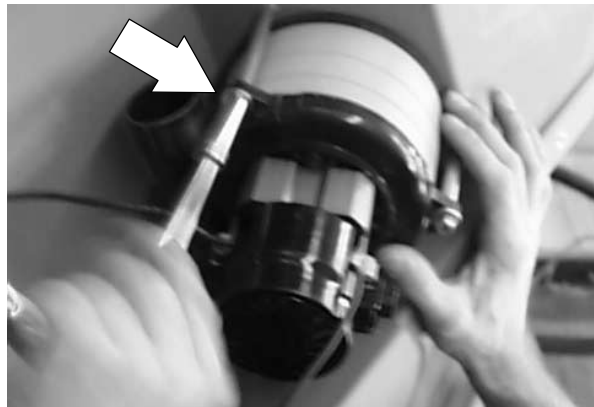

9. Plug the vacuum fan in and start the machine, checking for proper fan operation.

TO REPLACE DISC SCRUB BRUSH MOTOR BRUSHES

FOR SAFETY: Before Leaving Or Servicing Machine; Stop On Level Surface, Turn Off Machine.

1. Remove the disc scrub brush motor. See TO REPLACE DISC SCRUB BRUSH MOTOR instructions in this section.
2. Mark the location of the motor cover on the motor body.

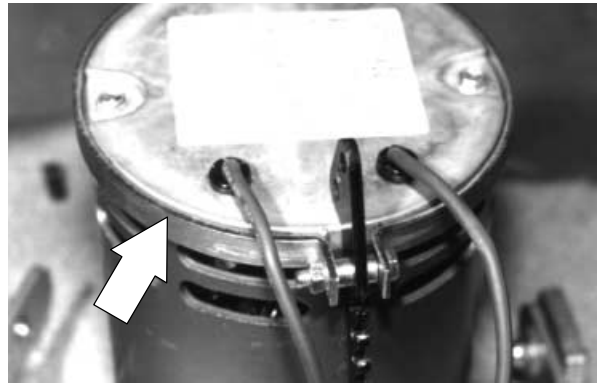

3. Remove the two long bolts holding the top of the motor and motor body together.

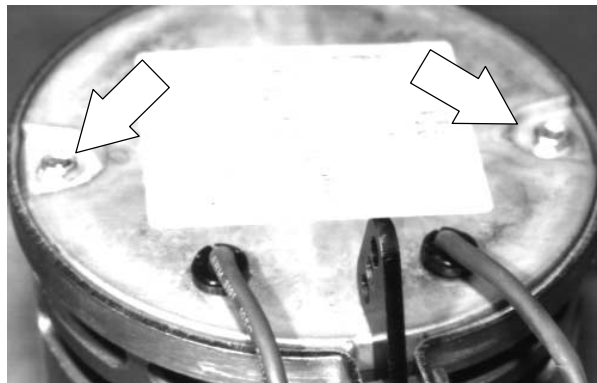

4. Using a hammer and straight screwdriver gently tap and pry the motor top off.



ELECTRICAL

5. Change the motor brushes if worn to 10 mm (0.375) of an inch or less in length.

NOTE: When installing new motor brushes, do not push the brushes completely into the brush holder. Let the brush spring rest on the side of the brush. This will prevent the brushes from hitting the commutator during motor re-assembly. After the top of the motor is properly assembled, push the motor brushes completely into the brush holder using a small screwdriver. The brush springs should snap into position behind the brush. Line-up the marks on the motor and cover to reassemble.

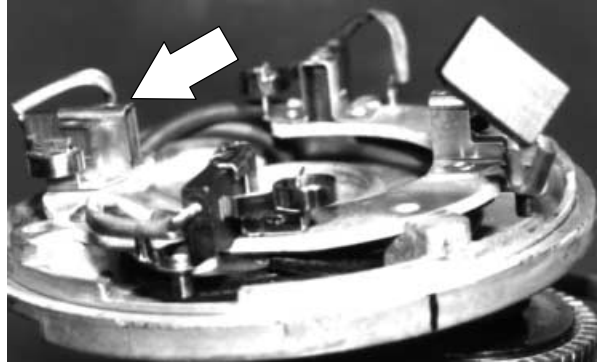

6. Reinstall the disc scrub brush motor. See TO REPLACE DISC SCRUB BRUSH MOTOR instructions in this section.

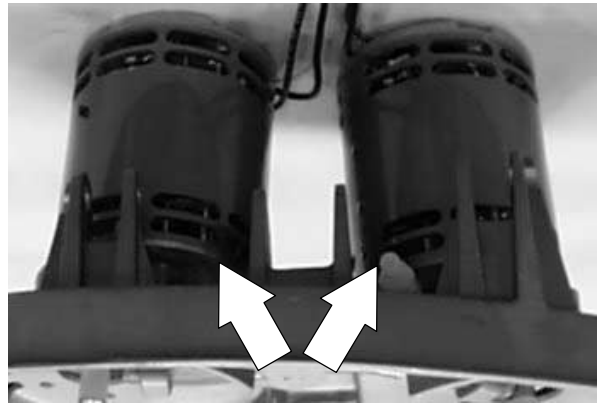

7. Operate the machine. Check the disc scrub brush for proper operation.

ELECTRICAL SCHEMATIC

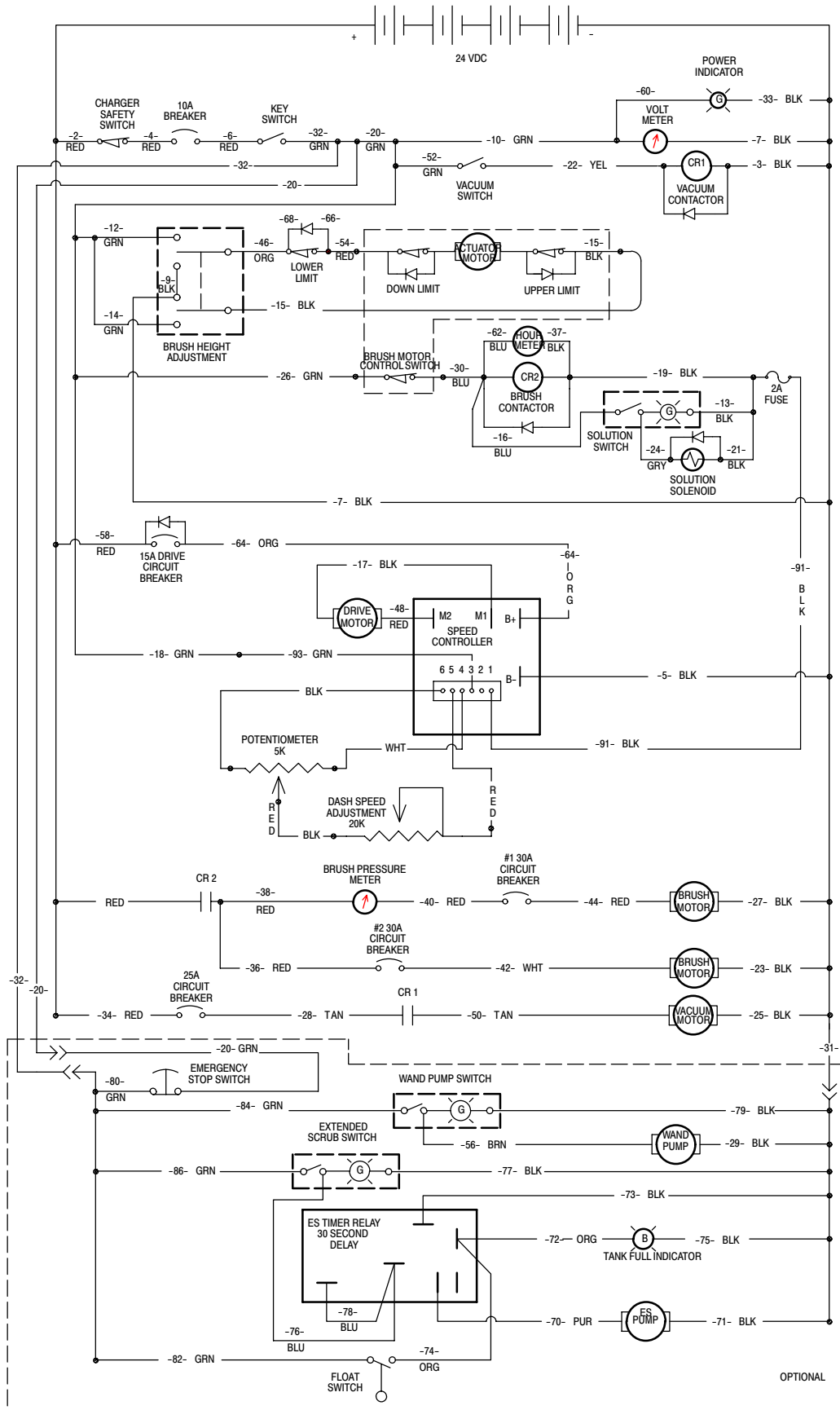

WIRING DIAGRAM (OPTIONS)

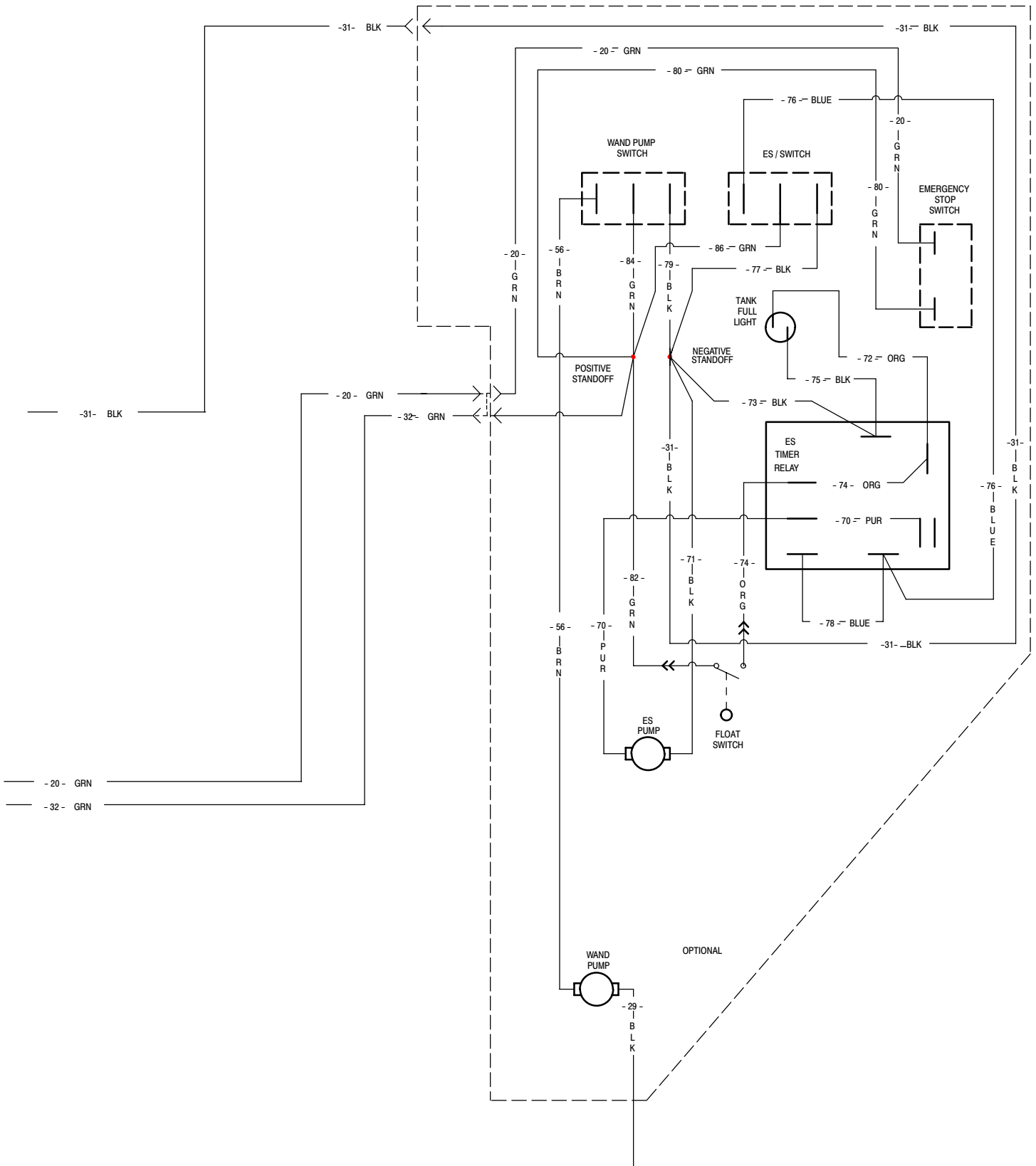

TROUBLESHOOTING

The troubleshooting flow charts and high lighted electrical schematics are used to diagnose and repair electrical problems.

POWER UP
CIRCUIT

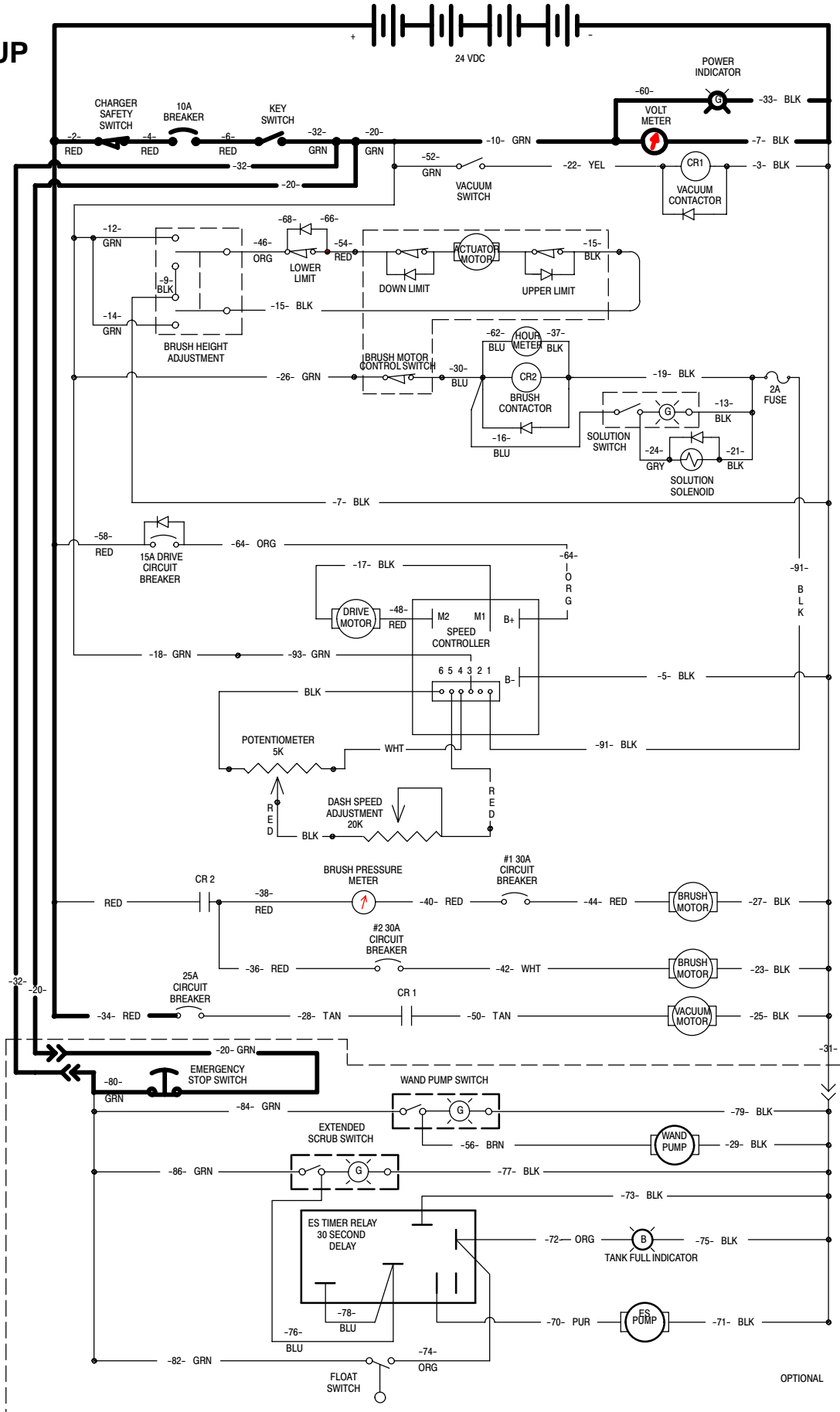

NO POWER (KEY ON AND BATTERY CHARGER DISCONNECTED)

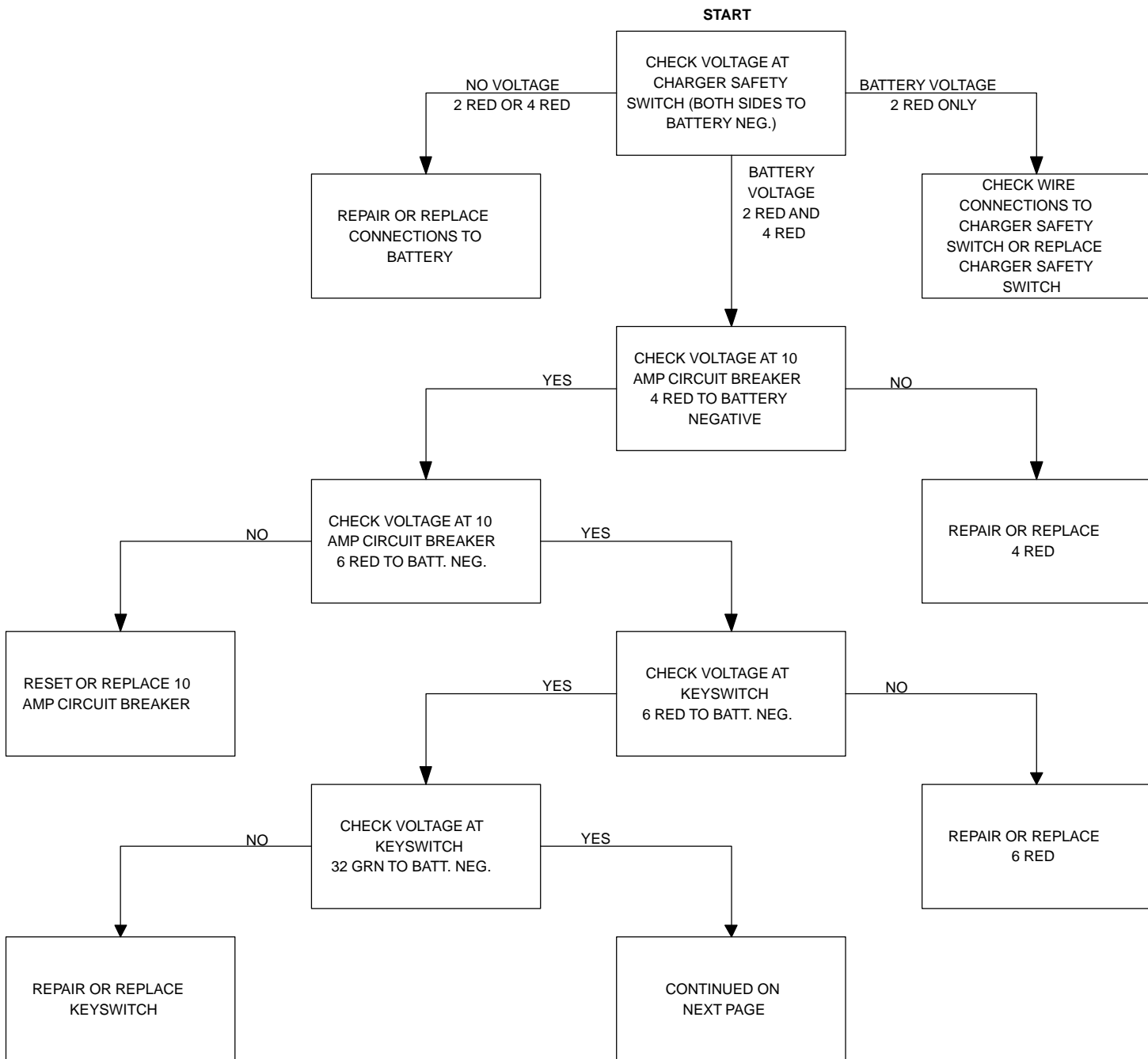

PROPEL
CIRCUIT

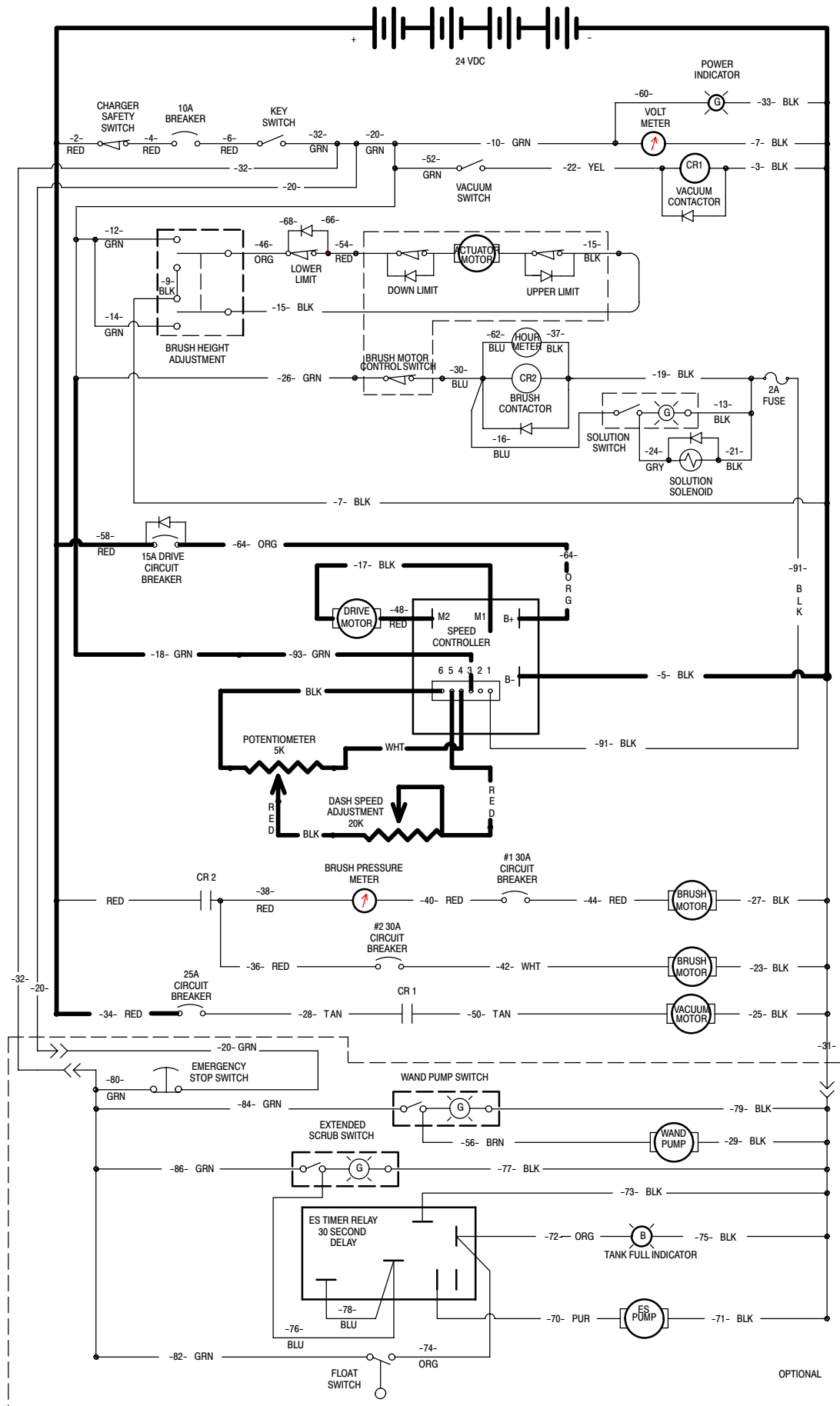

NO PROPEL (POWER UP O.K.)

WHEN TESTING SPEED CONTROL BOARD OUTPUT TWIST ROLL GRIPS FORWARD OR BACKWARD DURING TESTS

START HERE (TURN MACHINE ON)

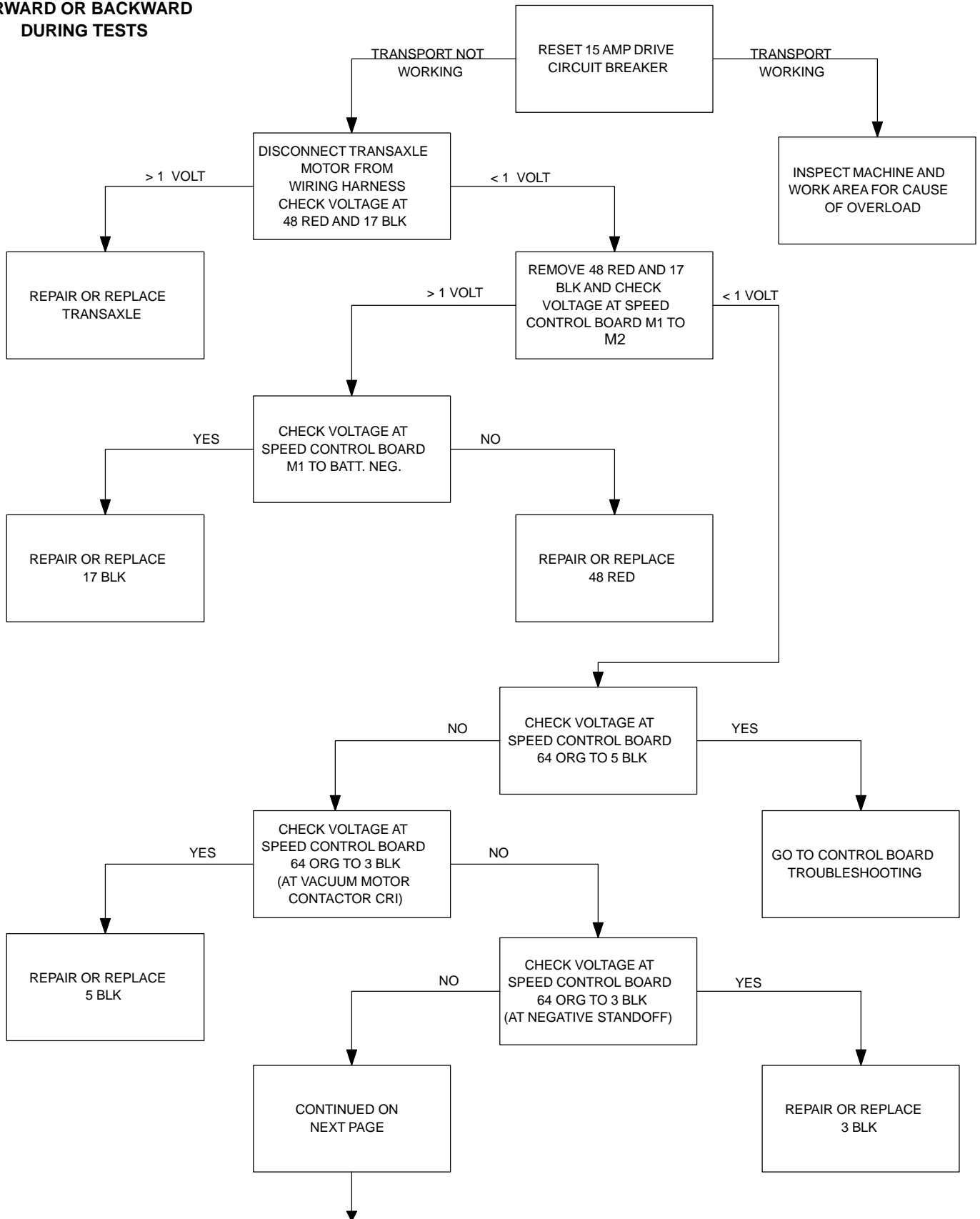

**SAFETY NOTE:
LEAVE TRANSAXLE
DISCONNECTED DURING
TESTS**

NO PROPEL (CONTINUED)

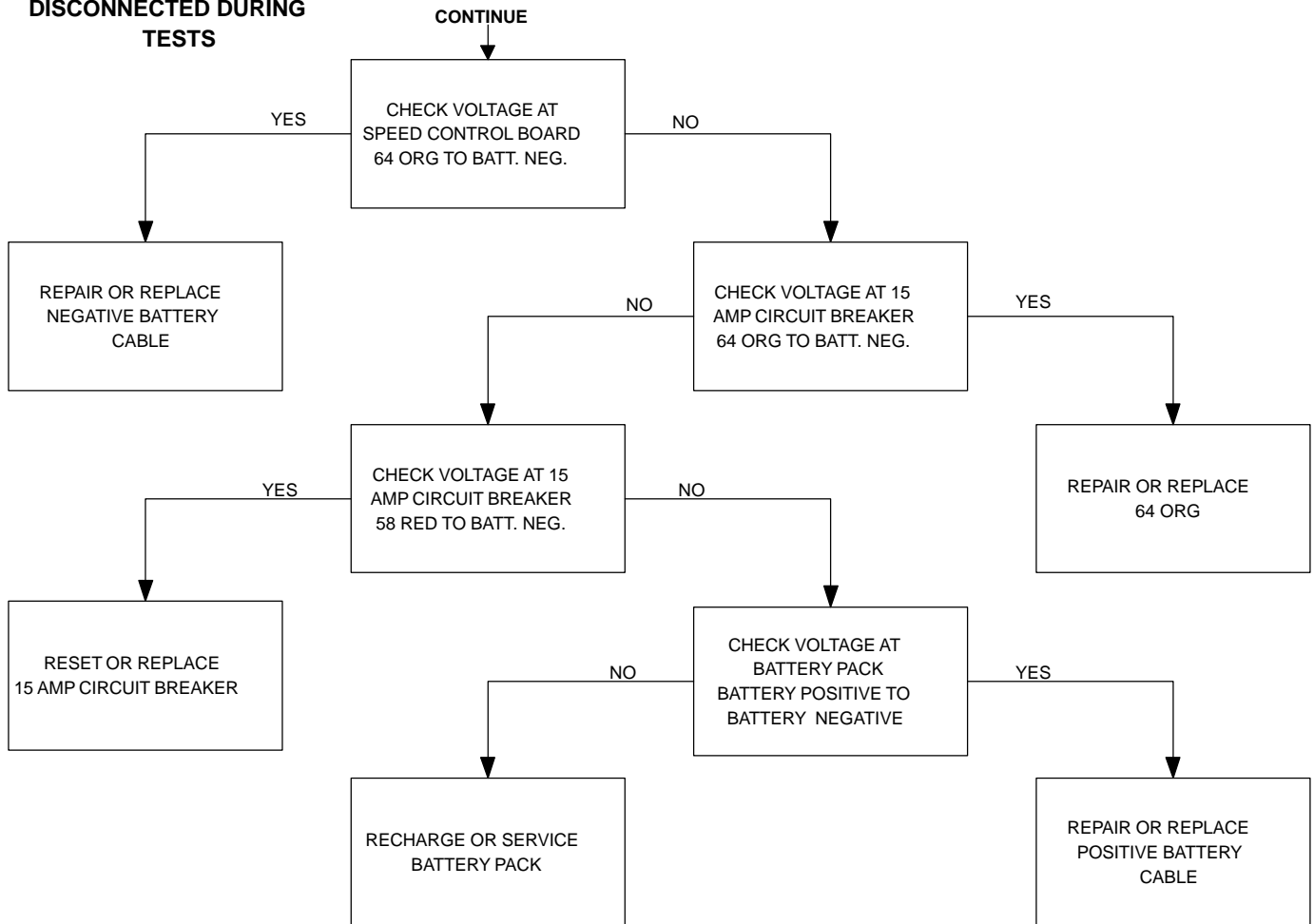

NO PROPEL – CONTROL BOARD TROUBLESHOOTING

CONTINUED FROM PAGE 4-69

**SAFETY NOTE:
LEAVE TRANSAXLE
DISCONNECTED DURING
TESTS**

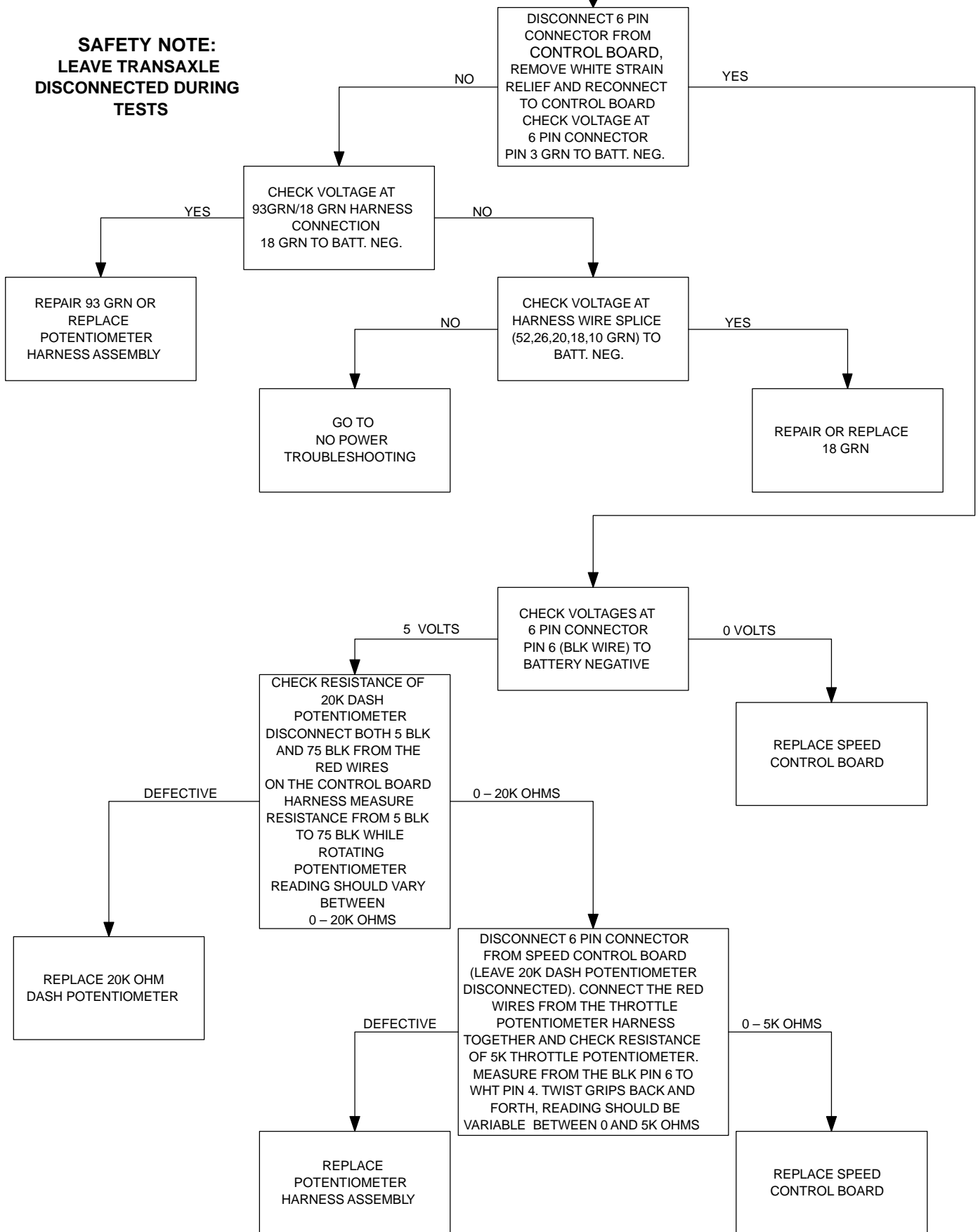

BOTH BRUSHES DO NOT OPERATE WITH BRUSH DECK DOWN

**IF ONE MOTOR WORKS:
GO TO – ONE BRUSH DOES
NOT OPERATE**

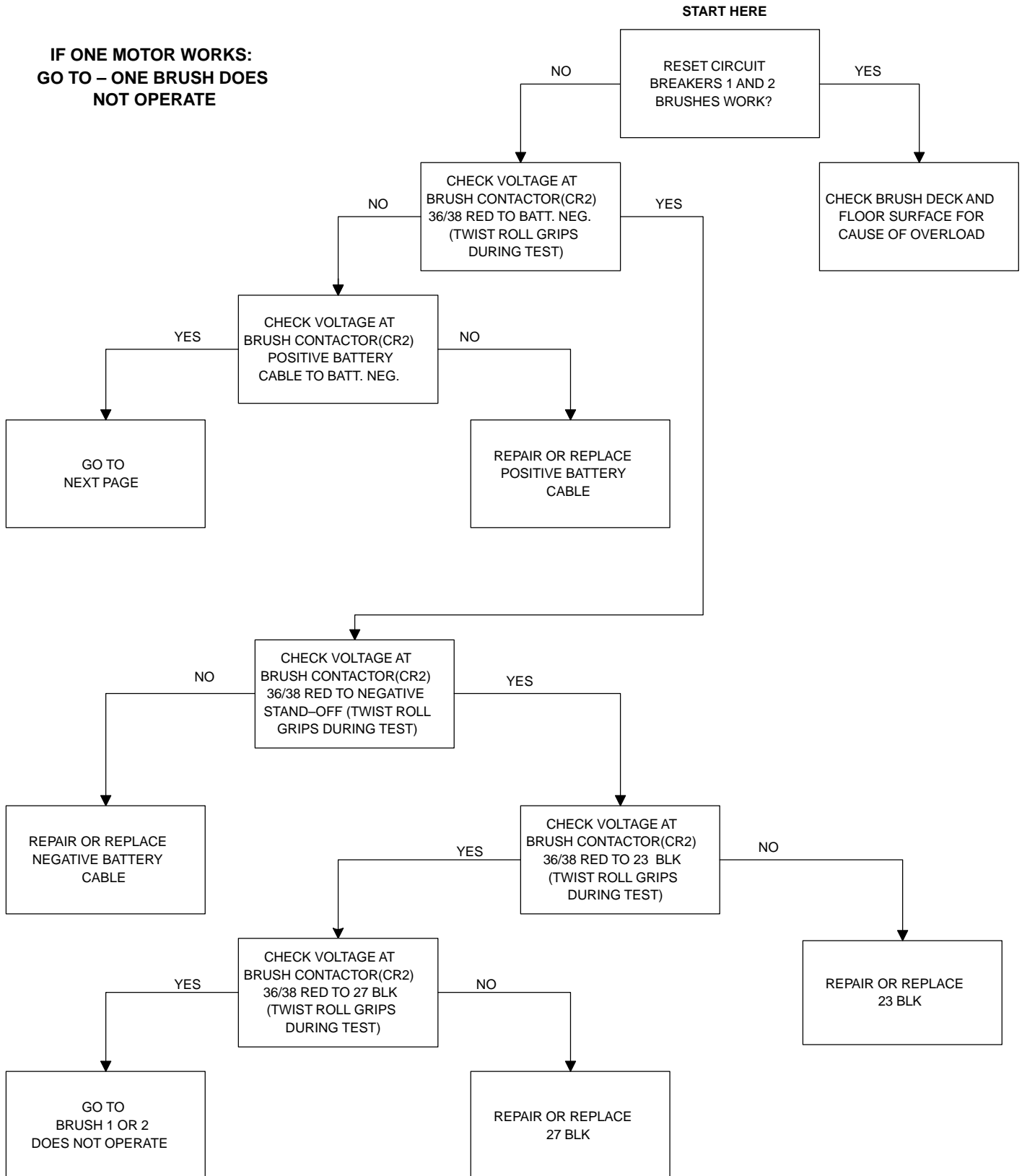

BOTH BRUSHES DO NOT OPERATE (CONTINUED)

CONTINUED FROM PREVIOUS PAGE

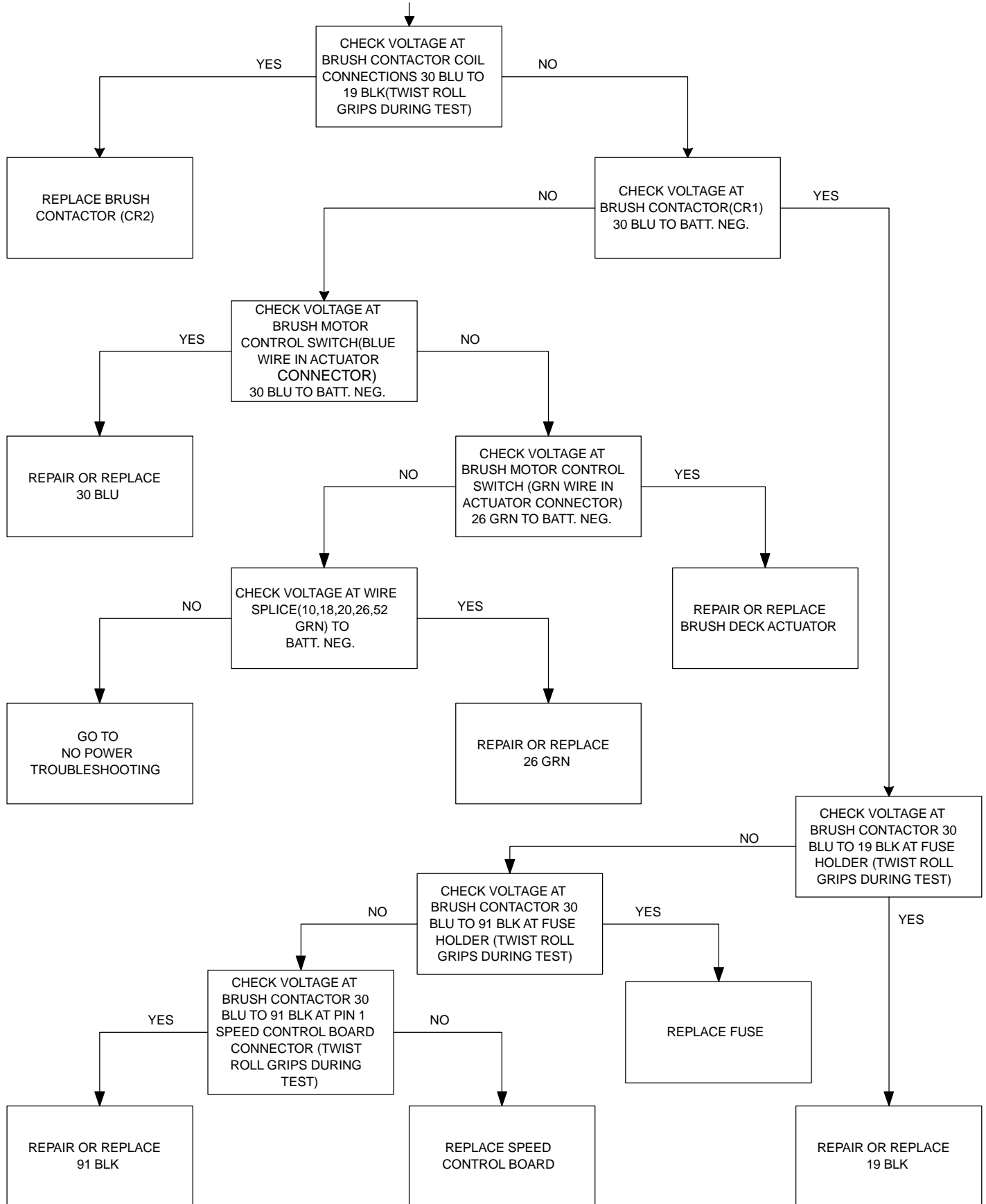

BRUSH MOTOR 1 DOES NOT OPERATE

NOTE: THE TWIST GRIPS MUST BE ROLLED FORWARD OR BACKWARD DURING TESTS

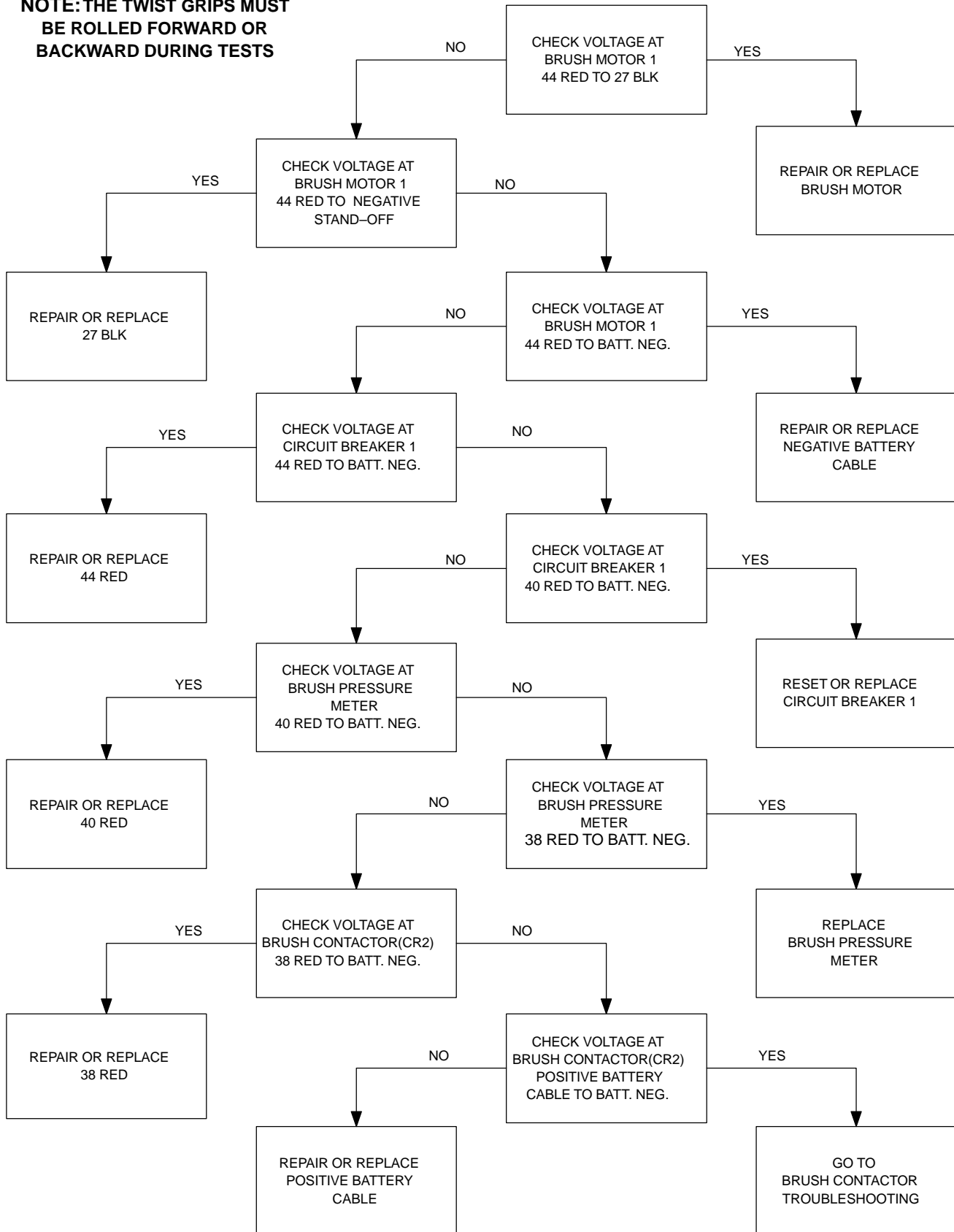

BRUSH MOTOR 2 DOES NOT OPERATE

NOTE: THE TWIST GRIPS MUST BE ROLLED FORWARD OR BACKWARD DURING TESTS

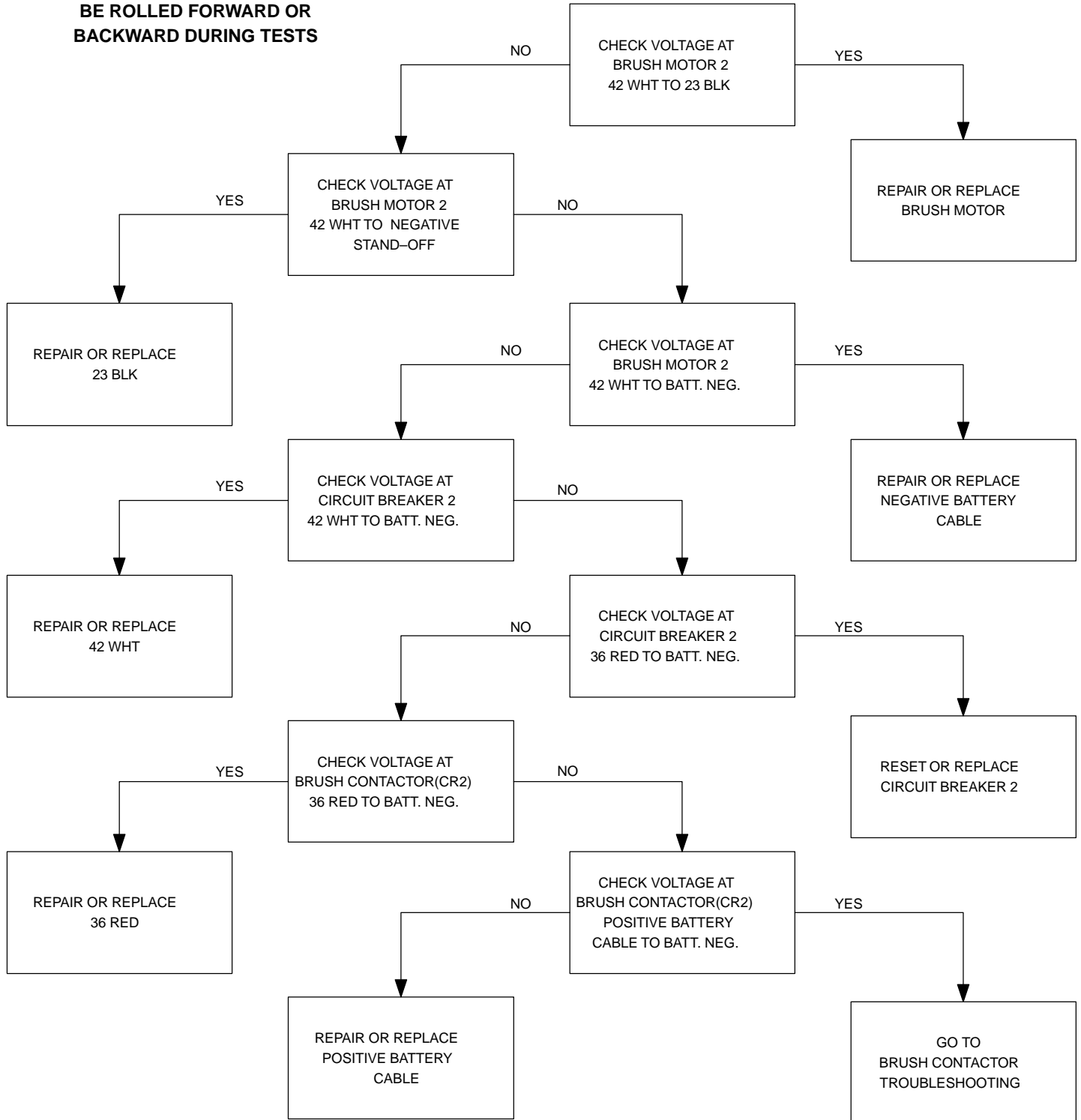

ACTUATOR
CIRCUIT

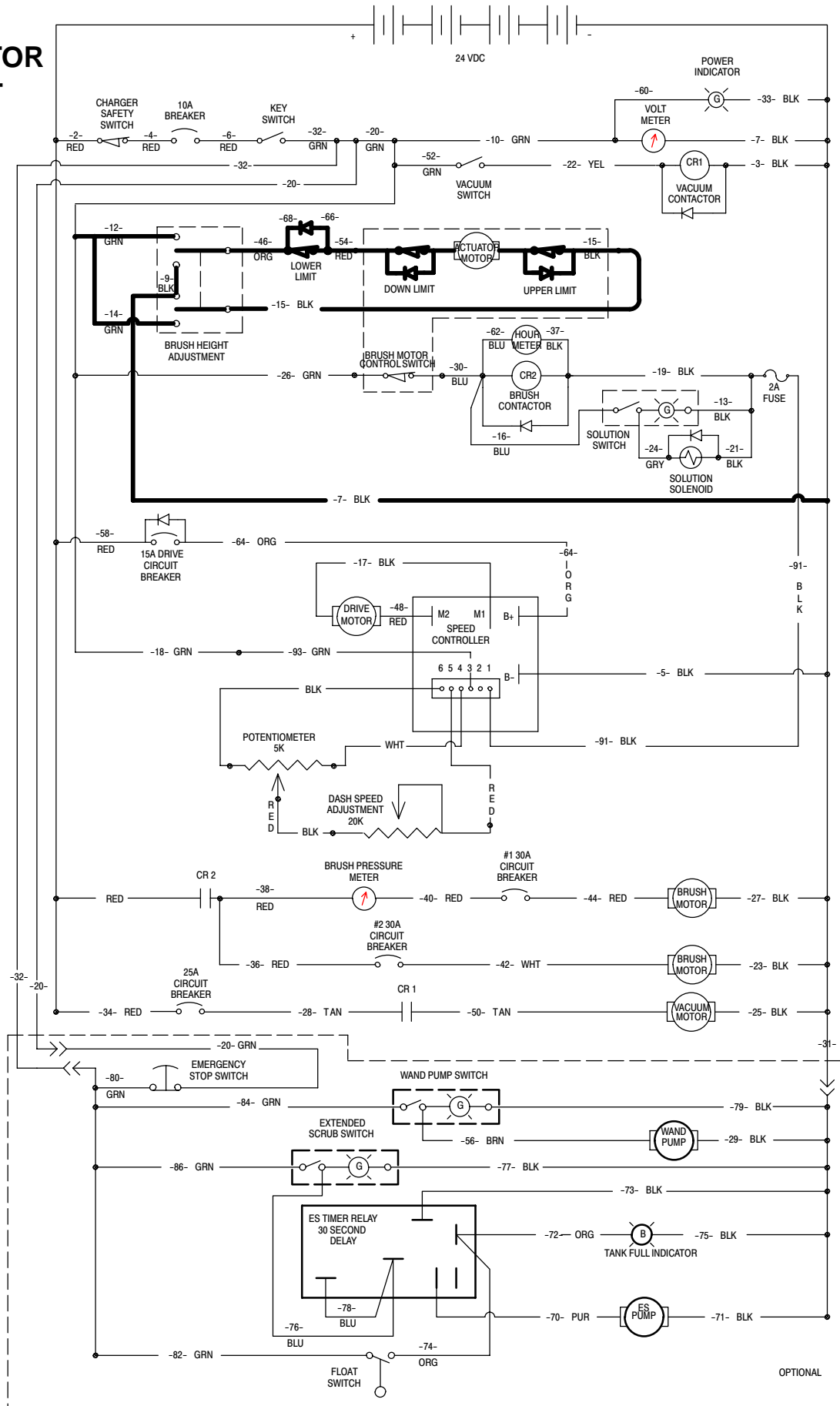

BRUSH DECK WILL NOT LOWER

NOTE: PRESS BRUSH HEIGHT ADJUSTMENT SWITCH DOWN DURING TESTS

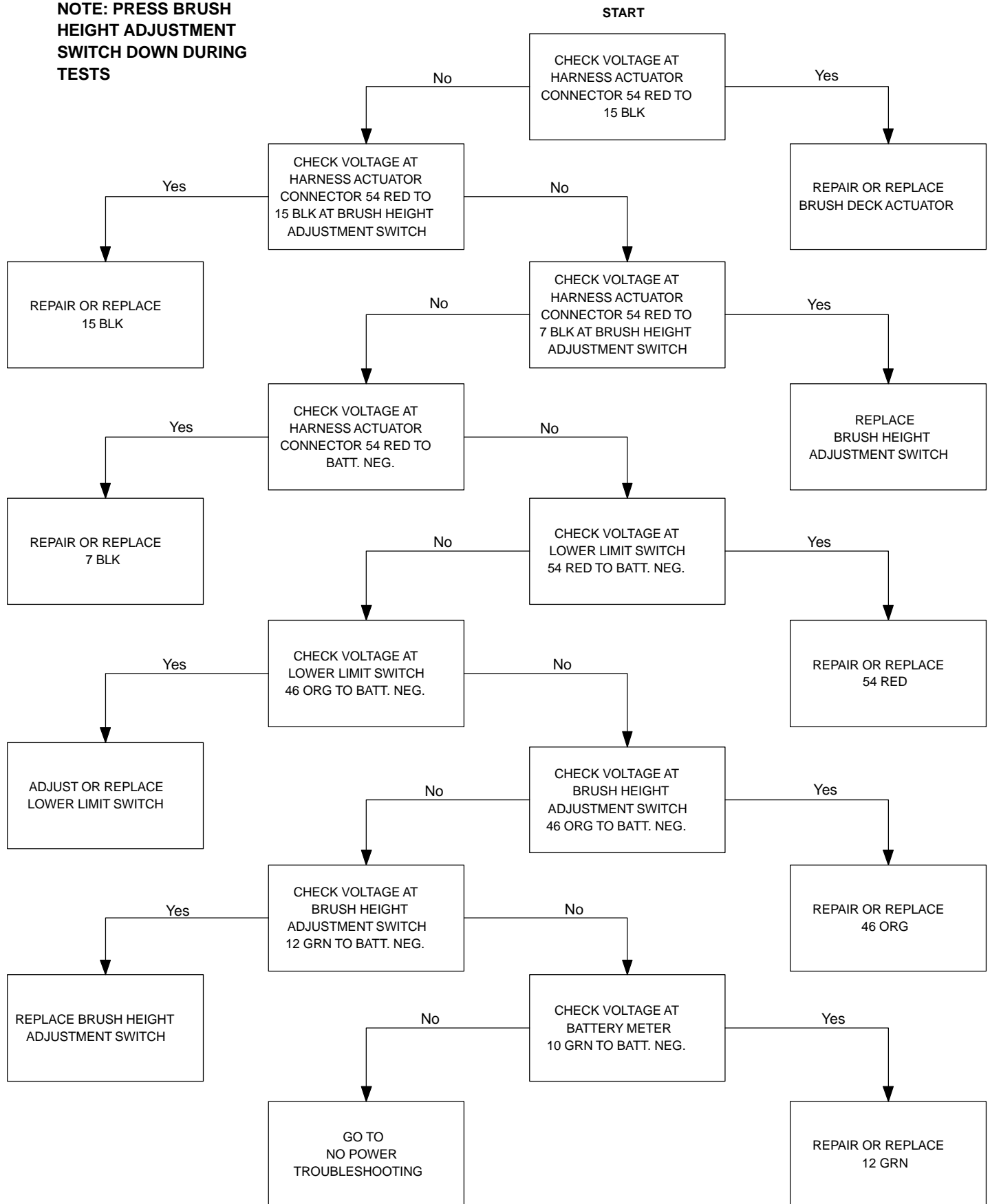

BRUSH DECK WILL NOT RAISE

NOTE: PRESS BRUSH HEIGHT ADJUSTMENT SWITCH UP DURING TESTS

START

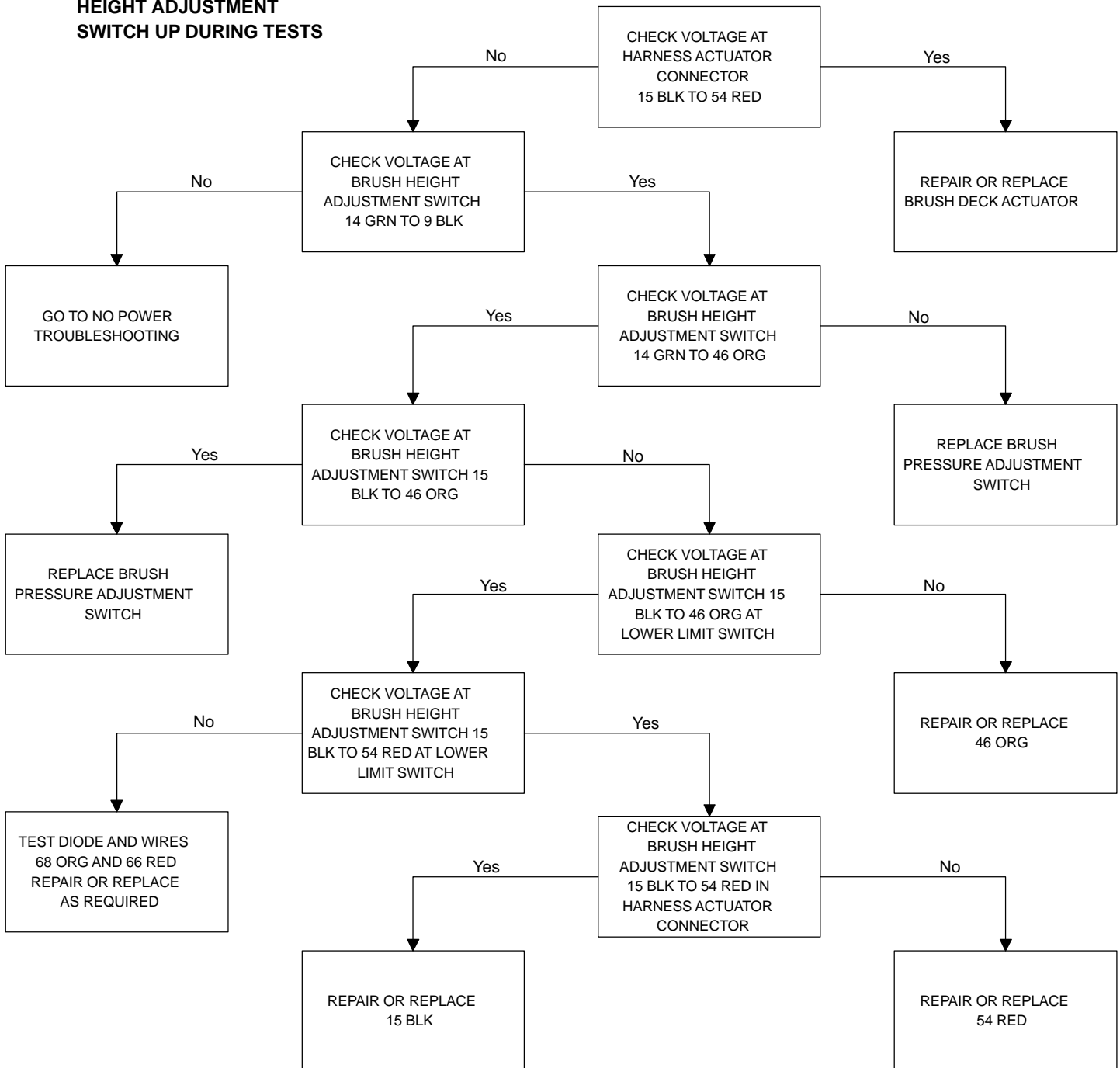

VACUUM FAN CIRCUIT

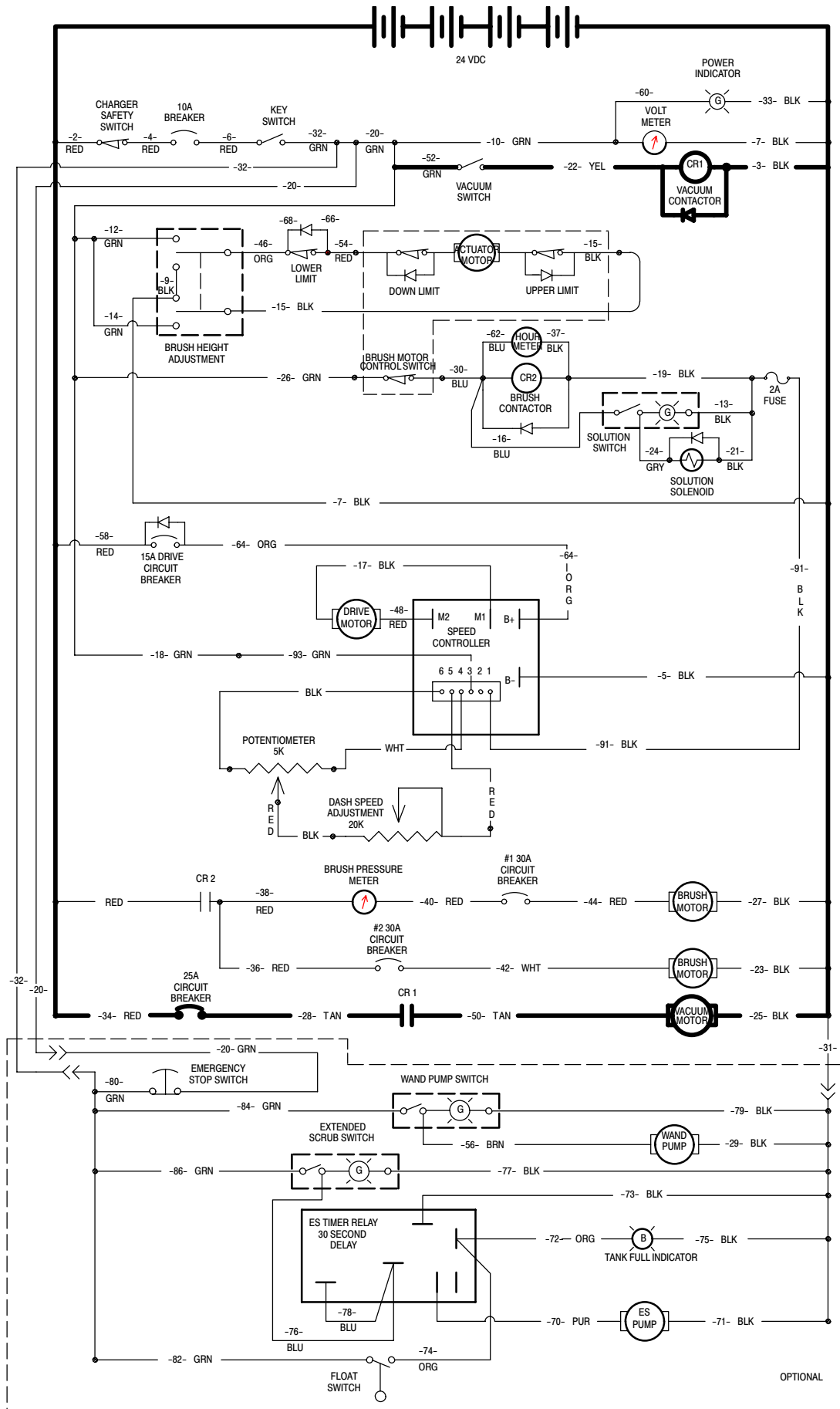

VACUUM FAN DOES NOT OPERATE

NOTE: PERFORM TESTS WITH KEYSWITCH ON AND SQUEEGEE IN DOWN POSITION

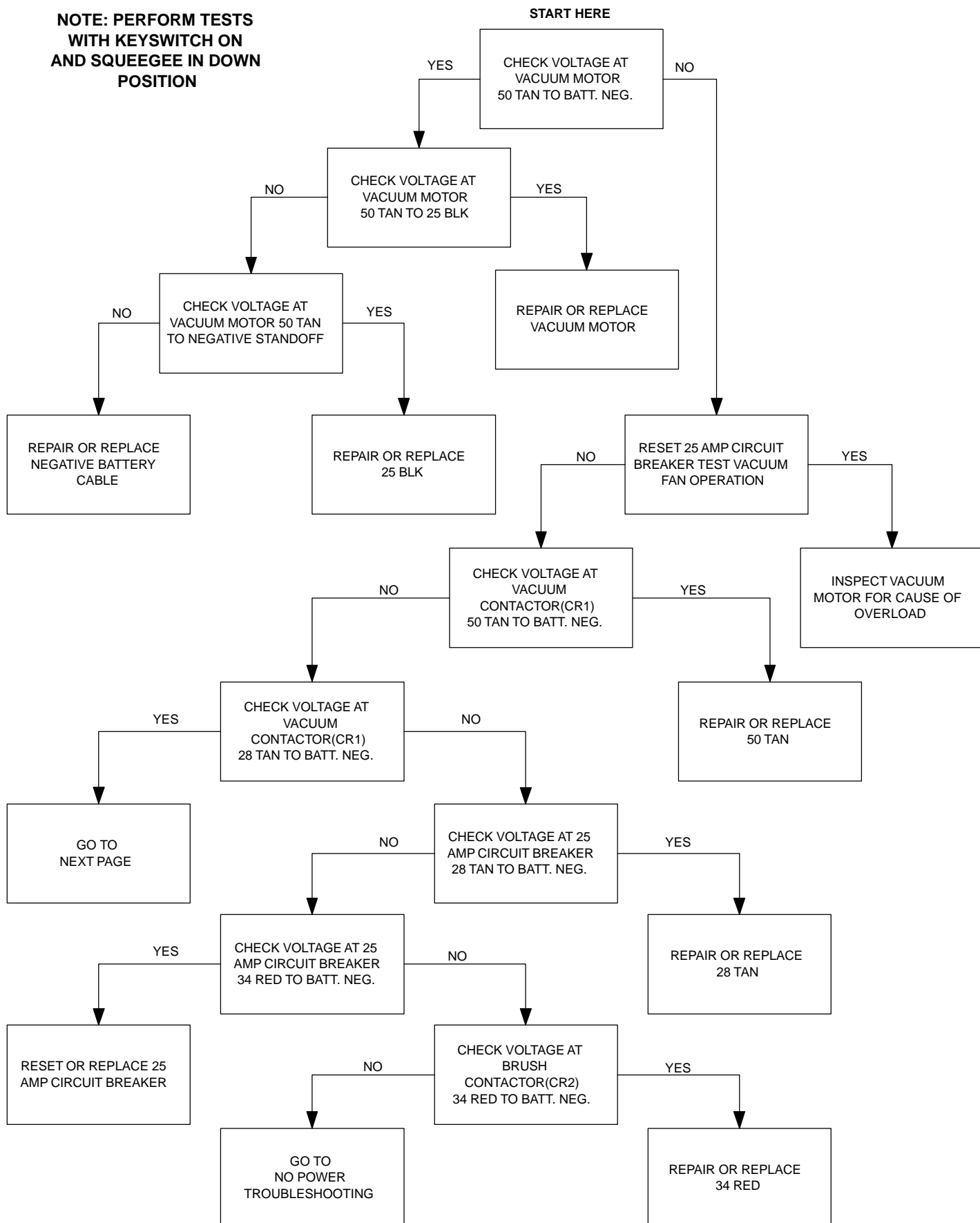

VACUUM FAN DOES NOT OPERATE (CONTINUED)

NOTE: PERFORM TESTS WITH KEYSWITCH ON AND SQUEEGEE IN DOWN POSITION

CONTINUE

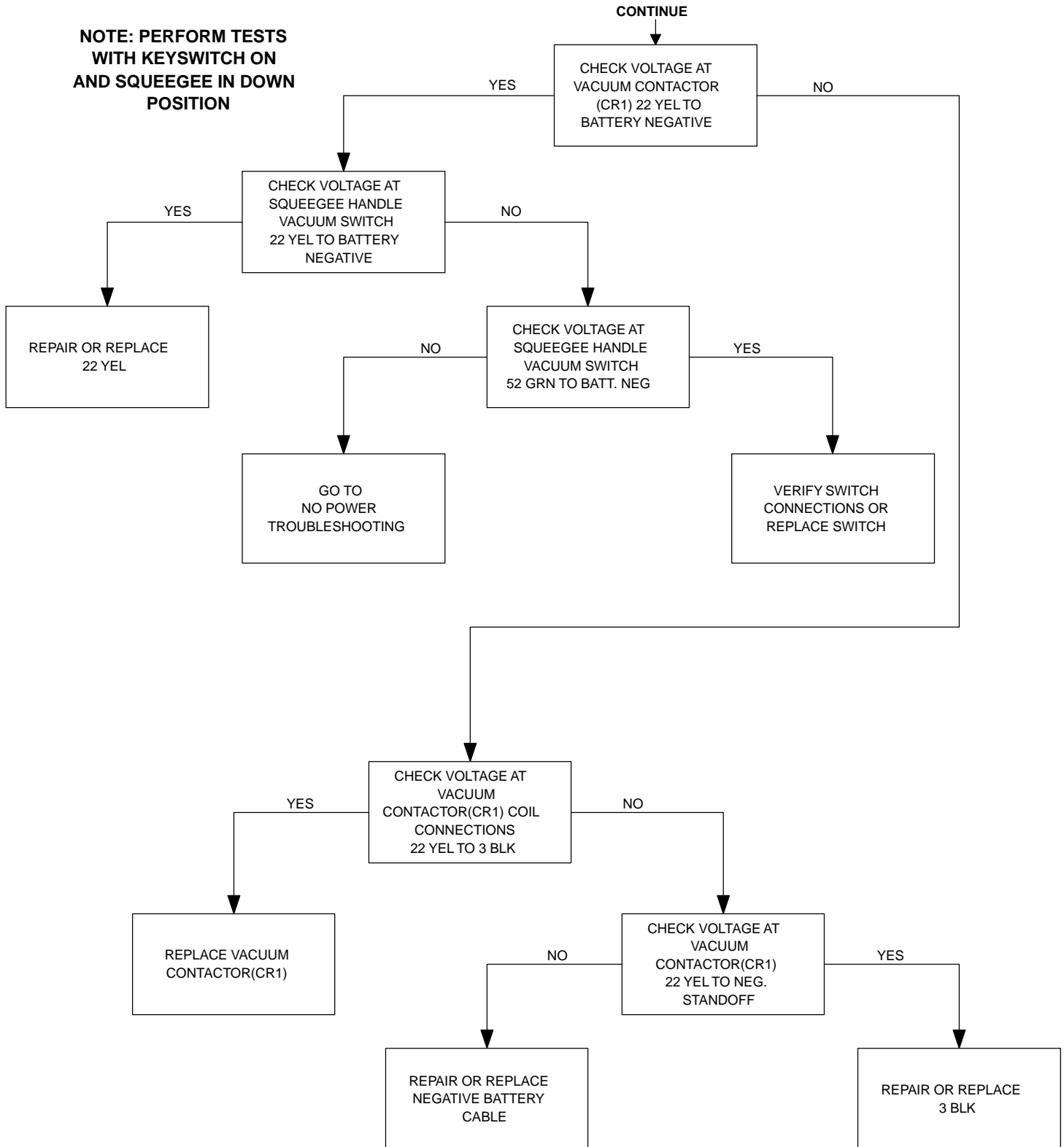

SOLUTION SOLENOID CIRCUIT

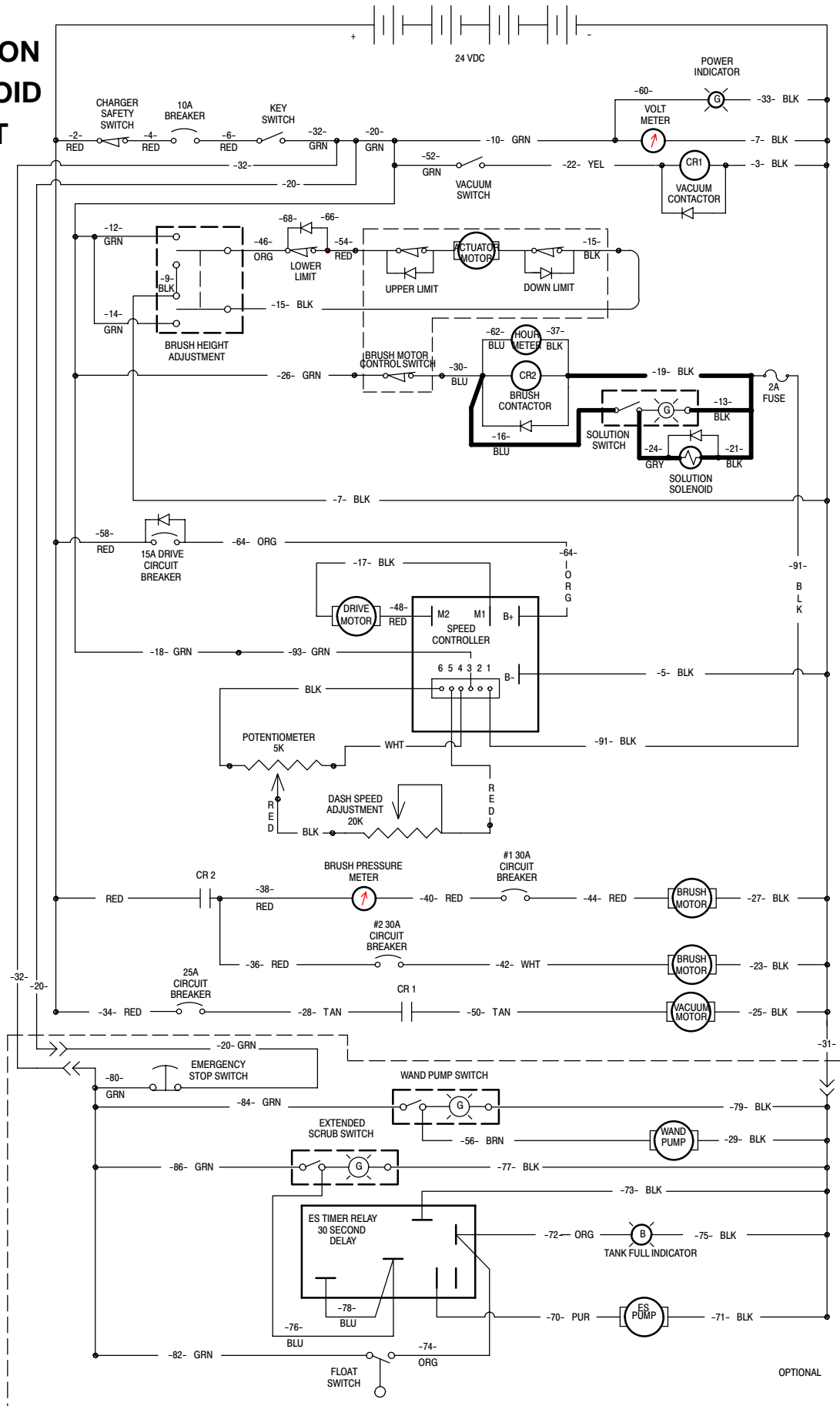

SOLUTION SOLENOID DOES NOT OPERATE (BRUSHES WORK)

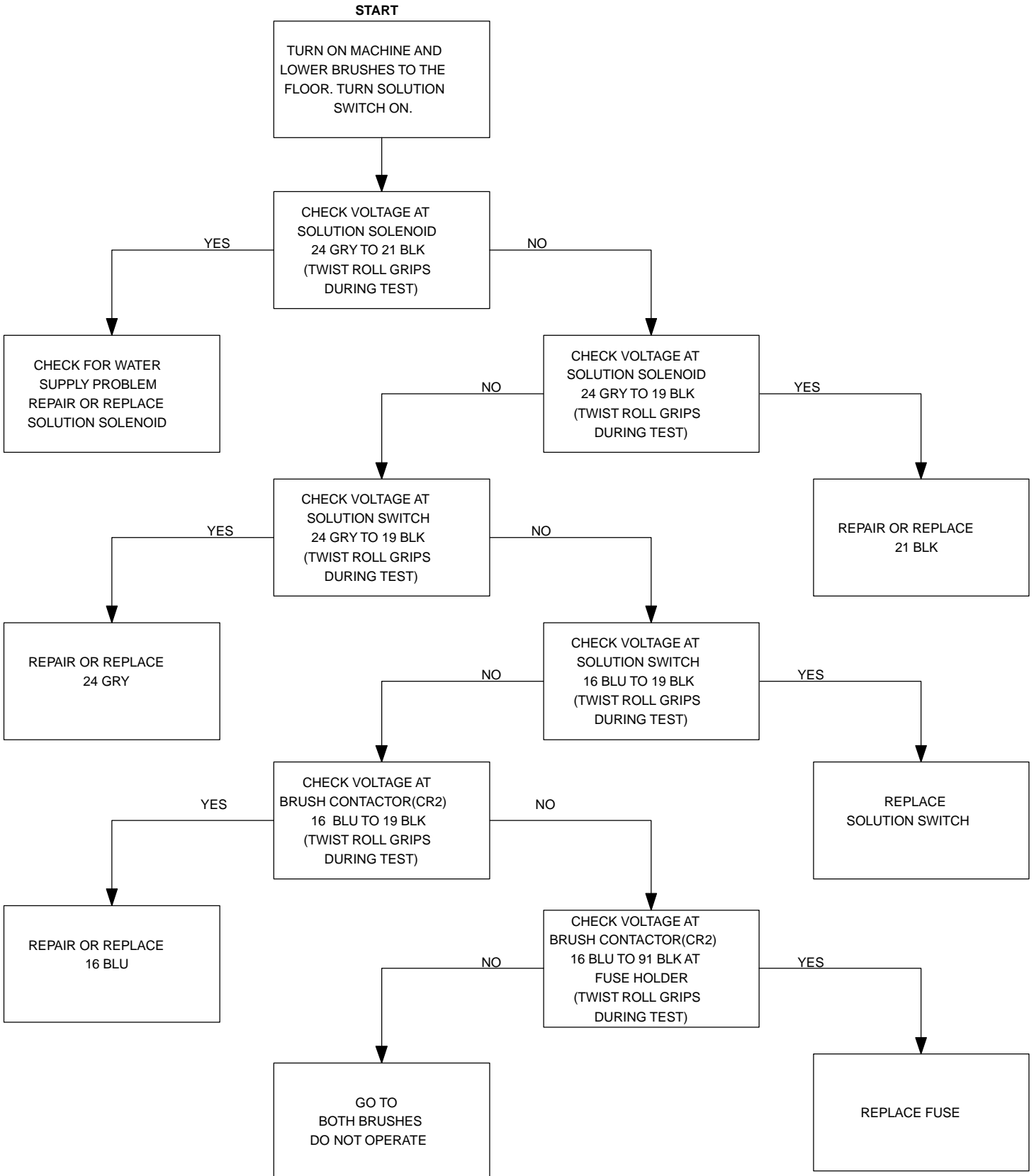

ES™ CIRCUIT

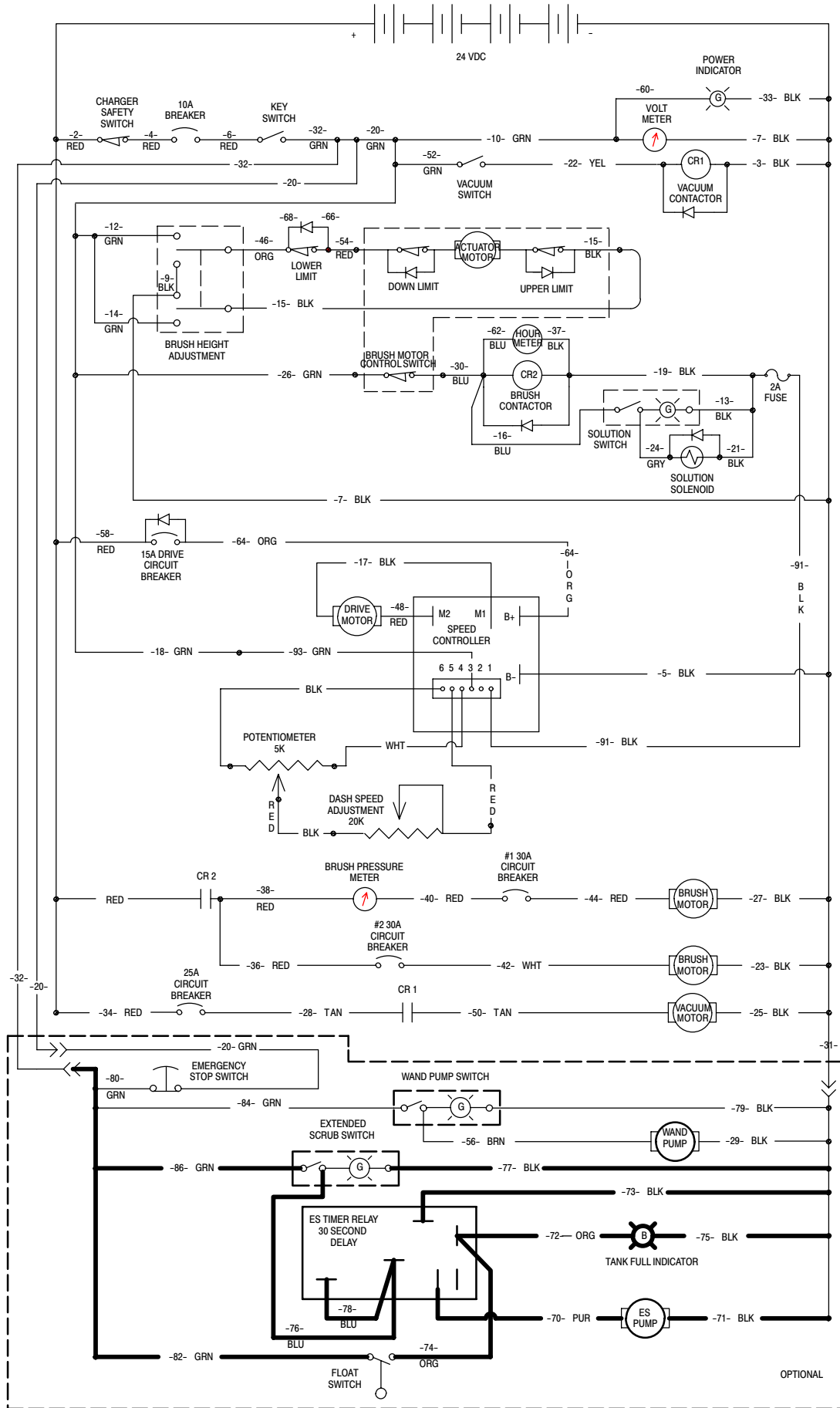

ES™ PUMP DOES NOT OPERATE

NOTE: WATER LEVEL IN RECOVERY TANK MUST BE ABOVE FLOAT SWITCH FOR TESTING

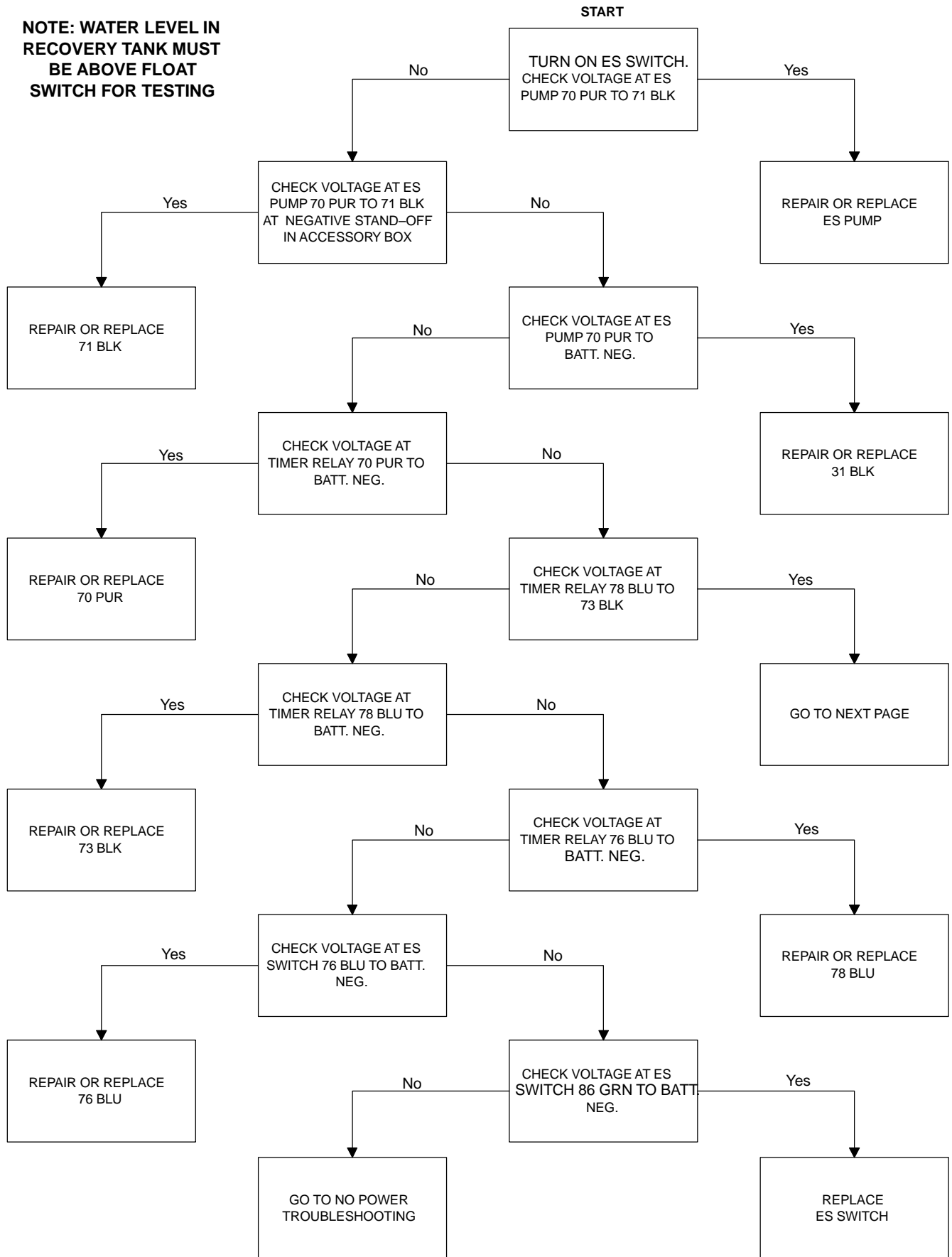

ES™ PUMP DOES NOT OPERATE (CONTINUED)

NOTE: WATER LEVEL IN RECOVERY TANK MUST BE ABOVE FLOAT SWITCH FOR TESTING

CONTINUED FROM PREVIOUS PAGE

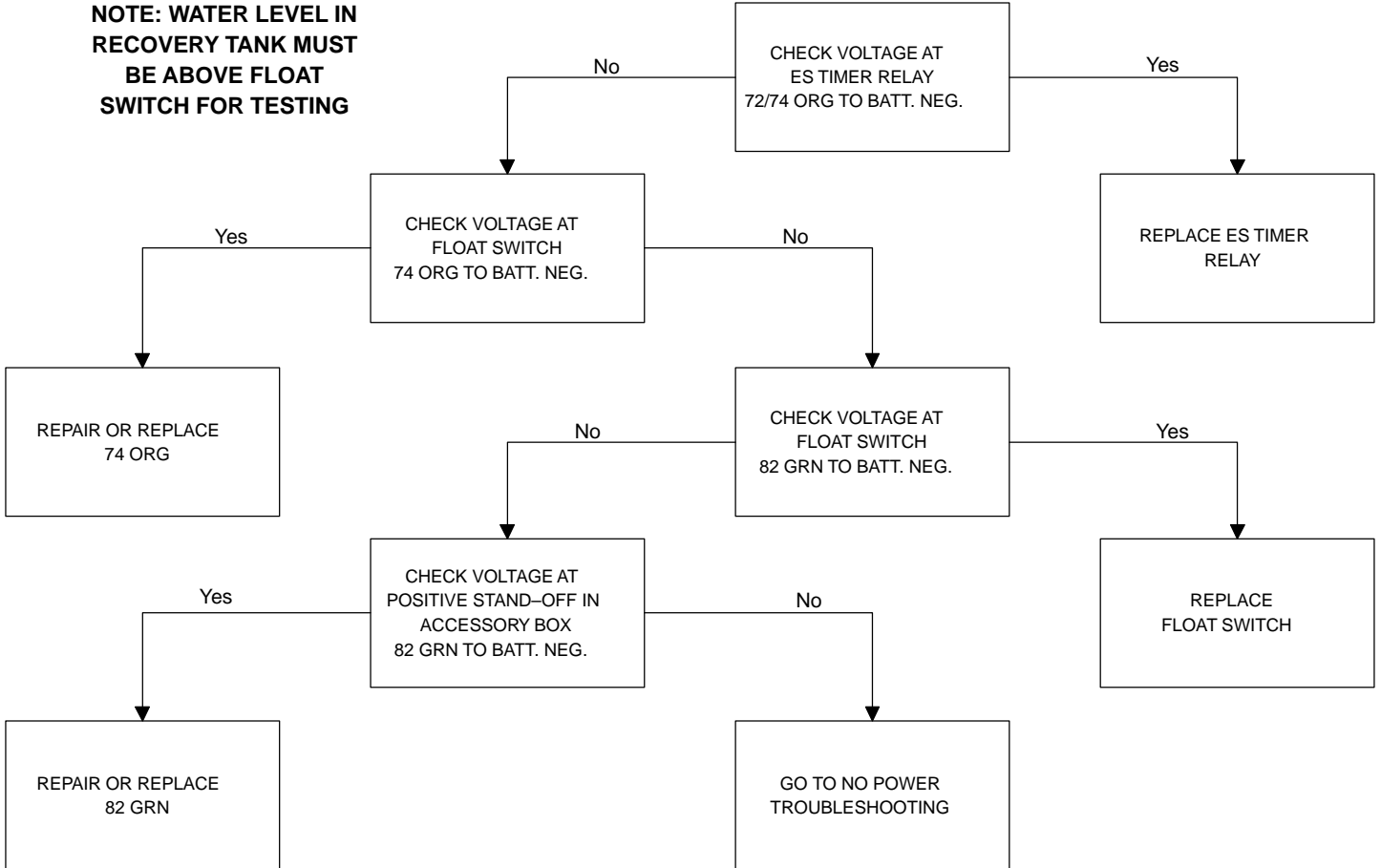

WAND PUMP CIRCUIT

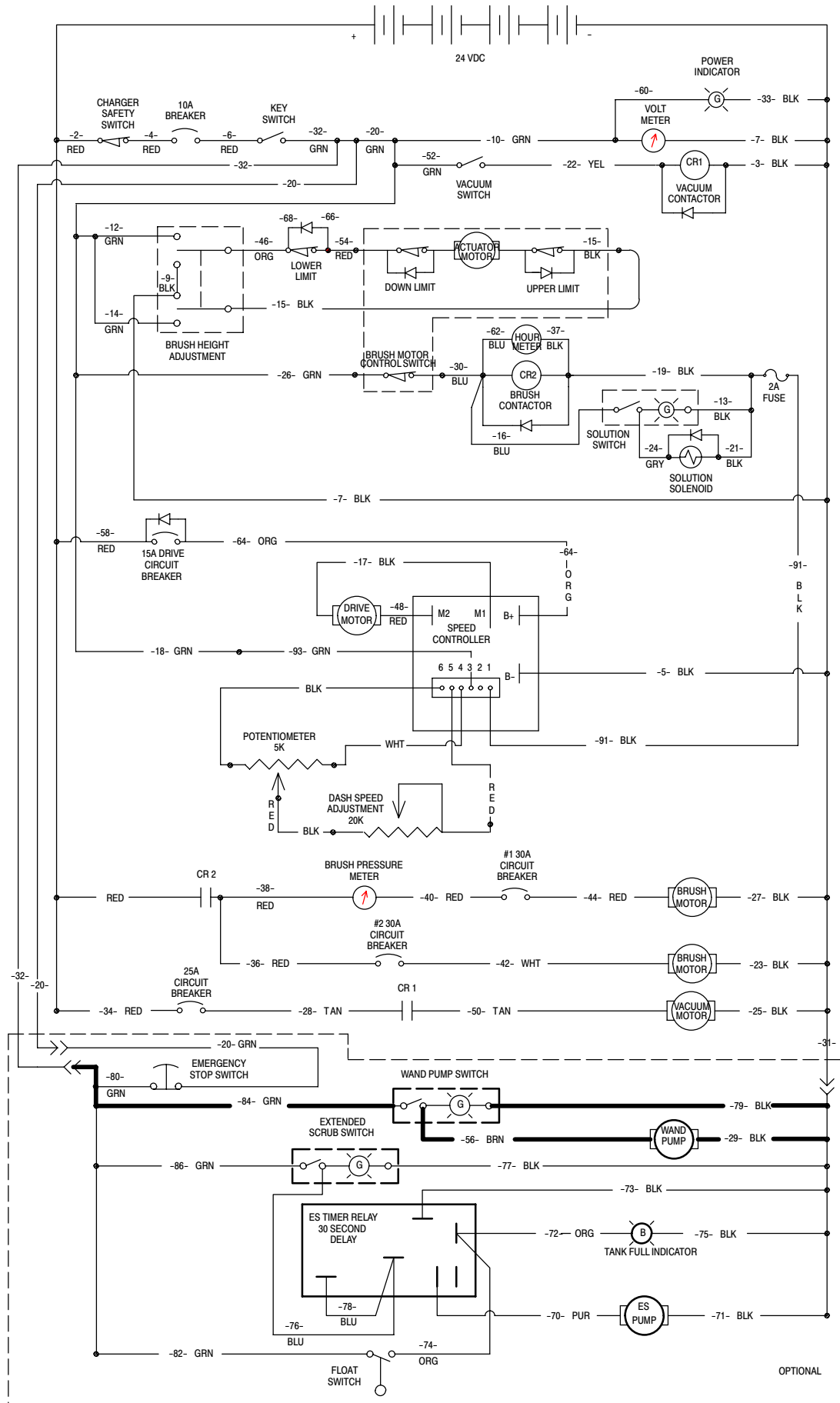

WAND PUMP DOES NOT OPERATE

NOTE: WAND PUMP SWITCH MUST BE ON DURING TESTS

