

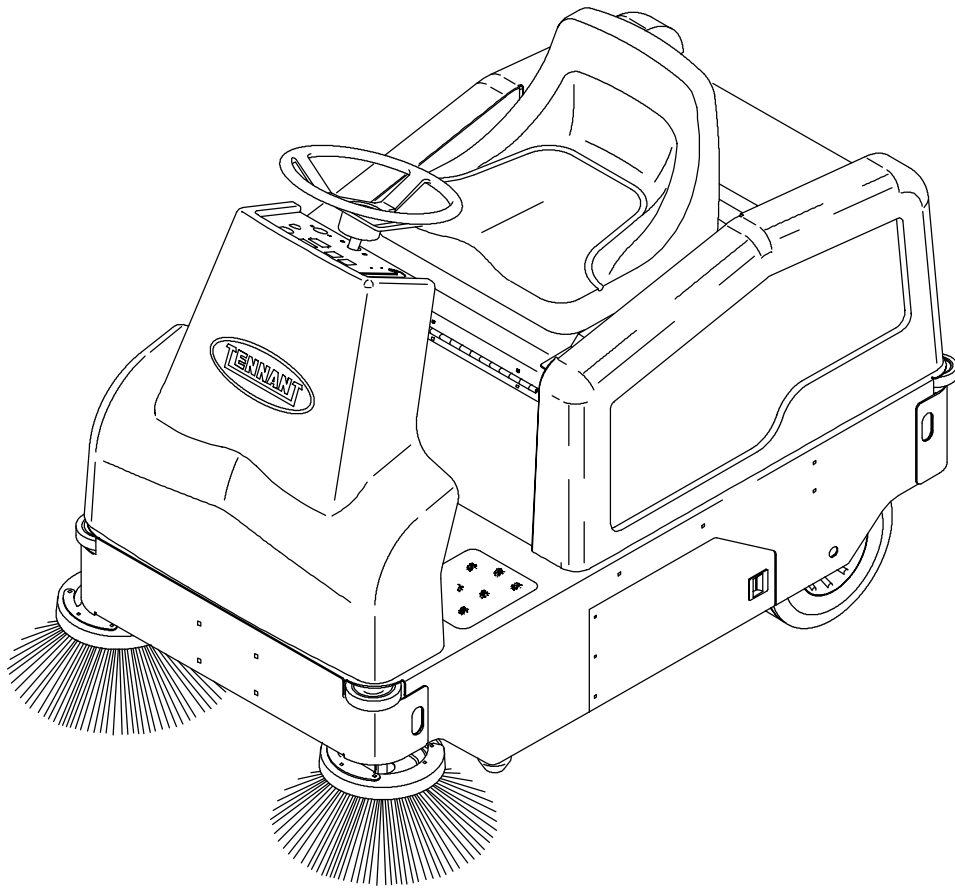

6100E

Service Manual



330255
Rev. 02 (6-01)



This service manual is intended to be used as an aid in the detailed service, repair, and troubleshooting of your TENNANT Model 6100E.

The set is organized into four major groups: General Information, Chassis, Sweeping, and Electrical.

General Information: Safety precautions, machine specifications, machine maintenance chart, machine tieing, machine jacking, machine storing, machine pushing or towing, and hardware information.

Chassis: Tire/wheel replacement, brake adjustment and replacement, steering adjustment and replacement.

Sweeping: Hopper repair/replacement, brush repair/replacement, skirt/seal repair/replacement, and sweeping troubleshooting.

Electrical: Battery maintenance and replacement, motor replacement, electrical schematics, and electrical troubleshooting.

Manual Number - 330255

Revision: 02

Published: 6-01

Copyright © 2000, 2001 TENNANT, Printed in U.S.A.

CONTENTS

	Page
SAFETY PRECAUTIONS	1-3
SPECIFICATIONS	1-5
GENERAL MACHINE	
DIMENSIONS/CAPACITIES	1-5
GENERAL MACHINE PERFORMANCE .	1-5
POWER TYPE	1-6
STEERING	1-6
BRAKING SYSTEM	1-6
TIRES	1-6
MACHINE DIMENSIONS	1-7
MAINTENANCE	1-8
MAINTENANCE CHART	1-8
PUSHING, TOWING, AND	
TRANSPORTING THE MACHINE ..	1-10
PUSHING OR TOWING THE	
MACHINE	1-10
TRANSPORTING THE MACHINE ..	1-10
MACHINE JACKING	1-13
STORING MACHINE	1-13
HARDWARE INFORMATION	1-14
STANDARD BOLT TORQUE	
CHART	1-14
METRIC BOLT TORQUE CHART ..	1-14
BOLT IDENTIFICATION	1-14
THREAD SEALANT AND LOCKING	
COMPOUNDS	1-14

SAFETY PRECAUTIONS

The following symbols are used throughout this manual as indicated in their description:



WARNING: To warn of hazards or unsafe practices that could result in severe personal injury or death.

FOR SAFETY: To identify actions that must be followed for safe operation of equipment.

The machine is suited to sweep disposable debris. Do not use the machine other than described in this Operator Manual. The machine is not designed for use on public roads.

The following information signals potentially dangerous conditions to the operator or equipment:

FOR SAFETY:

1. **Do not operate machine:**
 - Unless trained and authorized.
 - Unless operation manual is read and understood.
 - In flammable or explosive areas unless designed for use in those areas.
 - In areas with possible falling objects unless equipped with overhead guard.
2. **Before starting machine:**
 - Make sure all safety devices are in place and operate properly.
 - Check brakes and steering for proper operation.
3. **When starting machine:**
 - Keep foot on brake and directional pedal in neutral.
4. **When using machine:**
 - Use brakes to stop machine.
 - Go slowly on inclines and slippery surfaces.
 - Use care when reversing machine.
 - Do not carry riders on machine.
 - Always follow safety and traffic rules.
 - Report machine damage or faulty operation immediately.
5. **Before leaving or servicing machine:**
 - Stop on level surface.
 - Set parking brake.
 - Turn off machine and remove key.

6. **When servicing machine:**
 - Avoid moving parts. Do not wear loose jackets, shirts, or sleeves when working on machine.
 - Block machine tires before jacking up machine.
 - Jack up machine at designated locations only. Block machine up with jack stands.
 - Use hoist or jack that will support the weight of the machine.
 - Wear eye and ear protection if using pressurized air or water.
 - Disconnect battery connections before working on machine.
 - Avoid contact with battery acid.
 - Use cardboard to locate leaking hydraulic fluid under pressure.
 - Use Tennant supplied or equivalent replacement parts.

7. **When loading/unloading machine onto/off truck or trailer:**
 - Turn off machine.
 - Use truck or trailer that will support the weight of the machine.
 - Use winch. Do not drive the machine onto/off the truck or trailer unless the load height is 380 mm (15 in) or less from the ground.
 - Set parking brake after machine is loaded.
 - Block machine tires.
 - Tie machine down to truck or trailer.



WARNING: Batteries emit hydrogen gas. Explosion or fire can result. Keep sparks and open flame away. Keep covers open when charging.



WARNING: Brush throws debris. Stop motor before lifting hopper.

GENERAL INFORMATION

The following safety labels are mounted on the machine in the locations indicated. If these or any labels become damaged or illegible, install a new label in its place.

FOR SAFETY LABEL - LOCATED ON THE SIDE OF THE OPERATOR COMPARTMENT.

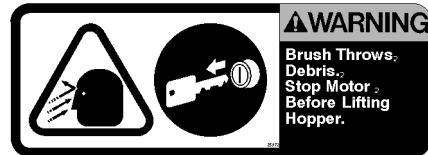
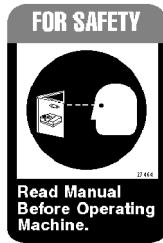

FLYING DEBRIS LABEL - LOCATED ABOVE HOPPER

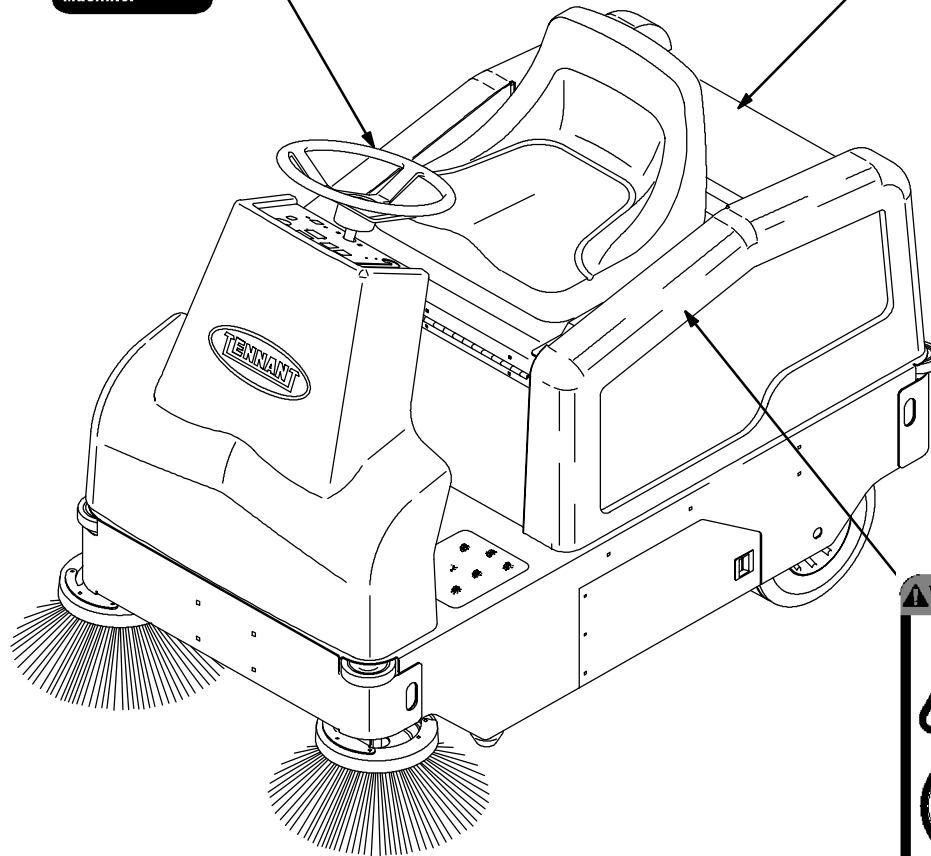

BATTERY CHARGING LABEL - LOCATED IN BATTERY COMPARTMENT.

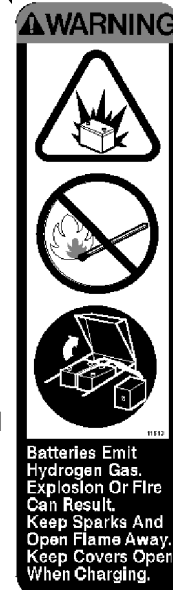

SPECIFICATIONS

GENERAL MACHINE DIMENSIONS/CAPACITIES

Item	Dimension/capacity	
Length	1520 mm	(60 in)
Width	805 mm	(32 in)
Height	1180 mm	(46 in)
Track	880 mm	(35 in)
Wheelbase	682 mm	(27 in)
Main sweeping brush diameter	280 mm	(11 in)
Main sweeping brush length	560 mm	(22 in)
Side brush diameter	406 mm	(16 in)
Sweeping path width	560 mm	(22 in)
Sweeping path width with one side brush	762 mm	(30 in)
Sweeping path width with two side brushes	965 mm	(38 in)
Main sweeping brush pattern width	50 mm	(2 in)
Hopper weight capacity	90 kg	(200 lb)
Hopper volume capacity	85 L	(3 cu ft)
Dust filter area	3.2 sq m	(34 sq ft)
GVWR	2041 kg	(1009 lb)

GENERAL MACHINE PERFORMANCE

Item	Measure	
Maximum forward speed	8.5 km/h	(5.5 mph)
Maximum reverse speed	4.8 km/h	(3 mph)
Minimum turning radius	1725 mm	(68 in)
Maximum rated incline with empty hopper	10°	
Maximum rated incline with full hopper	8°	

GENERAL INFORMATION

POWER TYPE

Type	Quantity	Volts	Ah Rating	Weight
Batteries	6	6	220 @ hr rate	177 kg (390lbs)

Type	Use	VDC	Kw (hp)
Electric Motor	Propelling	36	1.6 (.75 hp)

Type	VDC	A	Hz	Phase	VAC
Charger	36	20	60	1	240

STEERING

Type	Power source	Emergency steering
Front wheel, manual controlled	Manual steering	Manual

BRAKING SYSTEM

Type	Operation
Service brakes	Mechanical disc brake (1), one front wheel, rod actuated
Parking brake	Utilizes service brakes, cable actuated

TIRES

Location	Type	Size
Front (1)	Solid	90 x 305 mm (3.5 in x12 in OD)
Rear (2)	Solid	76 x 305 mm (3 in x 12 in OD)

GENERAL INFORMATION

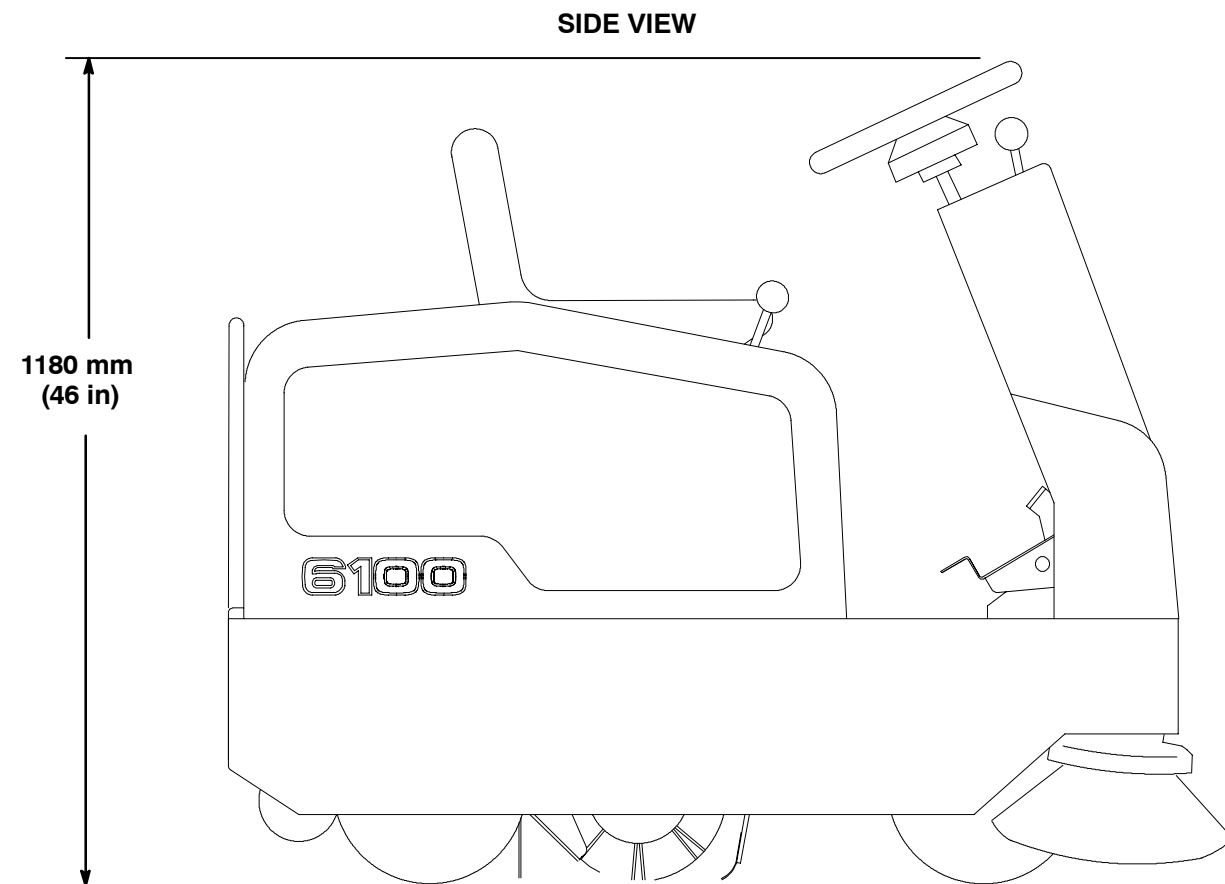
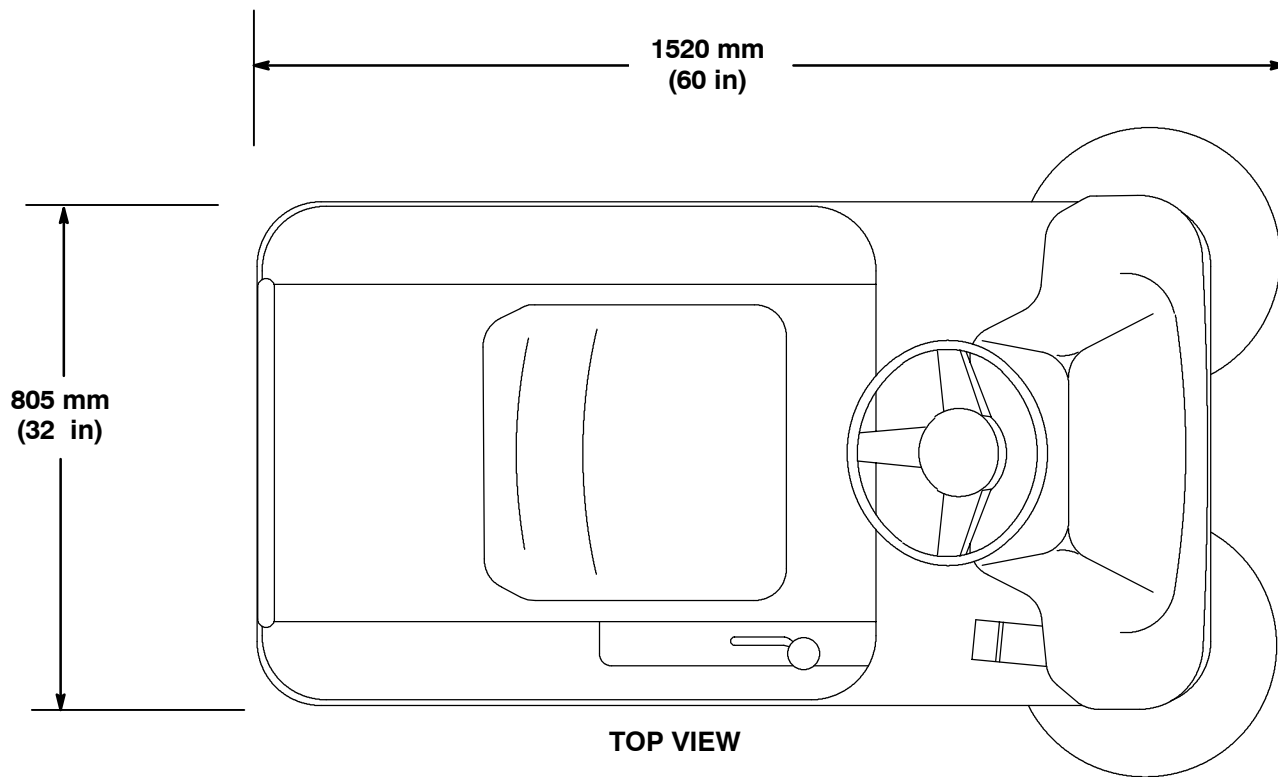

MAINTENANCE

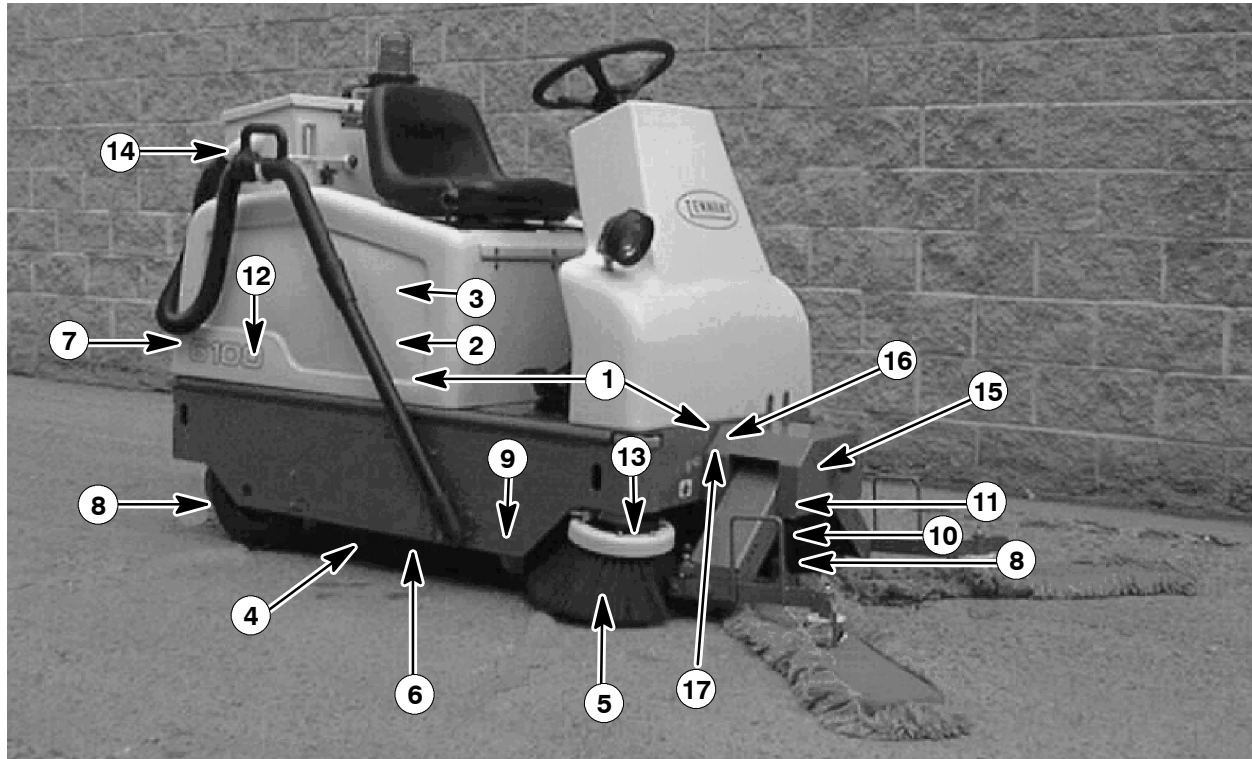

MAINTENANCE CHART

Interval	Key	Description	Procedure	Lubricant/ Fluid	No. of Service Points
Daily	6	Brush compartment skirts	Check for damage, wear, and adjustment	-	6
	4	Main brush	Check for damage or wear	-	1
	5	Side brush(es)	Check for damage or wear	-	1 (2)
			Check brush pattern	-	1 (2)
	7	Hopper dust filter	Shake	-	1
50 Hours	3	Batteries	Check and charge batteries	-	6 (3)
	4	Main brush	Rotate end-for-end	-	1
			Check brush pattern	-	1
	3	Batteries	Check electrolyte level	DW	6 (3)
	14	Vacuum wand bag (Option)	Check or change vacuum bag	-	-
		Vacuum wand fan(s) (Option)	Check for damage or wear	-	2
15	QuickMop™ broom (Option)	Rotate or wash sweep heads	-	2	

GENERAL INFORMATION

Interval	Key	Description	Procedure	Lubricant/ Fluid	No. of Service Points
100 Hours	7	Hopper dust filter	Check for damage, clean or replace	-	1
	8	Tires	Check for damage or wear	-	3
	9	Large Debris Trap Flap	Check for damage or wear	-	1
	10	Propelling chain	Lubricate and check tension	EO	1
	12	Hopper Seal	Check for damage or wear	-	4
	17	Steering castor pivot bearing	Lubricate and check for wear	SPL	1
200 Hours	11	Brake	Check adjustment	-	1
	13	Side brush(es)	Check pivot adjustment	-	1 (2)
	2	Vacuum fan belt	Check tension and wear	-	1
	3	Main brush belt	Check for wear	-	1
	16	Steering gear chain	Lubricate	EO	1
800 Hours	1	Electric motors	Check carbon brushes	-	3

LUBRICANT/FLUID

DW Distilled water

EO SAE 30 Engine oil

SPL . . . Special lubricant, Lubriplate EMB grease (TENNANT part no. 01433-1)

NOTE: More frequent intervals may be required in extremely dusty conditions.

PUSHING, TOWING, AND TRANSPORTING THE MACHINE

PUSHING OR TOWING THE MACHINE

If the machine becomes disabled, it can be pushed or towed from the front or rear, but it is easier and more stable to tow from the front end.

Unplug the drive motor from the electrical harness before attempting to push the machine. The machine will become easier to maneuver when it is unplugged.

ATTENTION! Do not push or tow the machine for a long distance and without unplugging the drive motor or damage may occur to the propelling system.

Only push or tow the machine for a *very short distance* and do not exceed 3.2 kp/h (2 mph). It is NOT intended to be pushed or towed for a long distance or at a high speed.

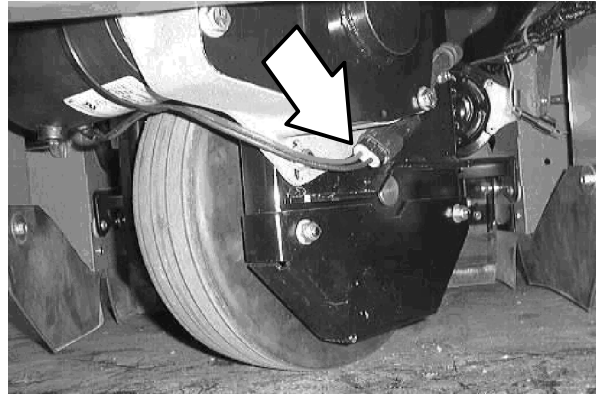

TRANSPORTING THE MACHINE

1. Position the front of the machine at the loading edge of the truck or trailer.

FOR SAFETY: Use truck or trailer that will support the weight of the machine.

NOTE: Empty the hopper before transporting the machine.

2. If the loading surface is not horizontal or is higher than 380 mm (15 in) from the ground, use a winch to load machine.

If the loading surface is horizontal AND is 380 mm (15 in) or less from the ground, the machine may be driven onto the truck or trailer.

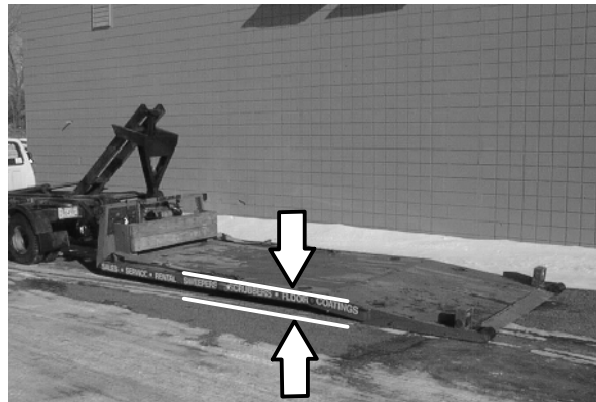

3. To winch the machine onto the truck or trailer, attach the winching chains to the front tie down located in the front of the machine frame.

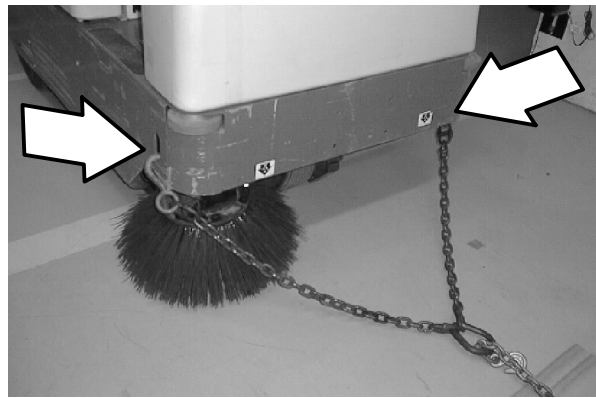

4. Unplug the drive motor from the electrical harness before winching the machine onto the truck or trailer. See *PUSHING OR TOWING THE MACHINE* section of this manual. Make sure the machine is centered.

FOR SAFETY: When loading machine onto truck or trailer, use winch. Do not drive the machine onto the truck or trailer unless the loading surface is horizontal AND is 380 mm (15 in) or less from the ground.

5. Position the machine onto the truck or trailer as far as possible. If the machine starts to veer off the centerline of the truck or trailer, stop and turn the steering wheel to center the machine.

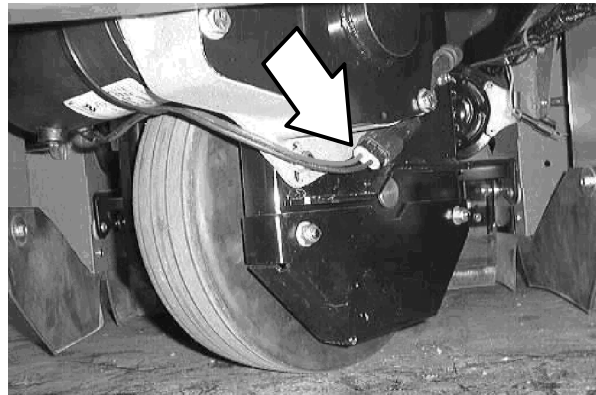

GENERAL INFORMATION

6. Set the parking brake and block the machine tires. Tie down the machine to the truck or trailer before transporting.

The front tie-down locations are the holes in the front of the machine frame.

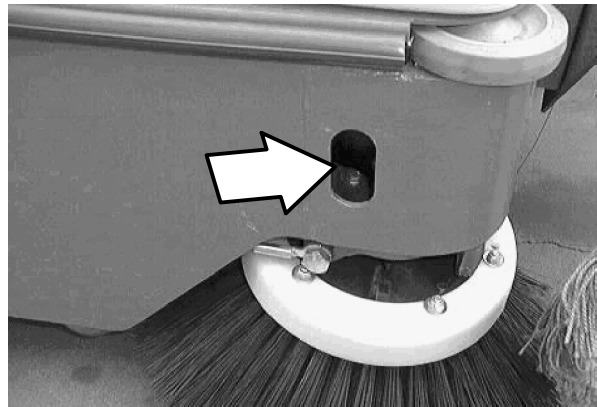

The rear tie-down locations are the holes in the sides of the machine frame near the rear bumper.

7. If the loading surface is not horizontal or is higher than 380 mm (15 in) from the ground, use a winch to unload machine.

If the loading surface is horizontal AND is 380 mm (15 in) or less from the ground, the machine may be driven off the truck or trailer.

FOR SAFETY: When unloading machine off truck or trailer, use winch. Do not drive the machine off the truck or trailer unless the loading surface is horizontal AND 380 mm (15 in) or less from the ground.

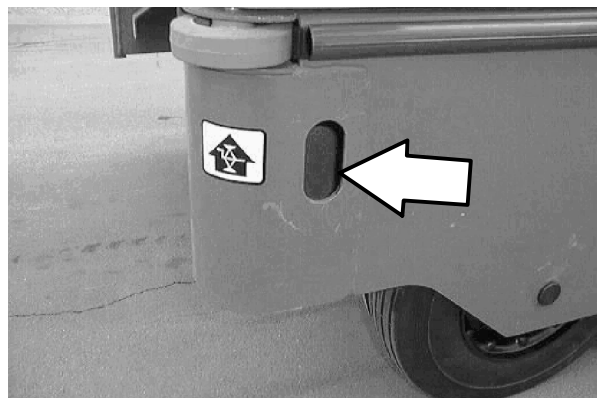

MACHINE JACKING

Empty the hopper before jacking the machine. You can jack up the machine for service at the designated locations. Use a hoist or jack that will support the weight the machine. Always stop the machine on a flat, level surface and block the tires before jacking up the machine.

FOR SAFETY: Before leaving or servicing machine, stop on level surface, set parking brake, turn off machine, and remove key.

The front jacking locations are on the flat bottom edge of the front of the machine frame.

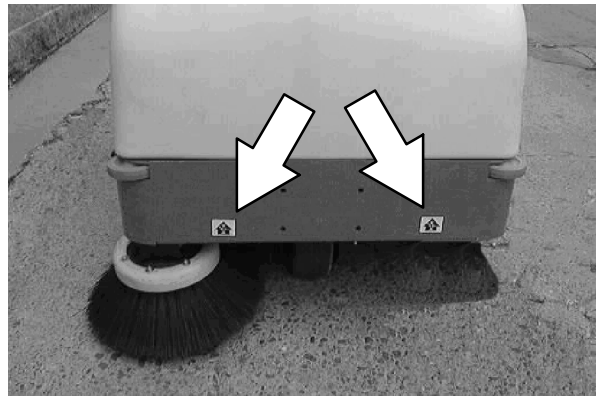

The rear jacking locations are on the corners of the rear frame.

FOR SAFETY: When servicing machine, block machine tires before jacking up machine.

FOR SAFETY: When servicing machine, jack up machine at designated locations only. Block machine up with jack stands.

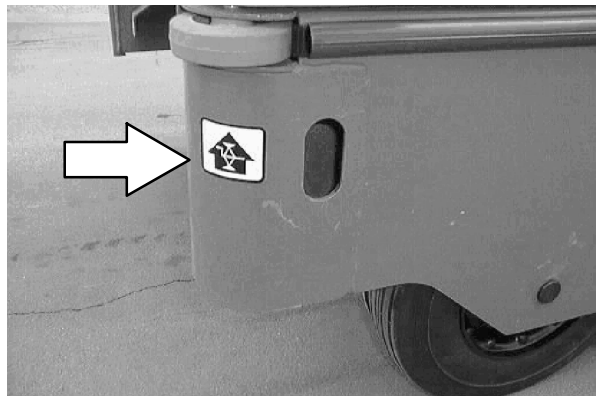

STORING MACHINE

Before storing the machine for an extended time, the machine needs to be serviced to lessen the chance of rust, sludge, and other undesirable deposits from forming.

HARDWARE INFORMATION

The following charts state standard plated hardware tightening ranges for normal assembly applications. Decrease the specified torque by 20% when using a thread lubricant. Do not substitute lower grade hardware for higher grade hardware. If higher grade hardware than specified is substituted, tighten only to the specified hardware torque value to avoid damaging the threads of the part being threaded into, as when threading into speed nuts or weldments.

STANDARD BOLT TORQUE CHART

Thread Size	SAE Grade 5 Torque ft lb (Nm)	SAE Grade 8 Torque ft lb (Nm)
0.25 in	7-10 (9-14)	10-13 (14-38)
0.31 in	15-20 (20-27)	20-26 (27-35)
0.38 in	27-35 (37-47)	36-47 (49-64)
0.44 in	43-56 (58-76)	53-76 (72-103)
0.50 in	65-85 (88-115)	89-116 (121-157)
0.62 in	130-170 (176-231)	117-265 (159-359)
0.75 in	215-280 (291-380)	313-407 (424-552)
1.00 in	500-650 (678-881)	757-984 (1026-1334)

NOTE: Decrease torque by 20% when using a thread lubricant.

METRIC BOLT TORQUE CHART





Thread Size	Class 8.8 Torque ft lb (Nm)	Class 10.9 Torque ft lb (Nm)
M4	2 (3)	3 (4)
M5	4 (5)	6 (8)
M6	7 (9)	10 (14)
M8	18 (24)	25 (34)
M10	32 (43)	47 (64)
M12	58 (79)	83 (112)
M14	94 (127)	133 (180)
M16	144 (195)	196 (265)
M20	260 (352)	336 (455)
M24	470 (637)	664 (900)

NOTE: Decrease torque by 20% when using a thread lubricant.

Exceptions to the above chart:

Check the machine for exceptions!

BOLT IDENTIFICATION

Identification Grade Marking	Specification and Grade
	SAE-Grade 5
	SAE-Grade 8
	ISO-Grade 8.8
	ISO-Grade 10.9

THREAD SEALANT AND LOCKING COMPOUNDS

Thread sealants and locking compounds may be used on this machine. They include the following:

Loctite 515 sealant - gasket forming material. TENNANT Part No. 75567, 15 oz (440 ml) cartridge.

Loctite 242 blue - medium strength thread locking compound. TENNANT Part No. 32676, 0.5 ml tube.

Loctite 271 red - high strength thread locking compound. TENNANT Part No. 19857, 0.5 ml tube.

CONTENTS

	Page
INTRODUCTION	2-3
BRAKES AND TIRES	2-4
SERVICE BRAKES	2-4
TO ADJUST SERVICE BRAKE	2-4
TO ADJUST PARKING BRAKE	2-5
TO REPLACE BRAKE PADS	2-6
REAR TIRES AND WHEELS	2-9
TO REMOVE REAR TIRE ASSEMBLY	2-9
TO INSTALL REAR TIRE ASSEMBLY	2-12
FRONT DRIVE WHEEL, AND WHEEL	
HOUSING SUPPORT	2-14
TO REMOVE FRONT TIRE AND	
WHEEL	2-14
TO INSTALL FRONT TIRE AND	
WHEEL	2-17
TO REPLACE FRONT WHEEL	
DRIVE CHAIN	2-20
TO REPLACE FRONT WHEEL	
HUB BEARINGS	2-23
TO REMOVE GEARBOX ASSEMBLY	2-24
TO INSTALL GEARBOX ASSEMBLY	2-26
TO REPLACE DRIVE WHEEL	
COGGED BELT	2-28
TO REPLACE GEARBOX BEARINGS	2-31
TO ADJUST STEERING CHAIN	2-35
TO REPLACE STEERING CHAIN ...	2-37
TO REPLACE STEERING HOUSING	
BEARINGS	2-40
TO REPLACE STEERING U-JOINT .	2-46
TO REPLACE SMALL STEERING	
SPROCKET	2-48
TO REPLACE LARGE STEERING	
SPROCKET	2-51
TO REPLACE FRONT WHEEL	
HOUSING NEEDLE BEARING/	
THRUST WASHERS	2-55
TO REPLACE FRONT WHEEL	
HOUSING CONE BEARING	2-61

INTRODUCTION

This section includes information on the main chassis related components for example the seat, steering, brakes, and tires.

BRAKES AND TIRES

SERVICE BRAKES

The service brakes on the model 6100E consists of a single disc and caliper located on the front tire and wheel assembly. The parking brake uses the same disc and caliper. The service brake and parking brake are each actuated with a foot pedal.

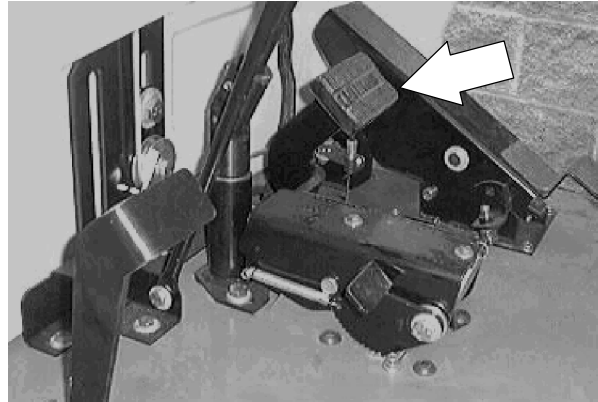

TO ADJUST SERVICE BRAKE

FOR SAFETY: Before Leaving Or Servicing Machine; Stop On Level Surface, place blocks in front and back of back wheels.

1. If the service brake pedal has excessive movement before the brake is activated, the service brake needs to be adjusted.
2. Go under the front of the machine and locate the disc brake caliper assembly.



3. Remove the small cotter pin from the caliper lever pin.

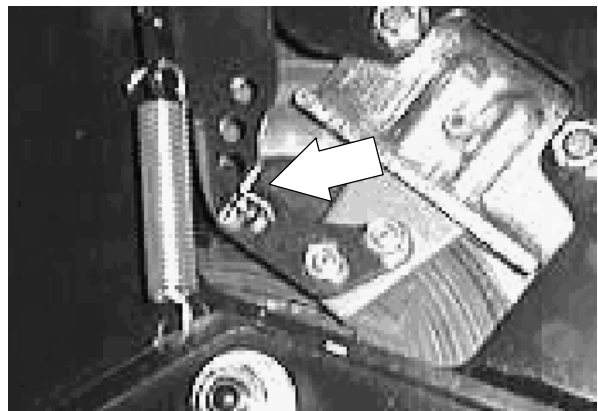

4. Move the lever up to the next hole in the brake bracket.

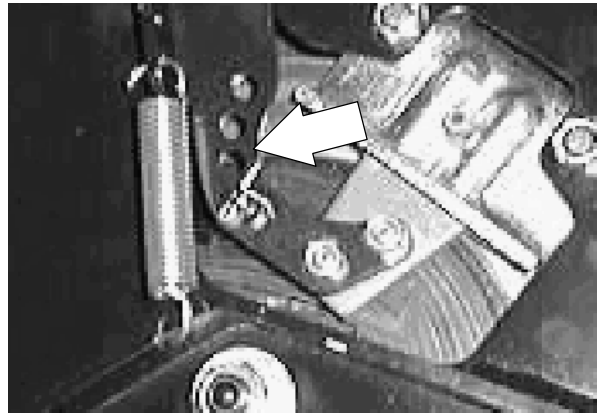

5. Reinstall the small cotter pin into the lever pin.

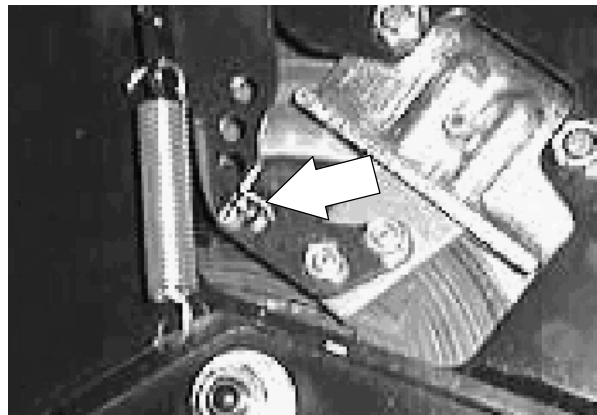

6. Go to the operators compartment and step on the service brake pedal. There should be just a small amount of movement before the brakes are engaged. If this is the case, the adjustment is complete, if not, repeat the previous step.

NOTE: If the lever does not reach the next hole, loosen the two screws holding the small lever to the caliper. The lever pin can now be moved up to the next hole. Retighten the hardware.

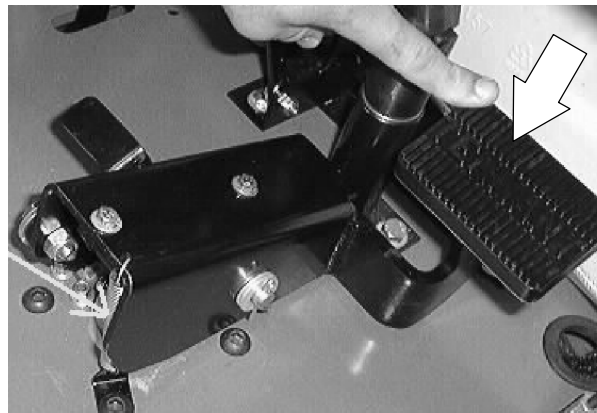

TO ADJUST PARKING BRAKE

The parking brake adjustment is made at the same time as the service brake. See TO ADJUST SERVICE BRAKE instructions.

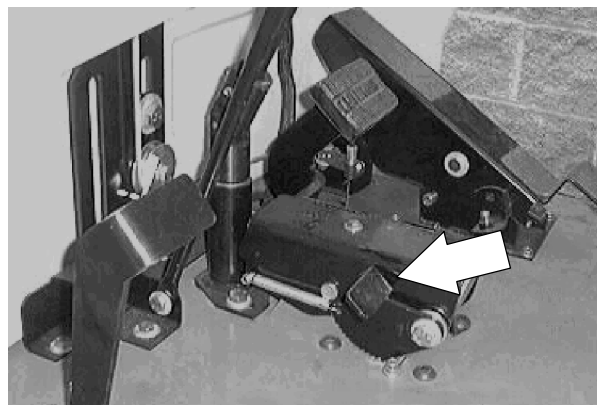

TO REPLACE BRAKE PADS

FOR SAFETY: Before Leaving Or Servicing Machine; Stop On Level Surface, Set Parking Brake.

1. Remove the front wheel assembly. See TO REMOVE FRONT TIRE AND WHEEL instructions in this section.

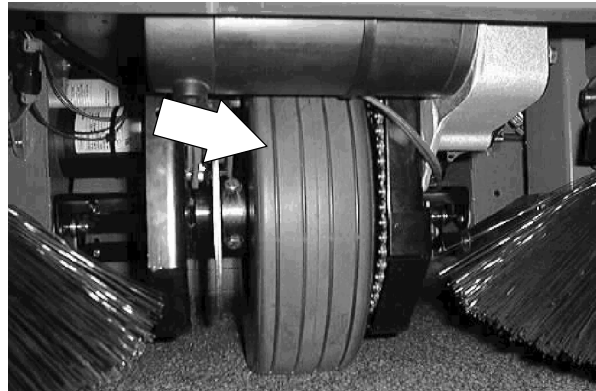

2. Remove the tension spring from the brake caliper lever and wheel housing.

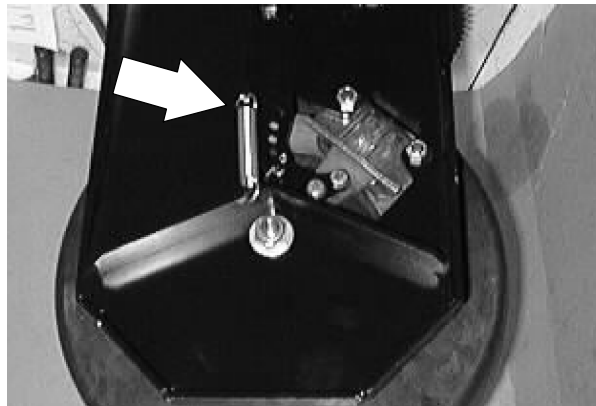

3. Remove the nuts from the shoulder screws holding the brake caliper to the wheel housing.

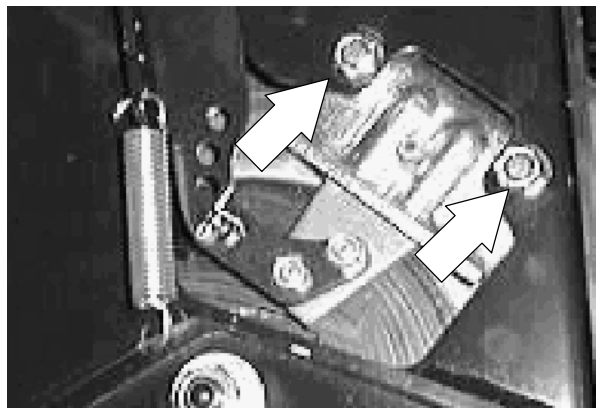

4. Remove the caliper assembly from the wheel housing. *Note the orientation of the caliper assembly on the wheel housing.*

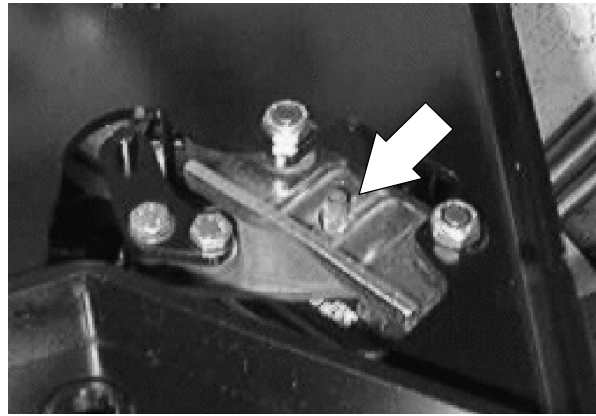

5. Remove the two shoulder screws from the caliper assembly.

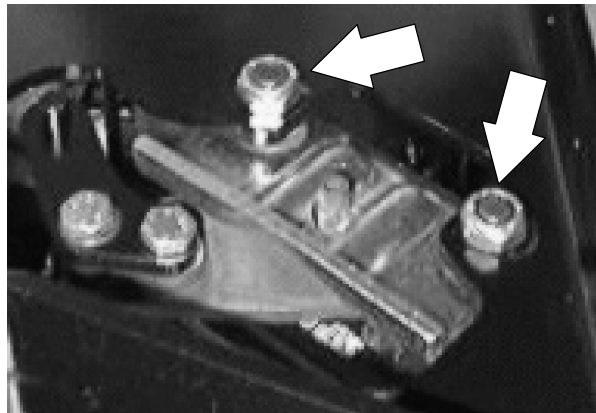

6. Pull the two brake pads out of the caliper assembly. *Note the orientation of the pads.*

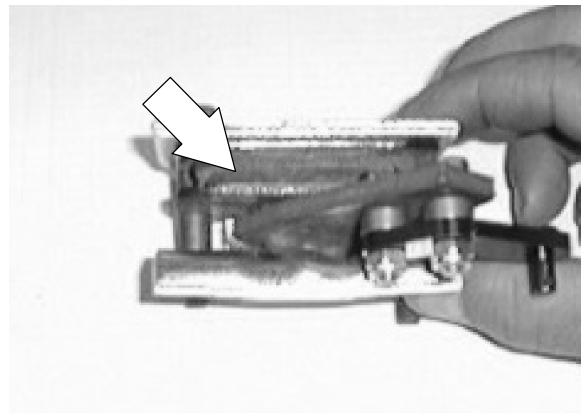

7. Install the new pads into the caliper assembly in the same orientation.



CHASSIS

8. Reinstall the two shoulder screws into the caliper and new brake pads.

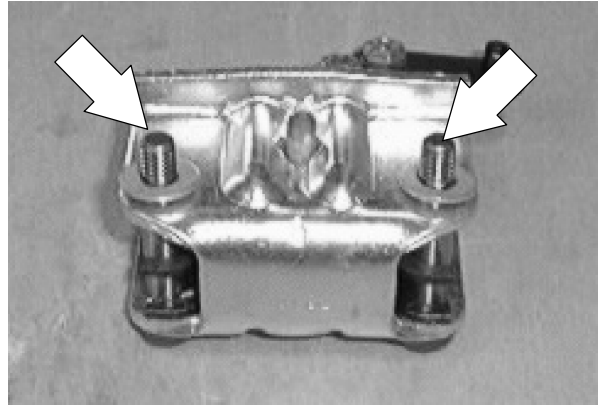

9. Reinstall the caliper assembly onto the wheel housing. Position the shoulder screws through the mount holes on the wheel housing. Reinstall the two nyloc nuts and tighten to 18 - 24 Nm (15 - 20 ft lb). Make sure the caliper free floats after the screws are tightened.

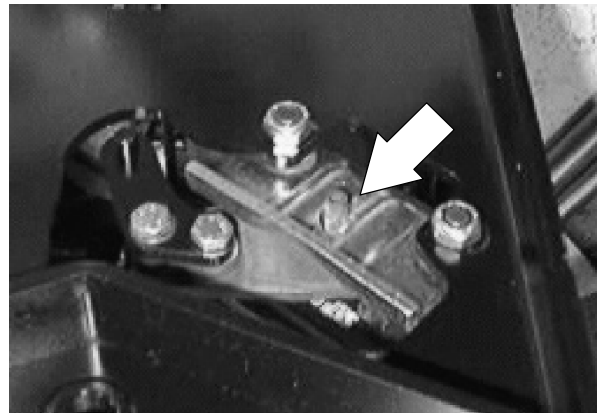

10. Reinstall the tension spring onto the brake caliper lever and wheel housing.

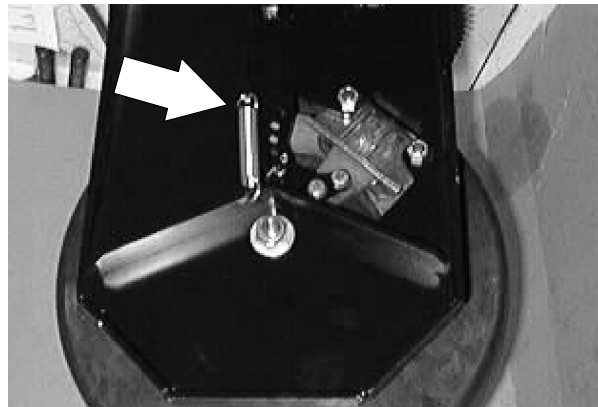

11. Reinstall the front tire and wheel assembly. See TO INSTALL FRONT TIRE AND WHEEL instructions in this section.

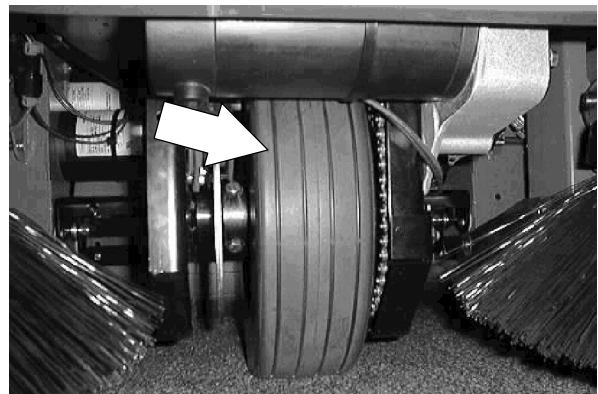

12. Operate the machine and check the brakes for proper operation.

REAR TIRES AND WHEELS

The rear tires on the 6100G are semi-pneumatic. The rear tires are free wheeling and have no braking capabilities.

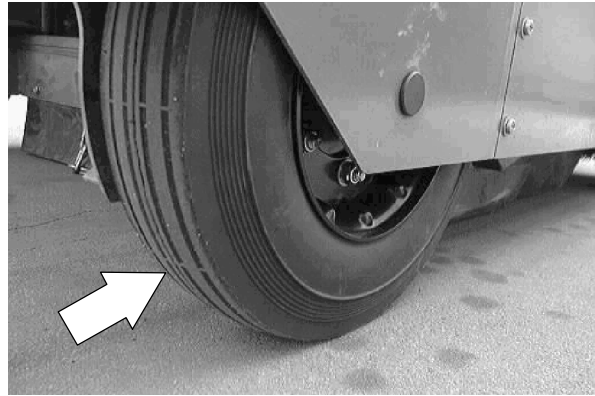
**TO REMOVE REAR TIRE ASSEMBLY**

FOR SAFETY: Before Leaving Or Servicing Machine; Stop On Level Surface, Set Parking Brake.

1. Remove the debris hopper from the rear of the machine.



2. Jack up the machine at the rear jack point. Place a jack stand under the machine frame.

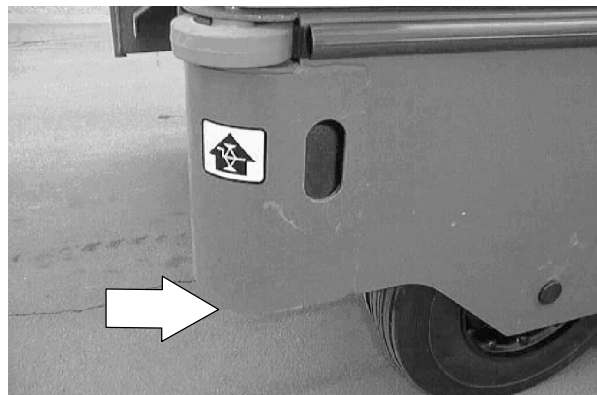

CHASSIS

3. Go to the rear, inside of the machine frame and locate the large nyloc nut and washer holding the rear wheel axle to the machine. Remove the nyloc nut and washer.

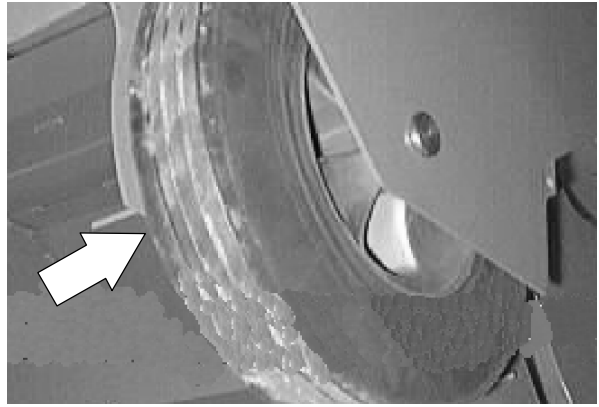

4. Support the rear wheel and remove the axle shaft.

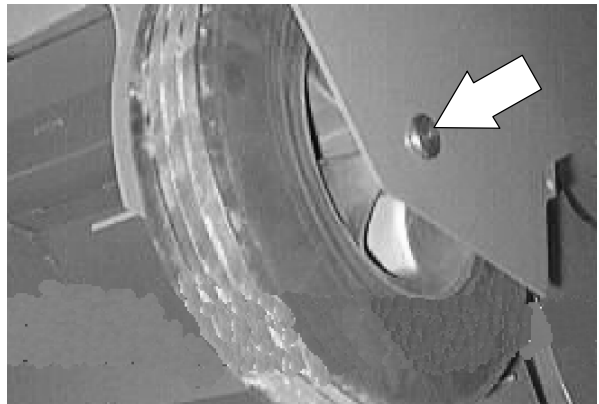

5. Remove the rear tire assembly from the machine.

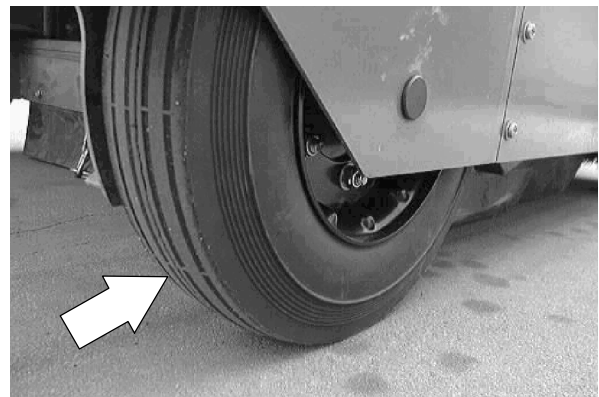

6. Remove the three hex screws and nuts holding the wheel hub to the tire assembly.

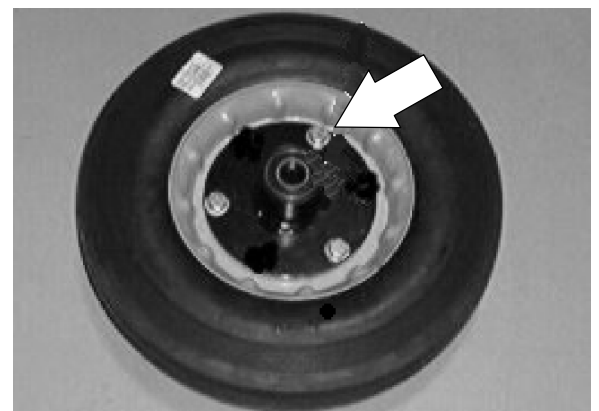

7. Remove the hub assembly from the tire assembly.

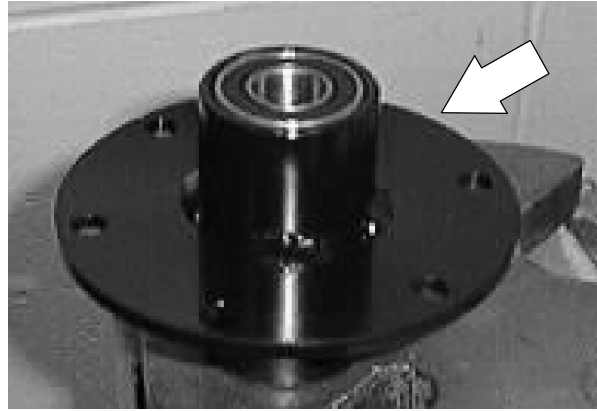

TO INSTALL REAR TIRE ASSEMBLY

FOR SAFETY: Before Leaving Or Servicing Machine; Stop On Level Surface, Set Parking Brake.

1. Position the rear hub assembly onto the new tire assembly. Place the three screws through the hub then through the wheel. Install the nuts. *Center the hub on the wheel.* Tighten the nuts to 18 - 24 Nm (15 - 20 ft lb).

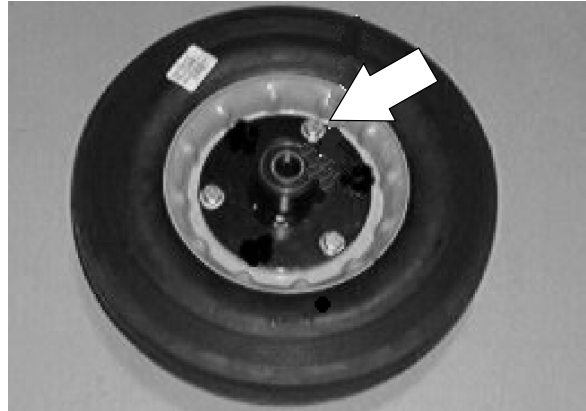

2. Install the tire and hub assembly into the machine with the hub positioned on the inside of the machine frame.

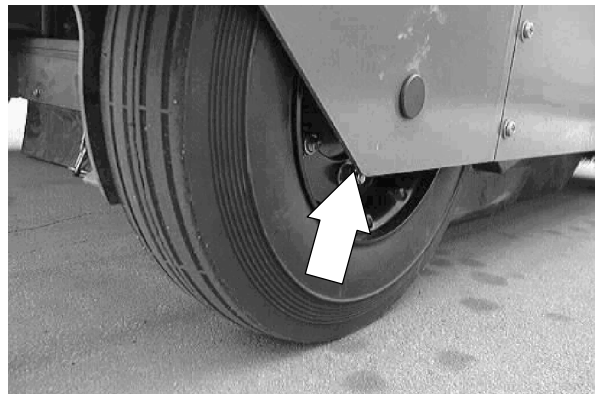

3. Hold the wheel in position and install the axle shaft from to outside of the machine frame. *Note the "D" shape of the frame mount hole and the "D" on the axle shaft.* Line these two up and push the axle all the way into the mount hole.

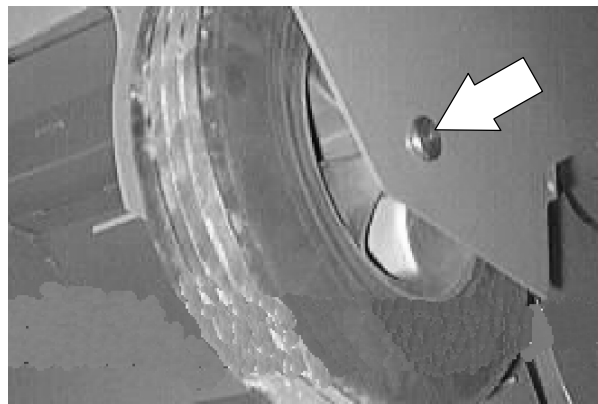

4. Go to the inside of the machine frame and install the washer and nyloc nut. Tighten to 37 - 48 Nm (26 - 34 ft lb).

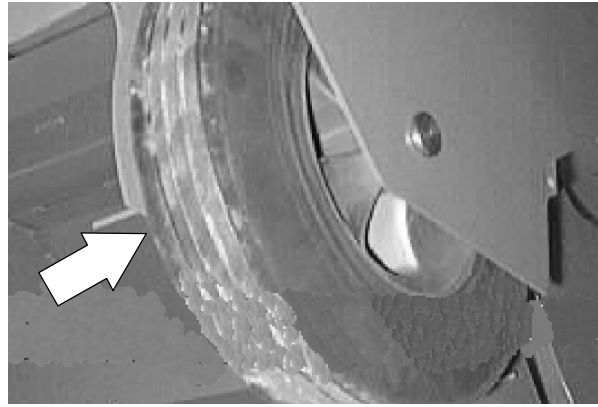

5. Spin the tire assembly to make sure it turns freely.

6. Remove the jack stand and lower the machine to the floor.

7. Operate the machine for proper operation.

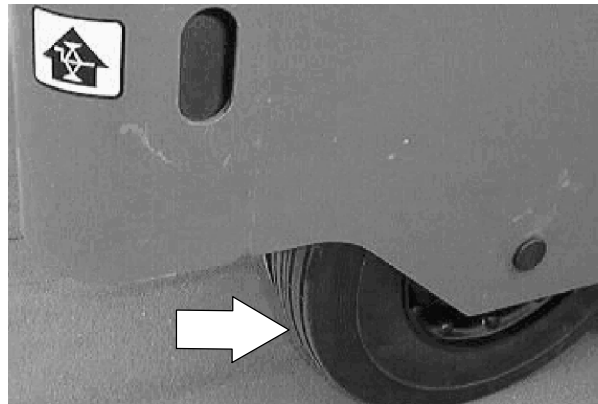

CHASSIS

FRONT DRIVE WHEEL, AND WHEEL HOUSING SUPPORT

The model 6100E is propelled forward and reverse by the front wheel assembly. An electric motor turns a cogged belt that in turn drives a O-ring chain that turns the front tire assembly.

The steering on the model 6100E is controlled by a steering wheel which turns a chain that is connected to the front wheel housing. The front wheel housing turns on a large bearing and rubber seal.

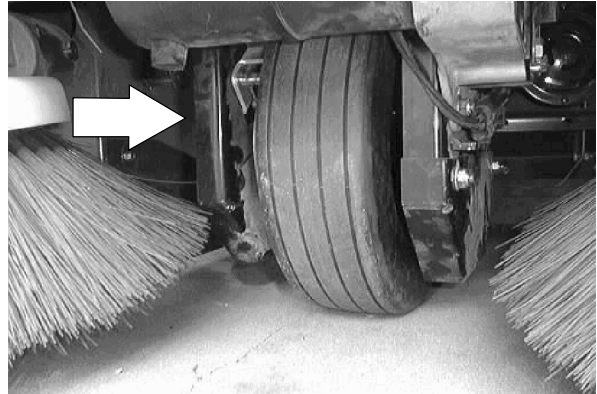

TO REMOVE FRONT TIRE AND WHEEL

FOR SAFETY: Before Leaving Or Servicing Machine; Stop On Level Surface, place blocks in front and back of the rear tires.

1. Jack up the front of the machine at the jack point. Install jack stands under the machine frame.

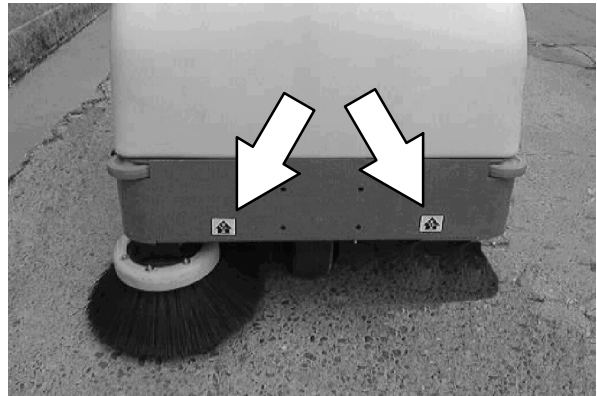

2. Remove the two nuts holding the chain guard to the wheel support. Remove the chain guard.

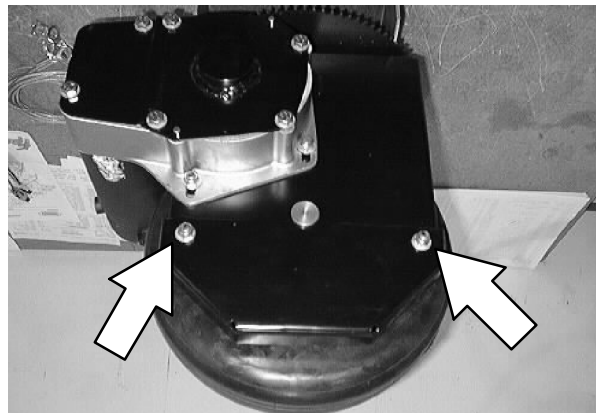

- Loosen the three nuts holding the drive motor gearbox to the wheel support. Let the gearbox drop down so the drive chain has some slack.

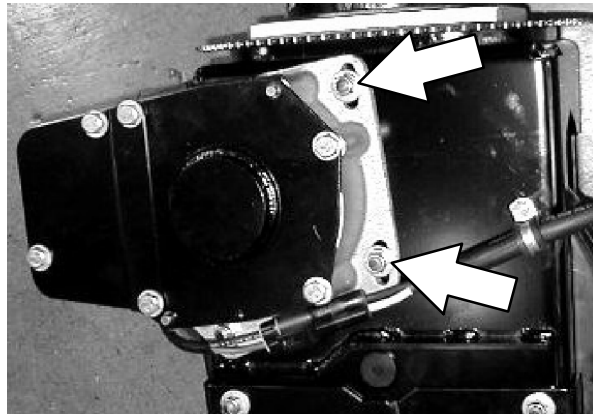

- Turn the front tire until the master link is visible at the bottom of the drive sprocket. Remove the master link from the drive chain. **Make sure to retain the four small O-rings from behind the master link clip.**

NOTE: Try to keep the chain on the upper sprocket when removing the wheel.

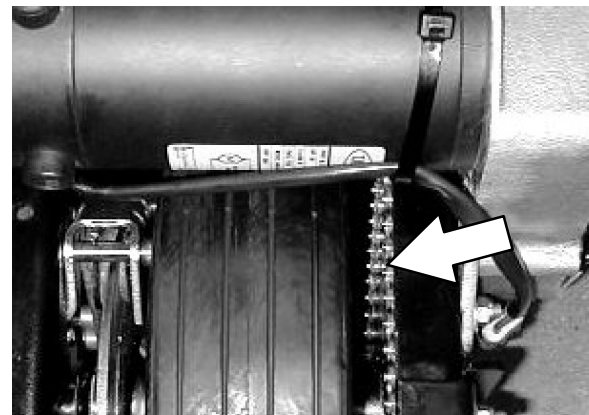

- Remove the large nut and washer from the wheel axle.
- Support the front drive wheel. Remove the axle from the front wheel.



- Let the front wheel drop down and out of the brake caliper. Remove the front drive wheel from the machine.

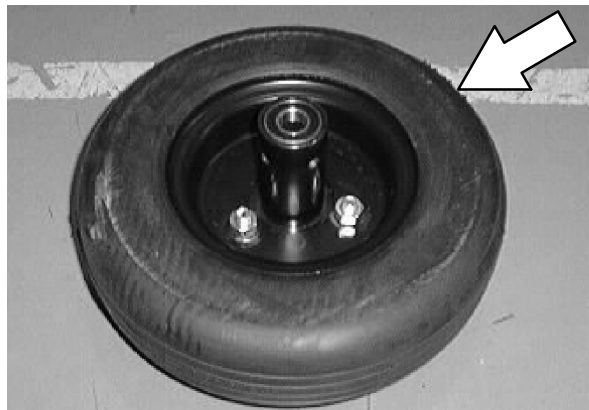

CHASSIS

8. Remove the four screws holding the brake disc to the front hub assembly. Make sure to retain the four steel sleeves. Pull the brake disc off the hub.

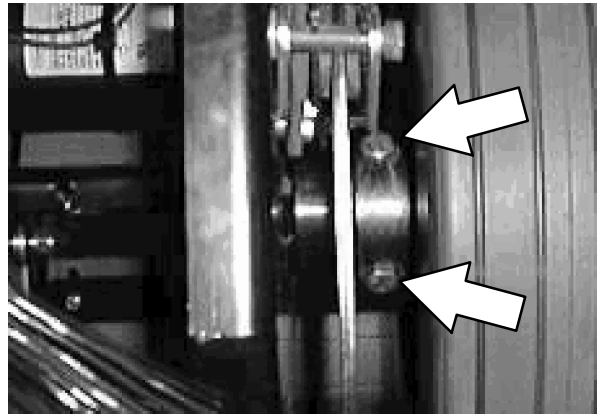

9. Remove the three wheel nuts holding the tire to the front hub. Remove the tire assembly from the hub.

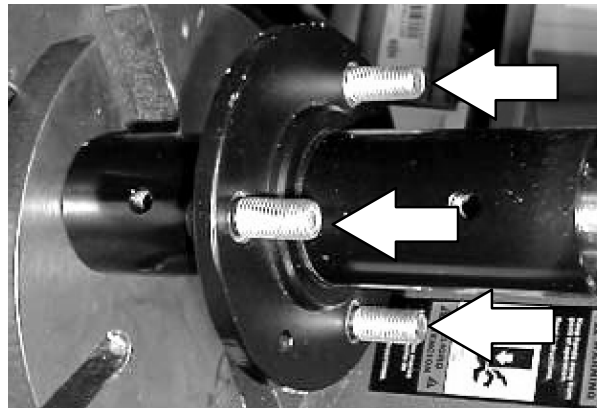

TO INSTALL FRONT TIRE AND WHEEL

FOR SAFETY: Before Leaving Or Servicing Machine; Stop On Level Surface, place blocks in front and back of the rear tires.

1. Position the new front tire onto the front hub assembly. Reinstall the three wheel nuts and tighten to 64 - 83 Nm (47 - 61 ft lb).



2. Reinstall the brake disc onto the front hub assembly.

NOTE: Place a small amount of grease in the ID of the brake disc. The hub of the brake disc is positioned toward the tire.

3. Reinstall the four hex screws and steel sleeves. Use red loctite (271) on the threads of the screws and tighten to 18 - 24 Nm (15 - 20 ft lb). Tighten these screws in a "criss-cross" pattern. **Make sure the disc floats on the hub.**

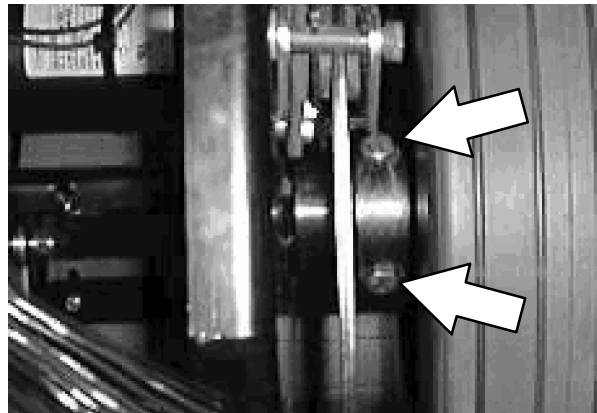

4. Position the front drive wheel assembly into the wheel housing. The brake disc is positioned on the left side of the wheel support.

NOTE: Use a screw driver to spread the brake pads apart to ease the installation of the assembly into the wheel support.

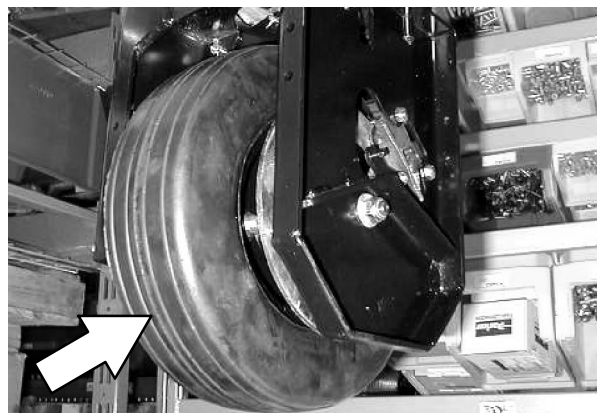

CHASSIS

5. Line up the wheel hub bearings with the mount holes on the wheel support.
6. Push the wheel axle, from the right hand side, into the wheel housing and wheel hub. Note the “D” shape of the wheel support mount hole and the “D” on the axle shaft. Line these two up and push the axle all the way into the mount hole.

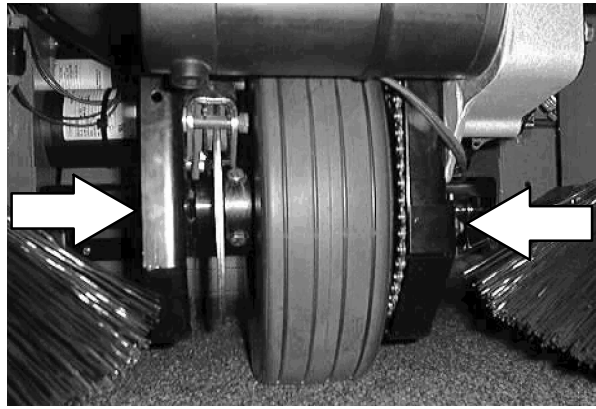

7. Install the washer and nyloc nut onto the axle shaft. Tighten to 64 - 83 Nm (47 - 61 ft lb).



8. Spread the drive chain and install around the large sprocket on the front wheel assembly. Reinstall the master link. **Make sure the four small O-rings are in place behind the master link clip.**

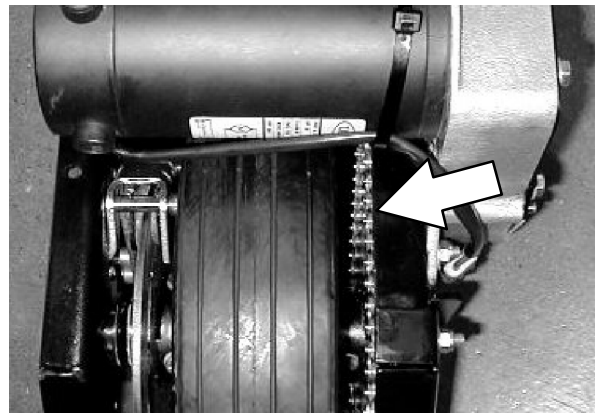

9. Push the motor gearbox up until the drive chain is tight (+/- 1/8 inch at mid-point). Tighten nuts to 18 - 24 Nm (15 - 20 ft lb).

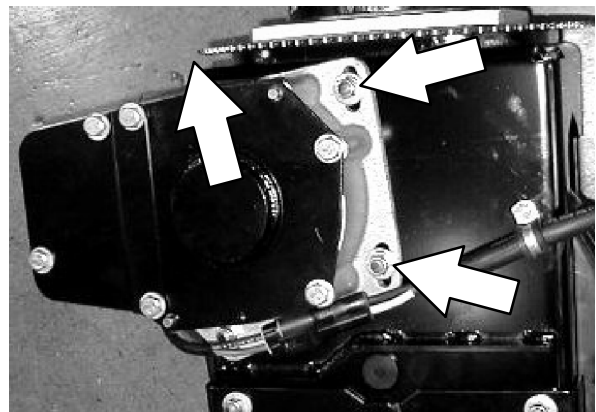

10. Reinstall the drive chain guard and tighten the two nuts to 18 - 24 Nm (15 - 20 ft lb).

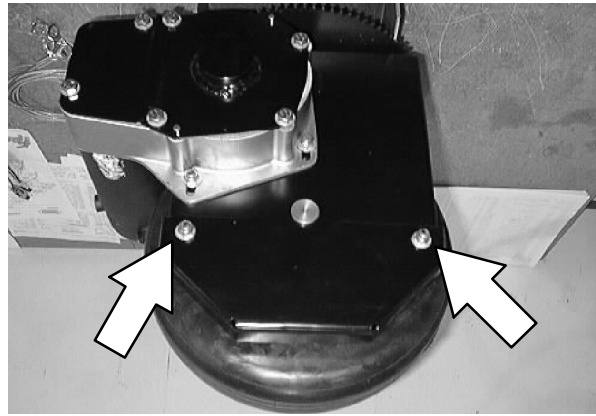

11. Remove the jack stands and lower the machine to the floor. Operate the machine and check for proper operation.

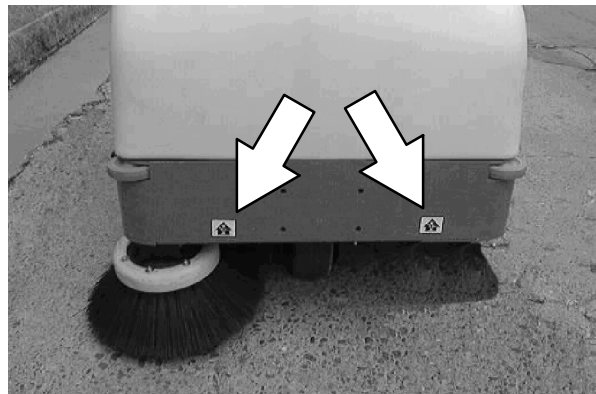

CHASSIS

TO REPLACE FRONT WHEEL DRIVE CHAIN

FOR SAFETY: Before Leaving Or Servicing Machine; Stop On Level Surface, place blocks in front and back of the rear tires.

1. Jack up the front of the machine at the jack point. Install jack stands under the machine frame.

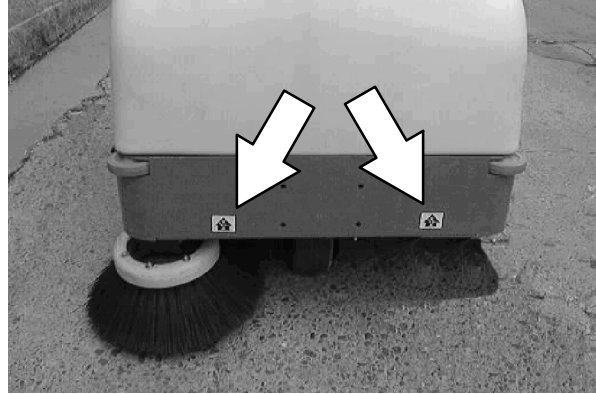

2. Remove the two nuts holding the chain guard to the wheel support. Remove the chain guard.

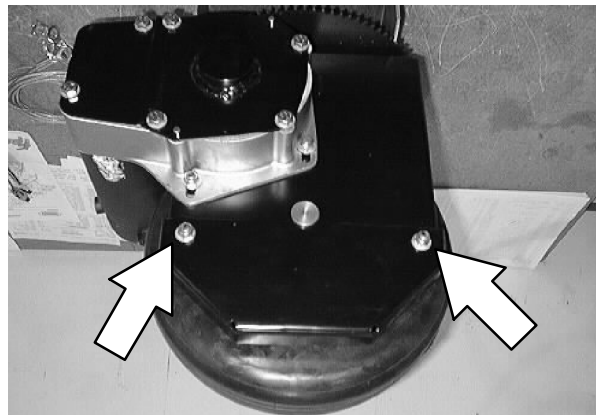

3. Loosen the three nuts holding the drive motor gearbox to the wheel support. Let the gearbox drop down so the drive chain has some slack.

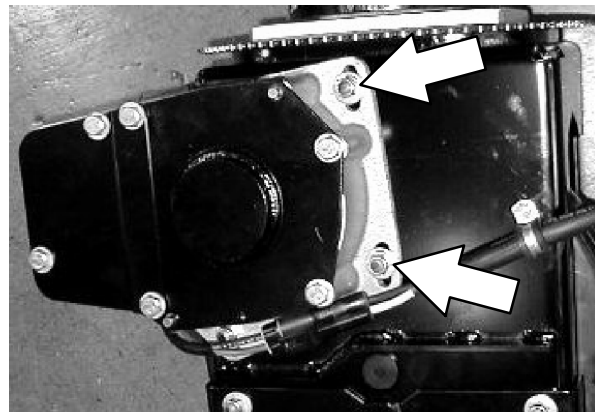

- Turn the front tire until the master link is visible at the bottom of the drive sprocket. Remove the master link from the drive chain. **Make sure to retain the four small O-rings from behind the master link clip.**

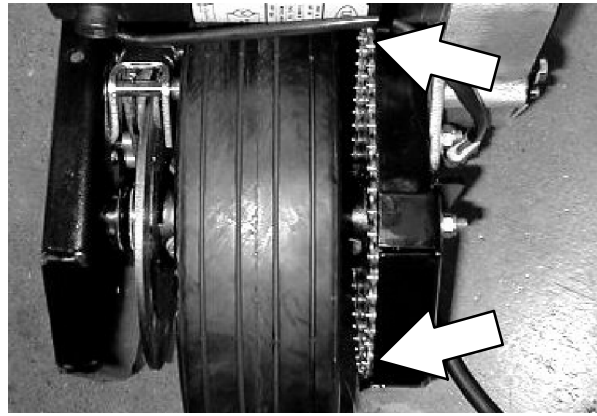

- Pull the old chain off the drive motor sprocket and drive wheel sprocket. Remove the old drive chain from the machine.

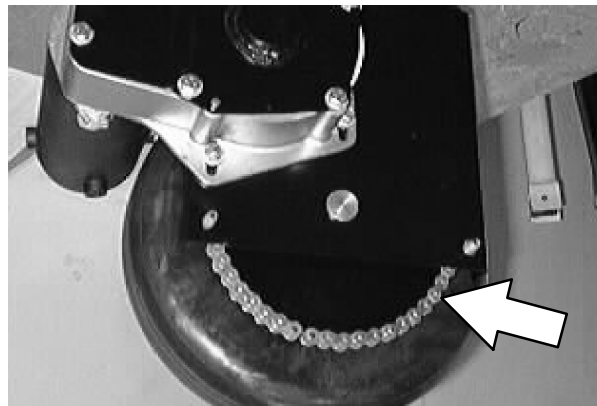

- Reinstall the new drive chain around the drive sprocket on the drive motor and front wheel assembly. Reinstall the master link. **Make sure the four small O-rings are in place behind the master link clip.**



- Push the gearbox assembly up until the chain is tight ($\pm 1/8$ inch at mid-point). Tighten nuts to 18 - 24 Nm (15 - 20 ft lb).

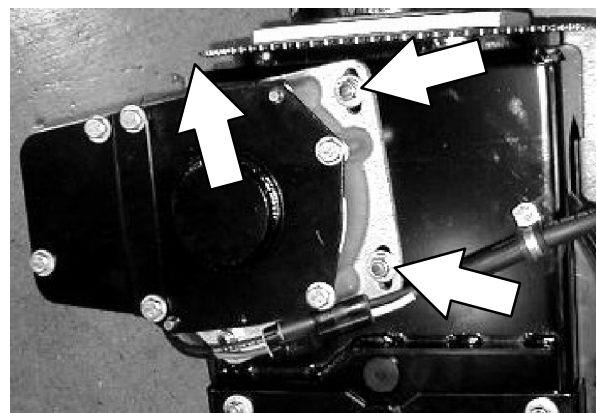

CHASSIS

8. Reinstall the drive chain guard and tighten the two nuts to 18 - 24 Nm (15 - 20 ft lb).

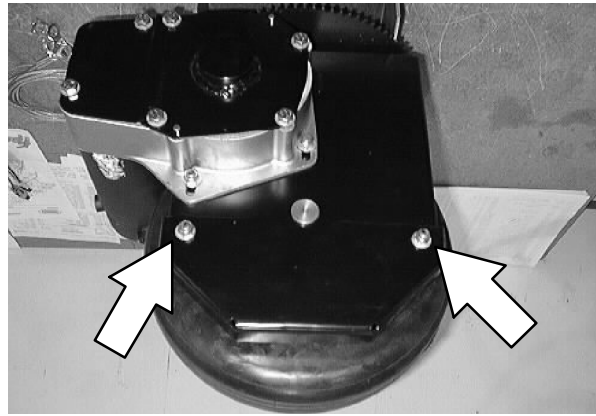

9. Remove the jack stands and lower the machine to the floor. Operate the machine and check the new drive chain for proper operation.

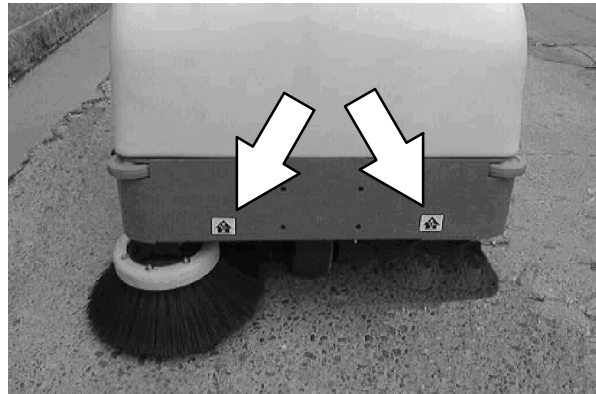

TO REPLACE FRONT WHEEL HUB BEARINGS

FOR SAFETY: Before Leaving Or Servicing Machine; Stop On Level Surface, place blocks in front and back of the rear tires.

1. Remove the front tire and wheel assembly. See TO REMOVE FRONT TIRE AND WHEEL instructions in this section.



2. Use a long screw driver or punch to hammer the two bearings out of the front hub assembly. Discard the old bearings.

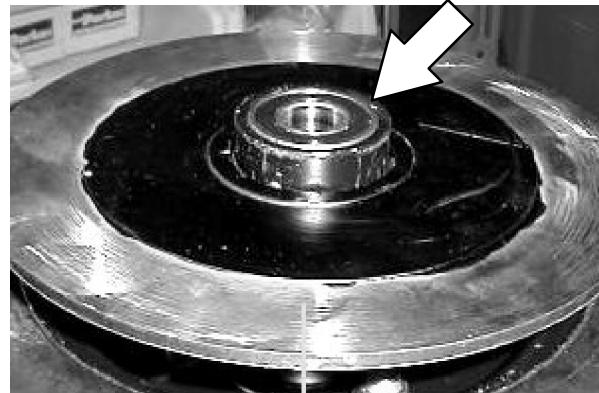

3. Use an arbor press to install the new bearings into the front hub. Push the bearings down until they are seated flush against the housing.



4. Reinstall the front wheel assembly. See TO INSTALL FRONT TIRE AND WHEEL instructions in this section.

TO REMOVE GEARBOX ASSEMBLY

FOR SAFETY: Before Leaving Or Servicing Machine; Stop On Level Surface, place blocks in front and back of the rear tires.

1. Jack up the front of the machine at the jack point. Install jack stands under the machine frame.

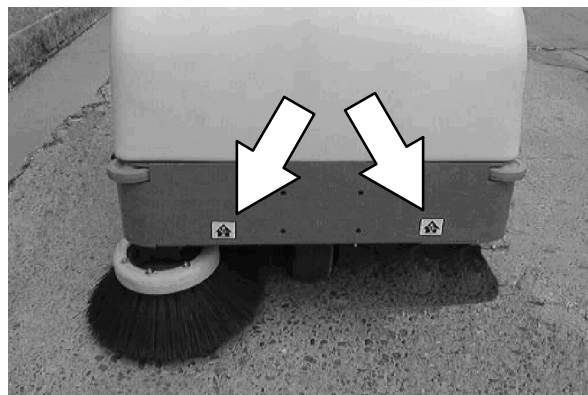

2. Remove the two nuts holding the chain guard to the wheel support. Remove the chain guard.

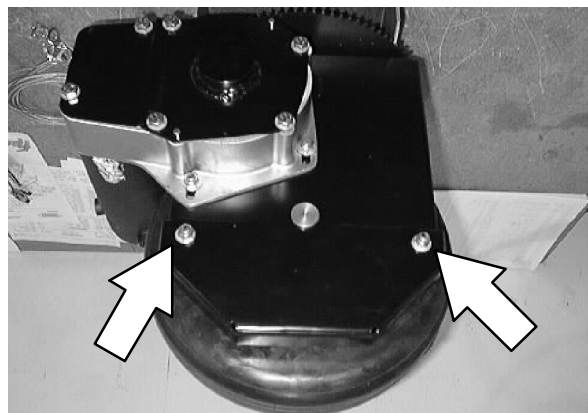

3. Loosen the three nuts holding the gearbox assembly to the wheel support. Let the gearbox drop down so the drive chain has some slack.

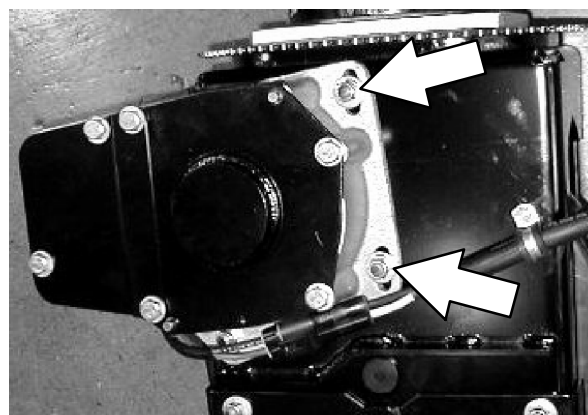

- Turn the front tire until the master link is visible at the bottom of the drive sprocket. Remove the master link from the drive chain. **Make sure to retain the four small O-rings from behind the master link clip.**

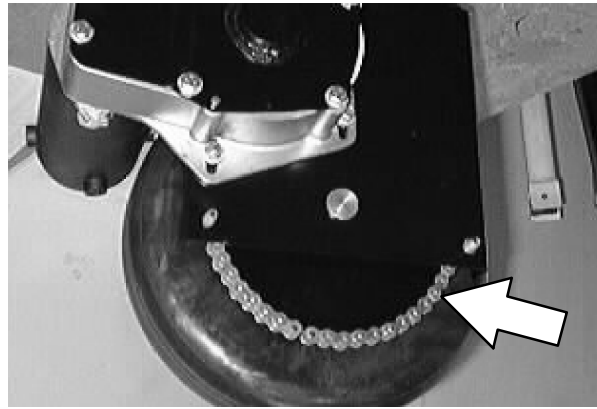

- Pull the chain off the drive motor sprocket and drive wheel sprocket. Remove the drive chain from the machine.



- Disconnect the drive motor from the main electrical harness.

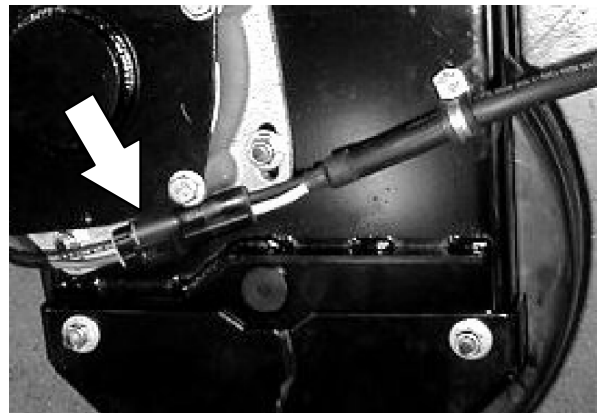

- Finish removing the three nuts and washers holding the gearbox assembly to the wheel support. Remove the gearbox assembly from the machine.

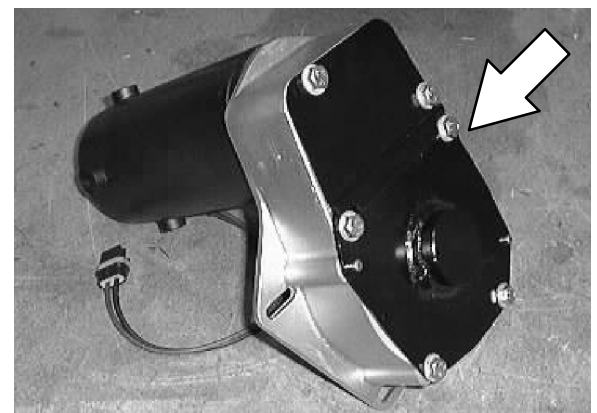

CHASSIS

TO INSTALL GEARBOX ASSEMBLY

FOR SAFETY: Before Leaving Or Servicing Machine; Stop On Level Surface, place blocks in front and back of the rear tires.

1. Position the gearbox assembly onto the wheel support. *The three slots on the gearbox go over the three studs on the wheel support.*

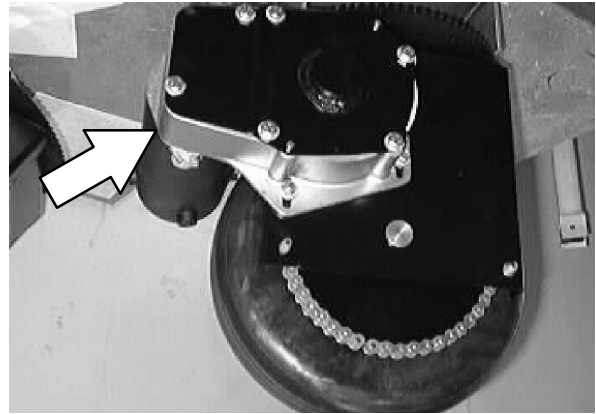

2. Install the three washers and nuts onto the wheel housing studs. Leave loose for now.

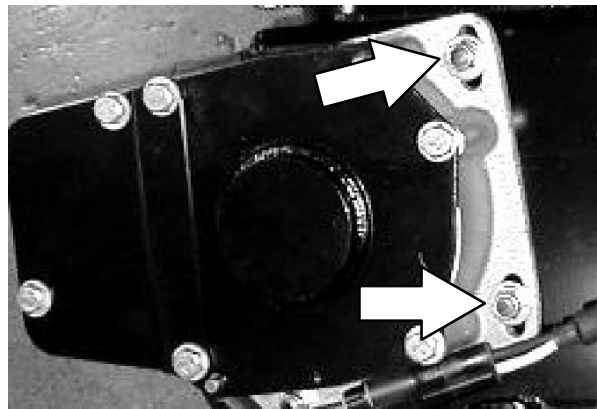

3. Reinstall the drive chain around the drive sprocket on the drive motor and front wheel assembly. Reinstall the master link. **Make sure the four small O-rings are in place behind the master link clip.**



4. Push the gearbox assembly up until the chain is tight ($\pm 1/8$ inch at mid-point). Tighten nuts to 18 - 24 Nm (15 - 20 ft lb).

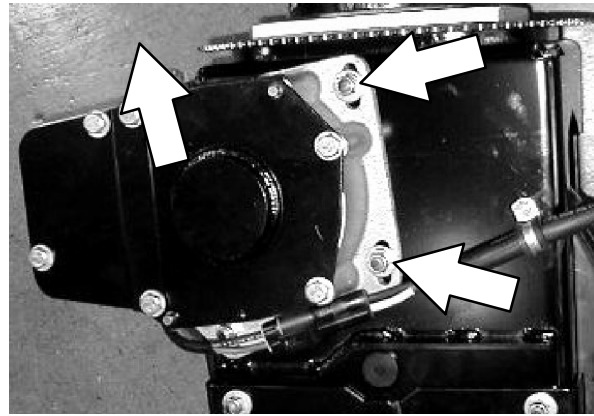

5. Reinstall the drive chain guard and tighten the two nuts to 18 - 24 Nm (15 - 20 ft lb).

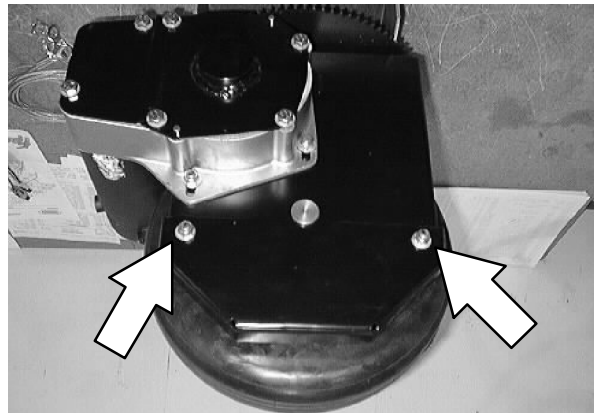

6. Reconnect the drive motor to the main electrical harness.

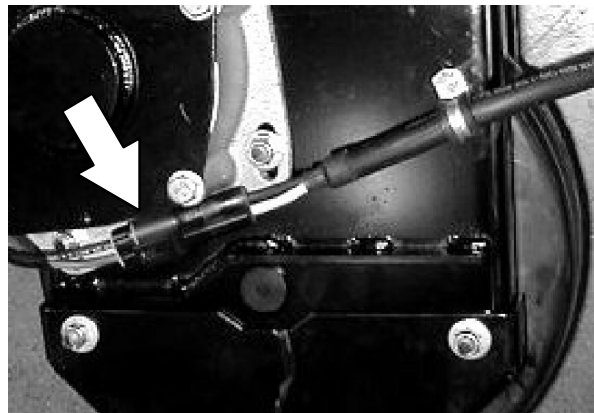

7. Remove the jack stands and lower the machine to the floor. Operate the machine and check the gearbox assembly for proper operation.

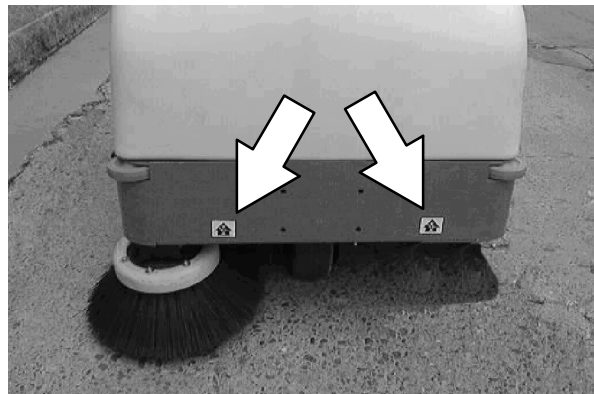

CHASSIS

TO REPLACE DRIVE WHEEL COGGED BELT

FOR SAFETY: Before Leaving Or Servicing Machine; Stop On Level Surface, place blocks in front and back of the rear tires.

1. Jack up the front of the machine at the jack point. Install jack stands under the machine frame.

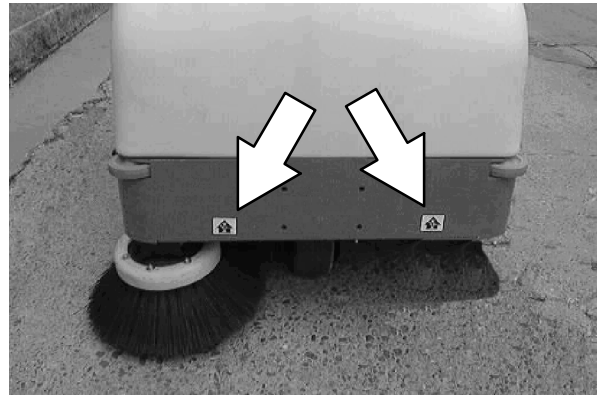

2. Disconnect the drive motor from the main electrical harness. Turn the steering wheel all the way to the right.

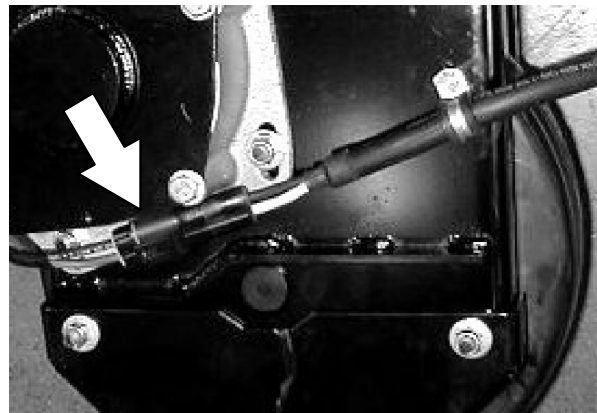

3. Remove the six hex screws holding the two black covers to the side of the gearbox.

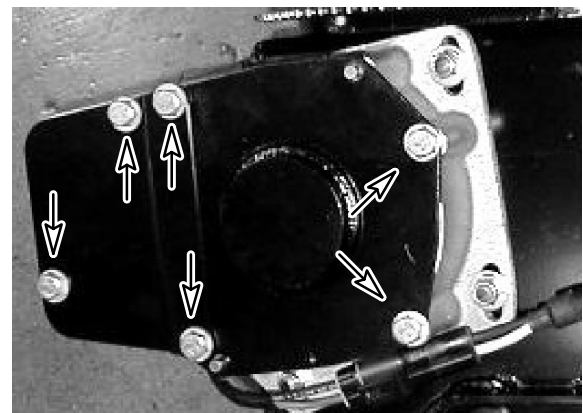

4. Remove the cover on the front side of the gearbox first.

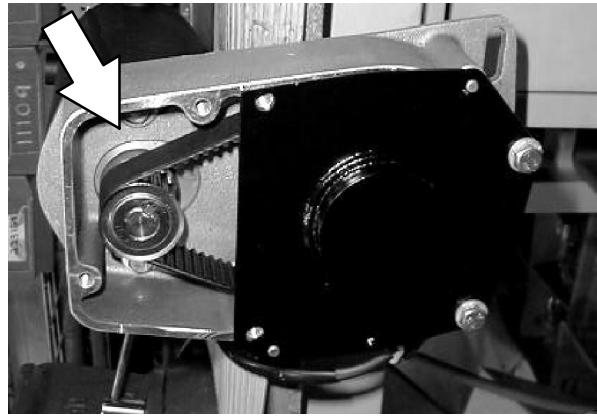

5. Next, remove the bearing cover. *You may have to lightly pry the second cover off the locating pins.*

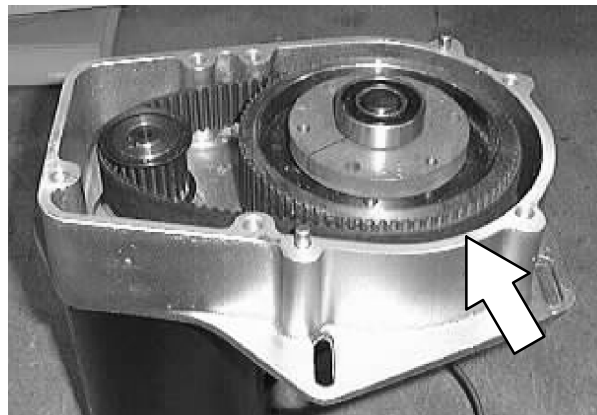

6. Loosen the two hex screws holding the electric drive motor to the back side of the gearbox assembly. Let the motor slide toward the back of the machine. The cogged belt will now be loose on the pulleys.

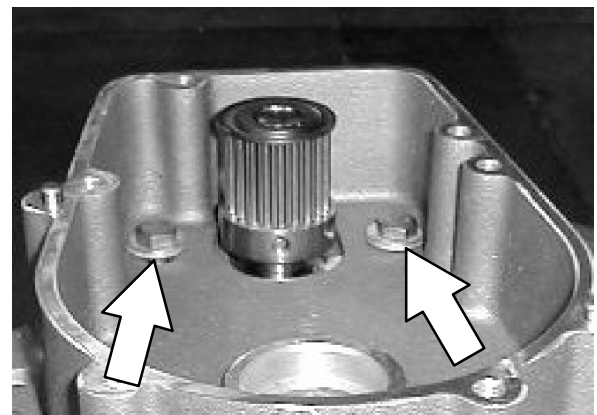

7. Remove the old cogged belt from both drive pulleys. Discard the old belt.

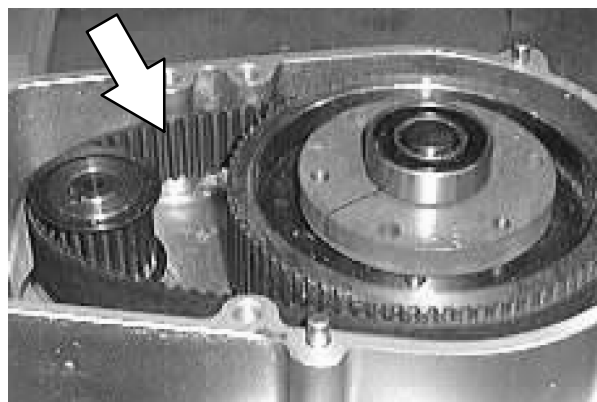

CHASSIS

8. Position the new cogged belt onto the large and small pulleys.

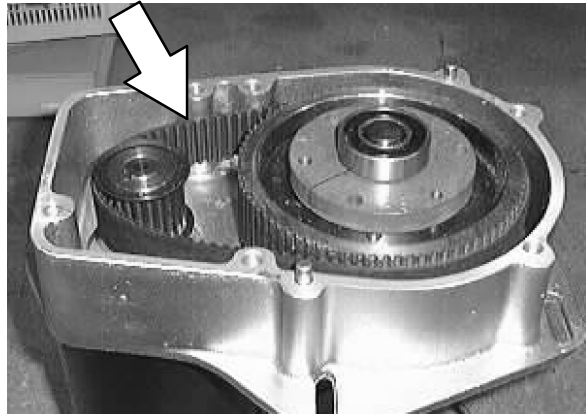

9. Reinstall the bearing side cover onto the gearbox. Make sure the cover is seated down over the locating pins. Install two hex screws for now. Tighten the screws to 18 - 24 Nm (15 - 20 ft lb).

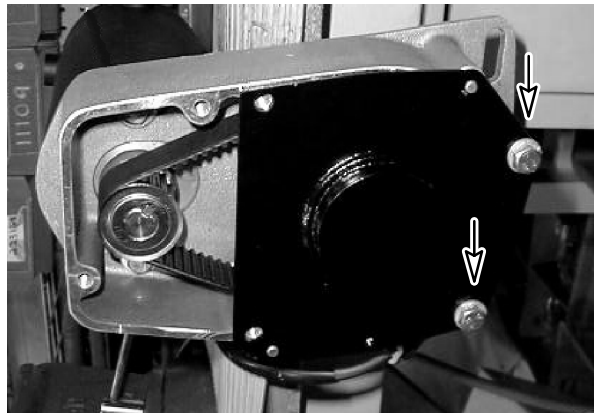

10. Use a large channel lock pliers to pull the drive motor to the front of the gearbox. Place one side of the pliers over the small pulley and the other side of the pliers on the front side of the gearbox. Squeeze the pliers until the belt is tight (*1/16 inch play at midpoint*). Tighten the two motor mount screws to 18 - 24 Nm (15 - 20 ft lb).

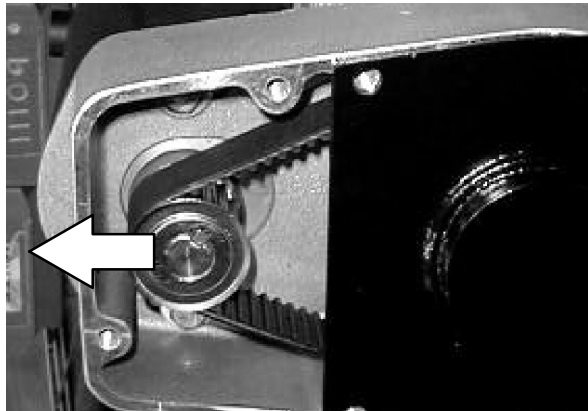

11. Install the second belt cover onto the gearbox. Install the remaining four hex screws and tighten to 18 - 24 Nm (15 - 20 ft lb). Plug the drive motor into the main electrical harness.

12. Remove the jack stands and lower the machine to the floor. Operate the machine and check the gearbox assembly for proper operation.

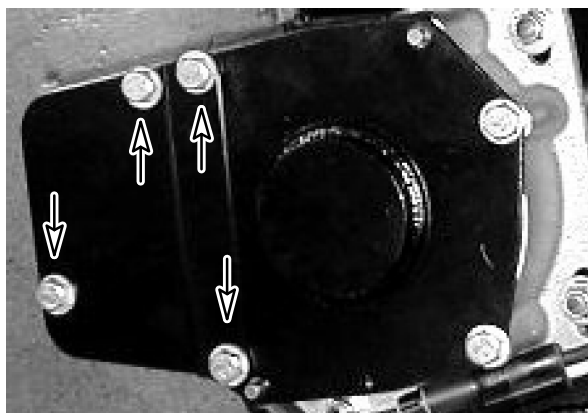

TO REPLACE GEARBOX BEARINGS

FOR SAFETY: Before Leaving Or Servicing Machine; Stop On Level Surface, place blocks in front and back of the rear tires.

1. Remove the gearbox assembly from the machine. See TO REMOVE GEARBOX ASSEMBLY instructions in this section.

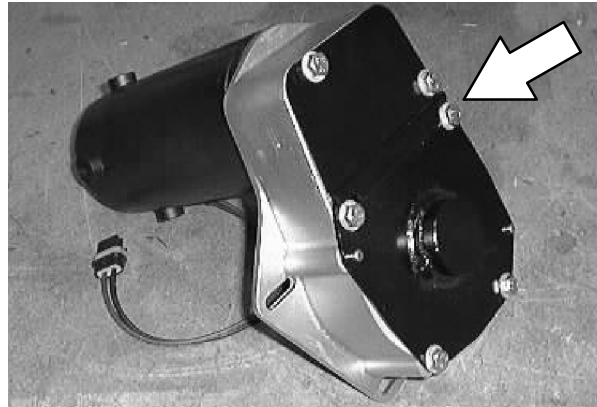

2. Loosen the two set screws on the small sprocket on the gearbox assembly. Remove and retain the small sprocket, woodruff key, and foam washer.

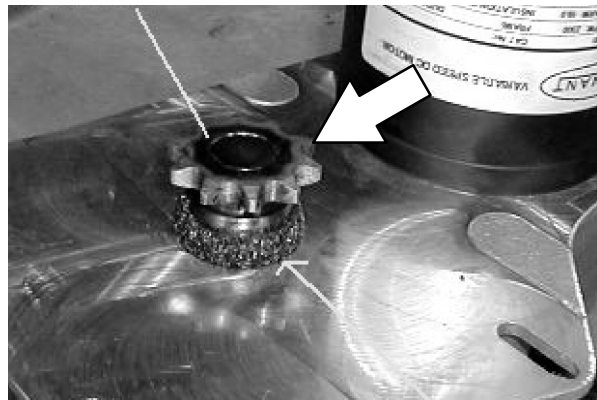

3. Go to the other side of the gearbox assembly. Remove the six hex screws holding the two black covers to the side of the gearbox.

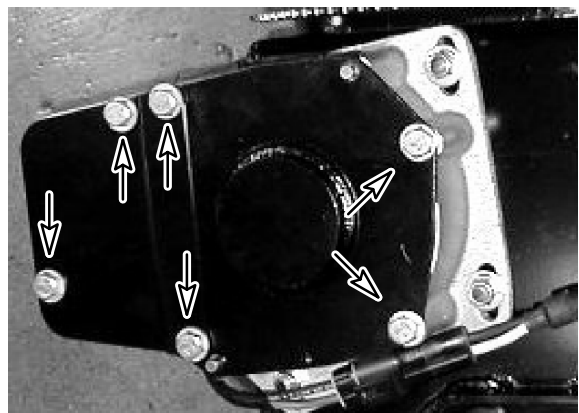

CHASSIS

4. Remove the smaller cover first.

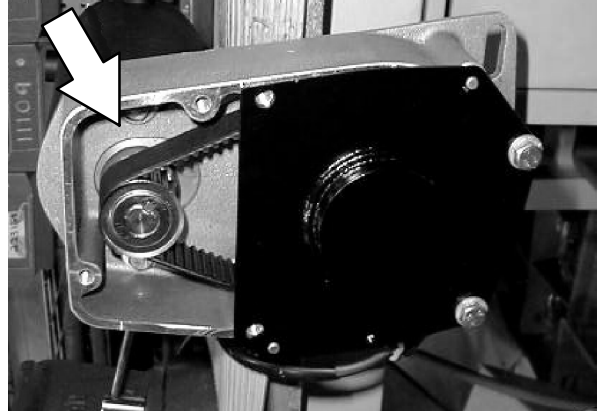

5. Remove the bearing cover second. *You may have to lightly pry the second cover off the locating pins.*

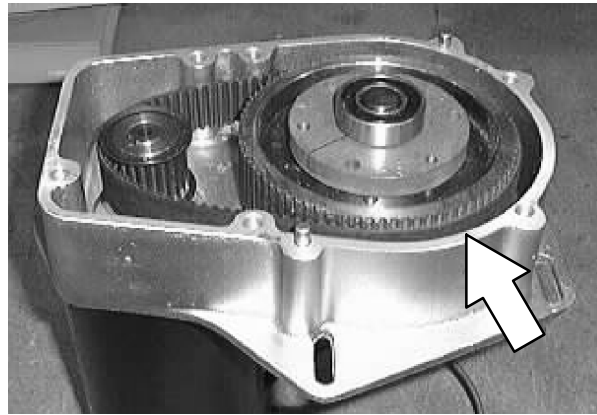

6. Loosen the two hex screws holding the electric drive motor to the back side of the gearbox assembly. Let the motor slide toward the large sprocket. The cogged belt will now be loose on the pulleys. Remove the cogged belt from both drive pulleys.

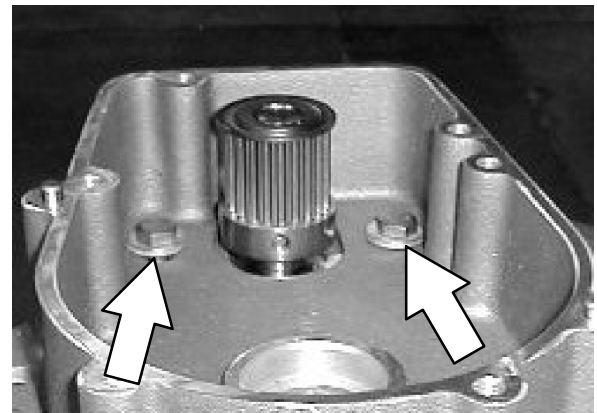

7. Pull the large pulley out of the gearbox. You may have to lightly tap on the shaft to dislodge the inner bearing from the bottom case of the gearbox assembly. *Remove the three hex screws holding the hub to the sprocket.*

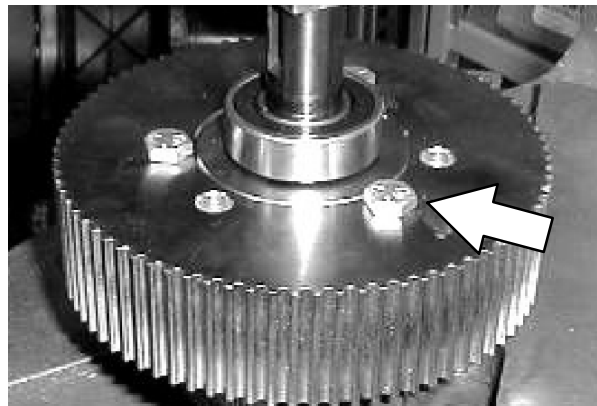

- Use an arbor press to remove the pulley shaft and both gearbox bearings. *Note the orientation of the bearings on the pulley shaft. Discard the old bearings.*

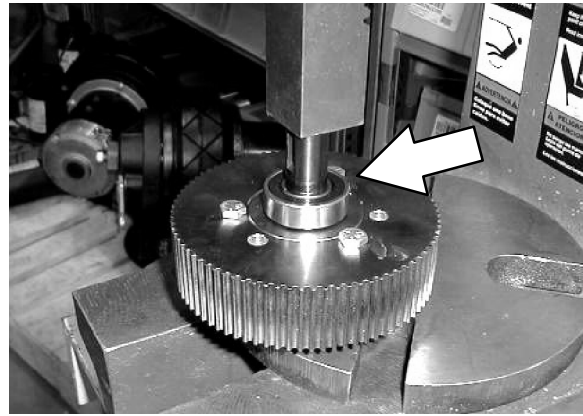

- Install the new bearings onto the pulley shaft in the same orientation as the old bearings. Reinstall the hub and new bearings into the sprocket. Tighten the three hex screws to 11 - 14 Nm (7 - 10 ft lb).

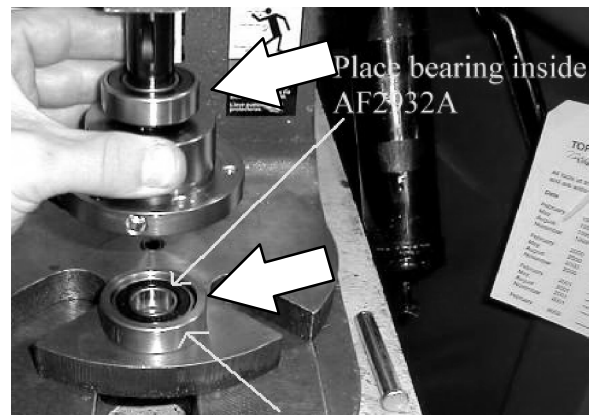

- Position the large belt pulley, shaft, and bearing assembly back into the bottom case of the gearbox assembly. Make sure the inner bearing is seated properly in the lower case.

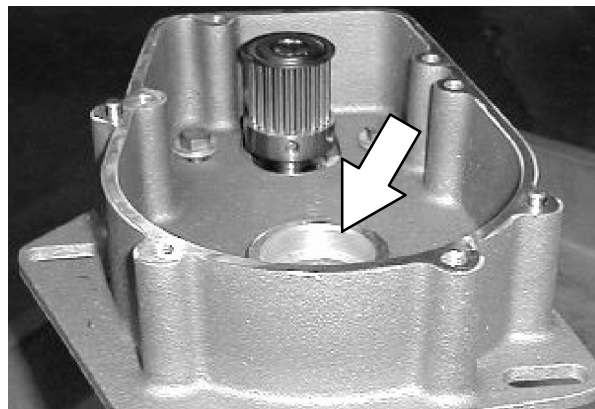

- Position the cogged belt onto the large and small pulleys.

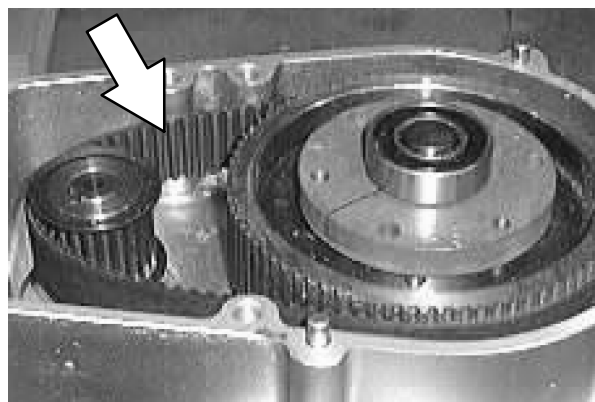

CHASSIS

12. Reinstall the bearing side cover onto the gearbox. Make sure the cover is seated down over the locating pins. Install two hex screws for now. Tighten the screws to 18 - 24 Nm (15 - 20 ft lb).

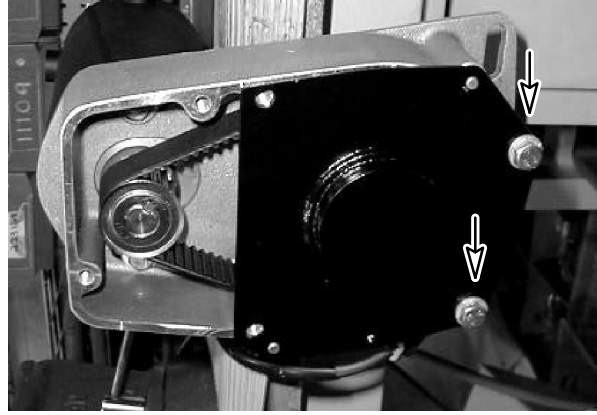

13. Use a large channel lock pliers to pull the drive motor to the front of the gearbox. Place one side of the pliers over the small pulley and the other side of the pliers on the front side of the gearbox. Squeeze the pliers until the belt is tight (*1/16 inch play at midpoint*). Tighten the two motor mount screws to 18 - 24 Nm (15 - 20 ft lb).

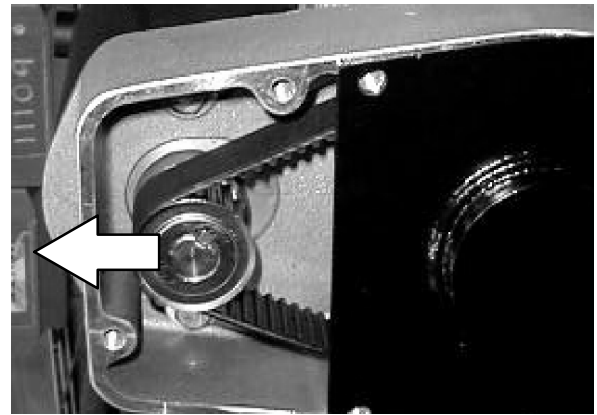

14. Install the second belt cover onto the gearbox. Install the remaining four hex screws and tighten to 18 - 24 Nm (15 - 20 ft lb).

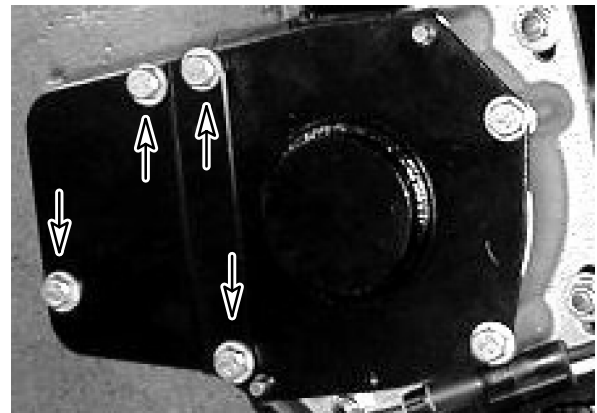

15. Reinstall the gearbox assembly onto the wheel support assembly. See TO INSTALL GEARBOX ASSEMBLY instructions in this section.

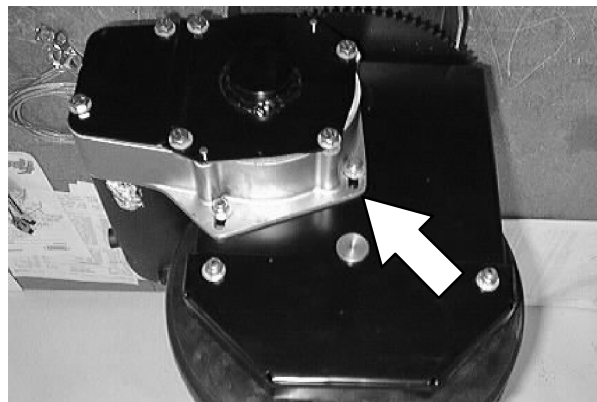

16. Remove the jack stands and lower the machine to the floor. Operate the machine and check the gearbox assembly for proper operation.

TO ADJUST STEERING CHAIN

FOR SAFETY: Before Leaving Or Servicing Machine; Stop On Level Surface, Set Parking Brake.

1. Jack up the front of the machine at the jack point. Install jack stands under the machine frame.

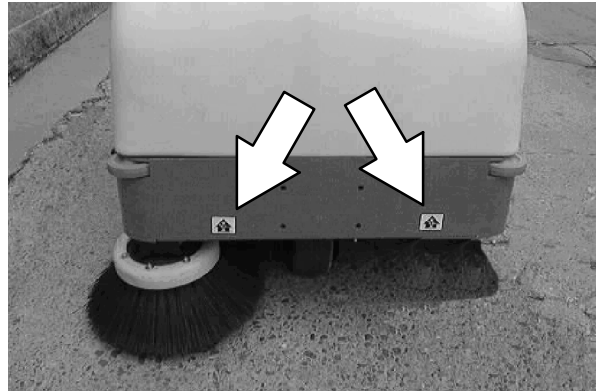

2. Go to the operators compartment and locate the two hex screws holding the steering bearing housing to the machine frame. Loosen the two screws.

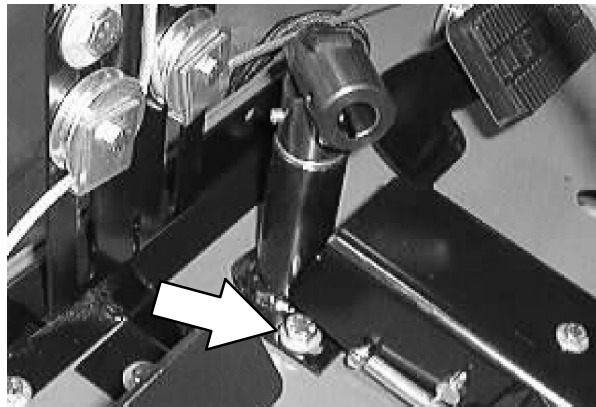

3. Turn the steering wheel all the way to the left and then to the right. Find the point in the rotation where the steering chain is the most tight.



CHASSIS

4. Push the bearing housing forward in the slots. This will remove any excess slack in the steering chain. Tighten the two hex screws to 37 - 48 Nm (26 - 34 ft lb).

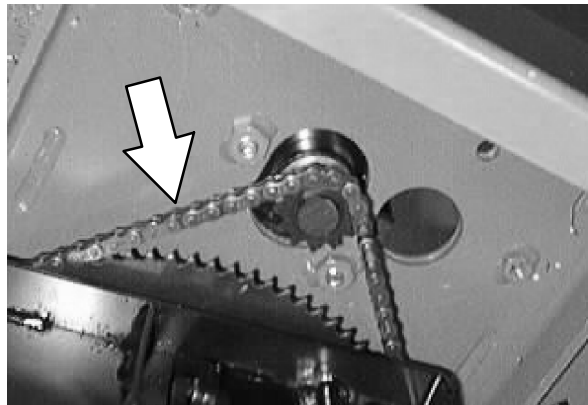

5. Remove the jack stands and lower the machine to the floor. Operate the machine and check the steering chain for proper operation.

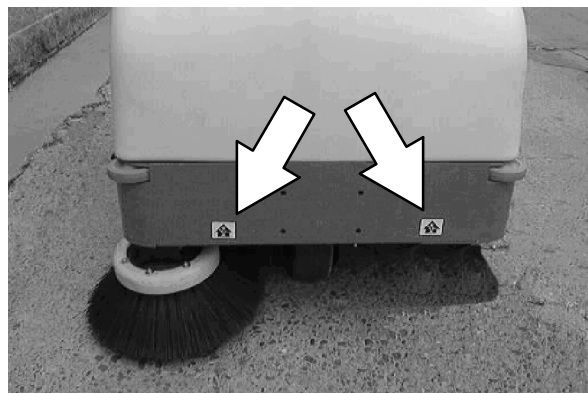

TO REPLACE STEERING CHAIN

FOR SAFETY: Before Leaving Or Servicing Machine; Stop On Level Surface, place blocks in front and back of the rear tires.

1. Jack up the front of the machine at the jack point. Install jack stands under the machine frame.

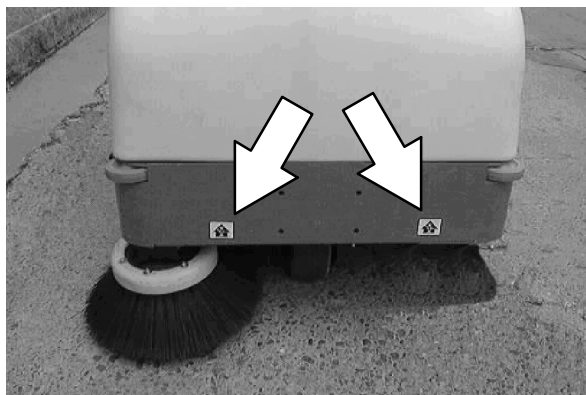

2. Turn the steering wheel all the way to the left.

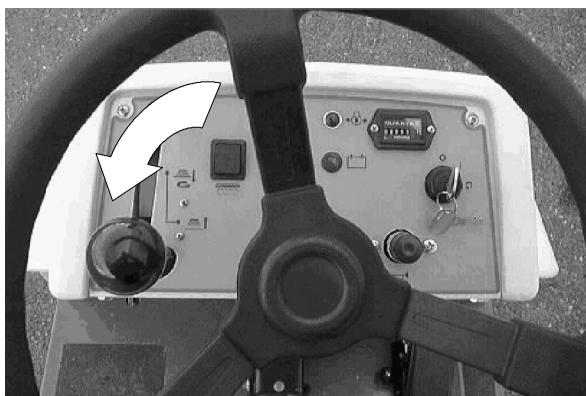

3. Go to the operators compartment and locate the two hex screws holding the steering bearing housing to the machine frame. Loosen the two screws and push the bearing housing back in the slots.

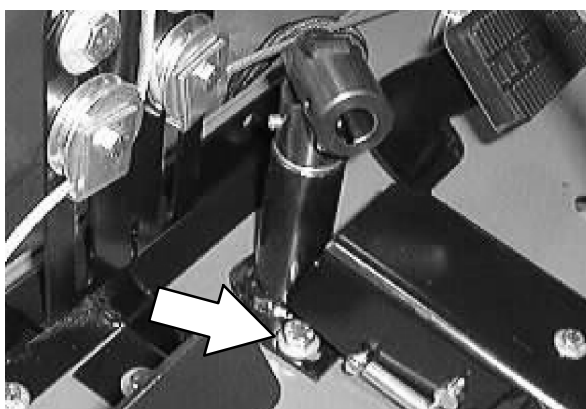

CHASSIS

4. Go under the machine and locate the small steering chain sprocket.

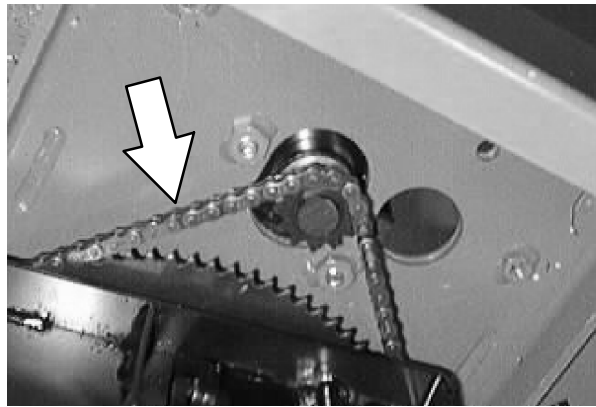

5. Locate the master link on the steering chain. Remove the master link and steering chain.

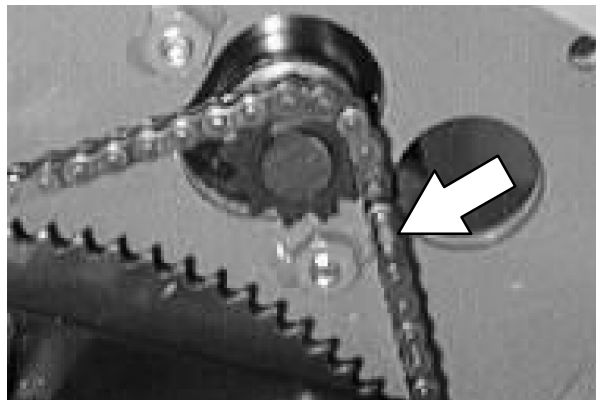

6. Position the new steering chain around both the large steering sprocket and small sprocket. Install a new master link in the new chain.

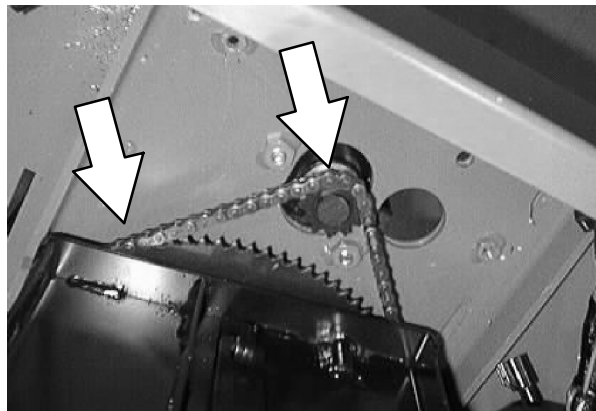

7. Turn the steering wheel all the way to the left and then to the right. Find the point in the rotation where the steering chain is the most tight.

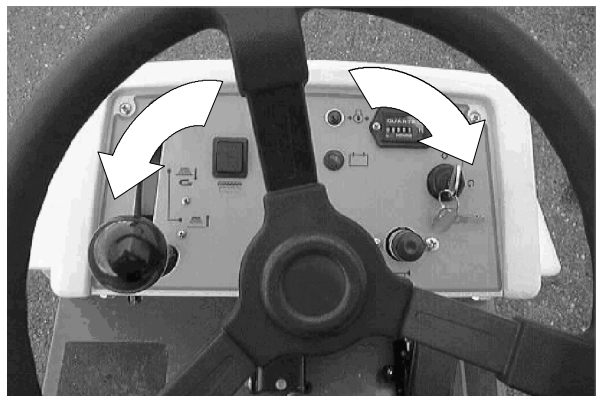

8. Push the bearing housing forward in the slots. This will remove any excess slack in the steering chain. Tighten the two hex screws to 37 - 48 Nm (26 - 34 ft lb).

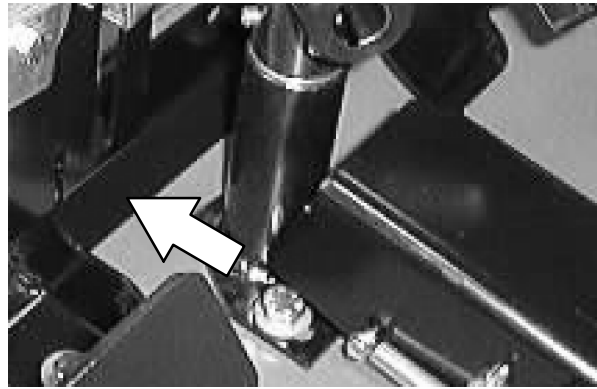

9. Remove the jack stands and lower the machine to the floor. Operate the machine and check the steering chain for proper operation.

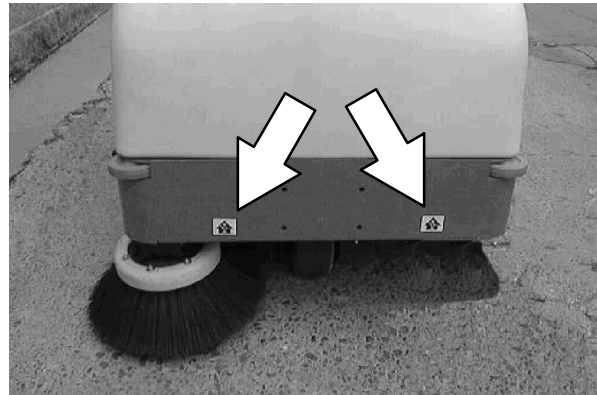

TO REPLACE STEERING HOUSING BEARINGS

FOR SAFETY: Before Leaving Or Servicing Machine; Stop On Level Surface, Set Parking Brake.

1. Jack up the front of the machine at the jack point. Install jack stands under the machine frame.

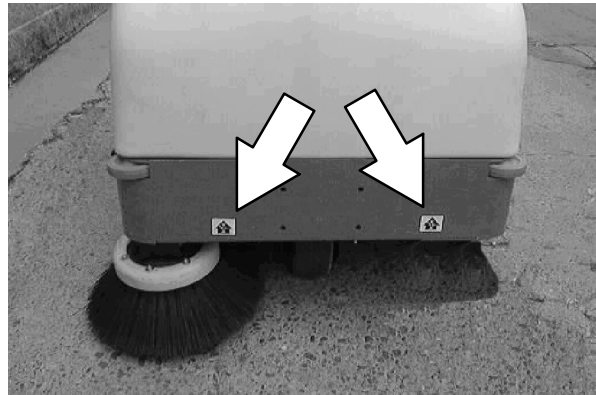

2. Turn the steering wheel all the way to the left.

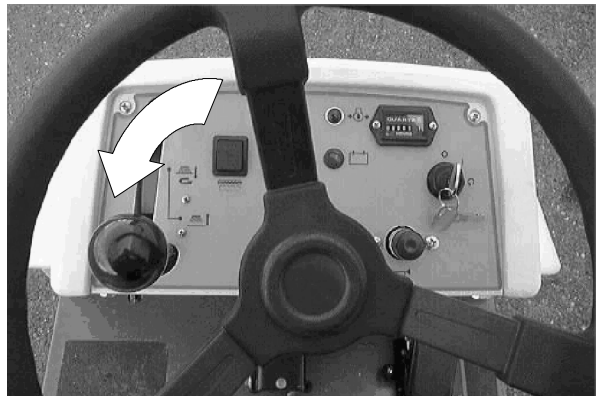

3. Go to the operators compartment and locate the steering U-joint. Loosen the two set screws on the top of the steering U-joint.

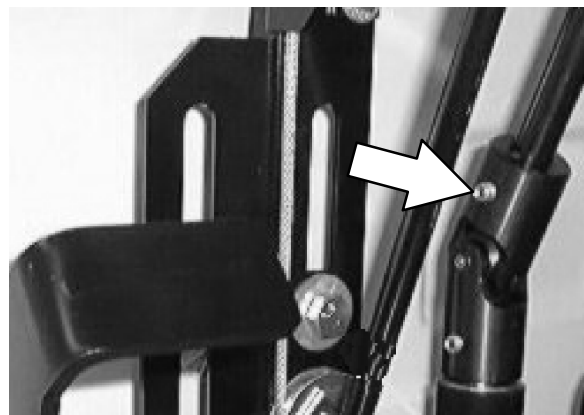

4. Pull the steering wheel and long steering shaft up and out of the top of the steering U-joint.

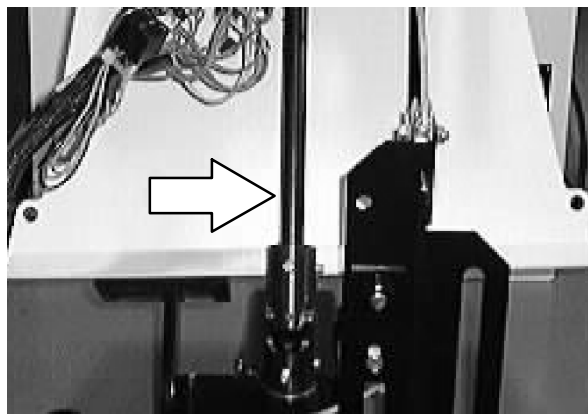

5. Remove the two hex screws holding the steering bearing housing to the machine frame. Push the bearing housing back in the slots.

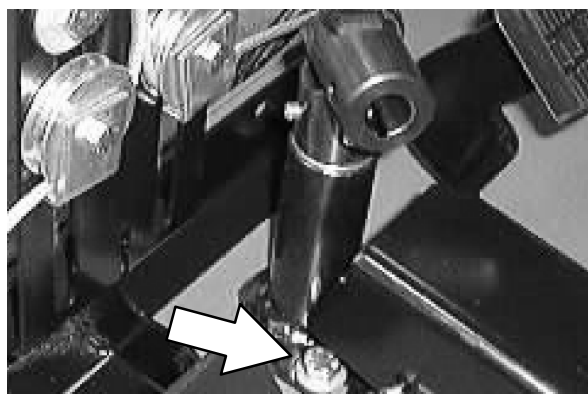

6. Go under the machine and locate the small steering chain sprocket.

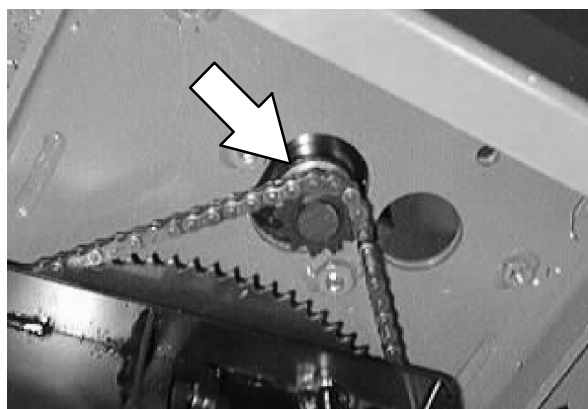

7. Locate the master link on the steering chain. Remove the master link and steering chain from the small steering sprocket.

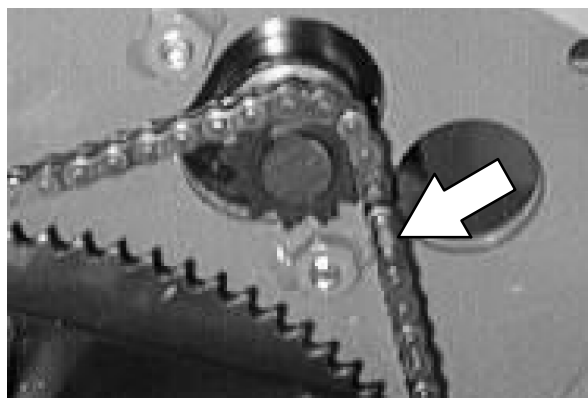

CHASSIS

8. Remove the steering housing from the machine.

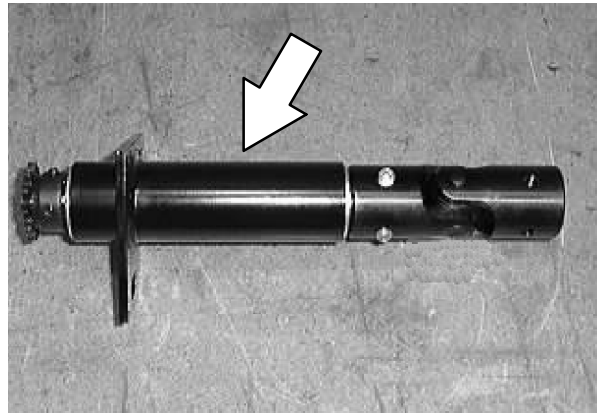

9. Loosen the two set screws holding the U-joint to the top of the short steering shaft. Remove and retain the U-joint and square key.

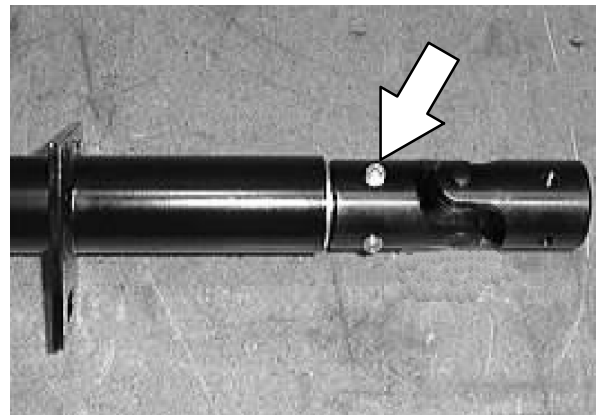

10. Loosen the set screw holding the small steering sprocket to the bottom of the short steering shaft. Remove and retain small sprocket and woodruff key.

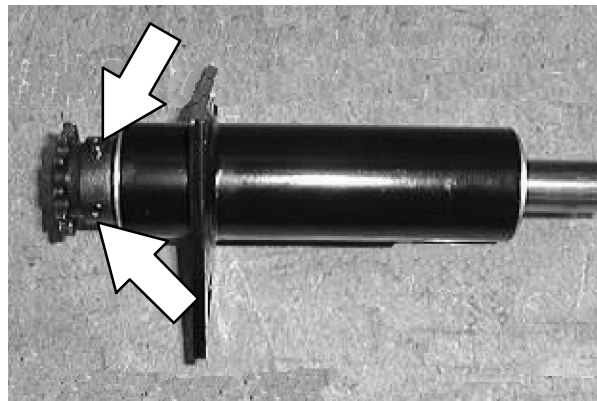

11. Use an arbor press to press the short steering shaft and two bearings out of the housing. Discard the bearings. Retain the short shaft. *Note the orientation of the shaft in the housing.*

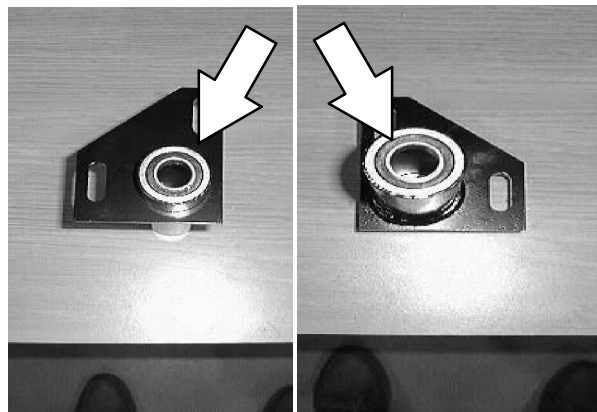

12. Use the arbor press to install the new bearings into the steering housing.

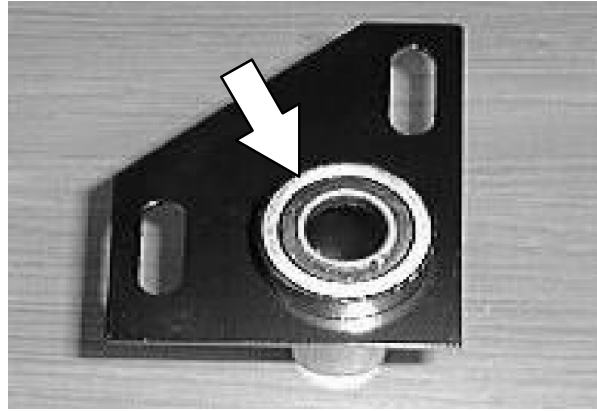

13. Use the arbor press to install the short steering shaft into the new bearings.



14. Reinstall the small steering sprocket and woodruff key on the bottom of the steering housing. Tighten the set screws tight.

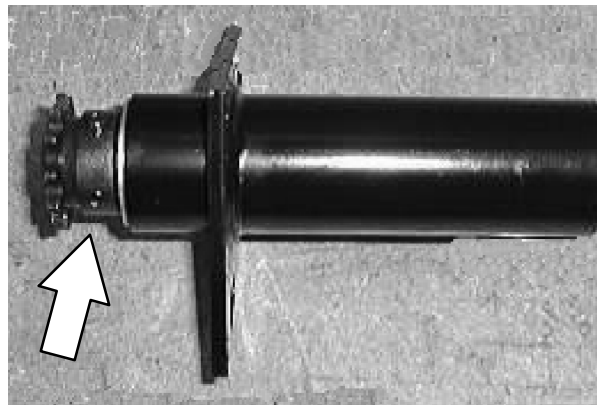

15. Reinstall the U-joint and square key on the top of the steering housing. Tighten the set screws tight.

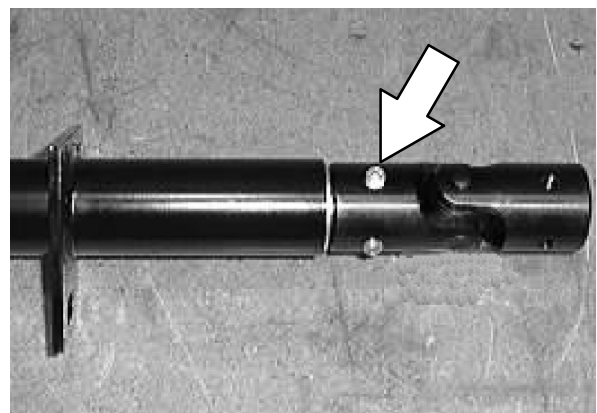

CHASSIS

16. Reinstall the steering housing in the machine. Reinstall the two hex screws. Leave loose for now.

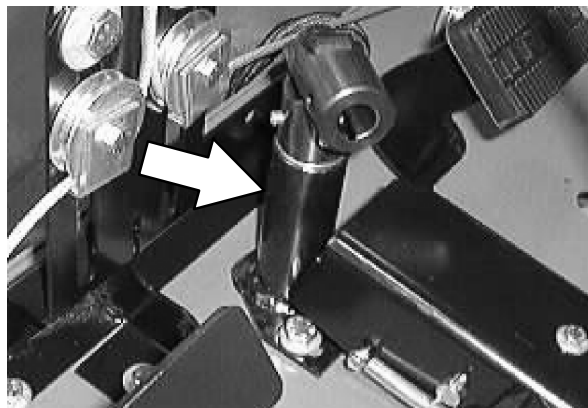

17. Position the long steering shaft and steering wheel into the top of the steering U-joint. Tighten the set screws tight.

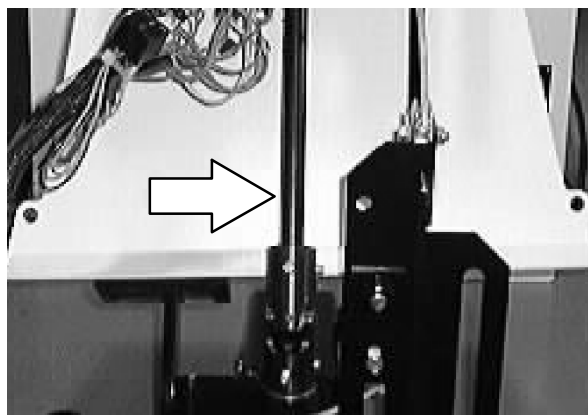

18. Go under the machine and reinstall the steering chain around the small steering sprocket. Reinstall the master link.

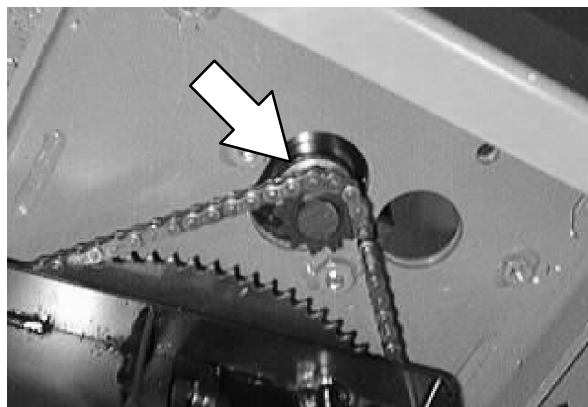

19. Turn the steering wheel all the way to the left and then to the right. Find the point in the rotation where the steering chain is the most tight.

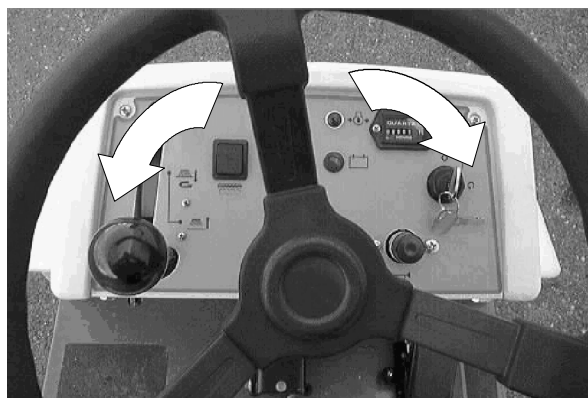

20. Push the bearing housing forward in the slots. This will remove any excess slack in the steering chain. Tighten the two hex screws to 37 - 48 Nm (26 - 34 ft lb).

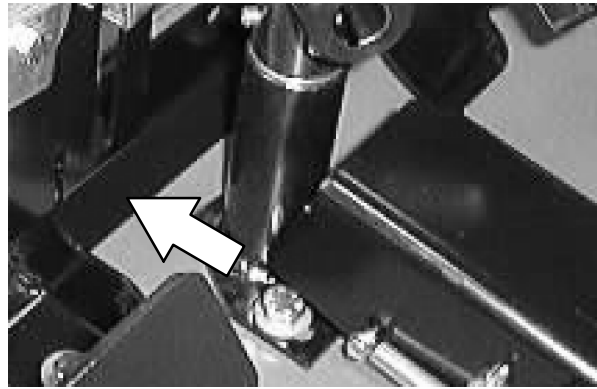

21. Remove the jack stands and lower the machine to the floor. Operate the machine and check the steering chain for proper operation.

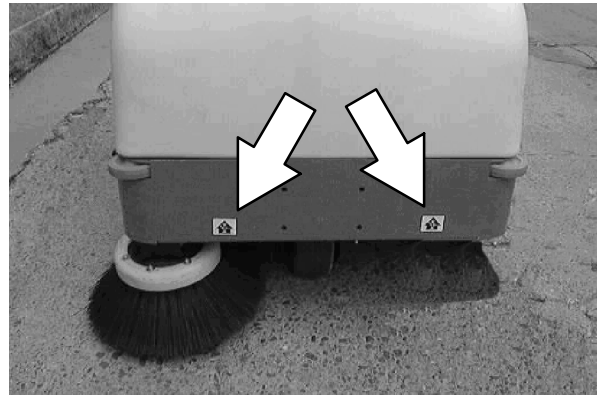

CHASSIS

TO REPLACE STEERING U-JOINT

FOR SAFETY: Before Leaving Or Servicing Machine; Stop On Level Surface, Set Parking Brake.

1. Jack up the front of the machine at the jack point. Install jack stands under the machine frame.

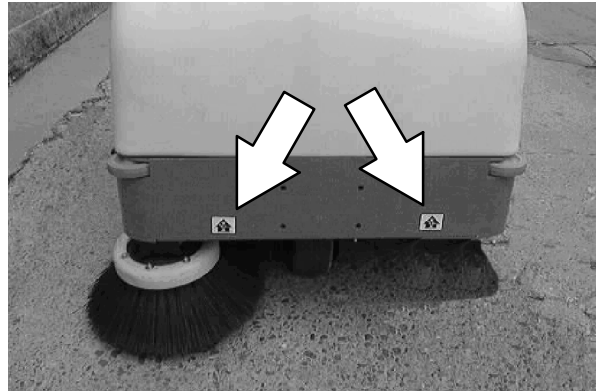

2. Go to the operators compartment and locate the steering U-joint. Loosen the two set screws on the top of the steering U-joint.

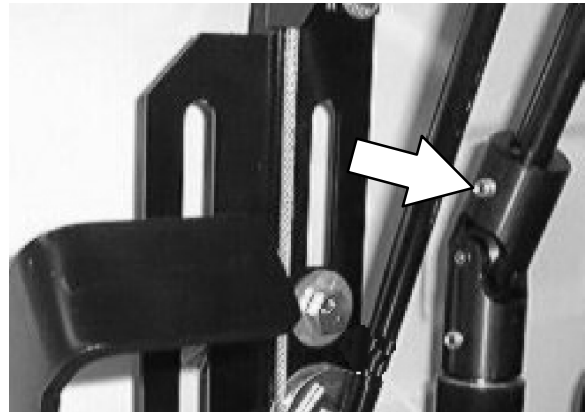

3. Pull the steering wheel and long steering shaft up and out of the top of the steering U-joint.

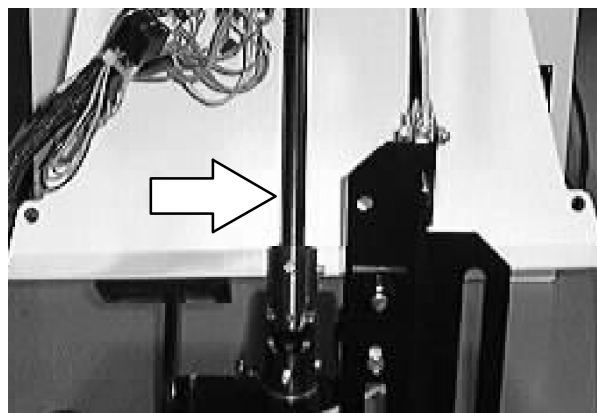

- Loosen the two set screws holding the U-joint to the top of the short steering shaft. Remove and discard the U-joint and square key.

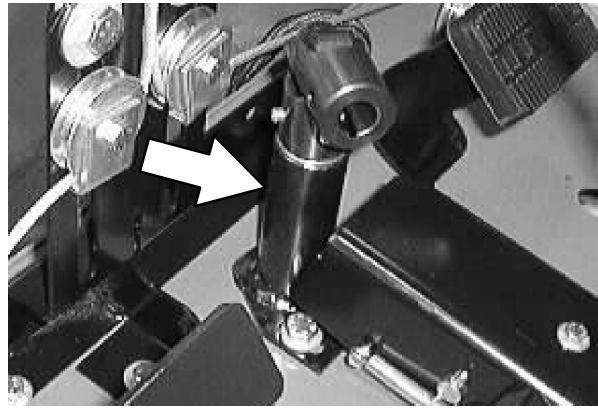

- Install the new U-joint and square key on the top of the steering housing. Tighten the set screws tight.

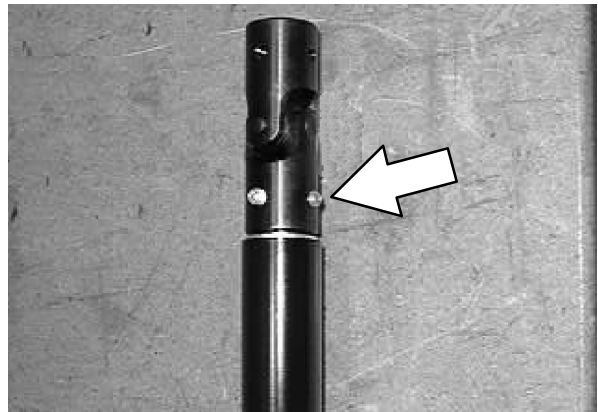

- Position the long steering shaft and steering wheel into the top of the steering U-joint. Tighten the set screws tight.

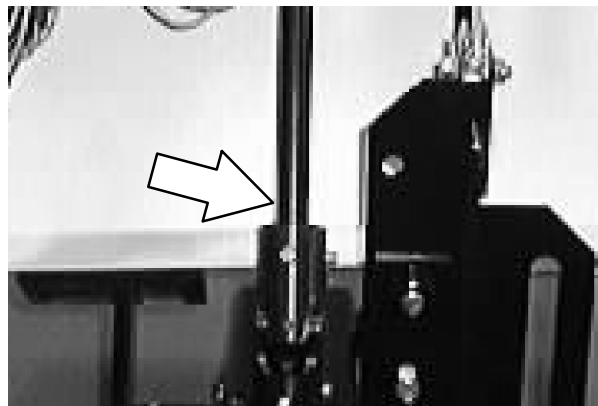

- Operate the machine and check the steering U-joint for proper operation.

CHASSIS

TO REPLACE SMALL STEERING SPROCKET

FOR SAFETY: Before Leaving Or Servicing Machine; Stop On Level Surface, Set Parking Brake.

1. Jack up the front of the machine at the jack point. Install jack stands under the machine frame.

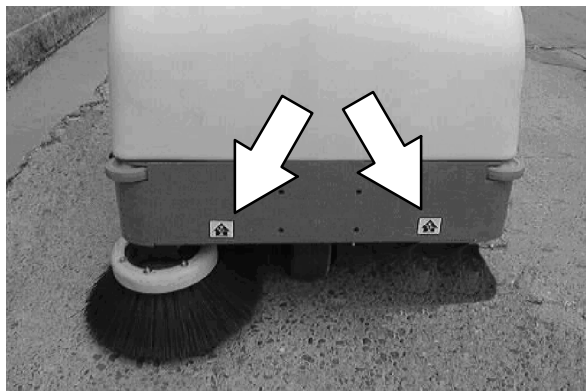

2. Turn the steering wheel all the way to the left.

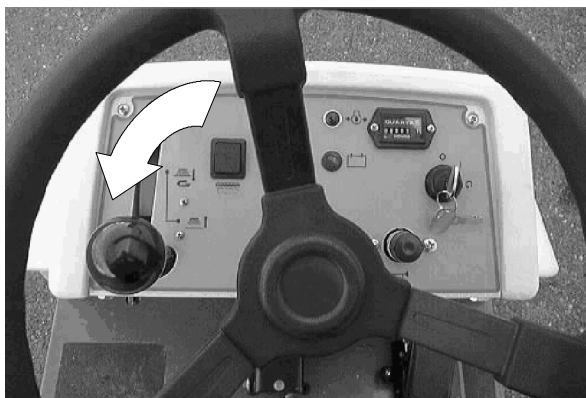

3. Go to the operators compartment and locate the two hex screws holding the steering bearing housing to the machine frame. Loosen the two screws and push the bearing housing back in the slots. *This will loosen the steering chain.*

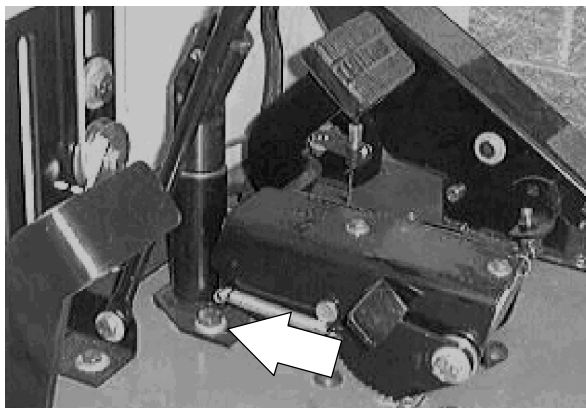

4. Go under the machine and locate the small steering chain sprocket.

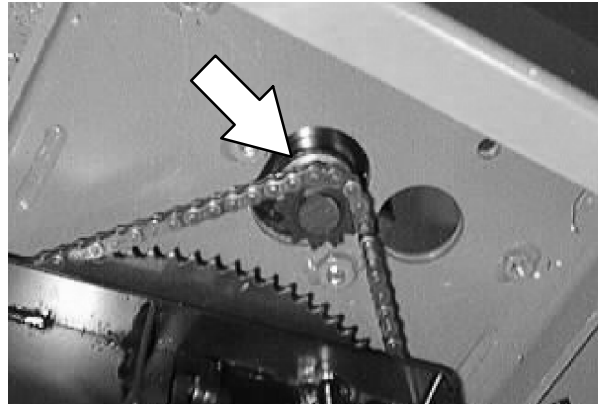

5. Locate the master link on the steering chain. Remove the master link from the steering chain.

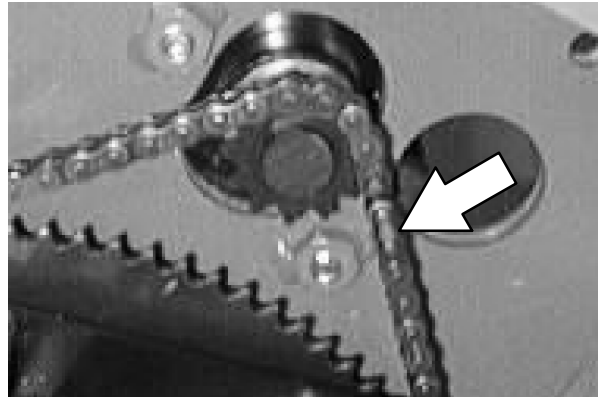

6. Loosen the set screw holding the small steering sprocket to the bottom of the short steering shaft. Remove and discard the small sprocket. Retain the woodruff key.

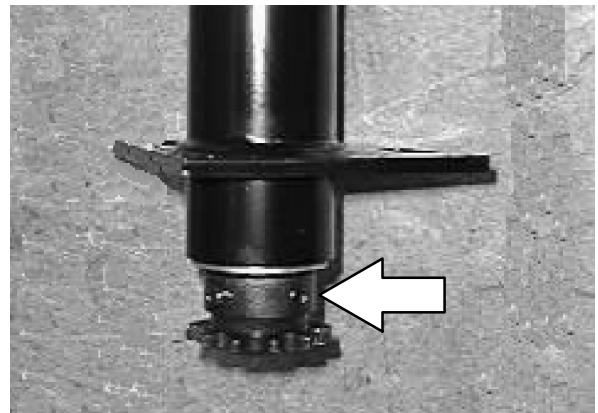

7. Install the new small sprocket and woodruff key onto the steering shaft. The teeth of the new sprocket face down. Position the sprocket in the same location as the old one. Tighten the two set screws tight.

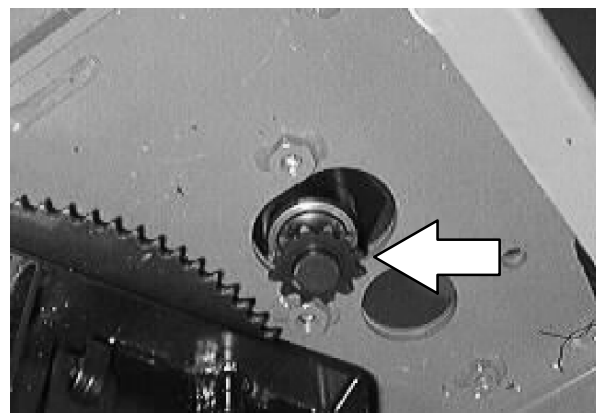

CHASSIS

- Place the steering chain around the new sprocket. Reinstall the master link.

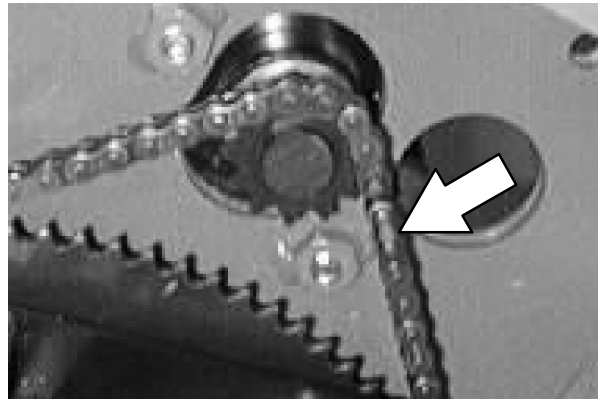

- Turn the steering wheel all the way to the left and then to the right. Find the point in the rotation where the steering chain is the most tight.

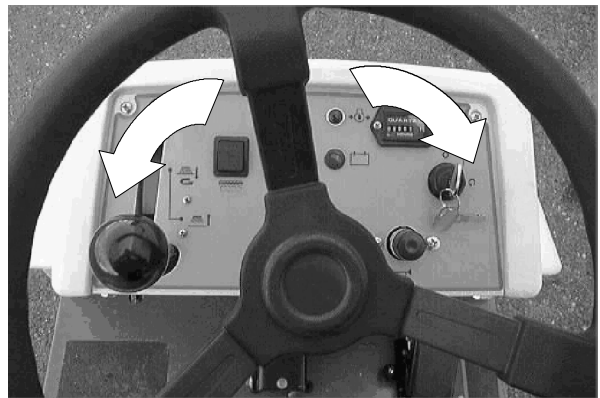

- Push the bearing housing forward in the slots. This will remove any excess slack in the steering chain. Tighten the two hex screws to 37 - 48 Nm (26 - 34 ft lb).

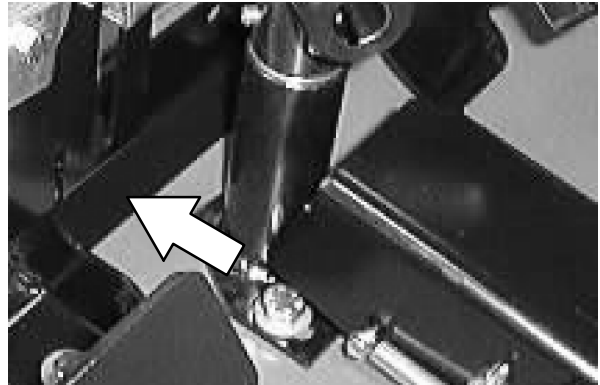

- Remove the jack stands and lower the machine to the floor. Operate the machine and check the steering for proper operation.

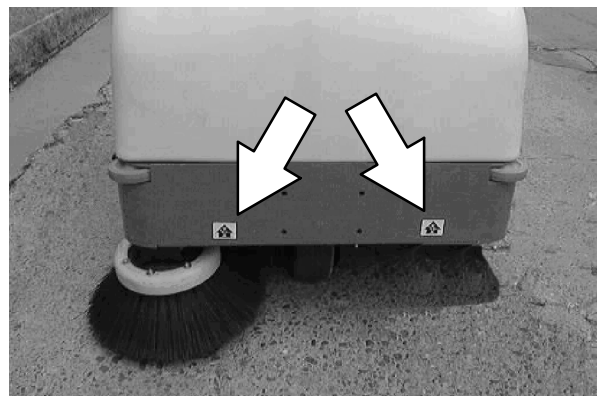

TO REPLACE LARGE STEERING SPROCKET

FOR SAFETY: Before Leaving Or Servicing Machine; Stop On Level Surface, place blocks in front and back of the rear tires.

1. Jack up the front of the machine at the jack point. Install jack stands under the machine frame.

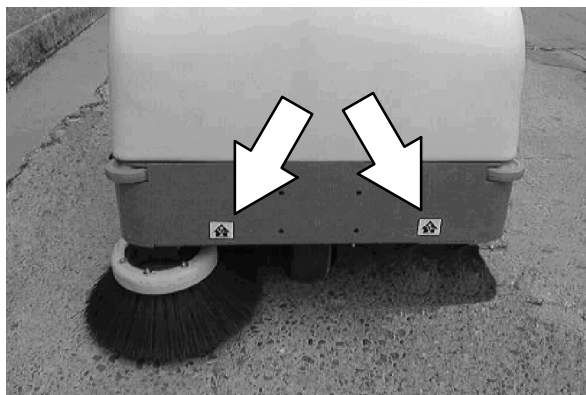

2. Turn the steering wheel all the way to the left.

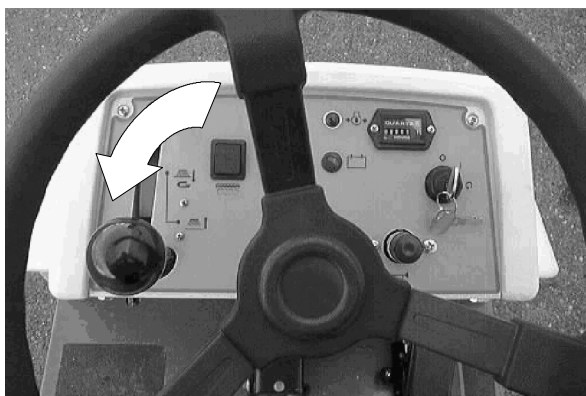

3. Go to the operators compartment and locate the two hex screws holding the steering bearing housing to the machine frame. Loosen the two screws and push the bearing housing back in the slots. *This will loosen the steering chain.*

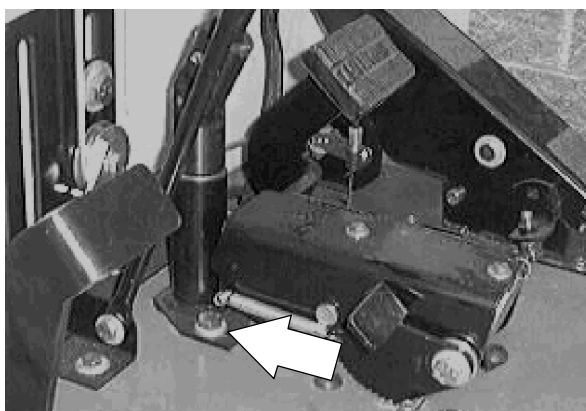

CHASSIS

4. Locate the master link on the steering chain. Remove the master link from the steering chain. Remove the steering chain from the machine.

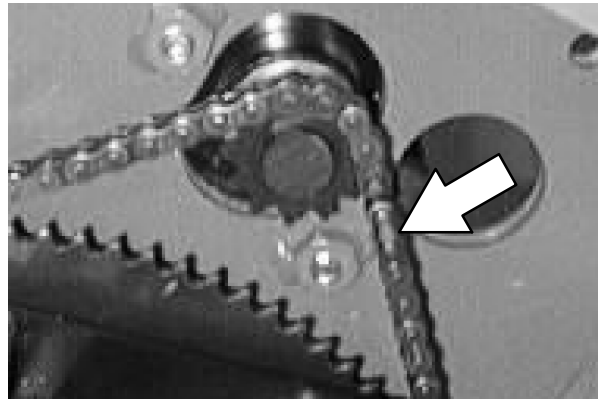

5. Remove the front tire assembly. See TO REMOVE FRONT TIRE AND WHEEL instructions in this section.

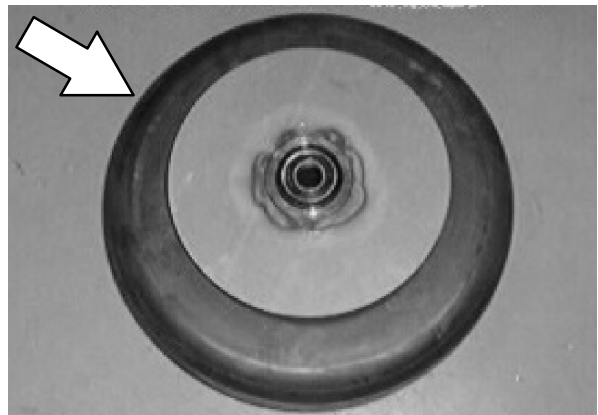

6. Go under the machine and locate the short brake rod coming through the center of the wheel support bearing assembly. Disconnect the clevis end of the short brake cable where it attaches to the brake lever.

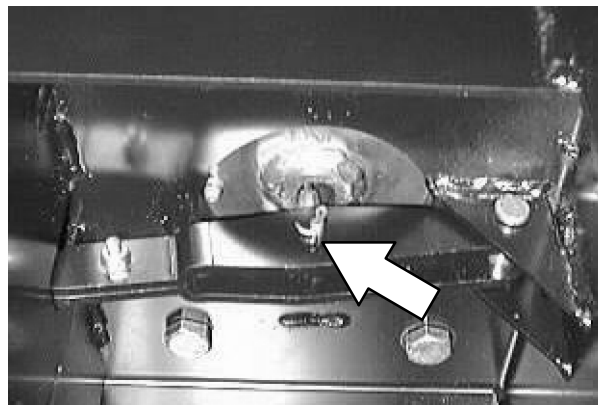

7. Remove the four hex screws holding the wheel support and large sprocket to the pivot bearing assembly. Drop the wheel support and large sprocket out of the machine.

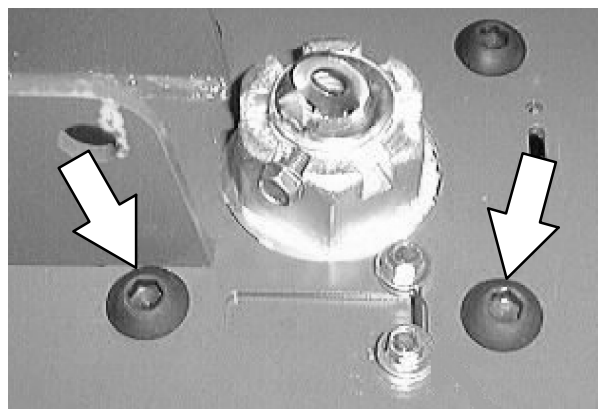

8. Remove the large sprocket from the wheel support. Discard the sprocket.

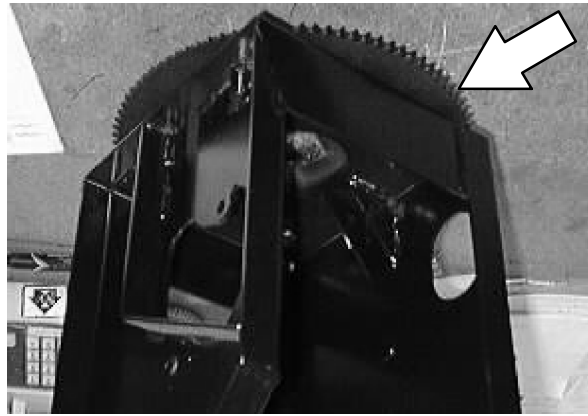

9. Position the new large steering sprocket onto the wheel support. Make sure the locating pin on the wheel support is inserted in the locating pin hole in the new sprocket.

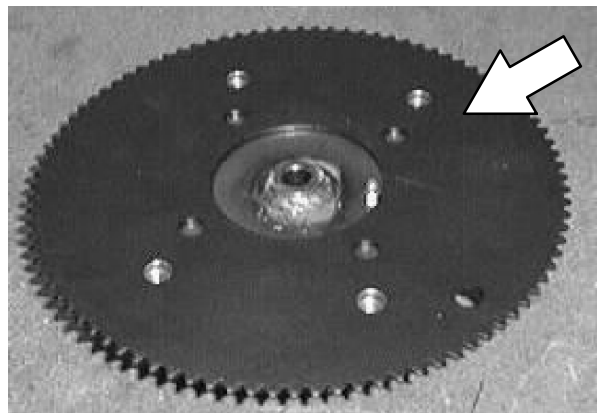

10. Position the wheel support and sprocket assembly into the machine. Line up the mount holes in the wheel support and sprocket with the threaded holes in the bottom of the pivot bearing assembly. Reinstall the four screws and tighten to 64 - 83 Nm (47 - 61 ft lb).

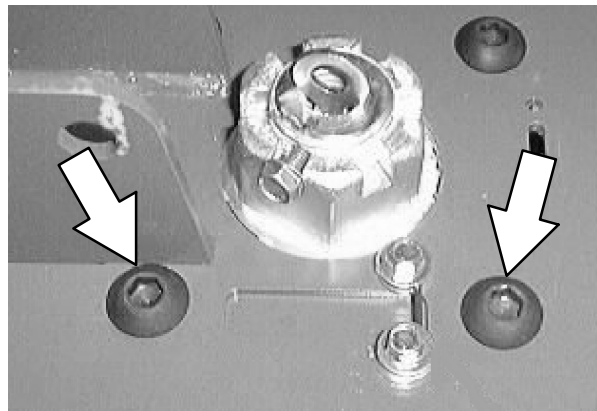

11. Reconnect the short brake rod to the brake lever.

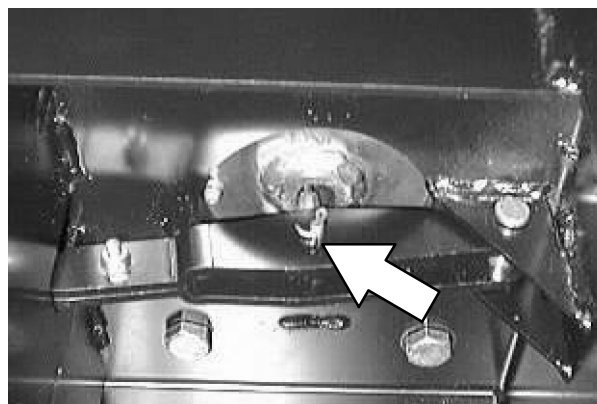

CHASSIS

12. Reinstall the front wheel assembly. See TO INSTALL FRONT TIRE AND WHEEL instructions in this section.

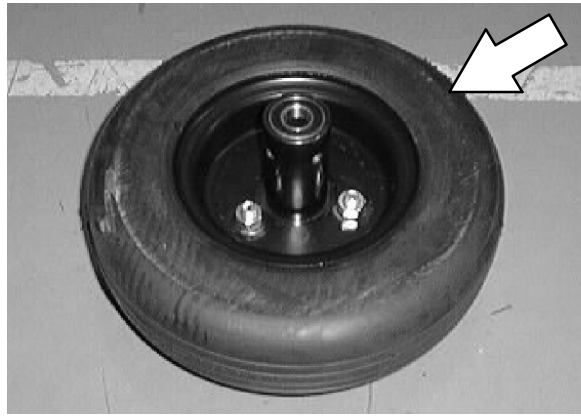

13. Reinstall the steering chain onto both steering sprockets. Reinstall the master link.

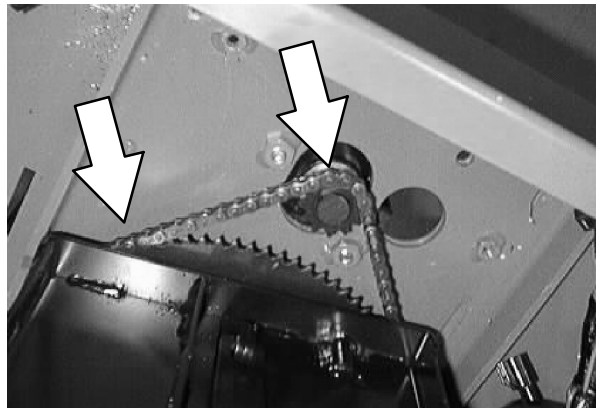

14. Turn the steering wheel all the way to the left and then to the right. Find the point in the rotation where the steering chain is the most tight.

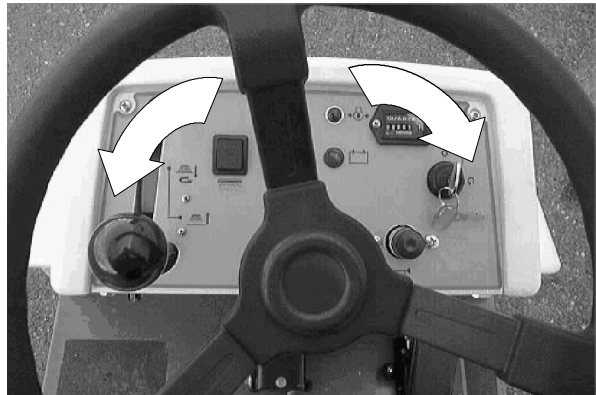

15. Push the bearing housing forward in the slots. This will remove any excess slack in the steering chain. Tighten the two hex screws to 37 - 48 Nm (26 - 34 ft lb).

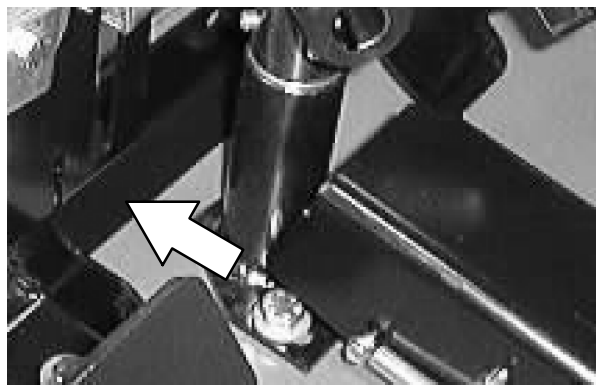

16. Remove the jack stands and lower the machine to the floor. Operate the machine and check the steering for proper operation.

**TO REPLACE FRONT WHEEL HOUSING
NEEDLE BEARING/THRUST WASHERS**

FOR SAFETY: Before Leaving Or Servicing Machine; Stop On Level Surface, place blocks in front and back of the rear tires.

1. Jack up the front of the machine at the jack point. Install jack stands under the machine frame.

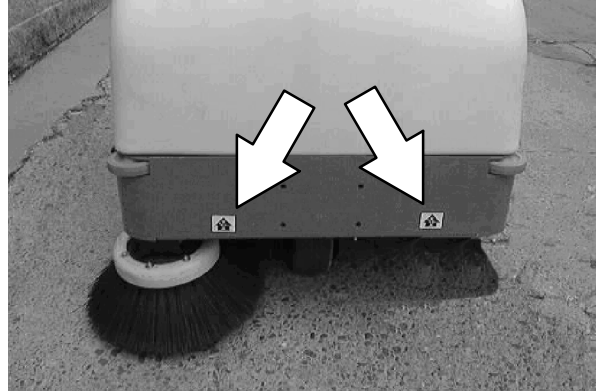

2. Turn the steering wheel all the way to the left.

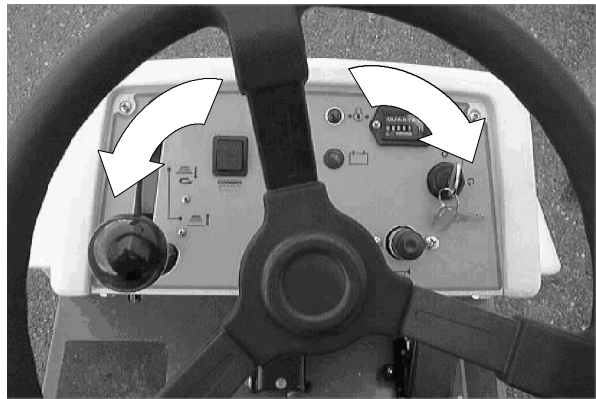

3. Go to the operators compartment and locate the two hex screws holding the steering bearing housing to the machine frame. Loosen the two screws and push the bearing housing back in the slots. *This will loosen the steering chain.*

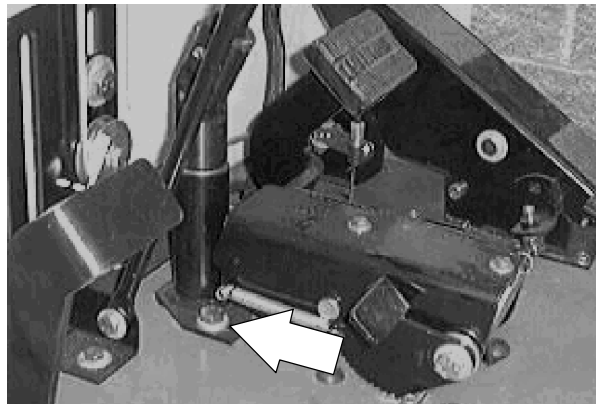

CHASSIS

4. Locate the master link on the steering chain. Remove the master link from the steering chain. Remove the steering chain from the machine.

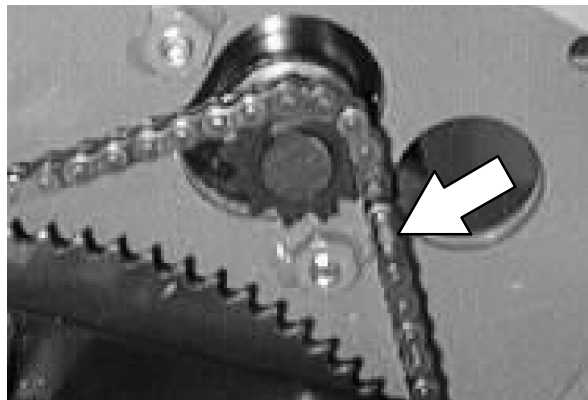

5. Disconnect the drive motor from the main harness.

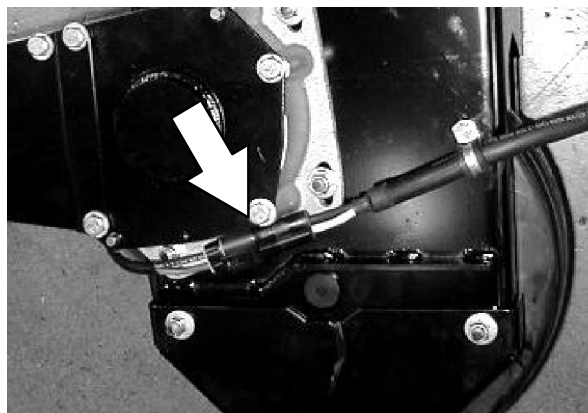

6. Go to the operators compartment and locate the clevis pin holding the brake pedal assembly to the floor plate. Remove the clevis pin and tension spring from the brake pedal.

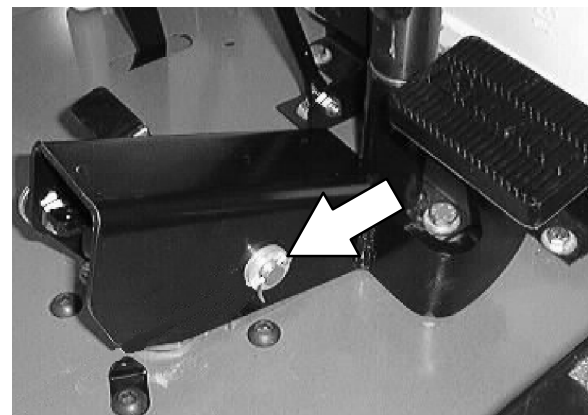

7. Pull the brake pedal up and disconnect the clevis end of the short brake rod where it attaches to the brake pedal assembly.

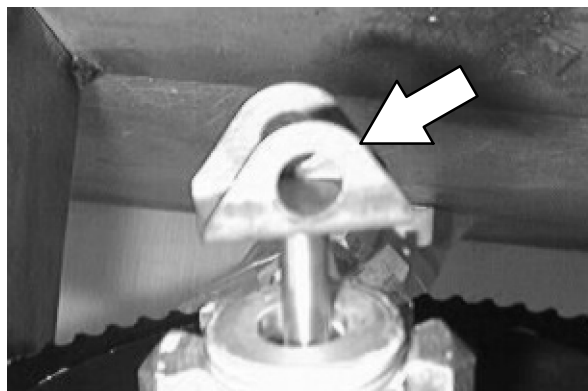

8. Support the front drive assembly with a jack or blocks. Remove the four button head screws holding the front drive assembly in the machine. Lower the drive assembly down and out of the machine.

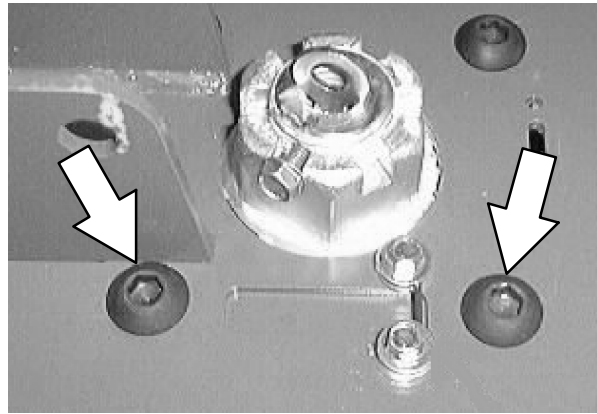

9. Remove the small thread roller screw holding the castle nut to the pivot shaft. Remove the castle nut and flat washer.

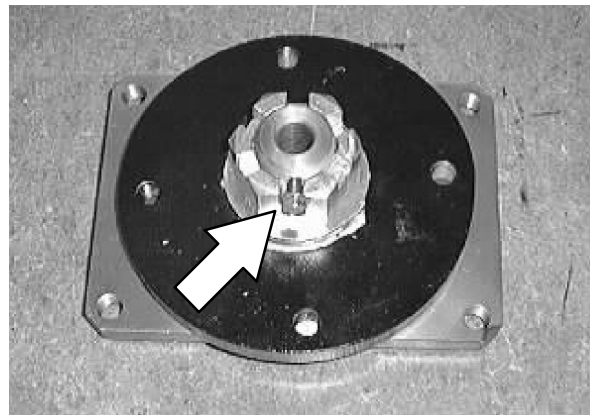

10. Pull the cone bearing out of the swivel plate.

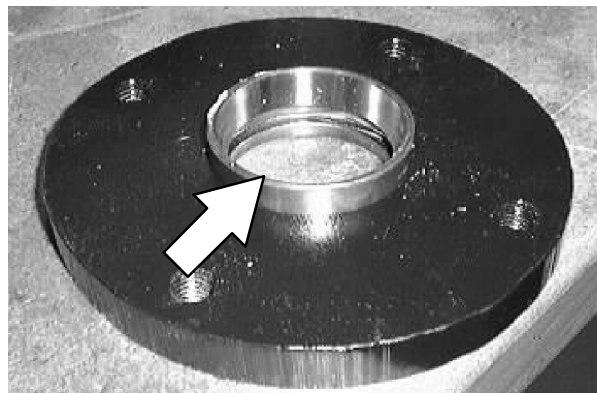

11. Pull the swivel plate off the swivel plate weldment. Make sure to retain the rubber seal ring.

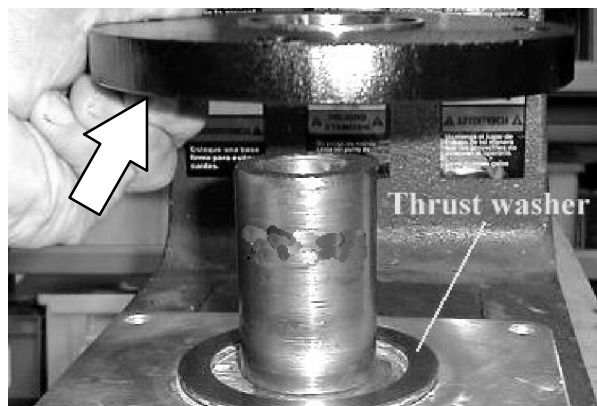

CHASSIS

12. Remove and discard the upper thrust washer. Remove and discard the needle bearing and lower thrust washer.
13. Install the new thrust washer onto the swivel plate weldment.
14. Grease the new needle bearing and position on top of the new thrust washer. Install the second thrust washer on top of the needle bearing.

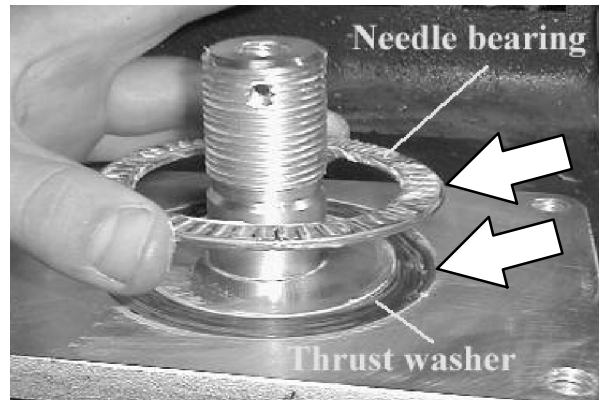

15. Reinstall the swivel plate onto the swivel plate weldment. **Make sure the rubber seal ring is in place on the swivel plate before installing.**

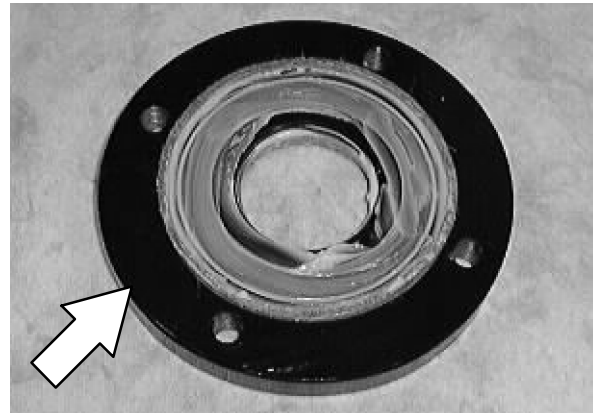

16. Reinstall the cone bearing in the swivel plate. *Grease the bearing if needed.*

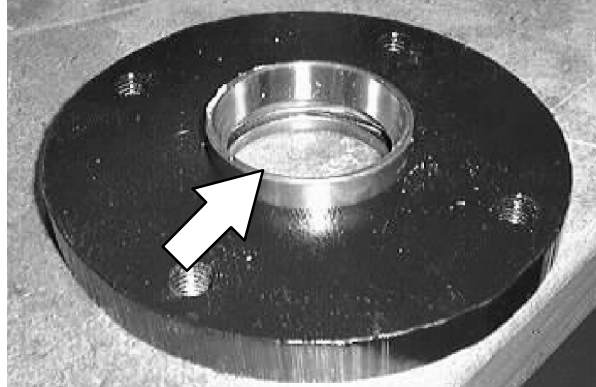

17. Reinstall the large flat washer and castle nut. Tighten to 37 - 48 Nm (26 - 34 ft. lb). Reinstall the small thread roller into the cross hole. *Back off the castle nut if needed to align cross hole.*

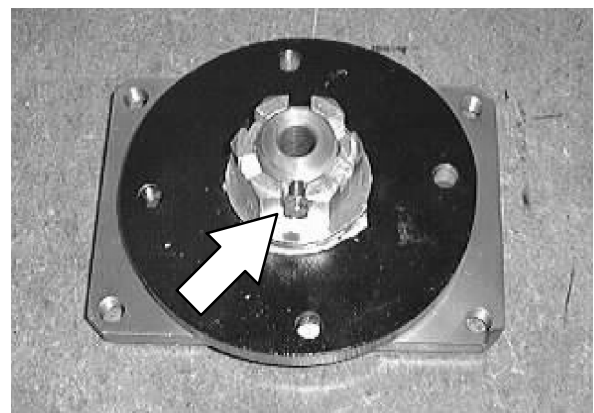

18. Use a floor jack to reinstall the front drive assembly in the machine.

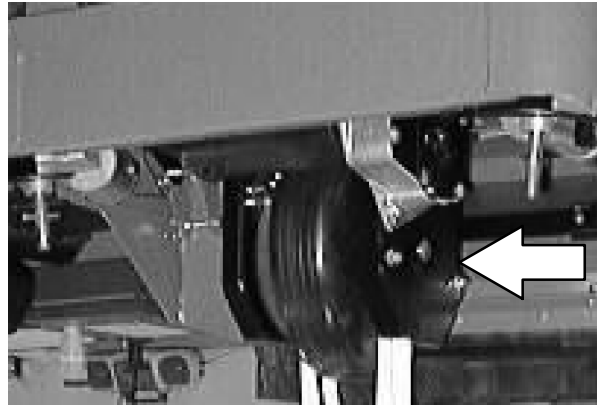

19. Line up the four threaded holes in the swivel plate weldment with the mount holes in the machine frame. Reinstall the four button head screws and tighten to 64 - 83 Nm (47 - 61 ft lb). *Make sure the drive motor is facing the front of the machine.*

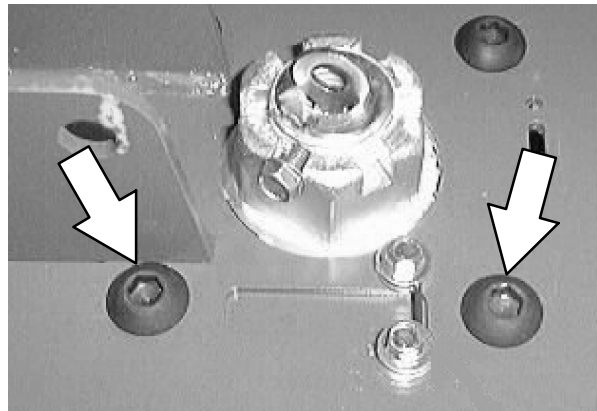

20. Reinstall the steering chain onto both steering sprockets. Reinstall the master link.

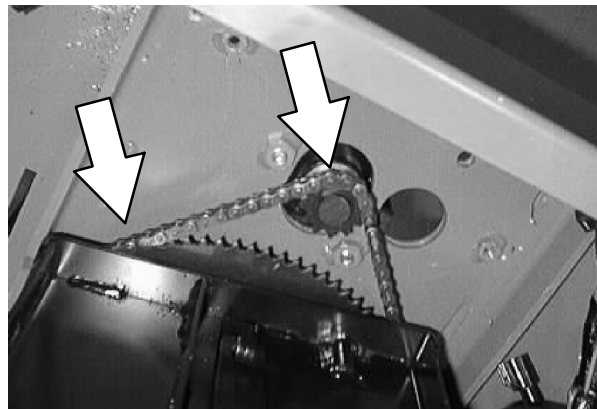

21. Go back to the operators compartment. Push the steering housing forward in the slots. This will remove any slack in the steering chain. Tighten the two hex screws to 37 - 48 Nm (26 - 34 ft lb).

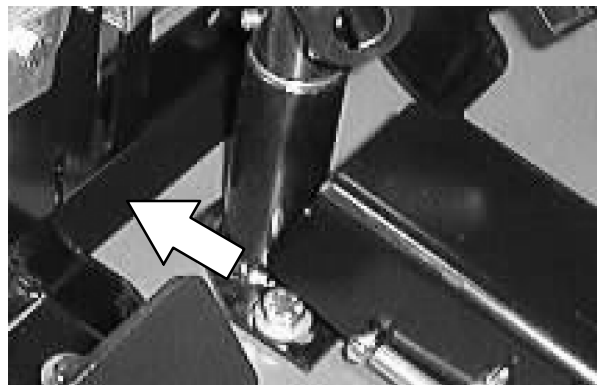

CHASSIS

22. Reconnect the drive motor to the main harness.

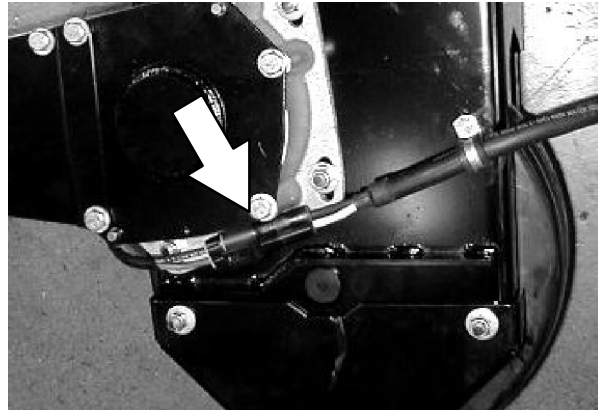

23. Reconnect the short brake rod to the brake pedal.

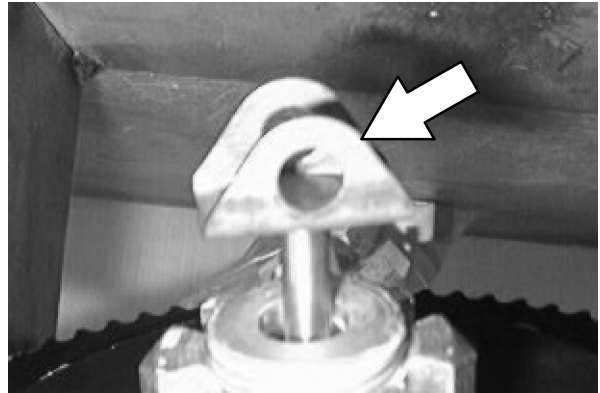

24. Reinstall the brake pedal and clevis pin.

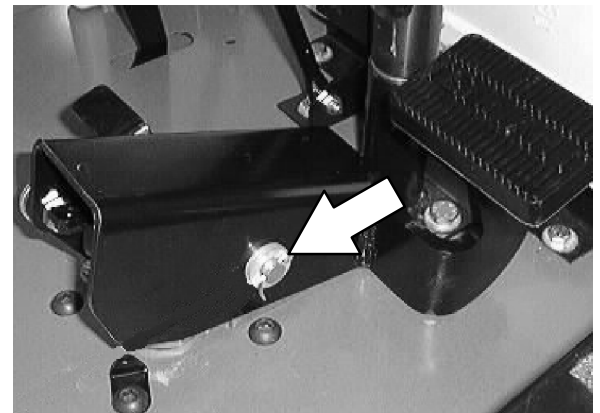

25. Remove the jack stands and lower the machine to the floor. Operate the machine and check the steering for proper operation.

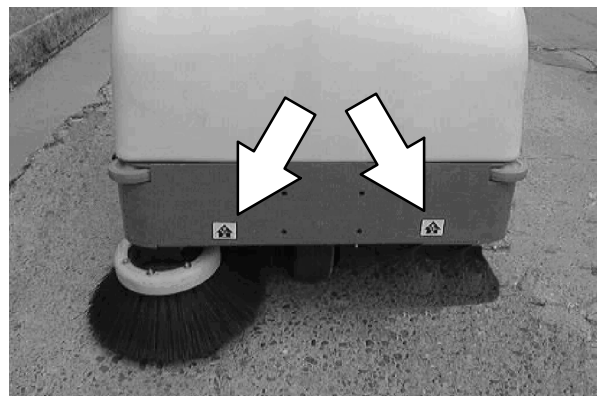

**TO REPLACE FRONT WHEEL HOUSING
CONE BEARING**

FOR SAFETY: Before Leaving Or Servicing Machine; Stop On Level Surface, place blocks in front and back of the rear tires.

1. Jack up the front of the machine at the jack point. Install jack stands under the machine frame.

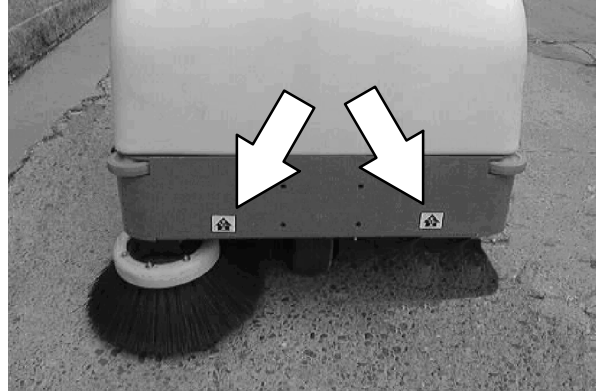

2. Turn the steering wheel all the way to the left.

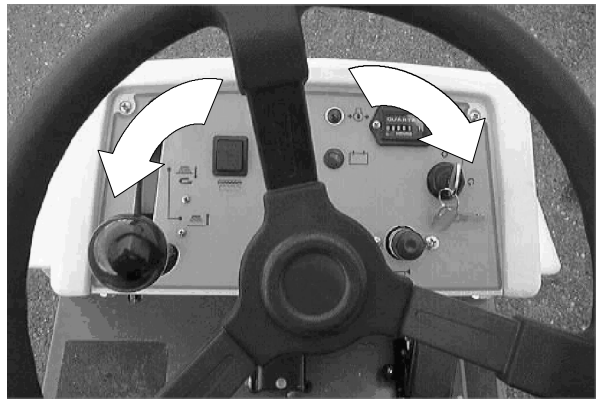

3. Go to the operators compartment and locate the two hex screws holding the steering bearing housing to the machine frame. Loosen the two screws and push the bearing housing back in the slots. *This will loosen the steering chain.*

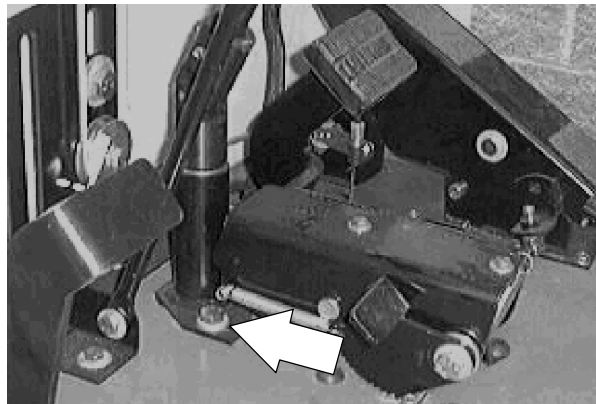

CHASSIS

4. Locate the master link on the steering chain. Remove the master link from the steering chain. Remove the steering chain from the machine.

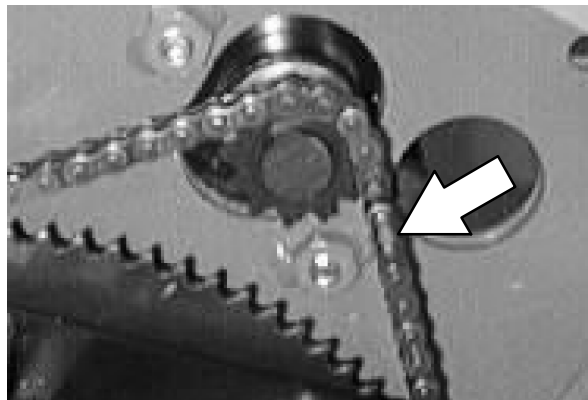

5. Disconnect the drive motor from the main harness.

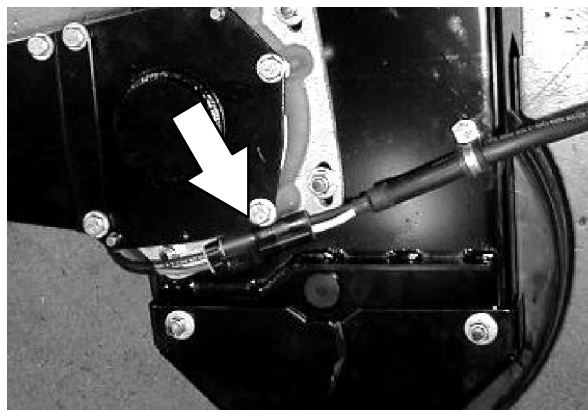

6. Go to the operators compartment and locate the clevis pin holding the brake pedal assembly to the floor plate. Remove the clevis pin and tension spring from the brake pedal.

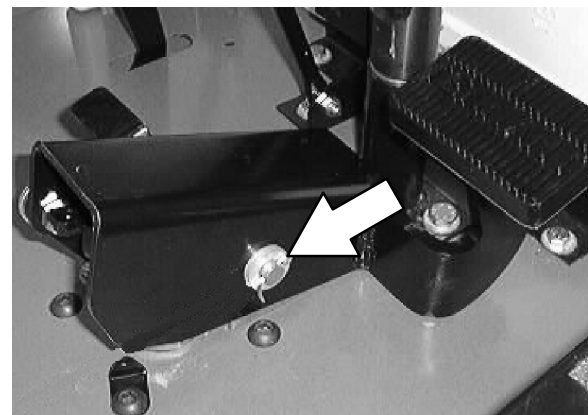

7. Pull the brake pedal up and disconnect the clevis end of the short brake rod where it attaches to the brake pedal assembly.

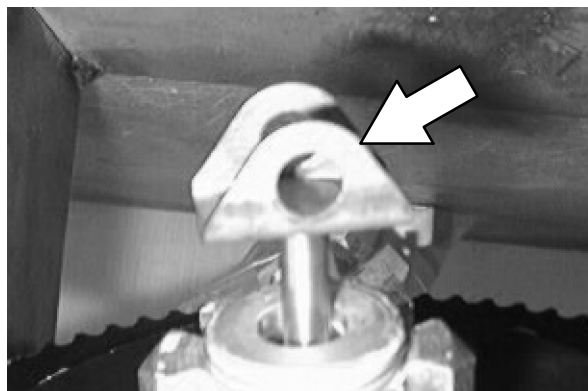

- Support the front drive assembly with a jack or blocks. Remove the four button head screws holding the front drive assembly in the machine. Lower the drive assembly down and out of the machine.

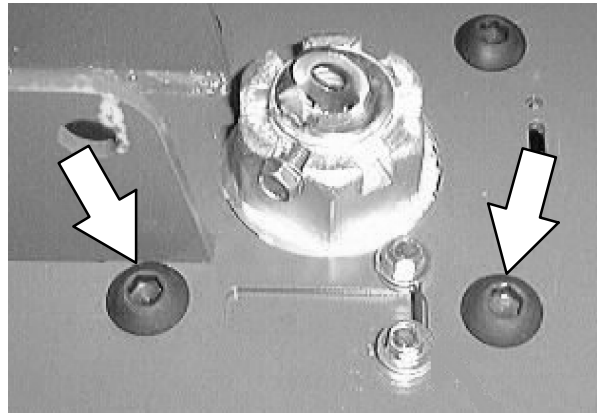

- Remove the small thread roller screw holding the castle nut to the pivot shaft. Remove the castle nut and flat washer.

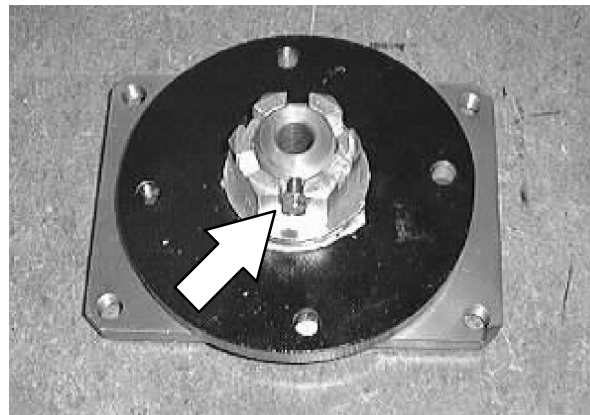

- Pull the cone bearing out of the swivel plate.

- Grease the new cone bearing. Reinstall the cone bearing into the swivel plate.

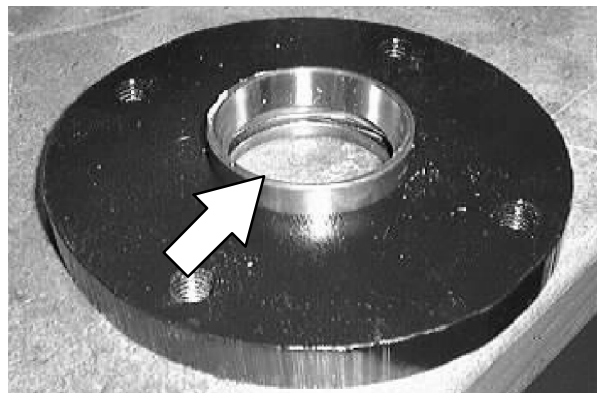

- Reinstall the large flat washer and castle nut. Tighten to 37 - 48 Nm (26 - 34 ft. lb). Reinstall the small thread roller into the cross hole. *Back off the castle nut if needed to align cross hole.*

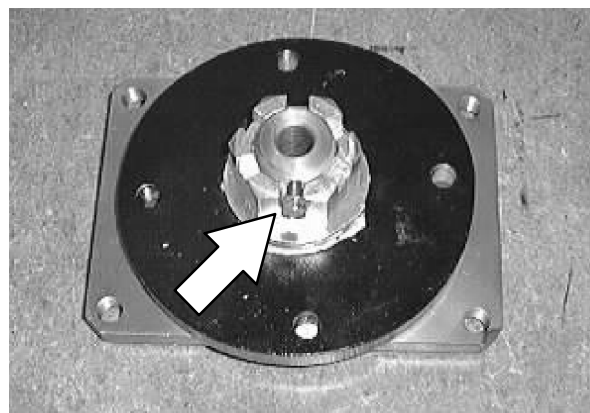

CHASSIS

13. Use a floor jack to reinstall the front drive assembly in the machine.

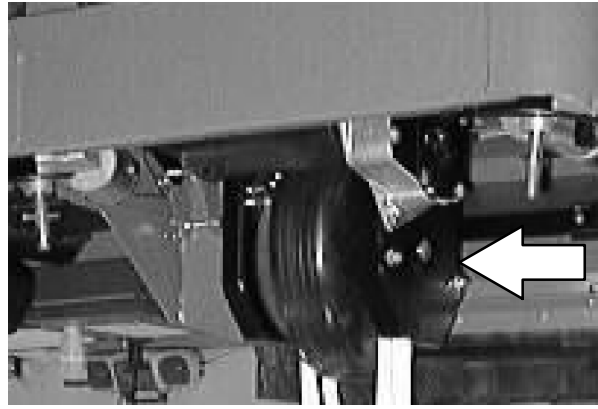

14. Line up the four threaded holes in the swivel plate weldment with the mount holes in the machine frame. Reinstall the four button head screws and tighten to 64 - 83 Nm (47 - 61 ft lb). *Make sure the drive motor is facing the front of the machine.*

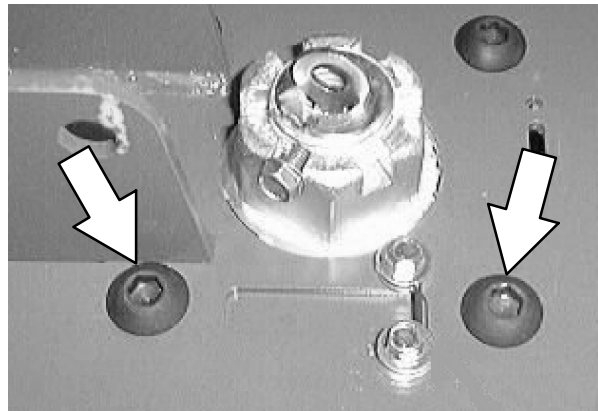

15. Reinstall the steering chain onto both steering sprockets. Reinstall the master link.

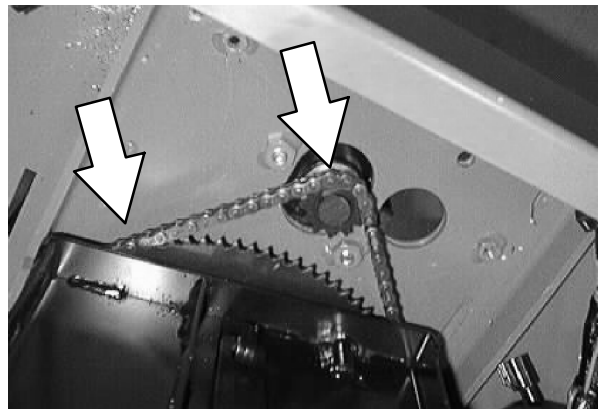

16. Go back to the operators compartment. Push the steering housing forward in the slots. This will remove any slack in the steering chain. Tighten the two hex screws to 37 - 48 Nm (26 - 34 ft lb).

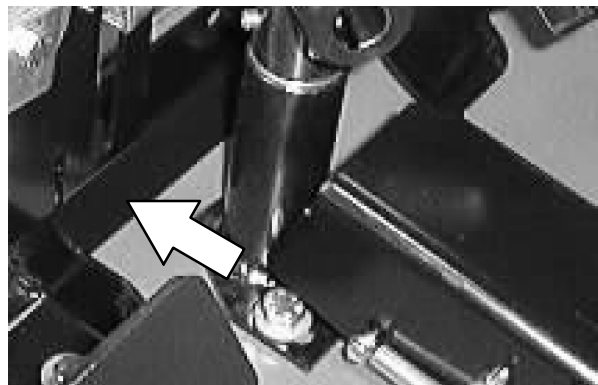

17. Reconnect the drive motor to the main harness.

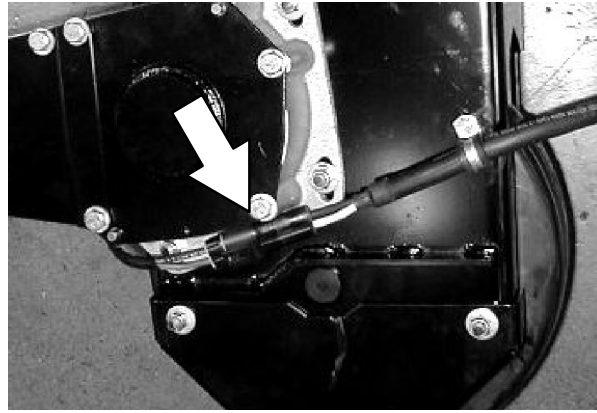

18. Reconnect the short brake rod to the brake pedal.

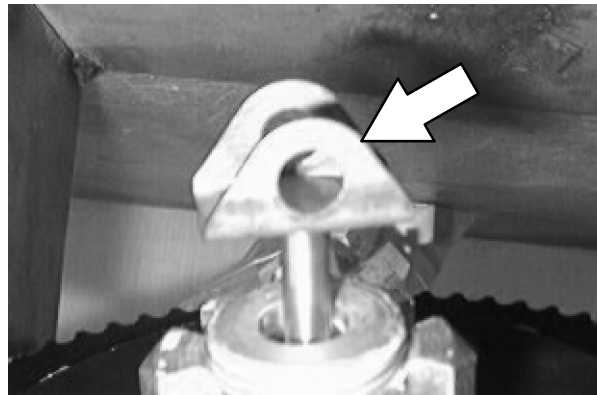

19. Reinstall the brake pedal and clevis pin.

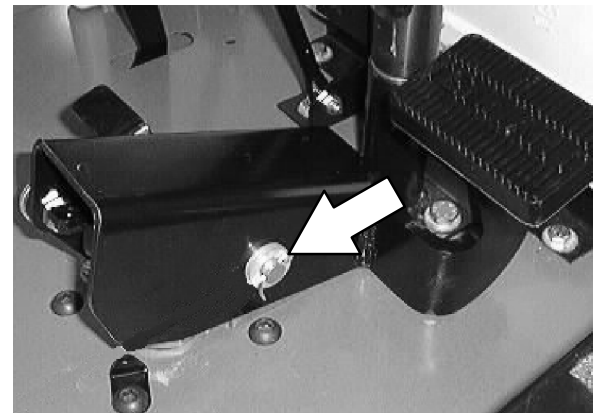

20. Remove the jack stands and lower the machine to the floor. Operate the machine and check the steering for proper operation.

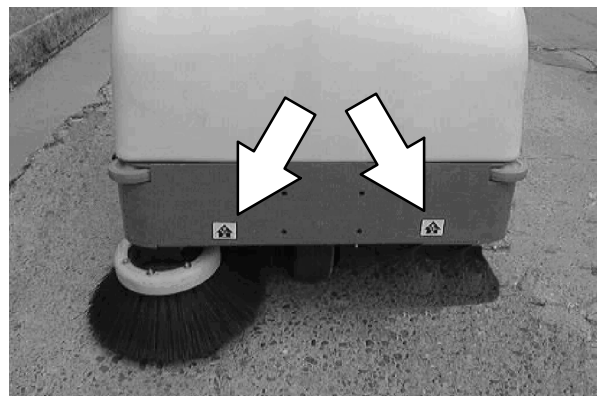

CONTENTS

	Page
INTRODUCTION	3-2
DEBRIS HOPPER	3-3
TO REMOVE HOPPER	3-4
TO INSTALL HOPPER	3-5
HOPPER DUST FILTER	3-6
TO REPLACE HOPPER DUST FILTER	3-7
MAIN BRUSH	3-10
TO REPLACE MAIN BRUSH	3-10
CHECKING AND ADJUSTING MAIN BRUSH PATTERN	3-13
MAIN BRUSH BELT	3-15
TO REPLACE MAIN BRUSH DRIVE BELT	3-15
TO REPLACE MAIN BRUSH IDLER PLUG BEARING	3-18
TO REPLACE MAIN BRUSH DRIVE PLUG BEARINGS	3-21
TO REPLACE MAIN BRUSH DRIVE BELT IDLER PULLEY	3-26
SIDE BRUSH	3-29
TO REPLACE SIDE BRUSH	3-30
SIDE BRUSH GUARD	3-32
SIDE BRUSH PIVOT	3-32
TO REPLACE SIDE BRUSH LIFT CABLE	3-33
SKIRTS AND SEALS	3-35
REAR SKIRT	3-35
SIDE SKIRTS	3-36
TO ADJUST SIDE SKIRTS	3-36
LARGE DEBRIS TRAP SKIRT	3-38
TO ADJUST FRONT FLAP SKIRT ..	3-38
HOPPER SEALS	3-39
TO ADJUST RECIRCULATING SKIRT CAM.	3-40
VACUUM FAN	3-42
VACUUM FAN BELT	3-42
TO REPLACE VACUUM FAN DRIVE BELT	3-43
TO TENSION VACUUM FAN DRIVE BELT	3-46
TO REPLACE VACUUM FAN IMPELLER	3-48
TO REPLACE VACUUM FAN IMPELLER BEARINGS	3-53
MACHINE TROUBLESHOOTING	3-60

INTRODUCTION

This section includes information on the sweeping operation of the model 6100E. The side brush sweeps debris in front of the machine and the main brush sweeps the debris into the hopper. The vacuum fan pulls air from the hopper and through the dust filter.

DEBRIS HOPPER

The hopper is located in the rear of the machine under the battery compartment. The hopper rolls in and out of position and rests in grooves that hold the hopper in place.

The hopper is held in operating position with a retaining clip.



NOTE: Check that the hopper retaining clip is securely in place each time before operating machine.



SWEEPING

TO REMOVE HOPPER

FOR SAFETY: Before Leaving Or Servicing Machine; Stop On Level Surface, Set Parking Brake.

1. Go to the back of the machine.
2. Grasp the hopper retainer clip. Turn the retainer clip out of the way of the hopper lip.



3. Grasp the hopper handle. Pull up slightly then pull out on the hopper.



4. Remove the hopper from the machine.



TO INSTALL HOPPER

FOR SAFETY: Before Leaving Or Servicing Machine; Stop On Level Surface, Set Parking Brake.

1. Position the hopper into the back of the machine.



2. Push the hopper in until it is flush with the back of the machine frame.



3. Rotate the retainer clip down to lock the hopper in the machine.



HOPPER DUST FILTER

The Instant Access™ hopper filter filters the air pulled up from the hopper. The dust filter is equipped with a shaker to remove the accumulated dust particles. The dust filter shaker is operated by the main brush, vacuum and filter shaker switch.

Shake the dust filter before emptying the hopper and at the end of every work shift. Check and clean or replace the dust filter after every 100 hours of operation.

To clean the Instant Access™ filter, use one of the following methods:

- **SHAKING** - Press and hold the main brush, vacuum and filter shaker switch to the **Filter shaker** position.
- **TAPPING** - Remove the filter and tap the filter gently on a flat surface with the dirty side down. Do not damage the edges of the filter element and seals, or the filter will not seat properly in the filter frame.
- **AIR** - Blow air through the dust filter, opposite the direction of the arrows. This may be done with the dust filter in the machine. Always wear eye protection when using compressed air.

FOR SAFETY: When servicing machine, wear eye and ear protection if using pressurized air or water.

- **WATER** - Soak the dust filter in a water and mild detergent solution. Rinse the dust filter until it is clean. Air dry the wet dust filter; do not use compressed air to dry a wet filter.

NOTE: Be sure the dust filter is completely dry before reinstalling it in the machine.

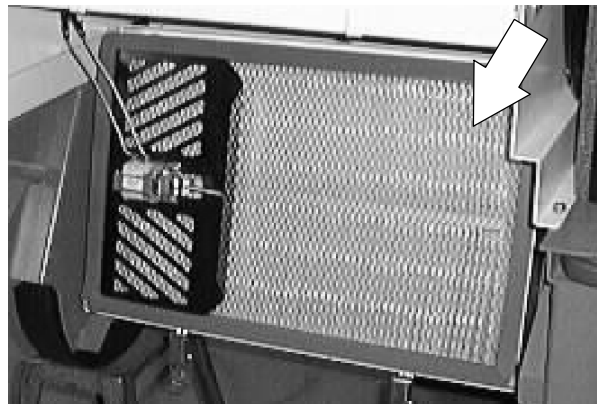
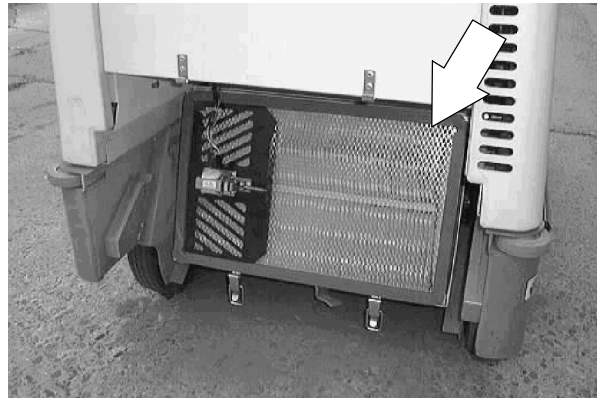

TO REPLACE HOPPER DUST FILTER

FOR SAFETY: Before Leaving Or Servicing Machine; Stop On Level Surface, Set Parking Brake.

1. Remove the debris hopper from the machine.

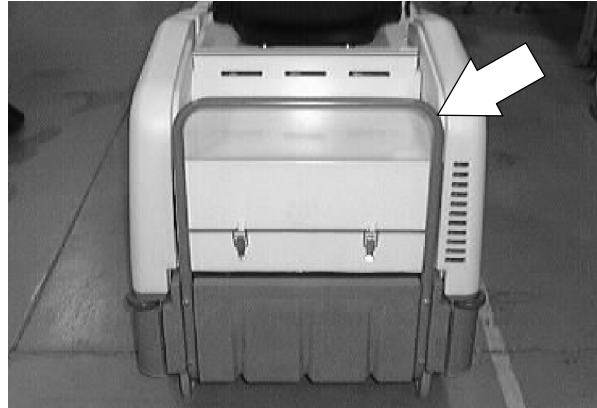

2. Un-latch the two filter pivot latches at the rear of the machine.

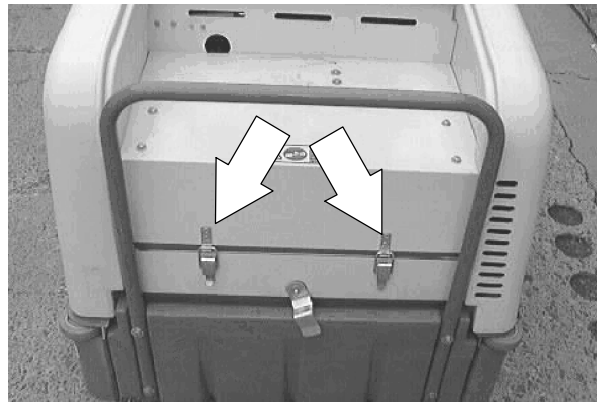

3. Let the hooper filter pivot down.

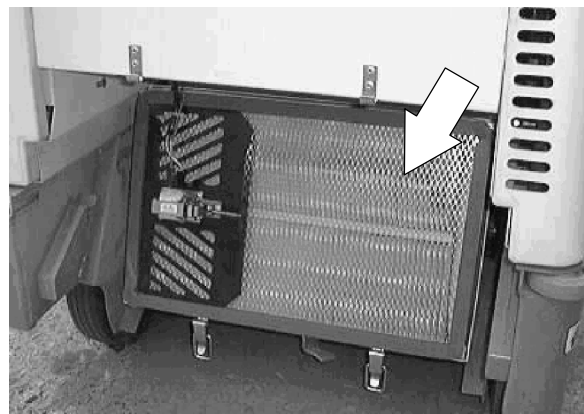

SWEEPING

4. Disconnect the wires leading to the filter shaker.

NOTE: Apply pressure between the shaker solenoid terminals when removing the wires.

5. Remove the filter from the filter tray.

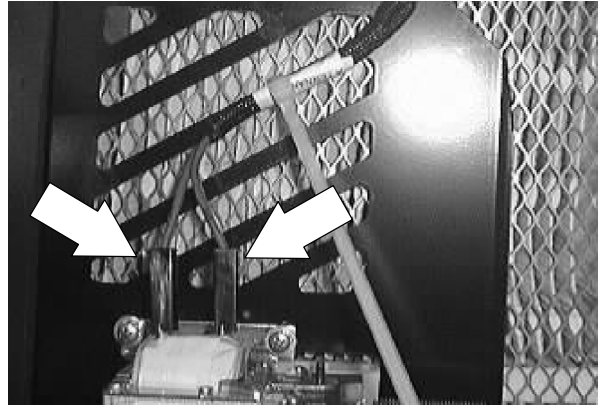

6. Pull back on the tension spring located on the shaker assembly. Cut the plastic ties holding the shaker to the filter.

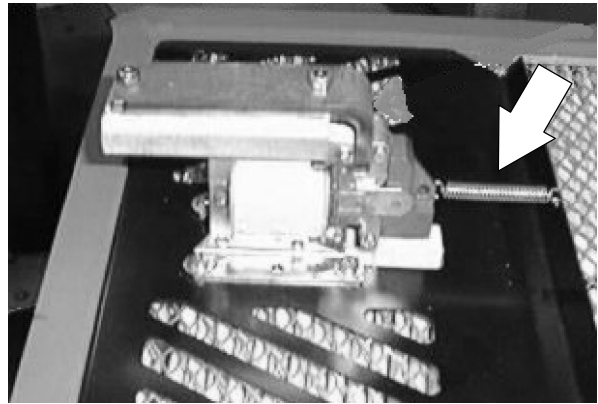

7. Remove the filter shaker assembly from the filter.

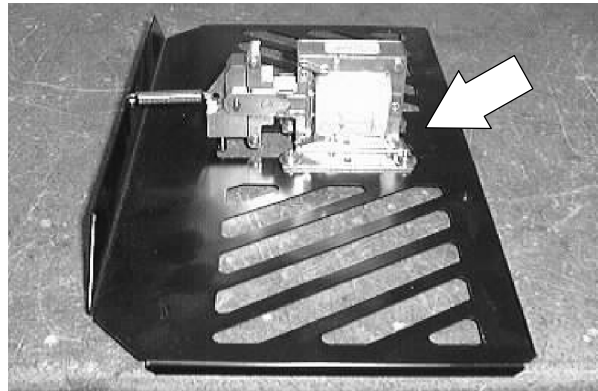

8. Install the filter shaker assembly onto the new filter. Make sure the pin on the shaker assembly is inserted in the hole in the filter shaker comb.

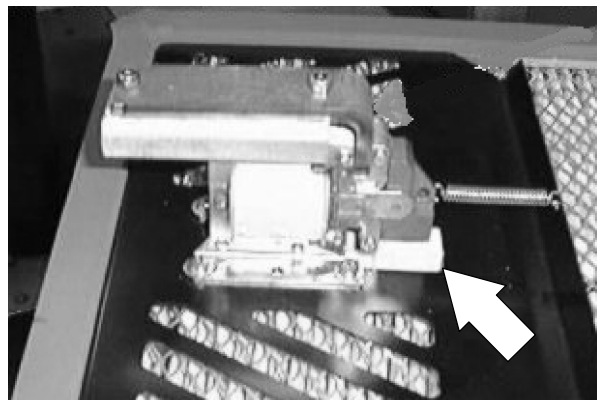

9. Make sure the filter shaker assembly is installed properly, the edge of the shaker should be between the filter and the filter seal.

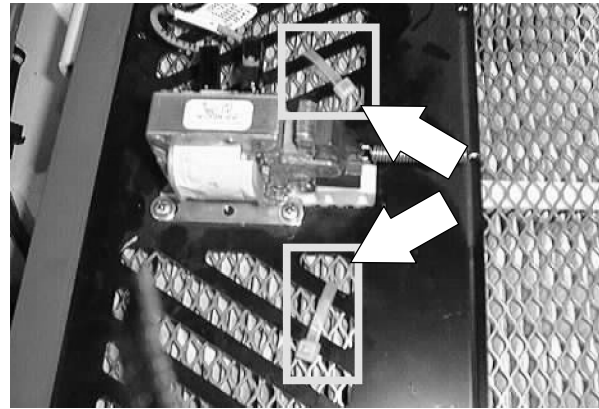

10. Reinstall the filter assembly into the filter tray.

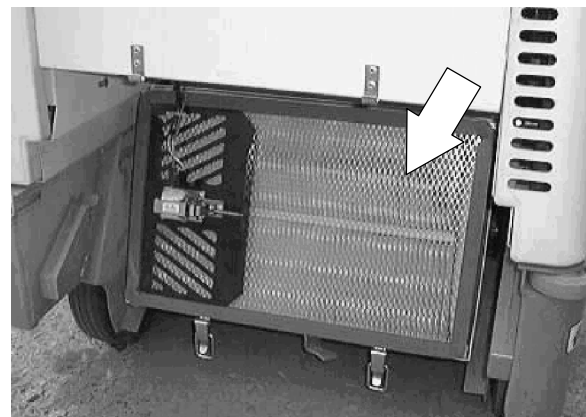

11. Reconnect the wires to the filter shaker.



12. Pivot the filter tray up and re-latch the latches.

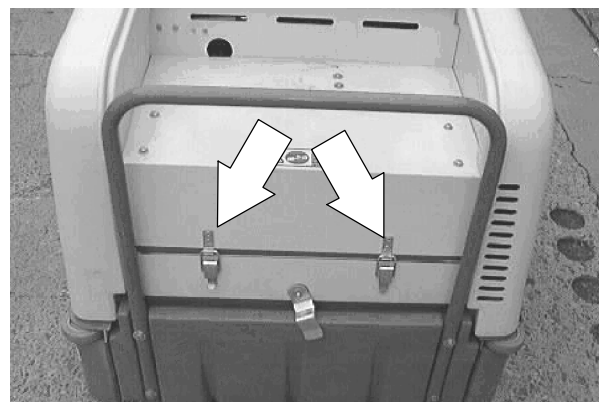

13. Reinstall the debris hopper and lock the retainer bracket.

SWEEPING

MAIN BRUSH

The main brush is cylindrical and spans the width of the machine, sweeping debris into the hopper.

Check the brush daily for wear or damage. Remove any string or wire tangled on the main brush, main brush drive hub, or main brush idler hub.

Check the main brush pattern weekly. The pattern should be 50 to 75 mm (2 to 3 in) wide with the main brush in the lowered position.

Rotate the main brush end-for-end after every 50 hours of operation for maximum brush life and best sweeping performance.

Replace the main brush when the remaining bristles measure 25 mm (1 in) in length.

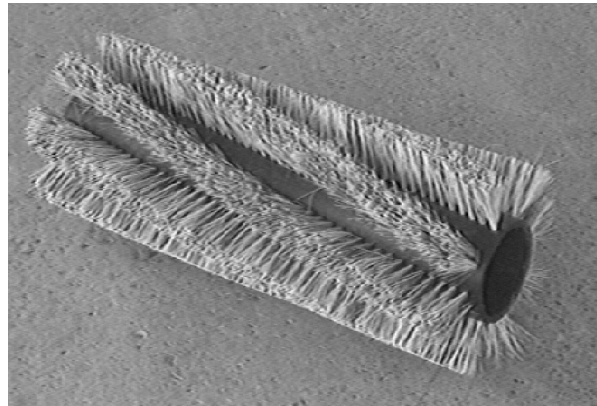

TO REPLACE MAIN BRUSH

FOR SAFETY: Before Leaving Or Servicing Machine; Stop On Level Surface, Set Parking Brake.

1. Stop the machine, set the parking brake and turn the machine power off.

FOR SAFETY: Before leaving or servicing machine, stop on level surface, set parking brake, turn off machine, and remove key.



2. Open the left side main brush access door.

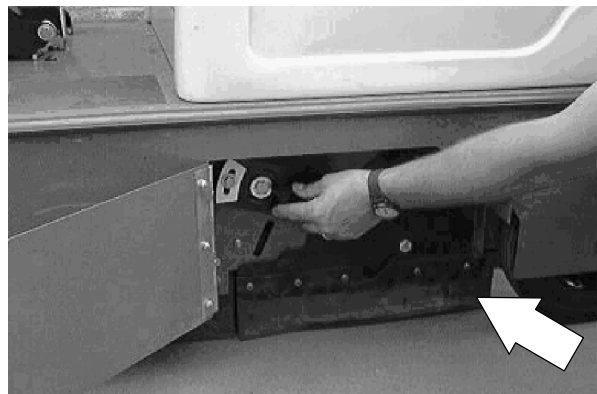

3. Loosen the idler arm mounting knob and three other side skirt mounting knobs. Remove the brush idler arm assembly.

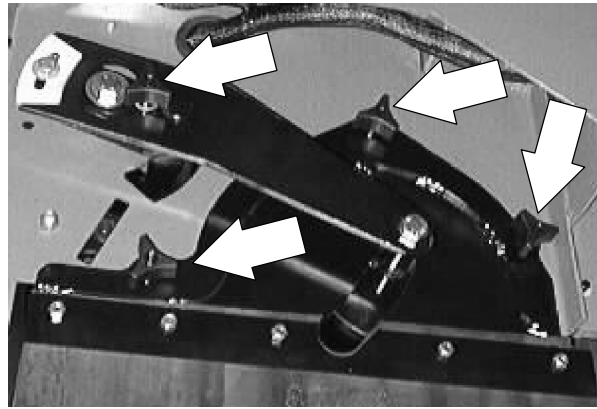

4. Grasp the main brush; pull it off the brush drive plug and out of the main brush compartment.

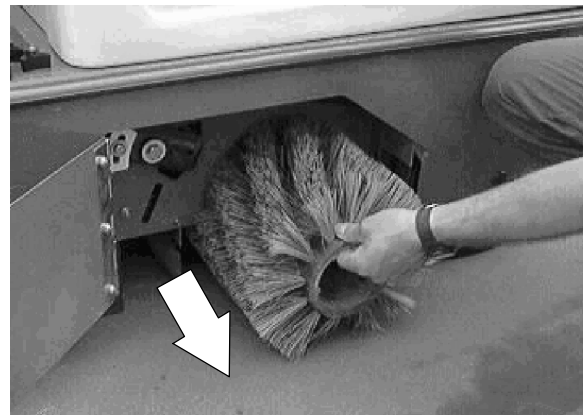

5. Put the new or rotated end-for-end main brush on the floor next to the access door.

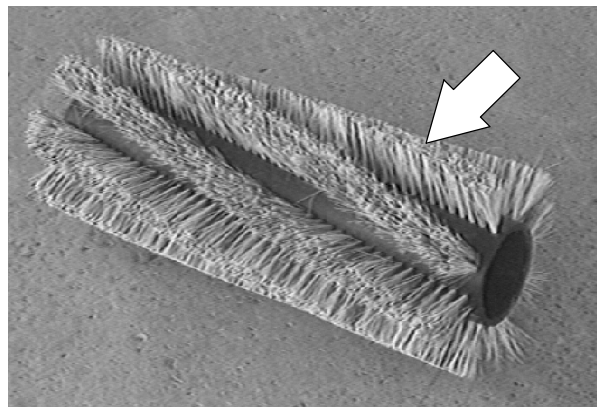

6. Slide the main brush onto the drive plug. Rotate the brush until it engages the drive plug, and push it all the way onto the plug.

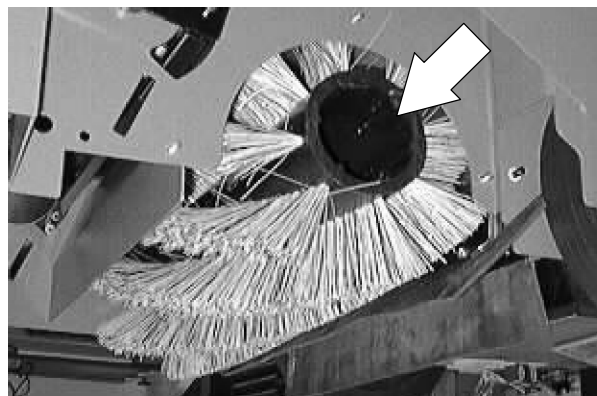

SWEEPING

7. Check that the recirculation skirt is tucked in behind the frame.

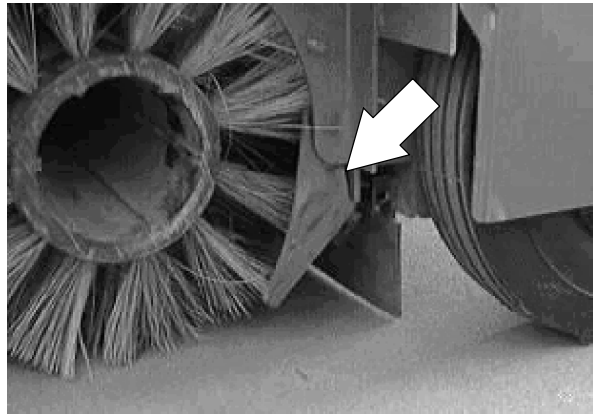

8. Slide the main brush idler arm plug onto the main brush.

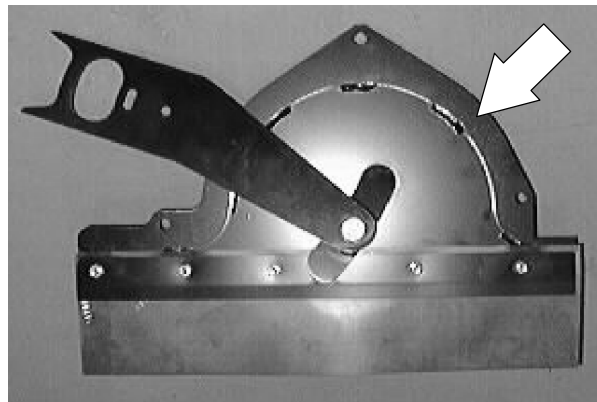

9. Secure the idler arm on the bolts. Hand tighten the mounting knobs.

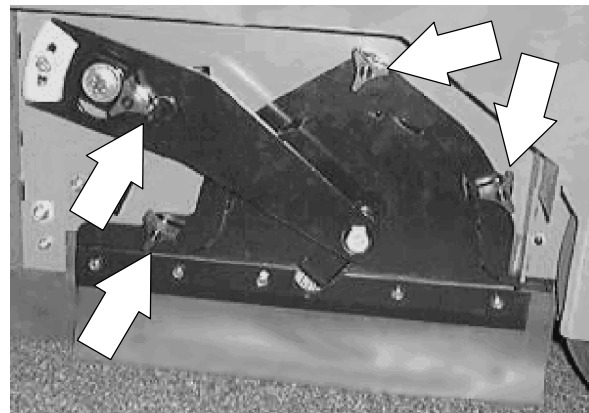

10. Close the main brush access door.

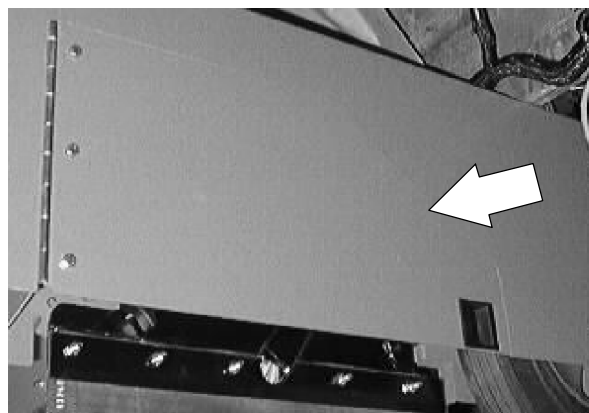

CHECKING AND ADJUSTING MAIN BRUSH PATTERN

1. Apply chalk, or some other material that will not blow away easily, to a smooth, level floor.
2. Raise the side brush and main brush and position the main brush over the chalked area.

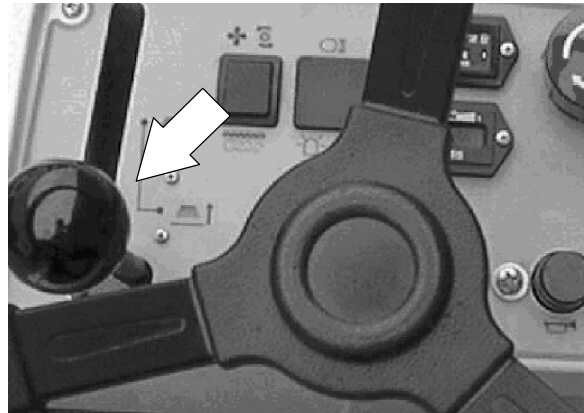

3. Start and lower the main brush for 15 to 20 seconds while keeping a foot on the brakes to keep the machine from moving.

NOTE: If chalk or other material is not available, allow the brushes to spin on the floor for two minutes. A polish mark will remain on the floor.

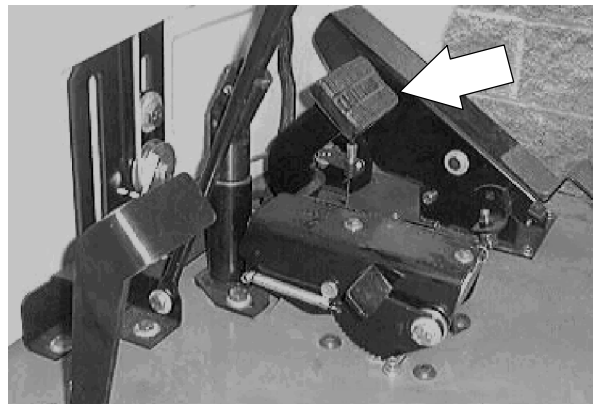

4. Raise the main brush.
5. Drive the machine off the test area.



SWEEPING

6. Observe the width of the brush pattern. The proper brush pattern width is 50 to 75 mm (2 to 3 in).

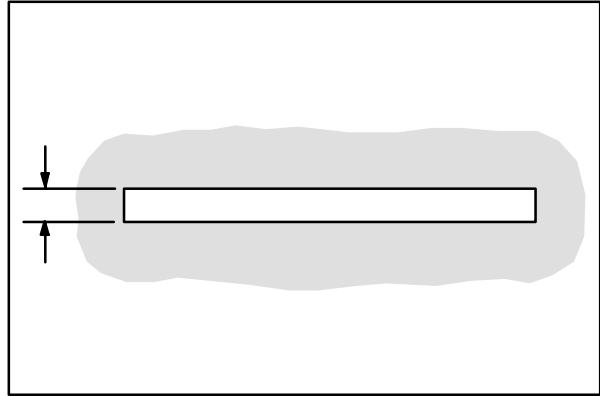

The brush taper is factory set and should not need adjustment unless parts of the brush system have been replaced.

If the main brush pattern is tapered, more than 15 mm (0.5 in) on one end than the other, adjust the taper as follows:

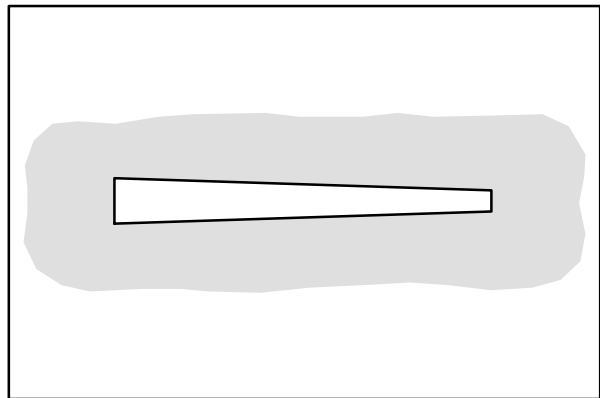

1. Loosen the brush shaft bearing bracket mounting bolt and the idler arm securing head.
2. Allow the brush to operate and float into position for approximately 30 seconds.
3. Tighten the adjustment bolt and idler arm securing knob.
4. Check the main brush pattern and readjust as necessary.



MAIN BRUSH BELT

Check the main brush belt for wear after every 200 hours of operation. The idler keeps tension on the belt. The tension is set manually.



WARNING: Moving belt and fan. Keep away.

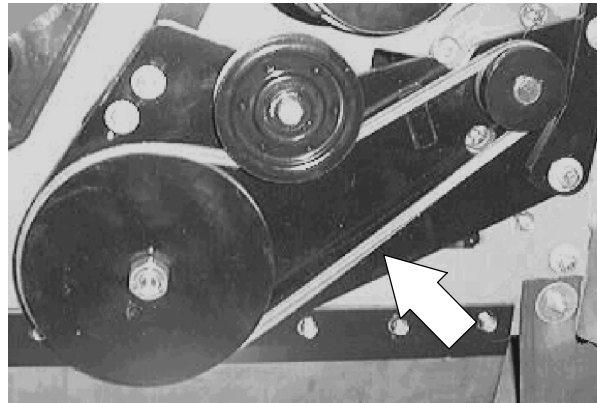

TO REPLACE MAIN BRUSH DRIVE BELT

FOR SAFETY: Before Leaving Or Servicing Machine; Stop On Level Surface, Set Parking Brake.

1. Remove the four screws holding the right hand brush door to the machine frame. Remove the right hand side brush door.

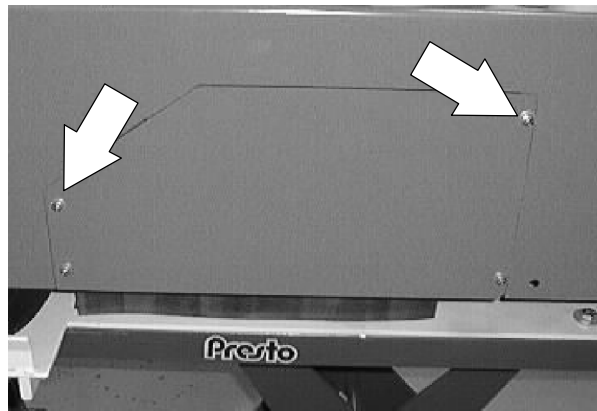

2. Locate the main brush drive belt idler pulley between the small motor drive pulley and the larger brush pulley.

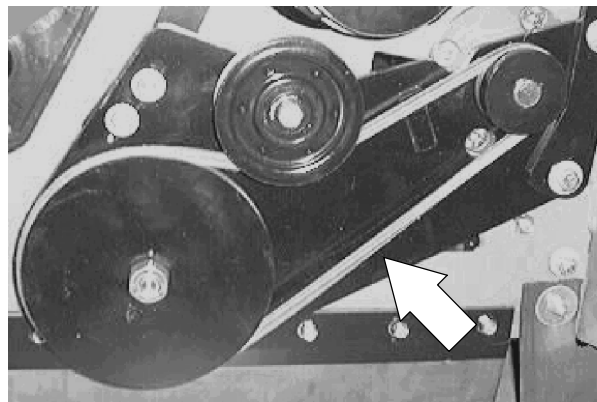

SWEEPING

3. Loosen the hex nut in the center of the idler pulley.

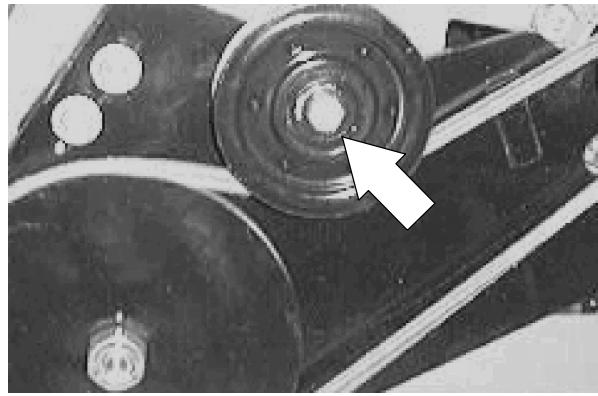

4. Push the idler pulley back in the slot.

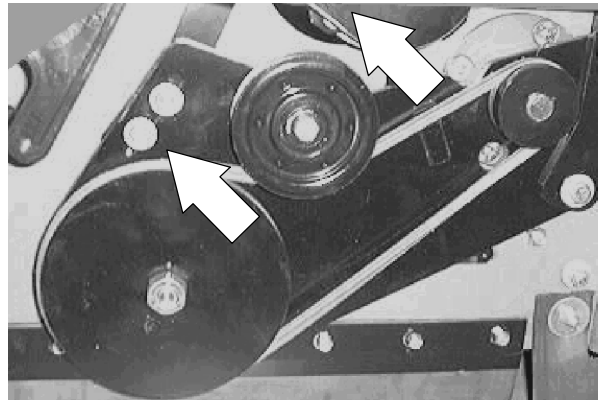

5. Remove the main brush drive belt from the two remaining pulleys. Remove and discard the old drive belt.

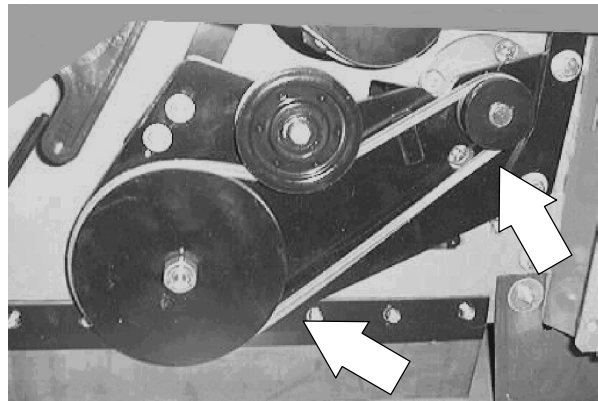

6. Position the new main brush drive belt onto the motor and brush drive pulleys.

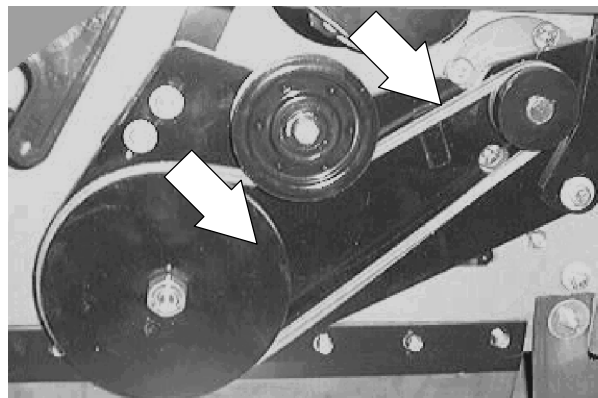

7. Move the idler pulley forward in the slot until the belt is tight. Tighten the hex nut to 18 - 24 Nm (15 - 20 ft lb).

8. Reinstall the right hand side brush door.

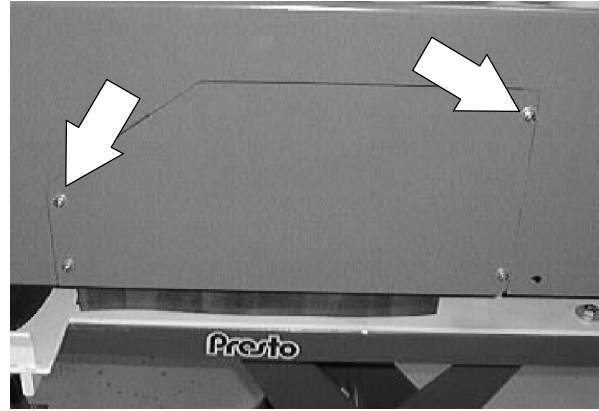

9. Operate the machine and check the main brush for proper operation.

SWEEPING

TO REPLACE MAIN BRUSH IDLER PLUG BEARING

FOR SAFETY: Before Leaving Or Servicing Machine; Stop On Level Surface, Set Parking Brake.

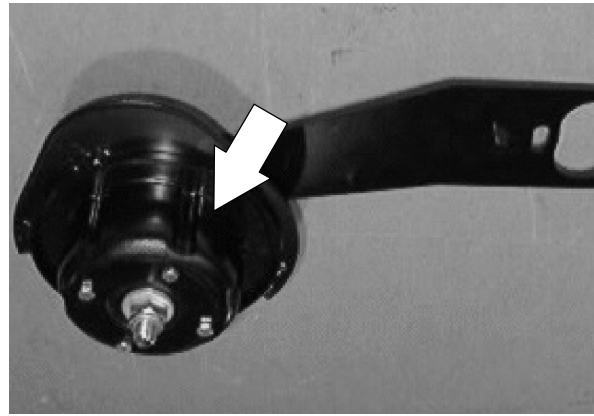

1. Open the left hand side brush door.

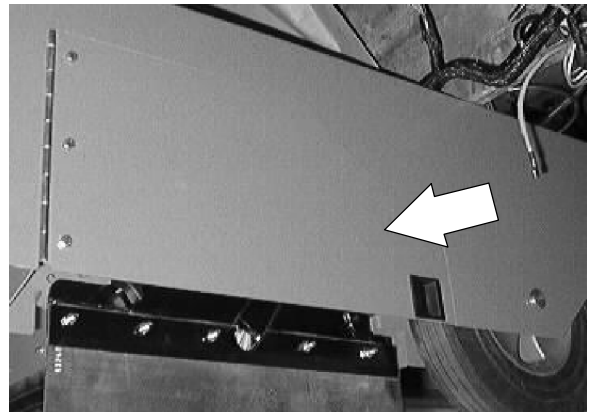

2. Remove the main brush idler mount plate. See TO REPLACE MAIN BRUSH instructions in this sections.

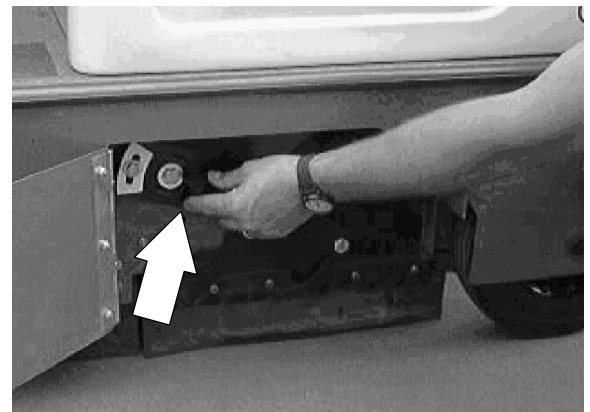

3. Remove the hex screw, nut, and washer holding the idler plug assembly to the brush lift plate.

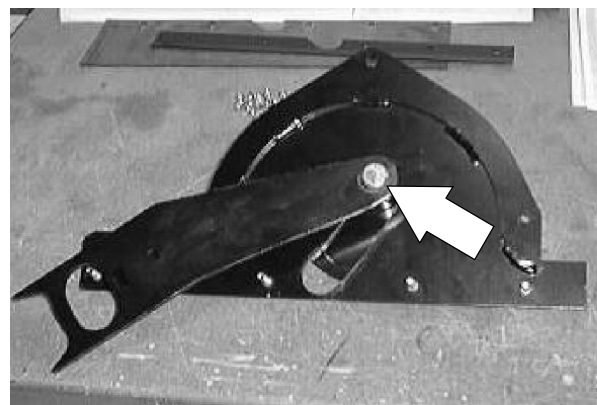

4. Remove the idler plug assembly from the lift plate.

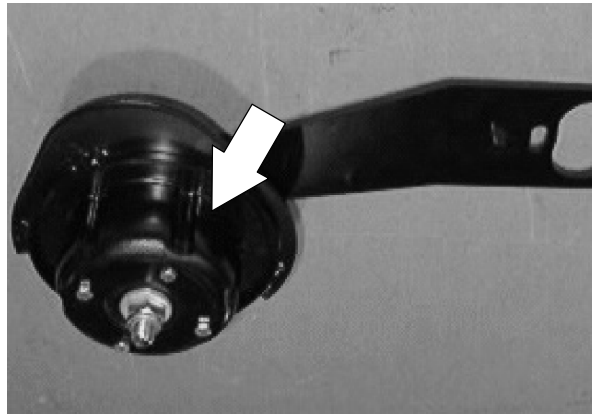

5. Remove the four hex screws holding the bearing retainer to the idler plug. Remove the retainer.



6. Remove and discard the idler ball bearing from the idler plug.



7. Position the new ball bearing into the idler plug.

8. Reinstall the bearing retainer plate on the idler plug. Reinstall the four screws and tighten to 8 - 10 Nm (6 - 7 ft lb).

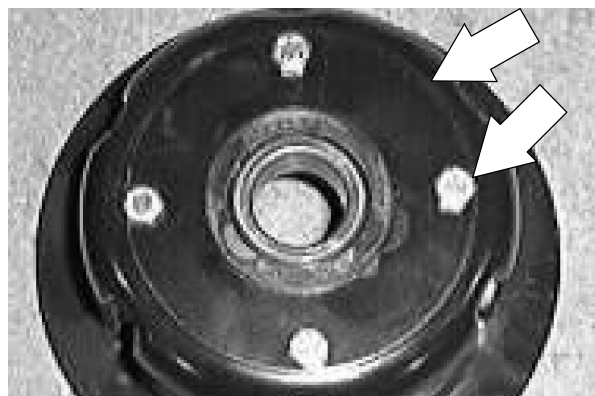

SWEEPING

9. Reinstall the idler plug assembly onto the brush lift plate. Reinstall the hex screw, washer, and nyloc nut. Tighten to 37 - 48 Nm (26 - 34 ft lb).

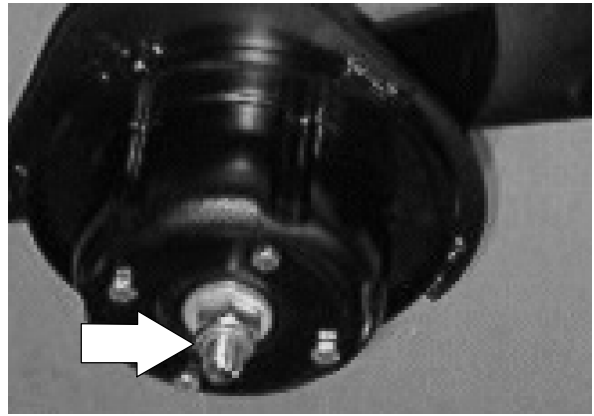

10. Reinstall the main brush idler mount plate. See TO REPLACE MAIN BRUSH instructions in this sections.

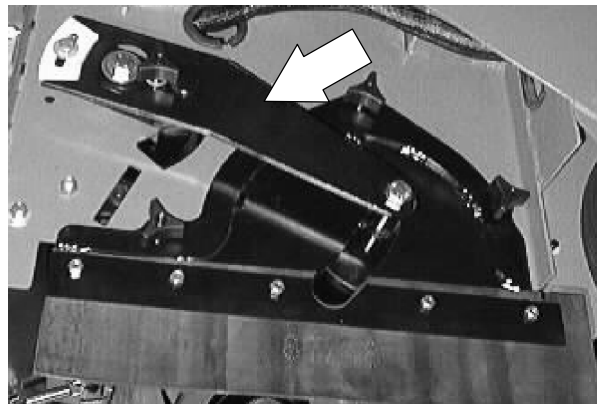

11. Close the left hand side brush door.

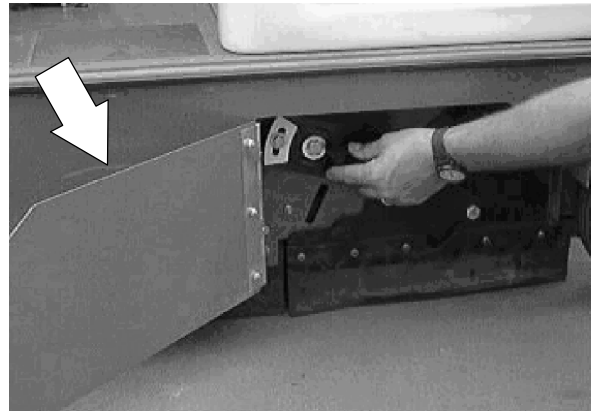

12. Operate the machine and check the main brush for proper operation.



TO REPLACE MAIN BRUSH DRIVE PLUG BEARINGS

FOR SAFETY: Before Leaving Or Servicing Machine; Stop On Level Surface, Set Parking Brake.

1. Jack up the front of the machine at the jack points. Install jack stands under the machine frame.

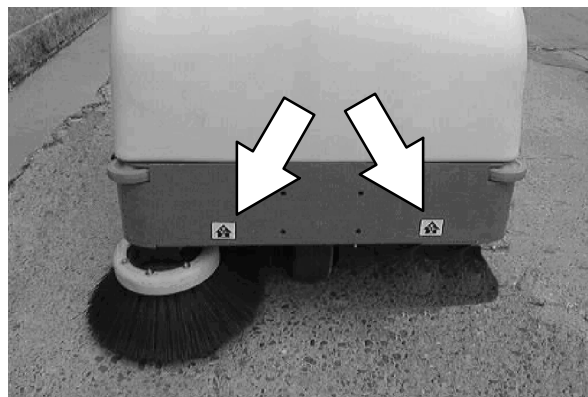

2. Open the left hand side brush door.
3. Remove the main brush idler mount plate and main brush. See TO REPLACE MAIN BRUSH instructions in this sections.



4. Remove the right hand brush door.

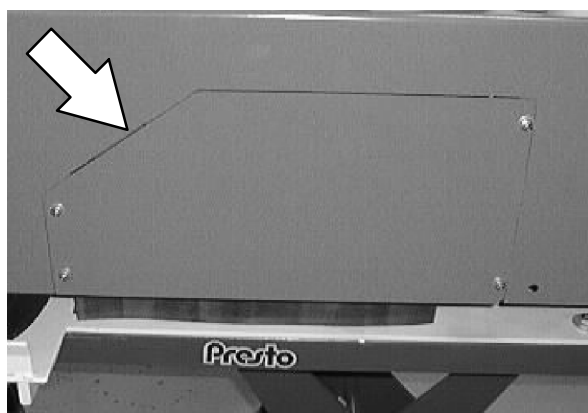

SWEEPING

5. Remove the main brush drive belt. See TO REPLACE MAIN BRUSH DRIVE BELT instructions in this section.

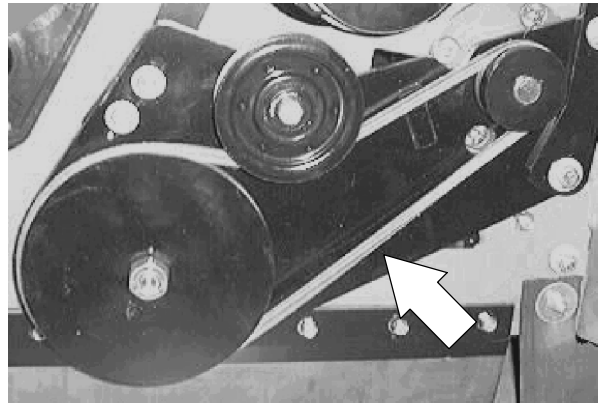

6. Hold the main brush V-belt pulley (large one) from turning. Remove the large nut from the center of this pulley. **NOTE: THIS IS A LEFT HAND THREAD NUT.**

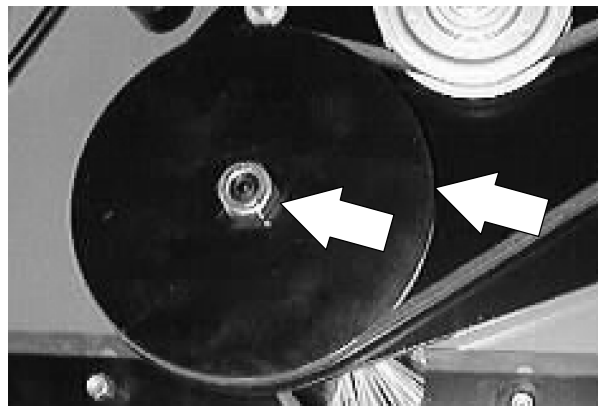

7. Remove the main brush V-belt pulley (larger one) from the main brush shaft. Make sure to retain the washer from behind the pulley.

8. Hold the main brush drive plug from turning. Remove the large nut from the center of the drive plug. **NOTE: THIS IS A LEFT HAND THREAD NUT.**

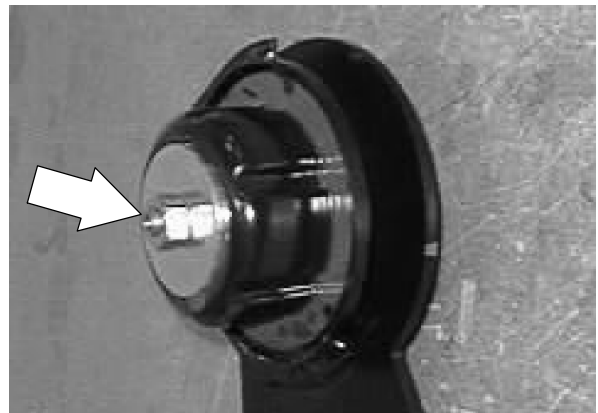

9. Remove the main brush idler plug assembly from the main brush shaft.



10. Reinstall the nut on the outside of the main brush shaft.
11. Use a hammer to lightly tap on the end of the shaft with the nut reinstalled. Tap on the shaft until the inner bearing is out of the housing.
12. Remove the nut from the main brush shaft. Remove the shaft and bearing from the machine.
13. Use a long screw driver or punch to remove the remaining outer bearing from the main brush housing. Discard the bearing.
14. Use an arbor press to remove the bearing from the main brush shaft. Discard the bearing.
15. Install one new bearing onto the main brush shaft.
16. Install one new bearing into the outer side of the main brush housing.

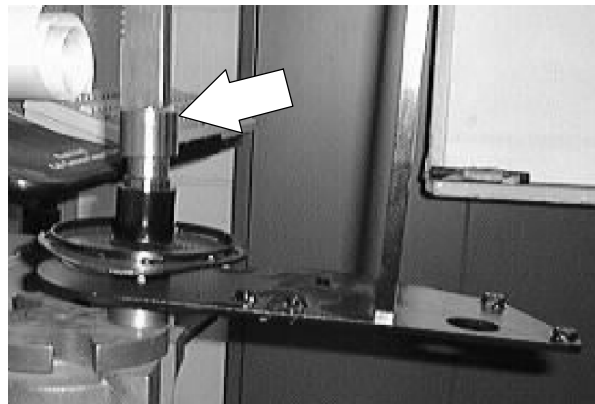
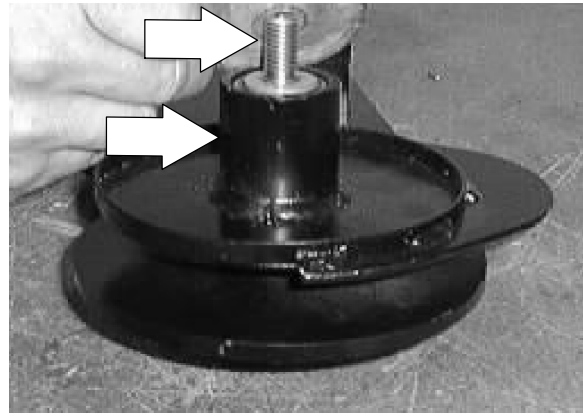

17. Install the new bearing and main brush shaft assembly into the main brush housing. Install one of the nuts onto the outside of the main brush shaft. Use a hammer to lightly tap the bearing and shaft into the housing.

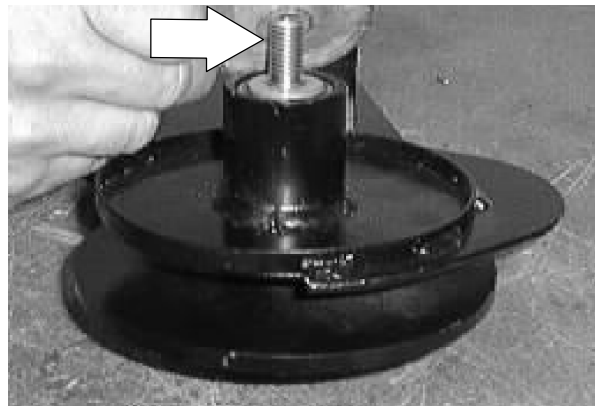

18. Reinstall the main brush drive plug onto the main brush shaft on the inside. Reinstall the left hand nut. Hand tighten tight. *Make sure the large washer is in place behind the brush plug.*

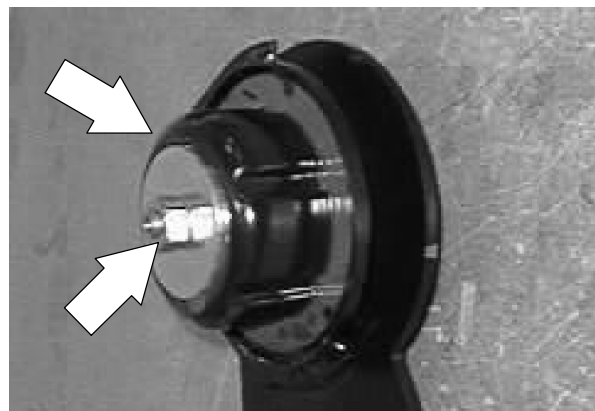

SWEEPING

19. Reinstall the washer and V-belt pulley onto the outside of the main brush shaft. Reinstall the left hand nut. Tighten to 52 - 67 Nm (39 - 51 ft lb).

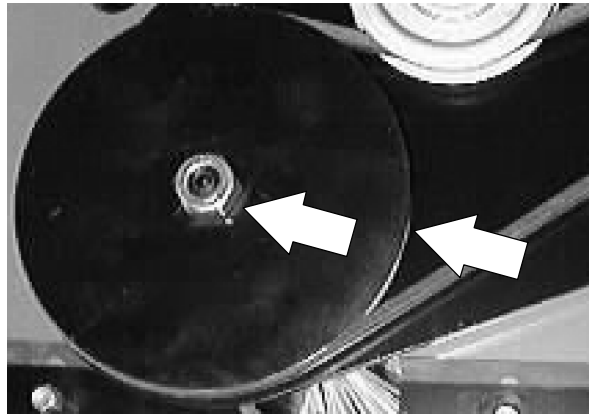

20. Reinstall the main brush drive belt. See TO REPLACE MAIN BRUSH DRIVE BELT instructions in this section.

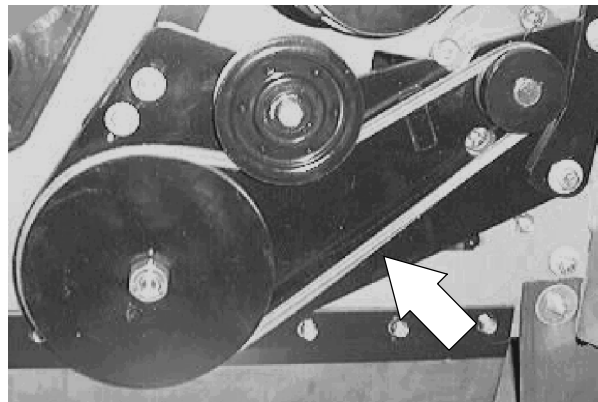

21. Reinstall the main brush. See TO REPLACE MAIN BRUSH instructions in this sections.

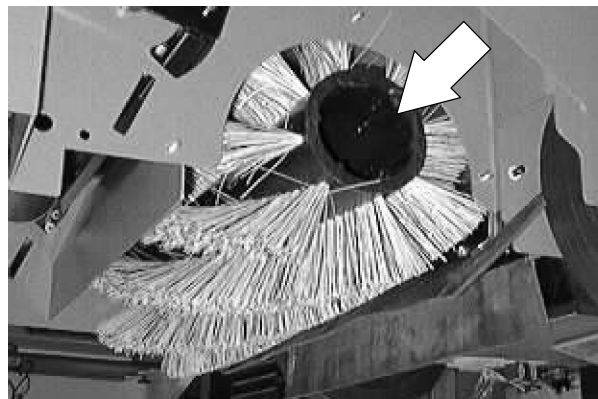

22. Reinstall the right hand brush door and close the left hand brush door.

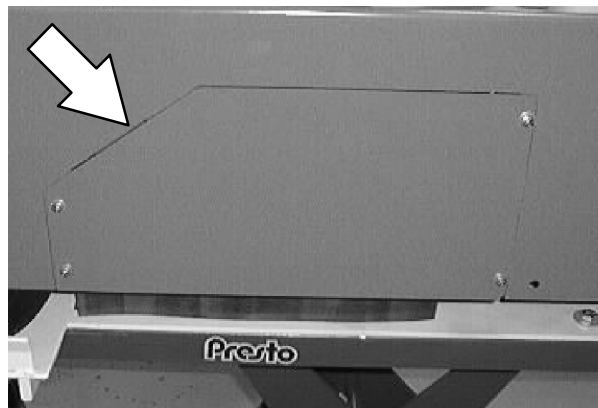

23. Remove the jack stands and lower the machine.

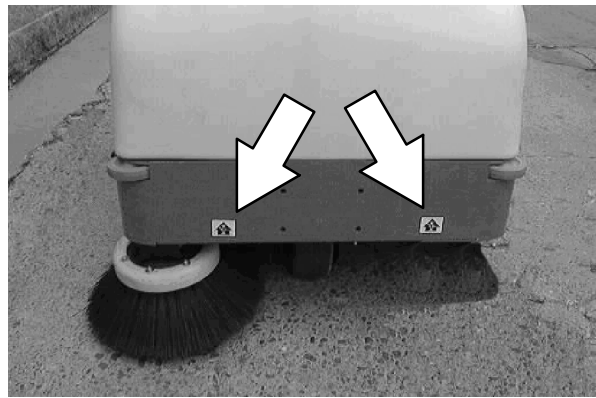

24. Operate the machine and check the main brush for proper operation.



SWEEPING

TO REPLACE MAIN BRUSH DRIVE BELT IDLER PULLEY

FOR SAFETY: Before Leaving Or Servicing Machine; Stop On Level Surface, Set Parking Brake.

1. Remove the four screws holding the right hand brush door to the machine frame. Remove the right hand side brush door.

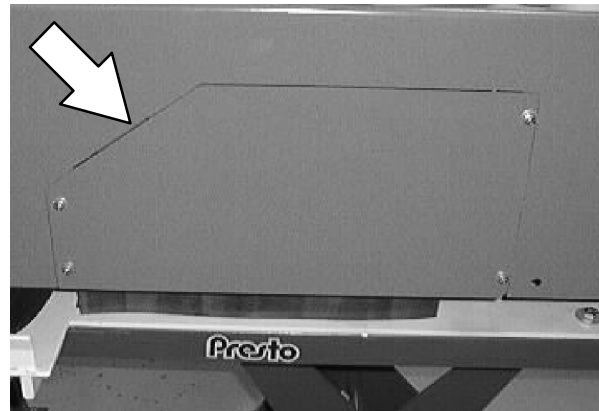

2. Locate the main brush drive belt idler pulley between the small jackshaft pulley and the larger brush pulley.

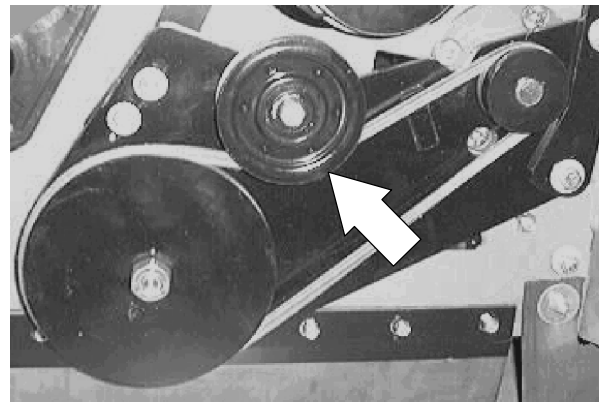

3. Loosen the hex nut in the center of the idler pulley.

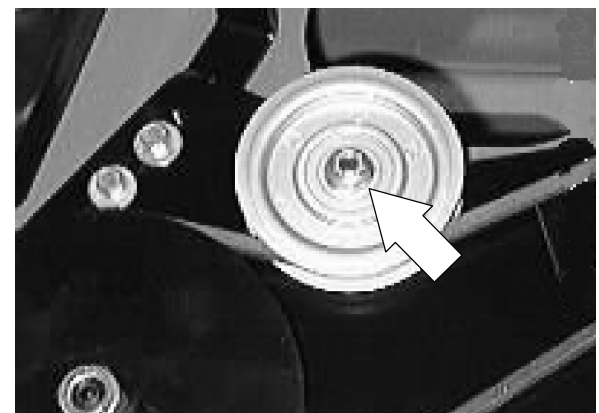

4. Push the idler pulley back in the slot.

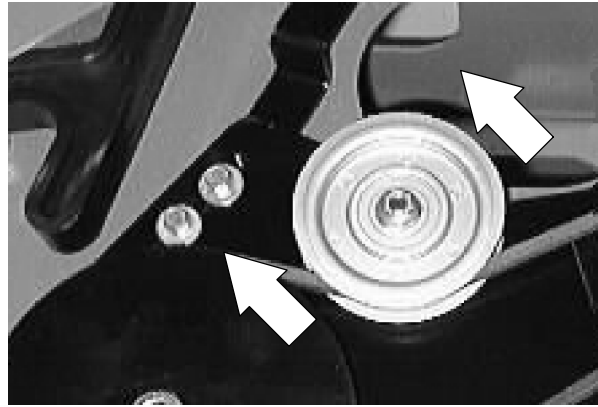

5. Remove the main brush drive belt from the two remaining pulleys.

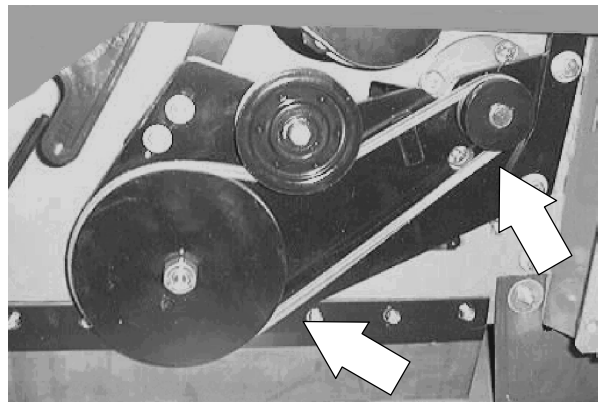

6. Remove the hex nut in the center of the idler pulley. Remove and discard the pulley.

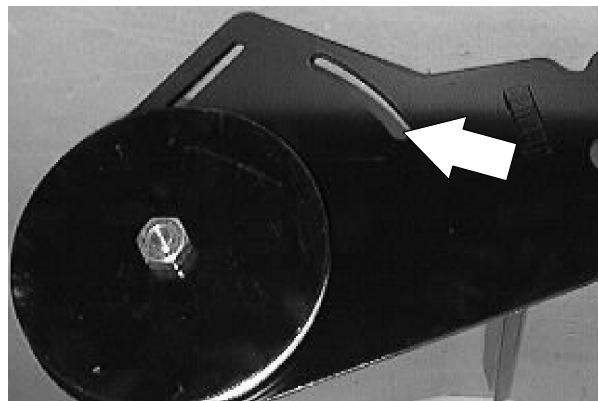

7. Install the new idler pulley onto the hex bolt. Reinstall the hex nut. Leave loose for now.

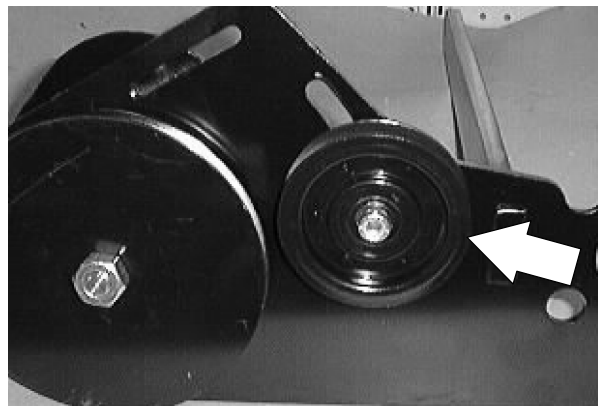

SWEEPING

8. Reinstall the V-belt around the two drive pulleys and on top of the idler pulley.

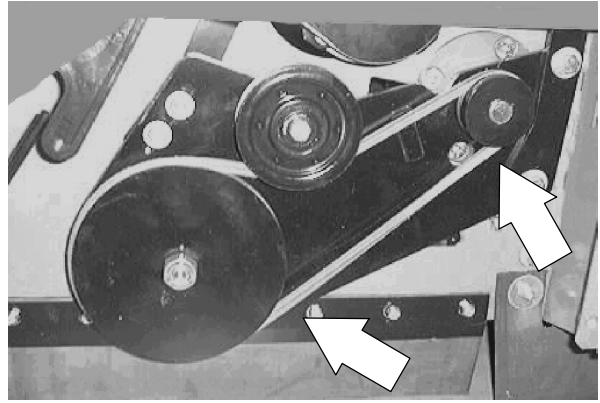

9. Push down on the idler pulley until the belt is tight. Tighten the pulley nut to 18 - 24 Nm (15 - 20 ft lb).

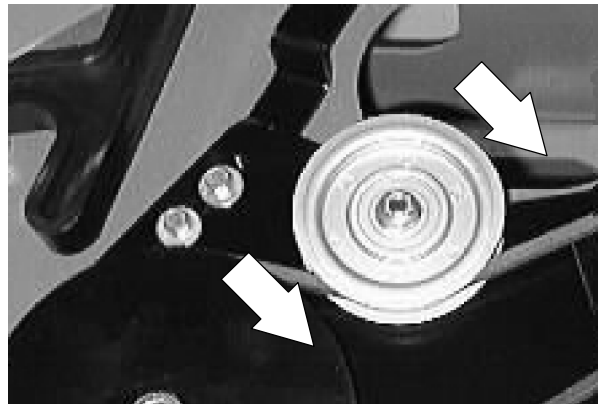

10. Reinstall the right hand side brush door.

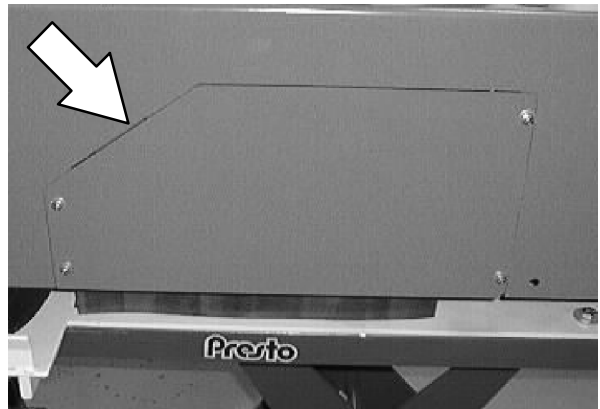

11. Operate the machine and check the main brush for proper operation.



SIDE BRUSH

The side brush sweeps debris along edges into the path of the main brush.

Check the brush daily for wear or damage. Remove any string or wire found tangled on the side brush or side brush drive hub.

Check the side brush pattern daily. The side brush bristles should contact the floor in a 10 o'clock to 3 o'clock pattern when the brush is in motion. Adjust the side brush pattern by loosening the hex screw located above the side brush cable pulley in the front of the operators compartment. Move the pulley mount bracket up or down to achieve the proper side brush pattern. Retighten the hex screw.

The side brush should be replaced when it no longer sweeps effectively for your application. A guideline length is when the remaining bristles measure 50 mm (2 in) in length. You may need to replace the side brush sooner if you are sweeping light litter or use a brush with shorter bristles if you are sweeping heavy debris.

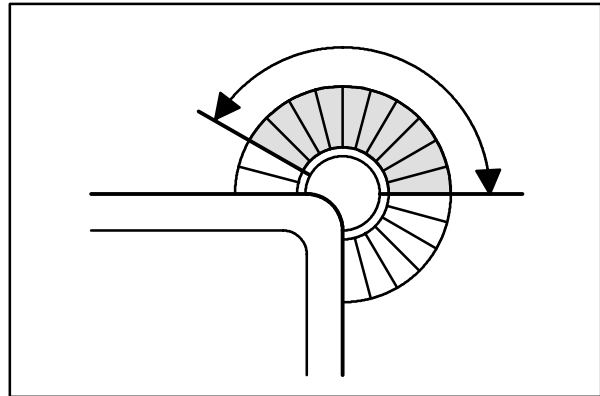

SWEEPING

TO REPLACE SIDE BRUSH

1. Stop the machine, set the parking brake and turn the machine power off.

FOR SAFETY: Before Leaving Or Servicing Machine; Stop On Level Surface, Set Parking Brake.

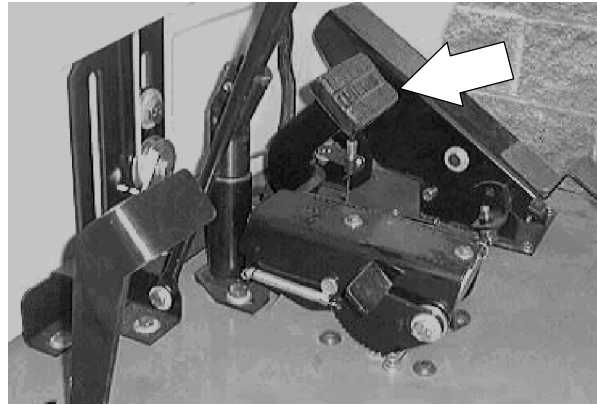

2. Remove the side brush retaining pin from the side brush drive shaft by pulling the pin keeper off over the end of the pin.



3. Slide the side brush off the side brush drive shaft.

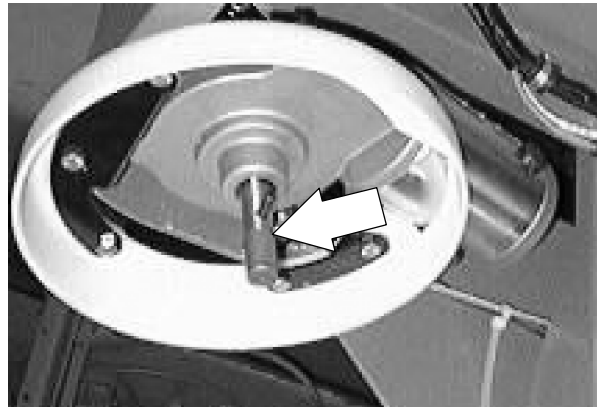

4. Slide the new side brush onto the side brush drive shaft.

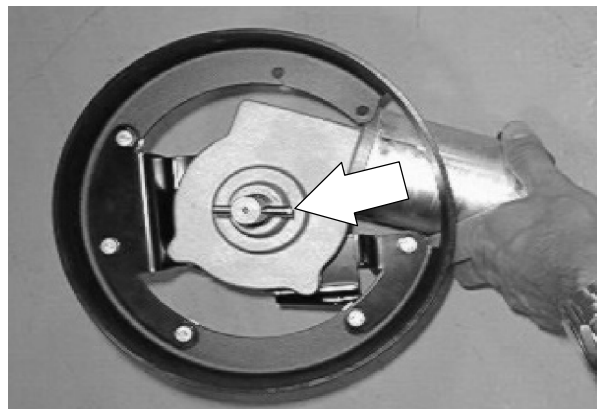

5. Insert the side brush retaining pin through the side brush hub and shaft.
6. Secure the pin by clipping the pin keeper over the end of the pin.



7. Adjust the side brush pattern by loosening the hex screw located above the side brush cable pulley in the front of the operators compartment.

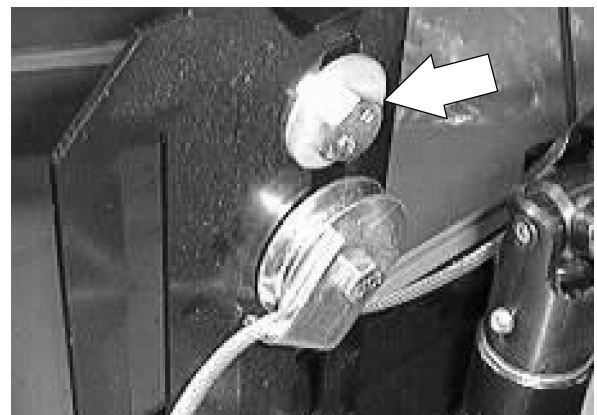

8. Move the pulley mount bracket up or down to achieve the proper side brush pattern. Retighten the hex screw.

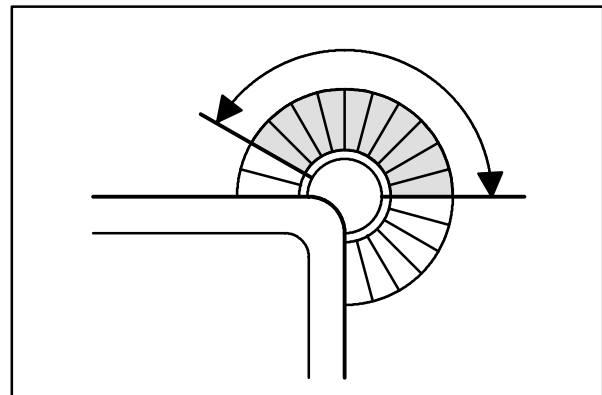

SWEEPING

SIDE BRUSH GUARD

Check the side brush guard after every 200 hours of operation. Replace the brush guard after it begins to show serious wear.



SIDE BRUSH PIVOT

The side brush pivot should be checked for excessive movement after every 200 hours of operation. Torque the front and rear compression springs to reduce excessive movement.

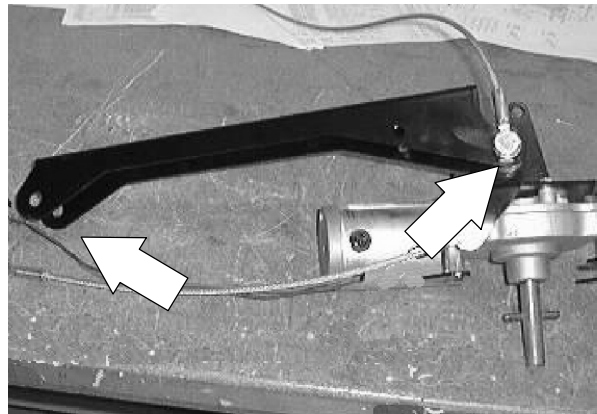

TO REPLACE SIDE BRUSH LIFT CABLE

FOR SAFETY: Before Leaving Or Servicing Machine; Stop On Level Surface, Set Parking Brake.

1. Lower the side brush handle.

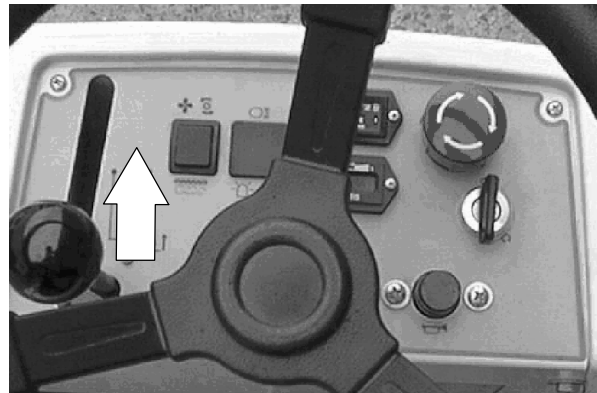

2. Go under the front of the machine near the side brush. Locate the side brush lift cable clevis under the brush pivot hex nut. Remove the nut only. Pull the side brush lift cable off the hex screw.

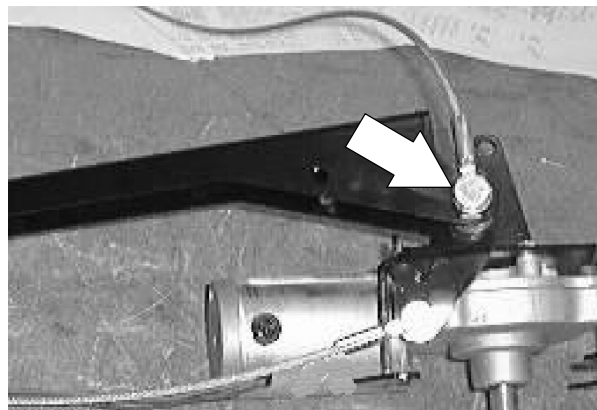

3. Go to the operators compartment. Remove the three cable pulleys, sleeves, and cable clips from the side brush lift assembly. Note the orientation of the cable clips for proper re-assembly.

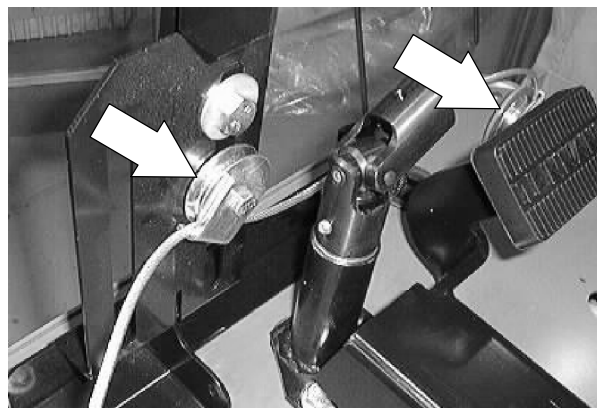

SWEEPING

4. Go up under the instrument panel and remove the hex screw and nut holding the end of the side brush lift cable to the lift handle. Remove the side brush lift cable from the machine.

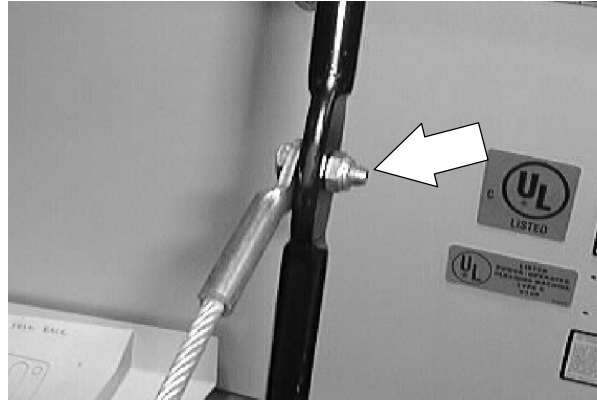

5. Route the new side brush lift cable in the machine.



6. Reinstall the three cable pulleys, sleeves, and cable clips. Make sure the cable clips are in the correct orientation. Tighten the hardware to 18 - 24 Nm (15 - 20 ft lb).

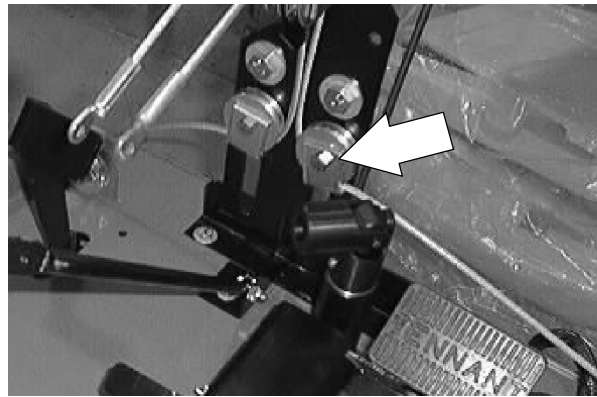

7. Connect the new side brush lift cable to the side brush pivot screw. Hand tighten the hex nut. Cable should pivot on the hardware.

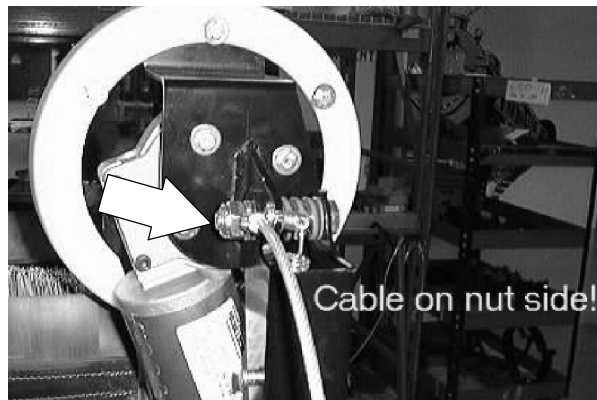

8. Raise the side brush.

SKIRTS AND SEALS

REAR SKIRT

The two rear skirts are located on the bottom rear of the main brush compartment. The vertical skirt should clear the floor up to 2 mm (0.09 in). The recirculation skirt requires no adjustment.

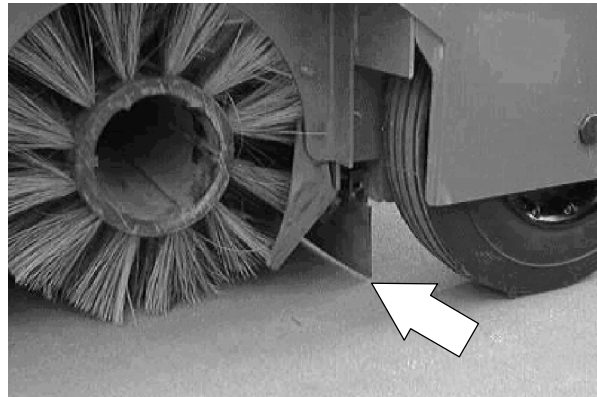

Check the skirts for wear or damage and adjustment daily.

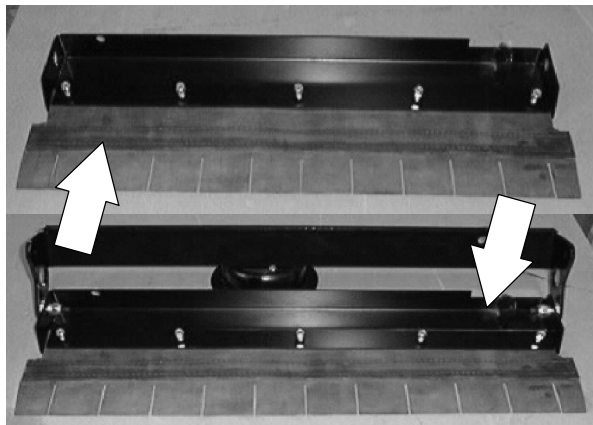

NOTE: The recirculation skirt must be folded in between the brush and the machine frame before the brush door is mounted on for the machine to work properly.

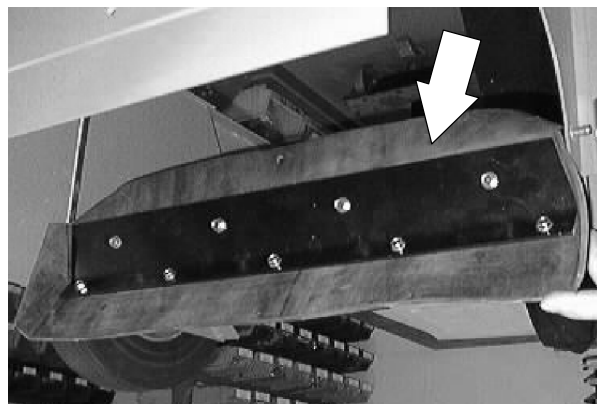

SWEEPING

SIDE SKIRTS

The side skirts are located on both sides of the main brush compartment. The skirts should clear the floor up to 5 mm.

Check the skirts for wear or damage daily.

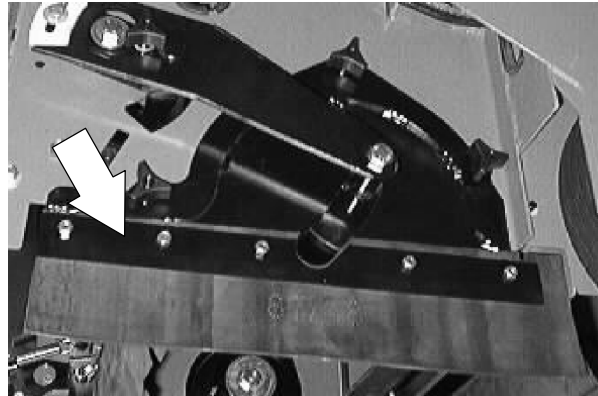

TO ADJUST SIDE SKIRTS

FOR SAFETY: Before Leaving Or Servicing Machine; Stop On Level Surface, Set Parking Brake.

1. Open the LH brush door .

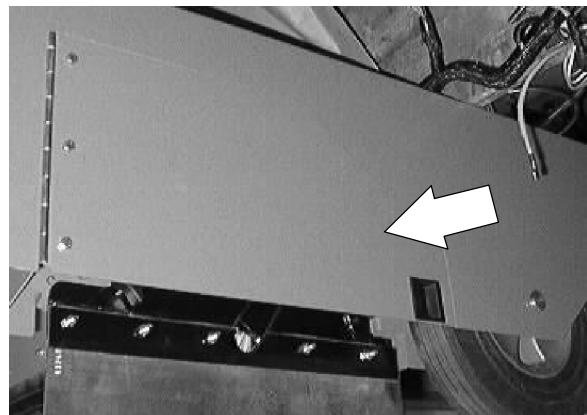

2. Remove the RH brush door.



- Loosen the hardware holding the side skirts to the frame.



- Place a flat washer under the bottom edge of the skirts. Make sure the skirt is touching the washer. Tighten the hardware to 560Ncm.



- Close the LH brush door.

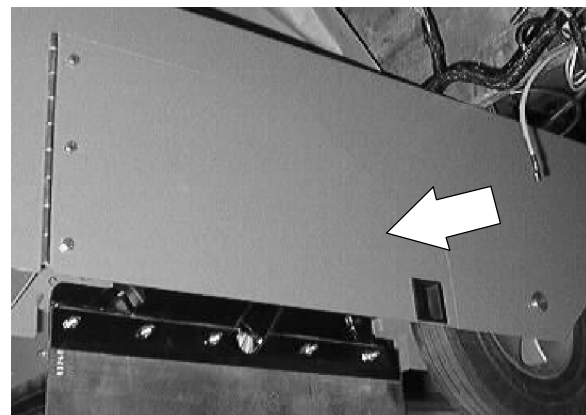

- Reinstall the RH brush door.

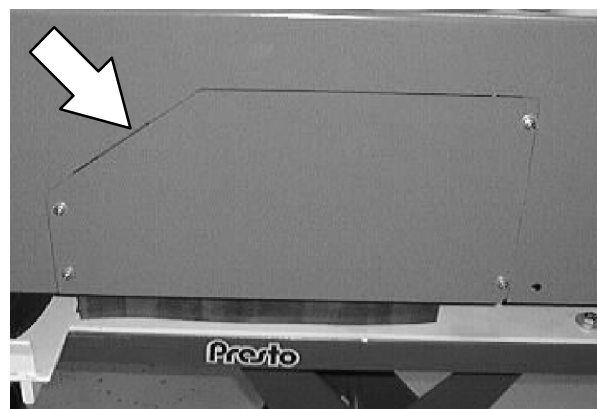

SWEEPING

LARGE DEBRIS TRAP SKIRT

The large debris trap skirt is located along the front of the main brush. This skirt is raised and lowered by the large debris trap pedal, allowing larger debris to be trapped and swept up into the hopper.

This skirt should be adjusted so it touches the floor and is curled back, toward the main brush (**curl back should be 3/4 inch \pm 1/4 inch**). Sweeping performance will be adversely affected if this skirt does not contact the floor.

Check the skirt for wear or damage after every 100 hours of operation.

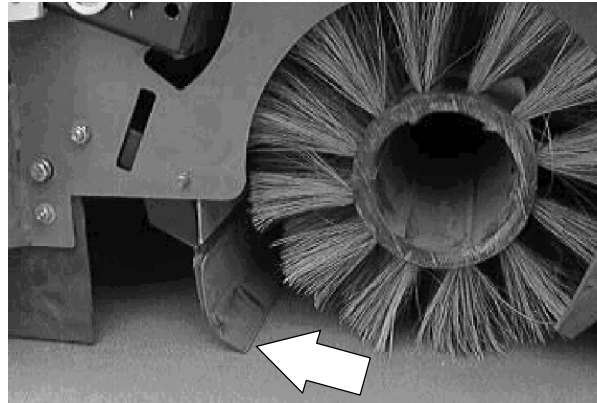

TO ADJUST FRONT FLAP SKIRT

FOR SAFETY: Before Leaving Or Servicing Machine; Stop On Level Surface, Set Parking Brake.

1. The front flap skirt must roll to the rear of the machine .75 in (3/4 in) \pm .125 in (1/8 in)

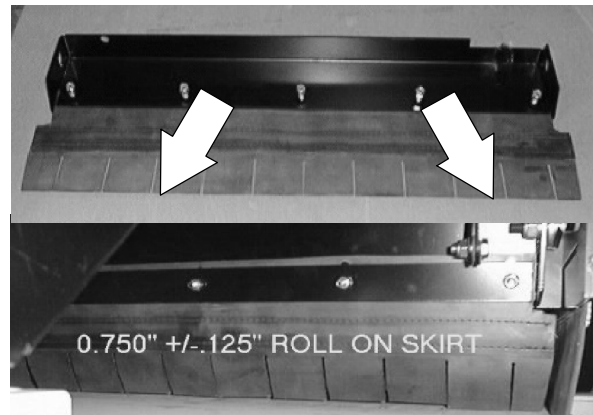

HOPPER SEALS

The hopper seals are located along the back of the main brush. The hopper rests on the seals when the hopper is setting in proper sweeping position.

Check the seals for wear or damage after every 100 hours of operation.

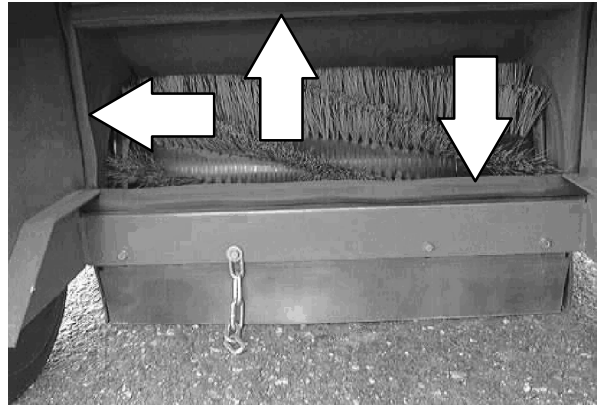

The upper hopper seal is located above the hopper on the bottom of the filter weldment. Check the seal for wear or damage after every 100 hours of operation.

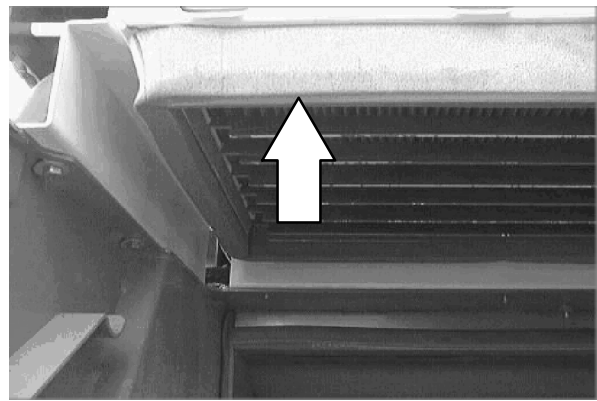

SWEEPING

TO ADJUST RECIRCULATING SKIRT CAM.

FOR SAFETY: Before Leaving Or Servicing Machine; Stop On Level Surface, Set Parking Brake.

1. Pull the brush lift handle forward.

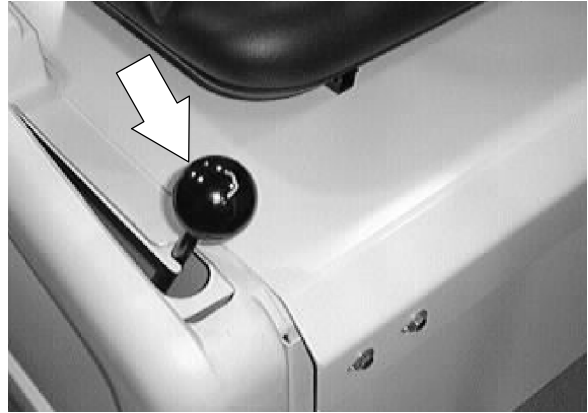

2. Lift the recirculation cam until it hits the frame.

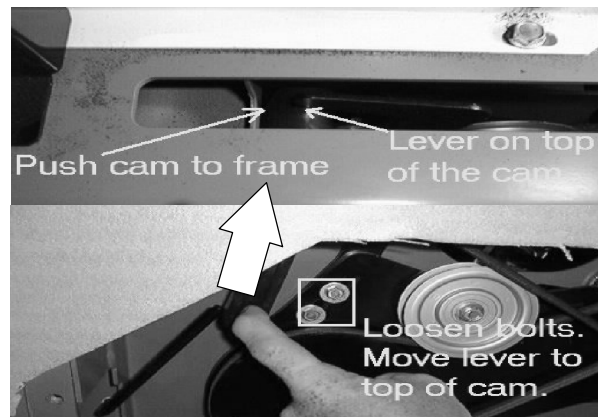

3. Slowly lower the brush lift handle to the down position.



4. If the cam follows the lever, do NOT adjust.

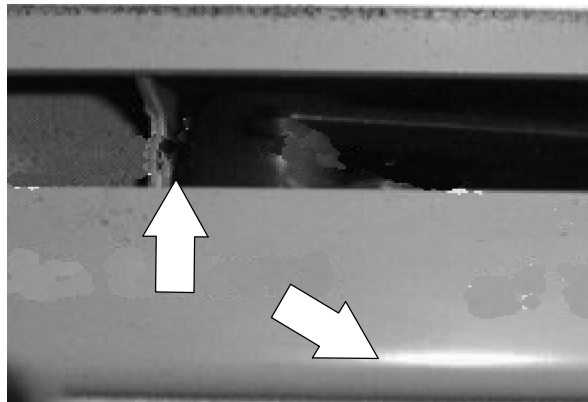

5. If the lever does not lower, Loosen the hardware and move the lever.

NOTE: The lever must not move to the front of the cam.

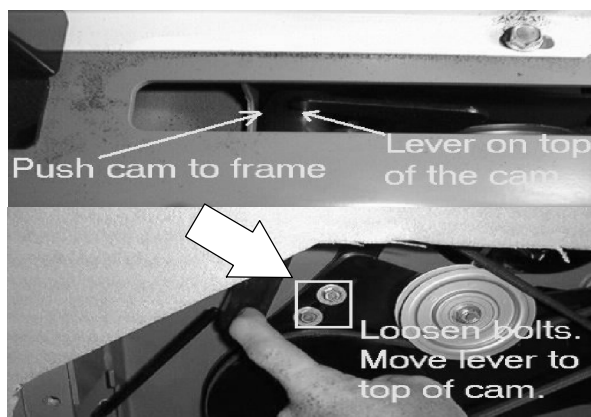

VACUUM FAN

The vacuum system pulls dust and air into the hopper through the Instant Access™ filter. The vacuum fan is driven off the engine jack shaft.

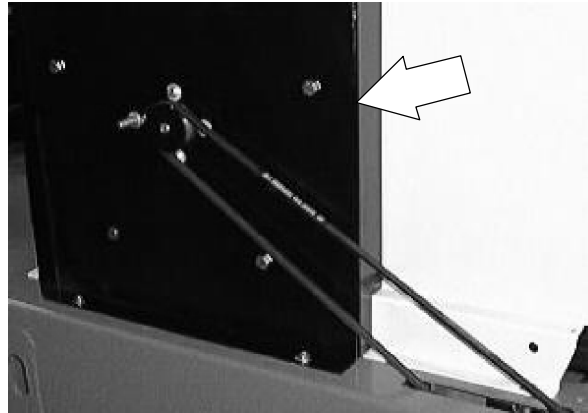

VACUUM FAN BELT

Check the vacuum fan belt tension and wear after every 200 hours of operation. The correct tension is when the belt deflects 8.38 mm (0.33 in) from a force of .42 kg (.90 to .95 lb) at belt midpoint.

 **WARNING: Moving belt and fan. Keep away.**

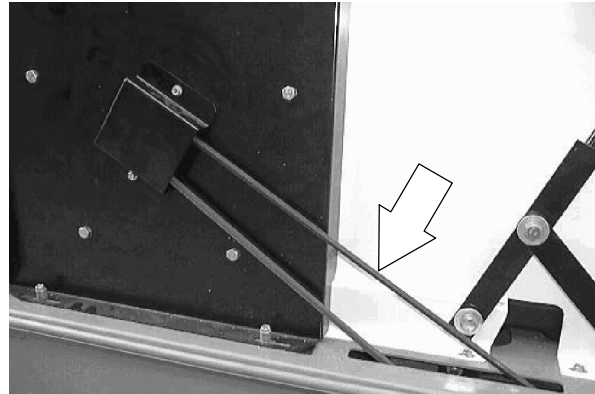

TO REPLACE VACUUM FAN DRIVE BELT

FOR SAFETY: Before Leaving Or Servicing Machine; Stop On Level Surface, Set Parking Brake.

1. To access the vacuum fan drive belt, remove the right hand side panel. Start by lifting up on the panel, pop the brush lift slot over the black knob, then move the panel backward and off the machine.



2. Remove the four screws holding the right hand brush door to the machine frame. Remove the right hand side brush door.

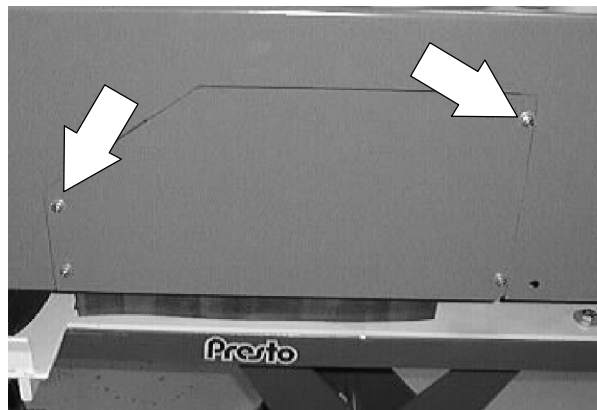

3. Loosen the four hex screws holding the vacuum fan housing to the machine frame.

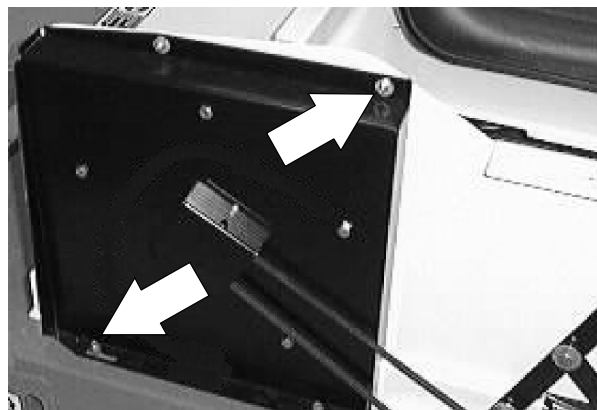

SWEEPING

4. Push the vacuum fan assembly forward in the slots to loosen the vacuum fan V-belt.



5. Remove the two hex screws holding the cover over the V-belt pulley. Remove the cover.

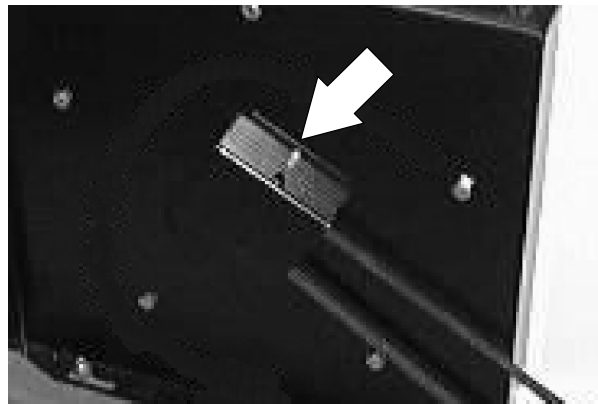

6. Remove the vacuum fan V-belt from both pulleys. Remove the old V-belt from the machine.

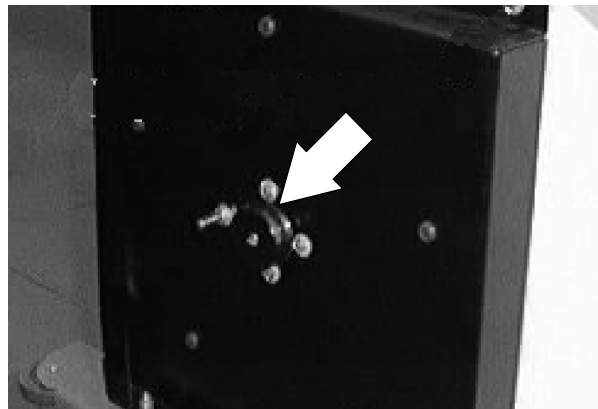

7. Install the new vacuum fan V-belt over both pulleys.

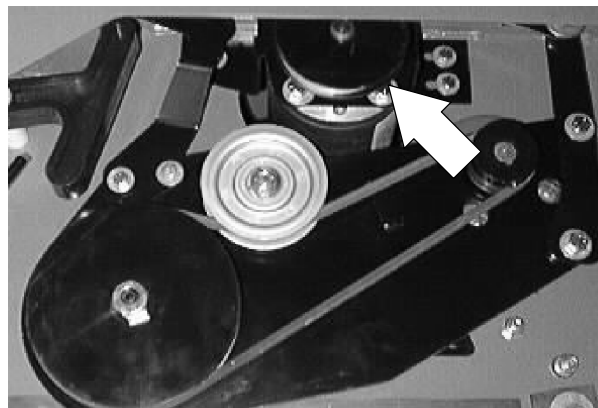

- Pull the vacuum fan assembly toward the back of the machine to tighten the V-belt. The correct tension is when the belt deflects 8.38 mm (0.33 in) from a force of .42 kg (.90 to .95 lb) at belt midpoint. Tighten the screws hand tight.

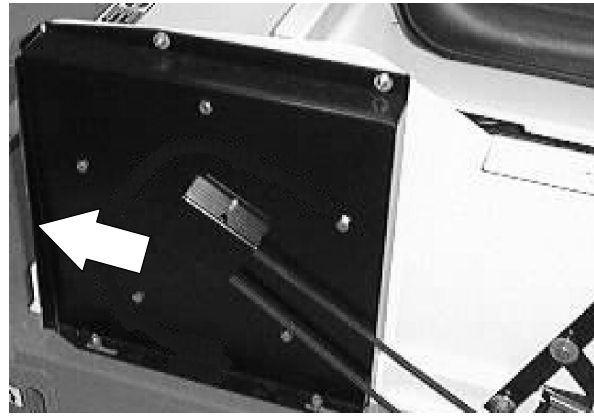

- Reinstall the V-belt cover. Tighten the two screws hand tight.

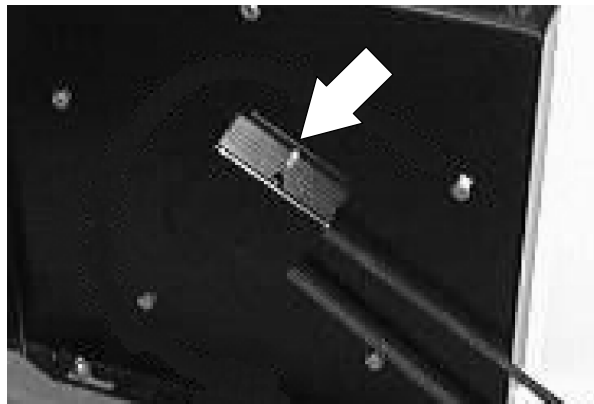

- Reinstall the right hand side brush door.

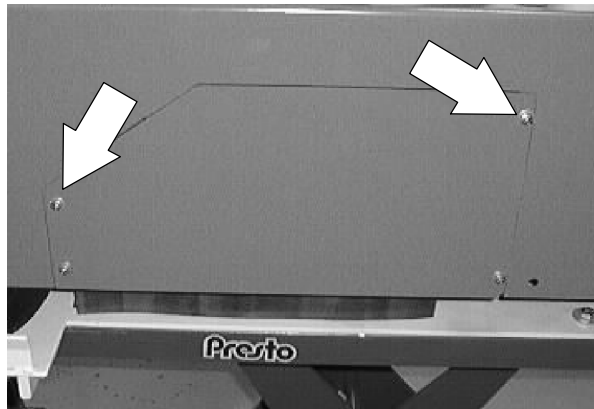

- Reinstall the right hand machine cover.



- Operate the machine. Check the vacuum fan for proper operation.

TO TENSION VACUUM FAN DRIVE BELT

FOR SAFETY: Before Leaving Or Servicing Machine; Stop On Level Surface, Set Parking Brake.

1. To access the vacuum fan drive belt, remove the right hand side panel. Start by lifting up on the panel, pop the brush lift slot over the black knob, then move the panel backward and off the machine.



2. Loosen the four hex screws holding the vacuum fan housing to the machine frame.

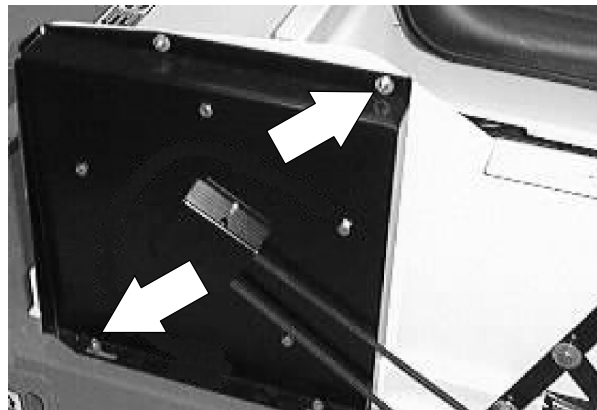

3. Pull the vacuum fan assembly toward the back of the machine to tighten the V-belt. The correct tension is when the belt deflects 8.38 mm (0.33 in) from a force of .42 kg (.90 to .95 lb) at belt midpoint.

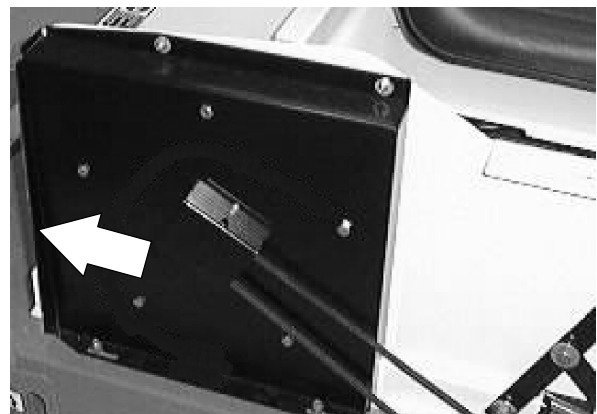

4. Tighten the four mounts screws hand tight.

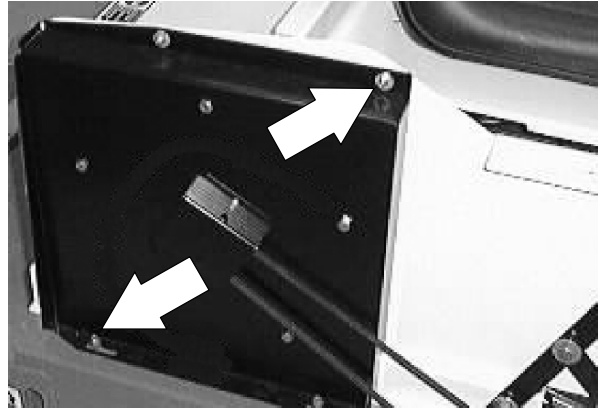

5. Reinstall the right hand machine cover.



6. Operate the machine. Check the vacuum fan for proper operation.



TO REPLACE VACUUM FAN IMPELLER

FOR SAFETY: Before Leaving Or Servicing Machine; Stop On Level Surface, Set Parking Brake.

1. To access the vacuum fan drive belt, remove the right hand side panel. Start by lifting up on the panel, pop the brush lift slot over the black knob, then move the panel backward and off the machine.



2. Loosen the four hex screws holding the vacuum fan housing to the machine frame.

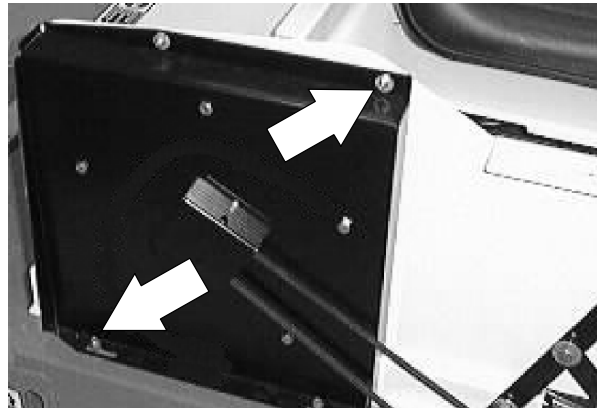

3. Push the vacuum fan assembly forward in the slots to loosen the vacuum fan V-belt.



4. Remove the two hex screws holding the cover over the V-belt pulley. Remove the cover.

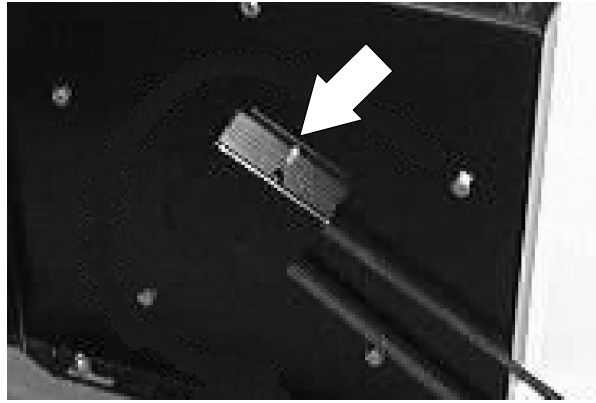

5. Remove the vacuum fan V-belt from the vacuum fan sheave.

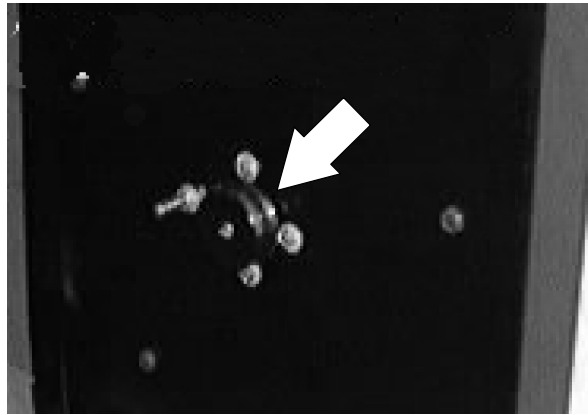

6. Remove the four hex nuts holding the vacuum fan assembly to the machine. Remove the assembly from the machine. *Make sure to retain the two steel sleeves from the bottom two hex screws.*

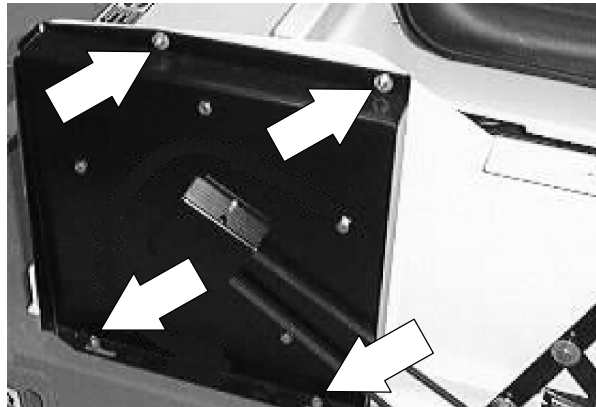

7. Place the assembly on a work bench with the vacuum fan inlet plate facing up.

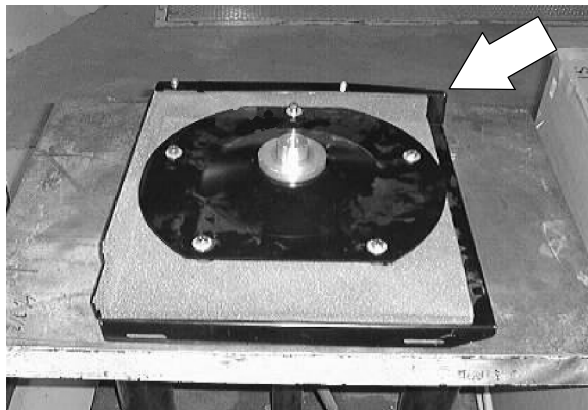

SWEEPING

8. Remove the five hex screws and nuts holding the vacuum fan inlet plate to the bearing housing plate. Remove the inlet plate from the housing. *Make sure to retain the five steel sleeves.*

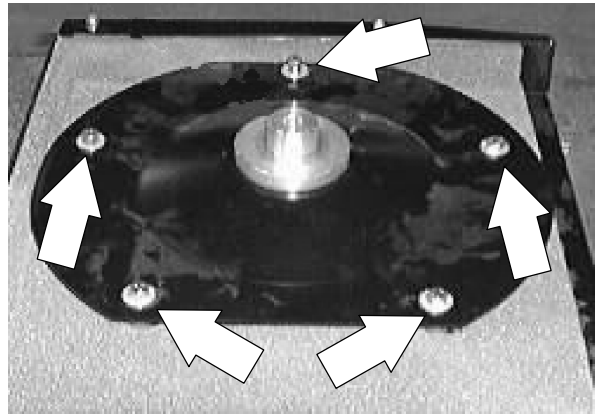

9. Remove the nyloc nut holding the vacuum fan impeller to the fan shaft. Pull the impeller off the shaft. *Make sure to retain the square key.*

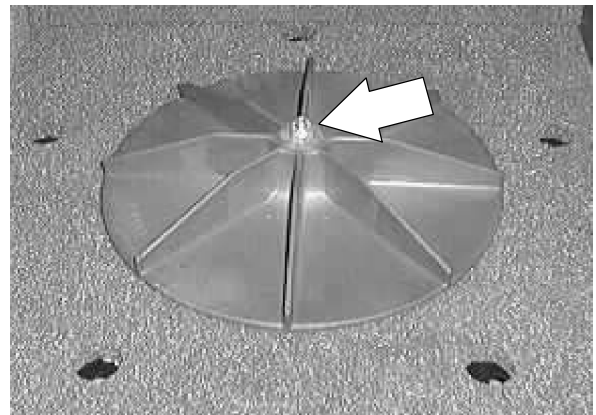

10. Install the new vacuum fan impeller onto the fan shaft. Make sure to reinstall the square key on the fan shaft.

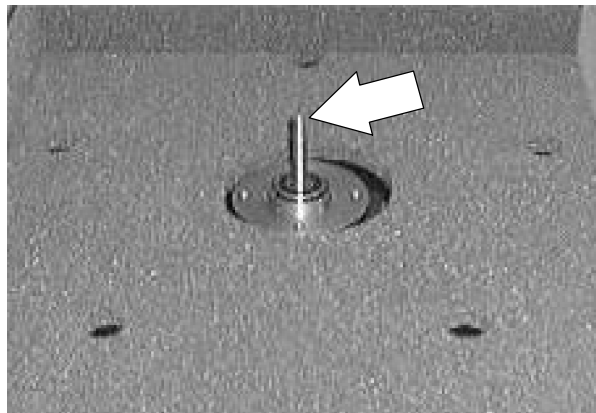

11. Reinstall the nyloc nut onto the fan shaft. Tighten to 11 - 14 Nm (7 - 10 ft lb).

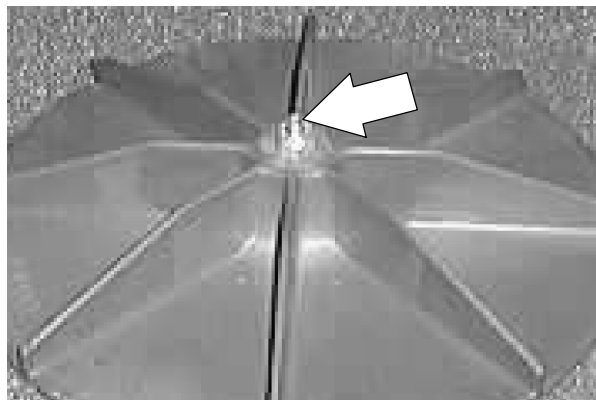

12. Reinstall the vacuum fan inlet plate onto the bearing housing plate. Reinstall the five steel sleeves, hex screws, and nuts. Center the hole in the plate over the impeller fins. Tighten the hardware to 18 - 24 Nm (15 - 20 ft lb).

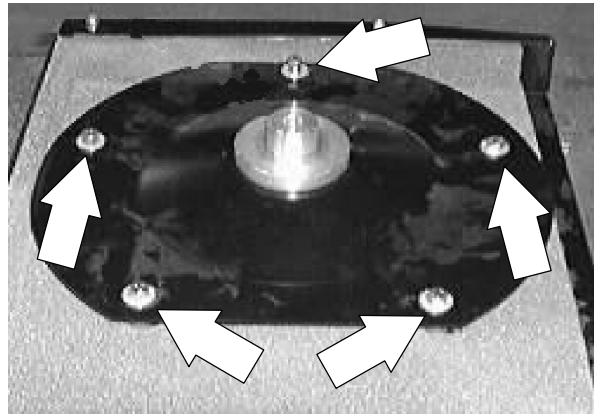

13. Position the vacuum fan assembly onto the right side of the machine. Reinstall the four hex screws and nuts. Make sure to install the two steel sleeves on the bottom two hex screws. Leave the hardware loose for now.

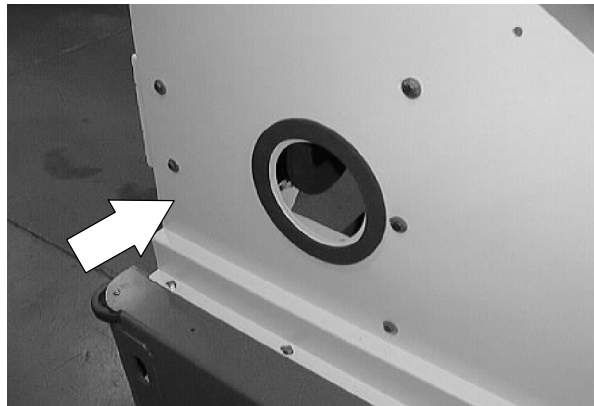

14. Install the vacuum fan V-belt over the vacuum fan sheave.

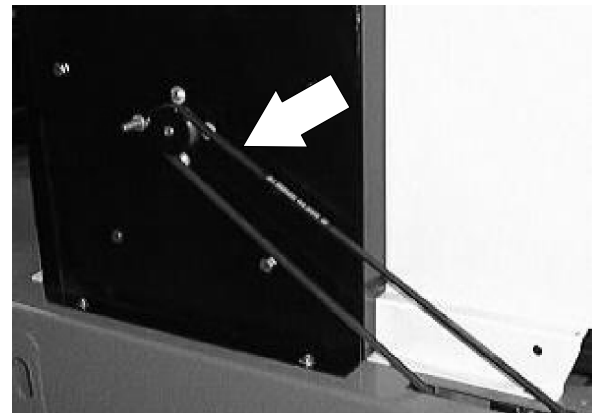

15. Pull the vacuum fan assembly toward the back of the machine to tighten the V-belt. The correct tension is when the belt deflects 8.38 mm (0.33 in) from a force of .42 kg (.90 to .95 lb) at belt midpoint.

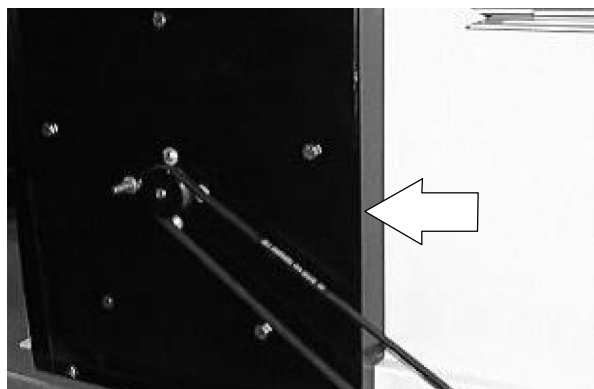

16. Tighten the four mounts screws hand tight.

SWEEPING

17. Reinstall the V-belt cover. Tighten the two screws hand tight.

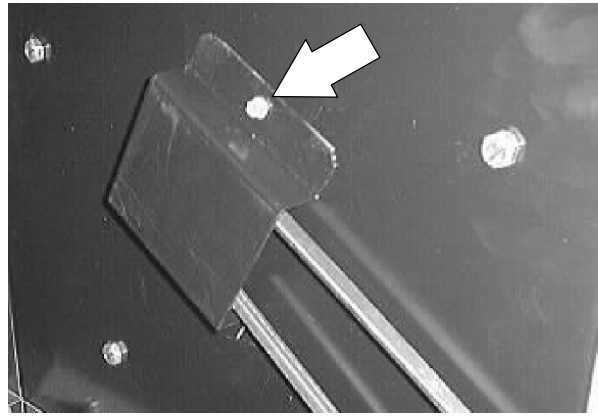

18. Reinstall the right hand machine cover.

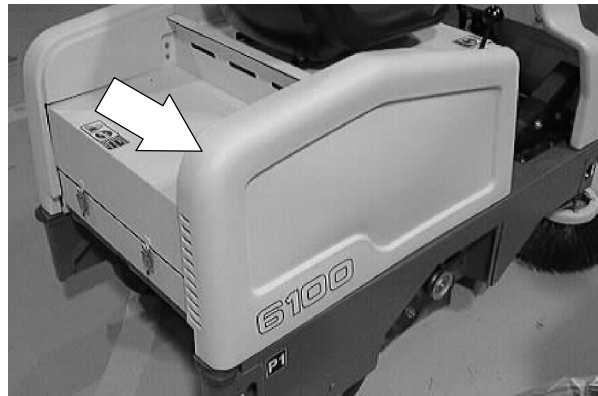

19. Operate the machine. Check the vacuum fan for proper operation.



TO REPLACE VACUUM FAN IMPELLER BEARINGS

FOR SAFETY: Before Leaving Or Servicing Machine; Stop On Level Surface, Set Parking Brake.

1. To access the vacuum fan assembly, remove the right hand side panel. Start by lifting up on the panel, pop the brush lift slot over the black knob, then move the panel backward and off the machine.



2. Loosen the four hex screws holding the vacuum fan housing to the machine frame.

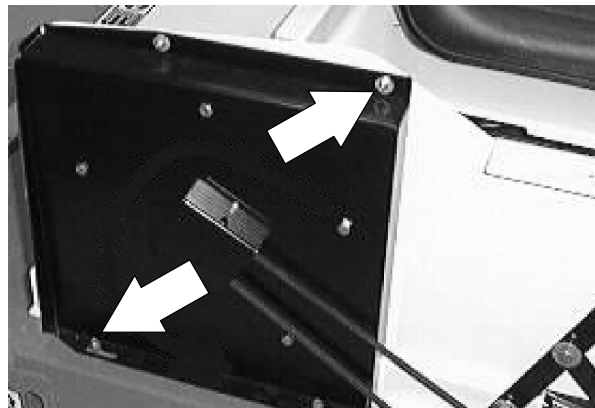

3. Push the vacuum fan assembly forward in the slots to loosen the vacuum fan V-belt.



SWEEPING

4. Remove the two hex screws holding the cover over the V-belt pulley. Remove the cover.

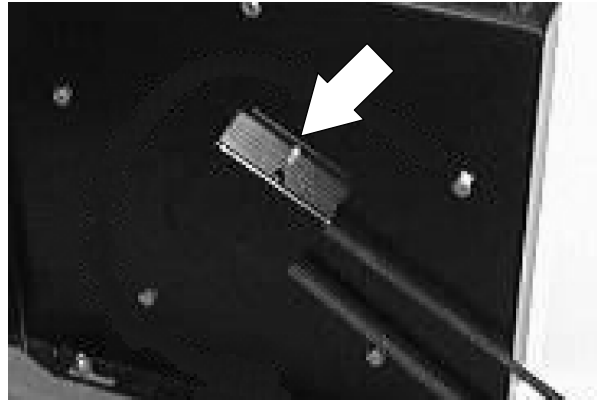

5. Remove the vacuum fan V-belt from the vacuum fan sheave.

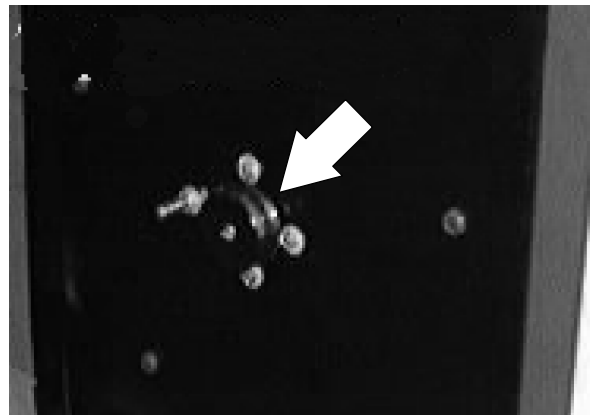

6. Remove the four hex nuts holding the vacuum fan assembly to the machine. Remove the assembly from the machine. *Make sure to retain the two steel sleeves from the bottom two hex screws.*

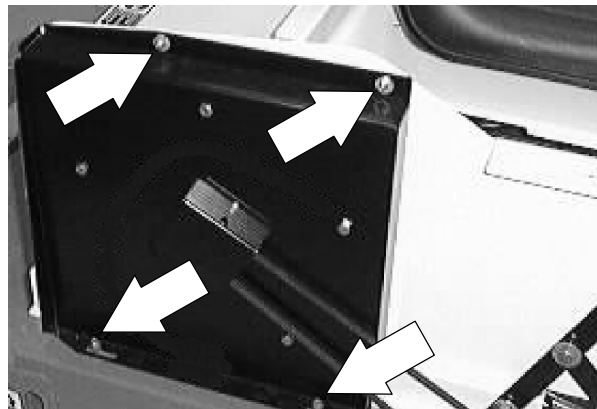

7. Place the assembly on a work bench with the vacuum fan inlet plate facing up.

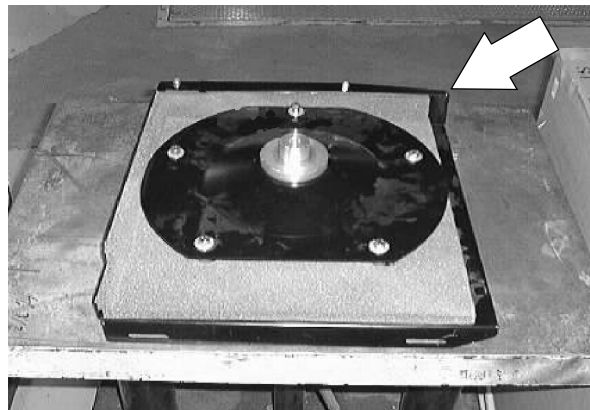

8. Remove the five hex screws and nuts holding the vacuum fan inlet plate to the bearing housing plate. Remove the inlet plate from the housing. *Make sure to retain the five steel sleeves.*

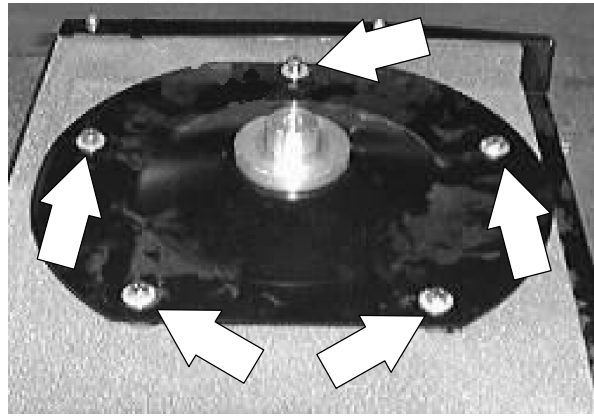

9. Remove the nyloc nut holding the vacuum fan impeller to the fan shaft. Pull the impeller off the shaft. *Make sure to retain the square key.*

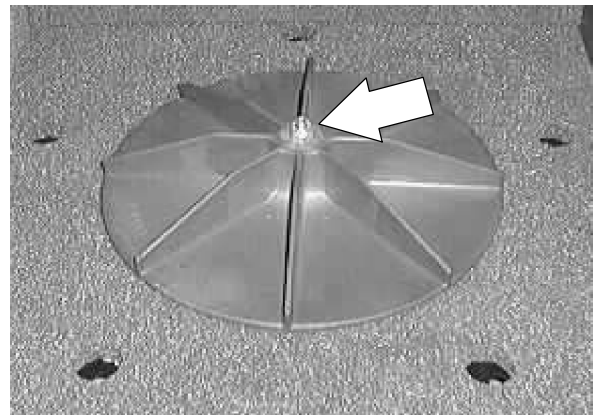

10. Loosen the two set screws holding the V-belt pulley to the fan shaft. Remove the pulley.



11. Remove the four hex screws holding the vacuum fan bearing assembly to the bearing plate. Remove the bearing assembly.

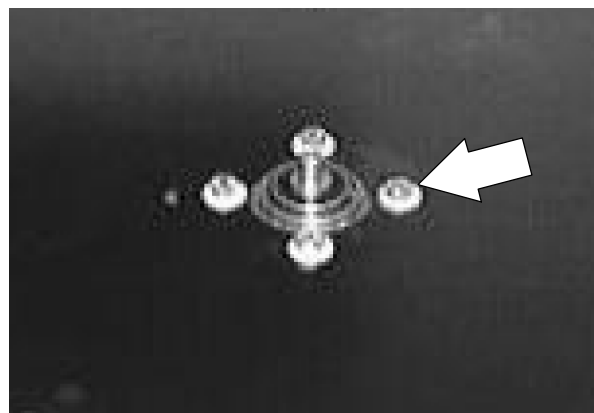

SWEEPING

12. Use an arbor press to remove the fan shaft and two bearings from the housing.

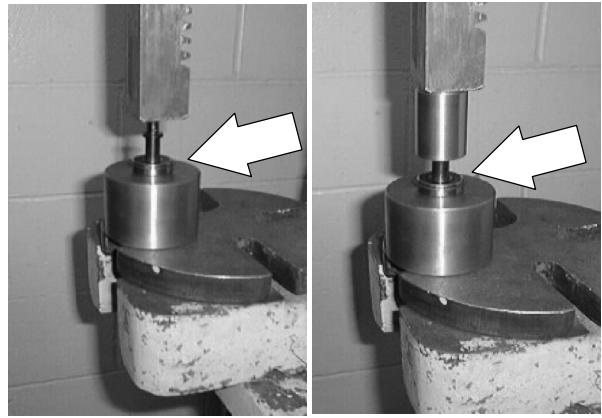

13. Use the arbor press to install the new bearings **and spacer washer** (between bearings) into the housing. *The short end of fan shaft is on the side of housing with the thin flange. The long end of fan shaft is on the side of the housing with the wide flange.*

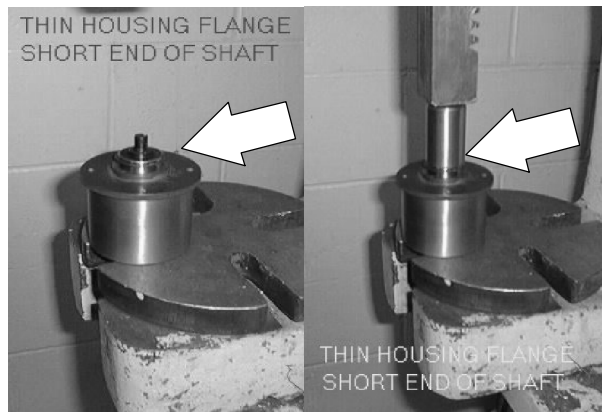

NOTE: Make sure the bearings are pressed down tight. The fan will be noisy if there is any play in the bearings. The retaining rings must be tight to the housing.

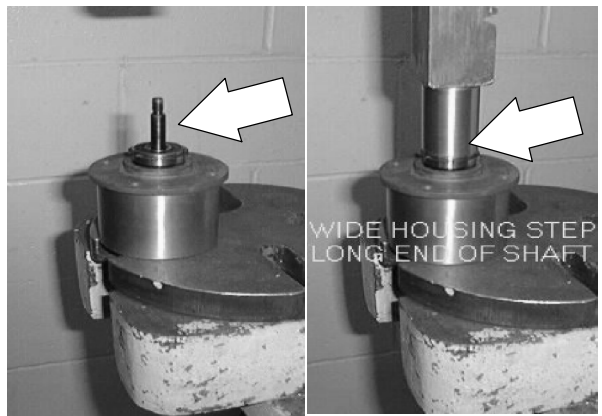

14. Reinstall the bearing housing onto the bearing housing plate. The long end of the shaft is on the side with the sound foam. Reinstall the four hex screws and washers. Tighten to 8 - 10 Nm (6 - 8 ft lb).

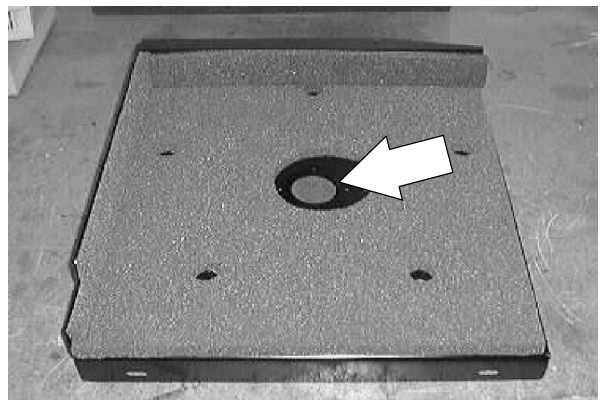

15. Reinstall the V-belt pulley on the short end of the fan shaft. *The recessed side of the pulley goes to the inside.* Hand tighten the set screws tight.

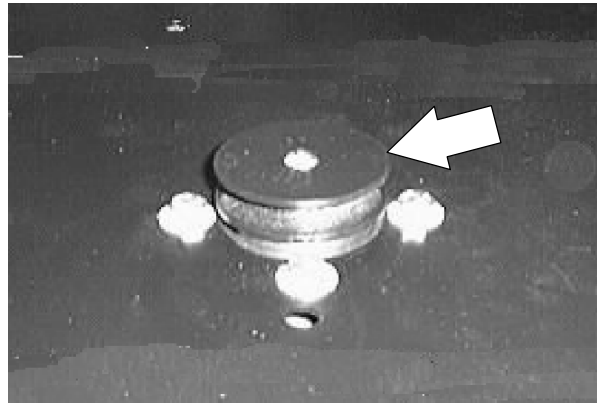

16. Reinstall the vacuum fan impeller onto the fan shaft. Make sure to reinstall the square key on the fan shaft.

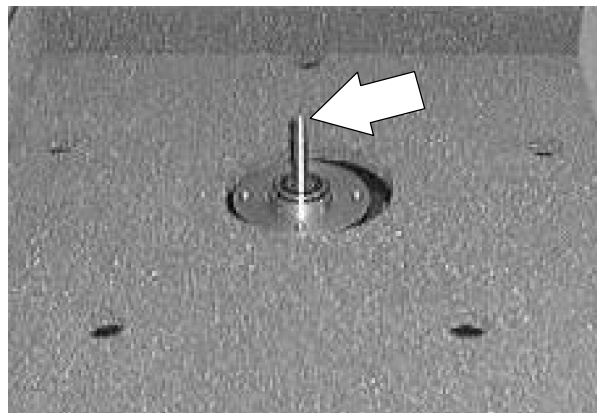

17. Reinstall the nyloc nut onto the fan shaft. Tighten to 11 - 14 Nm (7 - 10 ft lb).

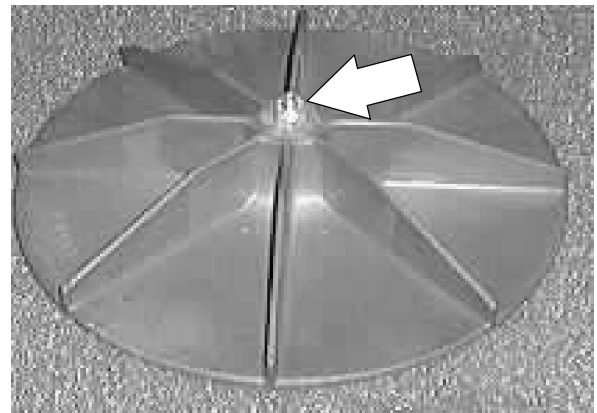

18. Reinstall the vacuum fan inlet plate onto the bearing housing plate. Reinstall the five steel sleeves, hex screws, and nuts. Center the hole in the plate over the impeller fins. Tighten the hardware to 18 - 24 Nm (15 - 20 ft lb).

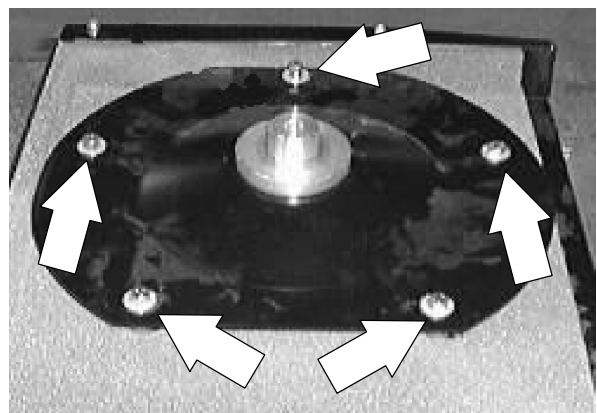

SWEEPING

19. Position the vacuum fan assembly onto the right side of the machine. Reinstall the four hex screws and nuts. Make sure to install the two steel sleeves on the bottom two hex screws. Leave the hardware loose for now.

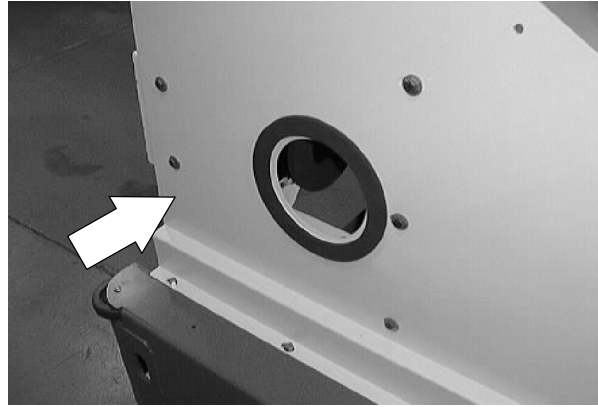

20. Install the vacuum fan V-belt over the vacuum fan sheave.

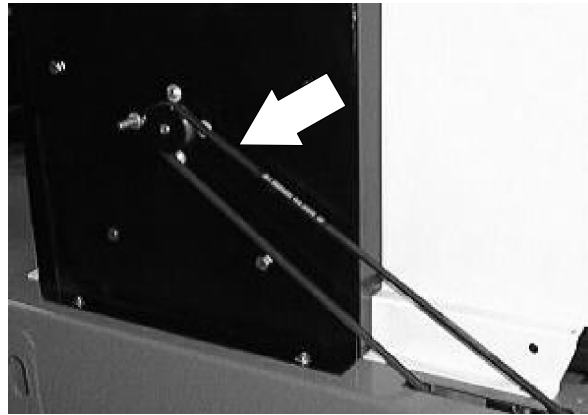

21. Pull the vacuum fan assembly toward the back of the machine to tighten the V-belt. The correct tension is when the belt deflects 8.38 mm (0.33 in) from a force of .42 kg (.90 to .95 lb) at belt midpoint.

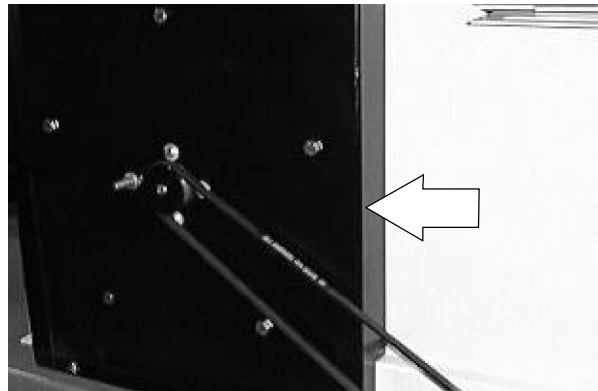

22. Tighten the four mounts screws hand tight.

23. Reinstall the V-belt cover. Tighten the two screws hand tight.

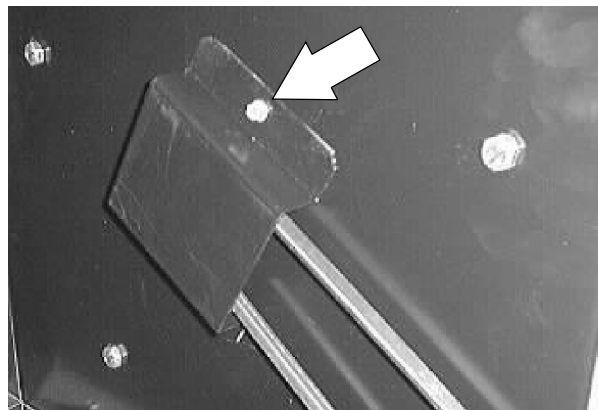

24. Reinstall the right hand machine cover.



25. Operate the machine. Check the vacuum fan for proper operation.



SWEEPING

MACHINE TROUBLESHOOTING

Problem	Cause	Remedy
Excessive dusting	Vacuum fan off	Press the main brush, vacuum and filter shaker switch to the on position
	Brush skirts and dust seals worn, damaged, out of adjustment	Replace or adjust brush skirts or dust seals
	Hopper dust filter clogged	Shake and/or clean or replace dust filter
	Vacuum hose damaged	Replace vacuum hose
	Vacuum fan failure	Contact Tennant service personnel
Poor sweeping performance	Brush bristles worn	Replace brushes
	Main and side brushes not adjusted properly	Adjust main and side brushes
	Debris caught in main brush drive mechanism	Remove debris from drive mechanism
	Main brush drive failure	Contact Tennant service personnel
	Side brush drive failure	Contact Tennant service personnel
	Hopper full	Empty hopper
	Hopper lip skirts worn or damaged	Replace lip skirts
	Wrong sweeping brush	Contact Tennant representative for recommendations
	Large debris trap damaged	Repair or replace large debris trap
No machine power	Power kill switch on	Turn kill switch clockwise until it pops up. Turn machine off and on.
	Low battery power	Check and charge batteries
	Hopper dust filter clogged	Shake and/or clean or replace dust filter
Low machine power	Low battery power	Check and charge batteries.
Machine does not propel	Power kill switch on	Turn kill switch clockwise until it pops up. Turn machine off and on.
	Low or dead batteries	Check and charge batteries
	Operator not in seat	Sit in operator seat
Vacuum Wand does not come on	Auto switch not adjusted	Adjust switch
	Low battery power	Check and charge batteries
	Wand holding bracket bent	Straighten bracket

CONTENTS

	Page
INTRODUCTION	4-3
ELECTRICAL SYSTEM	4-4
BATTERIES	4-4
TO CHARGE BATTERIES	4-5
TO REPLACE BATTERIES	4-8
INSTRUMENT PANEL	4-12
TO ACCESS INSTRUMENT PANEL	4-12
TO REPLACE INSTRUMENT PANEL	
CIRCUIT BREAKER	4-16
ELECTRICAL PANEL	4-21
TO ACCESS ELECTRICAL PANEL .	4-21
TO REPLACE PROPEL	
CONTROLLER	4-24
CIRCUIT BREAKERS	4-27
TO REPLACE ELECTRICAL PANEL	
CIRCUIT BREAKER	4-28
FUSES	4-31
TO REPLACE ELECTRICAL PANEL	
40 AMP FUSE	4-31
DIRECTIONAL PEDAL	4-34
TO REMOVE DIRECTIONAL PEDAL	
ASSEMBLY	4-34
TO INSTALL DIRECTIONAL PEDAL	
ASSEMBLY	4-36
TO REPLACE DIRECTIONAL PEDAL	
POTENTIOMETER	4-38
TO SET POTENTIOMETER	
NEUTRAL	4-41
ELECTRIC MOTORS	4-44
TO REPLACE FRONT DRIVE WHEEL	
MOTOR	4-44
TO REPLACE MAIN BRUSH	
MOTOR	4-52
TO REPLACE VACUUM FAN	
MOTOR	4-59
TO REPLACE SIDE BRUSH	
MOTOR	4-65
ELECTRICAL SCHEMATIC	4-68
WIRE HARNESS	4-70
TROUBLESHOOTING	4-73

INTRODUCTION

The 6100E electrical system consists of the batteries, instrument panel, drive motor, switches, relays, and circuit breakers.

ELECTRICAL SYSTEM

The model 6100E is a battery powered, all electric machine. The batteries are used to power the front drive motor, vacuum fan motor, main brush motor, side brush motor, and the filter shaker.

BATTERIES

The batteries are unique in that they hold their power for long periods of time. The lifetime of the batteries is limited by the number of charges the batteries receive. To get the most life from the batteries, charge them when the last battery discharge indicator segment flashes (20% charge left). Use an automatic charger with the proper rating for the batteries.

Periodically clean the top surface of the batteries and the terminals, and check for loose connections. Use a strong solution of baking soda and water. Brush the solution sparingly over the battery tops, terminals, and cable clamps. Do not allow any baking soda solution to enter the batteries. Use a wire brush to clean the terminal posts and the cable connectors. After cleaning, apply a coating of clear battery post protectant to the terminals and the cable connectors. Keep the tops of the batteries clean and dry.

Keep all metallic objects off the top of the batteries, which may cause a short circuit. Replace any worn or damaged wires.

Check the electrolyte level in each battery cell before and after charging, and after every 50 hours of operation. Do not charge the batteries unless the fluid is slightly above the battery plates. If needed, add just enough distilled water to cover the plates. Never add acid to the batteries. Do not overfill. Always keep the battery caps on, except when adding water or taking hydrometer readings.

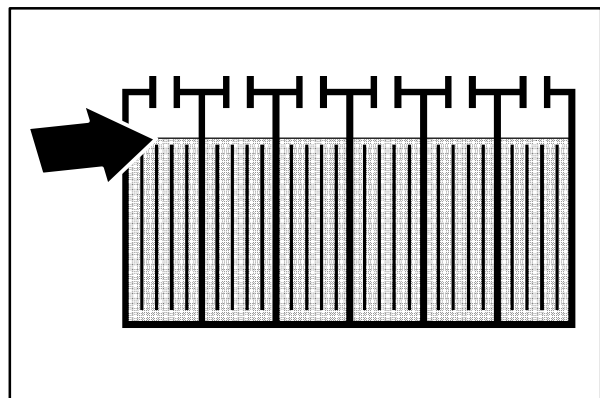

Measuring the specific gravity, using a hydrometer, is a way to determine the charge level and condition of the batteries. If one or more of the battery cells test lower than the other battery cells (0.050 or more), the cell is damaged, shorted, or is about to fail.

NOTE: Do not take readings immediately after adding distilled water. If the water and acid are not thoroughly mixed, the readings may not be accurate. Check the hydrometer readings against the following chart to determine the remaining battery charge level:

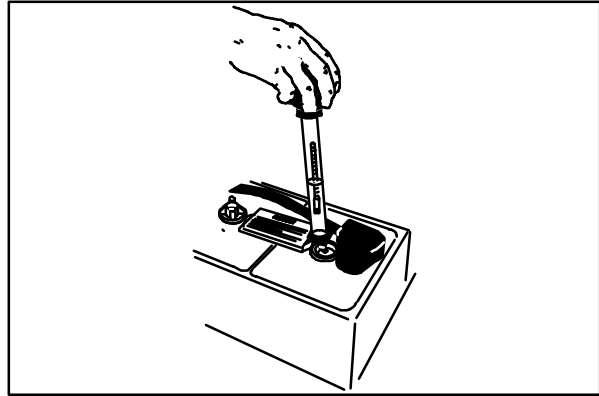

04380

Spec. Gravity at 27° C (80° F)	
Charge Level	220 AH Battery
100 %	1.265
75 %	1.223
50 %	1.185
25 %	1.148
Discharged	1.110

NOTE: If the readings are taken when the battery electrolyte is any temperature other than shown, the reading must be temperature corrected. Add or subtract to the specific gravity reading 0.004, 4 points, for each 6° C (10° F) above or below 25° C (77° F).

TO CHARGE BATTERIES

1. Drive the machine to a flat, dry surface in a well-ventilated area.
2. Stop the machine, set the parking brake and turn the machine power off.

FOR SAFETY: Before leaving or servicing machine, stop on level surface, set parking brake, turn off machine, and remove key.

3. Open the seat support.

ELECTRICAL

4. Check the water level in all the battery cells.

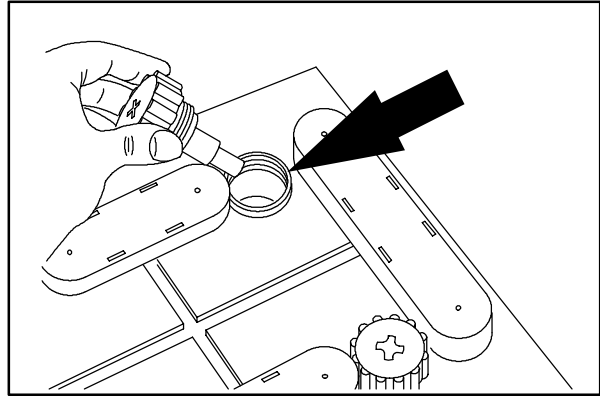

5. If the level is low, add just enough distilled water to cover the battery plates. **DO NOT OVERFILL.** The batteries can overflow during charging due to expansion.

NOTE: Make sure the battery caps are in place while charging.

FOR SAFETY: When maintaining or servicing machine, avoid contact with battery acid.

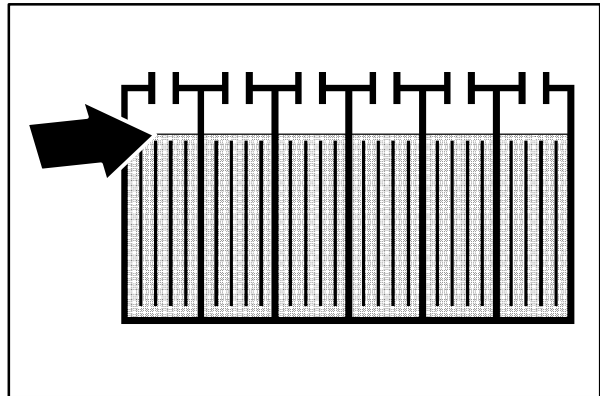

6. Unplug the battery connector from the machine connector.

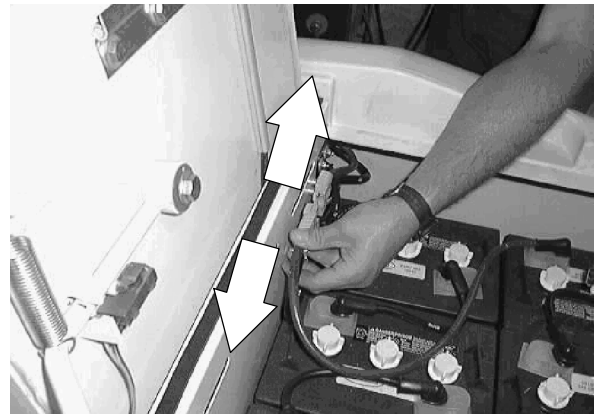

7. Plug the connector from the batteries into the battery charger connector.

⚠ WARNING: Batteries emit hydrogen gas. Explosion or fire can result. Keep sparks and open flame away. Keep covers open when charging.

NOTE: Plug the charger connector into connector that runs to the batteries. Do not plug charger into mounted connector. Damage may occur to the machine.

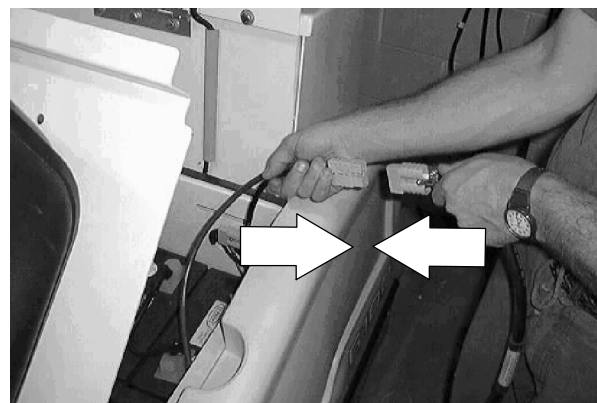

NOTE: If the red "ABNORMAL CYCLE" lamp lights when the batteries are plugged into the TENNANT charger, this indicates that something is wrong with the battery. The charger can not charge the battery when this happens.

8. The Tennant charger will start automatically. When the batteries are fully charged, the Tennant charger will automatically turn off.

NOTE: Use a charger with the proper rating for the batteries to prevent damage to the batteries or reduce the battery life.

NOTE: If the charger needs to be disconnected from the machine before the batteries are fully charged and the charger has not automatically shut off, turn off the charger before disconnecting it.

9. After the charger has turned off, unplug the charger connector from the battery connector on the machine.

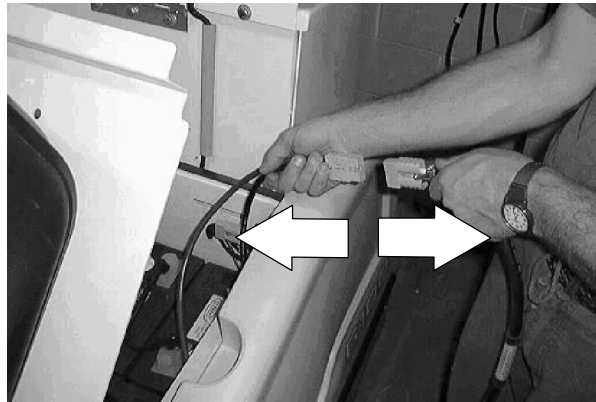

10. Reconnect the battery connector to the machine connector.
11. Check the electrolyte level in each battery cell. Add just enough distilled water to bring the electrolyte level up to the bottom of the fill rings.

FOR SAFETY: When maintaining or servicing machine, avoid contact with battery acid.

12. Close the seat support.



TO REPLACE BATTERIES

FOR SAFETY: Before Leaving Or Servicing Machine; Stop On Level Surface, Set Parking Brake.

1. Open the seat support and engage the prop rod.



2. Disconnect the machine batteries.

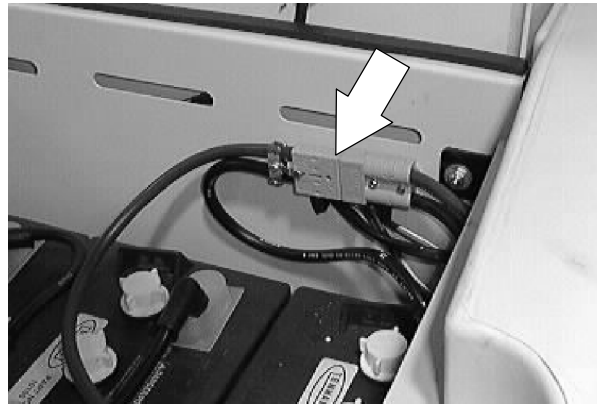

3. Remove the five small battery cables from the batteries.

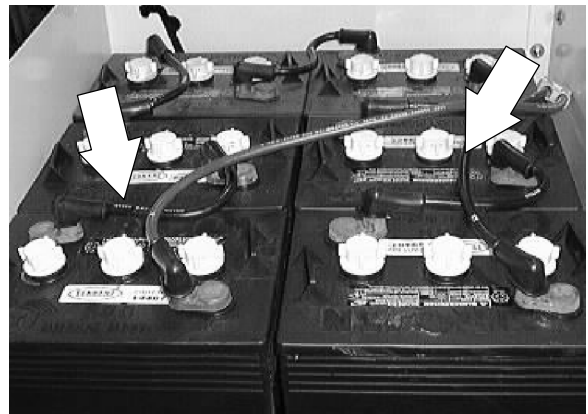

4. Disconnect the connector assembly from the batteries.

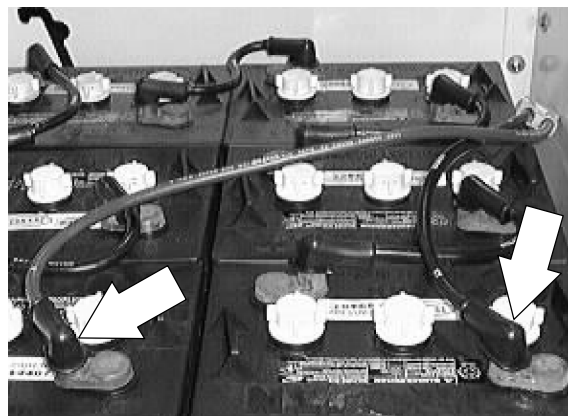

5. Remove the three batteries nearest the rear of the machine first by lifting with the lifting loop at each end of the battery



6. Pull the three batteries nearest the front of the machine toward the rear of the battery tray. Remove these batteries next.

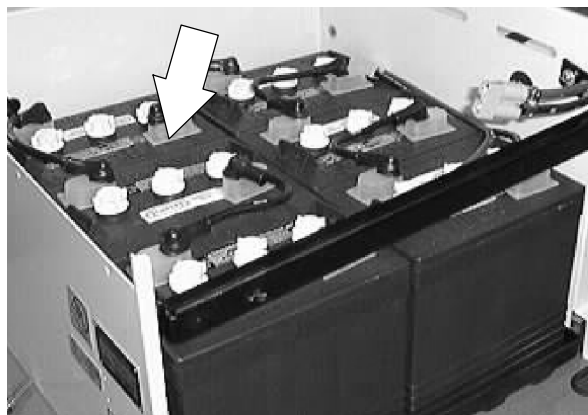

7. Install the front three batteries first. Push these batteries toward the front of the machine.

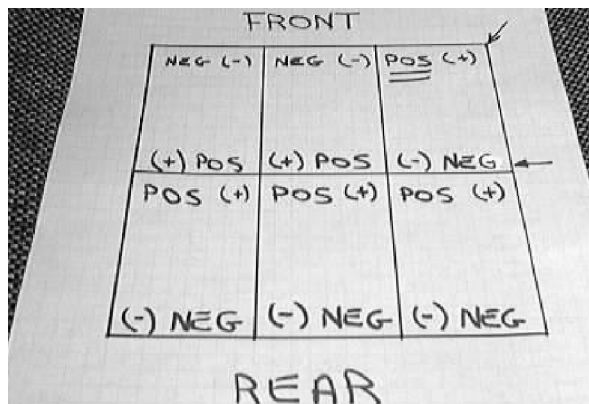

ELECTRICAL

8. Install the rear three batteries next.

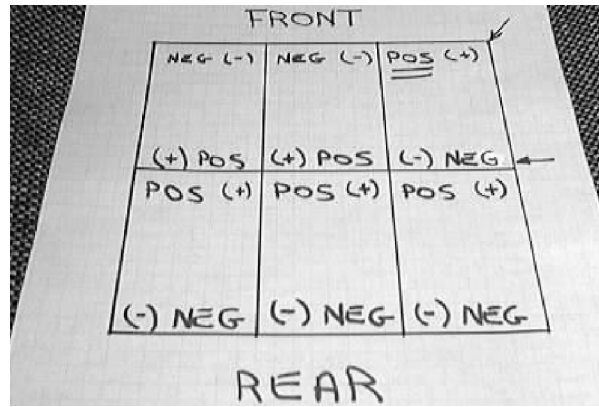

9. Reinstall the five small battery cables onto the new batteries.

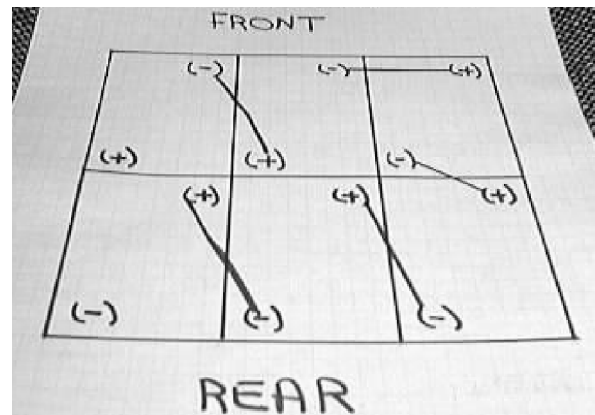

10. Reinstall the connector assembly onto the batteries.

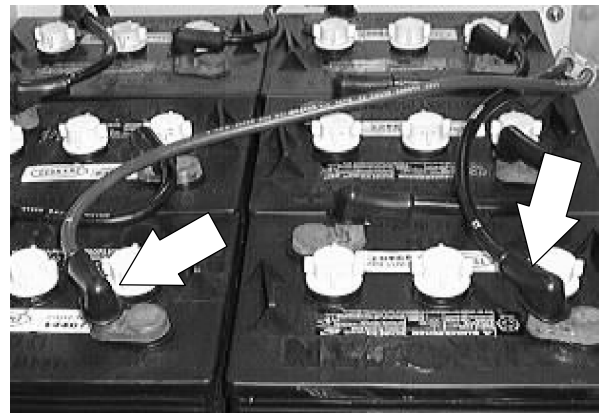

11. Reconnect the battery connect to the machine connector.

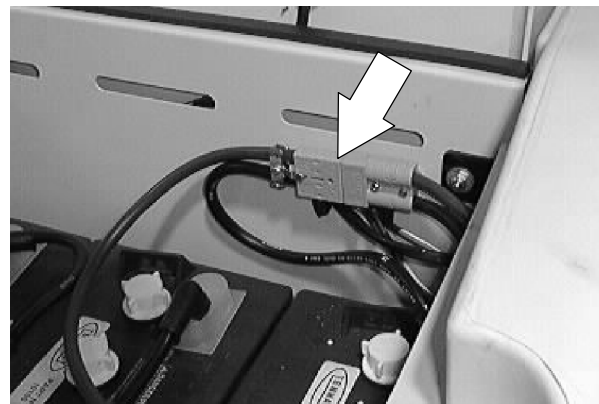

12. Disengage the prop rod and lower the seat support.



13. Start the machine and check the new batteries for proper operation.

INSTRUMENT PANEL

The instrument panel on the model 6100E contains the switches, gauges, and instruments needed to run the machine functions.



TO ACCESS INSTRUMENT PANEL

FOR SAFETY: Before Leaving Or Servicing Machine; Stop On Level Surface, Set Parking Brake.

1. Open the seat support and engage the prop rod.



2. Disconnect the machine batteries.

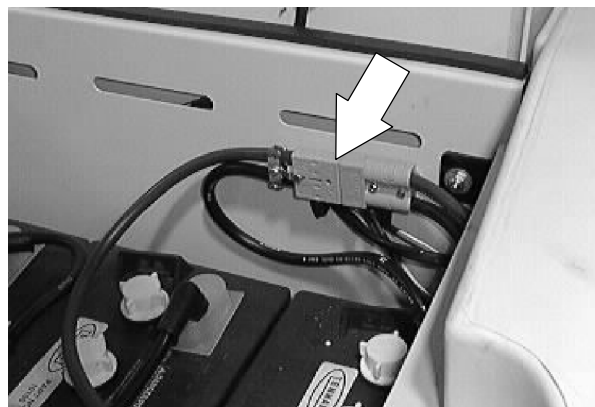

3. Disengage the prop rod and lower the seat support.



4. Tie the side brush in the up position.

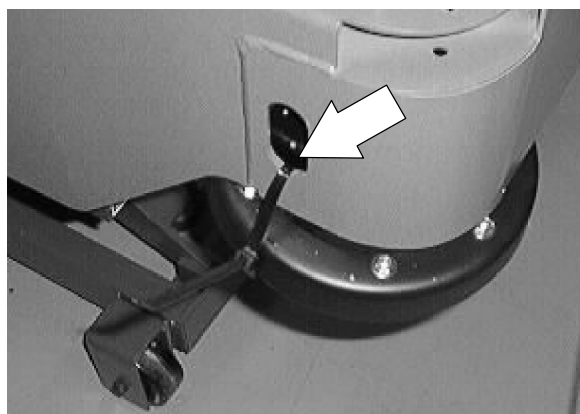

5. Remove the four hex screws and two pan screws holding the instrument panel to the front shroud.

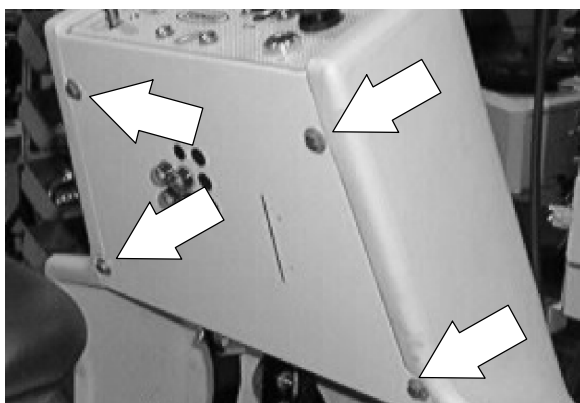

6. Pull the instrument panel back away from the front shroud for better access to the circuit breakers.

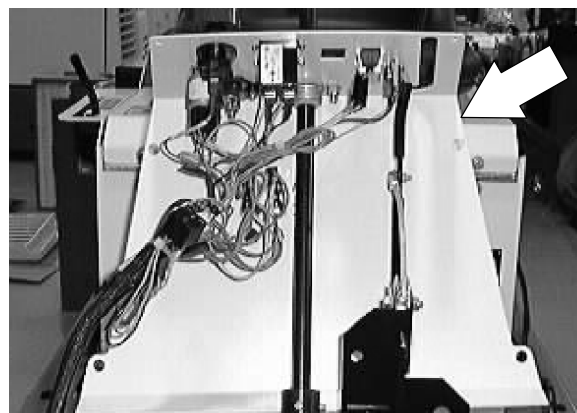

ELECTRICAL

7. Position the instrument panel back onto the front shroud. Reinstall the hardware and hand tighten tight.



8. Remove the tie holding the side brush in the up position.

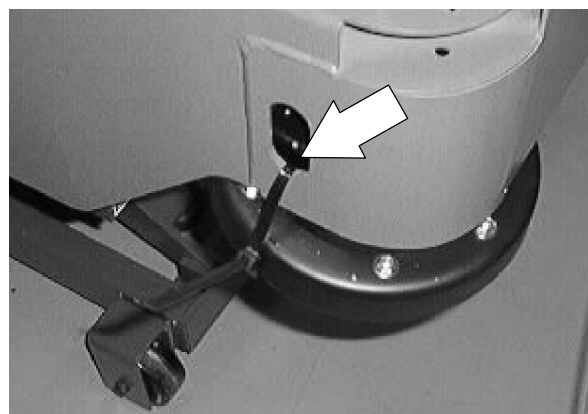

9. Open the seat support and engage the prop rod.



10. Reconnect the batteries.

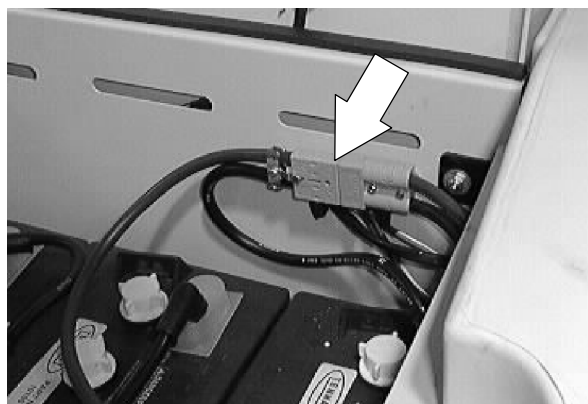

11. Disengage the prop rod and lower the seat support.

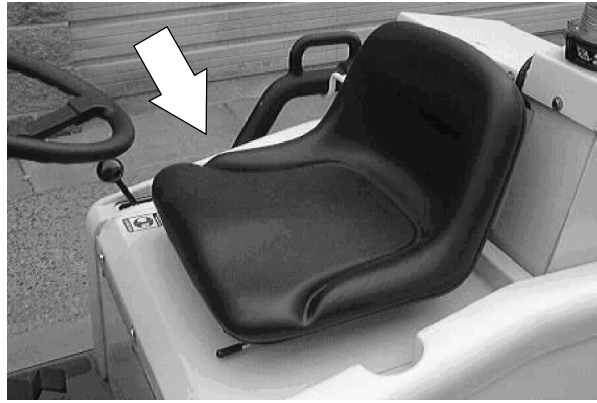

12. Start the machine and check for proper operation.



TO REPLACE INSTRUMENT PANEL CIRCUIT BREAKER

FOR SAFETY: Before Leaving Or Servicing Machine; Stop On Level Surface, Set Parking Brake.

1. Open the seat support and engage the prop rod.



2. Disconnect the machine batteries.

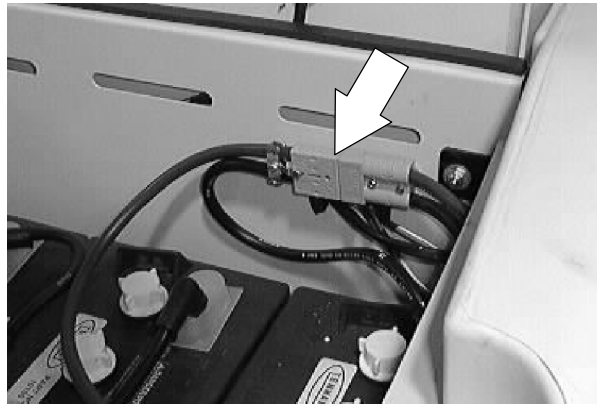

3. Disengage the prop rod and lower the seat support.



4. Tie the side brush in the up position.

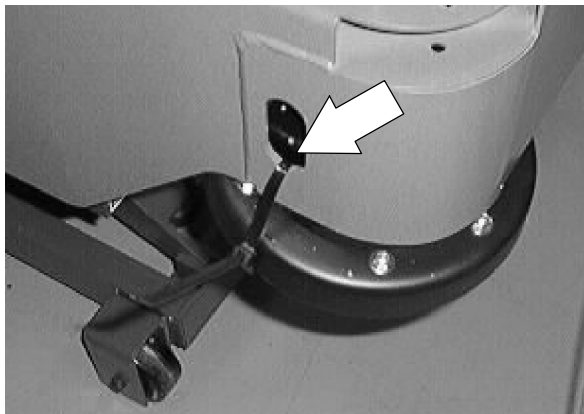

5. Remove the four hex screws and two pan screws holding the instrument panel to the front shroud.

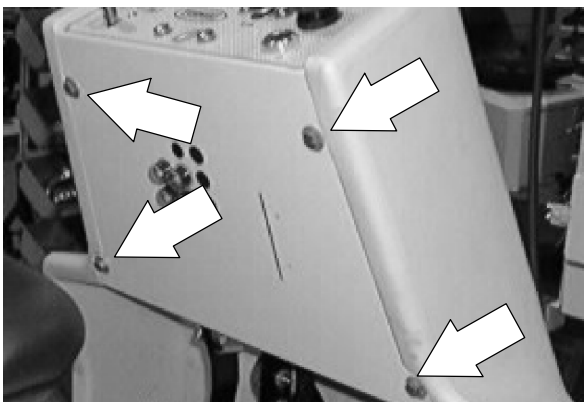

6. Pull the instrument panel back away from the front shroud for better access to the circuit breakers.

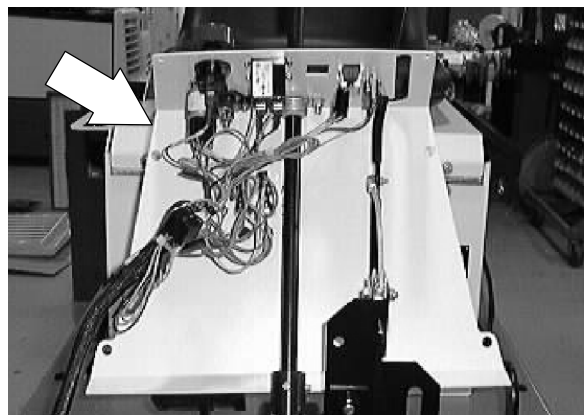

7. Locate the circuit breaker that needs to be changed.

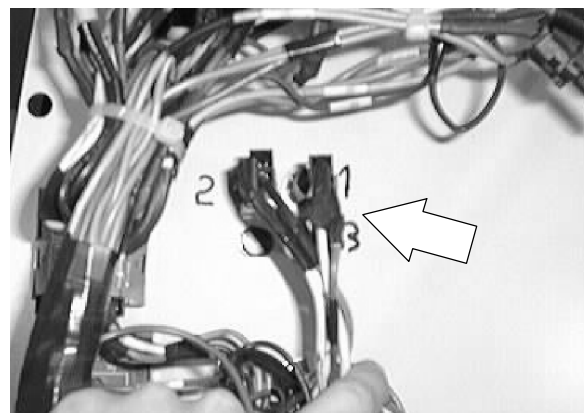

ELECTRICAL

8. Mark and disconnect the wires leading to the back of the circuit breaker.

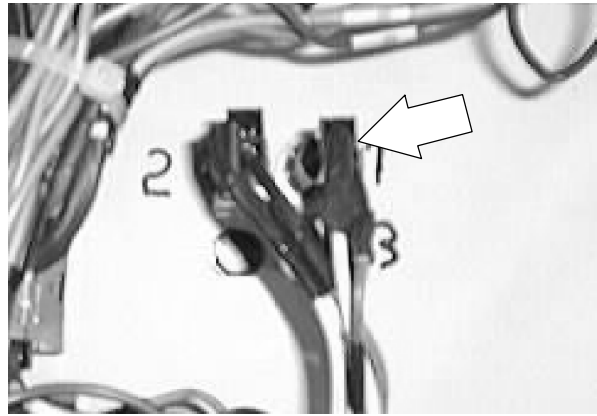

9. Remove the metal retainer ring from the back of the circuit breaker.
10. Push the circuit breaker out of the hole. Retain the clear, rubber boot and discard the circuit breaker.
11. Position the new circuit breaker into the mount hole. *NOTE: The mount hole has a "D" shape to match the shape of the circuit breaker.*

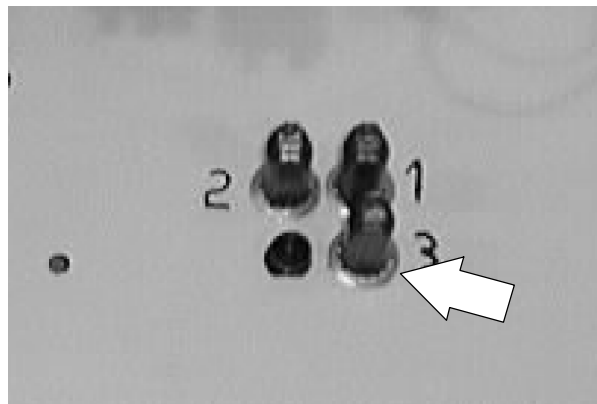

12. Install the metal retainer ring onto the back of the new circuit breaker. Push the retainer all the way down the circuit breaker.

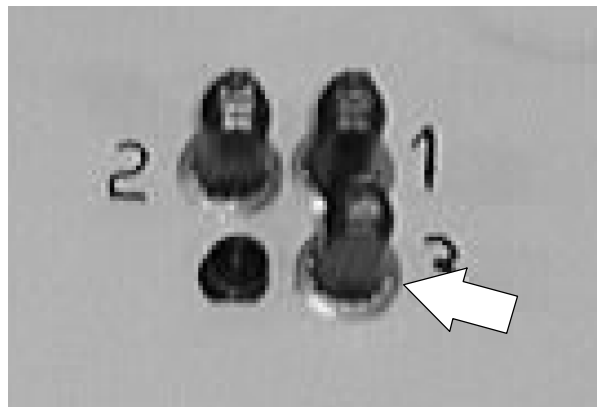

13. Install the rubber boot onto the outside of the new circuit breaker.

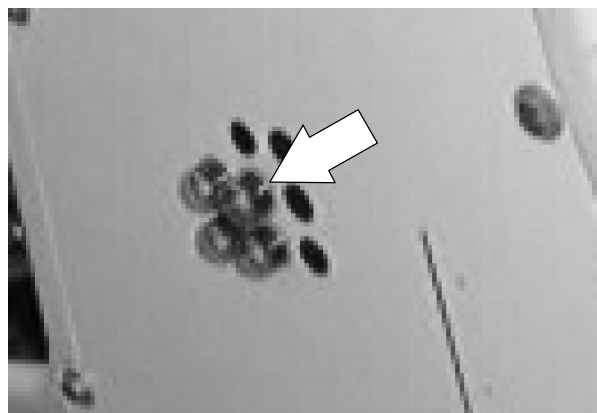

14. Reconnect the electrical wires to the new circuit breaker. See schematic in the ELECTRICAL section.

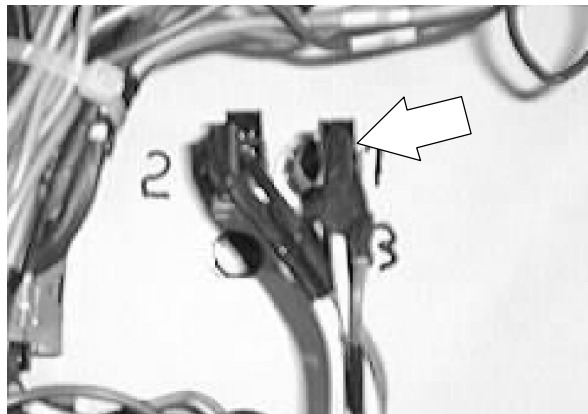

15. Position the instrument panel back onto the front shroud. Reinstall the hardware and hand tighten tight.



16. Remove the tie holding the side brush in the up position.

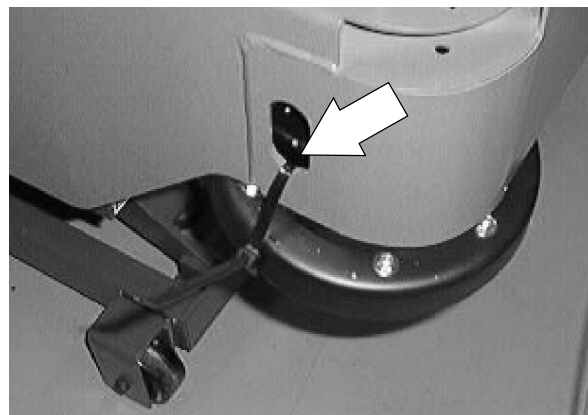

17. Open the seat support and engage the prop rod.



18. Reconnect the batteries.

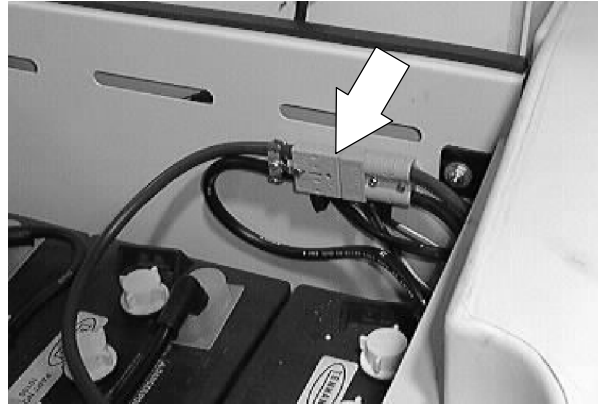

19. Disengage the prop rod and lower the seat support.



20. Start the machine and check for proper operation.



ELECTRICAL PANEL

The electrical panel on the model 6100E is located at the left, rear corner of the machine. The electrical panel contains the propel controller, relays, contactors, circuit breakers, and fuse.

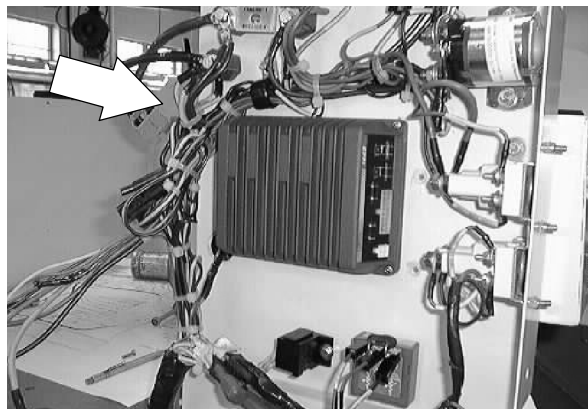
**TO ACCESS ELECTRICAL PANEL**

FOR SAFETY: Before Leaving Or Servicing Machine; Stop On Level Surface, Set Parking Brake.

1. Open the seat support and engage the prop rod.



2. Disconnect the machine batteries.

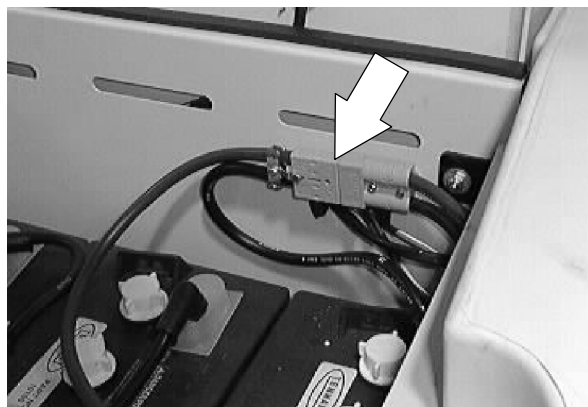

ELECTRICAL

3. Remove the left side machine panel by lifting up and back on the panel.



4. Make any repairs to the electrical components located on the electrical panel.

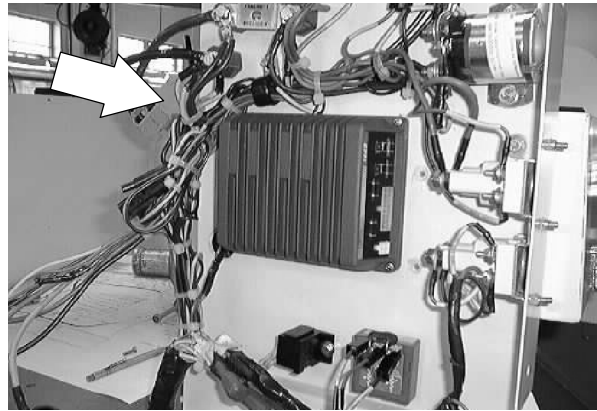

5. Reinstall the left side panel.



6. Reconnect the batteries.

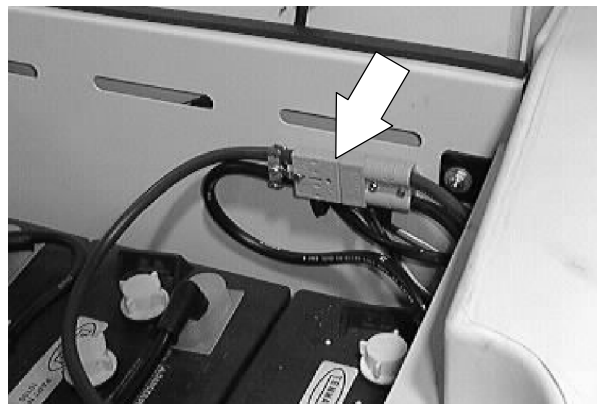

7. Disengage the prop rod and lower the seat support.



8. Start the machine and check for proper operation.



TO REPLACE PROPEL CONTROLLER

FOR SAFETY: Before Leaving Or Servicing Machine; Stop On Level Surface, Set Parking Brake.

1. Open the seat support and engage the prop rod.



2. Disconnect the machine batteries.

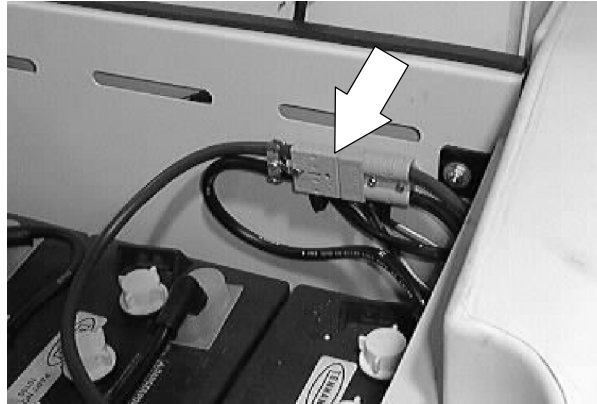

3. Remove the left side machine panel by lifting up and back on the panel.



4. Mark and disconnect the wires leading to the propel controller.

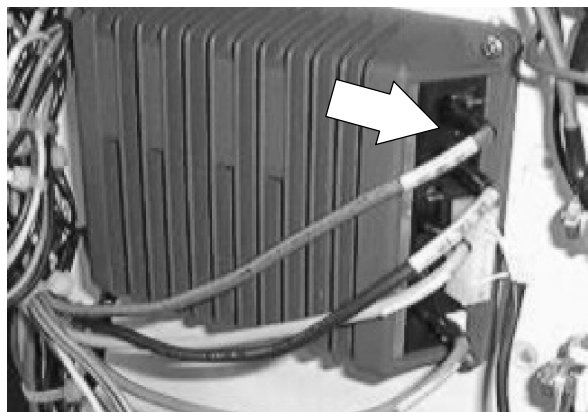

5. Remove the four screws and nuts holding the controller to the electrical panel. Remove the controller from the machine.

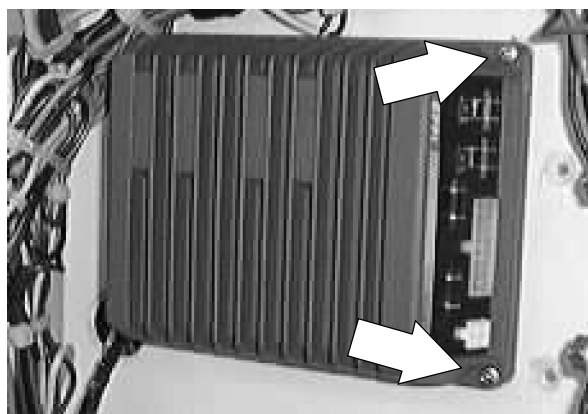

6. Install the new controller onto the electrical panel in the same orientation as the old one. Reinstall the hardware and hand tighten. *Do not over tighten.*



7. Reconnect the wires to the new controller. See schematic in this section.

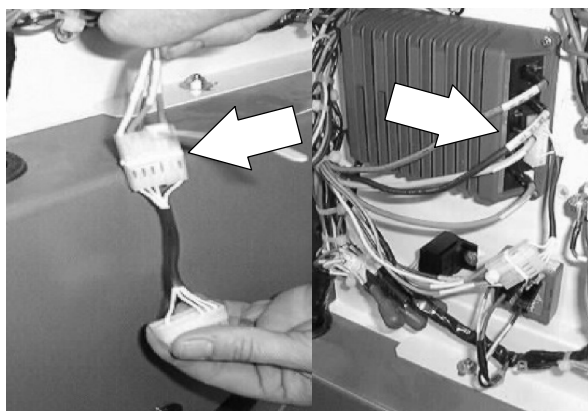

ELECTRICAL

8. Reinstall the left side panel.



9. Reconnect the batteries.

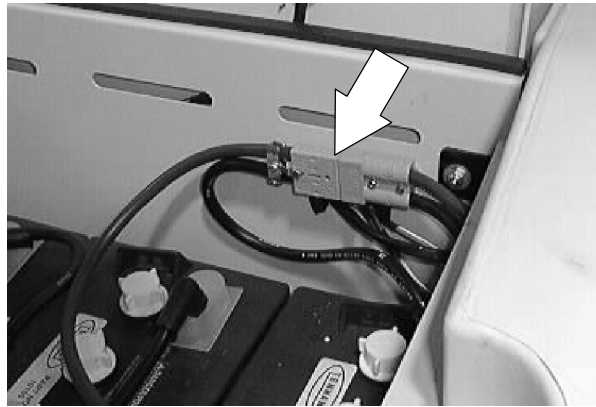

10. Disengage the prop rod and lower the seat support.



11. Start the machine and check for proper operation.



CIRCUIT BREAKERS

The circuit breakers are resettable electrical circuit protection devices. Their design stops the flow of current in the event of a circuit overload. Once a circuit breaker is tripped, it must be reset manually. Press the reset button after the breaker has cooled down. The circuit breakers will not reset until they have had a chance to cool down.

If the overload that caused the circuit breaker to trip is still there, the circuit breaker will continue to stop current flow until the problem is corrected.

Circuit breakers 1 through 6 are located above the foot pedals. Numbers 7 through 10 are located back under the left side panel.

The chart lists the circuit breakers and the electrical components they protect.

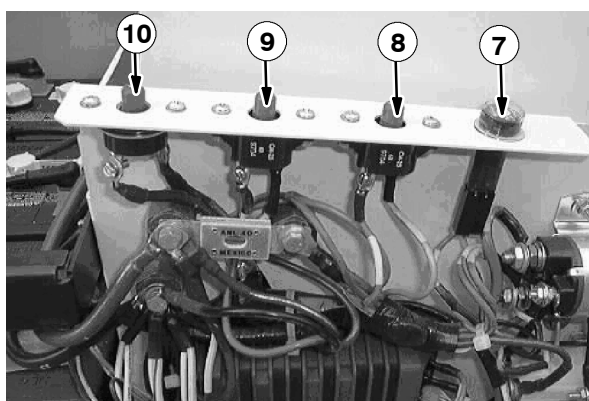
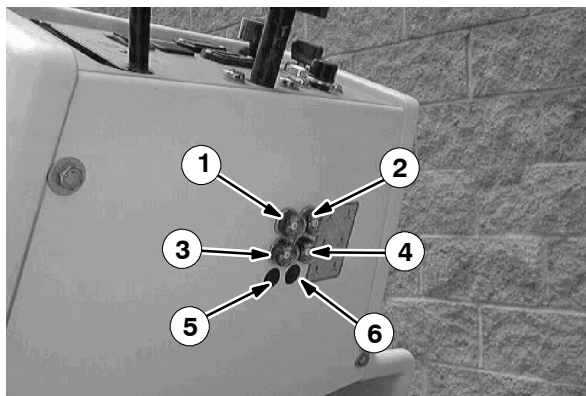

Circuit Breaker	Rating	Circuit Protected
CB-1	5 A	Main Power
CB-2	5 A	Main Power
CB-3	10 A	Sweeping
CB-4	10 A	Horn / Vac Wand
CB-5	15 A	Back Alarm / Lights
CB-6	15 A	Option
CB-7	10 A	Side Brush
CB-8	25 A	Main Brush
CB-9	25 A	Vac Fan Motor
CB-10	20 A	Vac Wand (Option)
CB-10	40 A	Dual Motor, Vac Wand (Option)

ELECTRICAL

TO REPLACE ELECTRICAL PANEL CIRCUIT BREAKER

FOR SAFETY: Before Leaving Or Servicing Machine; Stop On Level Surface, Set Parking Brake.

1. Open the seat support and engage the prop rod.



2. Disconnect the machine batteries.

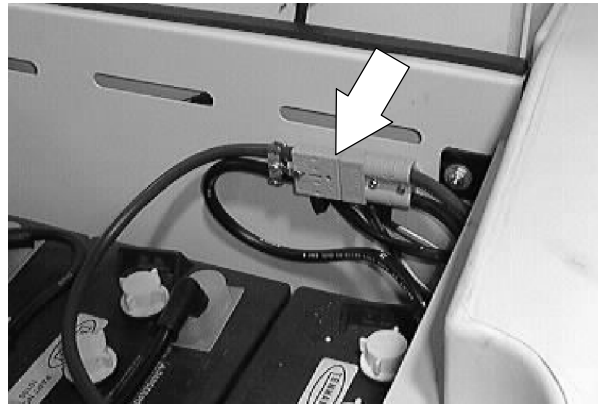

3. Remove the left side machine panel by lifting up and back on the panel.



4. Locate the circuit breaker that needs to be changed.

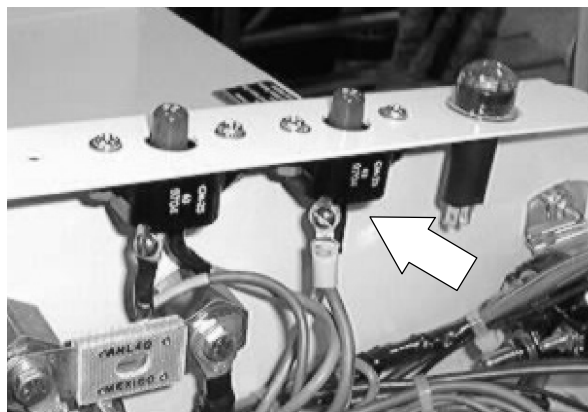

5. Remove the two pan screws holding the circuit breaker to the panel. Pull the circuit breaker out of the mount hole.

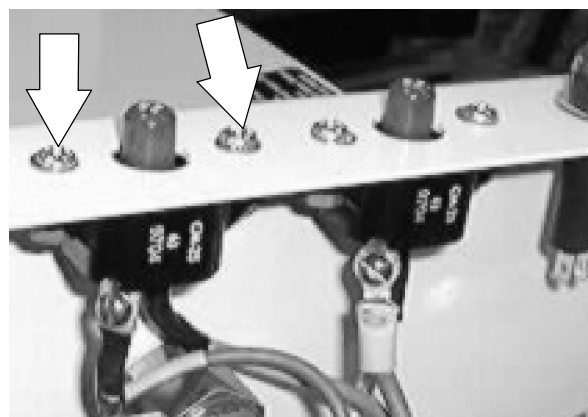

6. Mark and disconnect the wires leading to the bottom of the circuit breaker.

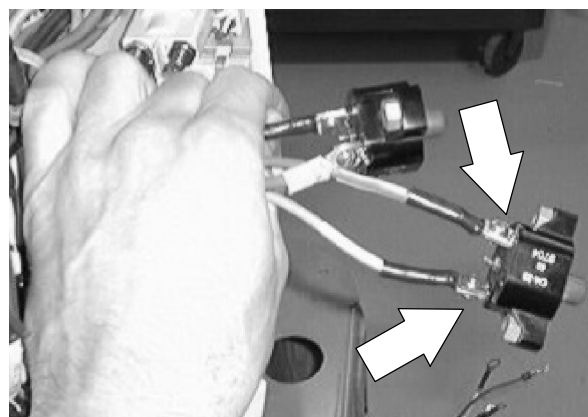

7. Connect the electrical wires to the new circuit breaker. See schematic in the ELECTRICAL section.

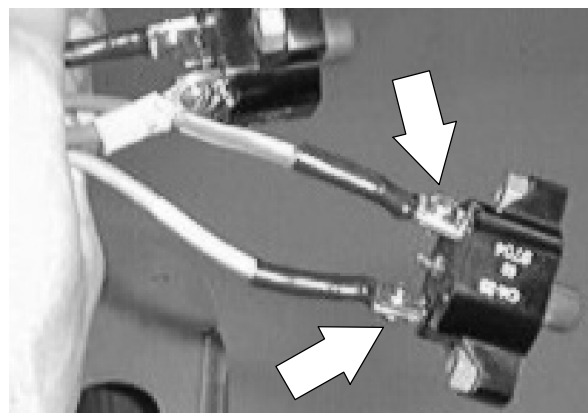

ELECTRICAL

8. Position the new circuit breaker into the mount hole. Reinstall the two pan screws and hand tighten tight.

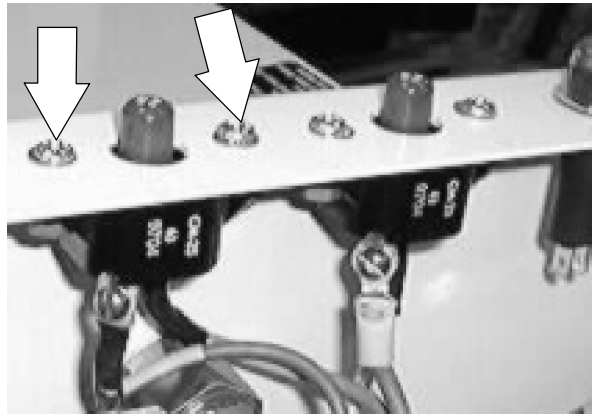

9. Reinstall the machine side panel.



10. Reconnect the batteries.

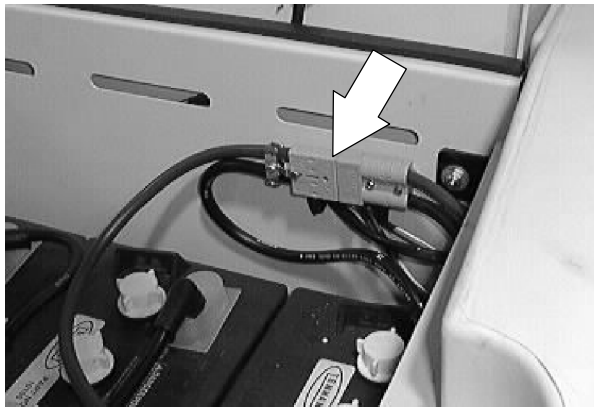

11. Disengage the prop rod and lower the seat support.



12. Start the machine and check for proper operation.

FUSES

Fuses are one-time protection devices designed to stop the flow of current in the event of a circuit overload. Never substitute higher value fuses than specified.

The fuse is located in the control box.

Fuse	Rating	Circuit Protected
FU-1	40 A	Main

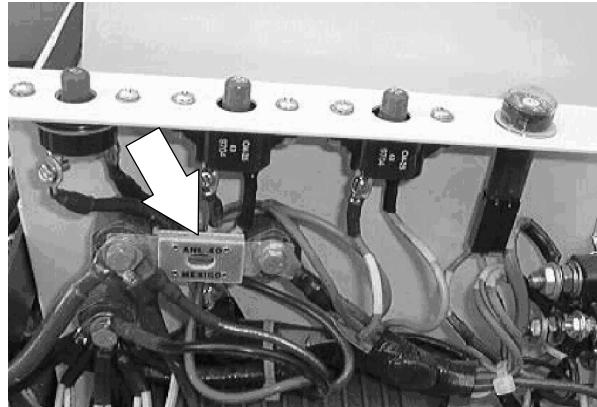

TO REPLACE ELECTRICAL PANEL 40 AMP FUSE

FOR SAFETY: Before Leaving Or Servicing Machine; Stop On Level Surface, Set Parking Brake.

1. Open the seat support and engage the prop rod.



2. Disconnect the machine batteries.

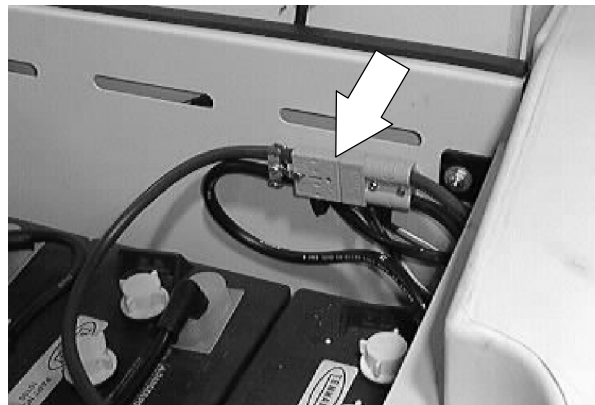

ELECTRICAL

3. Remove the left side machine panel.



4. Locate the 40 amp fuse at the front, upper area of the electrical panel.

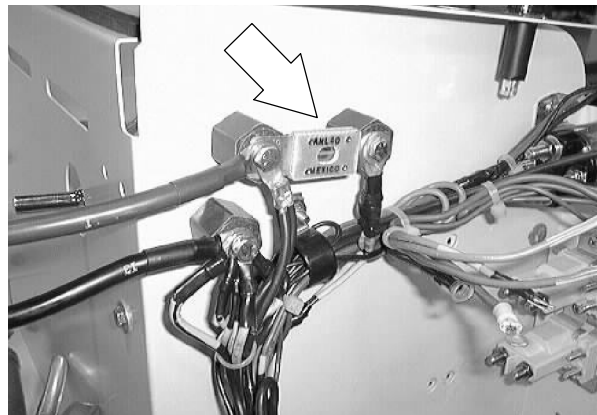

5. Loosen the two hex screws holding the fuse to the insulator stand offs.

6. Pivot one end of the fuse up and off the hex screw, then slip the other end of the fuse from under the other hex screw. Remove and discard the fuse.

7. Install the new fuse under the two hex screws. Hand tighten the hex screws tight.



8. Reinstall the machine side panel.



9. Reconnect the batteries.

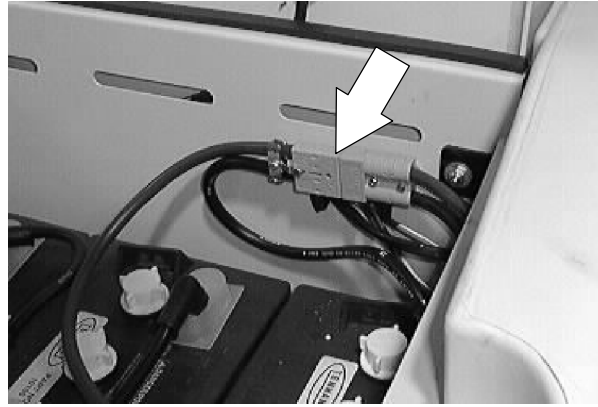

10. Disengage the prop rod and lower the seat support.



11. Start the machine and check for proper operation.



DIRECTIONAL PEDAL

The directional pedal controls the direction of travel and the propelling speed of the machine. Change the speed of the machine with the pressure of your foot on the pedal; the harder you press the faster the machine travels.

Use the brake pedal to stop the machine.

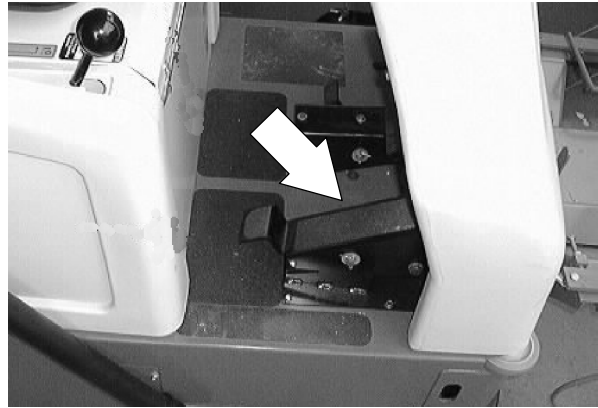

TO REMOVE DIRECTIONAL PEDAL ASSEMBLY

FOR SAFETY: Before Leaving Or Servicing Machine; Stop On Level Surface, Set Parking Brake.

1. Open the seat support and engage the prop rod.



2. Disconnect the machine batteries.

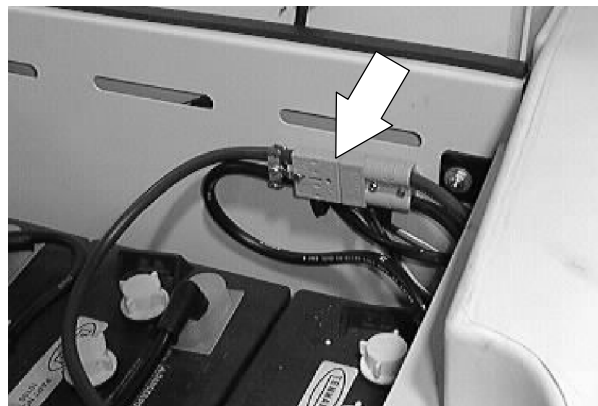

3. Lower the side brush.

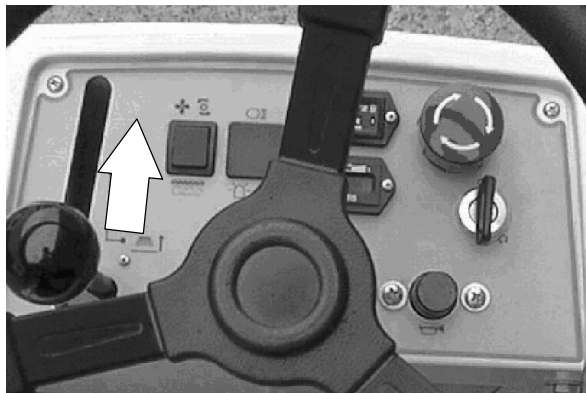

4. Go under the machine in the area of the right hand side brush. Locate the wires and connector leading from the directional pedal.



5. Disconnect the directional pedal connector from the main harness. Remove any plastic ties holding the directional pedal harness to the main harness.

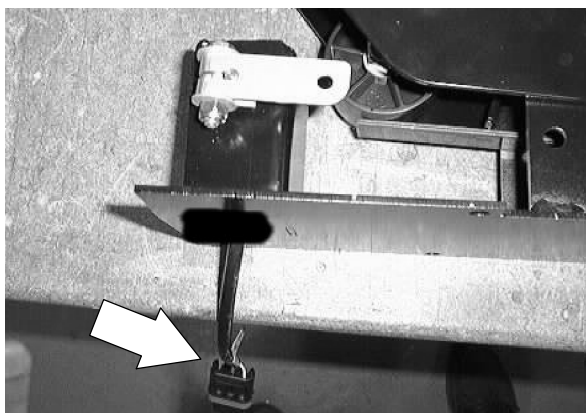

6. Go to the operator's compartment and locate the directional pedal assembly. Remove the four thread rolling screws holding the directional pedal to the floor plate.

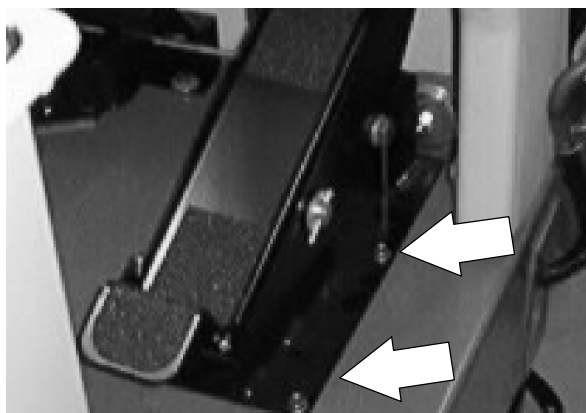

7. Remove the pedal assembly from the machine.

TO INSTALL DIRECTIONAL PEDAL ASSEMBLY

FOR SAFETY: Before Leaving Or Servicing Machine; Stop On Level Surface, Set Parking Brake.

1. Position the directional pedal assembly in the machines operators compartment.

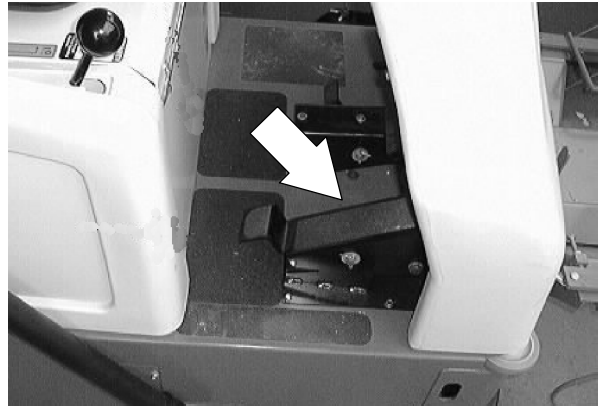

2. Feed the pedal harness down through the access hole in the floor plate.

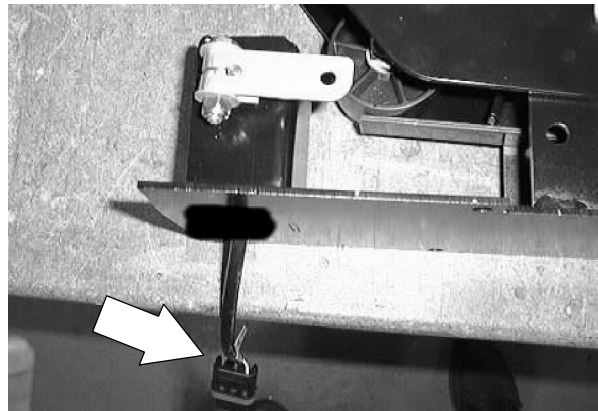

3. Line up the mount holes in the pedal assembly plate with the mount holes in the machines floor plate.

4. Reinstall the four thread rolling screws and tighten to 8 - 10 Nm (6 - 7 ft lb).

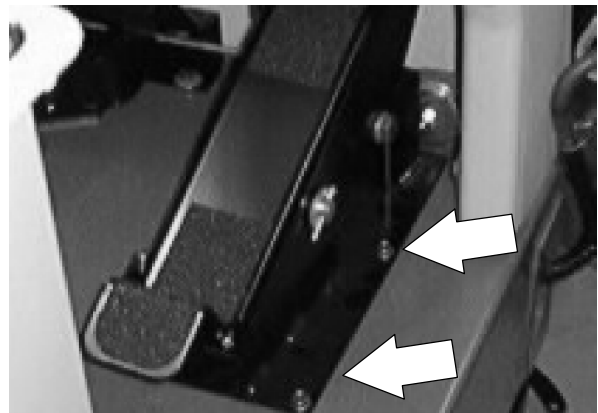

5. Go under the machine in the area of the right hand side brush. Locate the wires and connector leading from the directional pedal.
6. Reconnect the directional pedal connector to the main harness. Reinstall any plastic ties that were holding the directional pedal harness to the main harness.

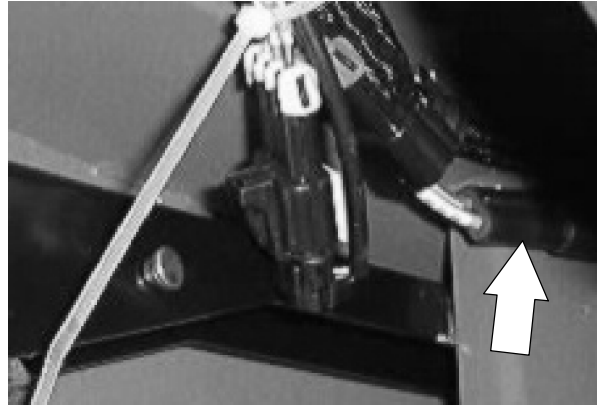

7. Reconnect the batteries.

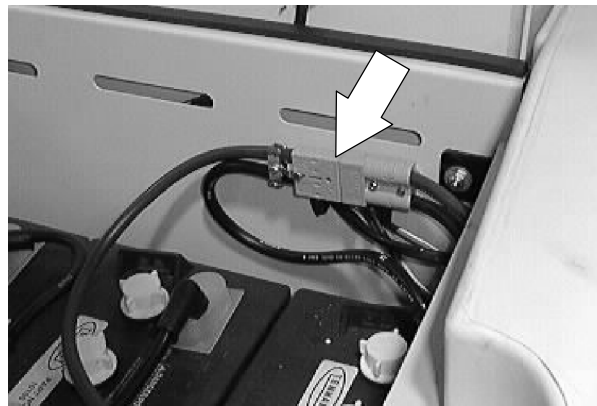

8. Disengage the prop rod and lower the seat support.



9. Start the machine and check for proper operation. Set the pedal neutral if needed. See TO SET POTENTIOMETER NEUTRAL instructions in this section.



TO REPLACE DIRECTIONAL PEDAL POTENTIOMETER

FOR SAFETY: Before Leaving Or Servicing Machine; Stop On Level Surface, Set Parking Brake.

1. Remove the directional pedal assembly from the machine. See TO REMOVE DIRECTIONAL PEDAL ASSEMBLY instructions in this section.

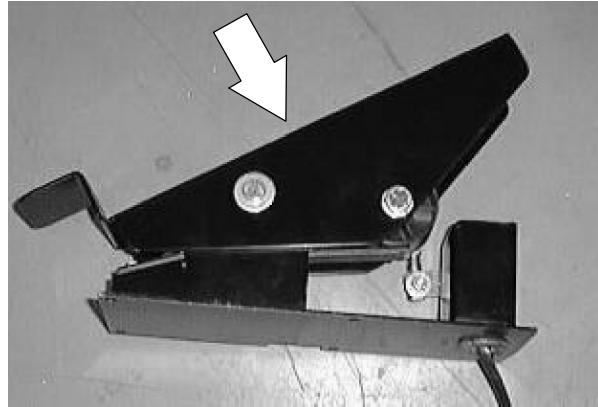

2. Loosen the hex screw and nut holding the accelerator lever to the potentiometer. Remove the accelerator lever from the potentiometer shaft.

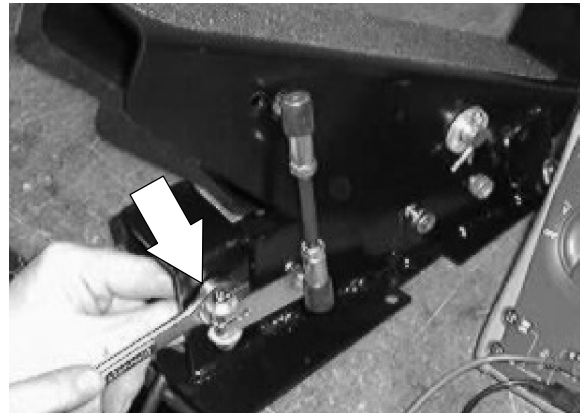

3. Remove the thin hex nut from the potentiometer shaft.

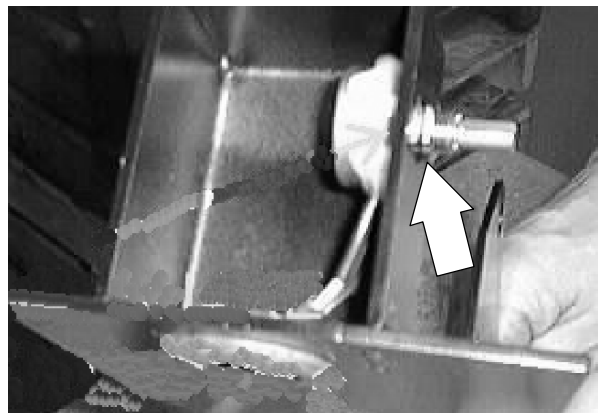

- Note the orientation of the existing potentiometer and remove it from the pedal assembly.
- Install the new potentiometer onto the pedal assembly in the same orientation as the old one. Reinstall the thin hex nut and **tighten lightly**.



- With the directional pedal in the neutral position, reinstall the accelerator lever onto the shaft of the potentiometer. Hand tighten the hex screw and nut.

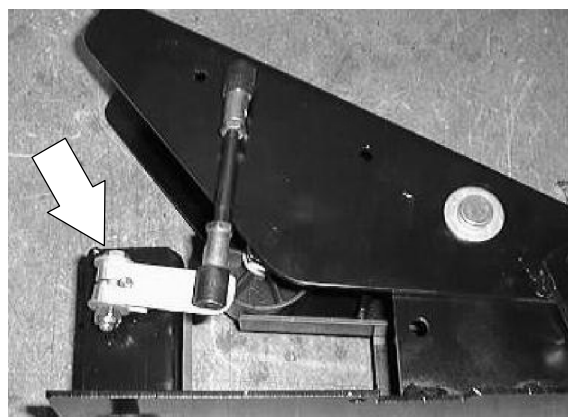

- Check the length of the threaded rod/ball joint assembly. Measure the distance between the ball joint centers. The dimension should be approximately 4 inches. If an adjustment needs to be made, loosen the upper jam nut and turn the rod. Re-tighten the jam nut.

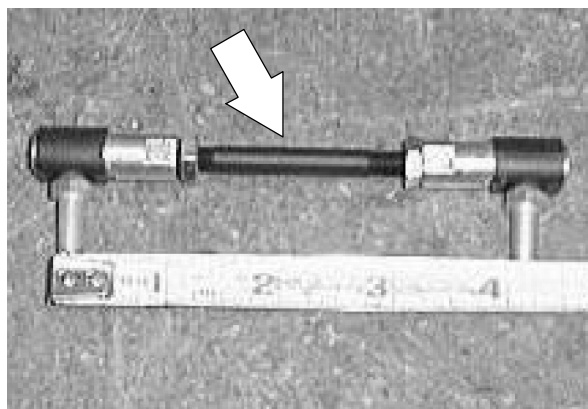

- Reinstall the directional pedal assembly into the machine. See TO INSTALL DIRECTIONAL PEDAL ASSEMBLY instructions in this section.

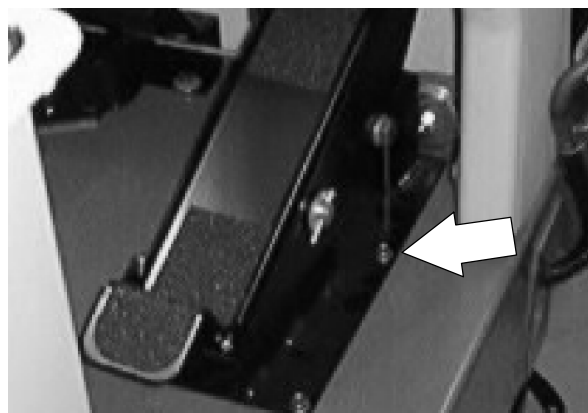

ELECTRICAL

9. Check the new potentiometer for neutral.
See TO SET POTENTIOMETER NEUTRAL instructions in this section.

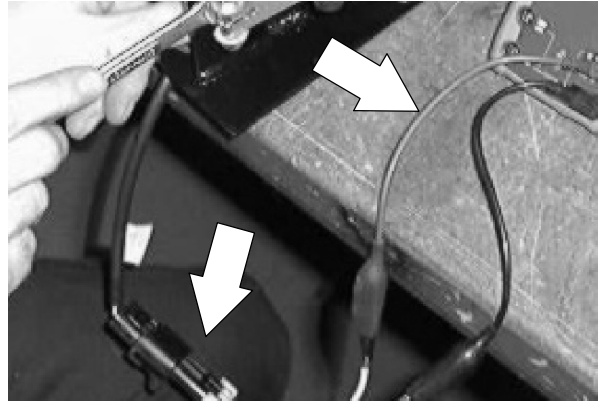

10. Operate the machine. Check the new potentiometer for proper operation.



TO SET POTENTIOMETER NEUTRAL

FOR SAFETY: Before Leaving Or Servicing Machine; Stop On Level Surface, Set Parking Brake.

1. Open the seat support and engage the prop rod.



2. Disconnect the machine batteries.

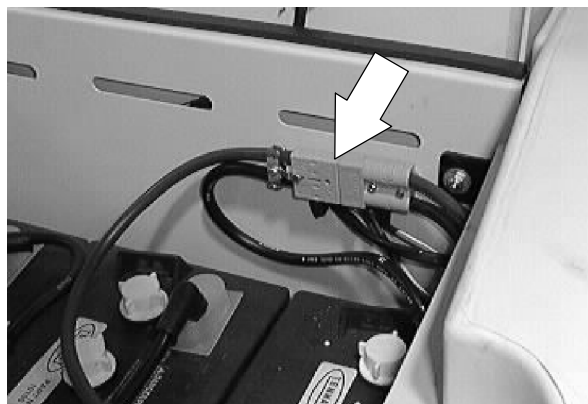

3. Lower the side brush.

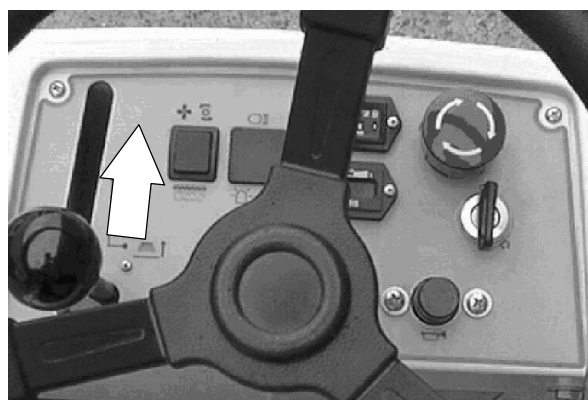

ELECTRICAL

4. Go under the machine in the area of the right hand side brush. Locate the wires and connector leading from the directional pedal.

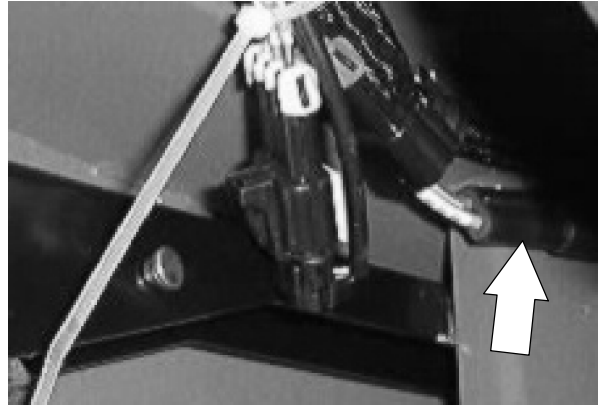

5. Disconnect the directional pedal connector from the main harness. Remove any plastic ties holding the directional pedal harness to the main harness.



6. Use a multimeter, set to the OHMS setting. Check the red (B) and white (A) of the connector with the meter.

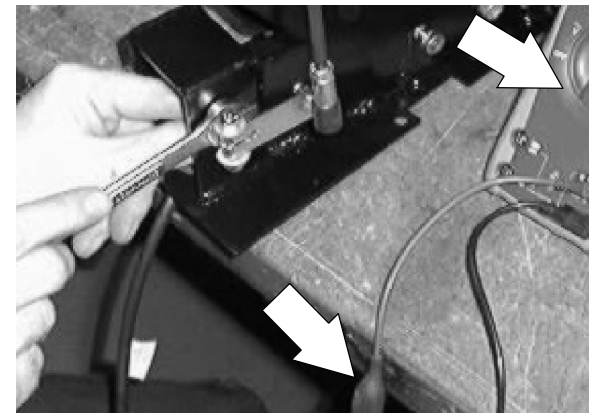

7. The meter reading should be 2500 OHMS (\pm 50 OHMS).

8. Loosen the upper jam nut on the threaded rod. Turn the rod to achieve the proper OHM reading. Tighten the jam nut.

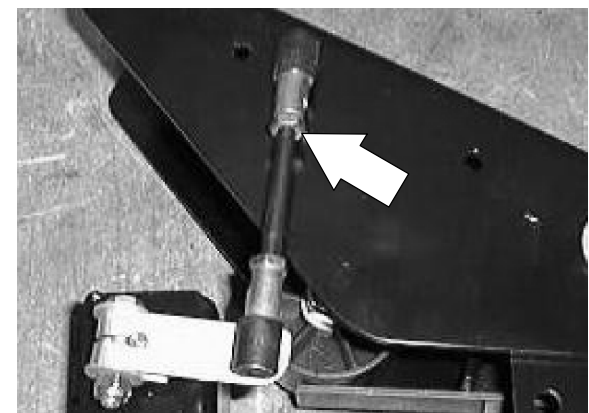

9. Reconnect the batteries.

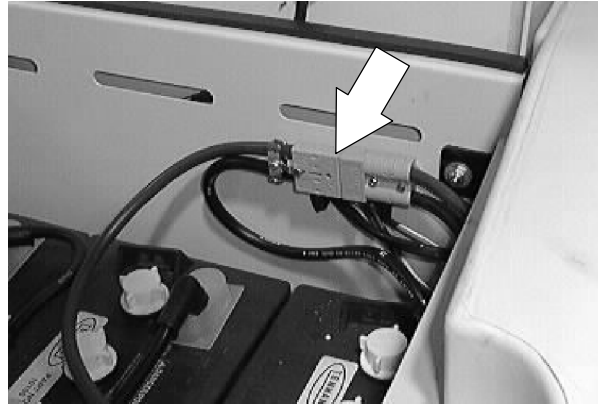

10. Disengage the prop rod and lower the seat support.



11. Operate the machine. Check the machine for proper neutral operation.



ELECTRIC MOTORS

The carbon brushes on the propelling and accessories motors should be inspected after every 800 hours of machine operation.



TO REPLACE FRONT DRIVE WHEEL MOTOR

FOR SAFETY: Before Leaving Or Servicing Machine; Stop On Level Surface, Set Parking Brake.

1. Jack up the front of the machine at the jack point. Install jack stands under the machine frame.

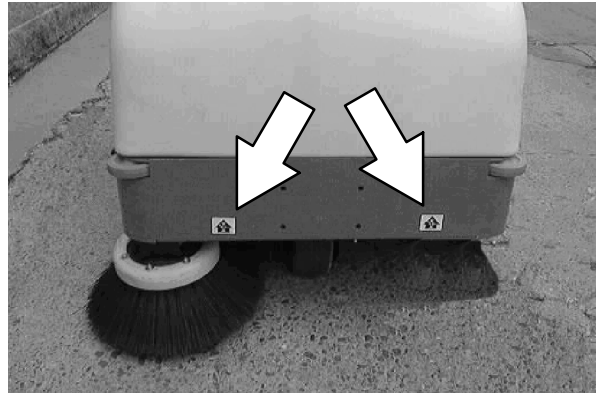

2. Open the seat support and engage the prop rod.



3. Disconnect the machine batteries.

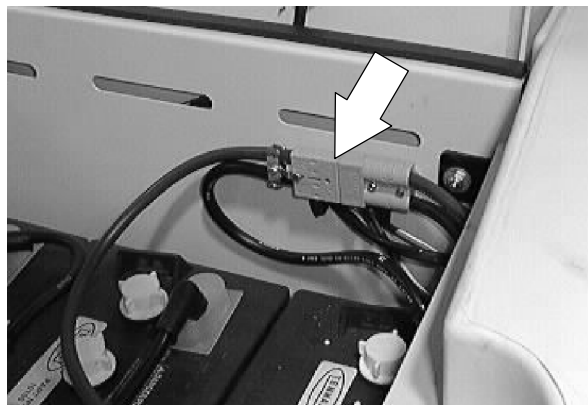

4. Remove the two nuts holding the chain guard to the wheel support. Remove the chain guard.

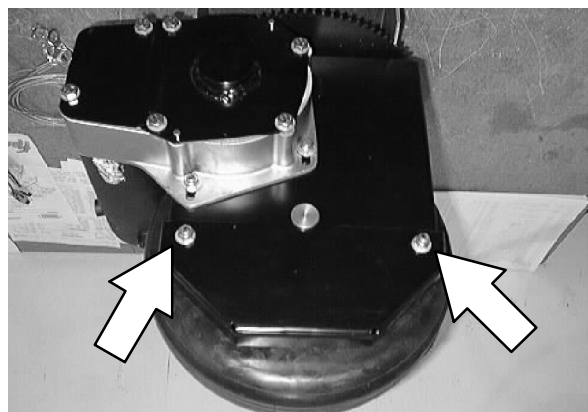

5. Loosen the three nuts holding the gearbox assembly to the wheel support. Let the gearbox drop down so the drive chain has some slack.

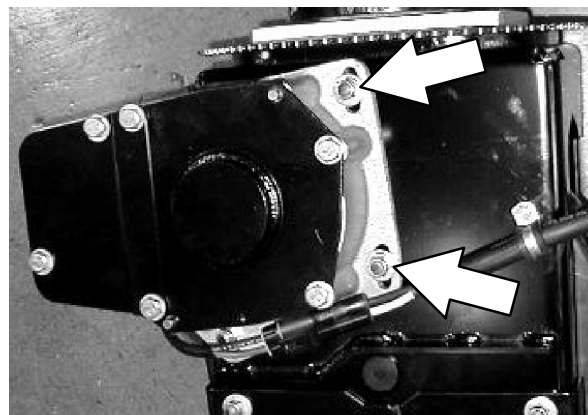

6. Turn the front tire until the master link is visible at the bottom of the drive sprocket. Remove the master link from the drive chain. **Make sure to retain the four small O-rings from behind the master link clip.**

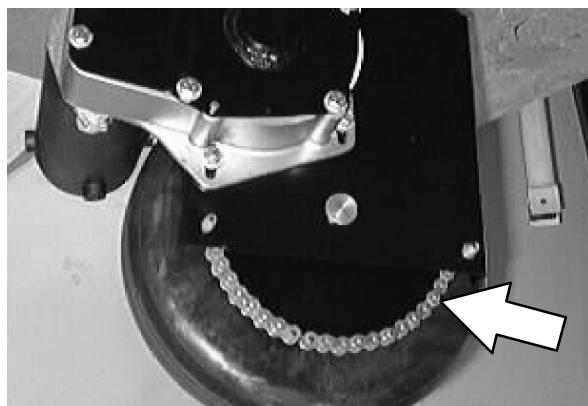

ELECTRICAL

7. Pull the chain off the drive motor sprocket and drive wheel sprocket. Remove the drive chain from the machine.

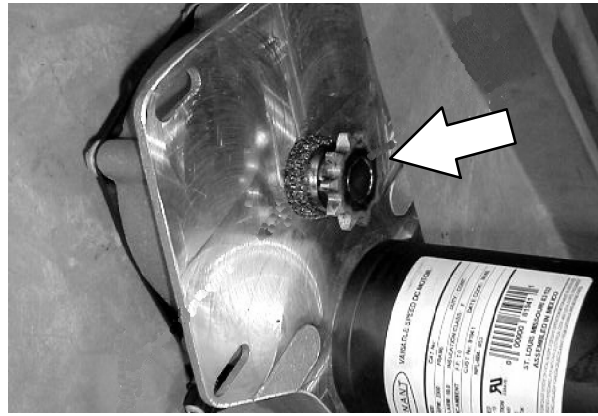

8. Disconnect the drive motor from the main electrical harness.

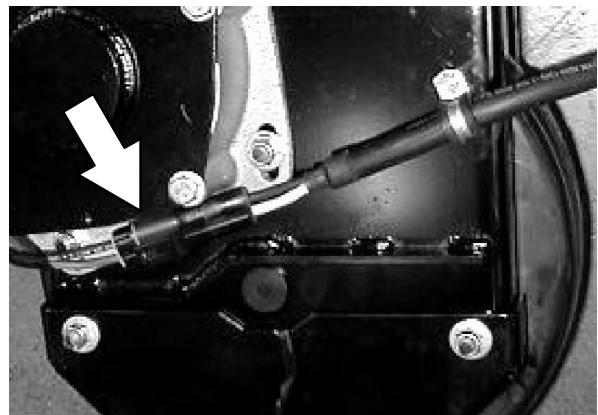

9. Finish removing the three nuts and washers holding the gearbox assembly to the wheel support. Remove the gearbox assembly from the machine.

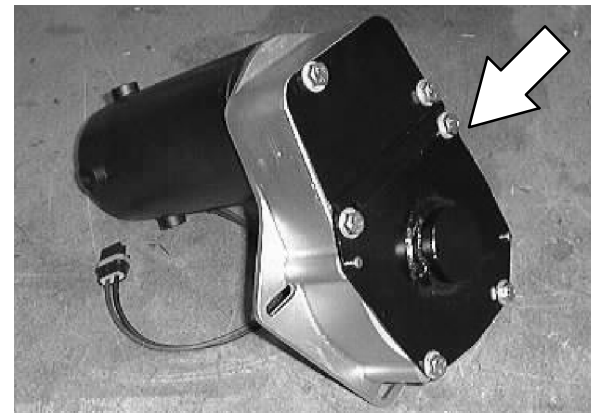

10. Remove the four hex screws holding the smaller black cover to the side of the gearbox.

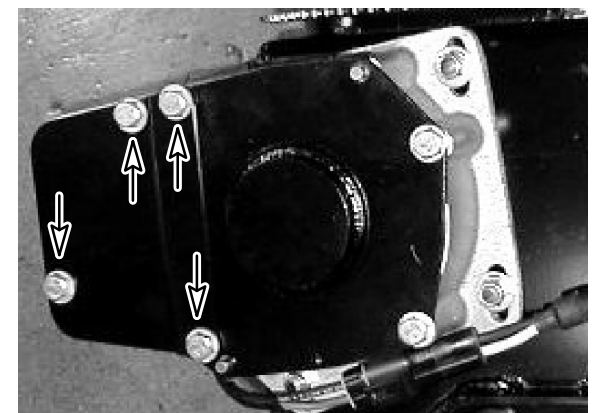

11. Remove the smaller black cover from the gearbox.

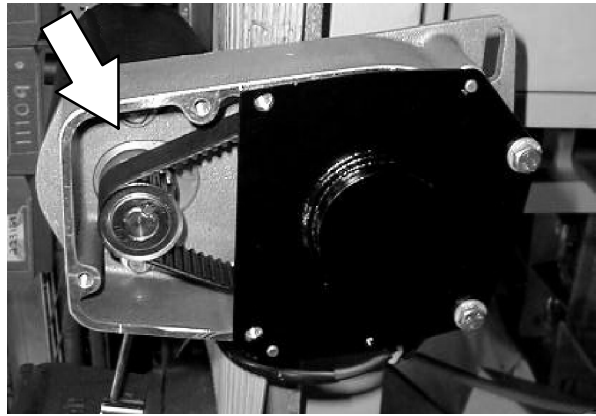

12. Loosen the two hex screws holding the electric drive motor to the back side of the gearbox assembly. Slide the motor and remove the cogged belt from the sprocket.

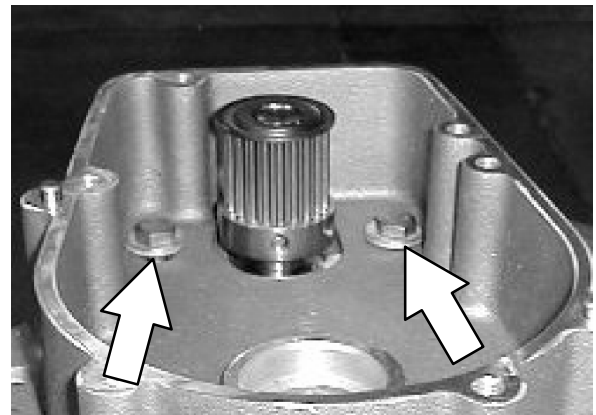

13. Remove the two hex screws from the drive motor. Remove the motor from the gearbox. *Make sure to note the orientation of the drive motor electric wires in relation to the gearbox.*

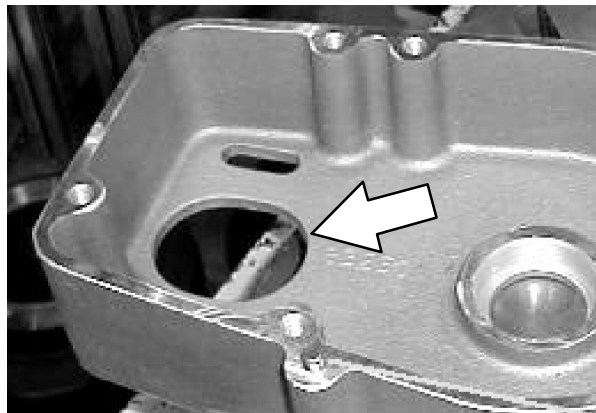

14. Loosen the set screws holding the small timing sprocket to the drive motor. Slide the sprocket off the shaft. *Make sure to retain the square key.*



ELECTRICAL

15. Install the new electric drive motor onto the gearbox. *Make sure to orientate the electric wires from the drive motor properly.*
16. Reinstall the two hex screws and washers into the drive motor.

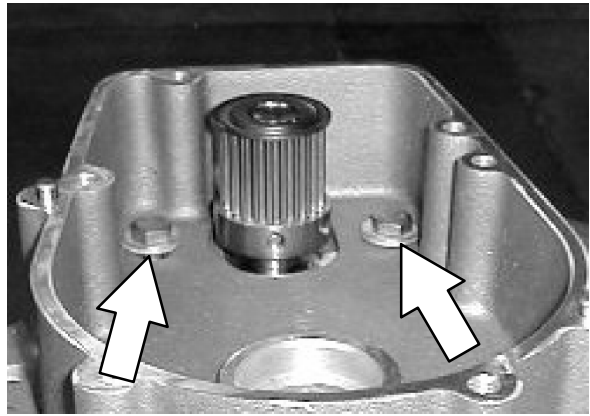

17. Reinstall the small cogged sprocket on the new motor. Locate the small sprocket flush with the end on the motor shaft.

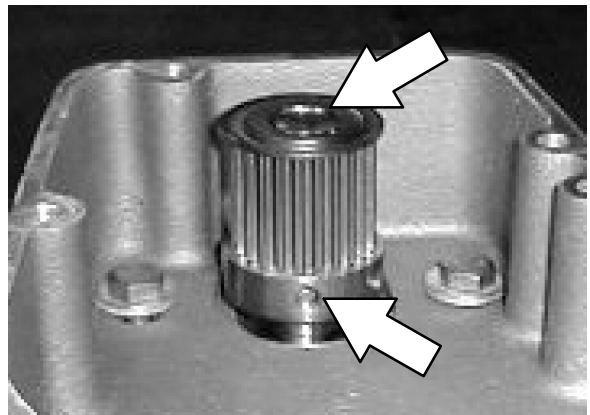

18. Position the cogged belt onto the small sprocket.

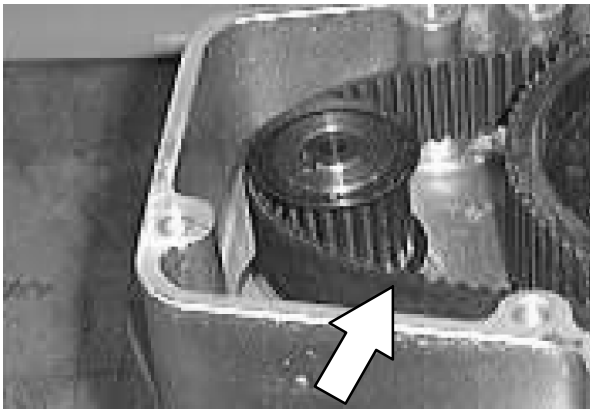

19. Use a large channel lock pliers to pull the drive motor to the front of the gearbox. Place one side of the pliers over the small pulley and the other side of the pliers on the front side of the gearbox. Squeeze the pliers until the belt is tight (*1/16 inch play at midpoint*). Tighten the two motor mount screws to 18 - 24 Nm (15 - 20 ft lb).

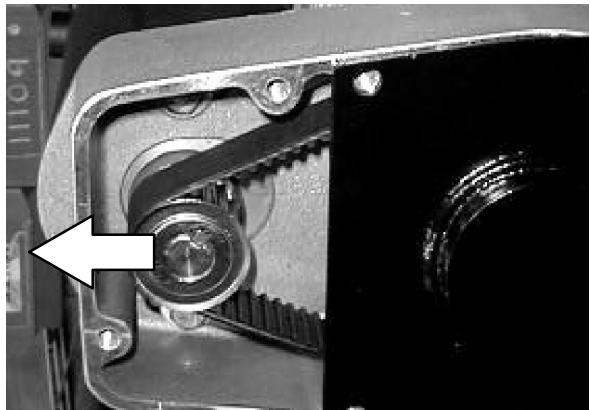

20. Install the belt cover onto the gearbox. Install the four hex screws and tighten to 18 - 24 Nm (15 - 20 ft lb).

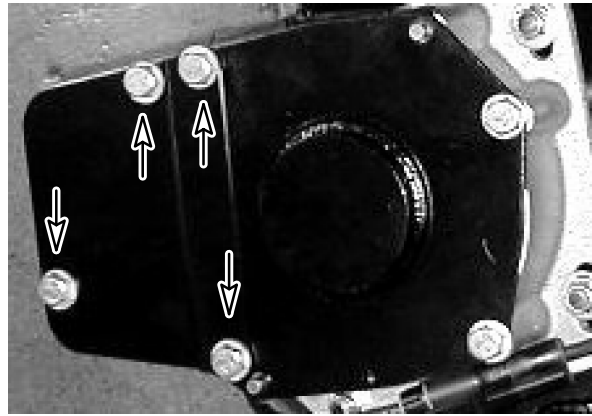

21. Position the gearbox assembly onto the wheel support. *The three slots on the gearbox go over the three studs on the wheel support.*

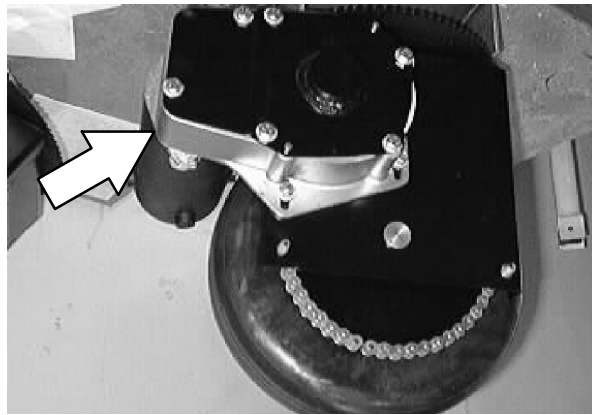

22. Install the three washers and nuts onto the wheel housing studs. Leave loose for now.

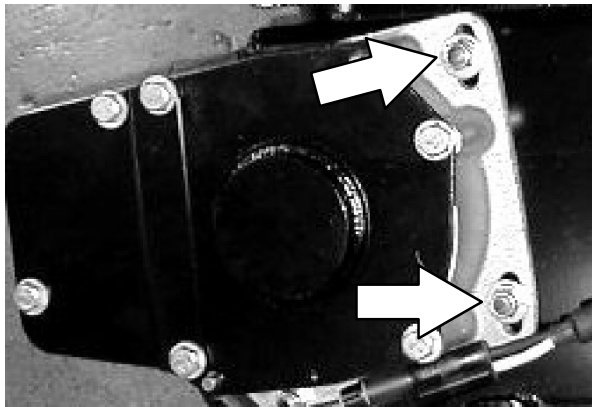

23. Reinstall the drive chain around the drive sprocket on the drive motor and front wheel assembly. Reinstall the master link. **Make sure the four small O-rings are in place behind the master link clip.**



ELECTRICAL

24. Push the gearbox assembly up until the chain is tight ($\pm 1/8$ inch at mid-point). Tighten nuts to 18 - 24 Nm (15 - 20 ft lb).

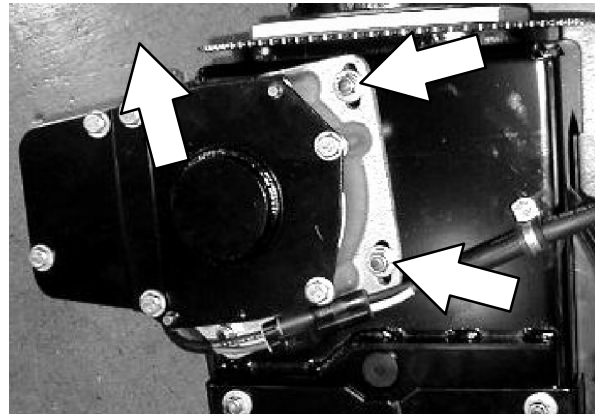

25. Reinstall the drive chain guard and tighten the two nuts to 18 - 24 Nm (15 - 20 ft lb).

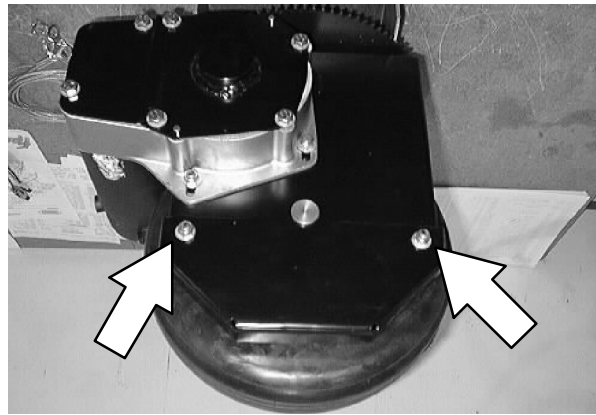

26. Reconnect the drive motor to the main electrical harness.

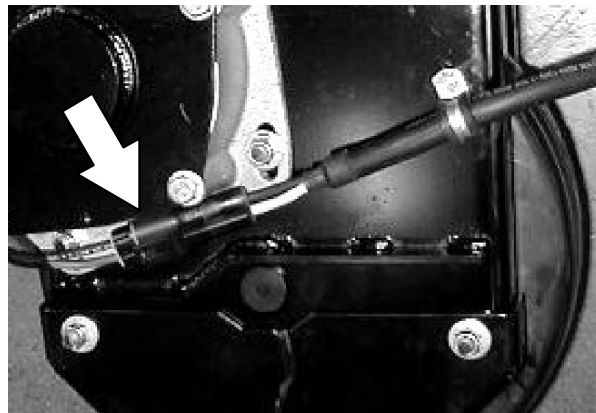

27. Remove the jack stands and lower the machine to the floor. Operate the machine and check the gearbox assembly for proper operation.

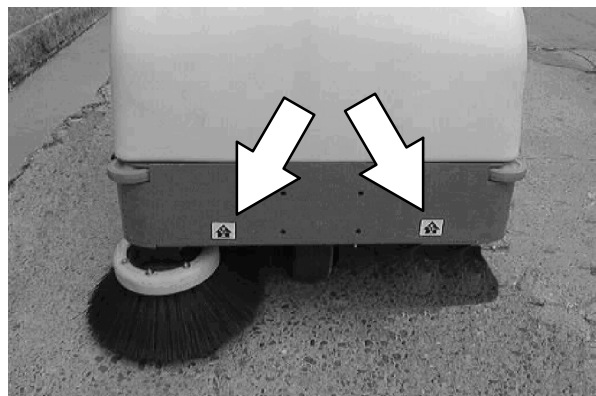

28. Reconnect the batteries.

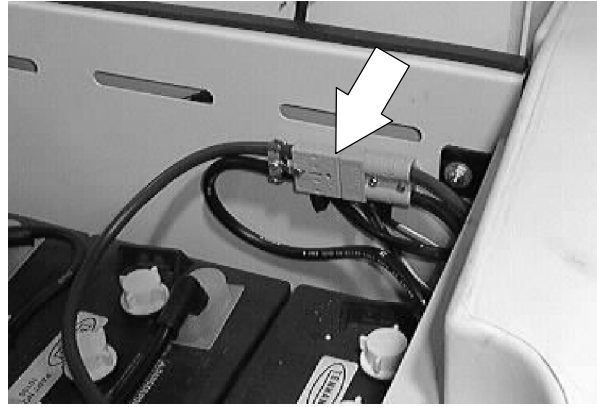

29. Disengage the prop rod and lower the seat support.



30. Operate the machine. Check the machine for proper operation.



TO REPLACE MAIN BRUSH MOTOR

FOR SAFETY: Before Leaving Or Servicing Machine; Stop On Level Surface, Set Parking Brake.

1. Jack up the front of the machine at the jack point. Install jack stands under the machine frame.

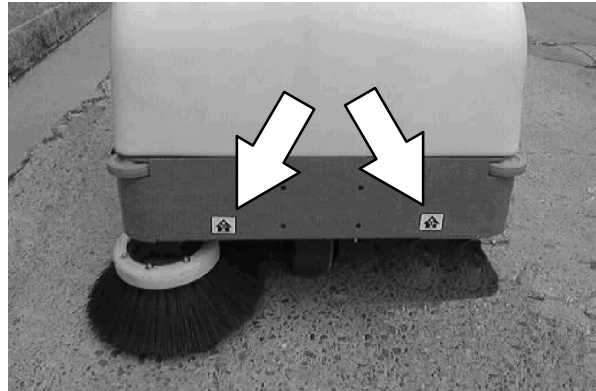

2. Lower the main brush lever.



3. Open the seat support and engage the prop rod.



4. Disconnect the machine batteries.

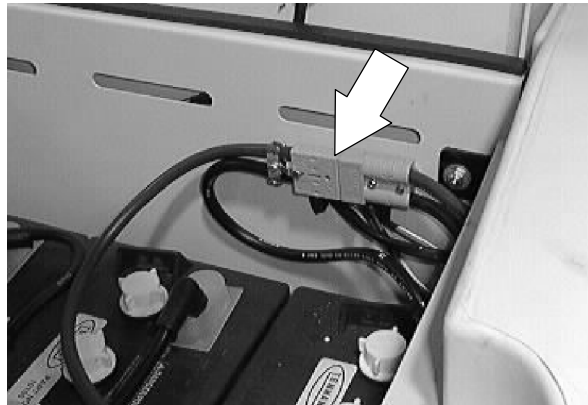

5. Remove the four screws holding the right hand brush door to the machine frame. Remove the right hand side brush door.

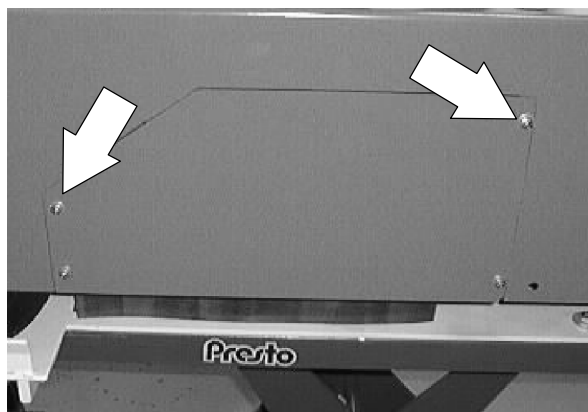

6. Locate the main brush drive belt idler pulley between the small motor drive pulley and the larger brush pulley.

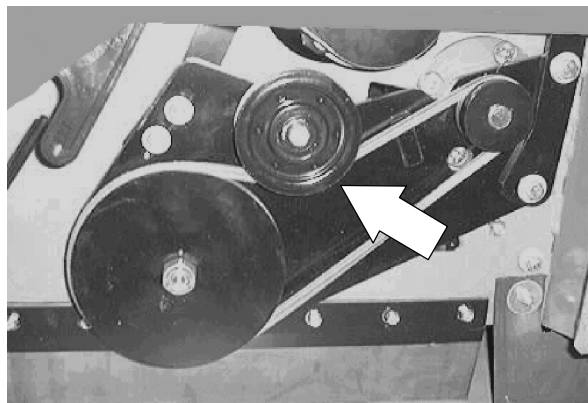

7. Loosen the hex nut in the center of the idler pulley.

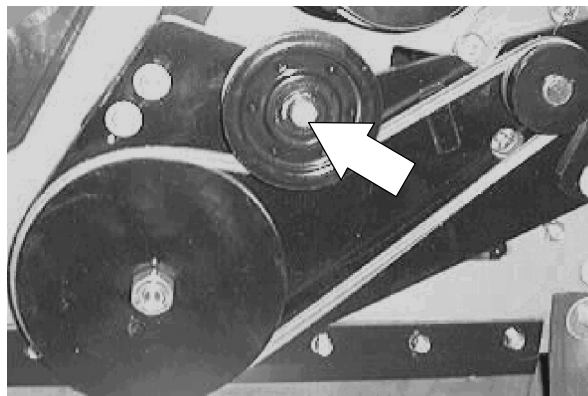

8. Push the idler pulley back in the slot.

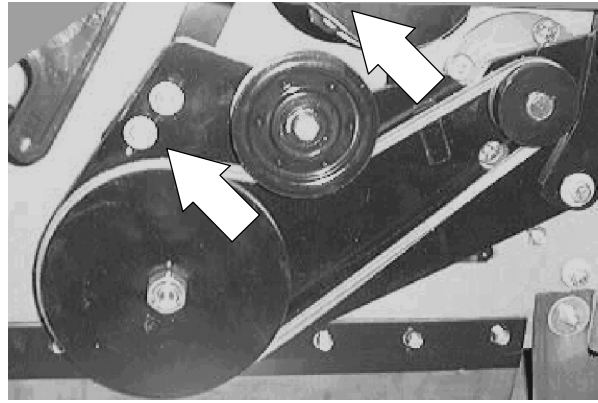

9. Remove the main brush drive belt from the two remaining pulleys. Remove the main brush drive belt.

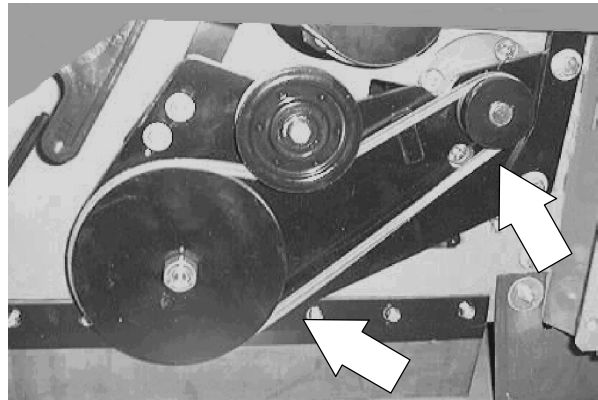

10. Loosen the two set screws holding the small V-belt pulley to the main brush motor shaft. Pull the pulley off the shaft. Retain the square key.

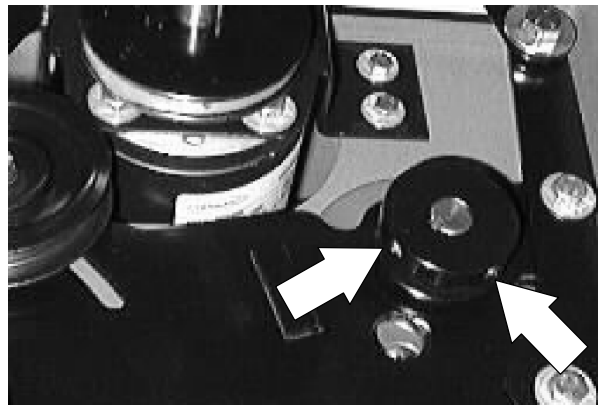

11. Remove the two hex screws holding the brush arm lift link to the front of the brush arm weldment.

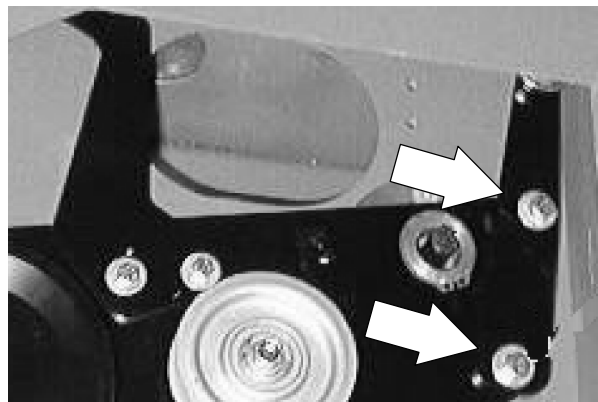

12. Remove the four flat head screws holding the main brush motor to the motor pivot plate and machine frame. *You may have to rotate the brush arm weldment to line up the access holes.*

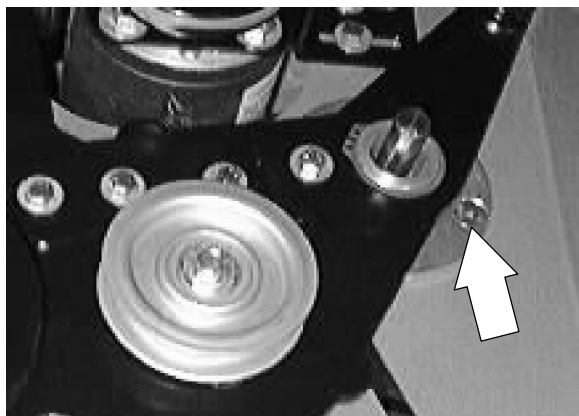

13. Go under the front of the machine and locate the main brush motor behind the front drive assembly. Disconnect the main brush motor from the main harness.

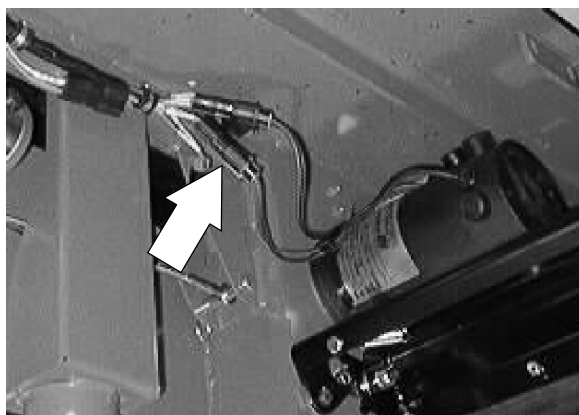

14. Remove the main brush motor from the machine. *Note the orientation of the motor and electrical wires.*

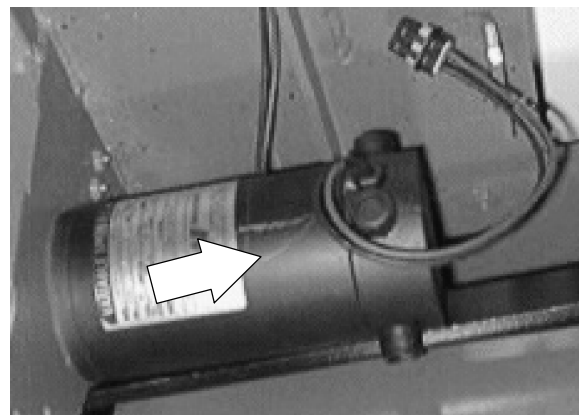

15. Install the new main brush motor into the machine. *Make sure to orientate the motor so the wires are pointed to the front of the machine*

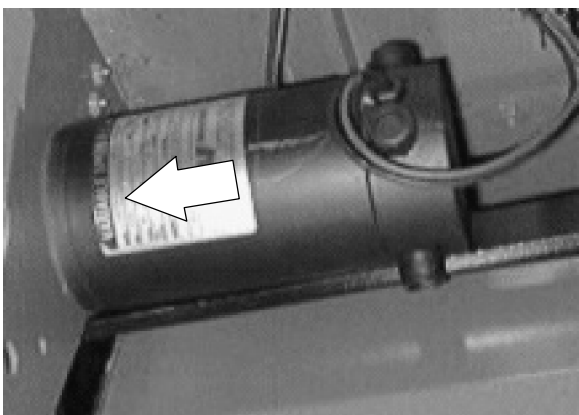

ELECTRICAL

16. Connect the new main brush motor to the main harness.

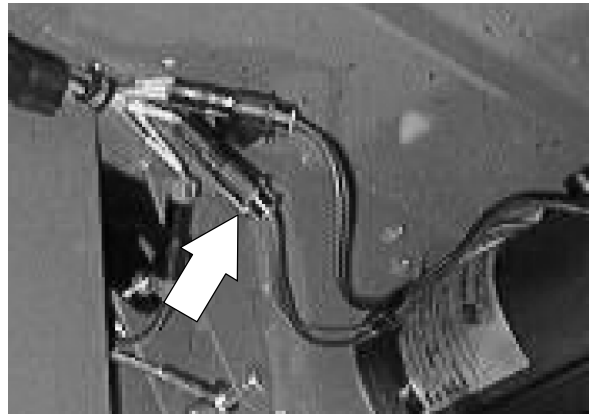

17. Line up the mount holes in the new motor with the mount holes in the machine frame and motor pivot plate. Reinstall the four flat head screws. Tighten to 11 - 14 Nm (7 - 10 ft lb). *You may have to rotate the brush arm weldment to line up the access holes.*

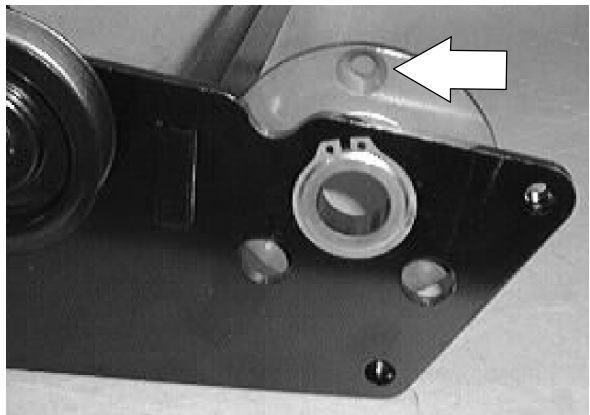

18. Wire tie the motor wires to the motor housing.

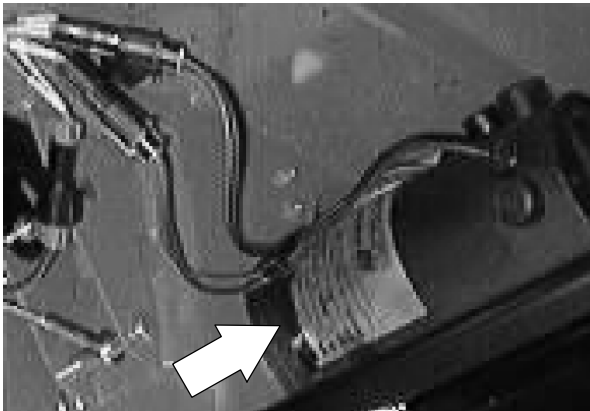

19. Reinstall the small main brush V-belt pulley onto the new main brush motor shaft. Line up the small V-belt pulley with the larger V-belt pulley. Make sure the square key is installed on the shaft. Hand tighten the two set screws.

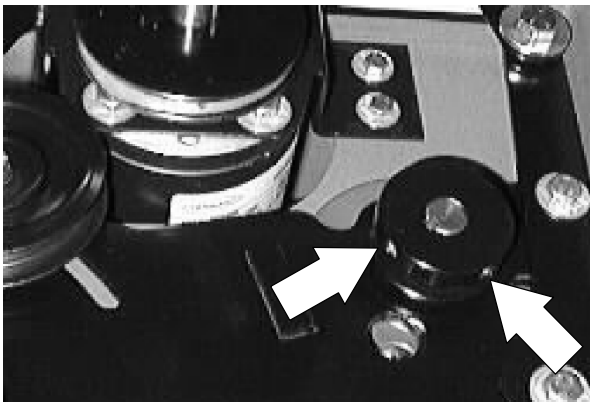

20. Reinstall the brush arm lift link to the front of the brush arm weldment. Reinstall the two hex screws and tighten to 18 - 24 Nm (15 - 20 ft lb).

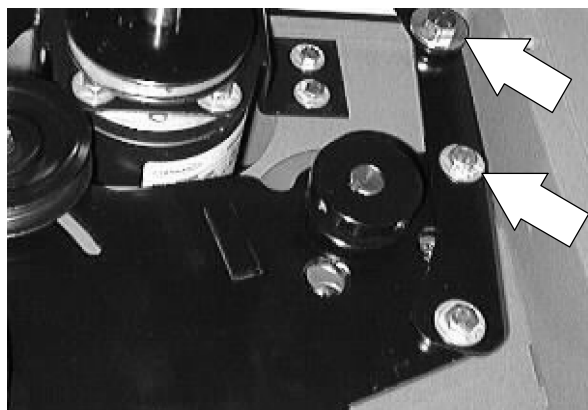

21. Position the main brush drive belt onto the motor and brush drive pulleys.

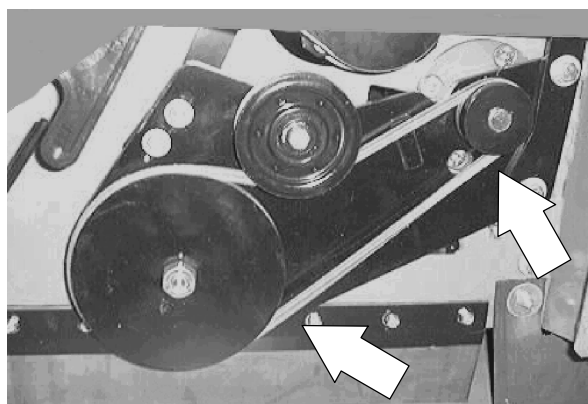

22. Move the idler pulley forward in the slot until the belt is tight. Tighten the hex nut to 18 - 24 Nm (15 - 20 ft lb).

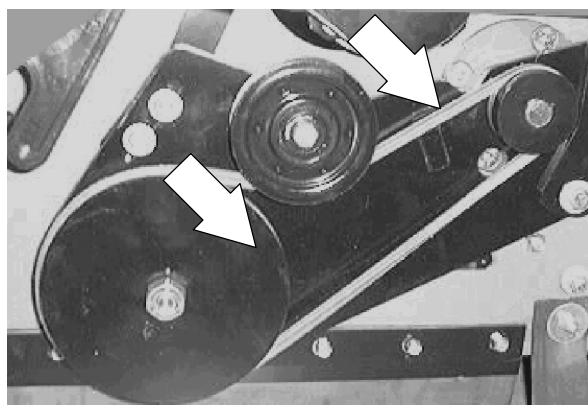

23. Reinstall the right hand side brush door.

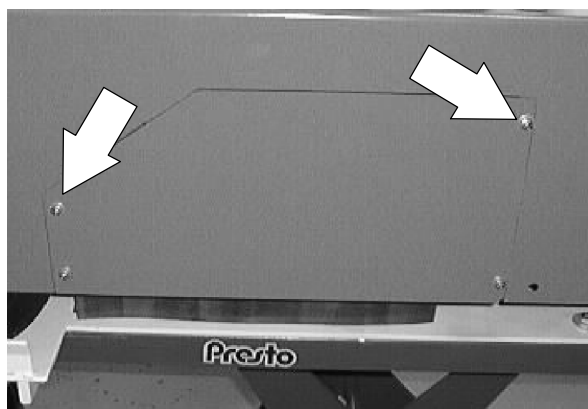

24. Reconnect the batteries.

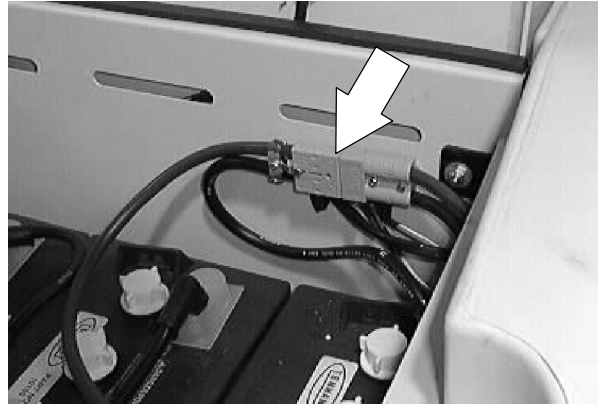

25. Disengage the prop rod and lower the seat support.



26. Remove the jack stands and lower the machine to the floor. Operate the machine and check the new main brush motor for proper operation.

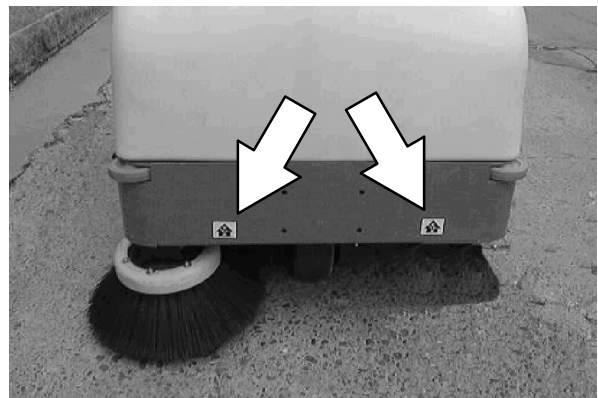

TO REPLACE VACUUM FAN MOTOR

FOR SAFETY: Before Leaving Or Servicing Machine; Stop On Level Surface, Set Parking Brake.

1. **The main brush motor must be removed before the vacuum fan motor can be removed.** See TO REPLACE MAIN BRUSH MOTOR instructions in this section.

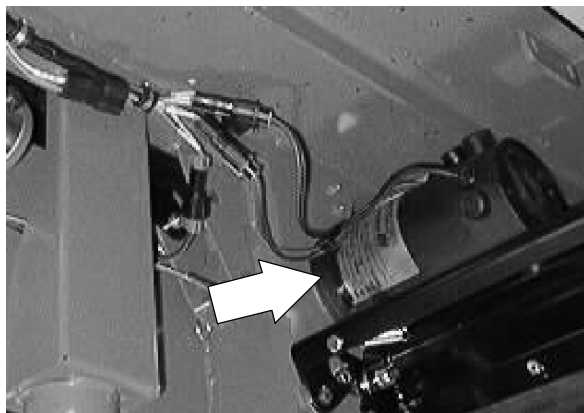

2. Open the seat support and engage the prop rod.



3. Disconnect the machine batteries.

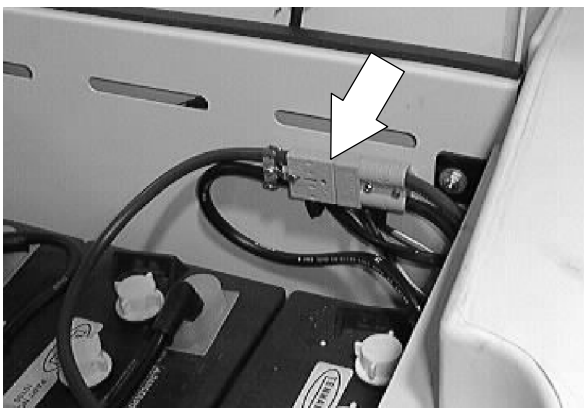

ELECTRICAL

4. To access the vacuum fan drive belt, remove the right hand side panel. Start by lifting up on the panel, pop the brush lift slot over the black knob, then move the panel backward and off the machine.



5. Remove the four screws holding the right hand brush door to the machine frame. Remove the right hand side brush door.

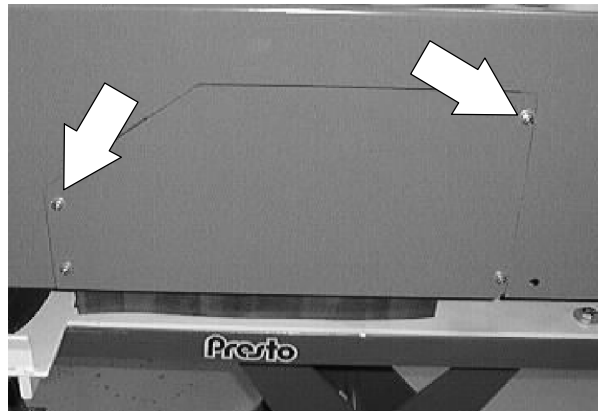

6. Loosen the four hex screws holding the vacuum fan housing to the machine frame.

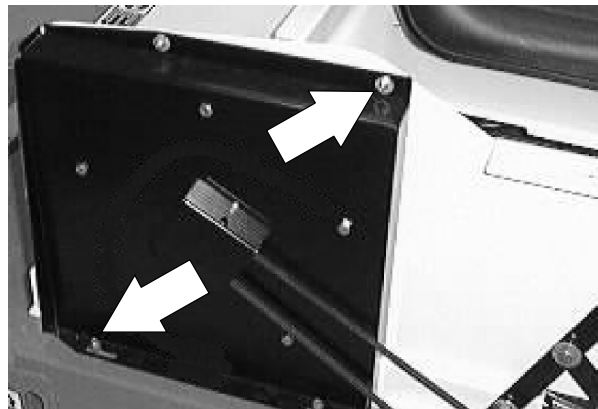

7. Push the vacuum fan assembly forward in the slots to loosen the vacuum fan V-belt.

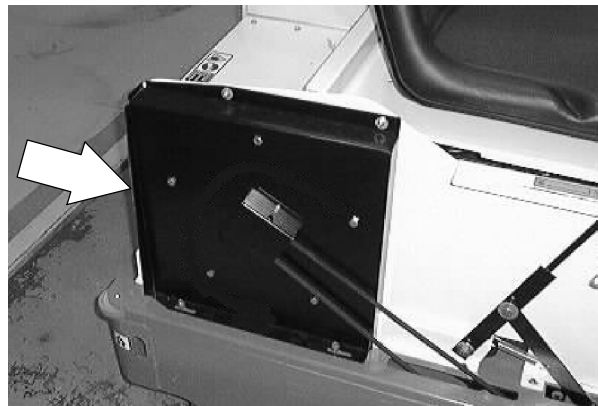

8. Remove the V-belt from the vacuum fan motor pulley.

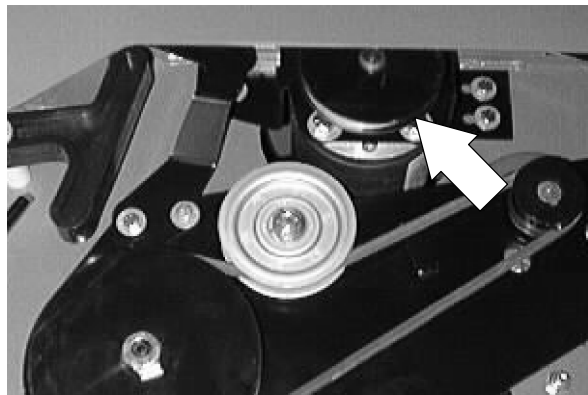

9. Loosen the set screws holding the vacuum fan V-belt pulley to the motor shaft. Remove the pulley off the shaft. Retain the square key.

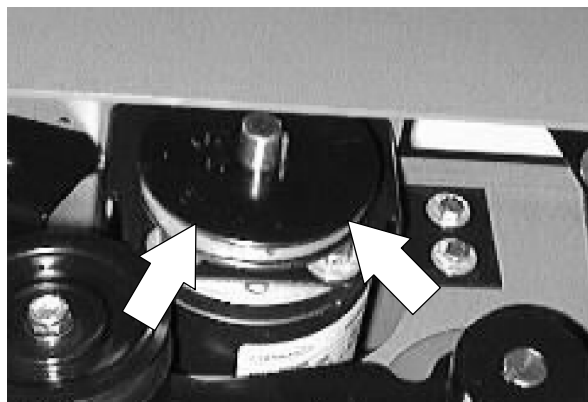

10. Remove the four hex screws holding the vacuum fan motor to the mount bracket.

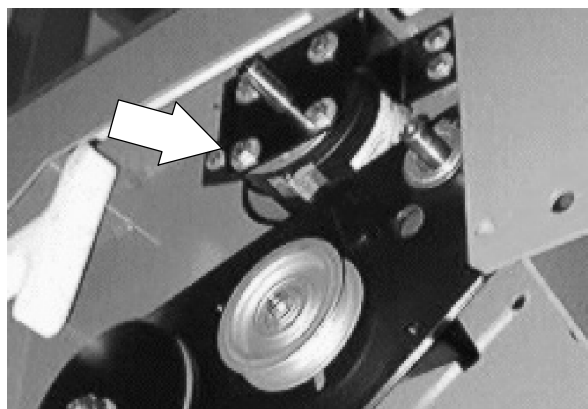

11. Go under the front of the machine and locate the vacuum fan motor behind the front drive assembly. Disconnect the vacuum fan motor from the main harness.



12. Remove the vacuum fan motor from the machine. *Note the orientation of the motor and electrical wires.*

ELECTRICAL

13. Install the new vacuum fan motor into the machine. *Make sure to orientate the motor so the wires are pointed to the front of the machine.*

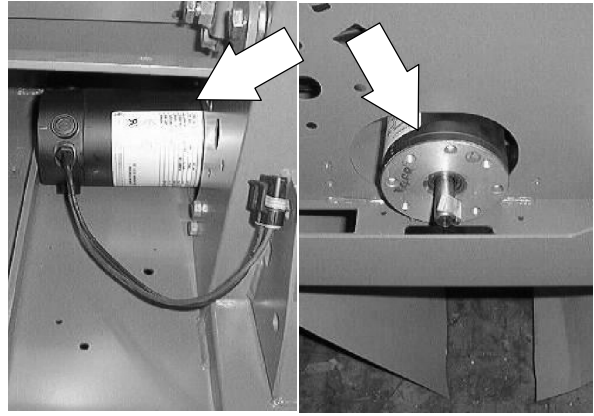

14. Reconnect the vacuum fan motor to the main harness.



15. Line up the mount holes in the new motor with the mount holes in the motor mount bracket. Reinstall the four hex screws. Tighten to 11 - 14 Nm (7 - 10 ft lb).

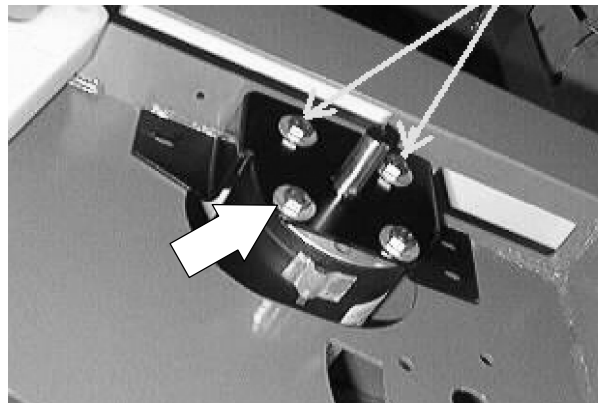

16. Reinstall the vacuum fan V-belt pulley onto the new vacuum fan motor shaft. Line up the V-belt pulley with the V-belt pulley up at the impeller. Make sure the square key is installed on the shaft. Hand tighten the two set screws.

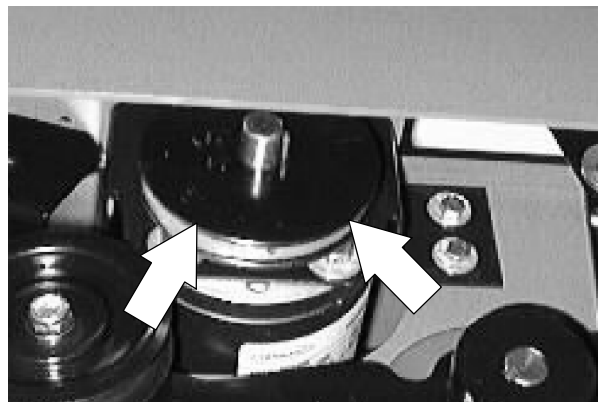

17. Pull the vacuum fan assembly toward the back of the machine to tighten the V-belt. The correct tension is when the belt deflects 8.38 mm (0.33 in) from a force of .42 kg (.90 to .95 lb) at belt midpoint. Tighten the screws hand tight.

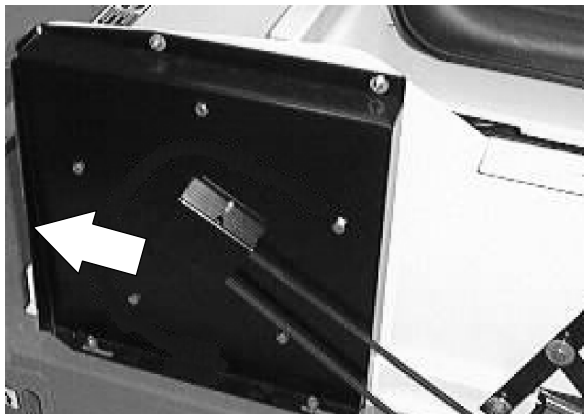

18. Reinstall the right hand side brush door.

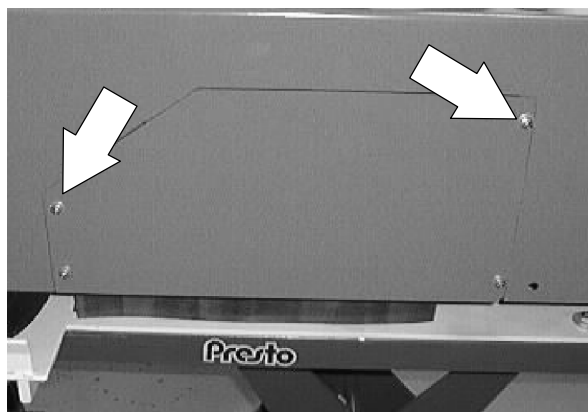

19. Reinstall the right hand machine cover.

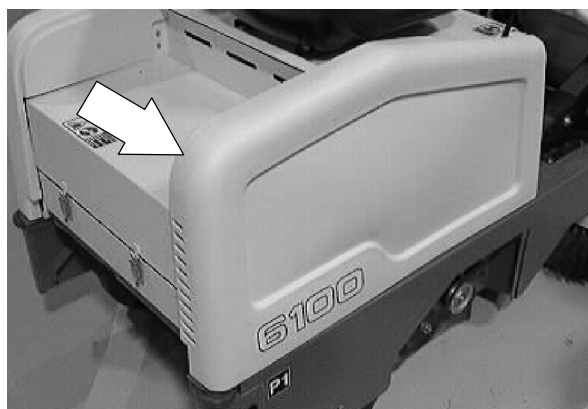

20. Reconnect the batteries.

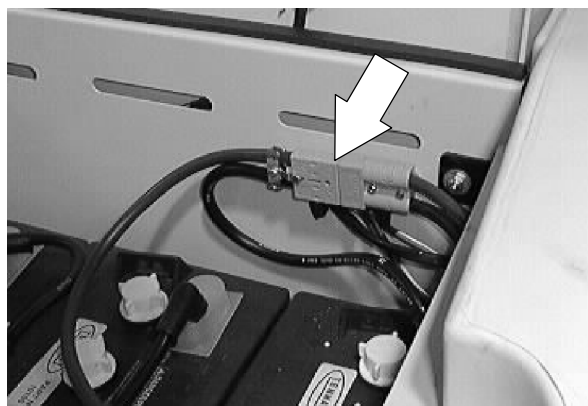

21. Disengage the prop rod and lower the seat support.



22. Remove the jack stands and lower the machine to the floor. Operate the machine and check the new vacuum fan motor for proper operation.

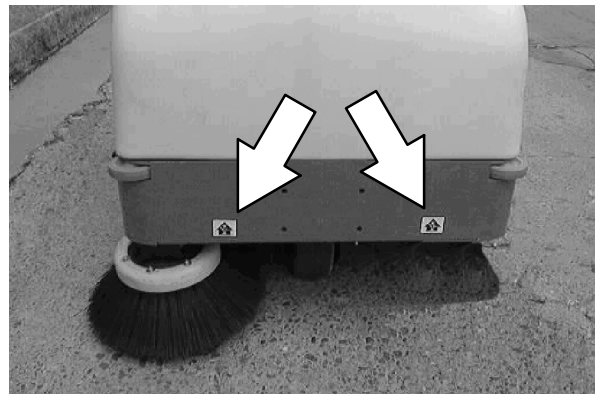

TO REPLACE SIDE BRUSH MOTOR

FOR SAFETY: Before Leaving Or Servicing Machine; Stop On Level Surface, Set Parking Brake.

1. Jack up the front of the machine at the jack point. Install jack stands under the machine frame.

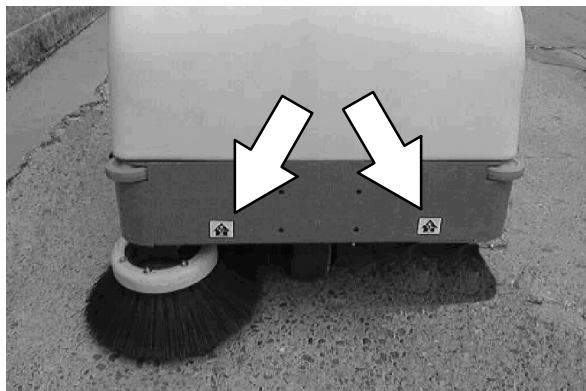

2. Lower the side brush.

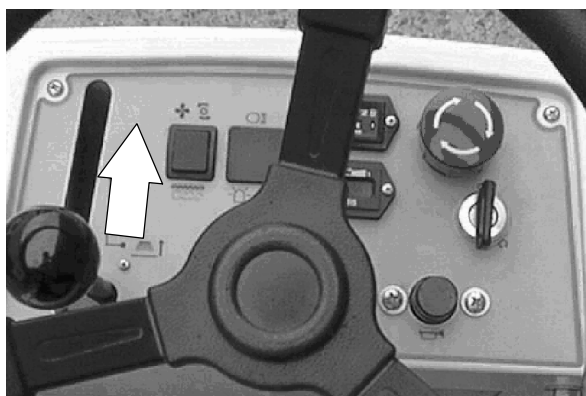

3. Remove the side brush from the motor assembly. See TO REPLACE SIDE BRUSH instructions in the SWEEPING section.



ELECTRICAL

4. Disconnect the side brush motor from the main wire harness.

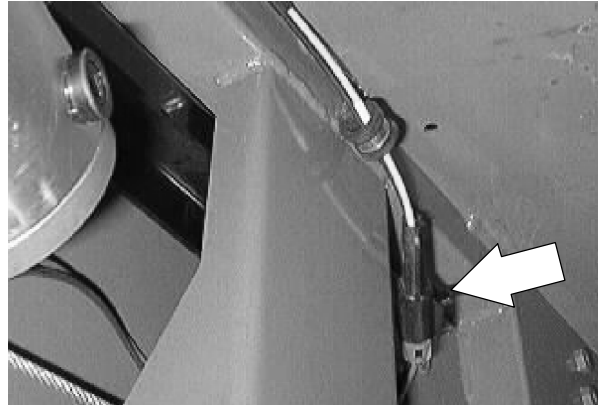

5. Remove the four hex screws holding the side brush motor to the motor mount bracket.

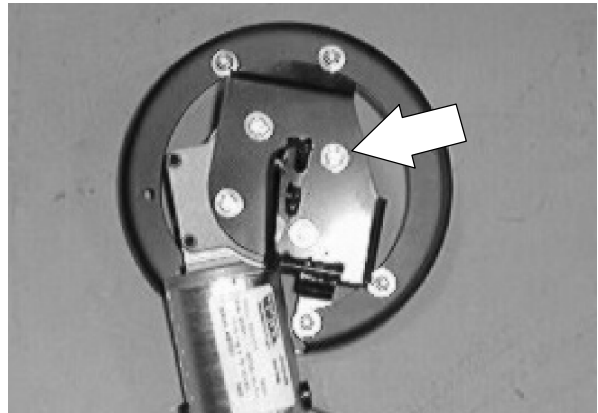

6. Drop the motor out of the mount bracket and past the brush guard.

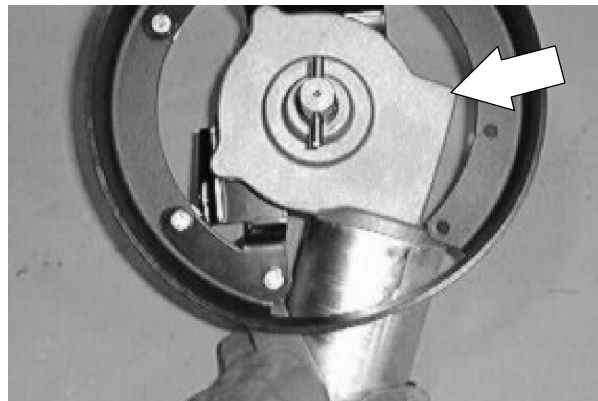

7. Position the new side brush motor onto the motor mount bracket. The motor is positioned to the rear of the machine.

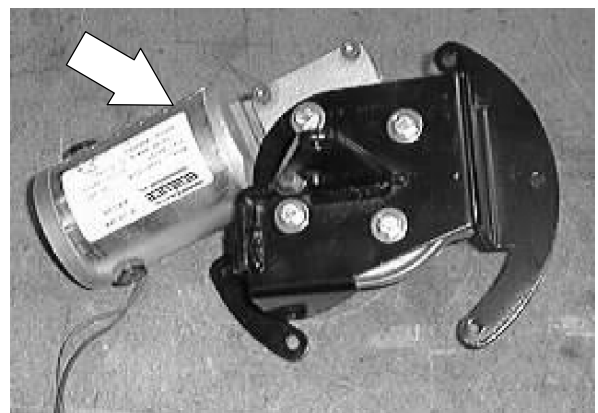

- Line up the holes in the motor assembly with the mount holes in the motor bracket. Reinstall the four hex screws and tighten to 8 - 10 Nm (6 - 7 ft lb).

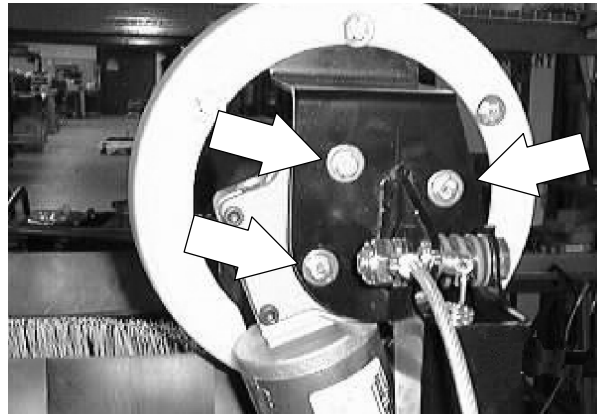

- Reconnect the side brush motor to the main harness.

- Wire tie the motor wires to the motor housing.

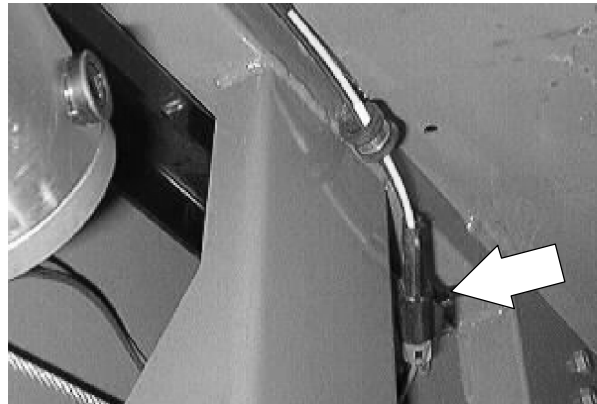

- Reinstall the side brush. See TO REPLACE SIDE BRUSH instructions in the SWEEPING section.



- Operate the machine. Check the side brush for proper operation.



ELECTRICAL SCHEMATIC

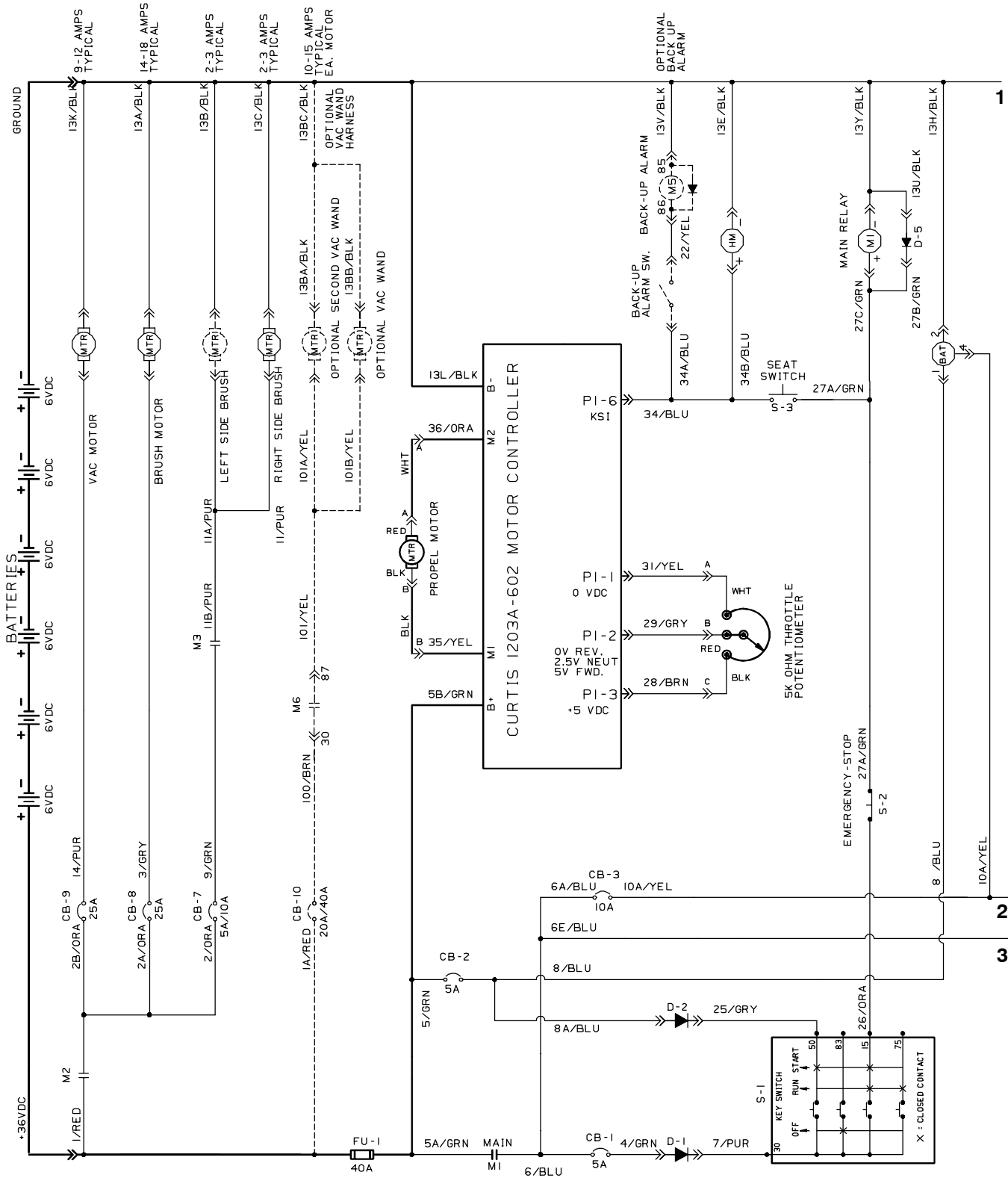

ELECTRICAL SCHEMATIC

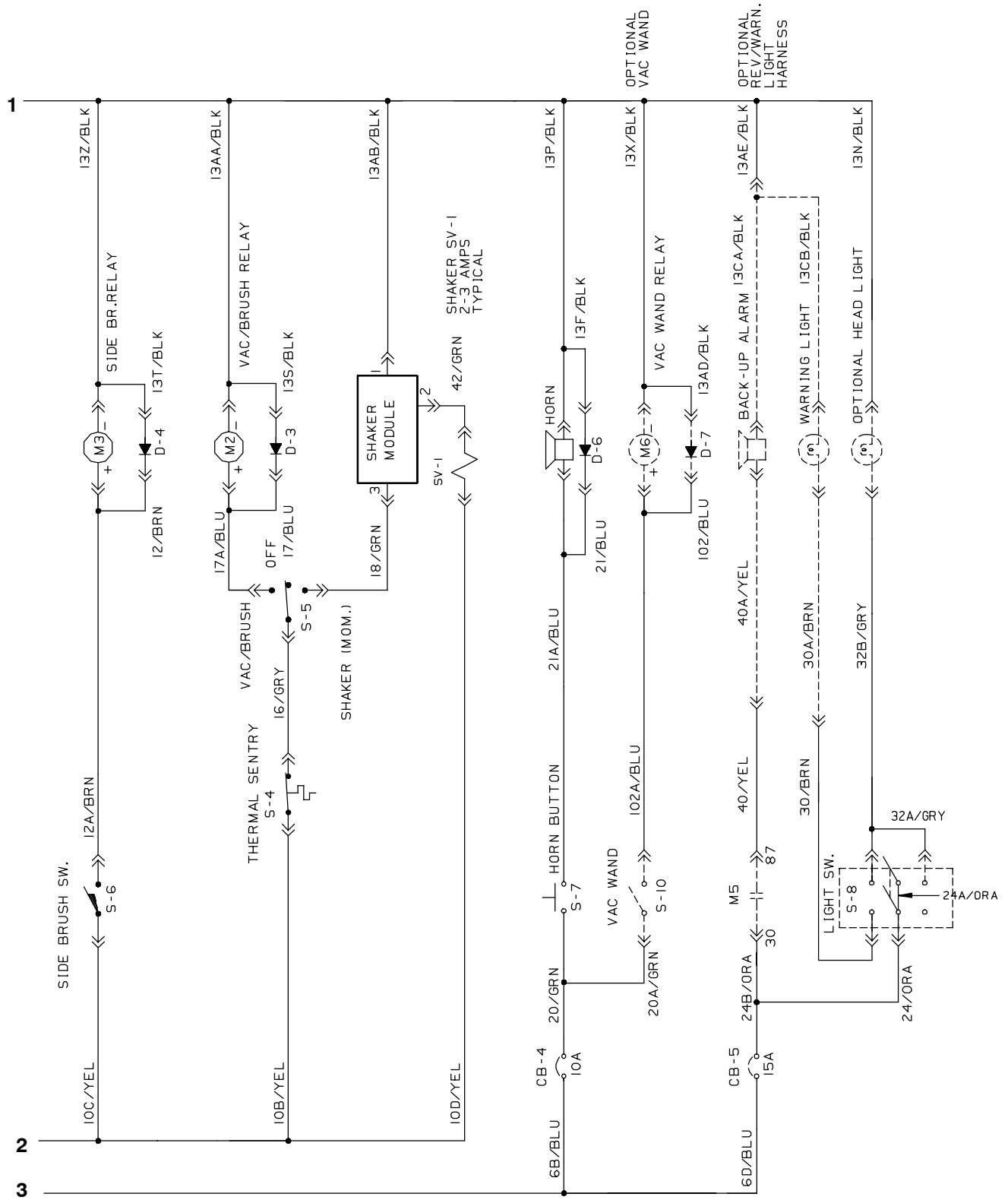

LEGEND

CB	CIRCUIT BREAKER	FU	FUSE
MTR	MOTOR	D	DIODE
P	CONNECTOR PIN	M	RELAY COIL
S	SWITCH	R	RESISTOR
ARM	ARMATURE	HM	HOURMETER
BAT	BATTERY GAUGE		

OPTIONAL
BACKUP ALARM
AND LIGHTS

WIRE HARNESS

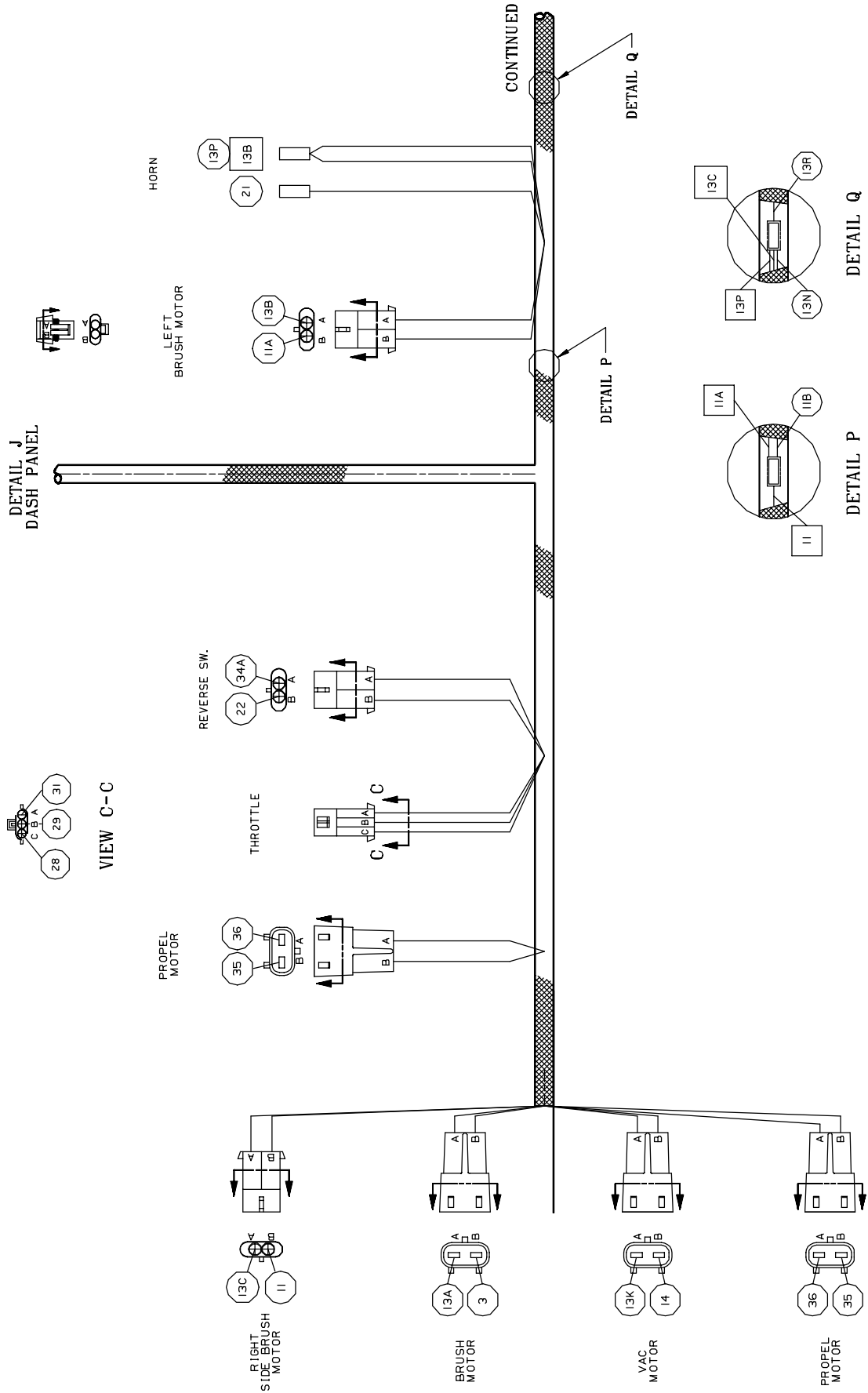

WIRE HARNESS

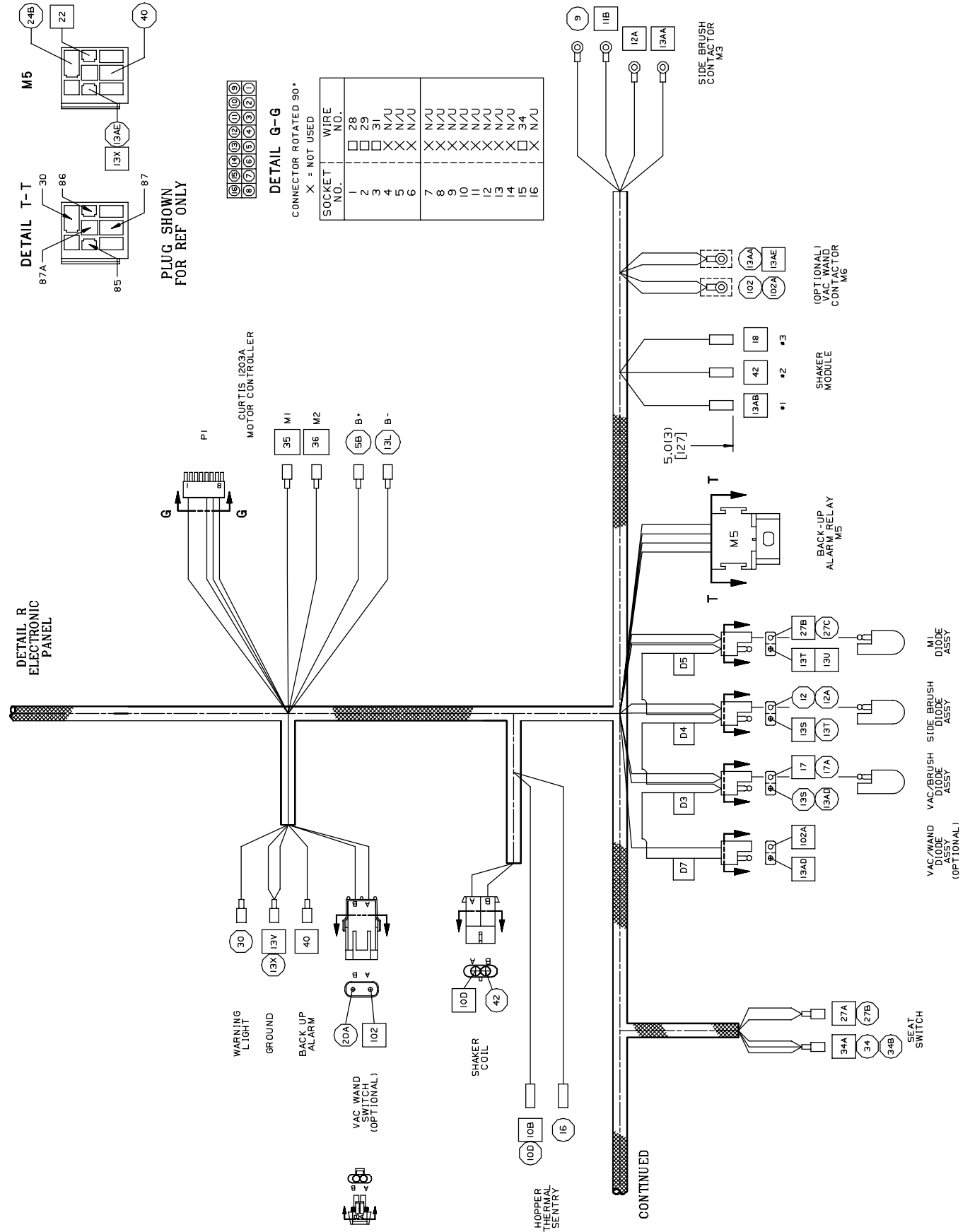

DETAIL G-G
CONNECTOR ROTATED 90°
X = NOT USED

SOCKET NO.	WIRE NO.
1	28
2	29
3	31
4	N/U
5	N/U
6	N/U
7	N/U
8	N/U
9	N/U
10	N/U
11	N/U
12	N/U
13	N/U
14	N/U
15	N/U
16	N/U

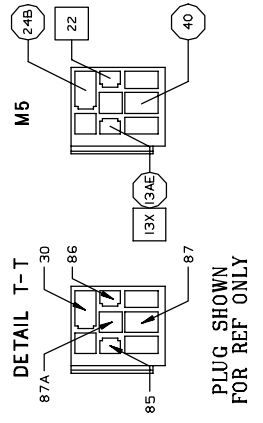

DETAIL R ELECTRONIC PANEL

CONTINUED

WIRE HARNESS

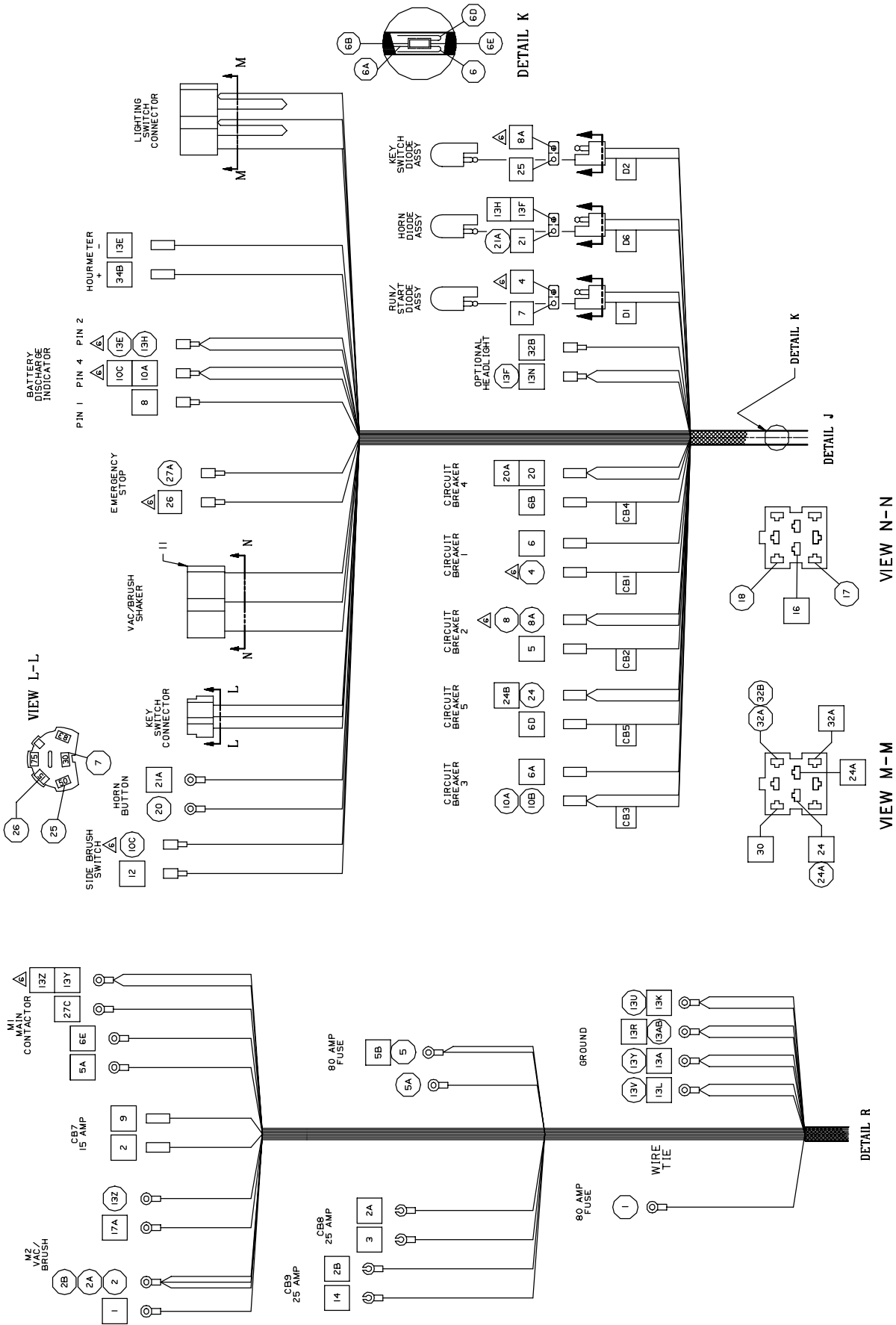

TROUBLESHOOTING

The troubleshooting charts that follow are organized so they lead you through the circuits. They include flow charts and instructions for you as to where to insert your test instruments.

NO PROPEL OR SWEEP FUNCTION AT MACHINE POWER UP

NORMAL OPERATION:

1. Cycling the keyswitch to the start position will switch B+ voltage from the keyswitch pin 50 to the keyswitch pin 15. This will turn on M1 relay.
2. The closed M1 relay contacts supply B+ voltage to the keyswitch pin 30, and through the keyswitch to pin 15. This will keep M1 relay on.
3. M1 will stay on until fuse-1, CB-1, the keyswitch or the emergency stop switch open up, breaking the current path of M1 and turning off the machine.

TURN KEYSWITCH TO START POSITION THEN
RELEASE TO THE ON POSITION.

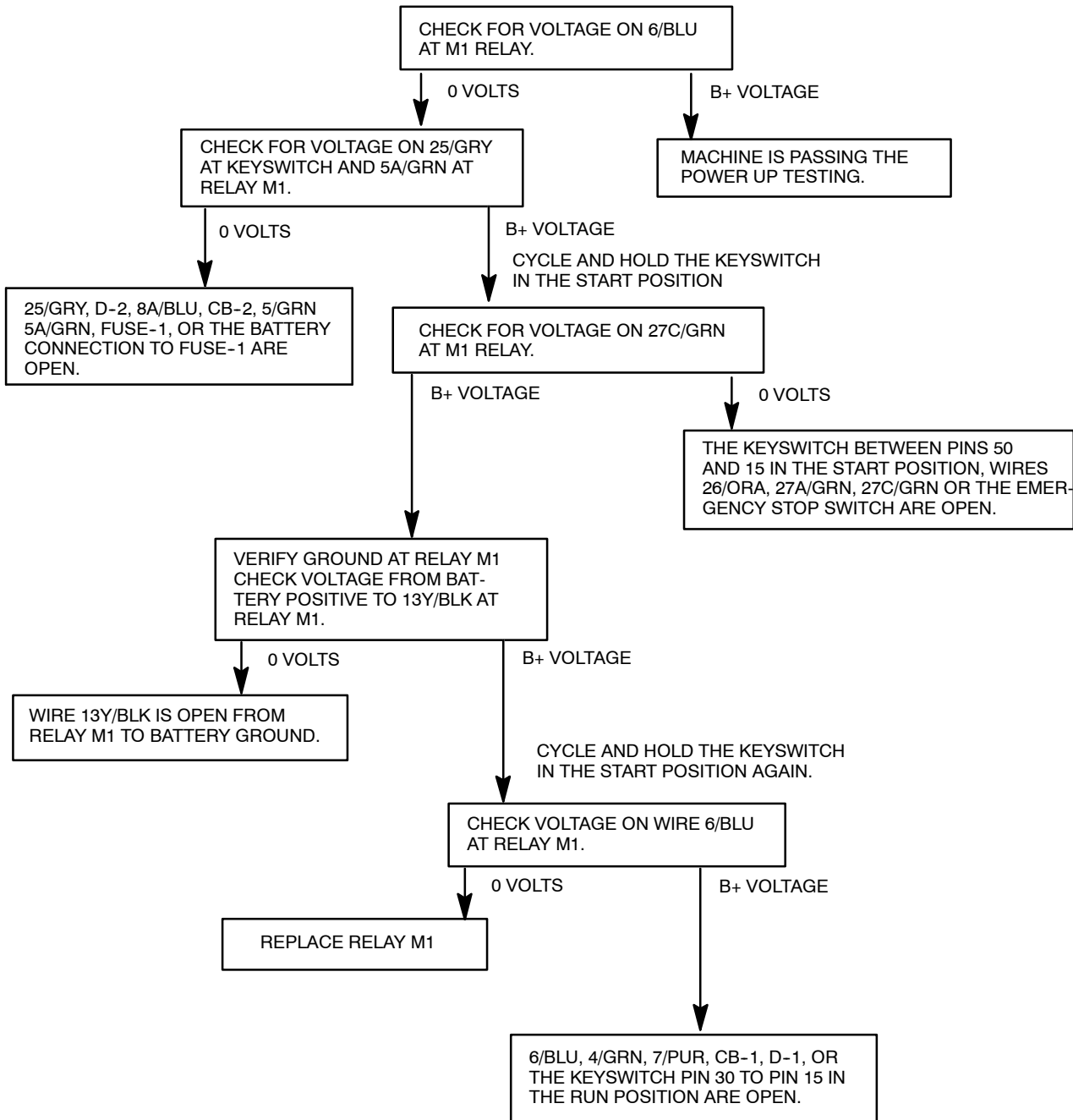

NO PROPEL AT MACHINE POWER UP (STANDARD CONTROLLER)

NORMAL OPERATION:

1. With throttle potentiometer in the neutral position (2.5V on P1-2) M1 and M2 are held at B+ voltage, and the motor does not move.
2. With throttle potentiometer in the forward position (2.5V to 5.0V on P1-2) M1 is held at B+ voltage, and M2 is pulsed to ground. The voltage applied to the motor is proportional to how high the throttle voltage goes above 2.5VDC.
3. With throttle potentiometer in the reverse position (2.5V to 0V on P1-2) M2 is held at B+ voltage and M1 is pulsed to ground. The voltage applied to the motor is proportional to how low the throttle voltage goes below 2.5VDC.

NOTE: THE CONTROLLER MUST SEE A NEUTRAL SIGNAL FROM THE THROTTLE POTENTIOMETER (2.5VDC ON P1-2) AFTER POWER UP OR IT WILL NOT PROPEL FORWARD OR REVERSE.

NOTE: DISCONNECT THE PROPEL MOTOR OR LIFT THE PROPEL WHEEL OFF THE FLOOR BEFORE PROCEEDING WITH THESE TESTS.

NOTE: THE MACHINE IS PASSING THE POWER UP TESTING.

TURN KEYSWITCH TO START POSITION THEN RELEASE TO THE ON POSITION.
NOTE: THE SEAT SWITCH MUST BE ACTIVATED FOR ALL OF THIS TESTING.

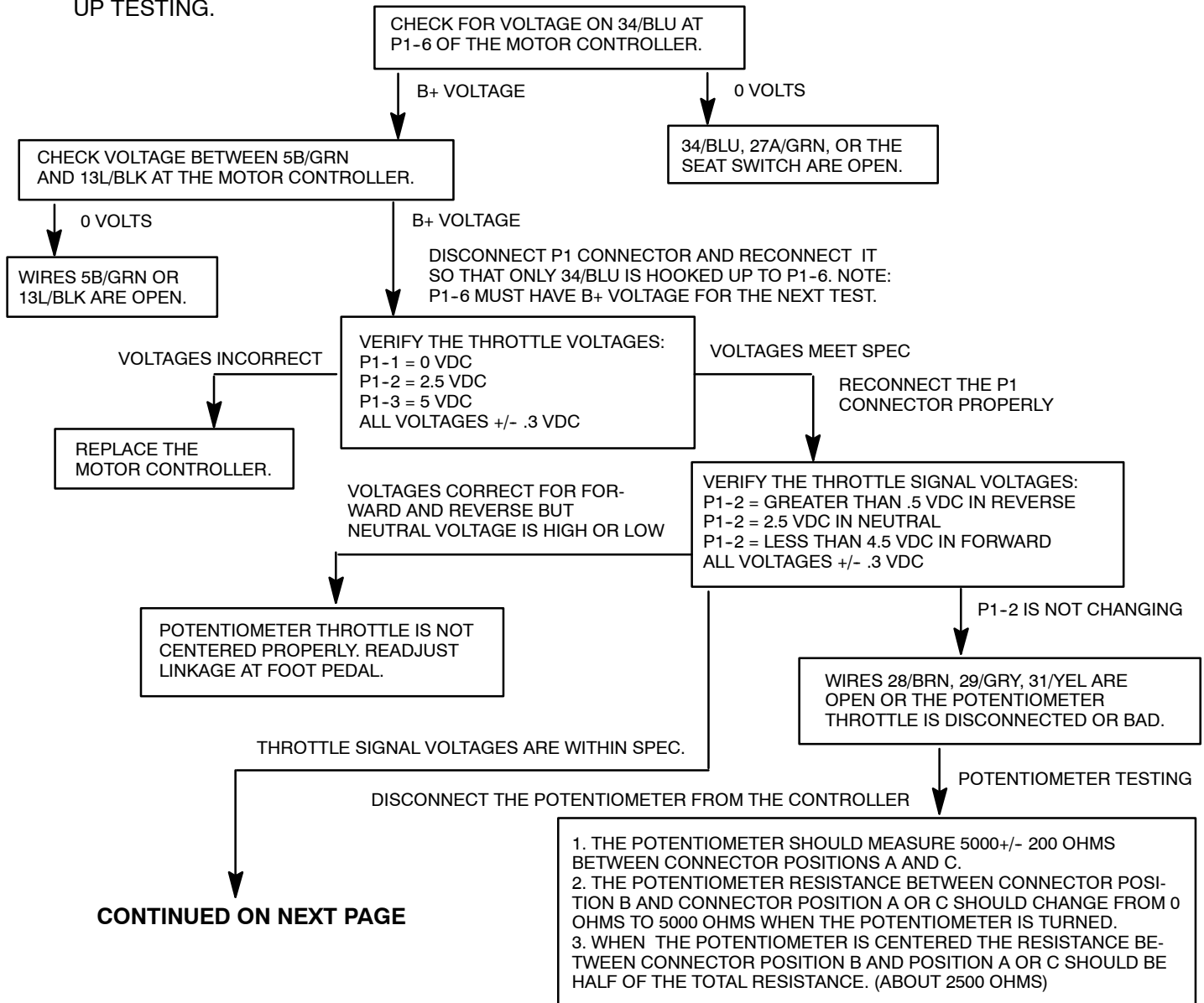

CONTINUED FROM PREVIOUS PAGE

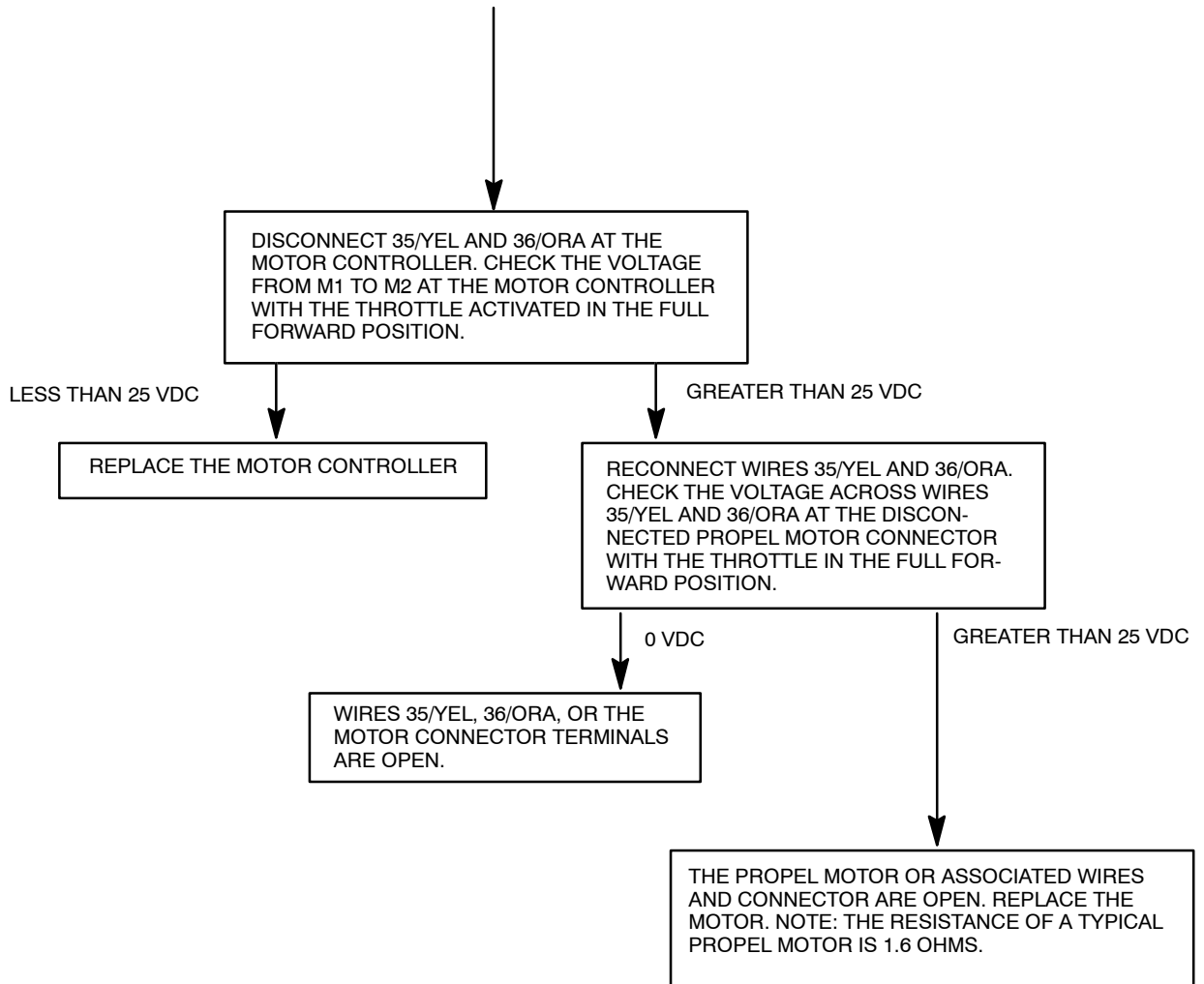

NO PROPEL AT MACHINE POWER UP (HEAVY DUTY CONTROLLER)

NORMAL OPERATION:

1. With throttle potentiometer in the neutral position (2.5V on P1-2) M1 and M2 are held at B+ voltage, and the motor does not move.
2. With throttle potentiometer in the forward position (2.5V to 5.0V on P1-2) M1 is held at B+ voltage, and M2 is pulsed to ground. The voltage applied to the motor is proportional to how high the throttle voltage goes above 2.5VDC.
3. With throttle potentiometer in the reverse position (2.5V to 0V on P1-2) M2 is held at B+ voltage and M1 is pulsed to ground. The voltage applied to the motor is proportional to how low the throttle voltage goes below 2.5VDC.

NOTE: THE CONTROLLER MUST SEE A NEUTRAL SIGNAL FROM THE THROTTLE POTENTIOMETER (2.5VDC ON P1-2) AFTER POWER UP OR IT WILL NOT PROPEL FORWARD OR REVERSE.

NOTE: DISCONNECT THE PROPEL MOTOR OR LIFT THE PROPEL WHEEL OFF THE FLOOR BEFORE PROCEEDING WITH THESE TESTS.

TURN KEYSWITCH TO START POSITION THEN RELEASE TO THE ON POSITION.
NOTE: THE SEAT SWITCH MUST BE ACTIVATED FOR ALL OF THIS TESTING.

NOTE: THE MACHINE IS PASSING THE POWER UP TESTING.

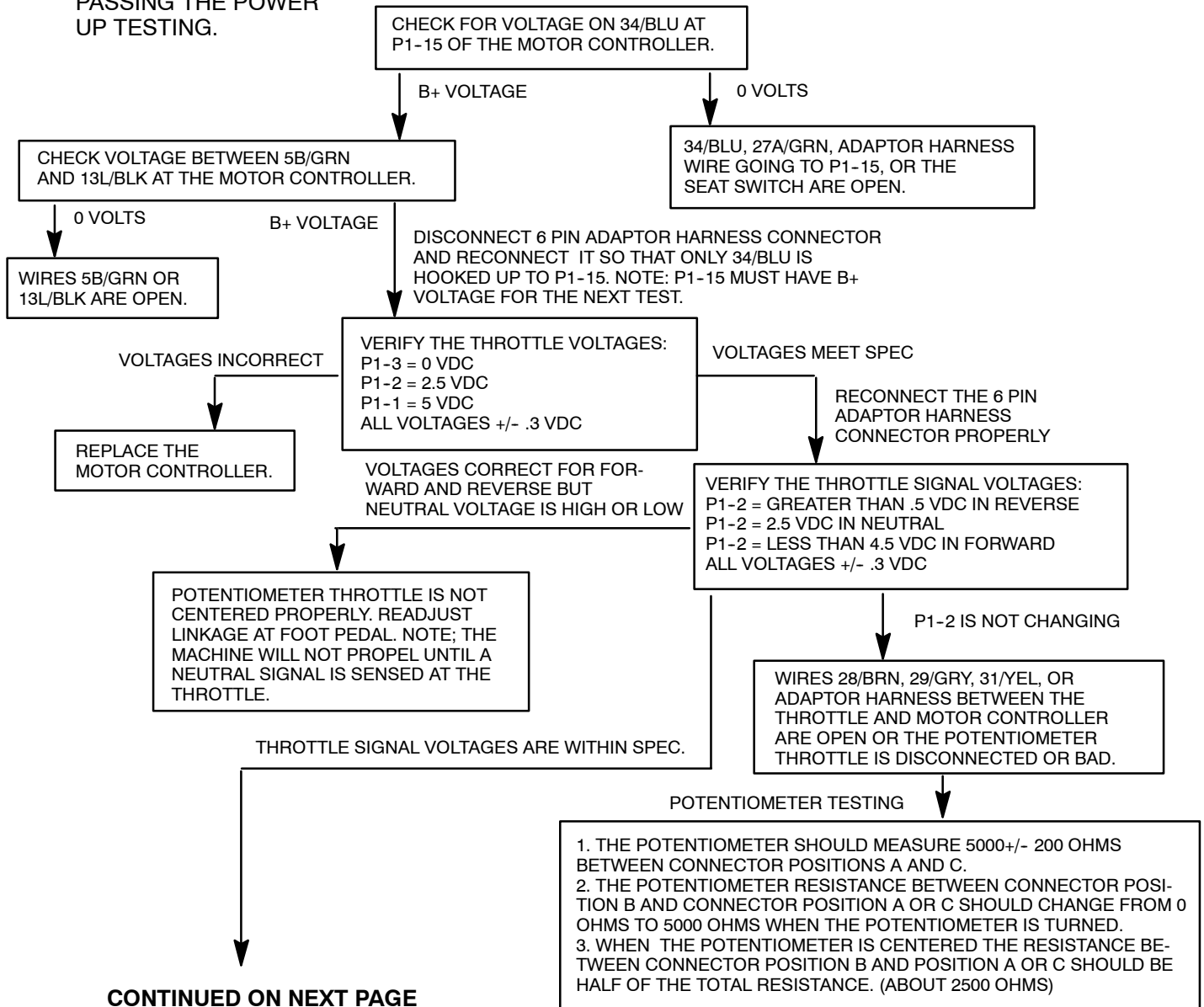

CONTINUED FROM PREVIOUS PAGE

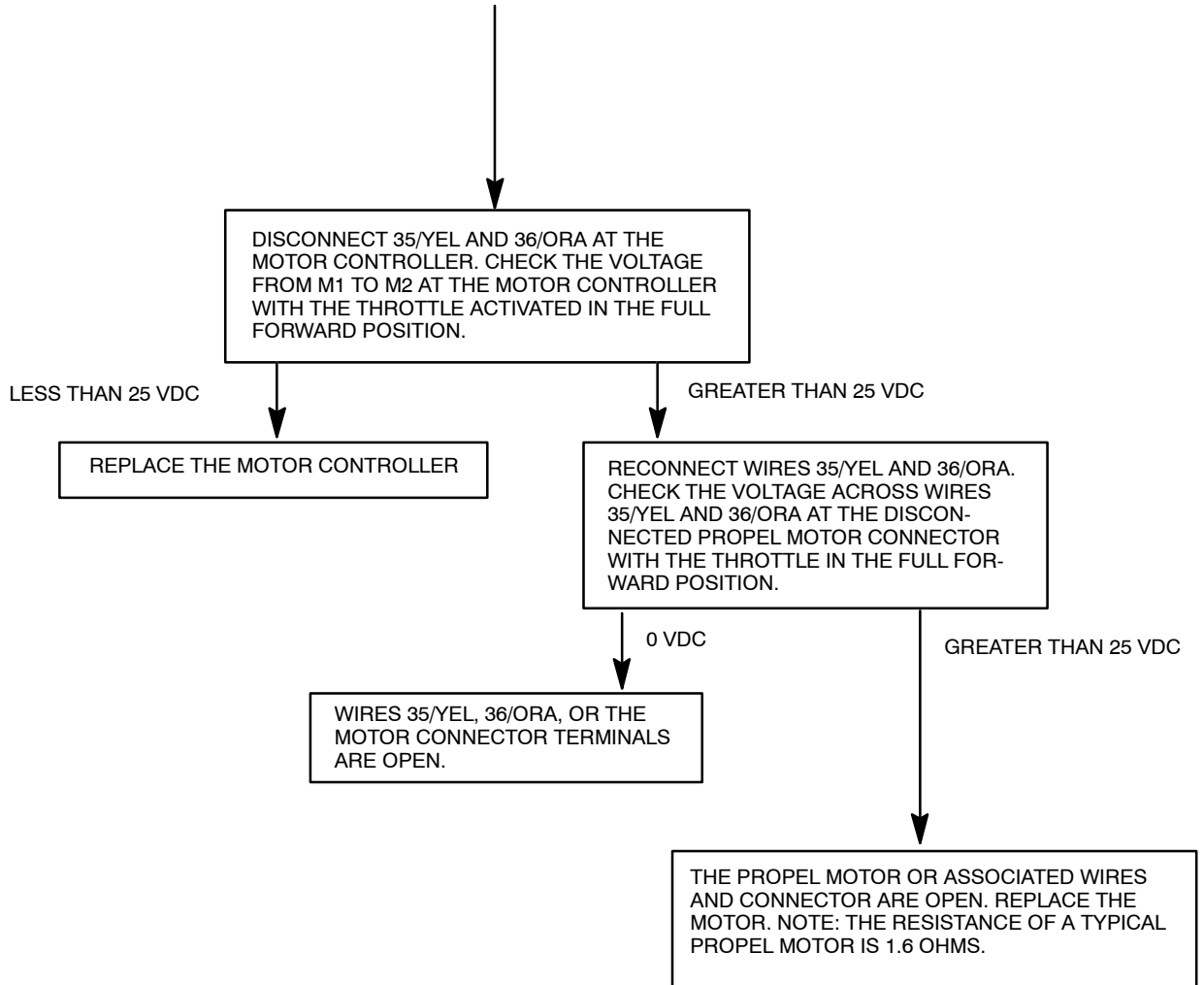

MAIN BRUSH IS NOT OPERATING

NORMAL OPERATION:

1. The vacuum fan main brush switch turns on relay M2.
2. Relay M2 supplies power to the main brush motor.

TURN KEYSWITCH TO START POSITION THEN RELEASE TO THE ON POSITION.

NOTE: THE MACHINE POWERS UP AND PROPELS

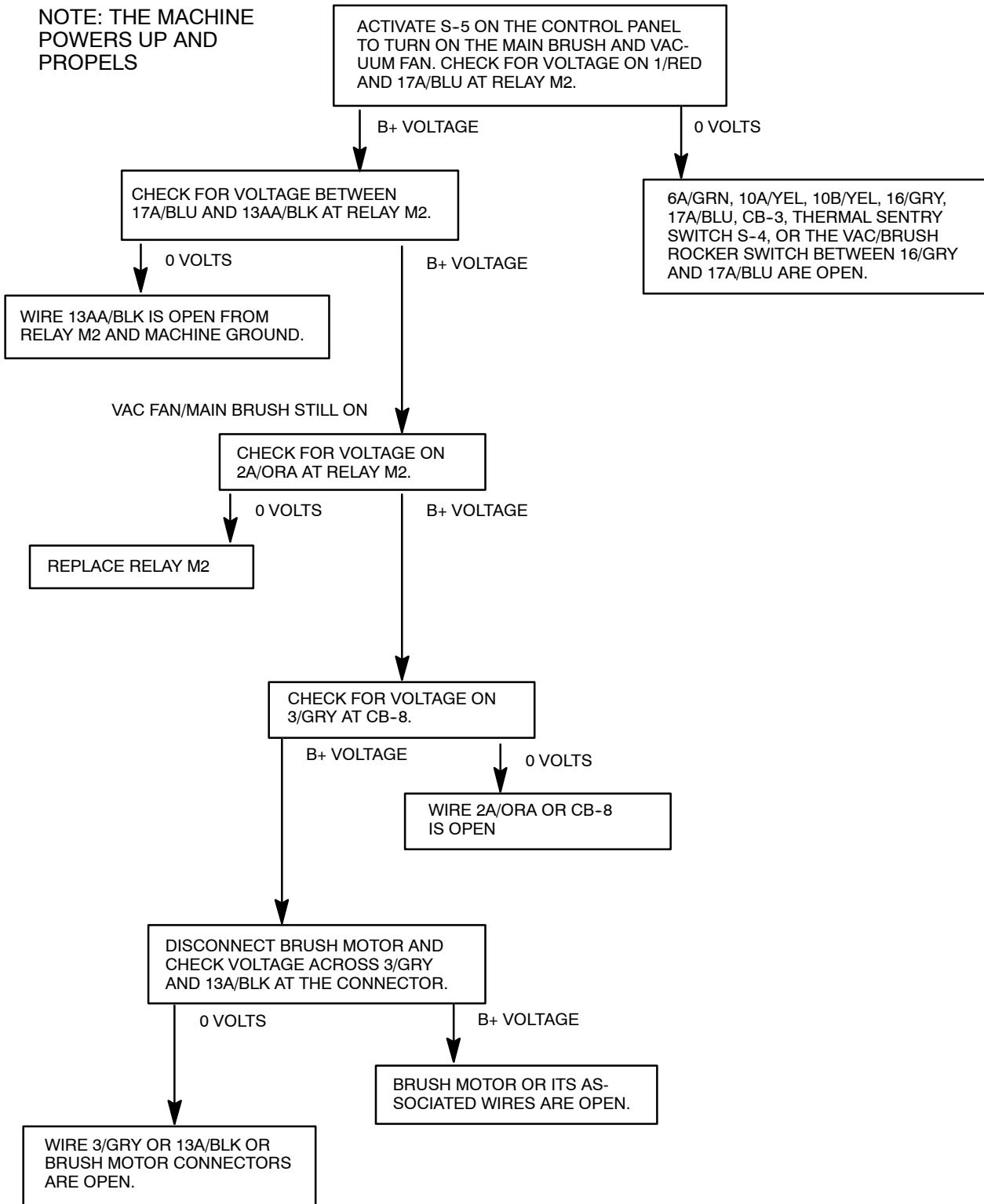

SIDE BRUSH IS NOT OPERATING

NORMAL OPERATION:

1. With vacuum fan and brush on, lowering the side brush lever will activate limit switch S-6, and turn on relay M3.
2. Relay M3 supplies power to the side brush motors.

TURN KEYSWITCH TO START POSITION THEN
RELEASE TO THE ON POSITION
TURN ON THE VACUUM FAN AND MAIN BRUSH,
LOWER THE SIDE BRUSH LEVER.

NOTE: THE MACHINE
PROPELS AND MAIN
BRUSH IS OPERATING

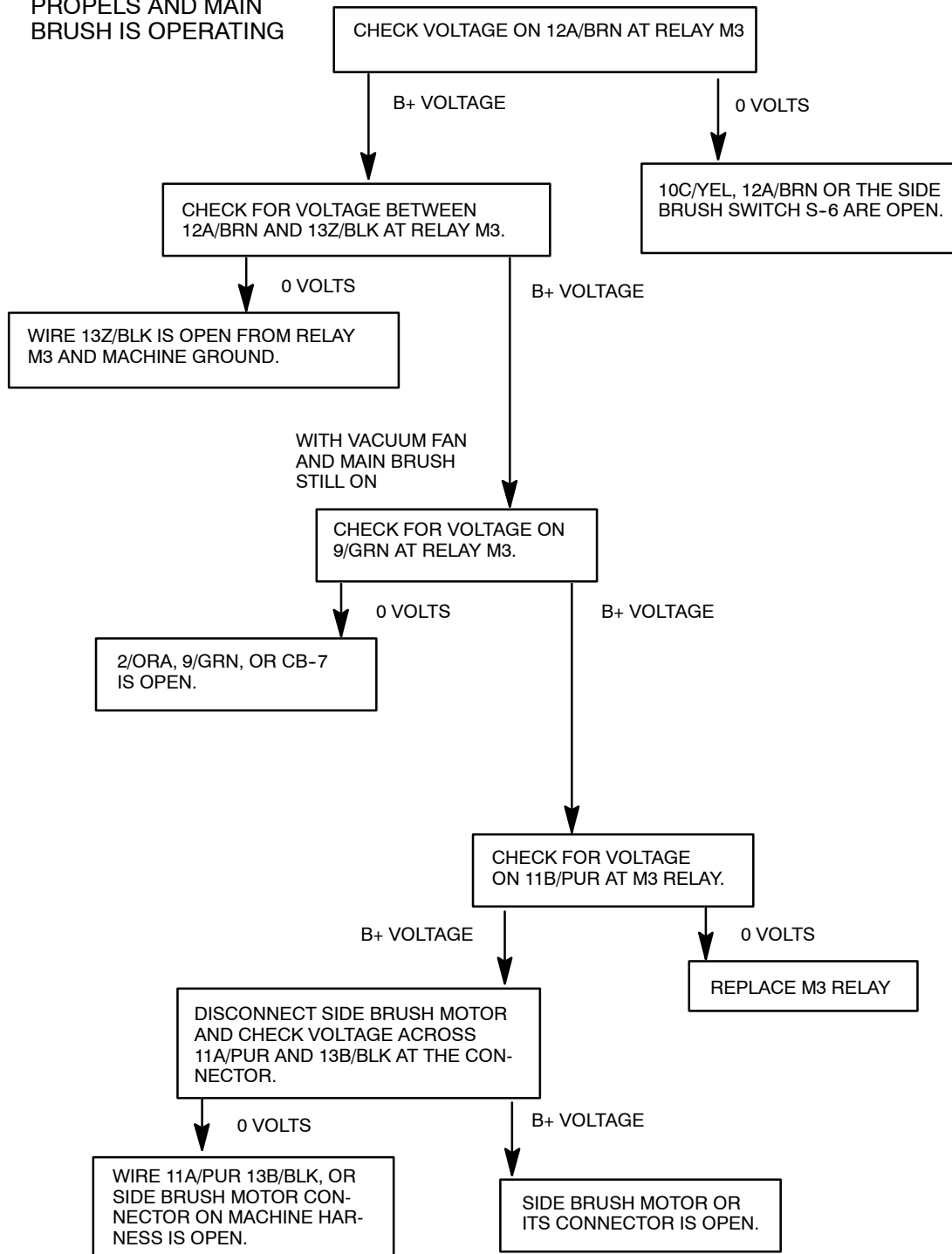

VACUUM FAN IS NOT OPERATING

NORMAL OPERATION:

1. The vacuum fan main brush switch turns on relay M2.
2. Relay M2 supplies power to the vacuum fan motor.

NOTE: THE MACHINE PROPELS

TURN KEYSWITCH TO START POSITION THEN RELEASE TO THE ON POSITION.

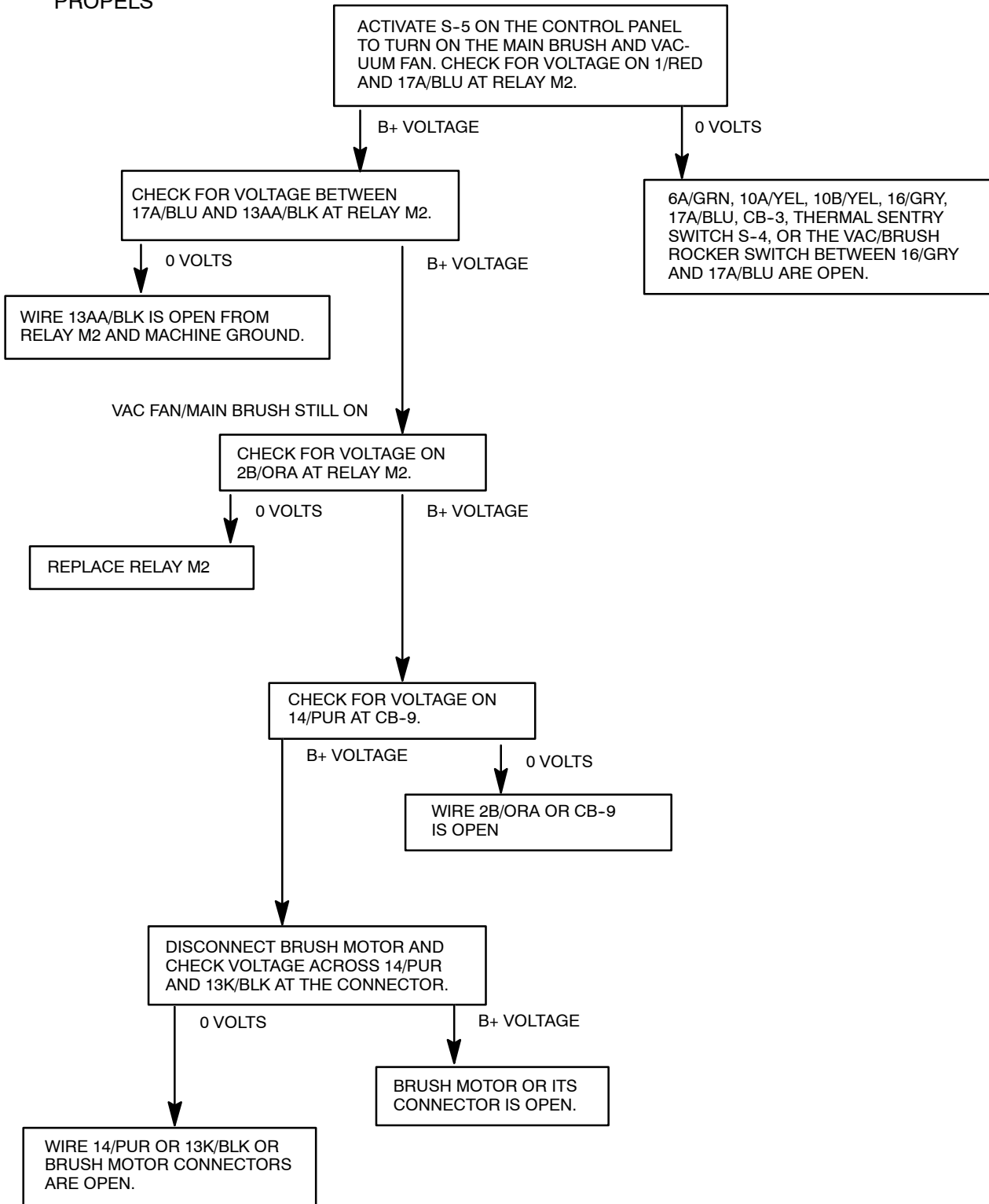

SHAKE SYSTEM NOT OPERATING

NORMAL OPERATION:

1. With the keyswitch on, the operator selects shake by activating and holding switch S-5 on the front panel.
2. B+ voltage is supplied to pin 3 of the shaker module, turning on the shaker module..
3. Pin 2 of the shaker module is pulsed to ground (pin 1).
4. The shaker solenoid is turned on and off at a high frequency, moving the filter bar back and forth.

NOTE: THE MACHINE PROPELS AND VAC FAN AND MAIN BRUSH OPERATE PROPERLY

TURN KEYSWITCH TO START POSITION AND RELEASE TO RUN POSITION. SELECT AND HOLD S-5 IN THE MOMENTARY SHAKE POSITION

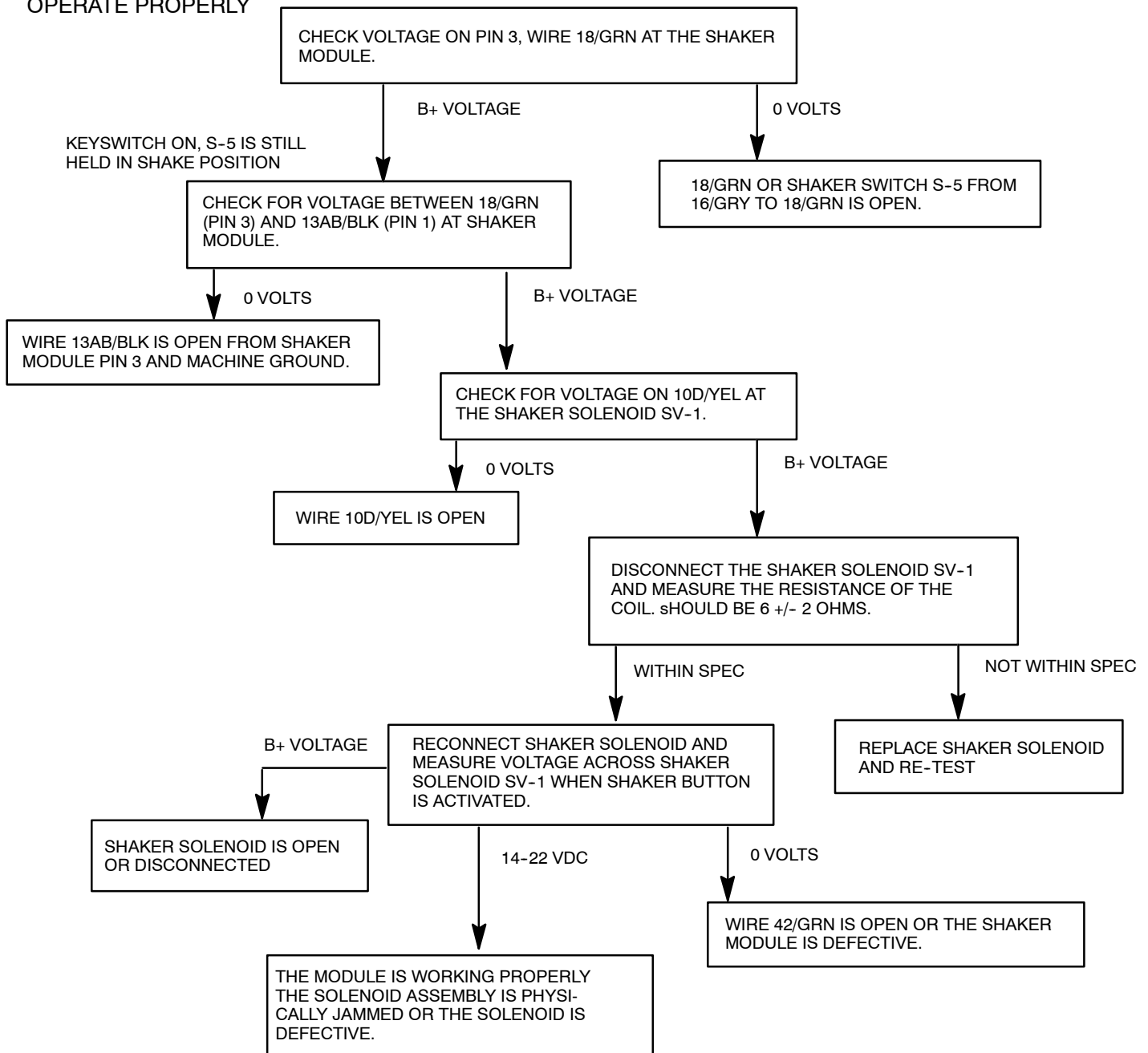

NOTE: IF THE SHAKER SYSTEM WORKS FOR A SHORT DURATION, THEN STOPS OR SLOWS, THE SHAKER COIL IS DRAWING EXCESSIVE CURRENT. REPLACE THE SHAKER COIL.



We Need Your Help...

As part of Tennant’s Zero Defects Program, we want to know about errors you have found or suggestions you may have regarding our machine manuals. If you find an error or have a suggestion, please complete this postage-paid form and mail it to us. Thank you for helping us make zero defects a way of life at Tennant.

Manual No. _____ Rev. No. _____ Publish Date _____ Page _____
Machine _____ Report Error Suggestion

Name _____ Date _____

Customer Number _____

Company _____

Address _____

City/State/Zip Code _____



TENNANT COMPANY
 Technical Publications #15
 701 North Lilac Drive
 P.O. Box 1452
 Minneapolis, MN 55440-9947

POSTAGE WILL BE PAID BY ADDRESSEE

BUSINESS REPLY MAIL
 FIRST CLASS MAIL PERMIT NO. 94 MINNEAPOLIS, MN

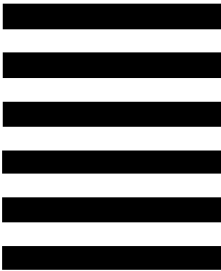

NO POSTAGE
 NECESSARY
 IF MAILED
 IN THE
 UNITED STATES

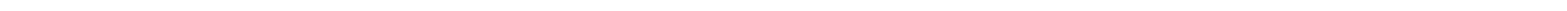
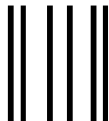

Fold along dotted lines

Tape here

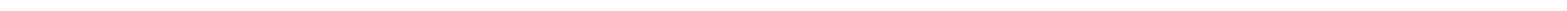



We Need Your Help...

As part of Tennant's Zero Defects Program, we want to know about errors you have found or suggestions you may have regarding our machine manuals. If you find an error or have a suggestion, please complete this postage-paid form and mail it to us. Thank you for helping us make zero defects a way of life at Tennant.

Manual No. _____ Rev. No. _____ Publish Date _____ Page _____
Machine _____ Report Error Suggestion

Name _____ Date _____
Customer Number _____
Company _____
Address _____
City/State/Zip Code _____



TENNANT COMPANY
 Technical Publications #15
 701 North Lilac Drive
 P.O. Box 1452
 Minneapolis, MN 55440-9947

POSTAGE WILL BE PAID BY ADDRESSEE

BUSINESS REPLY MAIL
 FIRST CLASS MAIL PERMIT NO. 94 MINNEAPOLIS, MN



NO POSTAGE
 NECESSARY
 IF MAILED
 IN THE
 UNITED STATES

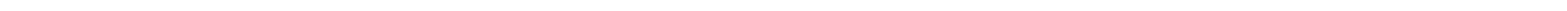
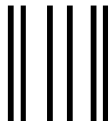

Fold along dotted lines

Tape here

