

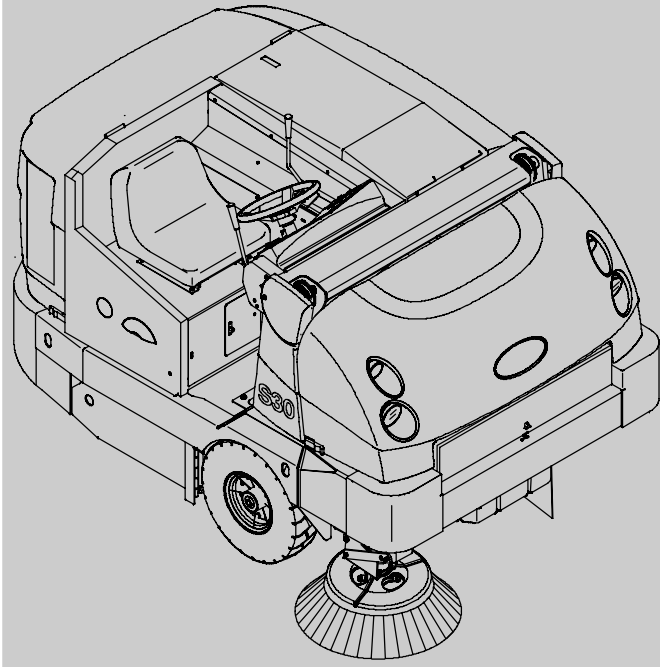

S30

Sweeper Service Information Manual



North America / International

www.tennantco.com

9004086
Rev. 00 (04-2008)



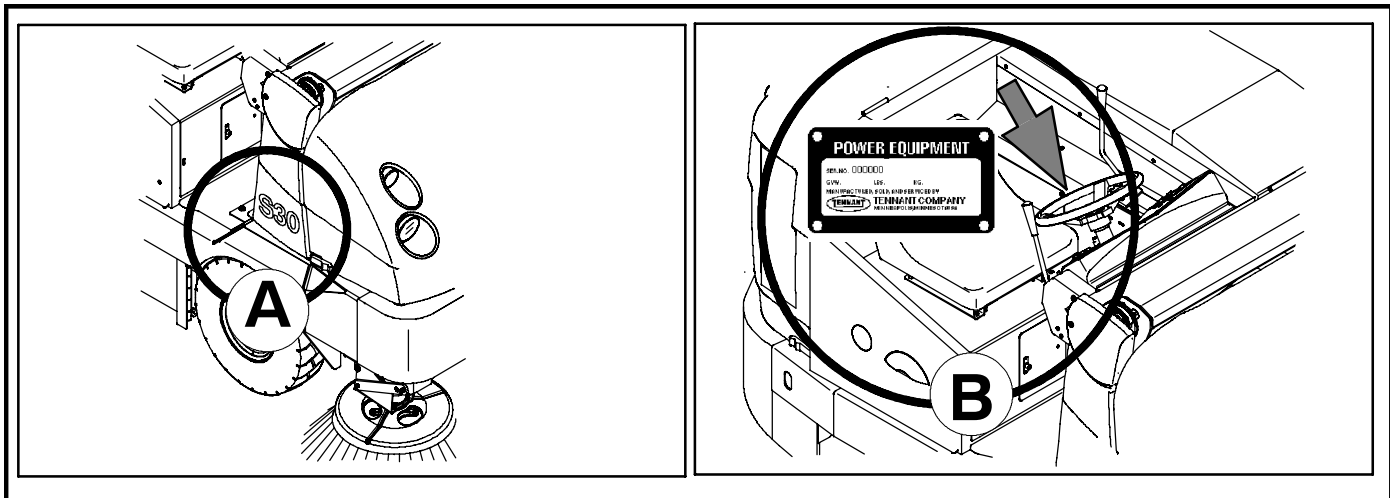

FOR REPLACEMENT PARTS

Identify machine model and serial number.

1. **(A)** Identify the machine model.
2. **(B)** Identify the machine serial number from the data plate.

Refer to the TENNANT Parts Manual.

NOTE: Only use TENNANT Company supplied or equivalent parts. Parts and supplies may be ordered online, by phone, by fax or by mail.

Tennant Company

PO Box 1452

Minneapolis, MN 55440

Phone: (800) 553-8033 or (763) 513-2850

www.tennantco.com

Thermo-Sentry, Touch-N-Go, 1-STEP, Clean-Wedge, Variable Drain Valve, EasyOpen, Grip-N-Go, MaxPro², Dura-Track, SmartRelease, InstantAccess, Duramer, FaST-PAK and ErgoSpace are US registered and unregistered trademarks of Tennant Company.

Specifications and parts are subject to change without notice.

Copyright © 2008 TENNANT Company, Printed in U.S.A.

SAFETY PRECAUTIONS	vi
GENERAL MACHINE INFORMATION	1
GENERAL MACHINE DIMENSIONS/CAPACITIES	2
GENERAL MACHINE PERFORMANCE	2
HYDRAULIC SYSTEM	2
STEERING	2
POWER TYPE	3
BRAKING SYSTEM	4
TIRES	4
MACHINE DIMENSIONS	4
COMPONENT LOCATOR (1 OF 6)	5
MAINTENANCE & REPAIR	11
MAINTENANCE CHECK POINTS	12
MAINTENANCE CHART (1 OF 2)	13
LUBRICATION	15
ENGINE OIL	15
REAR WHEEL SUPPORT (S30 and S30XP)	15
STEERING CYLINDER BEARING(S30 and S30XP)	15
HOPPER LIFT ARM BEARINGS	15
STEERING ROD END (S30X4)	16
STEERING SPINDLES (S30X4)	16
FRONT WHEEL BEARINGS	16
HYDRAULICS	17
HYDRAULIC FLUID	17
HYDRAULIC HOSES	18
ENGINE	18
COOLING SYSTEM	18
AIR FILTER	20
FUEL FILTER (Gasoline)	20
FUEL FILTER (LPG)	21
FUEL FILTER (Diesel)	21
FUEL LINES (Diesel)	21
PRIMING THE FUEL SYSTEM (Diesel)	22
ELECTRONIC PRESSURE REGULATOR (LPG)	22
ENGINE BELT	22
TIMING BELT (Gasoline/LPG)	22
SPARK PLUGS (Gasoline/LPG)	23
BATTERY	23
FUSES AND RELAYS	23
RELAY PANEL FUSES AND RELAYS	23
ENGINE HARNESS FUSES AND RELAYS (Gasoline/LPG) ...	24
ENGINE HARNESS RELAYS (Diesel)	25
CAB FUSES (CAB OPTION)	25
REMOVING AND INSPECTING THE DUST FILTER	26
CLEANING THE DUST FILTER	27
MAIN BRUSH	27
REPLACING OR ROTATING THE MAIN BRUSH	28
CHECKING THE MAIN BRUSH PATTERN	29
ADJUSTING THE MAIN BRUSH TAPER	29
ADJUSTING THE MAIN BRUSH WIDTH	30

MAINTENANCE & REPAIR	cont'd
SIDE BRUSH	30
REPLACING THE SIDE BRUSH	30
ADJUSTING THE SIDE BRUSH PATTERN	31
ROTATING AND REPLACING THE SIDE BRUSH GUARD	31
SKIRTS AND FLAPS	32
HOPPER SKIRTS	32
BRUSH DOOR SKIRTS	32
REAR SKIRT	32
RECIRCULATION FLAP	32
SEALS	33
BRUSH DOOR SEALS	33
DUST FILTER SEALS	33
HOPPER SEALS	33
HOPPER INSPECTION DOOR SEALS	33
FILTER CHAMBER INLET SEAL	34
DUST RETURN SEALS	34
VACUUM WAND DOOR SEALS (OPTION)	34
CYCLONIC PRE-FILTER SEALS	34
BRAKES AND TIRES	35
BRAKES	35
PARKING BRAKE	35
TIRES	35
REAR WHEEL	35
PROPELLING MOTOR	35
PUSHING, TOWING, AND TRANSPORTING THE MACHINE	36
PUSHING OR TOWING THE MACHINE	36
TRANSPORTING THE MACHINE	36
MACHINE JACKING	38
STORAGE INFORMATION	38
 ELECTRICAL	 39
ELECTRICAL SYMBOLS & ABBREVIATIONS	40
FUSES AND RELAYS (S30,S30XP,S30X4)	41
RELAY PANEL FUSES AND RELAYS	41
ENGINE HARNESS FUSES AND RELAYS	42
CAB FUSES (CAB OPTION)	42
S30 ELECTRICAL SCHEMATIC (1 OF 4)	43
S30XP / S30X4 ELECTRICAL SCHEMATIC (1 OF 4)	47
GASOLINE ENGINE HARNESS ELECTRICAL SCHEMATIC (1 OF 2)	51
LPG ENGINE HARNESS ELECTRICAL SCHEMATIC (1 OF 2)	53
DIESEL ENGINE HARNESS ELECTRICAL SCHEMATIC	55
CAB HARNESS ELECTRICAL SCHEMATIC	56
S30 WIRE HARNESS DRAWING (1 OF 2)	57
S30XP / S30X4 WIRE HARNESS DRAWING (1 OF 3)	59
ALL MACHINES HOPPER COVER WIRE HARNESS DRAWING	62
ALL MACHINES HOPPER WIRE HARNESS DRAWING	63
DIESEL ENGINE WIRE HARNESS DRAWING	64
CAB WIRE HARNESS DRAWING	65
KEY SWITCH INFORMATION (S30,S30XP,S30X4)	66
KEY OFF POWER DISTRIBUTION (S30)	67
KEY OFF POWER DISTRIBUTION (S30XP,S30X4)	68

ELECTRICAL	cont'd
KEY ON POWER DISTRIBUTION (S30)	69
KEY ON POWER DISTRIBUTION (S30XP,S30X4)	70
MAIN & SIDE BRUSHES ON (S30)	71
MAIN & SIDE BRUSHES ON (S30XP,S30X4)	72
VACUUM FAN ON (S30)	73
VACUUM FAN ON (S30XP,S30X4)	74
FILTER SHAKER ON (S30)	75
FILTER SHAKER ON (S30XP,S30X4)	76
HOPPER LIFT (S30)	77
HOPPER LIFT (S30XP,S30X4)	78
HOPPER LOWER (S30)	79
HOPPER LOWER (S30XP,S30X4)	80
HOPPER DOOR OPEN - AUTOMATIC (S30)	81
HOPPER DOOR OPEN - MANUAL (S30)	82
HOPPER DOOR OPEN (S30XP,S30X4)	83
HOPPER DOOR CLOSE - AUTOMATIC (S30)	84
HOPPER DOOR CLOSE (S30XP,S30X4)	85
DISPLAY MODULE FAULT INDICATORS (S30)	86
FAULT INDICATORS (S30XP,S30X4)	87
DASH FAULT INDICATORS (S30,S30XP,S30X4)	88
OPERATING, MAINT., & DIAG. MODES (S30XP,S30X4) (1 OF 2) .	89
CIRCUIT BOARD PIN FUNCTIONS (S30XP,S30X4)	91
 HYDRAULIC	 93
GENERAL INFORMATION (S30, S30XP, S30X4) (1 OF 2)	94
HYDRAULIC SCHEMATIC (S30, S30XP) (1 OF 2)	96
HYDRAULIC SCHEMATIC (S30X4) (1 OF 2)	98
OVERALL HYDRAULIC HOSE DIAGRAM (S30)	100
OVERALL HYDRAULIC HOSE DIAGRAM (S30XP)	101
OVERALL HYDRAULIC HOSE DIAGRAM (S30X4)	102
RESERVOIR HOSE DIAGRAM	103
COOLER HOSE & TUBE DIAGRAM	104
PUMPS DIAGRAM (S30, S30XP)	105
PUMPS DIAGRAM (S30X4)	106
VALVE BLOCK DIAGRAM (S30)	107
VALVE BLOCK DIAGRAM (S30XP, S30X4)	108
PRIORITY AND FLOW DIVIDER VALVE DIAGRAM (S30X4)	109
LEFT SIDE BRUSH HYDRAULIC DIAGRAM (S30XP, S30X4)	110
MAIN BRUSH ON (S30, S30XP, S30X4)	111
MAIN BRUSH & SIDE BRUSH(ES) ON (S30, S30XP, S30X4)	112
HOPPER DOOR OPEN (S30, S30XP, S30X4)	113
HOPPER DOOR CLOSE (S30, S30XP, S30X4)	114
HOPPER LIFT (S30, S30XP, S30X4)	115
HOPPER LOWER (S30, S30XP, S30X4)	116
VACUUM FAN ON (S30, S30XP, S30X4)	117
MAIN BRUSH LOWER (S30XP, S30X4)	118
MAIN BRUSH & SIDE BRUSH(ES) LOWER (S30XP, S30X4)	119
3-WHEEL STEERING SYSTEM (S30, S30XP)	120
4-WHEEL STEERING SYSTEM (S30X4)	121
3-WHEEL PROPEL SYSTEM (S30, S30XP)	122
4-WHEEL PROPEL SYSTEM (S30X4)	123

SAFETY PRECAUTIONS

The following precautions are used throughout this manual as indicated in their description:

 **WARNING:** To warn of hazards or unsafe practices that could result in severe personal injury or death.

 **CAUTION:** To warn of unsafe practices that could result in minor or moderate personal injury.

FOR SAFETY: To identify actions that must be followed for safe operation of equipment.

Do not use the machine other than described in this Operator Manual. The machine is not designed for use on public roads.

The following information signals potentially dangerous conditions to the operator or equipment:

 **WARNING:** Flammable materials or reactive metals can cause an explosion or fire. Do not pickup.

 **WARNING:** Moving belt and fan. Keep away.

 **WARNING:** Engine emits toxic gases. Serious injury or death can result. Provide adequate ventilation.

 **WARNING:** Raised hopper may fall. Engage hopper support pin.

 **WARNING:** Lift arm pinch point. Stay clear of hopper lift arms.

 **WARNING:** Burn hazard. Hot surface. Do NOT touch.

 **WARNING:** Machine can emit excessive noise. Hearing loss can result. Wear hearing protection.

 **CAUTION:** LPG engine will run for a few seconds after key is turned off. Apply parking brake before leaving machine.

 **WARNING:** Accident may occur. Do not operate vacuum or blower wand while driving.

CALIFORNIA PROPOSITION 65 WARNING: Engine exhaust from this product contains chemicals known to the State of California to cause cancer, birth defects, or other reproductive harm.

FOR SAFETY:

1. Do not operate machine:
 - Unless trained and authorized.
 - Unless operator manual is read and understood.
 - If it is not in proper operating condition.
 - In flammable or explosive areas.
 - In areas with possible falling objects unless equipped with overhead guard.
2. Before starting machine:
 - Check for fuel, oil, and liquid leaks.
 - Keep sparks and open flame away from refueling area.
 - Make sure all safety devices are in place and operate properly.
 - Check brakes and steering for proper operation.
3. When starting machine:
 - Keep foot on brake and directional pedal in neutral.
4. When using machine:
 - Always wear safety belt (if so equipped)
 - Do not pick up burning or smoking debris, such as cigarettes, matches or hot ashes
 - Use brakes to stop machine.
 - Go slow on inclines and slippery surfaces.
 - Use care when reversing machine.
 - Move machine with care when hopper is raised.
 - Make sure adequate clearance is available before raising hopper.
 - Do not carry passengers on machine.
 - Always follow safety and traffic rules.
 - Report machine damage or faulty operation immediately.

5. **Before leaving or servicing machine:**
 - Stop on level surface.
 - Set parking brake.
 - Turn off machine and remove key.

6. **When servicing machine:**
 - Avoid moving parts. Do not wear loose jackets, shirts, or sleeves.
 - Block machine tires before jacking machine up.
 - Jack machine up at designated locations only. Support machine with jack stands.
 - Use hoist or jack that will support the weight of the machine.
 - Wear eye and ear protection when using pressurized air or water.
 - Disconnect battery connections before working on machine.
 - Avoid contact with battery acid.
 - Avoid contact with hot engine coolant.
 - Do not remove cap from radiator when engine is hot.
 - Allow engine to cool.
 - Keep flames and sparks away from fuel system service area. Keep area well ventilated.
 - Use cardboard to locate leaking hydraulic fluid under pressure.
 - Use Tennant supplied or approved replacement parts.

7. **When loading/unloading machine onto/off truck or trailer:**
 - Turn off machine.
 - Use truck or trailer that will support the weight of the machine.
 - Use winch. Do not drive the machine onto/off the truck or trailer unless the load height is 380 mm (15 in) or less from the ground.
 - Set parking brake after machine is loaded.
 - Block machine tires.
 - Tie machine down to truck or trailer.

GENERAL MACHINE INFORMATION

G

BEFORE CONDUCTING TESTS:

- * Read and Follow ALL Safety Warnings and Precautions as mentioned at the beginning of this manual
- * Always unhook Battery when removing or replacing components

DURING TESTS:

- * Call Technical Services if Diagnostic Time Exceeds One Hour With Unknown Cause or Course of Action

NOTE: Troubleshooting charts may be shown with optional equipment. The optional equipment may not be specified in these charts. Some machines may not be equipped with all components shown.

SPECIFICATIONS

GENERAL MACHINE DIMENSIONS/CAPACITIES

Item	Dimension/capacity
Length	2360 mm (93 in)
Height	1475 mm (58 in)
Height (with overhead guard)	2095 mm (82.5 in)
Width/frame	1590 mm (62.5 in)
Cleaning path width (Single side brush)	1590 mm (62.5 in)
Cleaning path width (Dual side brushes)	2030 mm (80 in)
Main brush diameter	356 mm (14 in)
Side brush diameter	660 mm (26 in)
Debris hopper volume capacity (Plastic and Steel)	395 L (14 ft ³)
Debris hopper weight capacity (Plastic)	490 kg (1080 lbs)
Debris hopper weight capacity (Steel)	545 kg (1200 lbs)
Dump height (variable to)	1525 mm (60 in)
Minimum ceiling dump height	2500 mm (98 in)
Weight - empty	1595 Kg (3520 lbs)
GVWR	2585 Kg (5700 lbs)
Transport ground clearance	100 mm (4 in)
Operating Sound Level At Operator Ear	80 ±1.5 dBA
Vibration level at steering wheel does not exceed	0.2 m/s ²

GENERAL MACHINE PERFORMANCE

Item	Measure
Minimum aisle turn	2870 mm (113 in)
Travel speed forward (maximum) (S30 and S30XP)	16.0 Km/h (10 mph)
Travel speed forward (maximum) (S30X4)	24.0 Km/h (15 mph)
Travel speed reverse (maximum)	5.0 Km/h (3 mph)
Maximum rated climb and descent (full hopper)	10°/18%
Maximum rated climb and descent (empty hopper)	14°/25%

HYDRAULIC SYSTEM

System	Capacity	Fluid Type
Hydraulic reservoir	38 L (10 gal)	TENNANT part no. 65869 - above 7° C (45° F)
Hydraulic total	45 L (12 gal)	TENNANT part no. 65870 - below 7° C (45° F)

STEERING

Type	Power source
Rear wheel, hydraulic cylinder	Hydraulic accessory pump

POWER TYPE

Engine	Type	Ignition	Cycle	Aspiration	Cylinders	Bore	Stroke
GM 1.6	Piston	Distributorless-type spark	4	Natural	4	79 mm (3.11 in)	81.5 mm (3.21 in)
	Displacement		Net power, governed		Net power, maximum		
	1600 cc (98 cu in)		23.2 kw (32 hp) @ 2400 rpm		41 kw (55 hp) @ 4000 rpm		
	Fuel		Cooling system		Electrical system		
	Gasoline, 87 octane minimum, unleaded Fuel tank: 42 L (11.2 gal)		Water/ethylene glycol antifreeze		12 V nominal		
	LPG, Fuel tank: 15 kg (33 lb)		Total: 7.5 L (2 gal) Radiator: 3.8 L (1 gal)		75 A alternator		
	Idle speed, no load		(Fast) governed speed, under load		Firing order		
	1350 ± 50 rpm		Normal sweep mode: 2000 ± 50 rpm Litter sweep mode: 2400 ± 50 rpm		1-3-4-2		
	Spark plug gap		Valve clearance, cold		Engine lubricating oil with filter		
	1 mm (0.035 in)		No Adjustment OHC Engine		3.5 L (3.7 qt) 5W30 SAE-SG/SH		
Engine	Type	Ignition	Cycle	Aspiration	Cylinders	Bore	Stroke
Kubota V1505-B	Piston	Diesel	4	Natural	4	78 mm (3.07 in)	78.4 mm (3.08 in)
	Displacement		Net power, governed		Net power, maximum		
	1500 cc (91.4 cu in)		24.6 kw (34 hp) @ 2400 rpm		27.2 kw (37.5 hp) @ 3000 rpm		
	Fuel		Cooling system		Electrical system		
	Diesel Fuel tank: 42 L (11.2 gal)		Water/ethylene glycol antifreeze		12 V nominal		
			Total: 7.5 L (2 gal) Radiator: 3.8 L (1 gal)		75 A alternator		
	Idle speed, no load		(Fast) governed speed, under load		Engine lubricating oil without filter		
	1350 ± 50 rpm		2000 ± 50 rpm 2400 ± 50 rpm		6 L (6.35 qt) Diesel rated engine oil above CD grade only		



BRAKING SYSTEM

Type	Operation
Service brakes	Mechanical drum brakes (2), one per front wheel, cable actuated
Parking brake	Utilize service brakes, cable actuated

TIRES

Location	Type	Size
Front (2)	Solid	127 mm x 535 mm (5 in x 21 in)
Rear (1) (S30 and S30XP)	Pneumatic	115 mm x 470 mm (4.5 in x 18.5 in)
Rear (2) (S30X4)	Foam Fill	115 mm x 410 mm (4.5 in x 16 in)

MACHINE DIMENSIONS

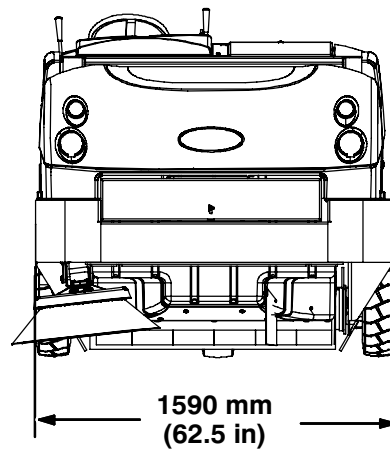
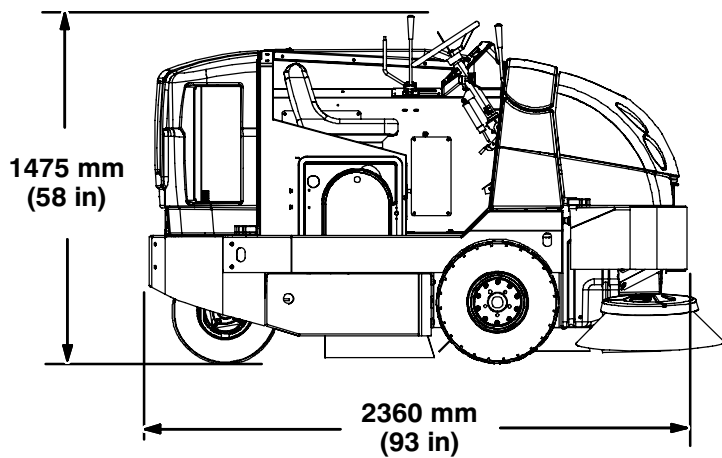
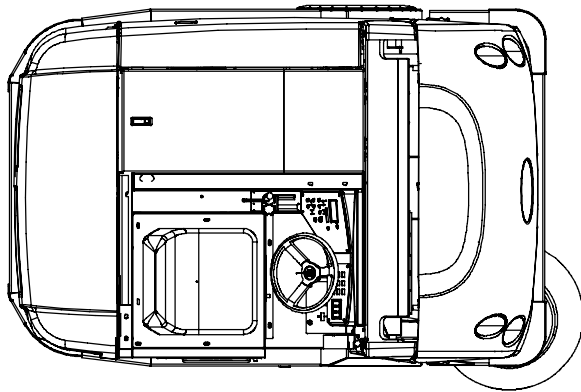

354726

Component Locator

(page 1 of 6)

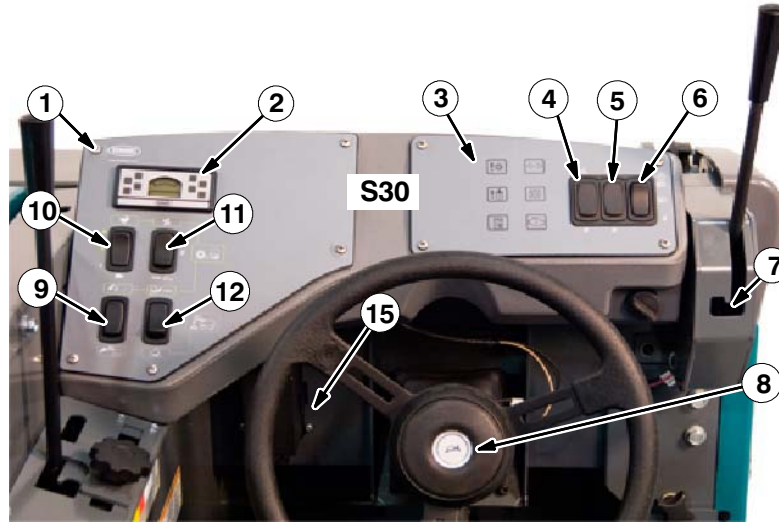

1. Instrument panel
2. Indicator panel
3. Dash Fault Indicator lights (LP8,LP9,LP10,LP11,LP12)
4. Wand switch (option) (SW21)
5. Side brush light switch (option) (SW17)
6. Operating / hazard light switch (SW12)
7. Side Brush Lever Switch (SW7)
8. Horn button (SW19)
9. Hopper raise / lower switch (SW22)
10. Engine speed switch (SW6)
11. Vacuum fan / filter shaker switch (SW18)
12. Hopper door switch (SW3)
13. Sweeping function buttons (see next page)
14. Supervisor control buttons (see next page)
15. Fuse & relay panel

Component Locator

(page 2 of 6)

G



1. Supervisor control buttons
2. Hour meter / fuel indicator / fault code indicator
3. Contrast control button
4. 1-STEP sweep button
5. Engine speed button
6. Vacuum fan button
7. Side brush button
8. Hopper door open button
9. Hopper door close button
10. Hopper lower button
11. Hopper raise button
12. Filter shaker button
13. Fault indicator light

Component Locator

(page 3 of 6)

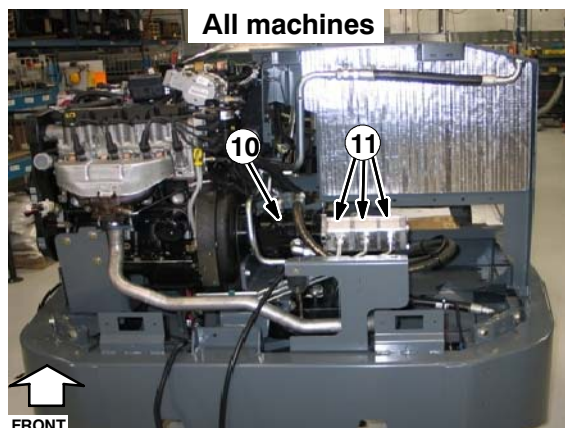
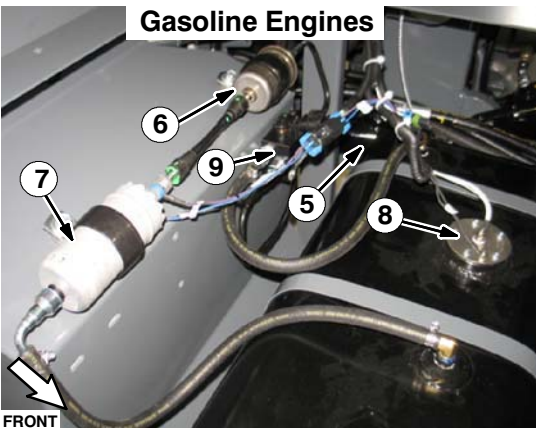
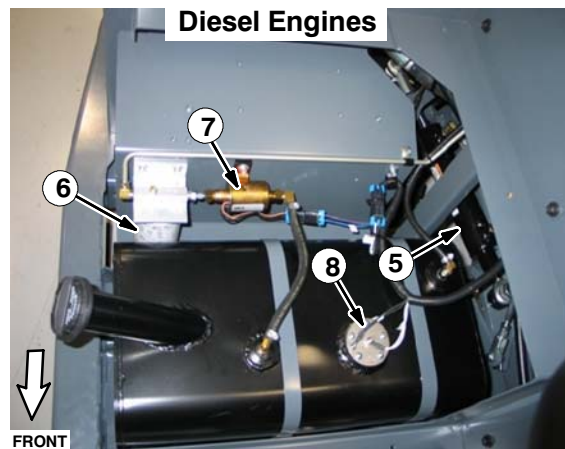
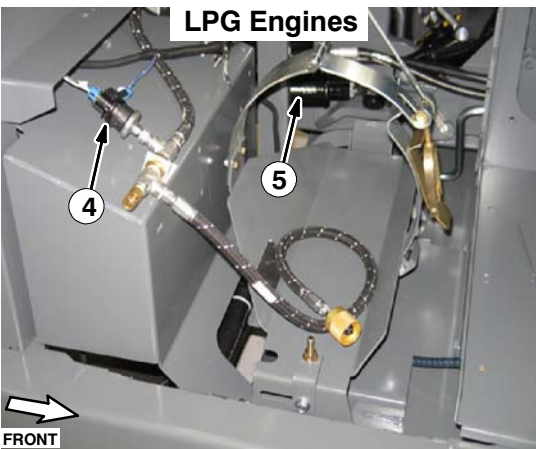
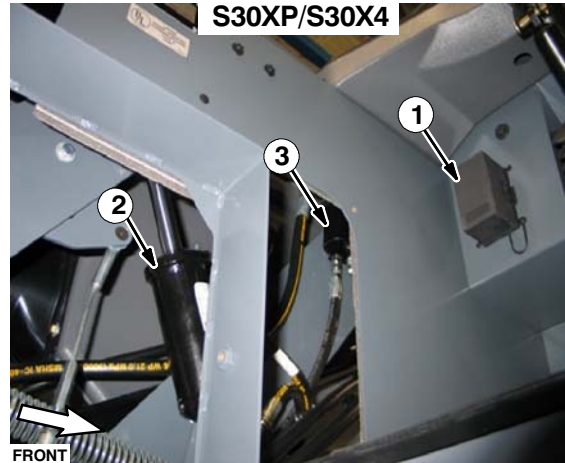
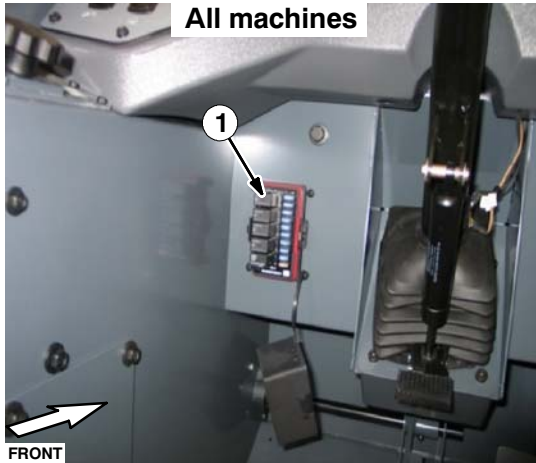

- | | |
|---|---|
| <ul style="list-style-type: none"> 1. Fuse & relay panel 2. Main Brush Lift Cylinder (CYL4) 3. Steering Priority Valve (S30X4 Only) 4. Low Fuel Pressure Switch (SW2 or S3) 5. Steering Cylinder (S30/S30XP Only - CYL5) 6. Fuel Filter | <ul style="list-style-type: none"> 7. Fuel Pump (PUMP1) 8. Fuel Sending Unit (SNDR1 or S2) 9. Fuel Pressure Regulator 10. Propel System Hydraulic Pump (PUMP1) 11. Accessory Hydraulic Pumps (PUMP2, 3, & 4) |
|---|---|



Component Locator

(page 4 of 6)

G

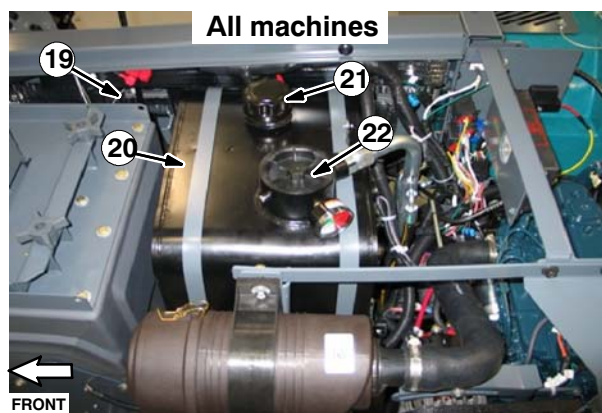
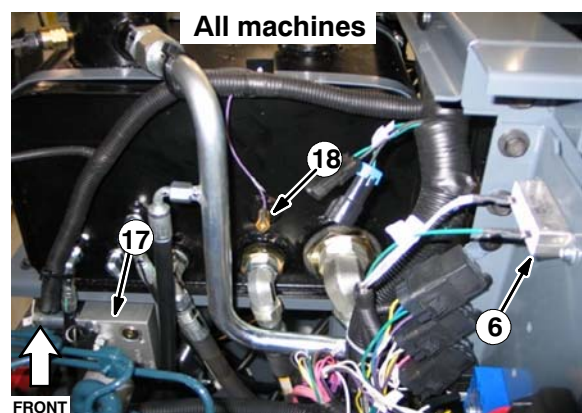
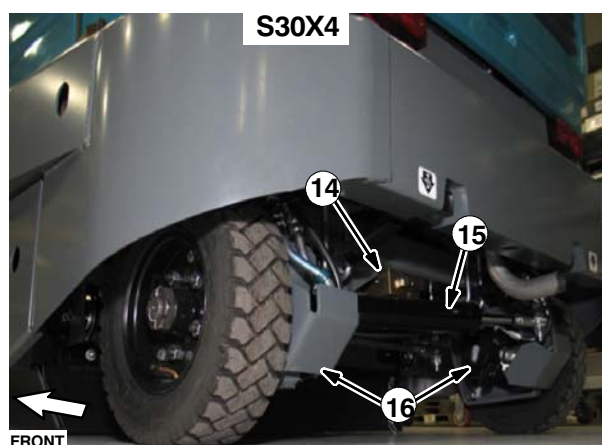
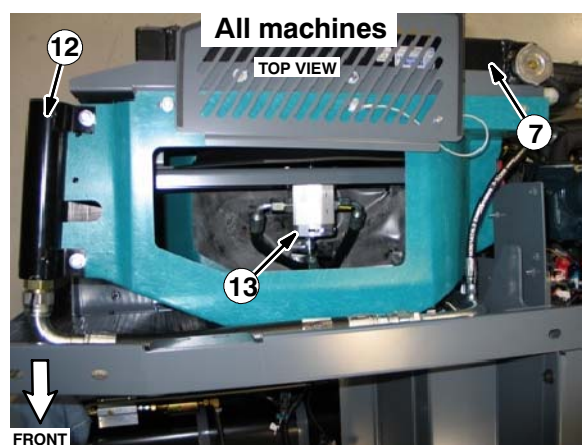
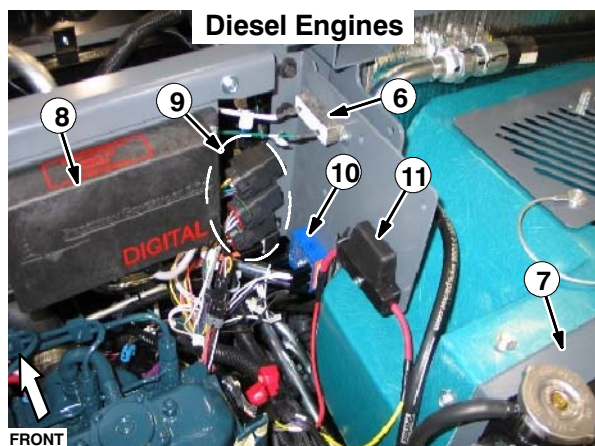
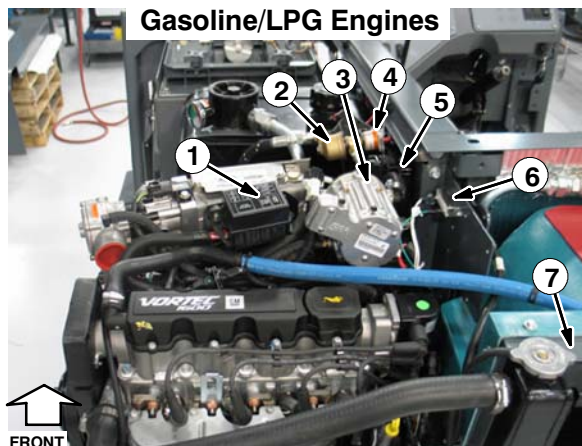

- 1. Engine Fuse & Relay Panel
- 2. Fuel Filter (LPG Only)
- 3. Electronic Fuel Pressure Regulator (LPG Only)
- 4. Fuel Lockoff Valve (LPG Only)
- 5. Engine Control Module
- 6. Alternator Pull-Up Resistor (R1)
- 7. Engine Radiator

- 12. Hydraulic Oil Cooler (HTX)
- 13. Engine Fan Motor (MTR6)
- 14. Propel System Flow Divider Valve
- 15. Steering Cylinder (CYL5)
- 16. Left & Right Propel Motors (MTR6 & MTR7)
- 17. Hydraulic Valve Manifold
- 18. Hydraulic Oil Temp. Sender (SNDR3 or S7)
- 19. Main Brush Lever Switch (S30 Only - SW5)
- 20. Hydraulic Oil Reservoir (RES1)
- 21. Reservoir Cap & Oil Level Indicator
- 22. Hydraulic Oil Filter (FLTR)

Component Locator

(page 5 of 6)

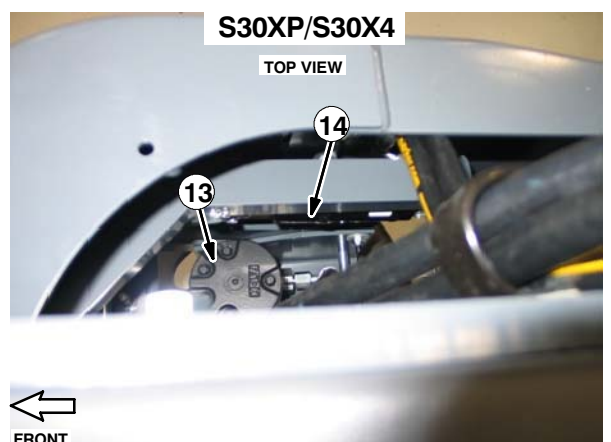
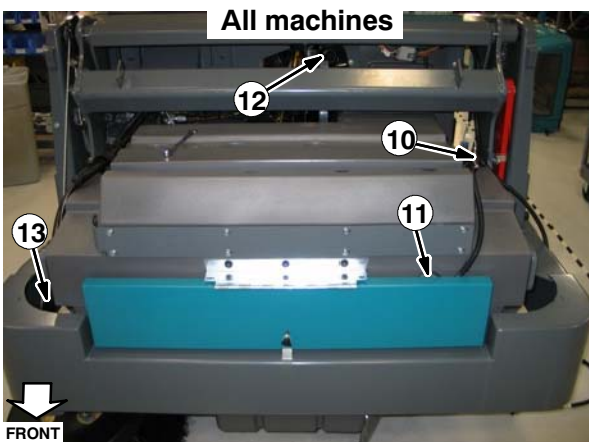
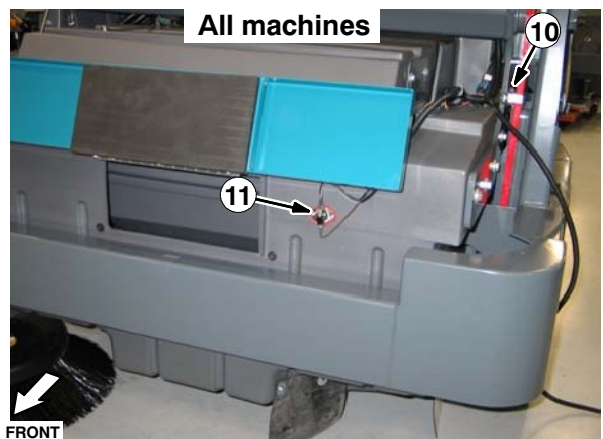
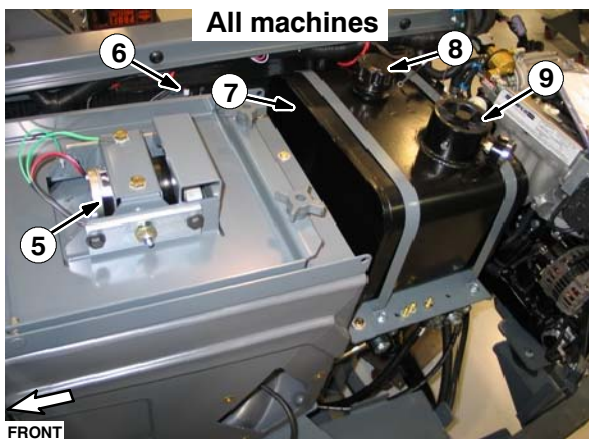
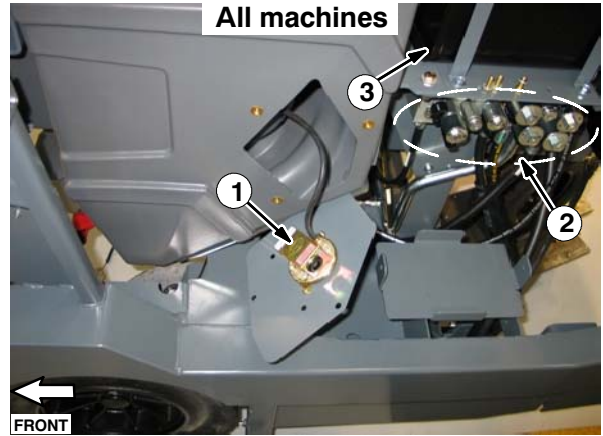
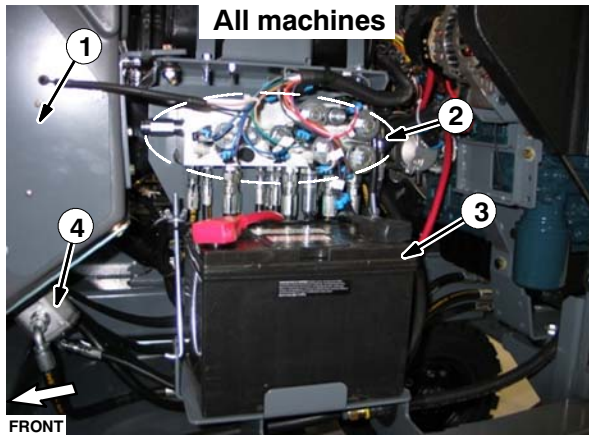

- 1. Clogged Dust Filter Switch (SW8 or S8)
- 2. Hydraulic Valve Manifold
- 3. Battery
- 4. Vacuum Fan Motor (MTR5)
- 5. Dust Filter Shaker Motor (MTR1)
- 6. Main Brush Lever Switch (S30 Only - SW5)
- 7. Hydraulic Oil Reservoir (RES1)

- 8. Reservoir Cap & Oil Level Indicator
- 9. Hydraulic Oil Filter (FLTR)
- 10. Hopper Position Switch (SW16)
- 11. Thermo-Sentry Switch (SW14)
- 12. Horn (LS1)
- 13. Side Brush Motor (MTR2)
- 14. Side Brush Lift Cylinder (CYL3)

Component Locator

(page 6 of 6)

G



1. Hopper Door Cylinder (CYL1)
2. Hopper Lift Cylinder (CYL2)
3. Horn (LS1)
4. Hopper Position Switch (SW16)
5. Brake Switch (S15)
6. Steering Valve

MAINTENANCE & REPAIR

M

BEFORE CONDUCTING TESTS:

- * Read and Follow ALL Safety Warnings and Precautions as mentioned at the beginning of this manual
- * Always unhook Battery when removing or replacing electrical components

DURING TESTS:

- * Call Technical Services if Diagnostic Time Exceeds One Hour With Unknown Cause or Course of Action

NOTE: Troubleshooting charts may be shown with optional equipment. The optional equipment may not be specified in these charts. Some machines may not be equipped with all components shown.

MAINTENANCE

M

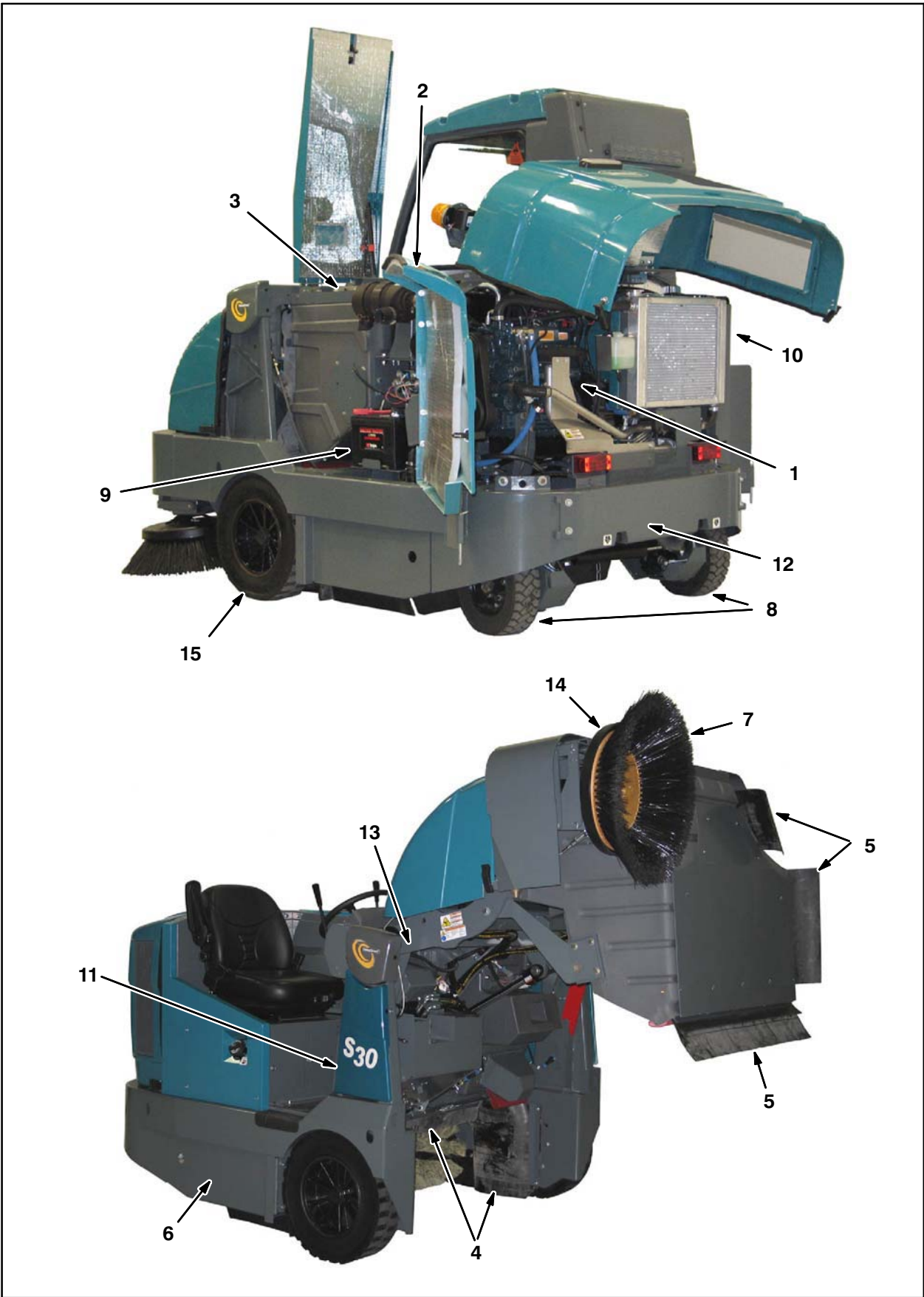

MAINTENANCE

MAINTENANCE CHART

Interval	Key	Description	Procedure	Lubricant/ Fluid	No. of Service Points
Daily	1	Engine	Check oil level	EO	1
			Check coolant level in reservoir	WG	1
			Check air filter indicator	–	1
	2	Hydraulic fluid reservoir	Check fluid level	HYDO	1
	3	Dust filter	Shake to clean	–	1
	4	Main brush compartment skirts	Check for damage, wear, and adjustment	–	All
	5	Hopper skirts	Check for damage, wear, and adjustment	–	All
	6	Main brush	Check for damage and wear	–	1
50 Hours	7	Side brush	Check for damage and wear	–	1
	6	Main brush	Rotate end-for-end and check pattern	–	1
	8	Rear wheel	Torque wheel nuts (after initial 50 hours only)	–	1
	9	Battery	Clean and tighten battery cable connections (after initial 50 hours only)	–	1
100 Hours	1	Engine	Check belt tension	–	1
			Change oil and filter	EO	1
			Drain oil from electronic pressure regulator (EPR)	–	1
	3	Dust filter	Check for damage, clean or replace	–	1
	10	Radiator	Clean core exterior	–	1
	10	Hydraulic cooler	Clean core exterior	HYDO	1
	8	Rear tire	Check pressure	–	1
	–	Seals	Check for damage or wear	–	All
200 Hours	10	Radiator hoses and clamps	Check for tightness and wear	–	All
	11	Parking brake	Check adjustment	–	1
	11	Brake pedal	Check adjustment	–	1
	12	Rear wheel support bearings	Lubricate	SPL	2
	12	Steering cylinder bearings	Lubricate	SPL	1
	13	Hopper lift arm bearings	Lubricate	SPL	2
	14	Side brush guard	Rotate 90°	–	1

MAINTENANCE

Interval	Key	Description	Procedure	Lubricant/ Fluid	No. of Service Points
400 Hours	1	Engine	Clean and re-gap or replace spark plugs	–	4
			Replace fuel filter (Gas/LPG)	–	1
	15	Front wheels	Adjust and repack bearings	SPL	2
800 Hours	2	Hydraulic fluid reservoir	Replace filler cap	–	1
	1	Engine	Check timing belt	–	1
	–	Hydraulic hoses	Check for wear and damage	–	All
	10	Cooling system	Flush	WG	1
	8	Propelling motor	Torque shaft nut	–	1
	8	Rear wheel	Torque wheel nuts	–	1
	9	Battery	Clean and tighten battery cable connections	–	1
1200 Hours	2	Hydraulic fluid filter	* Change filter element	–	All
2000 Hours	1	Engine	Replace timing belt		1
2400 Hours	2	Hydraulic fluid reservoir	* Replace suction strainer	–	1
			* Change hydraulic fluid	HYDO	1

NOTE: Change the hydraulic fluid, filter, and suction strainer, indicated (), after every 800 hours for machines NOT originally equipped with **Tennant True** premium hydraulic fluid. (See Hydraulics section).*

LUBRICANT/FLUID

EO Engine oil, 5W30 SAE–SG/SH only.

HYDO . **Tennant True** premium hydraulic fluid or equivalent

WG . . . Water and ethylene glycol anti-freeze, –34° C (–30° F)

SPL . . . Special lubricant, Lubriplate EMB grease (Tennant part number 01433–1)

NOTE: More frequent maintenance intervals may be required in extremely dusty conditions.

LUBRICATION

ENGINE OIL

Check the engine oil level daily. Change the oil and oil filter after every 100 hours of operation.

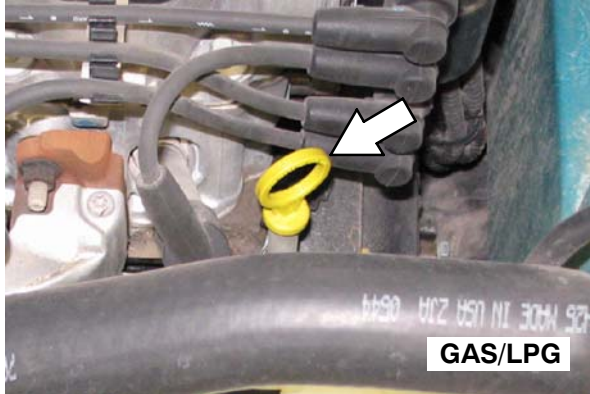

Gas/LPG engines: Fill the engine with oil until the oil is between the indicator marks on the dipstick. DO NOT fill past the top indicator mark. The engine oil capacity is 3.5 L (3.7 qt) with oil filter.

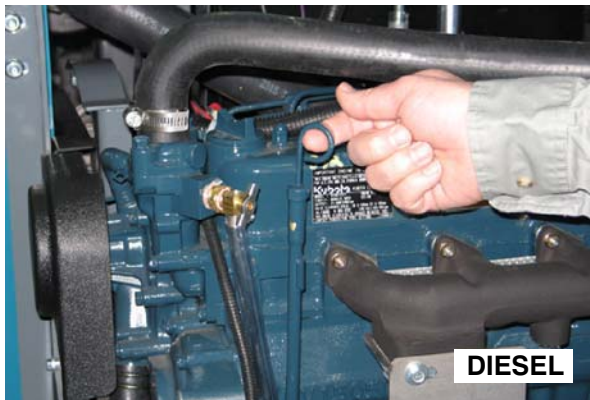

Diesel engines: Fill the engine with oil until the oil is between the indicator marks on the dipstick. DO NOT fill past the top indicator mark. The engine oil capacity is 6 L (6.35 qt) with oil filter.

REAR WHEEL SUPPORT (S30 and S30XP)

Lubricate the rear wheel support bearings after every 200 hours of operation.

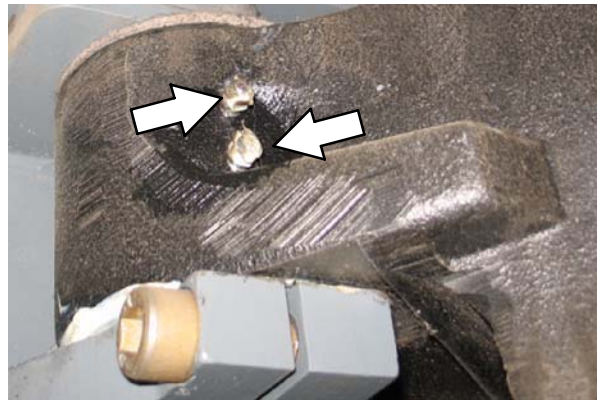

STEERING CYLINDER BEARING (S30 and S30XP)

Lubricate the steering cylinder after every 200 hours of operation.

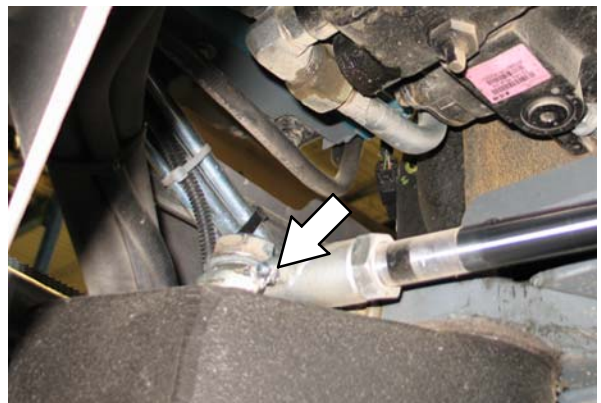

HOPPER LIFT ARM BEARINGS

Lubricate the hopper lift arm bearings after every 200 hours of operation.



STEERING ROD END (S30X4)

Lubricate the steering rod end and spindles after every 200 hours of operation.

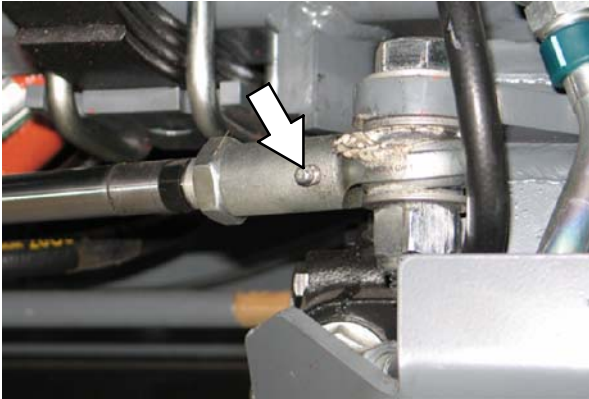

FRONT WHEEL BEARINGS

Repack and adjust the front wheel bearings every 400 hours of operation.



M

STEERING SPINDLES (S30X4)

Lubricate the steering after every 200 hours of operation.

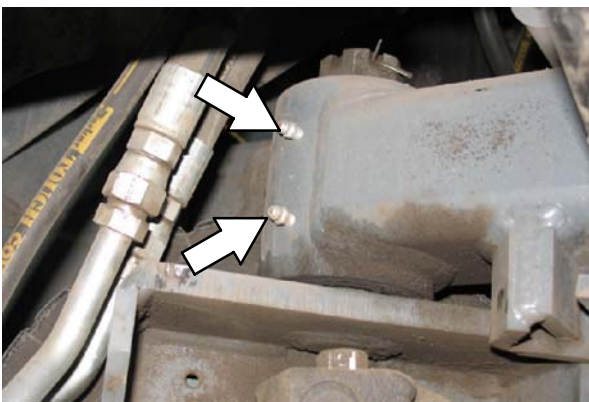
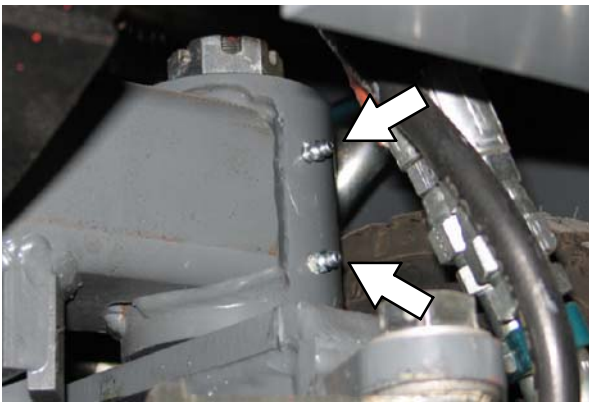

HYDRAULICS

Check the hydraulic fluid level at operating temperature daily. The hopper must be down when checking hydraulic fluid level.



A filler cap is mounted on top of the reservoir. It has a built-in breather and fluid level dipstick. Replace the cap after every 800 hours of operation.

Lubricate the filler cap gasket with a film of hydraulic fluid before putting the cap back on the reservoir.

ATTENTION! Do not overfill the hydraulic fluid reservoir or operate the machine with a low level of hydraulic fluid in the reservoir. Damage to the machine hydraulic system may result.

Drain and refill the hydraulic fluid reservoir with new **Tennant True** premium hydraulic fluid after every 2400 hours of operation. Machines have a blue colored drop (left photo) on the hydraulic fluid label if originally equipped with **Tennant True** premium hydraulic fluid.

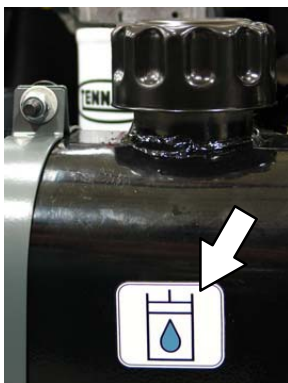

Tennant True Fluid

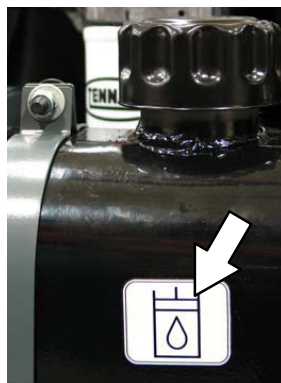

Previous Fluid

*NOTE: Change the hydraulic fluid, filter, and suction strainer after every 800 hours for ALL machines that have NOT consistently used **Tennant True** premium hydraulic fluid or equivalent.*

The reservoir has a built-in strainer outlet that filters hydraulic fluid before it enters the system. Replace the strainer after every 2400 hours of operation.

Replace the hydraulic fluid filter after every 1200 hours of operation or if the hydraulic reservoir gauge is in the yellow/red zone when the reservoir hydraulic fluid is approximately 32°C (90° F).



HYDRAULIC FLUID

There are two fluids available for different temperature ranges:

Tennant True premium hydraulic fluid (Extended Life)			
Part number	Ambient temperature	ISO Grade	Capacity
1057710	above 7° C (45° F)	100	3.8 L (1 gal)
1057711	above 7° C (45° F)	100	19 L (5 gal)
1057707	below 7° C (45° F)	32	3.8 L (1 gal)
1057708	below 7° C (45° F)	32	19 L (5 gal)

If using a locally-available hydraulic fluid, be sure the specifications match Tennant hydraulic fluid specifications. Substitute fluids can cause premature failure of hydraulic components.

ATTENTION! Hydraulic components depend on system hydraulic fluid for internal lubrication. Malfunctions, accelerated wear, and damage will result if dirt or other contaminants enter the hydraulic system.

HYDRAULIC HOSES

Check the hydraulic hoses after every 800 hours of operation for wear or damage.

FOR SAFETY: When servicing machine, use cardboard to locate leaking hydraulic fluid under pressure.

High pressure fluid escaping from a very small hole can almost be invisible, and can cause injury.

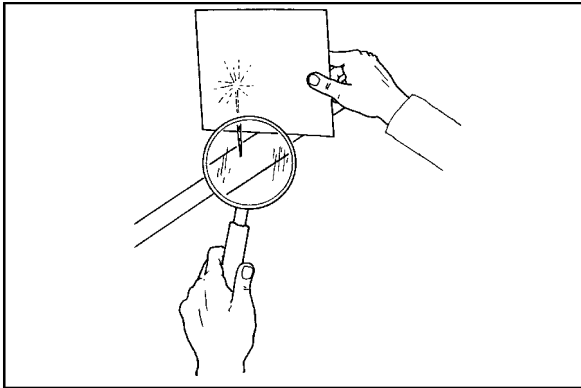

00002

Contact appropriate personnel if a leak is discovered.

ATTENTION: Only use TENNANT supplied hydraulic hoses or equivalent rated hydraulic hoses.

ENGINE**COOLING SYSTEM**

FOR SAFETY: When servicing machine, avoid contact with hot engine coolant.

Check the coolant level in the reservoir daily. The coolant level must be between the two indicator marks when the engine is cold.

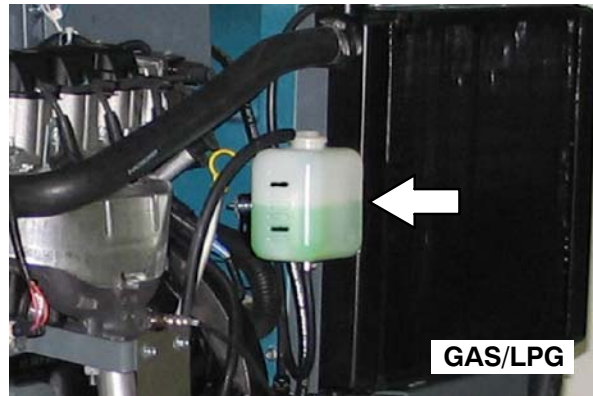

FOR SAFETY: When servicing machine, do not remove cap from radiator when engine is hot. Allow engine to cool.

Check the coolant level in the radiator after every 100 hours of operation. Refer to the label on the coolant container for water/coolant mixing instructions.

Flush the radiator and the cooling system after every 800 hours of operation.

M

The cooling system must be completely filled with coolant to keep the engine from overheating. When filling the cooling system, open the drain cocks to bleed the air from the system.

Check the radiator hoses and clamps after every 200 hours of operation. Tighten loose clamps. Replace damaged hoses and clamps.

Location of drain cock on LPG machines.

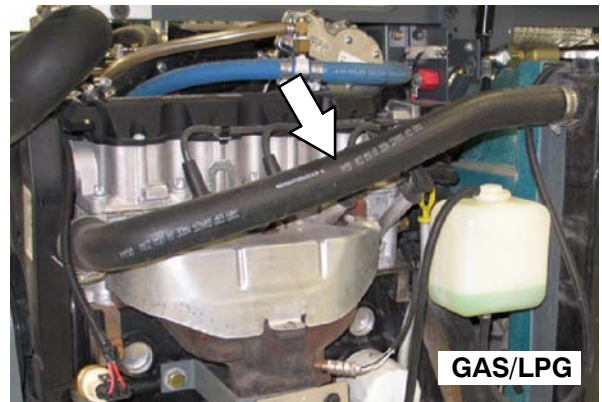
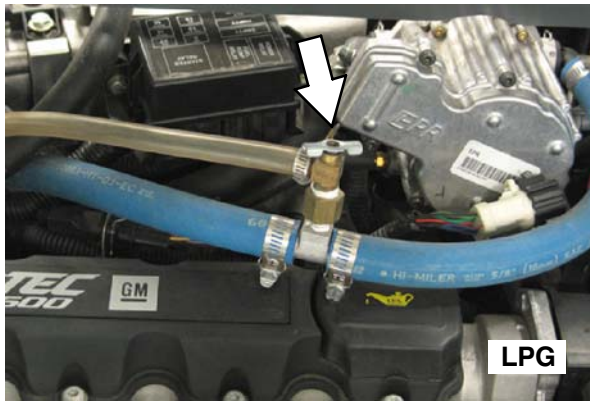

Location of drain cock on gasoline machines.

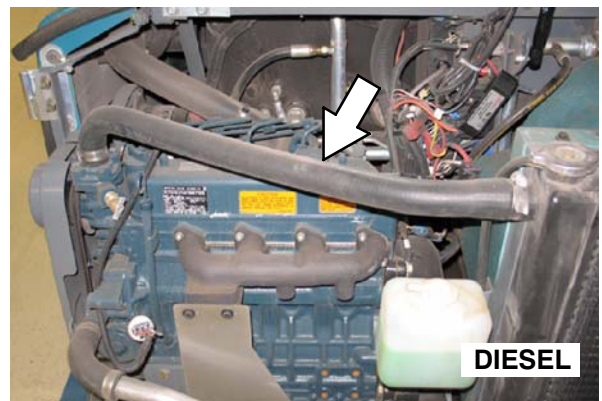
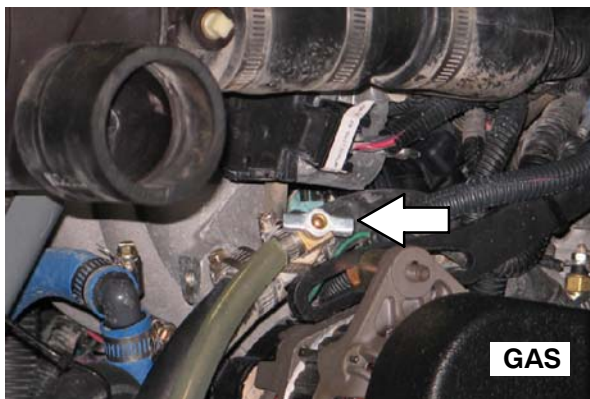

Location of drain cock on diesel machines.

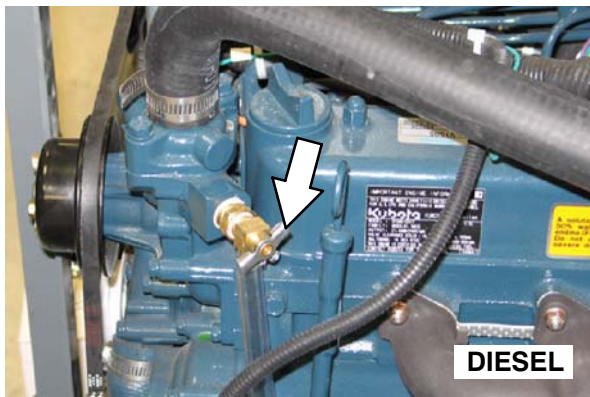

Check the radiator core exterior and hydraulic cooler fins for debris after every 100 hours of operation. Blow or rinse (with low pressure air or water) all dust through the grille and radiator fins, in the opposite direction of normal air flow. Be careful to not bend the cooling fins when cleaning. Clean thoroughly to prevent the fins from becoming encrusted with dust. To avoid cracking the radiator, allow the radiator and cooler fins to cool before cleaning.

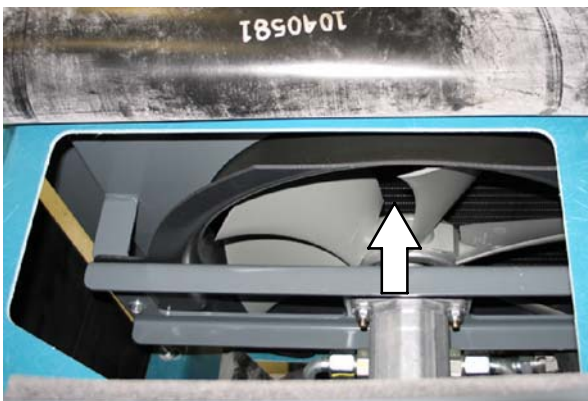
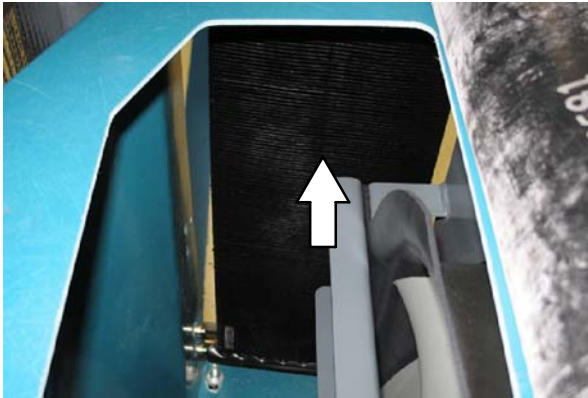

FOR SAFETY: When servicing machine, wear eye and ear protection when using pressurized air or water.

AIR FILTER

Replace the primary air filter after every 400 hours of operation.

NOTE: Clean the filter more often if machine is used in extremely dusty conditions.

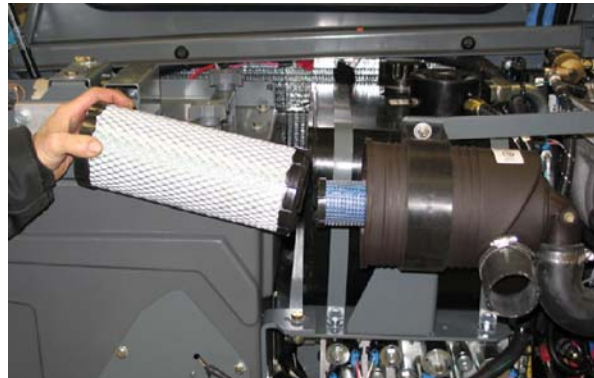

Replace the safety filter element after the primary has been changed three times. Do not remove the safety filter element from the housing unless it is restricting air flow.

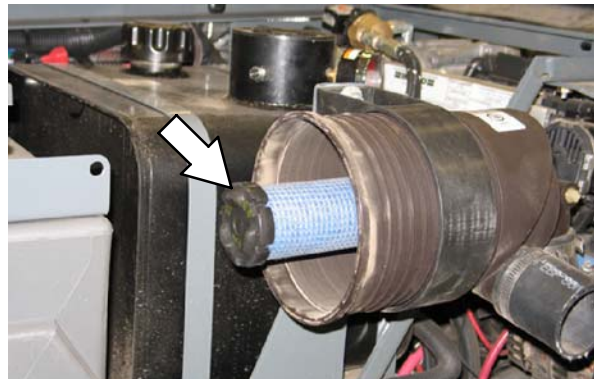

FUEL FILTER (Gasoline)

Replace the gasoline fuel filter after every 800 hours of operation.

FOR SAFETY: When servicing machine, keep flames and sparks away from fuel system service area. Keep area well ventilated.

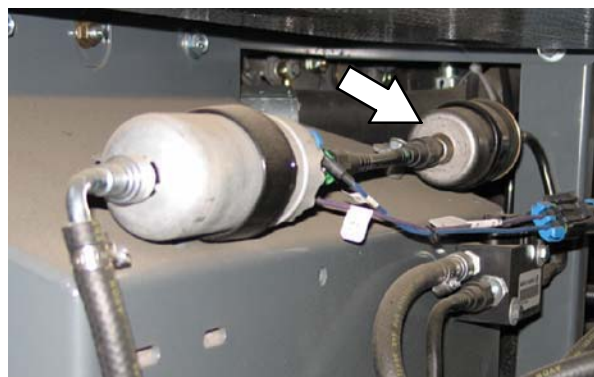

M

FUEL FILTER (LPG)

NOTE: Close the LPG tank service valve and operate the engine until it stops from lack of fuel before working on the LPG fuel system.

Replace the LPG fuel filter after every 400 hours of operation.

FOR SAFETY: When servicing machine, keep flames and sparks away from fuel system service area. Keep area well ventilated.

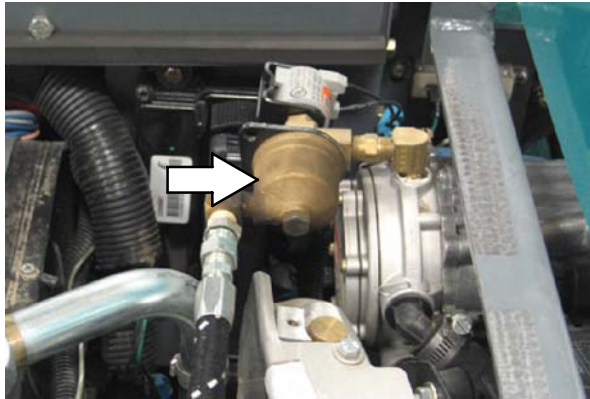

Disassemble the fuel lock off valve to access the LPG fuel filter.

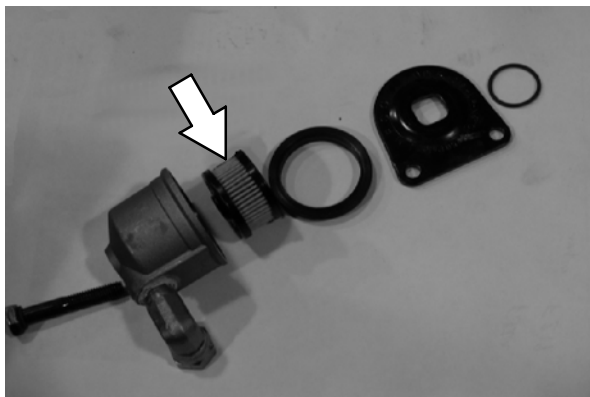

FUEL FILTER (Diesel)

Replace the fuel filter after every 800 hours of operation.

FOR SAFETY: When servicing machine, keep flames and sparks away from fuel system service area. Keep area well ventilated.



FUEL LINES (Diesel)

Check the fuel lines every 50 hours of operation. If the clamp band is loose, apply oil to the screw of the band and securely tighten the band.



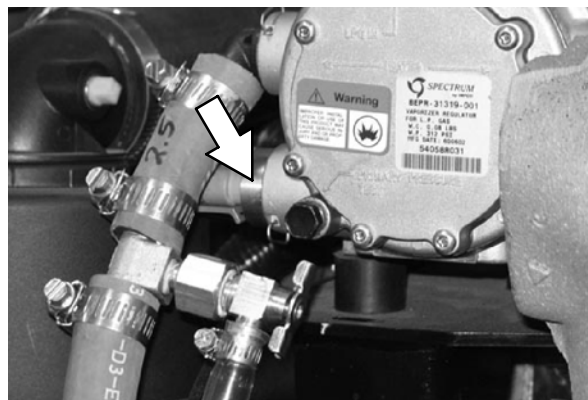

The rubber fuel lines can become worn-out whether the engine has been used much or not. Replace the fuel lines and clamp bands every two years.

FOR SAFETY: When servicing machine, keep flames and sparks away from fuel system service area. Keep area well ventilated.

If the fuel lines and clamp bands are found worn or damaged before two years' time; replace or repair them at once. Bleed the fuel system after replacement of any fuel lines, see PRIMING THE FUEL SYSTEM. When the fuel lines are not installed, plug both ends with clean cloth or paper to prevent dirt from entering the lines. Dirt in the lines can cause fuel injection pump malfunction.

PRIMING THE FUEL SYSTEM (Diesel)

Typical diesel fuel systems require priming to remove pockets of air from the fuel lines and fuel components. This is usually required after running out of fuel, changing fuel filter elements or repairing a fuel system component. Air in the fuel prevents smooth engine operation.

This fuel system however is self-priming. The return line comes from the top of the injector that allows the air to escape through the return line.

ELECTRONIC PRESSURE REGULATOR (LPG)

Remove the sensor and drain the oil from the LPG electronic pressure regulator (EPR) after every 100 hours of operation.

FOR SAFETY: When servicing machine, keep flames and sparks away from fuel system service area. Keep area well ventilated.

ENGINE BELT

Check the belt tension after every 50 hours of operation. Adjust tension as necessary. Proper belt tension is 13 mm (0.50 in) from a force of 4 to 5 kg (8 to 10 lb) applied at the mid-point of the longest span.

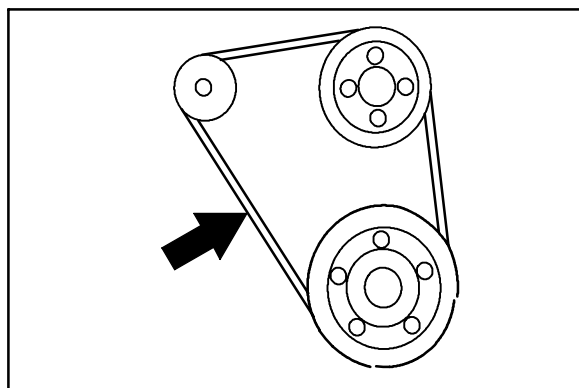

WARNING: Moving belt and fan. Keep away.

TIMING BELT (Gasoline/LPG)

Check the timing belt after every 800 hours of operation.

Replace the timing belt after every 2000 hours of operation.

SPARK PLUGS (Gasoline/LPG)

Clean or replace, and set the gap of the spark plugs after every 400 hours of operation. The proper spark plug gap is 1 mm (0.042 in).

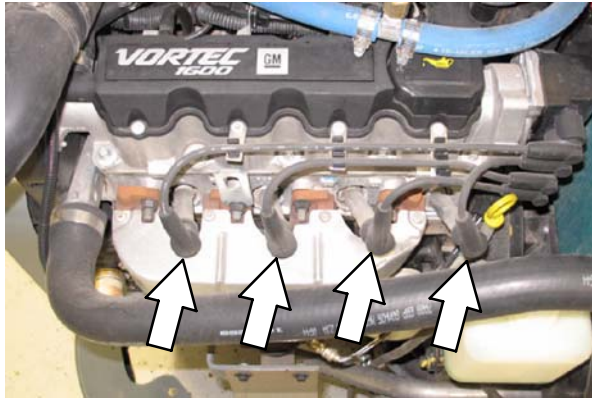

BATTERY

Clean and tighten the battery connections after the first 50 hours of operation and after every 800 hours after that. Do not remove the vent plugs from the battery or add water to the battery.

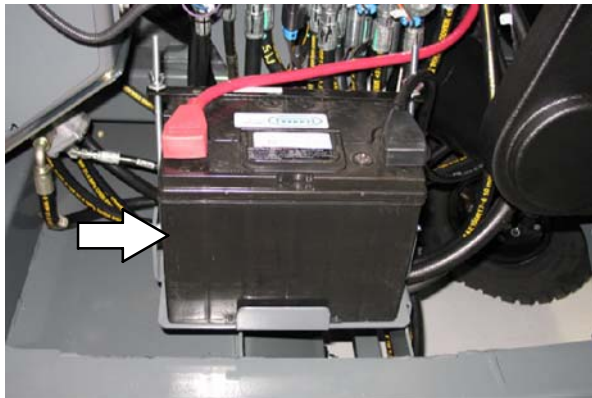

FOR SAFETY: When servicing machine, avoid contact with battery acid.

FUSES AND RELAYS

RELAY PANEL FUSES AND RELAYS

Remove the relay panel cover to access fuses and relays. Always replace a fuse with a fuse of the same amperage. Extra 15 Amp fuses are provided inside the relay panel drawer on the relay panel.



Refer to the diagram below for locations of the *fuses* and *relays* on the relay panel.

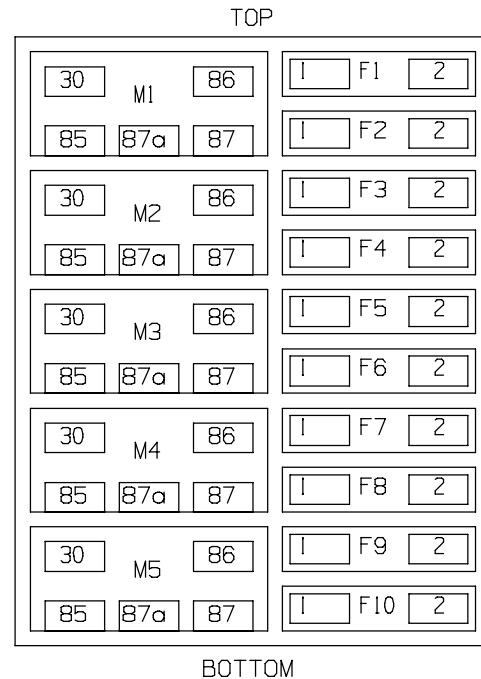

Refer to the tables below for the *fuses* and circuits protected.

S30		
Fuse	Rating	Circuit Protected
FU1	15 A	Horn
FU2	15 A	Key Switch, Engine, Instrumentation
FU3	15 A	Turn Signals, 4-Way Flashers
FU4	15 A	Extra Fused, Switched B+
FU5	15 A	Main Brush Valves, Side Brush Valves
FU6	15 A	Hopper Valves
FU7	15 A	Lights, Backup Alarm
FU8	15 A	Extra Fused B+
FU9	15 A	Shaker, Vacuum Fan Valve
FU10	15 A	Not Used
FU11	60 A	Main Power Fuse, In Line, In Main Harness
FU12	60 A	Cab Power (Optional)
FU13	40 A	Not Used
FU14	60 A	Not Used

S30XP and S30X4		
Fuse	Rating	Circuit Protected
FU1	15 A	Horn
FU2	15 A	Key Switch, Engine, Instrumentation
FU3	15 A	Turn Signals, 4-Way Flashers, Shaker
FU4	15 A	Control Board
FU5	15 A	Main Brush Valves, Side Brush Valves
FU6	15 A	Hopper Valves, Vacuum Fan Valves
FU7	15 A	Lights, Backup Alarm
FU8	15 A	Extra Fused B+
FU9	15 A	Extra Switched, Fused B+
FU10	15 A	Not Used
FU11	60 A	Main Power Fuse, In Line, In Main Harness
FU12	60 A	Cab Power (Optional)
FU13	40 A	Not Used
FU14	60 A	Not Used

NOTE: Always replace a fuse with a fuse of the same amperage.

Refer to the tables below for the *relays* and circuits controlled.

S30		
Relay	Rating	Circuit Controlled
M1	12 VDC, 40 A	Horn
M2	12 VDC, 40 A	Auxiliary 1
M3	12 VDC, 40 A	Shaker
M4	12 VDC, 40 A	Main Brush Valves, Side Brush Valves
M5	12 VDC, 40 A	Auxiliary 2

S30XP and S30X4		
Relay	Rating	Circuit Controlled
M1	12 VDC, 40 A	Horn
M2	12 VDC, 40 A	Auxiliary 1
M3	12 VDC, 40 A	Shaker
M4	12 VDC, 40 A	Not Used
M5	12 VDC, 40 A	Auxiliary 2

ENGINE HARNESS FUSES AND RELAYS (Gasoline/LPG)

The *engine harness fuses* and *relays* are located in the fuse box inside the engine compartment. Refer to the fuse box cover for locations of engine harness fuses and relays.

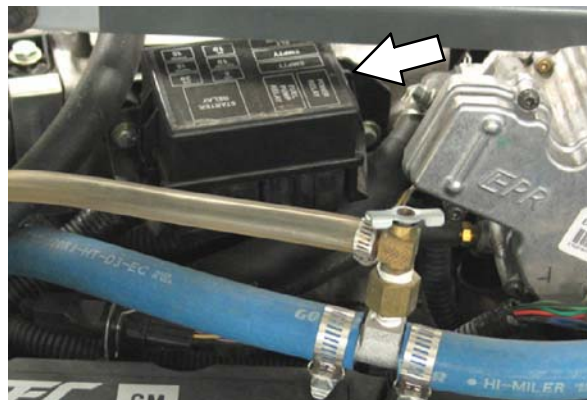

NOTE: Always replace a fuse with a fuse of the same amperage.

ENGINE HARNESS RELAYS (Diesel)

The *engine harness relays* are located inside the engine compartment.

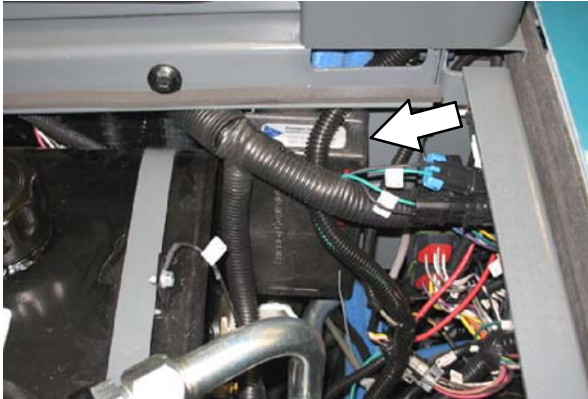

Relay	Rating	Circuit Controlled
M9	12 VDC, 40 A	Starter Solenoid
M10	12 VDC, 40 A	Anti-Restart
M11	12 VDC, 40 A	Fuel Pump
M12	12 VDC, 40 A	Glow Plug

NOTE: Always replace a fuse with a fuse of the same amperage.

CAB FUSES (CAB OPTION)

The *cab fuses* are located in the fuse box inside the cab. Remove the fuse cover to access the fuses.



Refer to the table below for the *fuses* and circuits controlled.

Fuse	Rating	Circuit Protected
FU1	5 A	Lights
FU2	5 A	Wiper
FU3	20 A	Air Conditioner
FU4	2 A	Heat

NOTE: Always replace a fuse with a fuse of the same amperage.

REMOVING AND INSPECTING THE DUST FILTER

Shake the dust filter at the end of every shift and before removing the filter from the machine. Inspect and clean the filter after every 100 hours of operation. Replace damaged dust filters.

NOTE: Clean the filter more often if used in extremely dusty conditions.

FOR SAFETY: Before leaving or servicing machine, stop on level surface, set parking brake, and turn off machine.

1. Open the top cover and side shroud.
2. Disconnect the filter shaker wire from the harness.



3. Remove the filter shaker assembly from the filter housing.

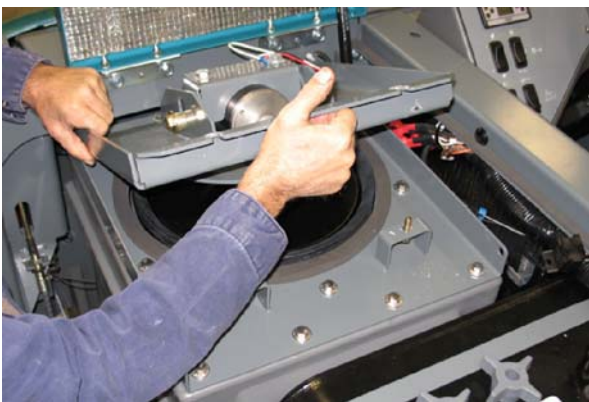

4. Remove the dust filter from the filter housing.



5. Clean or discard the dust filter element. Refer to *CLEANING THE DUST FILTER*.
6. Insert the dust filter into the filter housing and reinstall the removed parts. Be sure the seal is installed as shown below.



7. Close the side shroud and top cover.

CLEANING THE DUST FILTER

Use one of the following methods to clean the dust filter:

SHAKING—Press the *filter shaker switch*.

TAPPING—Tap the filter gently on a flat surface. **Do not damage the edges of the filter.** The filter will not seal properly if the edges of the filter are damaged.

AIR—Always wear eye protection when using compressed air. Blow air through the center of the filter and out toward the exterior. Never use more than 550 kPa (80 psi) of air pressure with a nozzle no smaller than 3 mm (0.13 in) and never hold the nozzle closer than 50 mm (2 in) to the filter.

FOR SAFETY: When servicing machine, wear eye and ear protection when using pressurized air or water.



MAIN BRUSH

Check the brush daily for wear or damage. Remove any string or wire tangled on the main brush, main brush drive hub, or main brush idler hub.



Check the main brush pattern and rotate the brush end-for-end after every 50 hours of operation, for maximum brush life and best sweeping performance. Refer to *REPLACING OR ROTATING THE MAIN BRUSH*.

Replace the main brush when the remaining bristles measure 25 mm (1.0 in) in length.

REPLACING OR ROTATING THE MAIN BRUSH

1. Raise the brush head.

FOR SAFETY: Before leaving or servicing machine, stop on level surface, set parking brake, and turn off machine.

2. Open the right side main brush access door.



3. Unlatch and remove the brush idler plate.



4. Pull the main brush from the main brush compartment.



5. Replace or rotate the main brush end-for-end.
6. Slide the brush into the brush compartment and all the way onto the drive plug.
7. Reinstall the brush idler plate.

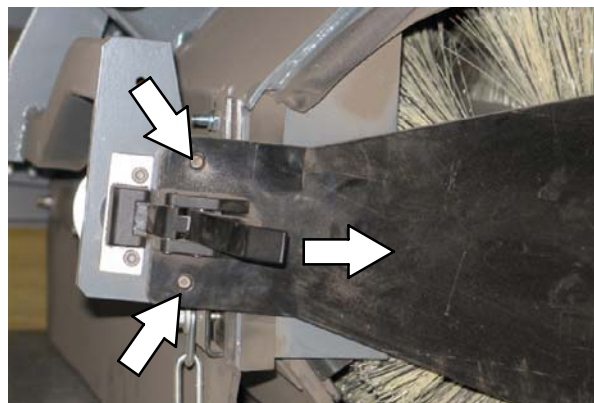

8. Close the right side main brush access door.
9. Check and adjust the brush pattern if needed. Refer to *CHECKING THE MAIN BRUSH PATTERN*.

CHECKING THE MAIN BRUSH PATTERN

1. Apply chalk, or a similar marking material, to a smooth and level section of the floor.

NOTE: If chalk or other material is not available, allow the brush to spin on the floor for two minutes. A polish mark will remain on the floor.

2. Lower the main brush onto the chalked area and hold it there for 15 to 20 seconds without moving the machine.
3. Raise the brush and drive the machine from the chalked area. The brush pattern should be 50 to 65 mm (2.0 to 2.5 in) across the entire length of the brush. Refer to *ADJUSTING THE MAIN BRUSH WIDTH*.

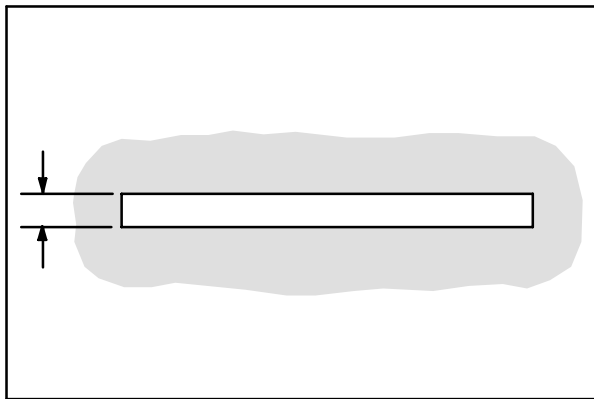

00582

4. If the brush pattern is tapered, see *ADJUSTING THE MAIN BRUSH TAPER* section of this manual.

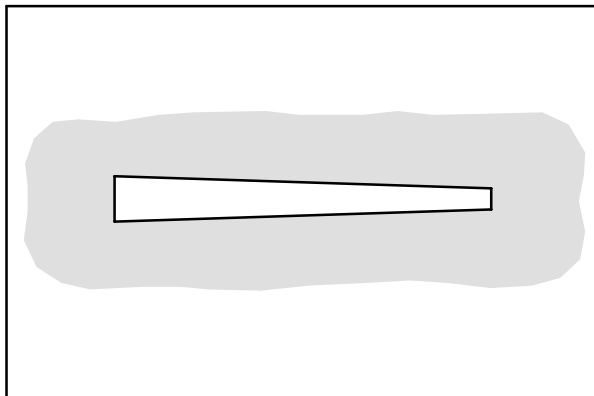

00601

ADJUSTING THE MAIN BRUSH TAPER

FOR SAFETY: Before leaving or servicing machine, stop on level surface, set parking brake, and turn off machine.

1. Loosen the shaft bearing bracket mounting bolts.

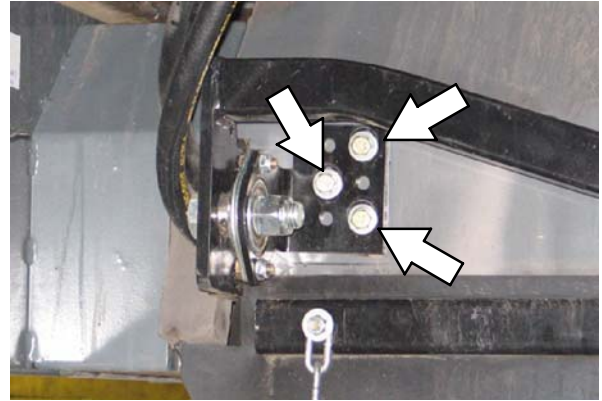

2. Move the bracket up or down in the slots and tighten the mounting bolts.
3. Check the main brush pattern and readjust as necessary. Set the main brush adjustment knob pointer to the same color band as the brush idler plate.

ADJUSTING THE MAIN BRUSH WIDTH

FOR SAFETY: Before leaving or servicing machine, stop on level surface, set parking brake, and turn off machine.

1. Compare the length of the main brush bristles with the color band on the brush idler plate.

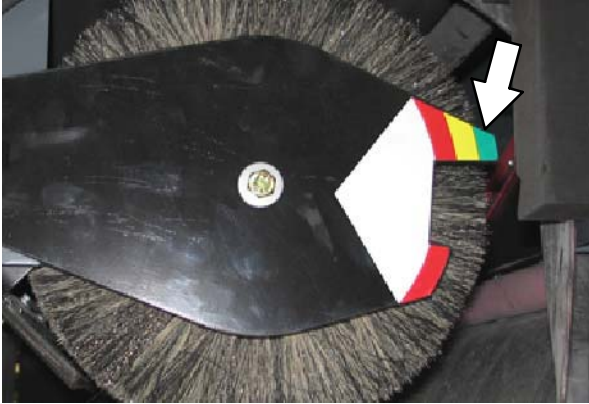

2. Loosen the main brush adjustment knob and slide the pointer so it matches the color band on the brush idler plate. Retighten the knob.

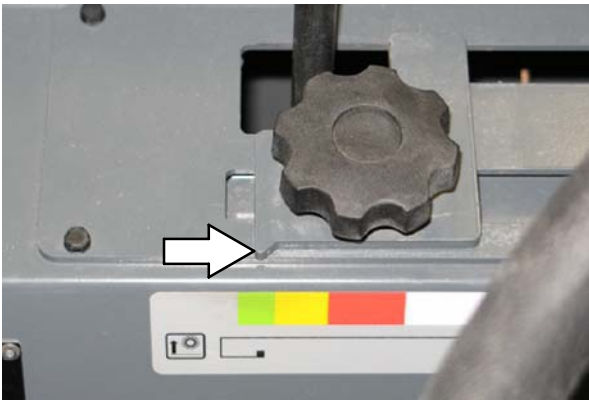

3. Recheck the pattern. Readjust if necessary.

SIDE BRUSH

Check the side brush daily for wear or damage. Remove any tangled string or wire from the side brush or side brush drive hub.

REPLACING THE SIDE BRUSH

Replace the side brush when it no longer cleans effectively or when the remaining bristles are 64 mm (2.5 in) or less in length. The side brush may be changed sooner if sweeping light litter. The bristles may be worn shorter if sweeping heavy debris.

1. Raise the side brush.

FOR SAFETY: Before leaving or servicing machine, stop on level surface, set parking brake, and turn off machine.

2. Remove the side brush retaining pin and then remove the side brush.

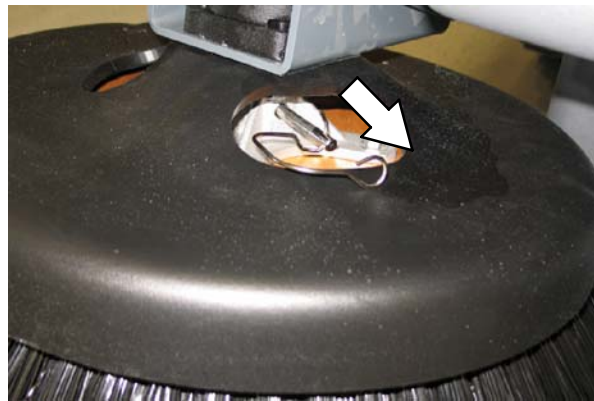

NOTE: Remove the drive hub and put it on the new brush if one is not installed.

3. Slide the new side brush onto the side brush drive shaft and reinstall the retaining pin.
4. Adjust the side brush pattern. Refer to *ADJUSTING THE SIDE BRUSH PATTERN*.

ADJUSTING THE SIDE BRUSH PATTERN

The side brush bristles should touch the floor between 10 o'clock and 4 o'clock when the brush is in motion.

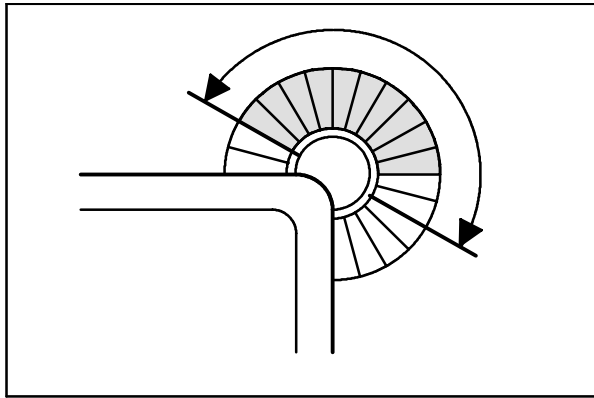

350327

S30: Turn the *side brush adjustment knob* counterclockwise to increase the brush pattern and clockwise to decrease the brush pattern.

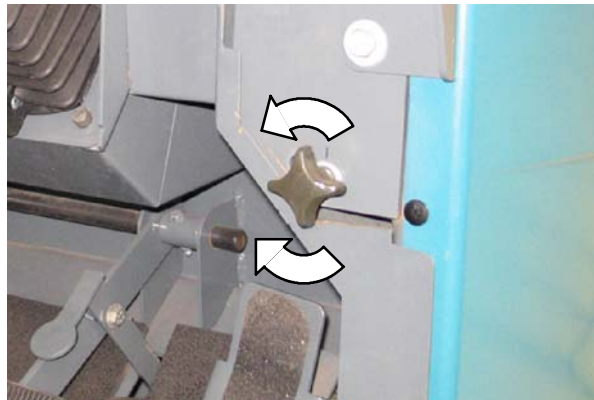

S30XP and S30X4: Tighten the *side brush adjustment knob* into the side brush bracket to increase the brush pattern and loosen the knob to decrease the brush pattern.

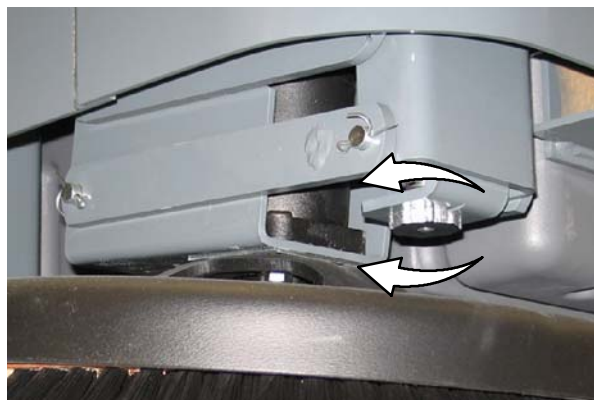

ROTATING AND REPLACING THE SIDE BRUSH GUARD

Rotate the side brush guard 90° every 200 hours of operation. Replace the brush guard after all four sides have been used.



SKIRTS AND FLAPS

HOPPER SKIRTS

Check the hopper skirts for wear or damage daily. Replace the hopper skirts when they no longer touch the floor.

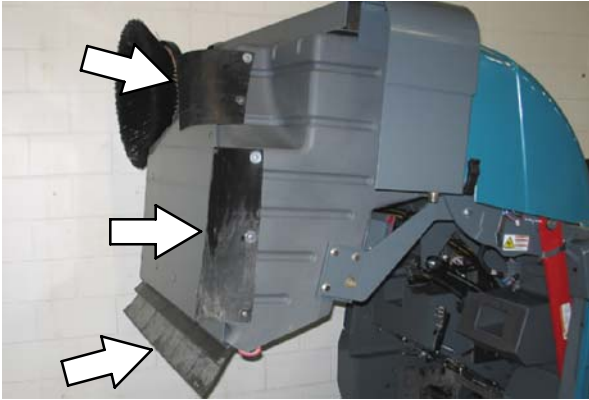

BRUSH DOOR SKIRTS

NOTE: Be sure the rear tire is properly inflated before checking skirt clearances.

The brush door skirts should clear the floor by 3 to 6 mm (0.12 to 0.25 in). Check the skirts for wear or damage and adjustment daily.

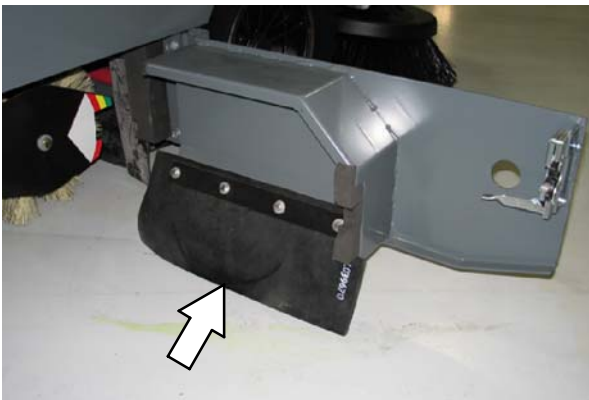

NOTE: The brush door skirts have slotted holes to allow for a ground clearance adjustment. The door must be closed for proper adjustment.

REAR SKIRT

NOTE: Be sure the rear tire is properly inflated before checking skirt clearances.

The rear brush skirt should clear the floor by 3 to 6 mm (0.12 to 0.25 in). Check the skirt for wear or damage and adjustment daily.

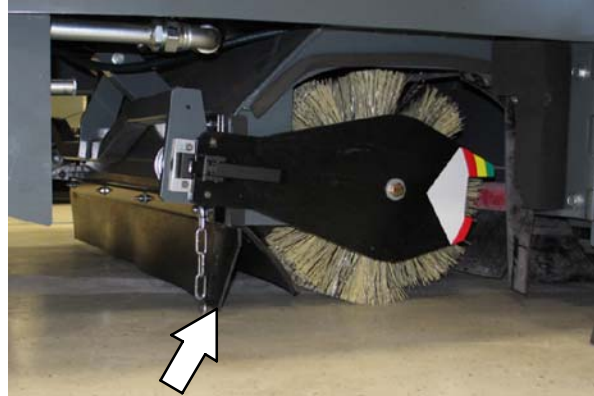

RECIRCULATION FLAP

The recirculation flap is self-adjusting. Check the flap for wear or damage daily.

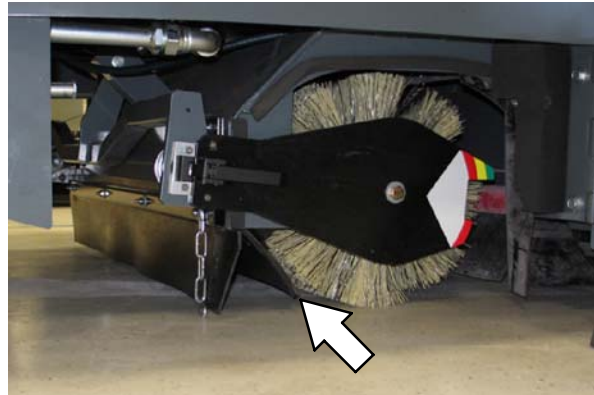

SEALS

BRUSH DOOR SEALS

Check the brush door seals for wear or damage every 100 hours of operation.

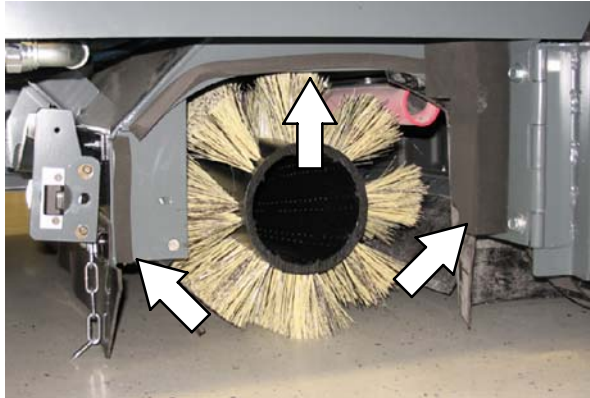

DUST FILTER SEALS

Check the dust filter seals for wear or damage every 100 hours of operation.

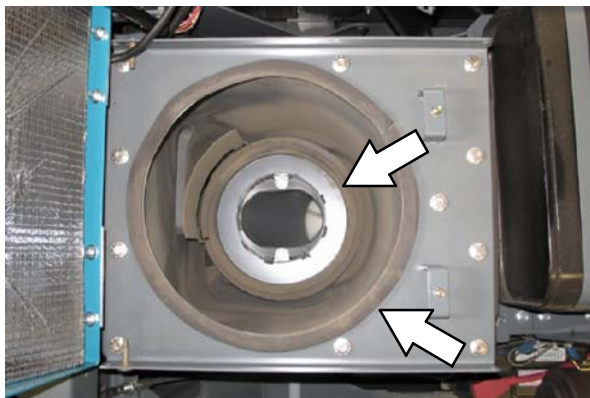

HOPPER SEALS

Check the hopper door seals for wear or damage every 100 hours of operation.

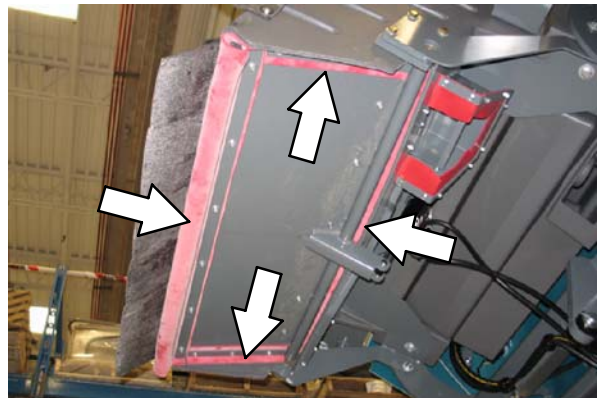
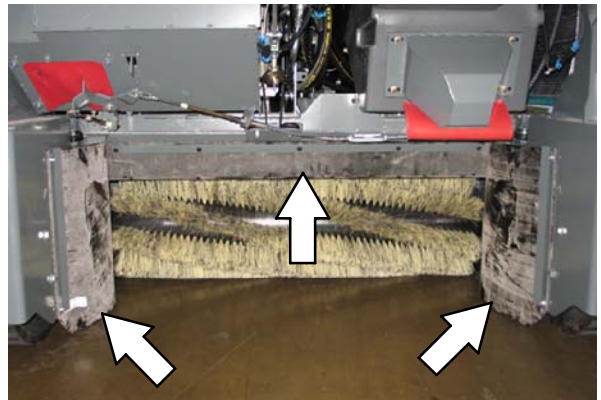

HOPPER INSPECTION DOOR SEALS

Check the hopper inspection door seal for wear or damage every 100 hours of operation.



M

FILTER CHAMBER INLET SEAL

Check the filter chamber inlet seal for wear or damage every 100 hours of operation.

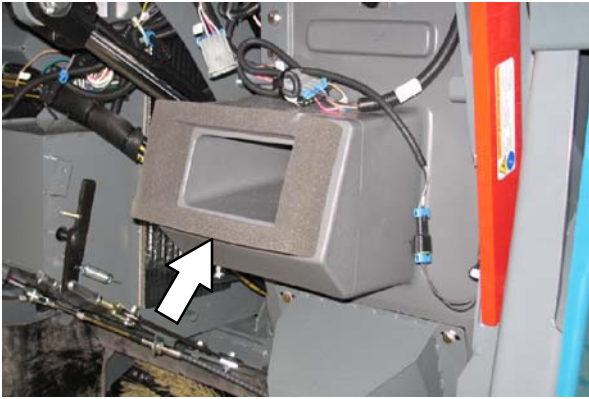

VACUUM WAND DOOR SEALS (OPTION)

Check the vacuum wand door seal for wear or damage every 100 hours of operation.

CYCLONIC PRE-FILTER SEALS

Check the cyclonic pre-filter seals for wear or damage every 100 hours of operation.

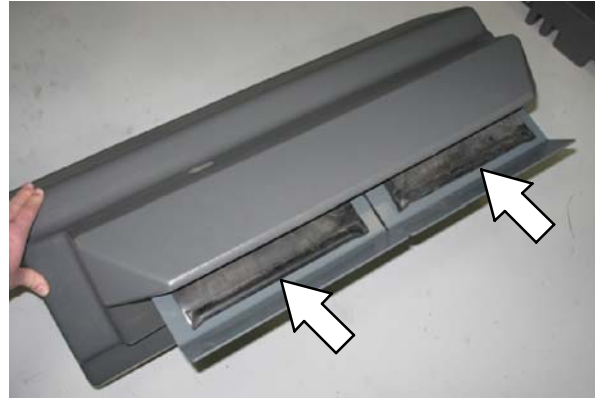

DUST RETURN SEALS

Check the dust return seals for wear or damage every 100 hours of operation.

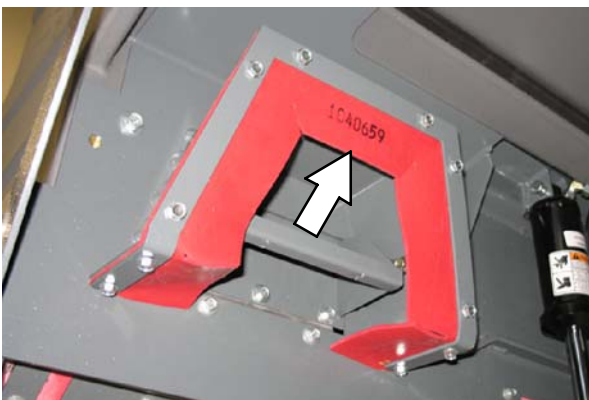
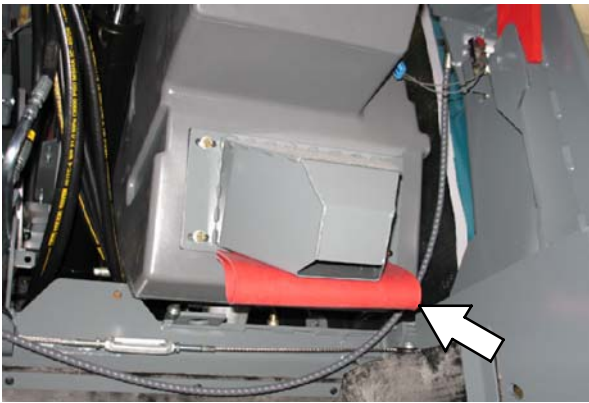

BRAKES AND TIRES**BRAKES**

Check the brake adjustment after every 200 hours of operation.

PARKING BRAKE

Check the parking brake adjustment after every 200 hours of operation.

TIRES

The standard front tires are solid. The standard rear tire is pneumatic.

Check the rear tire pressure every 100 hours of operation. The proper air pressure is 790 ± 35 kPa (115 ± 5 psi).

REAR WHEEL

Torque the rear wheel nuts twice in the pattern shown to 122 to 149 Nm (90 to 110 ft lb) after the first 50 hours of operation, and then after every 800 hours.

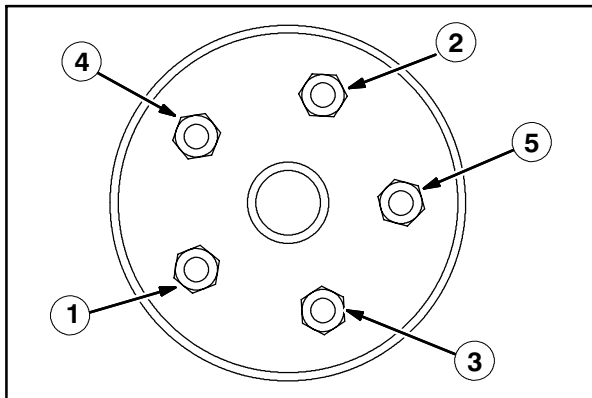
**PROPELLING MOTOR**

Torque the shaft nut to 508 Nm (375 ft lb) lubricated, 644 Nm (475 ft lb) dry, after every 800 hours of operation.



PUSHING, TOWING, AND TRANSPORTING THE MACHINE

PUSHING OR TOWING THE MACHINE

If the machine becomes disabled, it can be pushed from the front or rear, but only towed from the rear.

Use the *bypass valve* to prevent damaging the hydraulic system when pushing or towing the machine. This valve allows a disabled machine to be moved for a *very short distance* and at a speed to not exceed 1.6 kp/h (1 mph). The machine is NOT intended to be pushed or towed a long distance or at a high speed.

ATTENTION! Do not push or tow machine for a long distance or damage may occur to the propelling system.

Turn the *bypass valve* located on the bottom of the propelling pump 90° (either direction) from the normal position before pushing or towing the machine. Return the bypass valve to the normal position when finished pushing or towing the machine. **Do Not** use the bypass valve during normal machine operation.

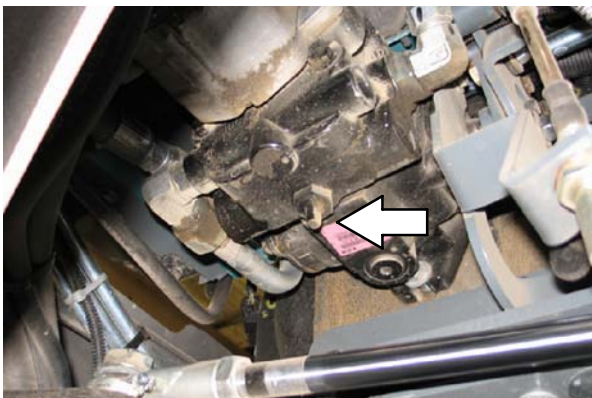
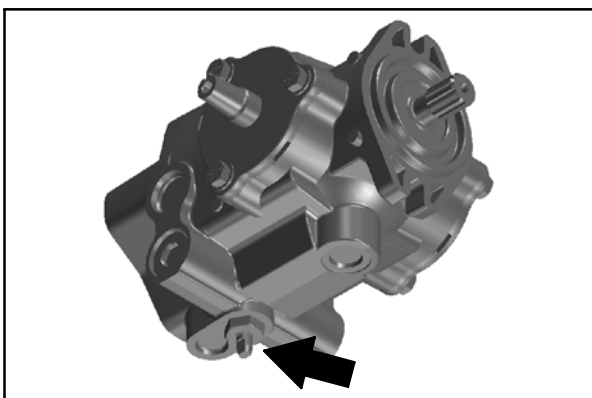

TRANSPORTING THE MACHINE

1. Raise the brushes. If necessary, slightly raise the hopper for additional ramp clearance.

NOTE: Empty the hopper before transporting.

2. Position the front of the machine at the loading edge of the truck or trailer.

FOR SAFETY: When loading machine onto truck or trailer, use winch. Do not drive the machine onto the truck or trailer unless the loading surface is horizontal AND is 380 mm (15 in) or less from the ground.

3. If the loading surface is horizontal and 380 mm (15 in) or less from the ground, drive the machine onto the truck or trailer.

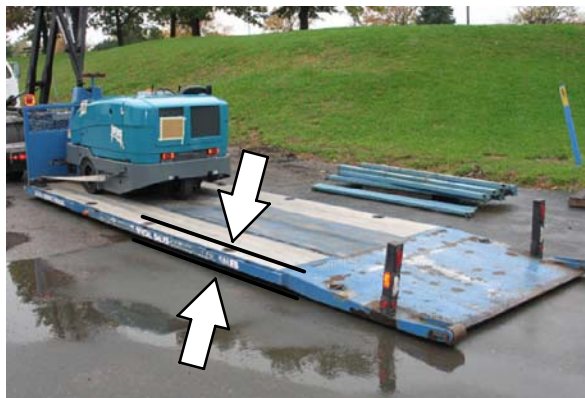

4. To winch the machine onto the truck or trailer, attach the winching chains to the holes in the right and left lower corners in front of the machine.



5. Position the machine as close to the front of the trailer or truck as possible.
6. Set the parking brake and place a block behind each wheel to prevent the machine from rolling.
7. Lower the brushes and hopper (if hopper was raised).
8. Connect the tie-down straps to the holes in the right and left lower corners in front of the machine and the holes in the rear jacking brackets behind the rear tires.

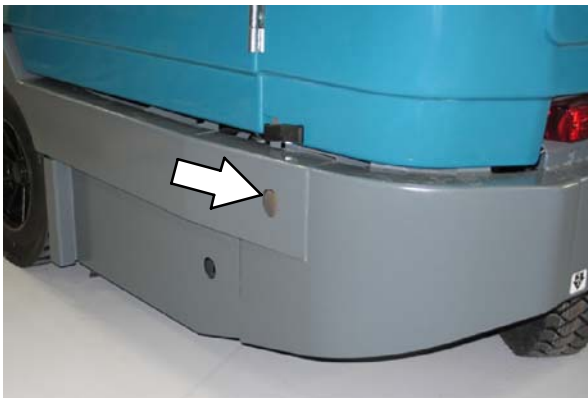
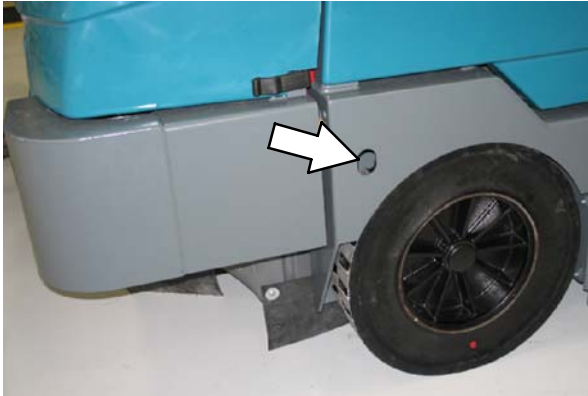

9. Route the tie-downs to the opposite ends of the machine and hook them to the brackets on the floor of the trailer or truck. Tighten the tie-down straps.

NOTE: It may be necessary to install tie-down brackets to the floor of the trailer or truck.



FOR SAFETY: When unloading machine off truck or trailer, use winch. Do not drive the machine off the truck or trailer unless the loading surface is horizontal AND 380 mm (15 in) or less from the ground.

10. If the loading surface is horizontal AND is 380 mm (15 in) or less from the ground, drive the machine off the truck or trailer.

MACHINE JACKING

Empty the hopper before jacking up the machine. Jack up the machine at the designated locations. Use a hoist or jack capable of supporting the weight of the machine. Use jack stands to support the machine.

FOR SAFETY: Before leaving or servicing machine, stop on level surface, set parking brake, and turn off machine.

FOR SAFETY: When servicing machine, block machine tires before jacking machine up. Use a hoist or jack that will support the weight of the machine. Jack machine up at designated locations only. Support machine with jack stands.

Rear jacking locations are located directly behind the rear tire on each side of the machine.



Front jacking locations are located on the frame directly in front of the front tire.

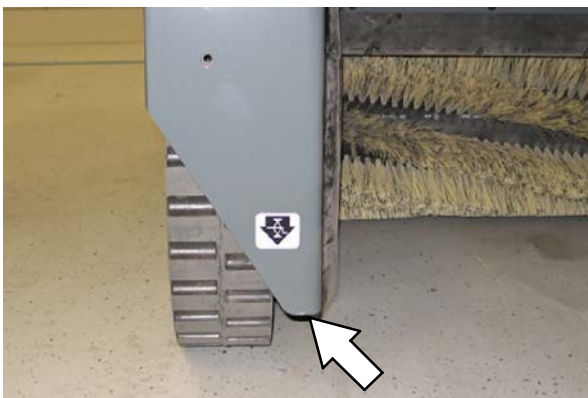

STORAGE INFORMATION

The following steps should be taken prior to storing the machine for extended periods.

1. Park the machine in a cool, dry area. Do not expose the machine to rain or snow. Store indoors.
2. Remove the battery, or charge battery every three months.

M

ELECTRICAL

Troubleshooting Information

BEFORE CONDUCTING TESTS:

- * Read and Follow ALL Safety Warnings and Precautions as mentioned at the beginning of this manual
- * Always use an ESD (Electrostatic Discharge) strap when working near the Control Board
- * Be cautious when working near Control Board - **Battery voltage is always present, even with Key OFF**
- * Always unhook Battery when removing or replacing components

DURING TESTS:

- * Call Technical Services if Diagnostic Time Exceeds One Hour With Unknown Cause or Course of Action

NOTE: Troubleshooting charts may be shown with optional equipment. The optional equipment may not be specified in these charts. Some machines may not be equipped with all components shown.

Electrical Symbols & Abbreviations

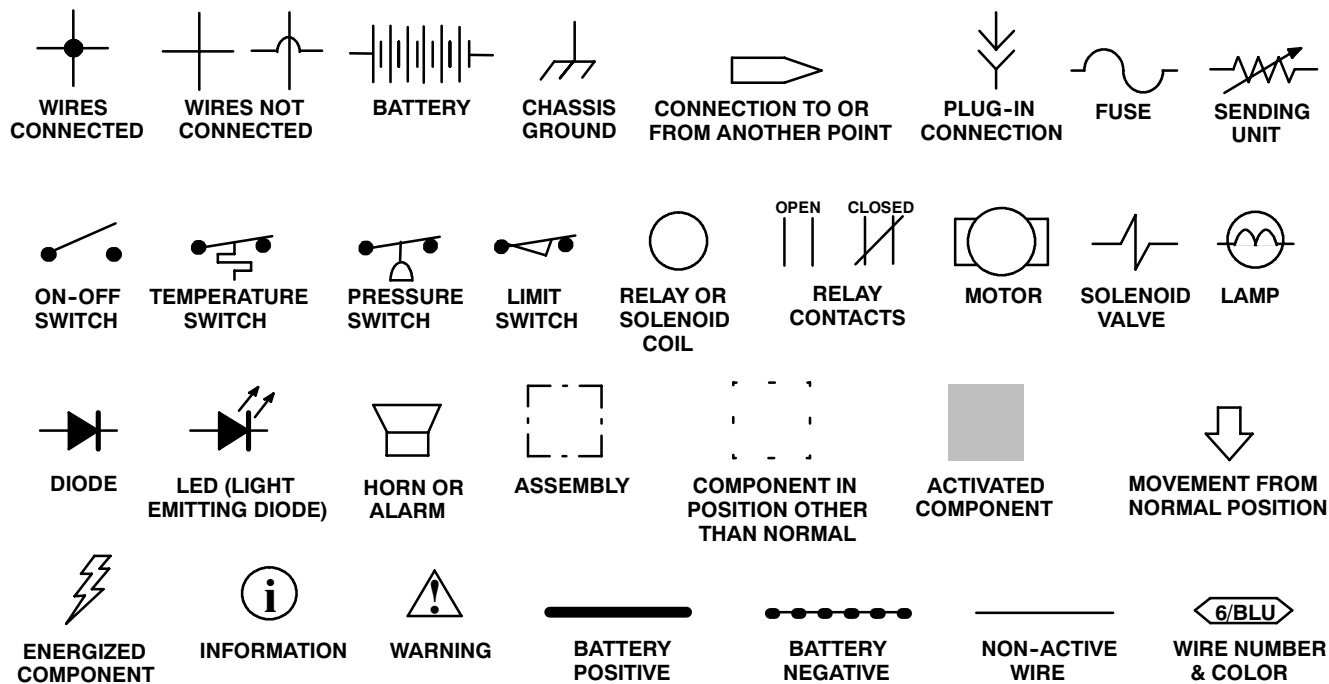

ABBREVIATIONS

A	Amps
ACT	Actuator
B+	Battery Positive
CKT	Circuit
D	Diode
F	Fuse
GND	Ground
LP	Lamp
M	Relay Coil
MTR	Motor
NC	Normally Closed
NO	Normally Open
PM	Permanent Magnet
S or SW	Switch
SV	Solenoid Valve
TMR	Timer
VDC	Volts, Direct Current

Wire Colors	
BLK	Black
BLU	Blue
BRN	Brown
GRN	Green
GRY	Gray
ORA	Orange
PNK	Pink
PUR	Purple
RED	Red
TAN	Tan
WHT	White
YEL	Yellow

Fuses and Relays (S30,S30XP,S30X4)

(page 1 of 2)

RELAY PANEL FUSES AND RELAYS

Remove the relay panel cover to access fuses and relays. Always replace a fuse with a fuse of the same amperage. Extra 15 Amp fuses are provided inside the relay panel drawer on the relay panel.



Refer to the diagram below for locations of the fuses and relays on the relay panel.

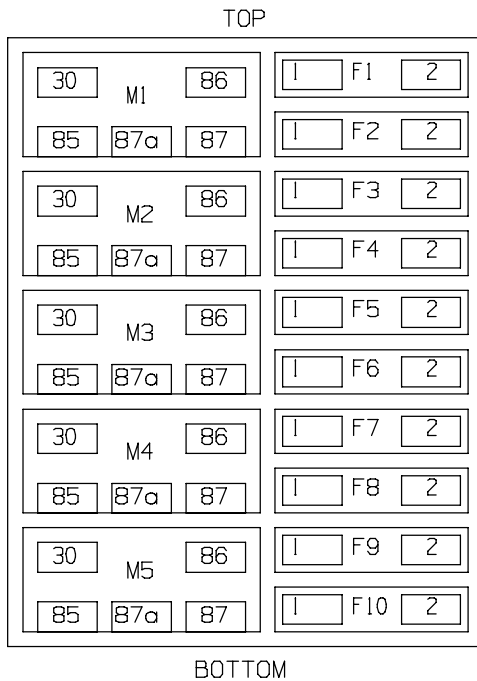

Refer to the tables below for the fuses and circuits protected.

S30		
Fuse	Rating	Circuit Protected
FU1	15 A	Horn
FU2	15 A	Key Switch, Engine, Instrumentation
FU3	15 A	Turn Signals, 4-Way Flashers
FU4	15 A	Extra Fused, Switched B+
FU5	15 A	Main Brush Valves, Side Brush Valves
FU6	15 A	Hopper Valves
FU7	15 A	Lights, Backup Alarm
FU8	15 A	Extra Fused B+
FU9	15 A	Shaker, Vacuum Fan Valve
FU10	15 A	Not Used
FU11	60 A	Main Power Fuse, In Line, In Main Harness
FU12	60 A	Cab Power (Optional)
FU13	40 A	Not Used
FU14	60 A	Not Used

S30 XP and X4		
Fuse	Rating	Circuit Protected
FU1	15 A	Horn
FU2	15 A	Key Switch, Engine, Instrumentation
FU3	15 A	Turn Signals, 4-Way Flashers, Shaker
FU4	15 A	Control Board
FU5	15 A	Main Brush Valves, Side Brush Valves
FU6	15 A	Hopper Valves, Vacuum Fan Valves
FU7	15 A	Lights, Backup Alarm
FU8	15 A	Extra Fused B+
FU9	15 A	Extra Switched, Fused B+
FU10	15 A	Not Used
FU11	60 A	Main Power Fuse, In Line, In Main Harness
FU12	60 A	Cab Power (Optional)
FU13	40 A	Not Used
FU14	60 A	Not Used

NOTE: Always replace a fuse with a fuse of the same amperage.

Fuses and Relays (S30,S30XP,S30X4)

(page 2 of 2)

Refer to the tables below for the *relays* and circuits controlled.

S30		
Relay	Rating	Circuit Controlled
M1	12 VDC, 40 A	Horn
M2	12 VDC, 40 A	Auxiliary 1
M3	12 VDC, 40 A	Shaker
M4	12 VDC, 40 A	Main Brush Valves, Side Brush Valves
M5	12 VDC, 40 A	Auxiliary 2

S30 XP and X4		
Relay	Rating	Circuit Controlled
M1	12 VDC, 40 A	Horn
M2	12 VDC, 40 A	Auxiliary 1
M3	12 VDC, 40 A	Shaker
M4	12 VDC, 40 A	Not Used
M5	12 VDC, 40 A	Auxiliary 2

ENGINE HARNESS FUSES AND RELAYS

The *engine harness fuses and relays* are located in the fuse box inside the engine compartment. Refer to the fuse box cover for locations of engine harness fuses and relays.

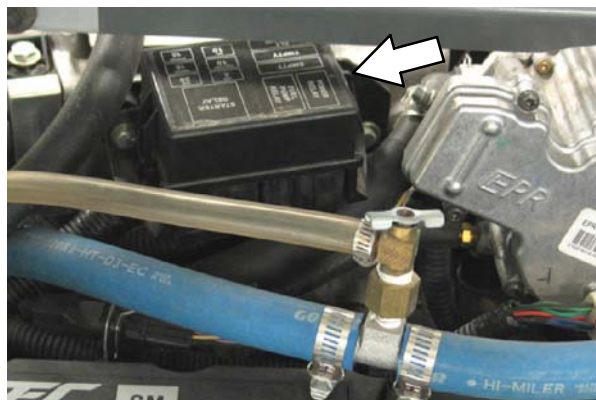

NOTE: Always replace a fuse with a fuse of the same amperage.

CAB FUSES (CAB OPTION)

The *cab fuses* are located in the fuse box inside the cab. Remove the fuse cover to access the fuses.



Refer to the table below for the *fuses* and circuits controlled.

Fuse	Rating	Circuit Protected
FU1	5 A	Lights
FU2	5 A	Wiper
FU3	20 A	Air Conditioner
FU4	2 A	Heat

NOTE: Always replace a fuse with a fuse of the same amperage.

S30 Electrical Schematic (2 of 4)

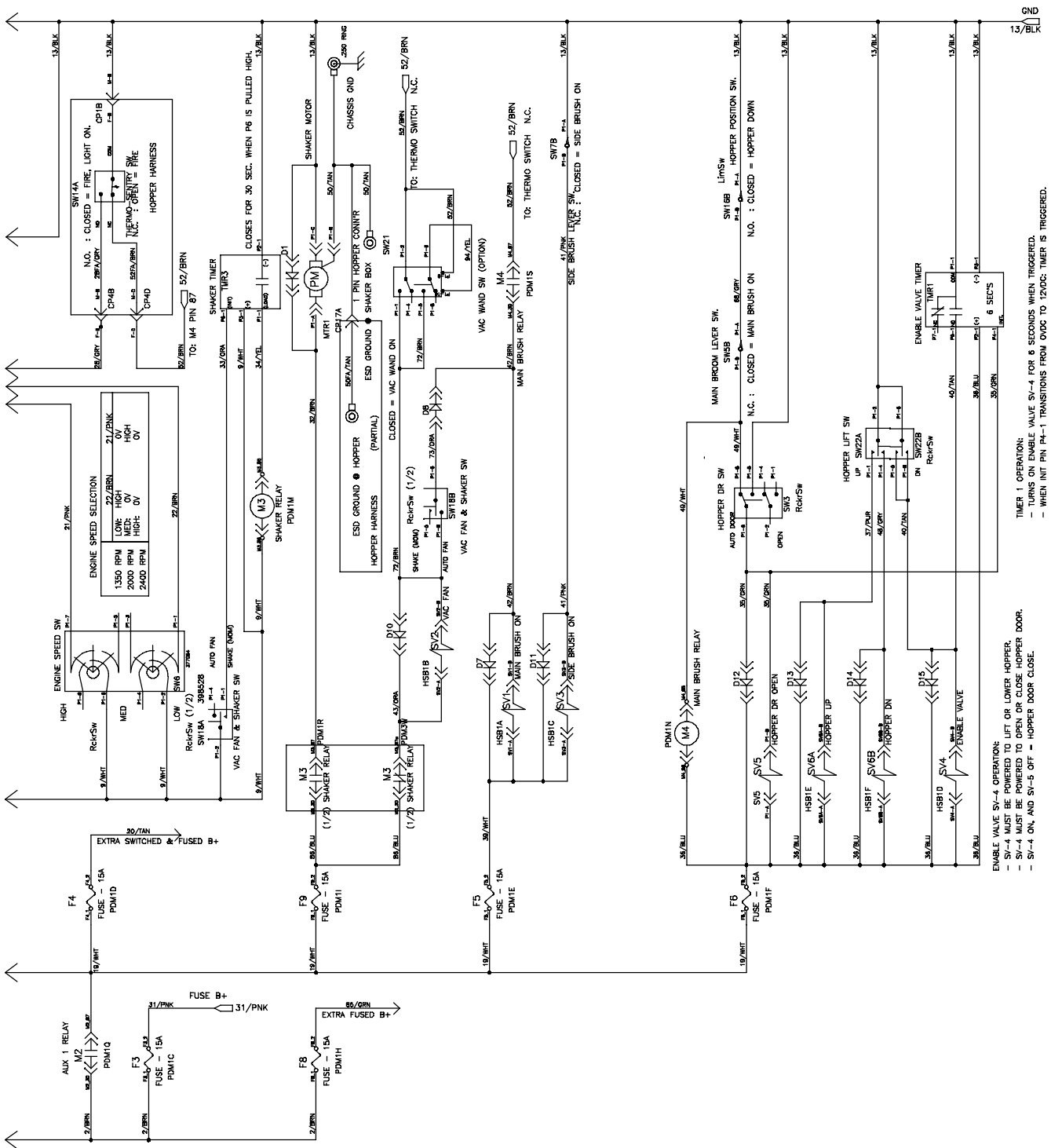

ENABLE VALVE SV-4 OPERATION:
 - SV-4 MUST BE POWERED TO LIFT OR LOWER HOPPER.
 - SV-4 MUST BE POWERED TO OPEN OR CLOSE HOPPER DOOR.
 - SV-4 ON, AND SV-5 OFF = HOPPER DOOR CLOSE.

TIMER 1 OPERATION:
 - TURNS ON ENABLE VALVE SV-4 FOR 6 SECONDS WHEN TRIGGERED.
 - WHEN INIT PIN PA-1 TRANSITIONS FROM 0VDC TO 12VDC: TIMER IS TRIGGERED.
 - WHEN INIT PIN PA-1 TRANSITIONS FROM 12VDC TO 0VDC: TIMER IS TRIGGERED.

S30 Electrical Schematic (3 of 4)

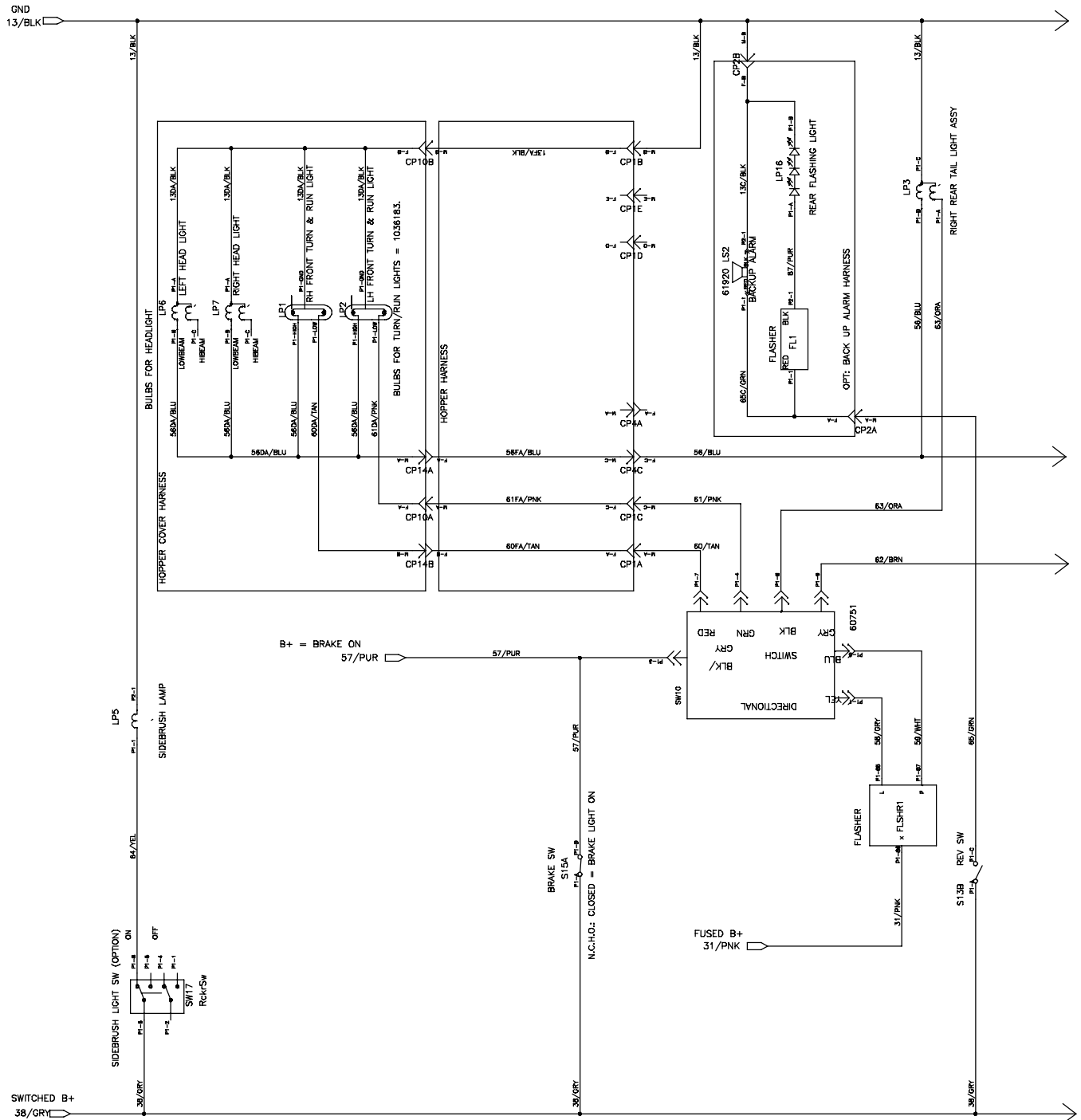

S30 Electrical Schematic (4 of 4)

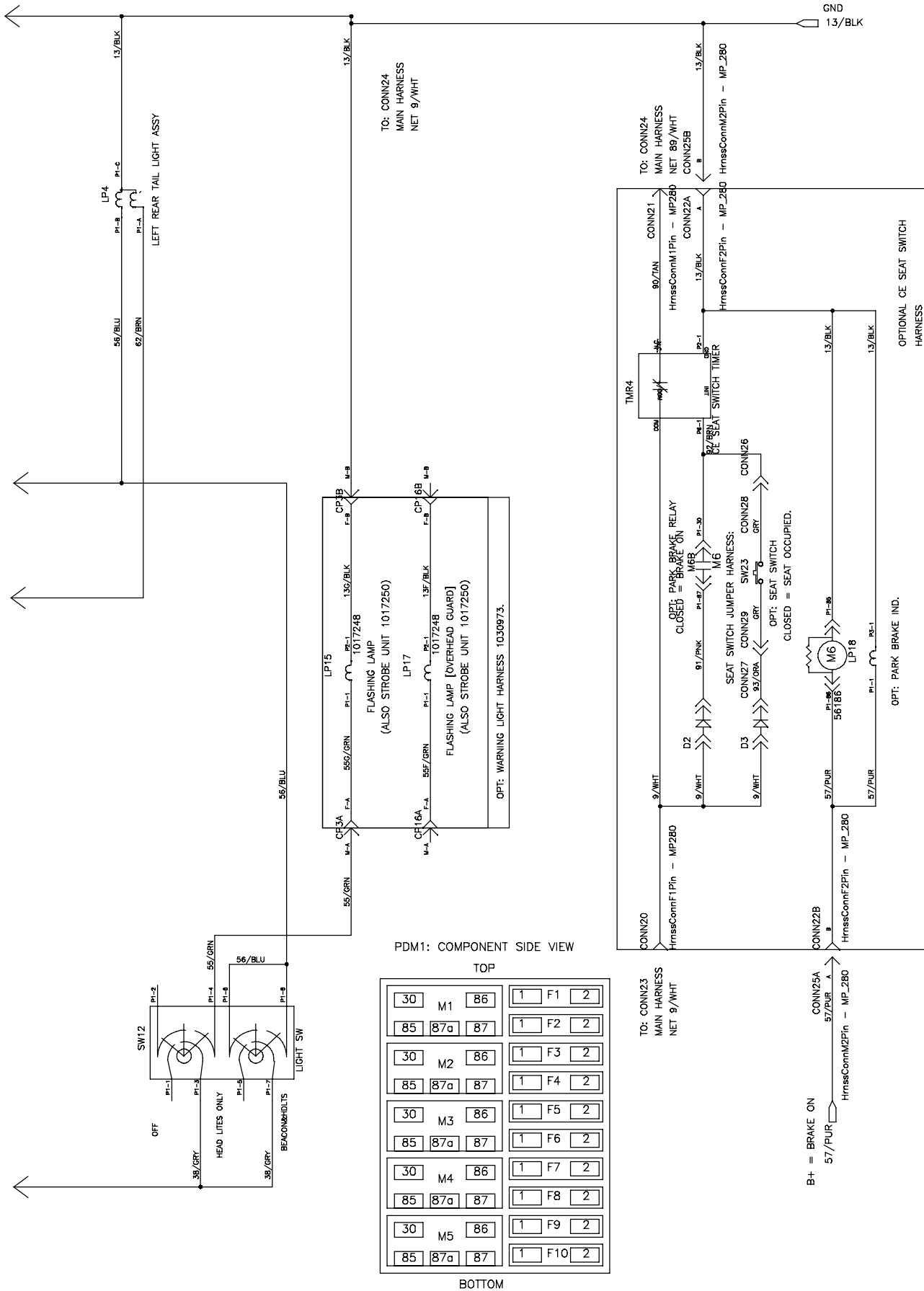

S30XP / S30X4 Electrical Schematic (1 of 4)

DIESEL: CONNECTS TO DIESEL ENG. HARNESS
 GAS: CONNECTS TO GAS TIER2 ENG. HARNESS
 L.P.: CONNECTS TO L.P. TIER2 ENG. HARNESS

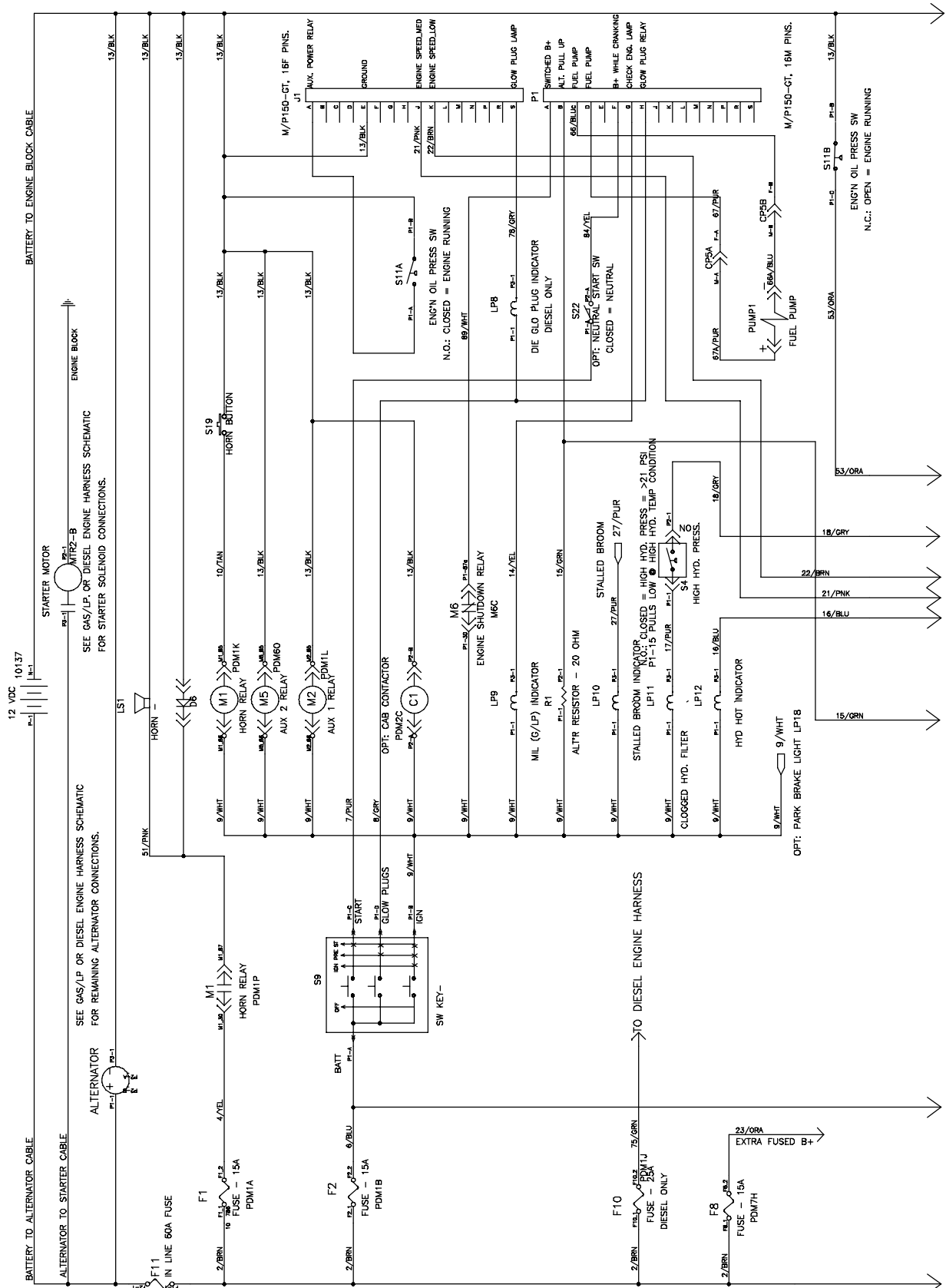

S30XP / S30X4 Electrical Schematic (2 of 4)

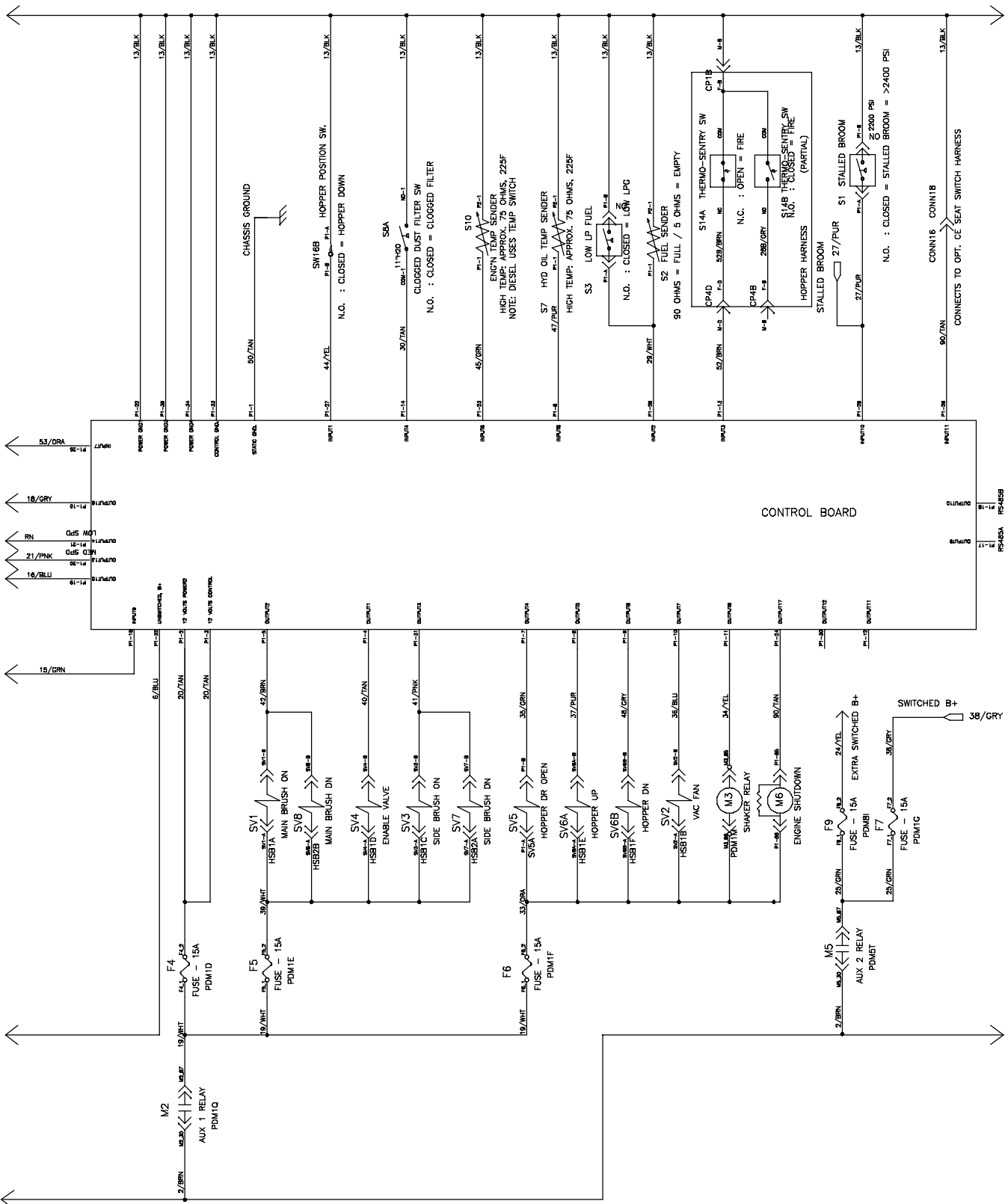

1029279- 354729

S30XP / S30X4 Electrical Schematic (3 of 4)

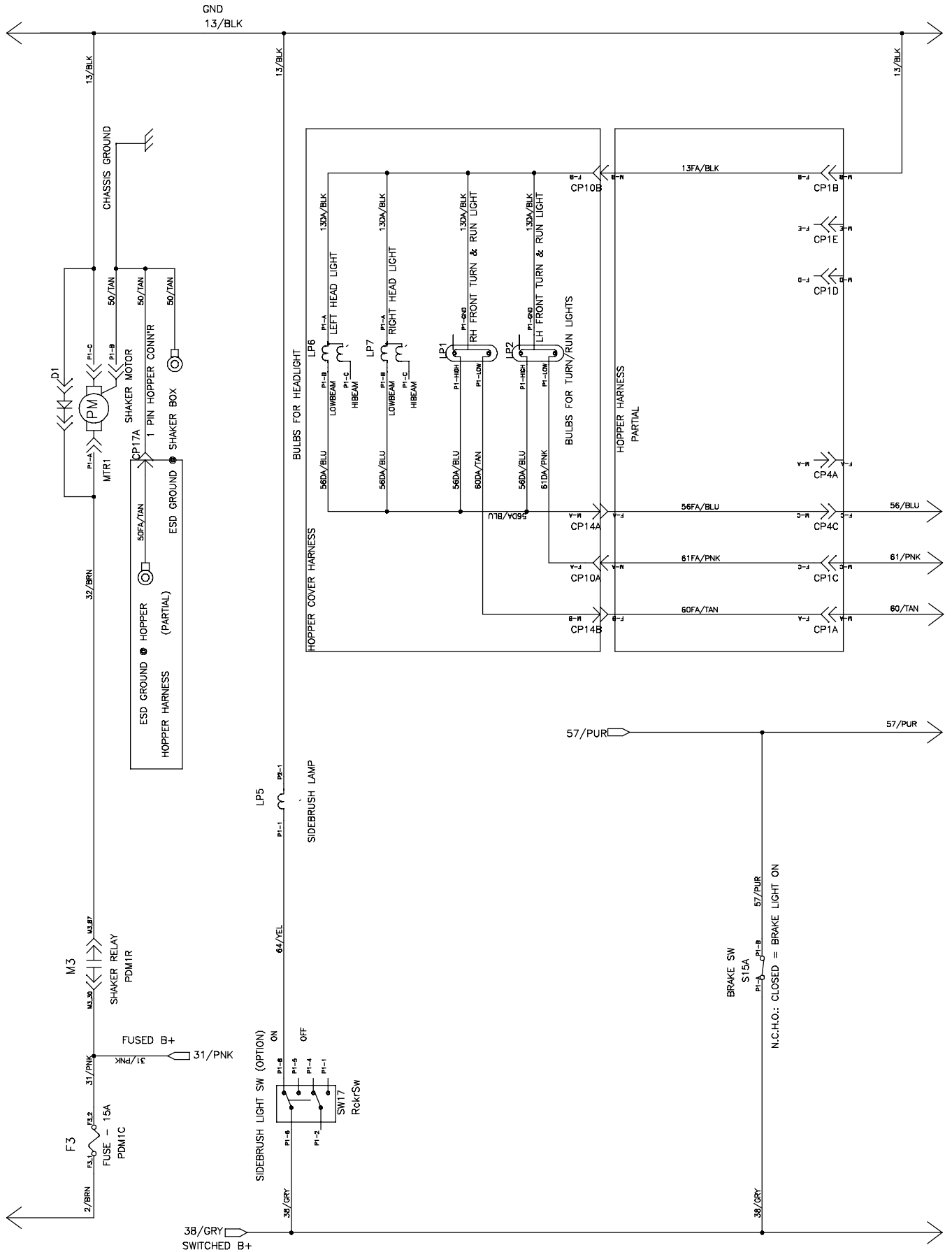

S30XP / S30X4 Electrical Schematic (4 of 4)

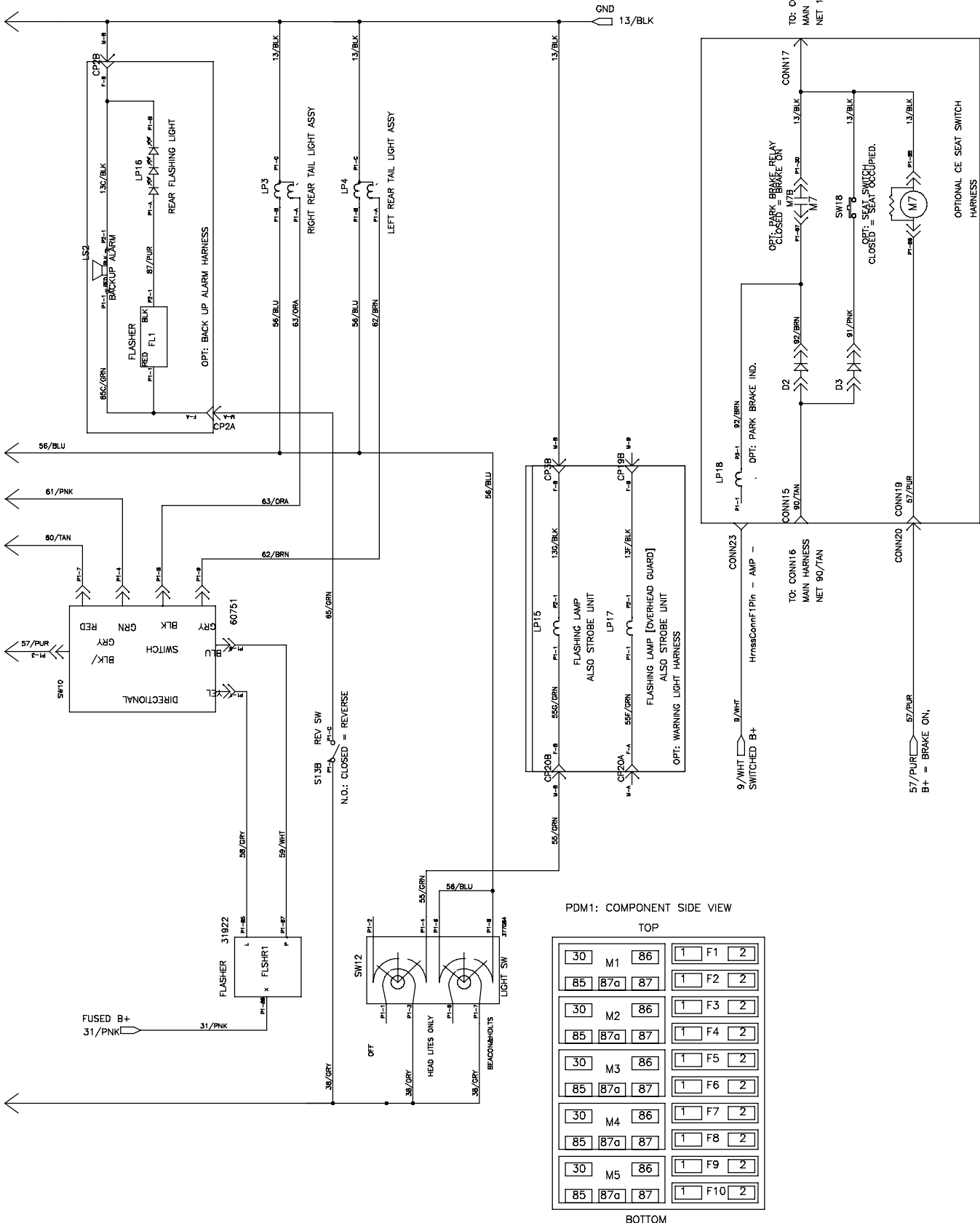

Gasoline Engine Harness Electrical Schematic (1 of 2)

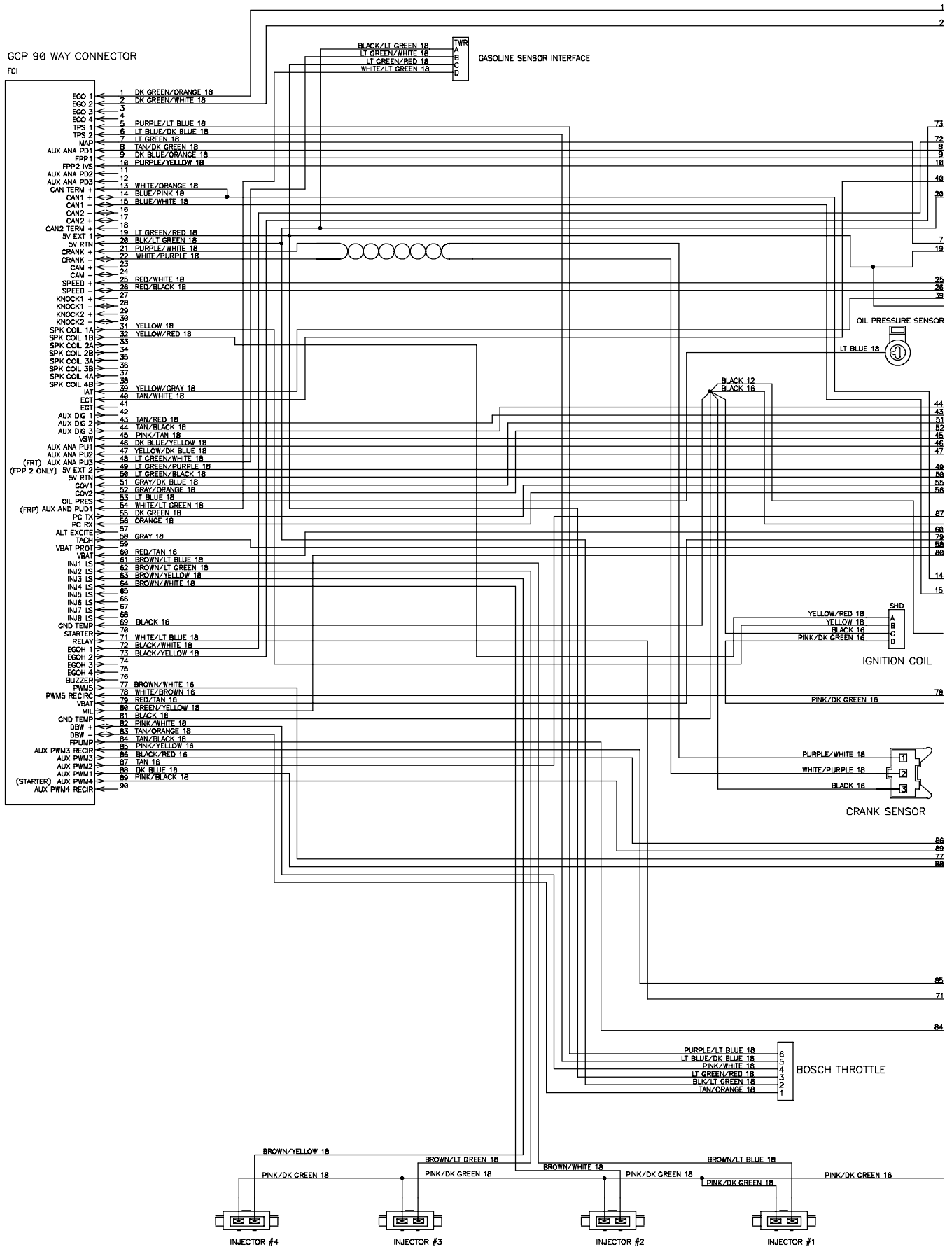

Gasoline Engine Harness Electrical Schematic (2 of 2)

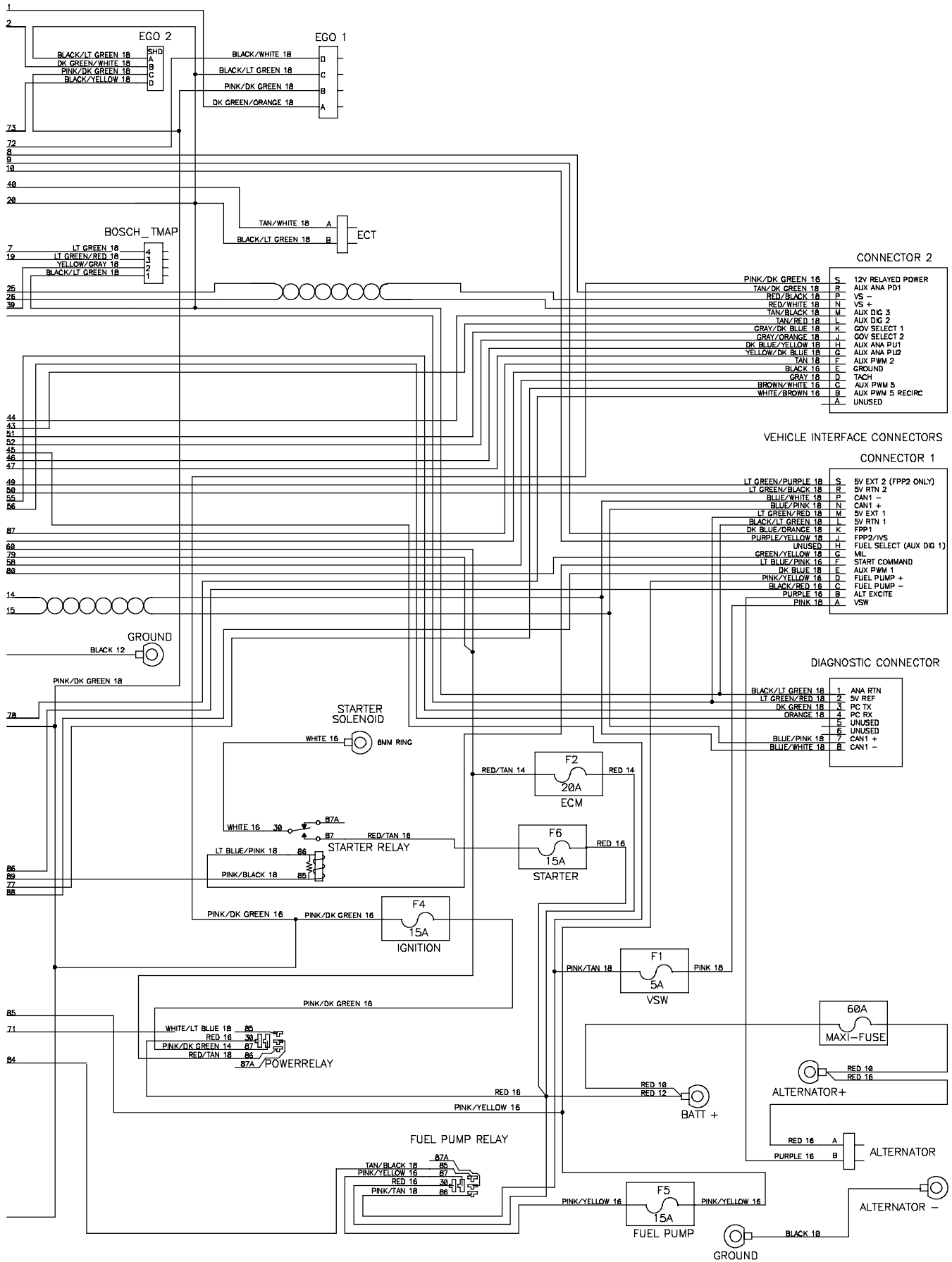

LPG Engine Harness Electrical Schematic (1 of 2)

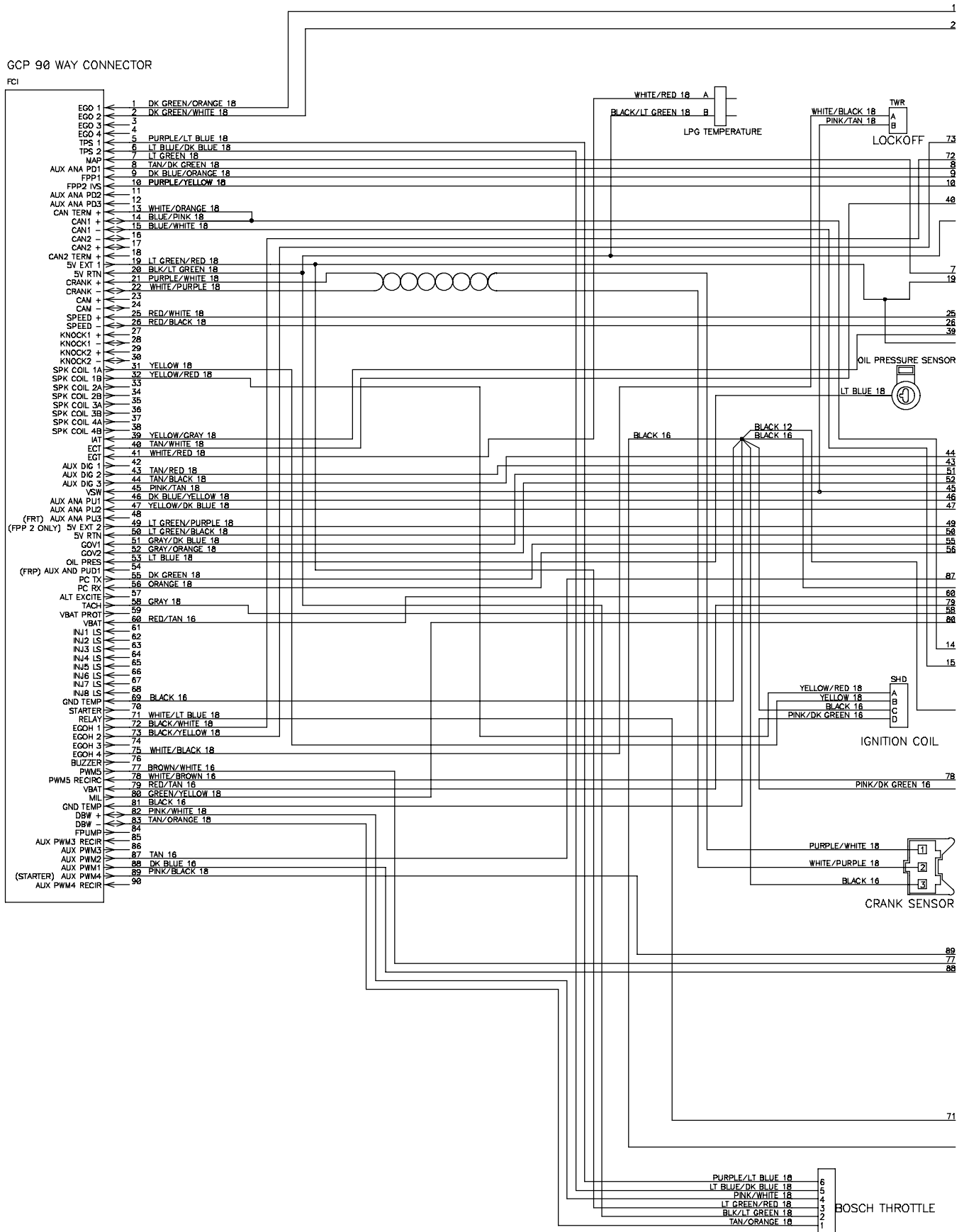

384990 - 354497

LPG Engine Harness Electrical Schematic (2 of 2)

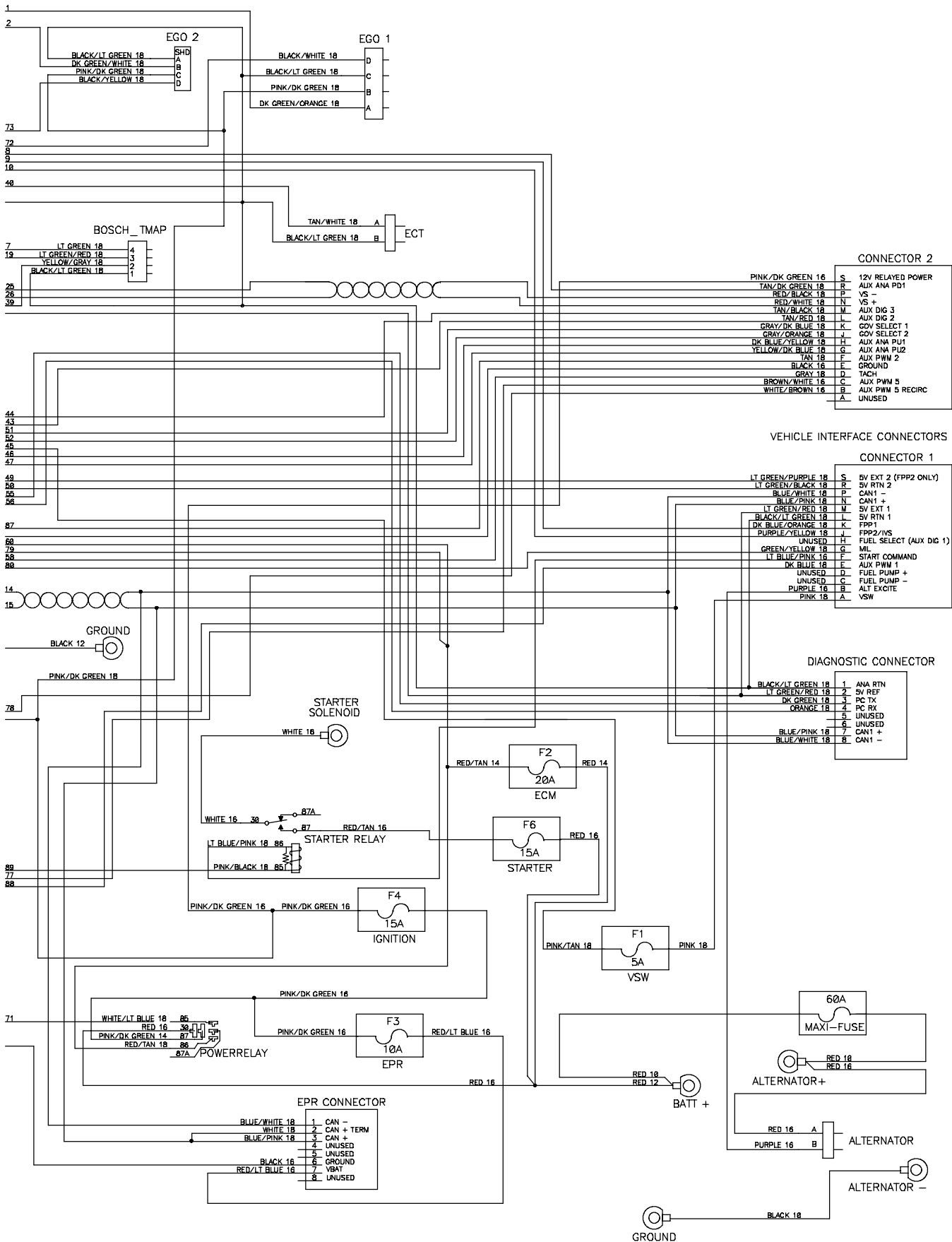

Diesel Engine Harness Electrical Schematic

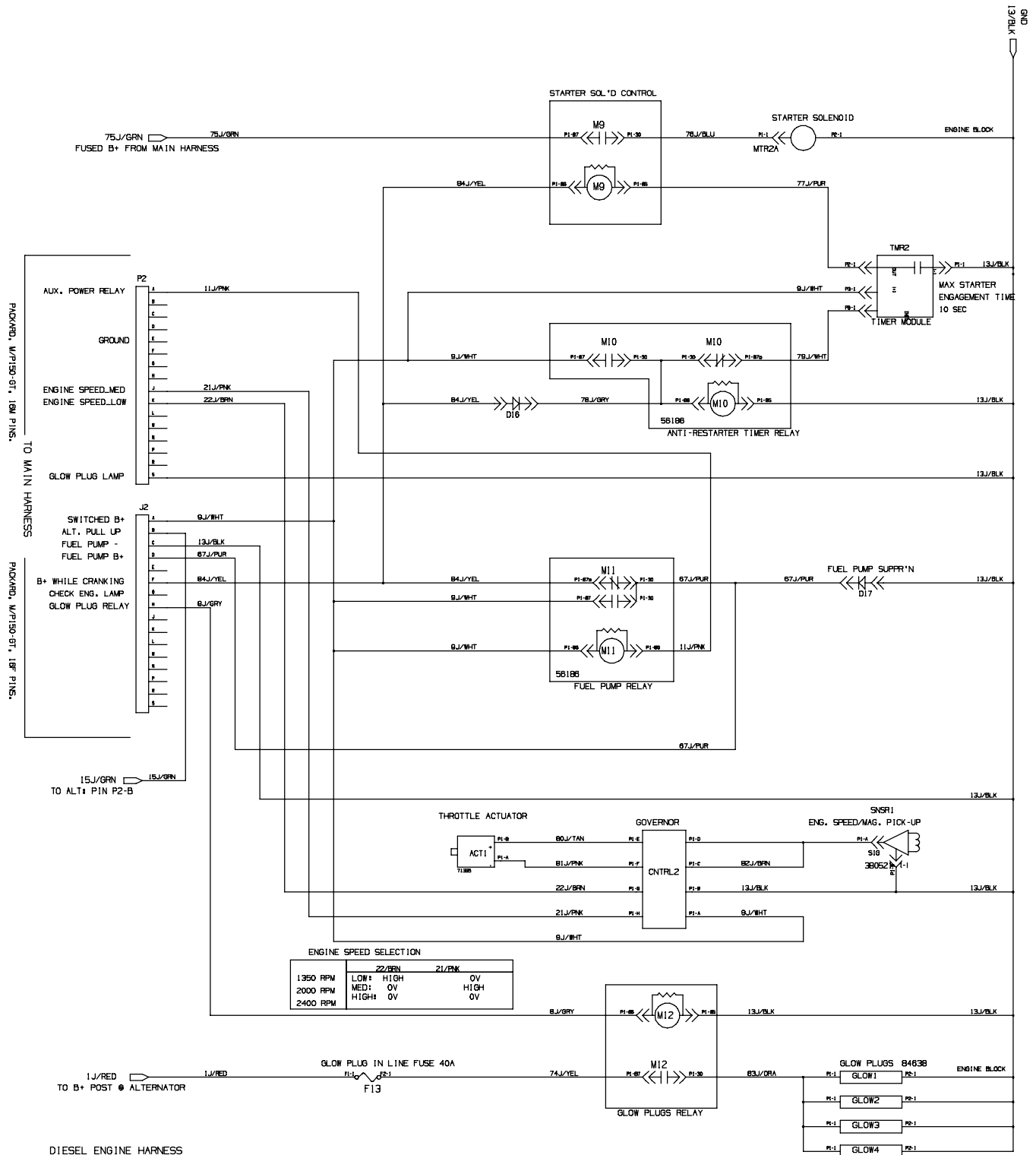

1029278- 354728

Cab Harness Electrical Schematic

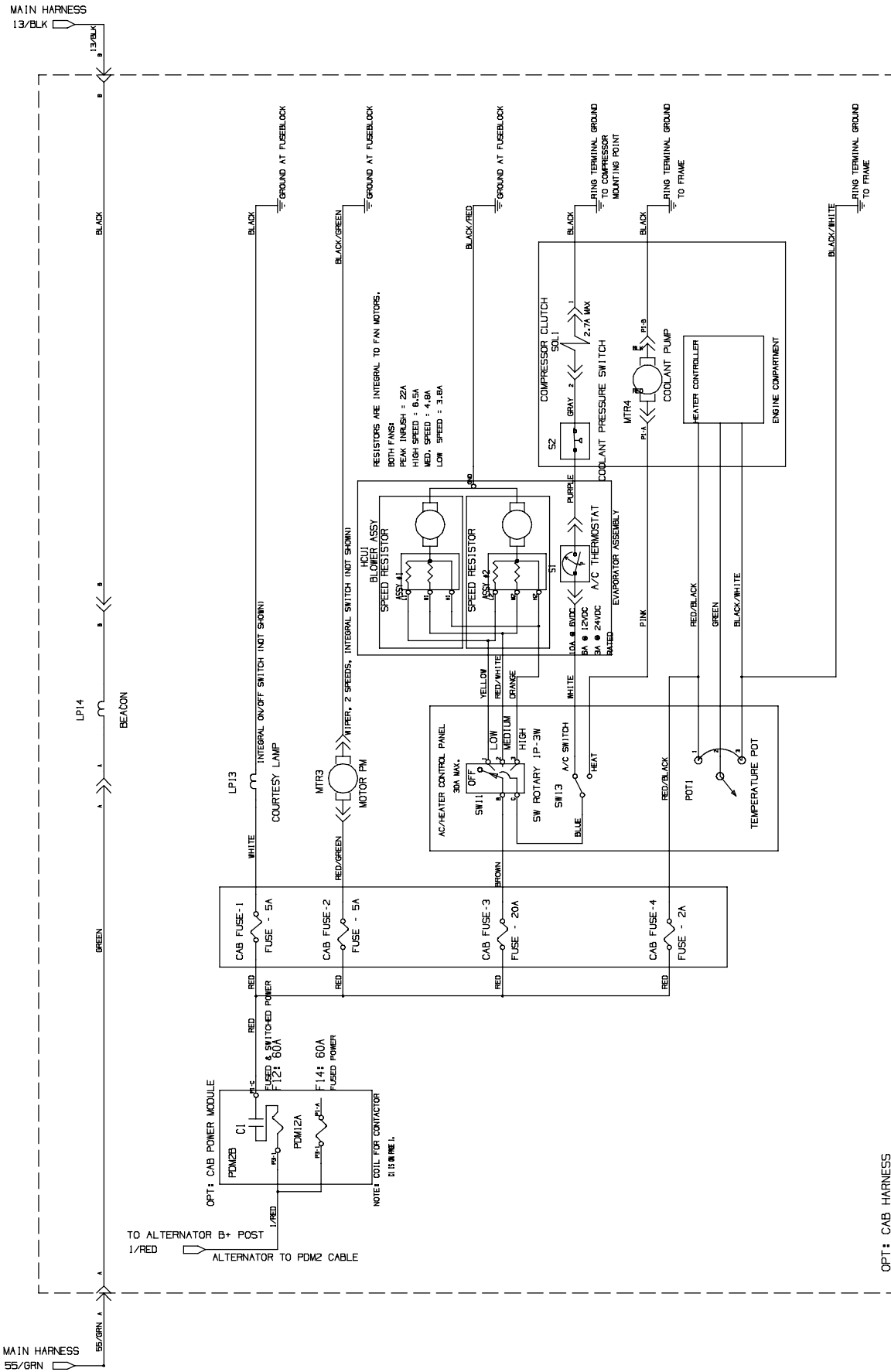

S30 Wire Harness Drawing (2 of 2)

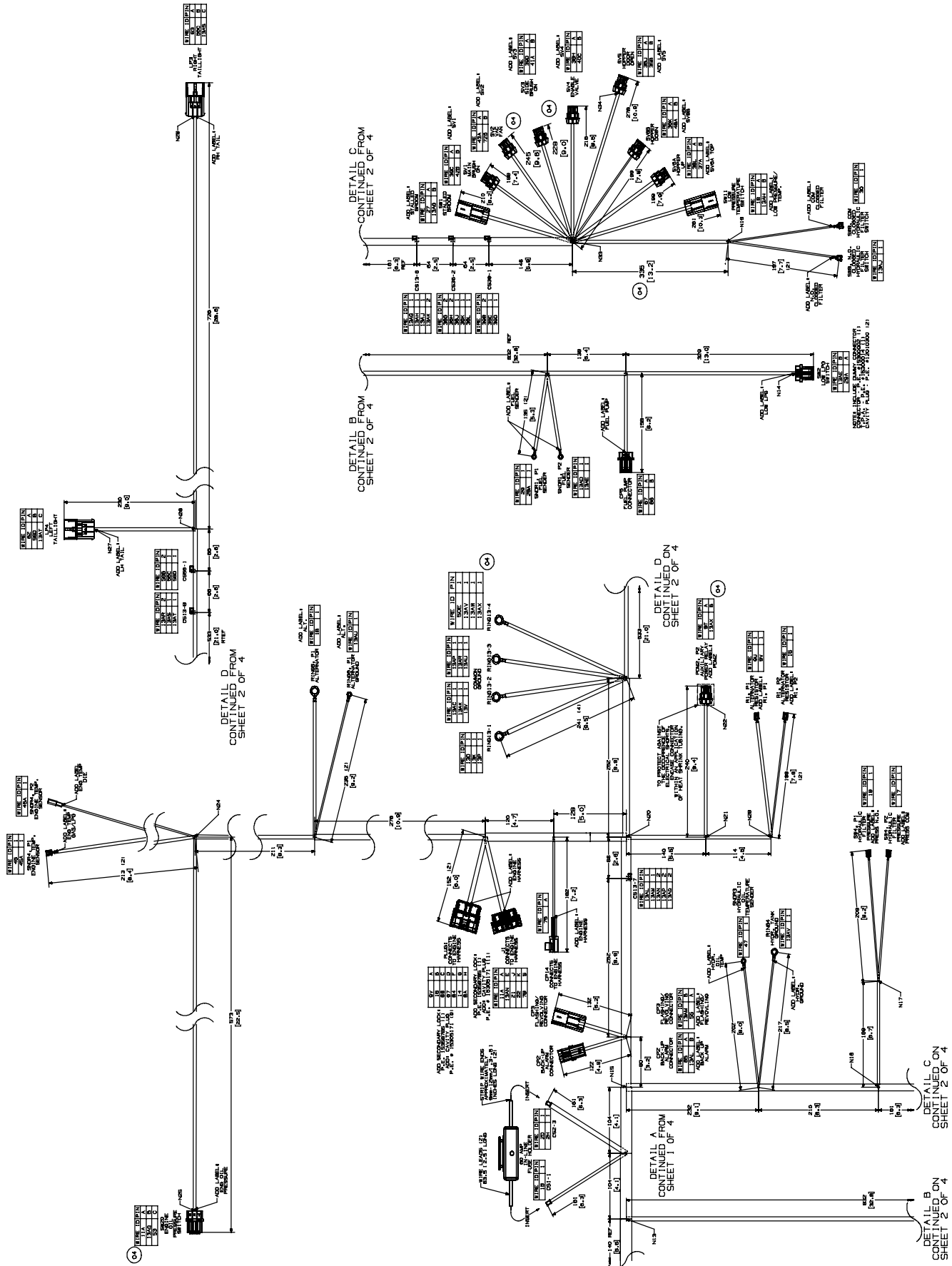

S30XP / S30X4 Wire Harness Drawing (2 of 3)

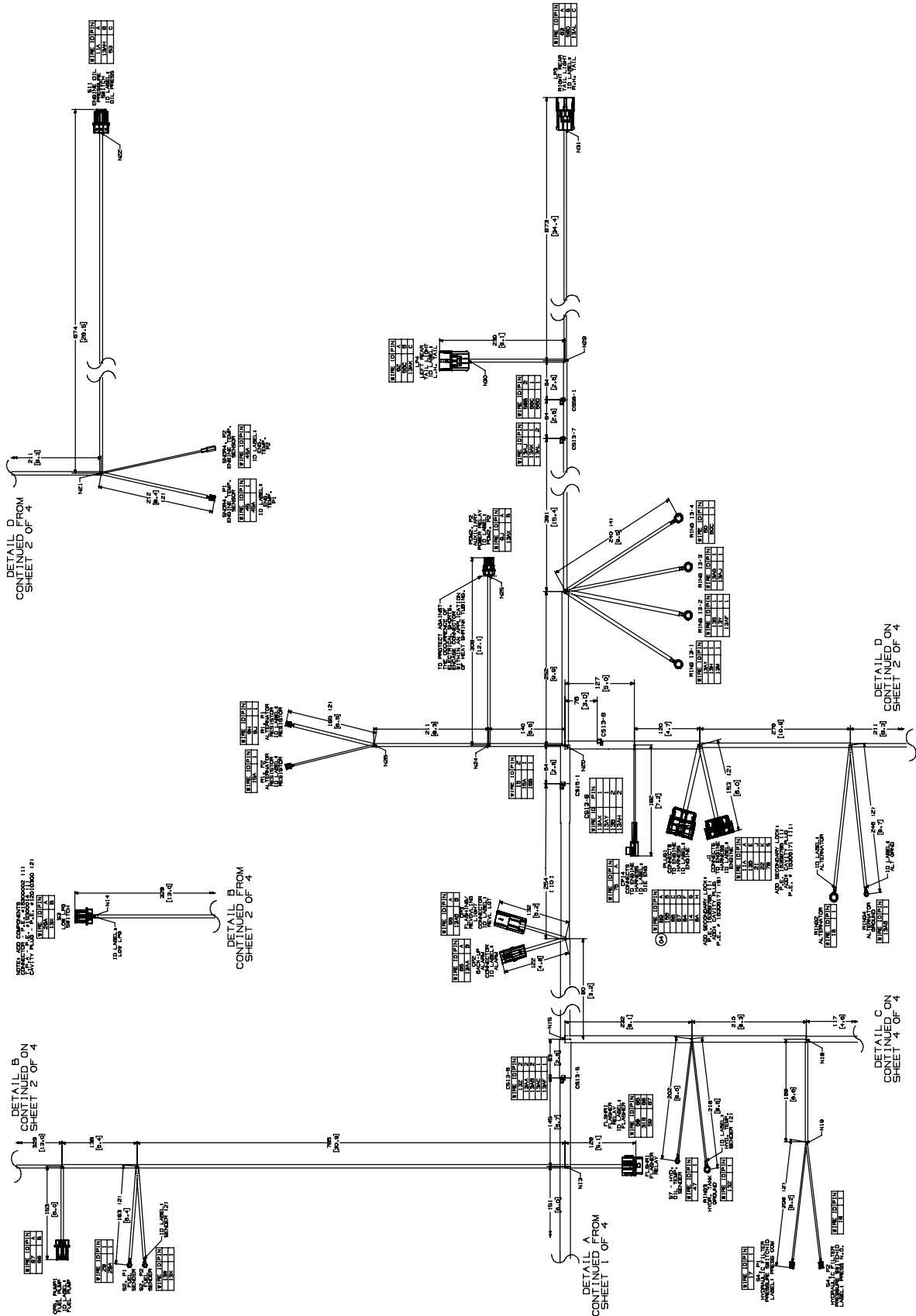

S30XP / S30X4 Wire Harness Drawing (3 of 3)

DETAIL C
CONTINUED FROM
SHEET 2 OF 4

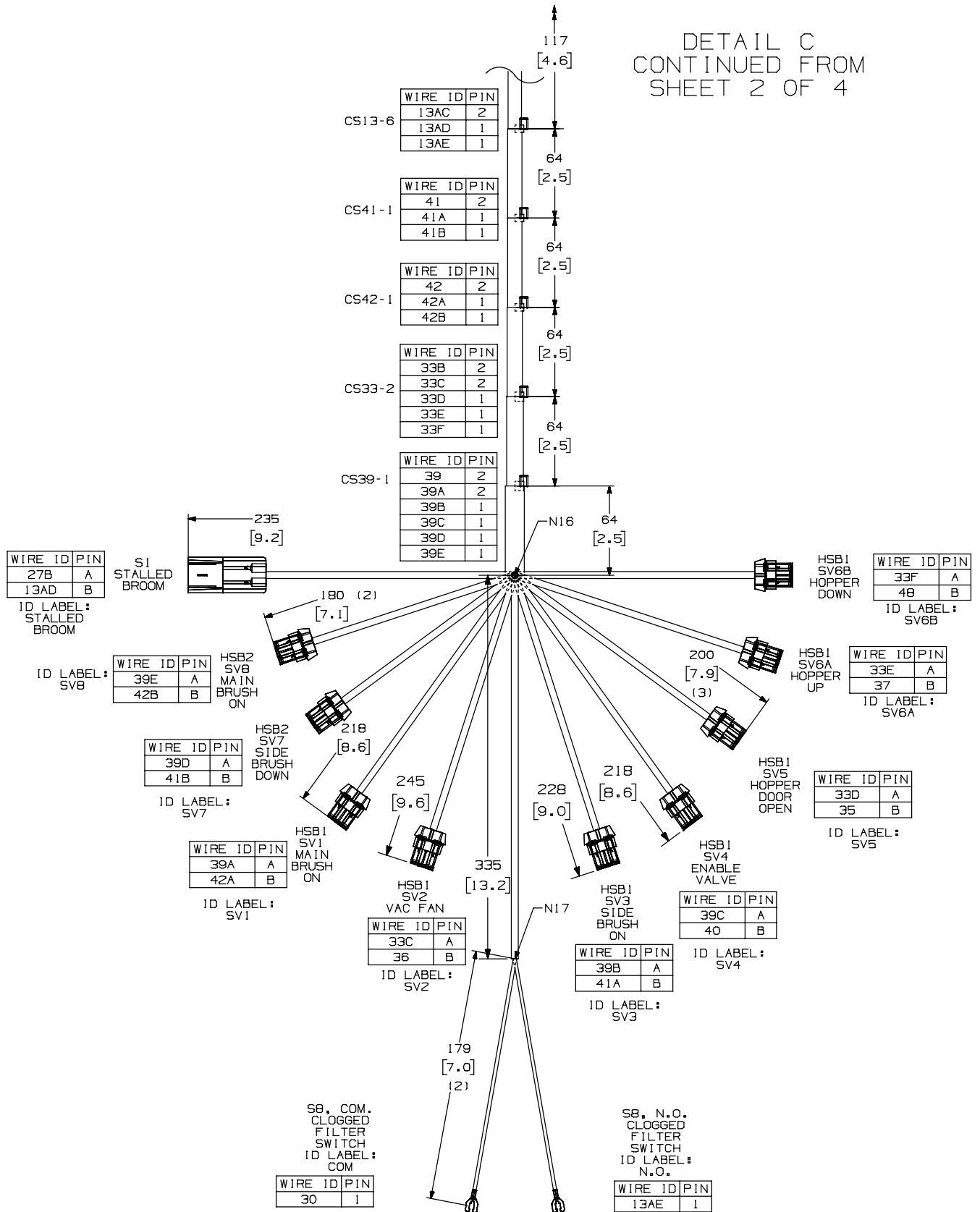

All Machines Hopper Wire Harness Drawing

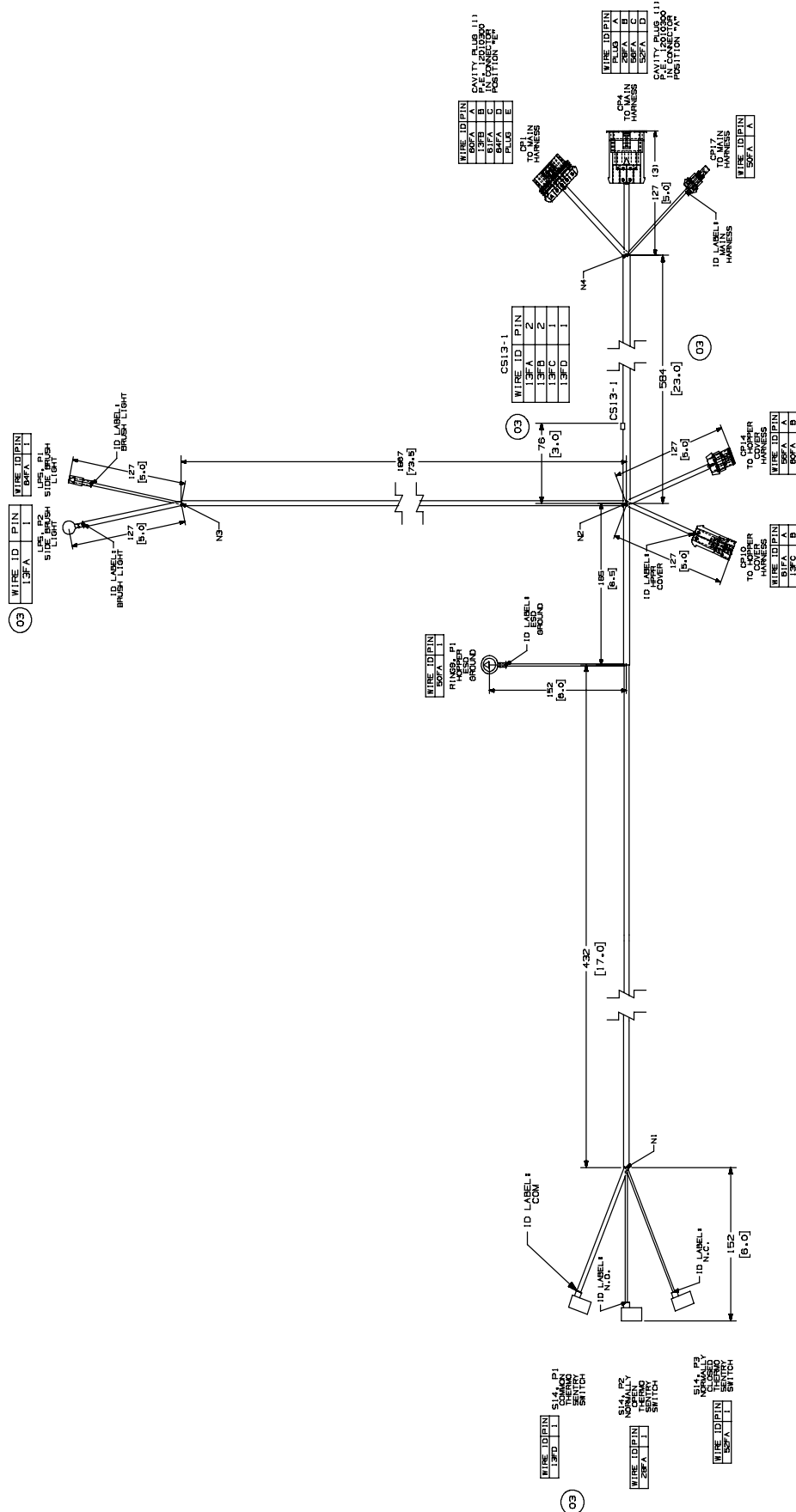

Key Switch Information (S30,S30XP,S30X4)

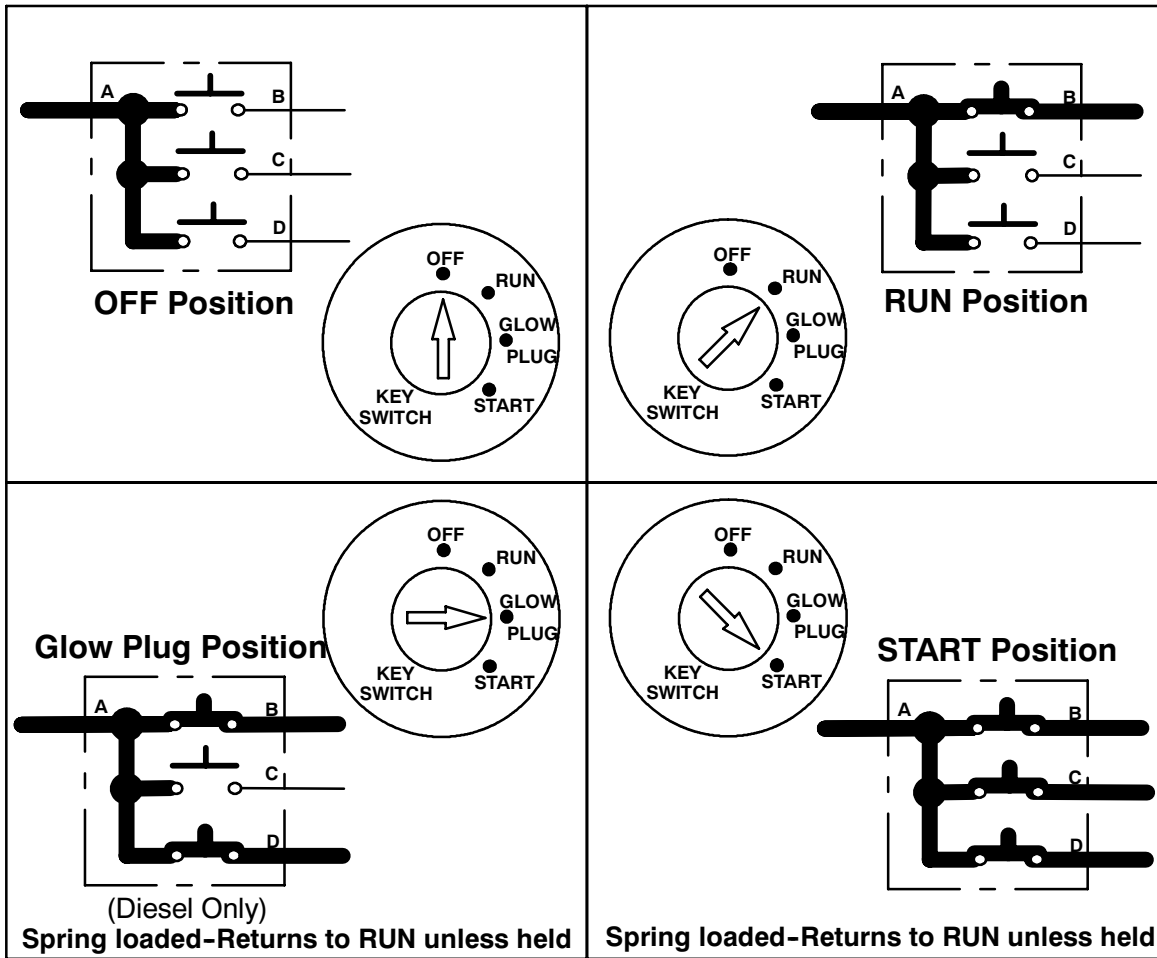

		Key Switch pin terminal			
		A	B	C	D
Key Switch position	OFF	No Connections			
	RUN	●—●			
	Glow Plug	●—●—●—●			
	START	●—●—●—●			

“●—●” Indicates a common connection

i Common connections in various switch positions should be less than 1 Ω

Key OFF Power Distribution (S30)

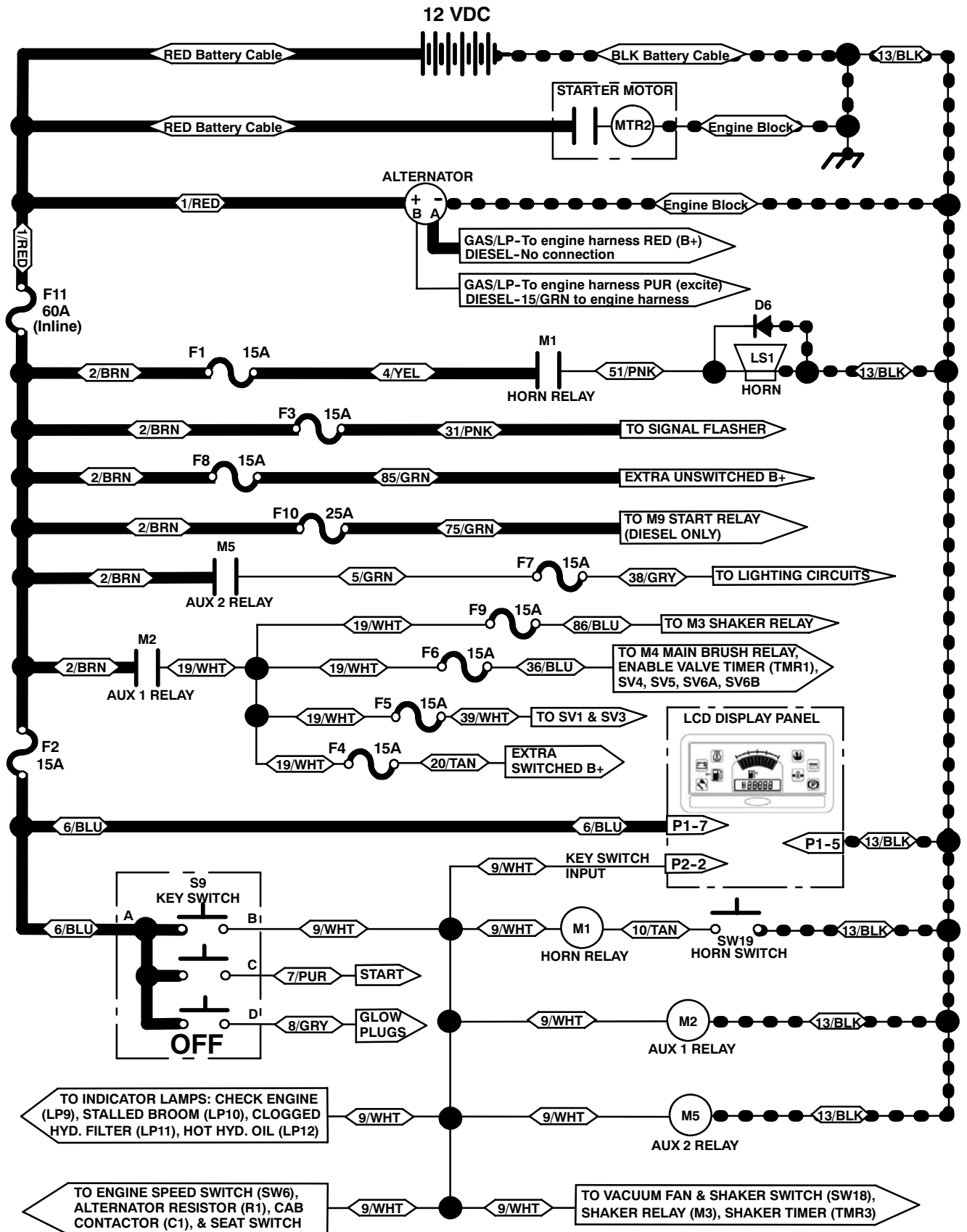

Key OFF Power Distribution (S30XP,S30X4)

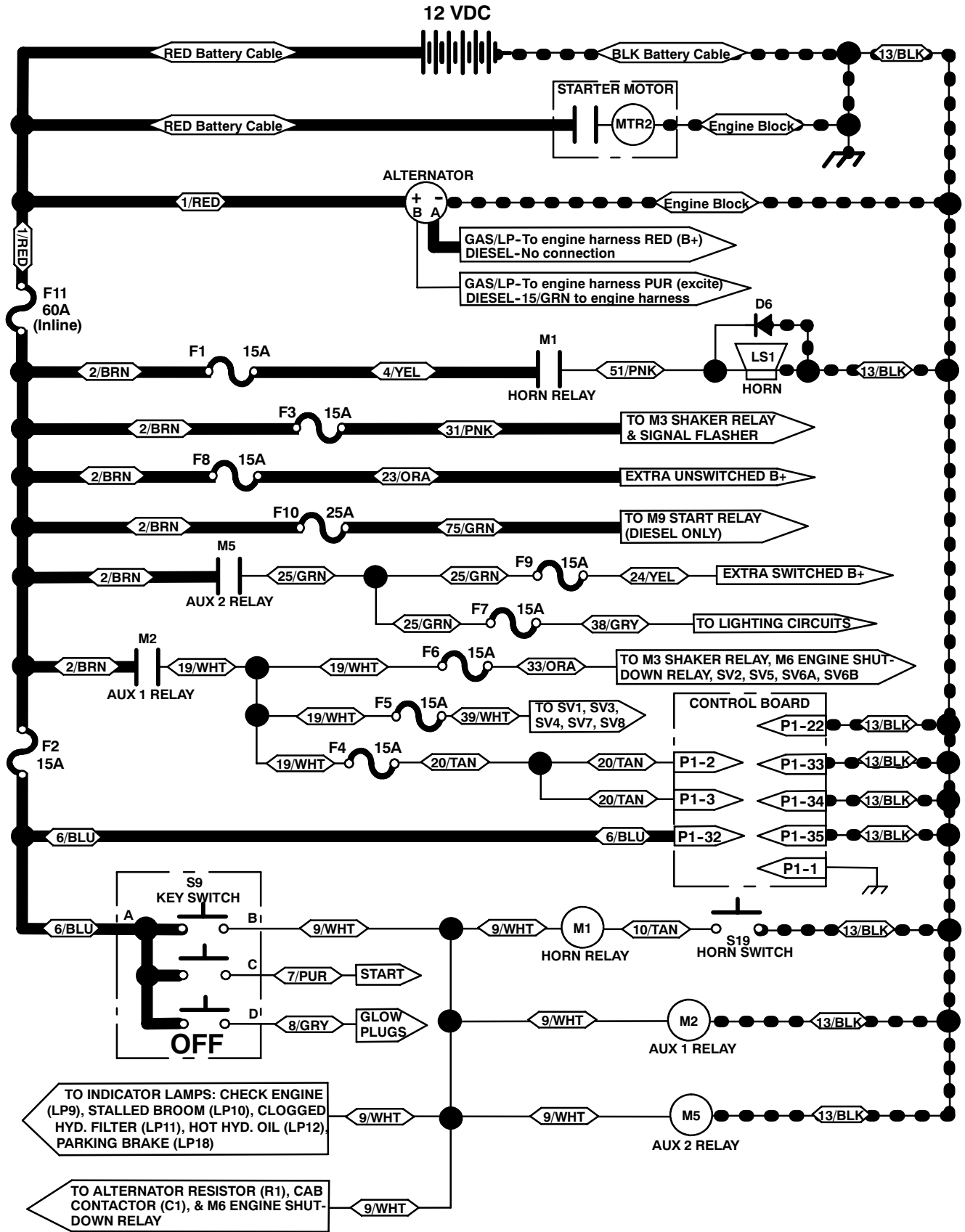

E

Key ON Power Distribution (S30)

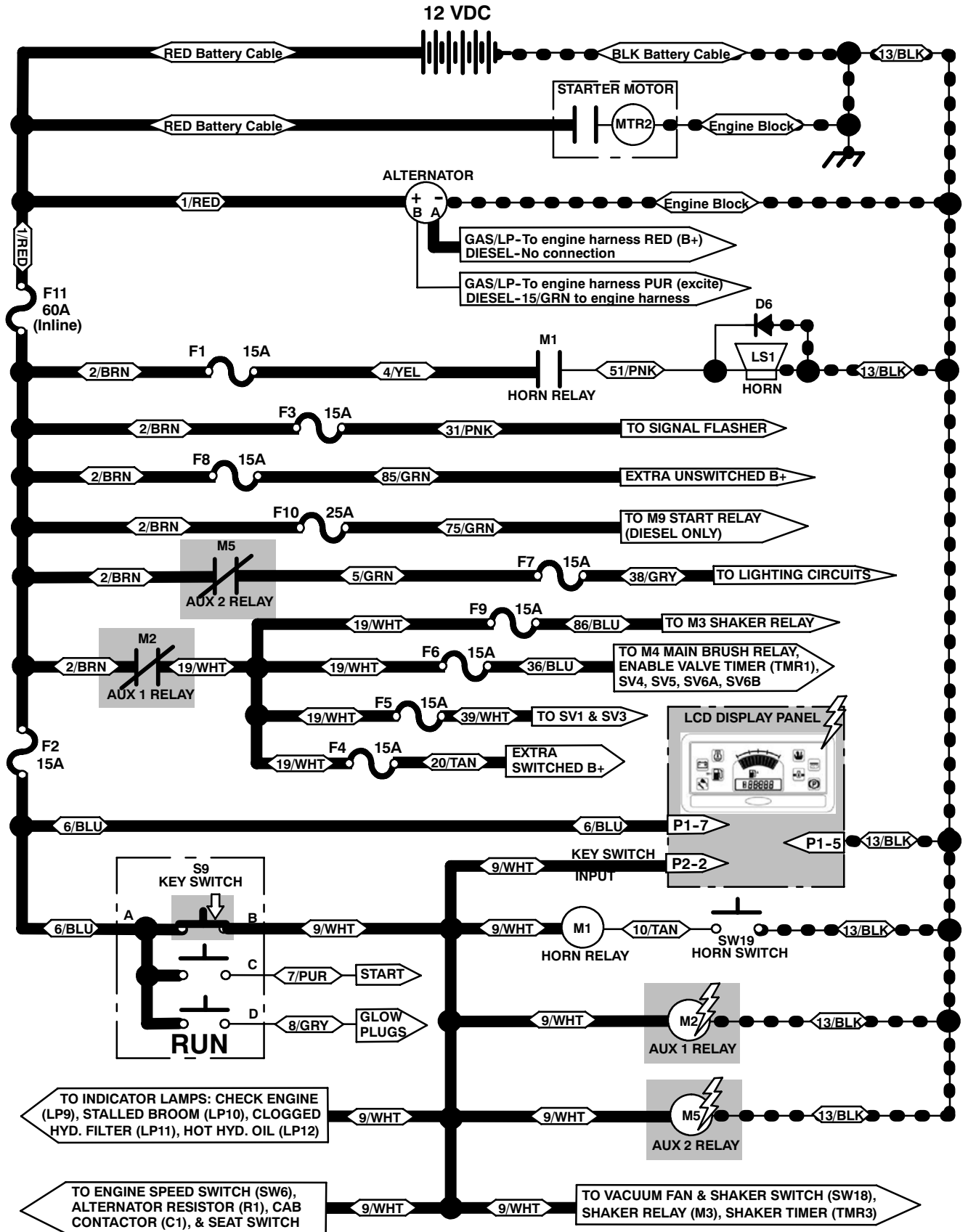

Key ON Power Distribution (S30XP,S30X4)

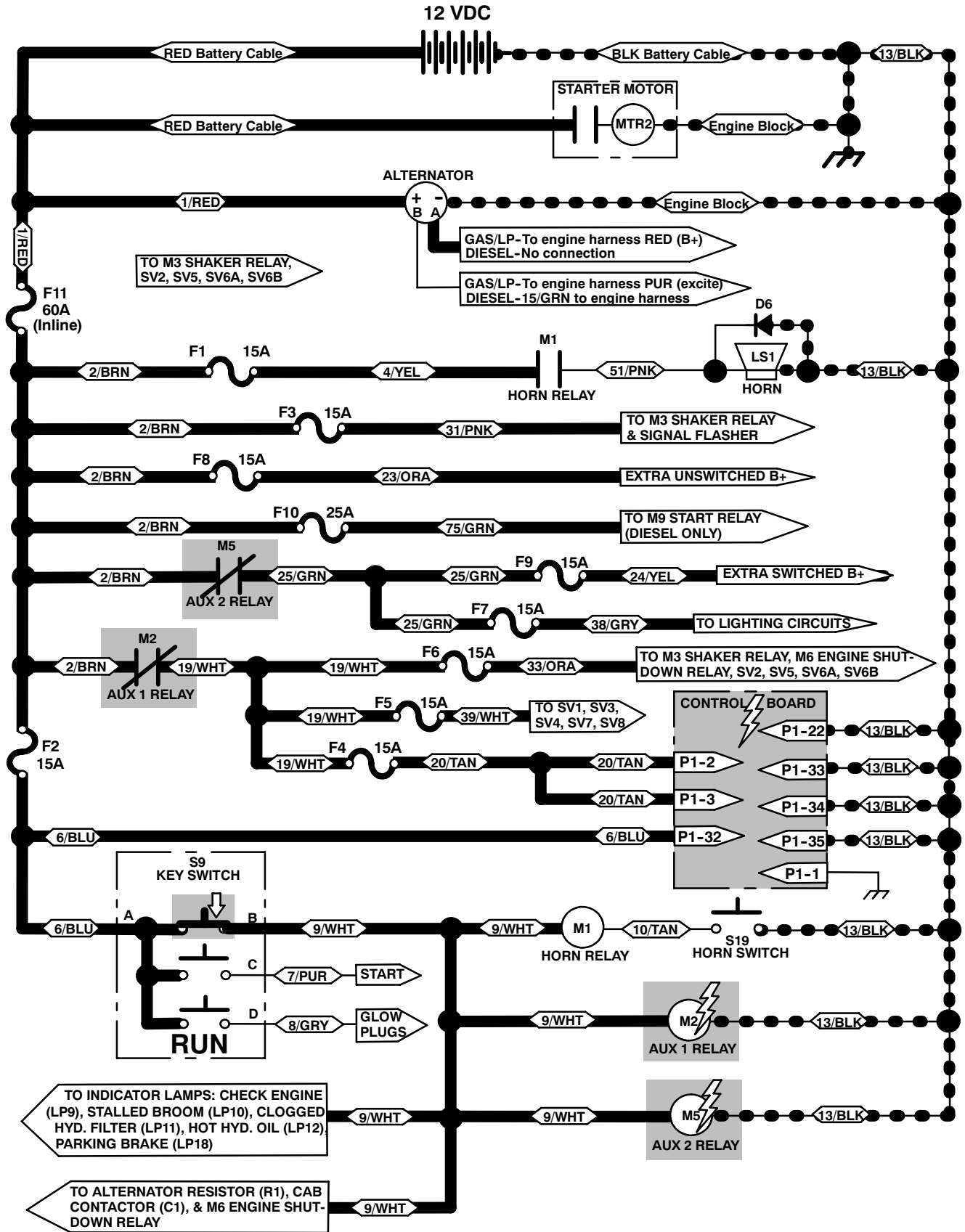

E

Main & Side Brushes ON (S30)

Conditions: Key ON (RUN), Main & Side Brushes Lowered. Hopper Down

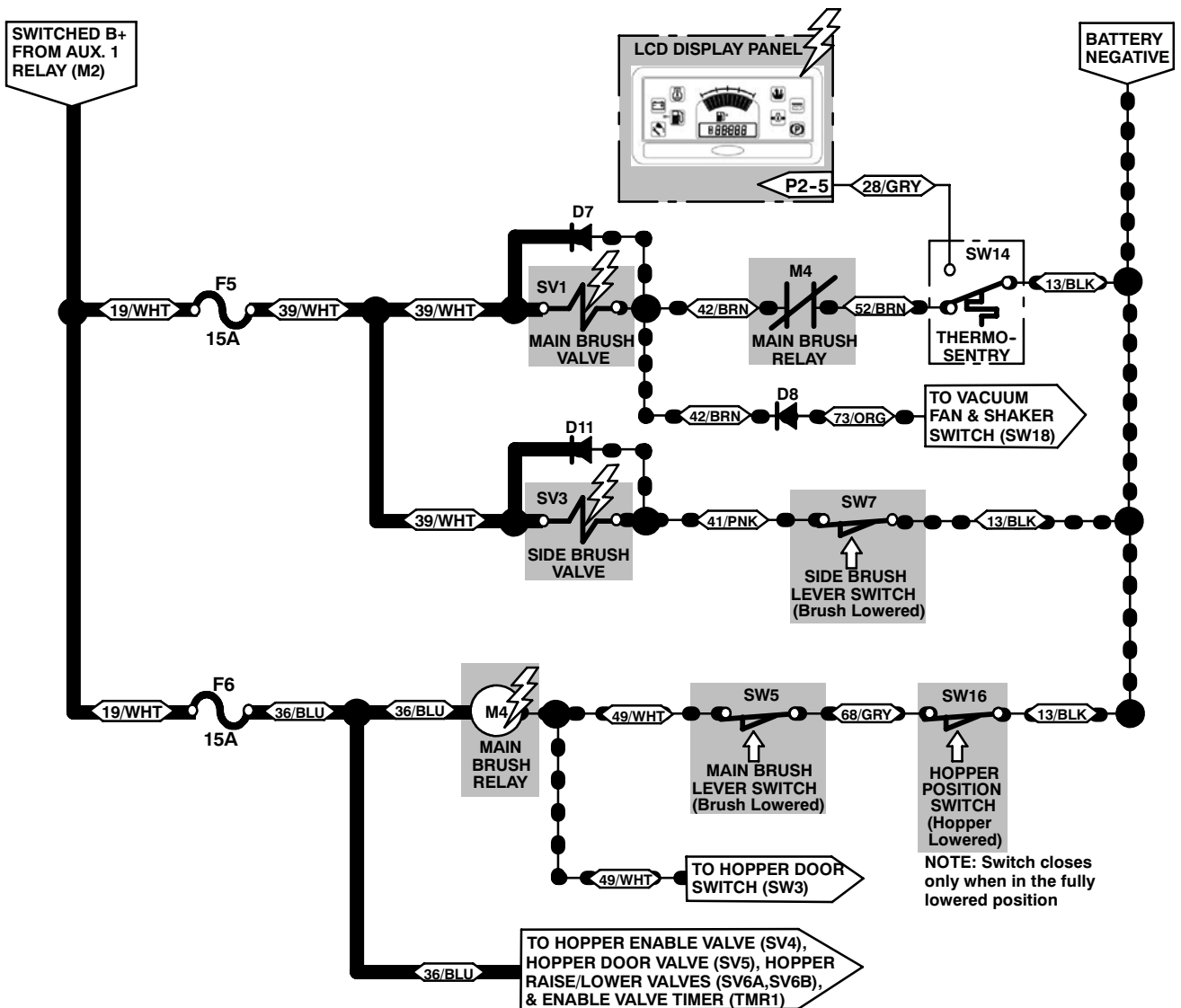

i Thermo-Sentry switch (SW14) is shown in the normal NON-activated position (13/BLK connected to 52/BRN). The switch is activated (13/BLK connected to 28/GRY) when the Hopper air temperature exceeds 71°C (160°F). The Hopper Fire indicator on the LCD panel will also illuminate when this switch is activated. When the temperature falls below 60°C (140°F), the switch will return to the NON-activated position, and the indicator light will turn OFF.

Main & Side Brushes ON (S30XP,S30X4)

Conditions: Key ON (RUN), Sweep System Activated, Side Brush(es) Activated. Hopper Down

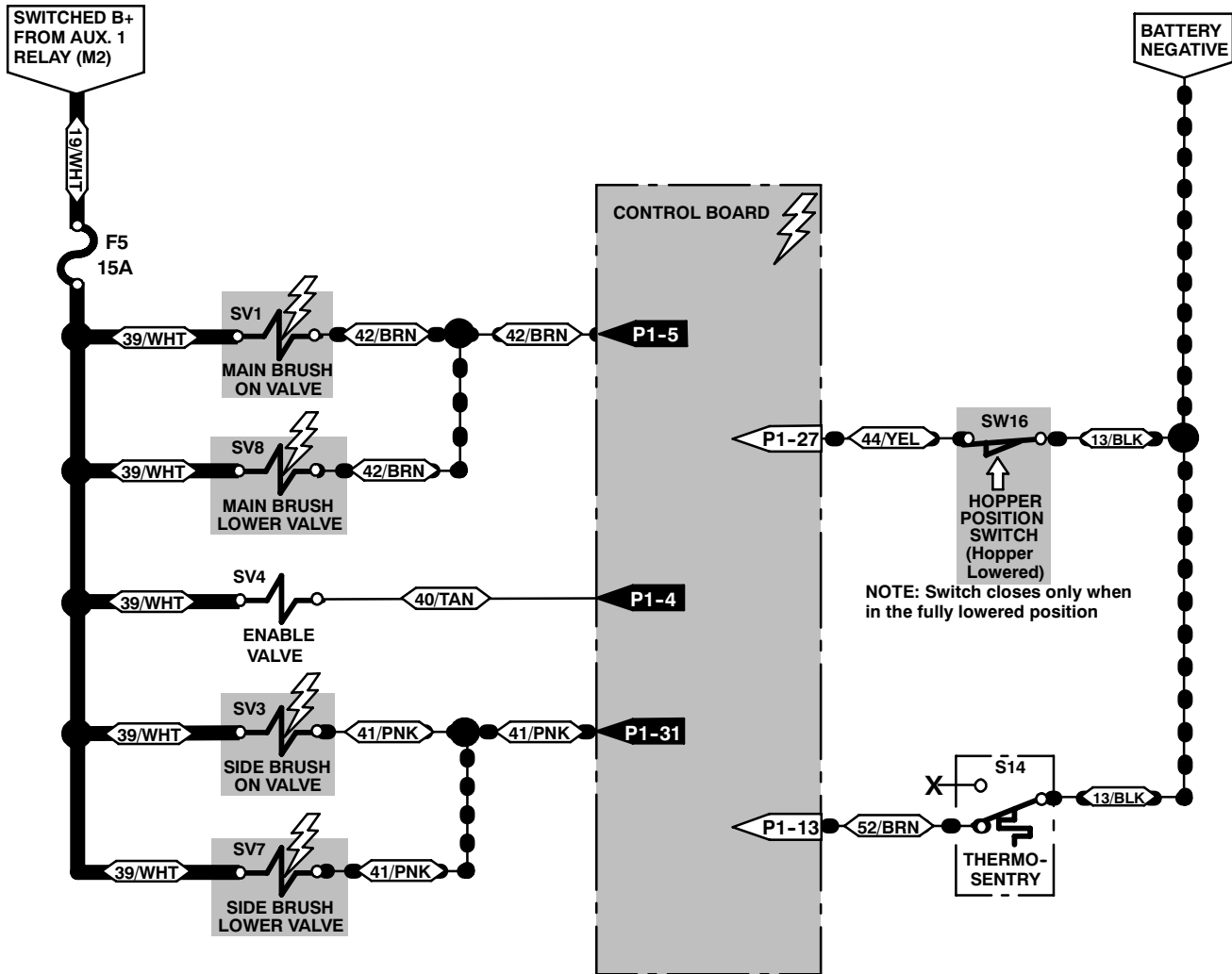

i Thermo-Sentry switch (S14) is shown in the normal NON-activated position (13/BLK connected to 52/BRN). The switch is activated (13/BLK connected to 28/GRY) when the Hopper air temperature exceeds 71°C (160°F). The Hopper Fire indicator on the control panel will also illuminate when this switch is activated. When the temperature falls below 60°C (140°F), the switch will return to the NON-activated position, and the indicator light will turn OFF.

E

Vacuum Fan ON (S30)

Conditions: Key ON (RUN), Main Brush Lowered. Hopper Down

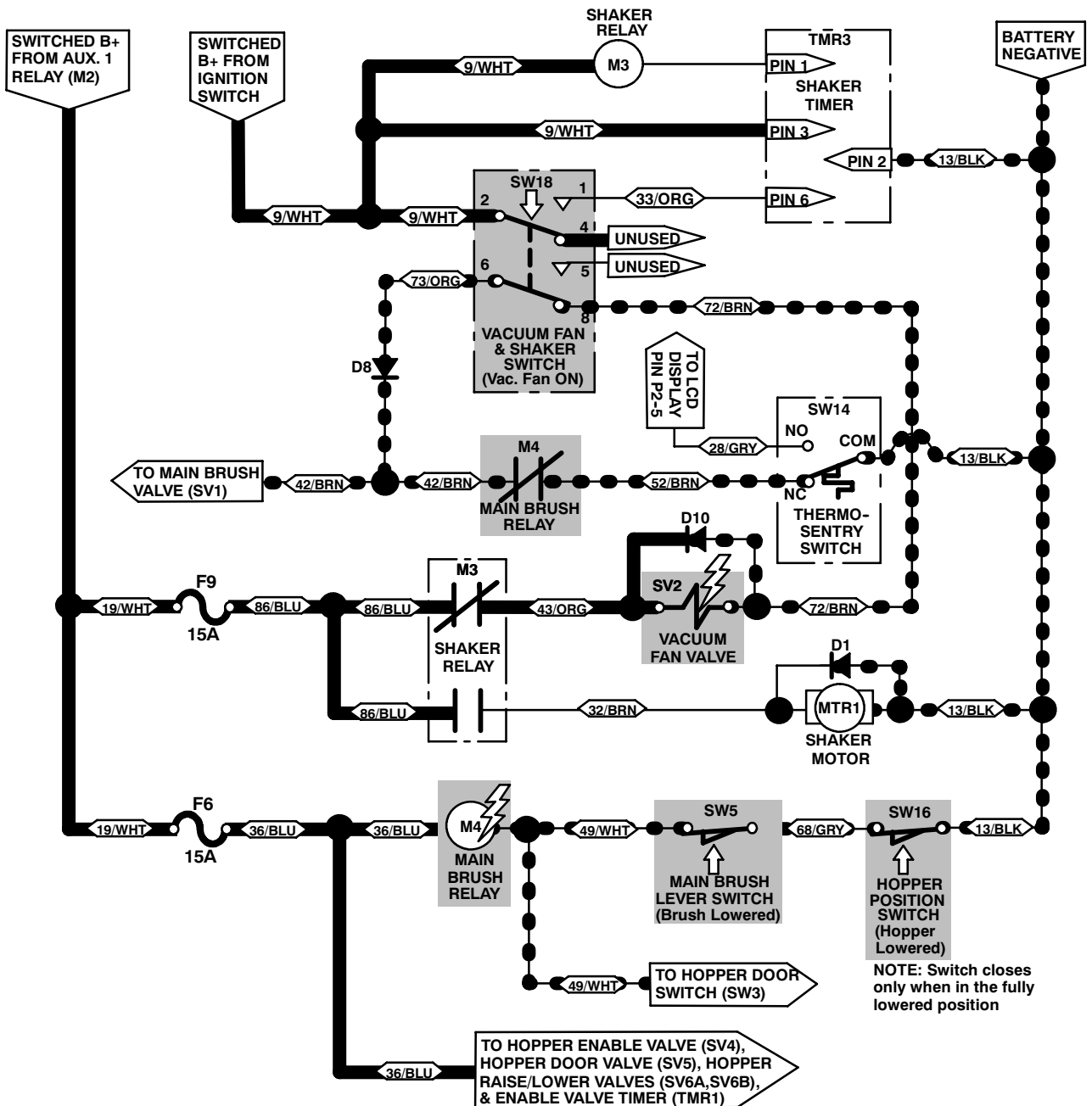

- i** - The Thermo-Sentry switch (SW14) is shown in the normal NON-activated position (13/BLK connected to 52/BRN). The switch is activated (13/BLK connected to 28/GRY) when the Hopper air temperature exceeds 71°C (160°F). The Hopper Fire indicator on the LCD panel will also illuminate when this switch is activated. When the temperature falls below 60°C (140°F), the switch will return to the NON-activated position, and the indicator light will turn OFF.
- The Vacuum Fan & Shaker Switch (SW18) is a 3-position switch. This drawing shows the switch in the Vacuum Fan position, which will remain in this position until the operator selects the OFF (center) position, or performs a Shaker cycle (momentary position).

Vacuum Fan ON (S30XP,S30X4)

Conditions: Key ON (RUN), Sweep System Activated, Vacuum System Activated. Hopper Down

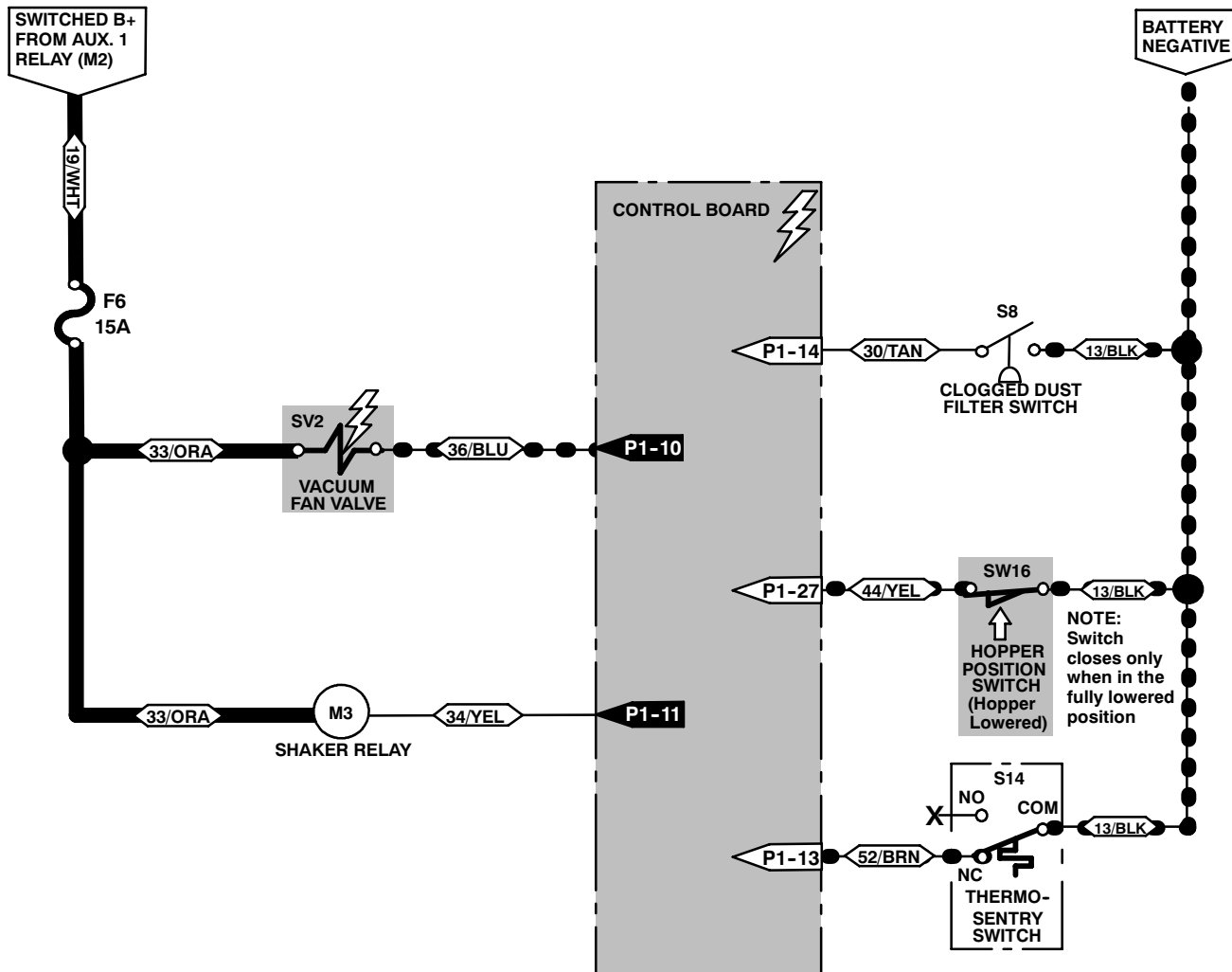

- Thermo-Sentry switch (S14) is shown in the normal NON-activated position (13/BLK connected to 52/BRN). The switch is activated (13/BLK NOT connected to 52/BRN) when the Hopper air temperature exceeds 71°C (160°F). The LCD screen on the control panel will also show "F5: HOPPER FIRE" when this switch is activated, all sweeping functions will turn OFF and the hopper door will close. When the temperature falls below 60°C (140°F), the switch will return to the NON-activated position.

- Clogged Dust Filter Switch (S8) is shown in the normal NON-activated position (30/TAN NOT connected to 13/BLK), and will close when the dust filter becomes clogged. The switch closes when the negative pressure reaches 28 cm (11 in) of water lift (vacuum). The LCD screen on the control panel will also show "F4: SHAKER FILTER" when this switch is closed.

Filter Shaker ON (S30)

Conditions: Key ON (RUN), Hopper Down

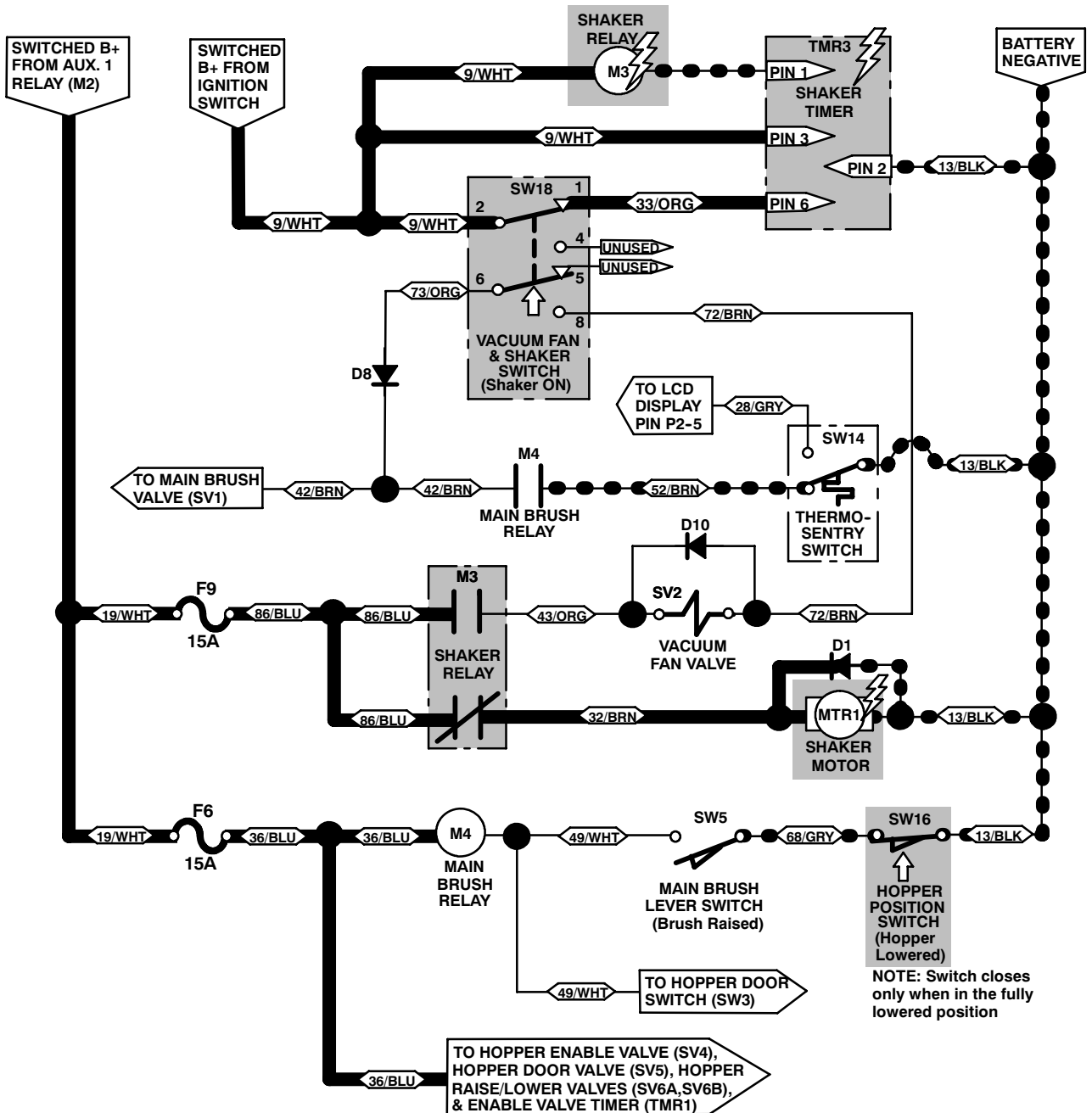

- i** - The Vacuum Fan & Shaker Switch (SW18) is a 3-position switch. This drawing shows the switch in the Shaker position, which must be held, and then released (momentary switch) to initiate a Shaker cycle. When released, the switch will return to the center OFF position.
- When B+ is momentarily applied to Pin 6 of the Shaker Timer (TMR3), a 30 second Shaker cycle begins, applying Battery Negative to Pin 1 of TMR3.

Filter Shaker ON (S30XP,S30X4)

Conditions: Key ON (RUN), Shaker System Activated

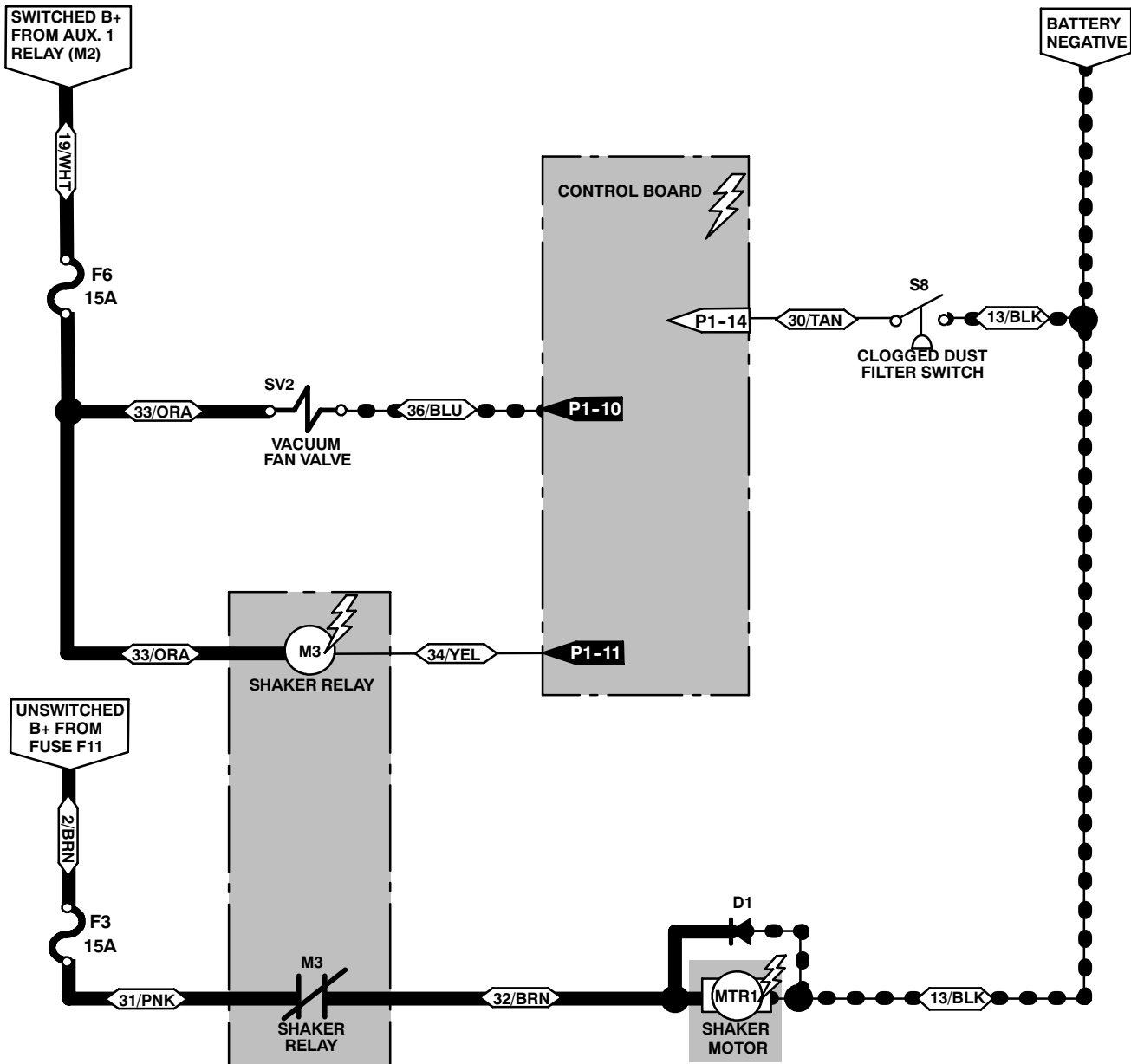

i - When activated, the Shaker System will run for 30 seconds. The Shaker System is automatically activated when turning the sweeping system OFF, or can be activated anytime by pressing the Shaker button. Pressing the Shaker button during sweeping will turn OFF the Vacuum Fan during the Shaker cycle. The Shaker System is the only sweeping related function that can be activated with the Hopper in the raised position.

- Clogged Dust Filter Switch (S8) is shown in the normal NON-activated position (30/TAN NOT connected to 13/BLK), and will close when the dust filter becomes clogged. The switch closes when the negative pressure reaches 28 cm (11 in) of water lift (vacuum). The LCD screen on the control panel will also show "F4: SHAKER FILTER" when this switch is closed.

Hopper Lift (S30)

Conditions: Key ON (RUN), Hopper Door Closed

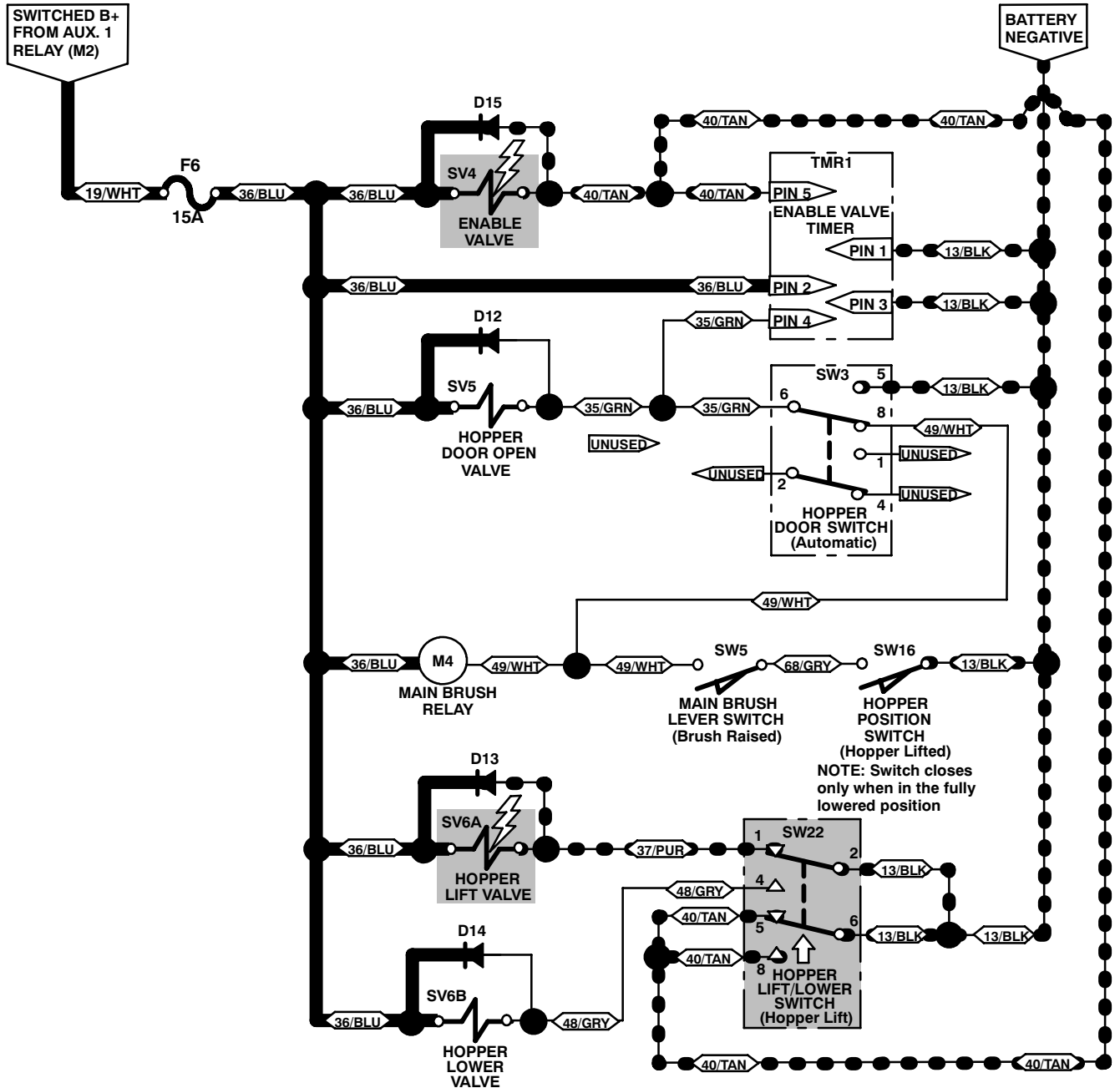

- i** - The Hopper Lift/Lower Switch (SW22) is a 3-position switch. This drawing shows the switch in the Hopper Lift position, which must be held (momentary switch) while the Hopper is being lifted. When released, the switch will return to the center OFF position, and the Hopper will remain in the current position.
- Enable Valve (SV4) must be energized when Lifting or Lowering the Hopper, or when Opening or Closing the Hopper Door. To open the Hopper Door, the Enable Valve (SV4) and the Hopper Door Open Valve (SV5) must be energized. To close the Hopper Door, ONLY the Enable Valve (SV4) must be energized (SV5 is OFF).
- The Enable Valve Timer (TMR1) energizes the Enable Valve (SV4) for 6 seconds when triggered. Triggering of TMR1 occurs when the Hopper Door Open Valve (SV5) is turned ON or OFF, and is input on Pin 4 of TMR1.

Hopper Lift (S30XP,S30X4)

Conditions: Key ON (RUN)

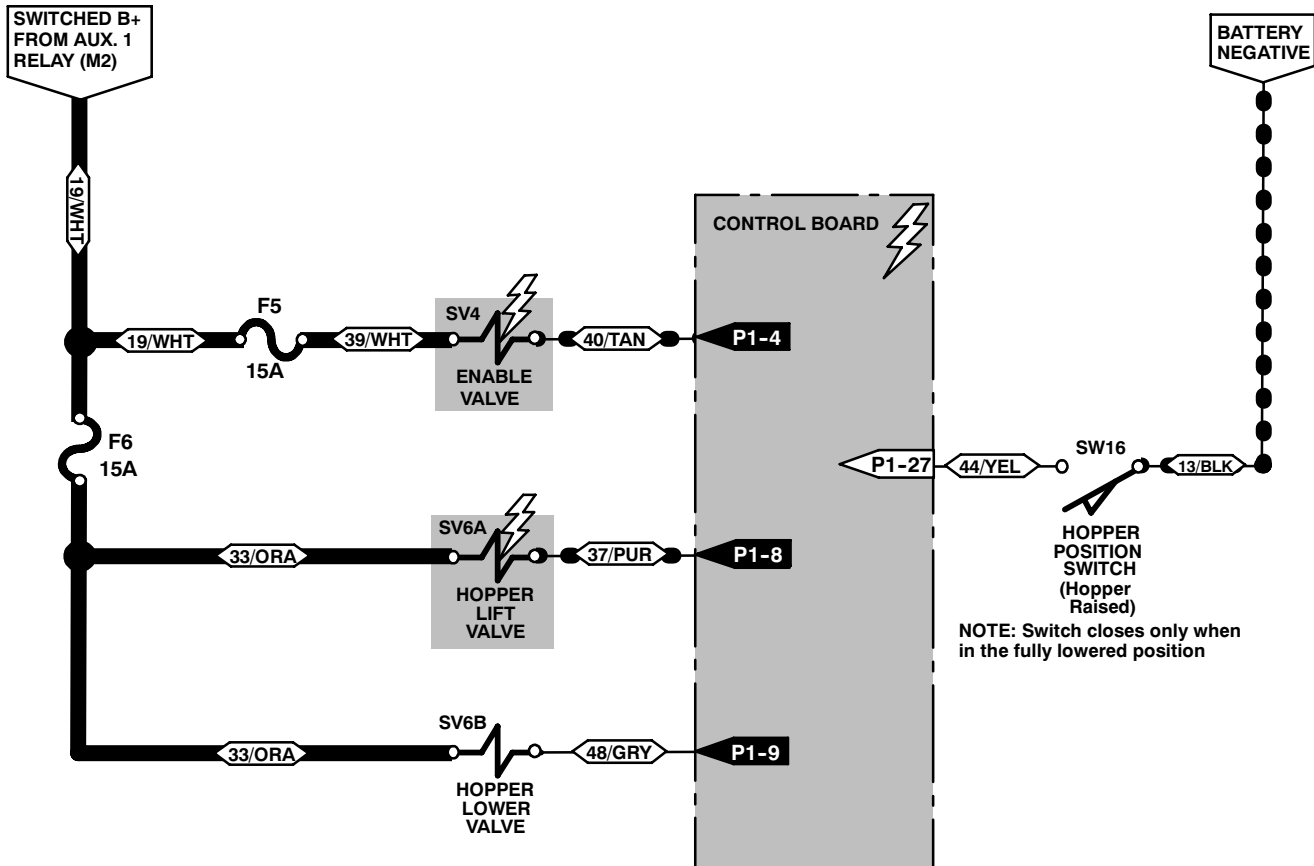

i - The Enable Valve (SV4) is ON ONLY during the following Hopper related functions:

- 1) Hopper Lift
- 2) Hopper Lower
- 3) Hopper Door Open
- 4) Hopper Door Close

- Lifting the Hopper or closing the Hopper Door turns OFF all sweeping related functions when the One-Step system is ON.

Hopper Lower (S30)

Conditions: Key ON (RUN), Hopper Door Closed

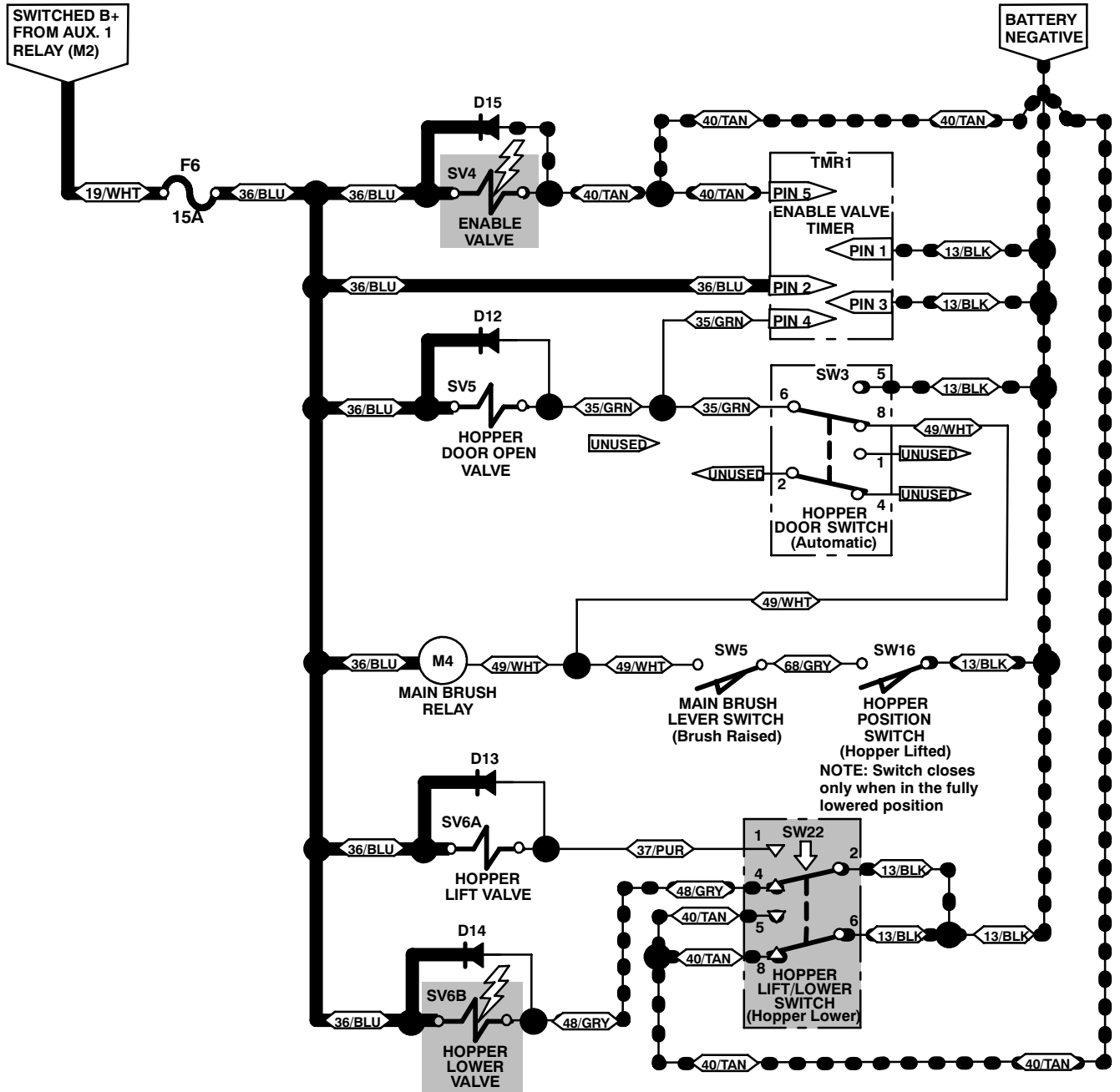

- i** - The Hopper Lift/Lower Switch (SW22) is a 3-position switch. This drawing shows the switch in the Hopper Lower position, which must be held (momentary switch) while the Hopper is being lowered. When released, the switch will return to the center OFF position, and the Hopper will remain in the current position.
- Enable Valve (SV4) must be energized when Lifting or Lowering the Hopper, or when Opening or Closing the Hopper Door. To open the Hopper Door, the Enable Valve (SV4) and the Hopper Door Open Valve (SV5) must be energized. To close the Hopper Door, ONLY the Enable Valve (SV4) must be energized (SV5 is OFF).
- The Enable Valve Timer (TMR1) energizes the Enable Valve (SV4) for 6 seconds when triggered. Triggering of TMR1 occurs when the Hopper Door Open Valve (SV5) is turned ON or OFF, and is input on Pin 4 of TMR1.

Hopper Lower (S30XP,S30X4)

Conditions: Key ON (RUN)

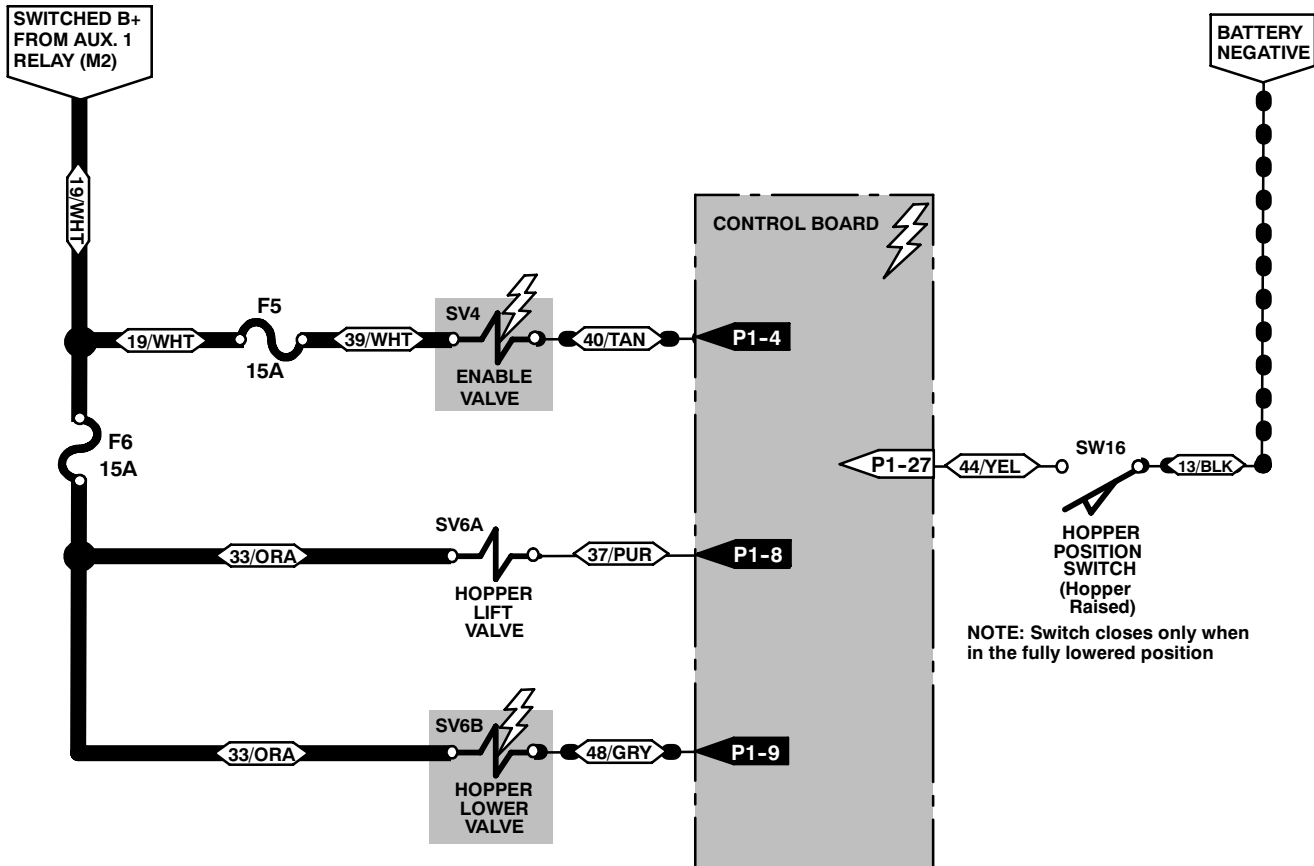

i - The Enable Valve (SV4) is ON ONLY during the following Hopper related functions:

- 1) Hopper Lift
- 2) Hopper Lower
- 3) Hopper Door Open
- 4) Hopper Door Close

- Lifting the Hopper or closing the Hopper Door turns OFF all sweeping related functions when the One-Step system is ON.

E

Hopper Door Open - Automatic (S30)

Conditions: Key ON (RUN), Main Brush Lowered, Hopper Down

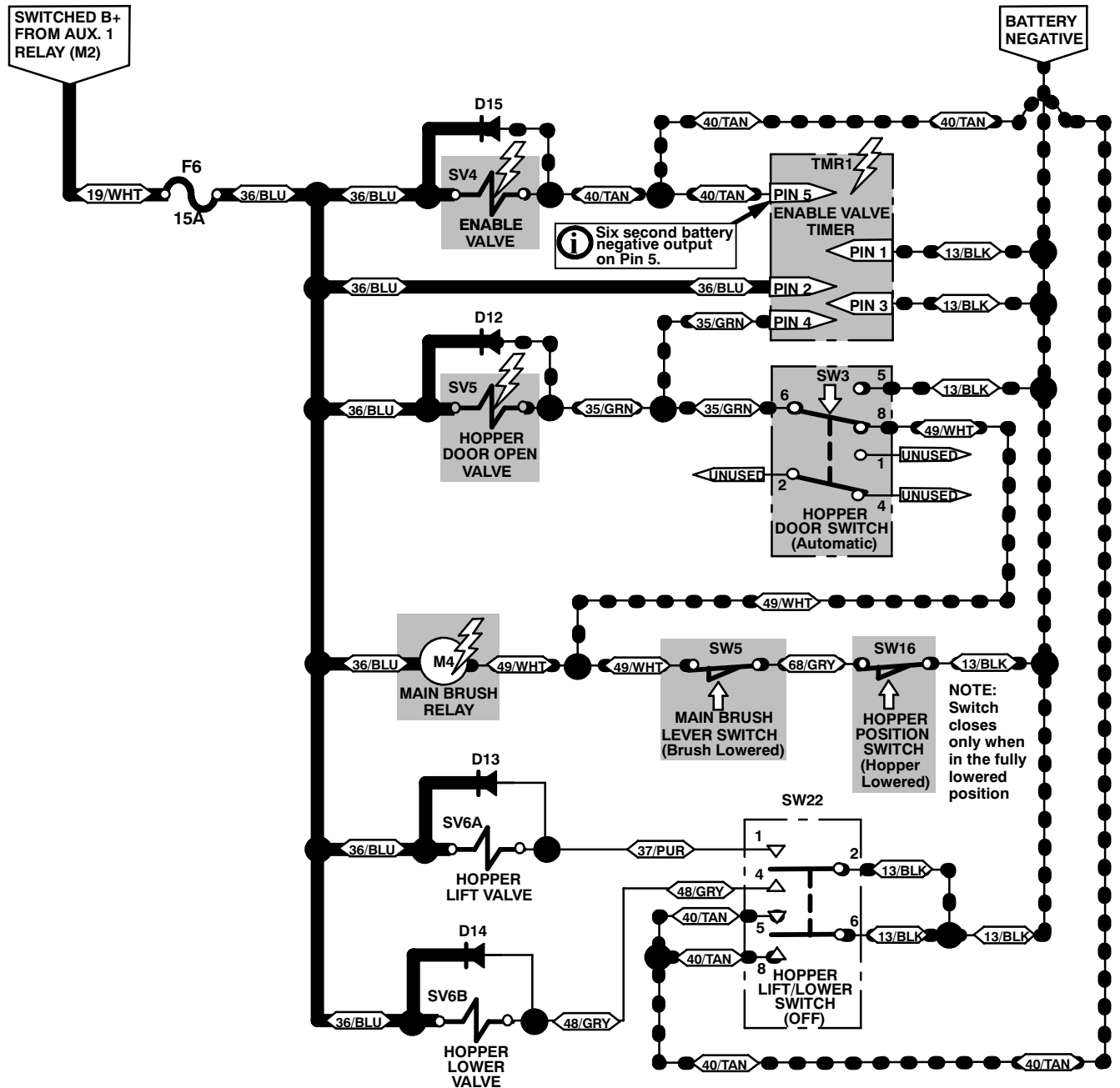

- i** - The Hopper Door Switch (SW3) is a 2-position switch. This drawing shows the switch in the Automatic Door position, which automatically opens the Hopper Door when sweeping, and closes it when the sweeping function is turned OFF.
- Enable Valve (SV4) must be energized when Lifting or Lowering the Hopper, or when Opening or Closing the Hopper Door. To open the Hopper Door, the Enable Valve (SV4) and the Hopper Door Open Valve (SV5) must be energized. To close the Hopper Door, ONLY the Enable Valve (SV4) must be energized (SV5 is OFF).
- The Enable Valve Timer (TMR1) energizes the Enable Valve (SV4) for 6 seconds when triggered. Triggering of TMR1 occurs when the Hopper Door Open Valve (SV5) is turned ON or OFF, and is input on Pin 4 of TMR1.

Hopper Door Open - Manual (S30)

Conditions: Key ON (RUN), Main Brush Lifted, Hopper Raised

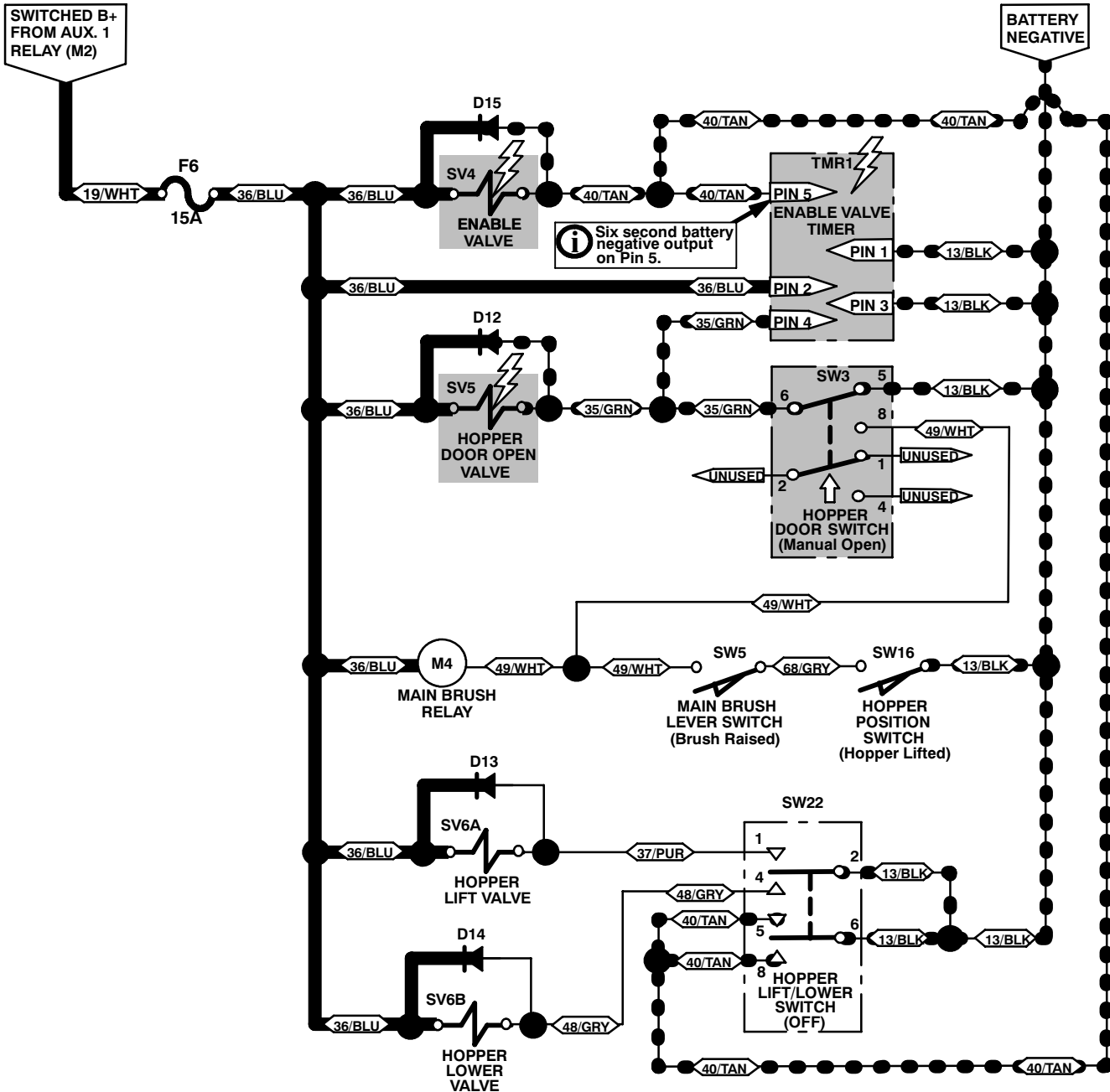

- i** - The Hopper Door Switch (SW3) is a 2-position switch. This drawing shows the switch in the Manual Open position, which opens the Hopper Door regardless of the Hopper position or sweeping function status (ON or OFF).
- Enable Valve (SV4) must be energized when Lifting or Lowering the Hopper, or when Opening or Closing the Hopper Door. To open the Hopper Door, the Enable Valve (SV4) and the Hopper Door Open Valve (SV5) must be energized. To close the Hopper Door, ONLY the Enable Valve (SV4) must be energized (SV5 is OFF).
- The Enable Valve Timer (TMR1) energizes the Enable Valve (SV4) for 6 seconds when triggered. Triggering of TMR1 occurs when the Hopper Door Open Valve (SV5) is turned ON or OFF, and is input on Pin 4 of TMR1.

Hopper Door Open (S30XP,S30X4)

Conditions: Key ON (RUN)

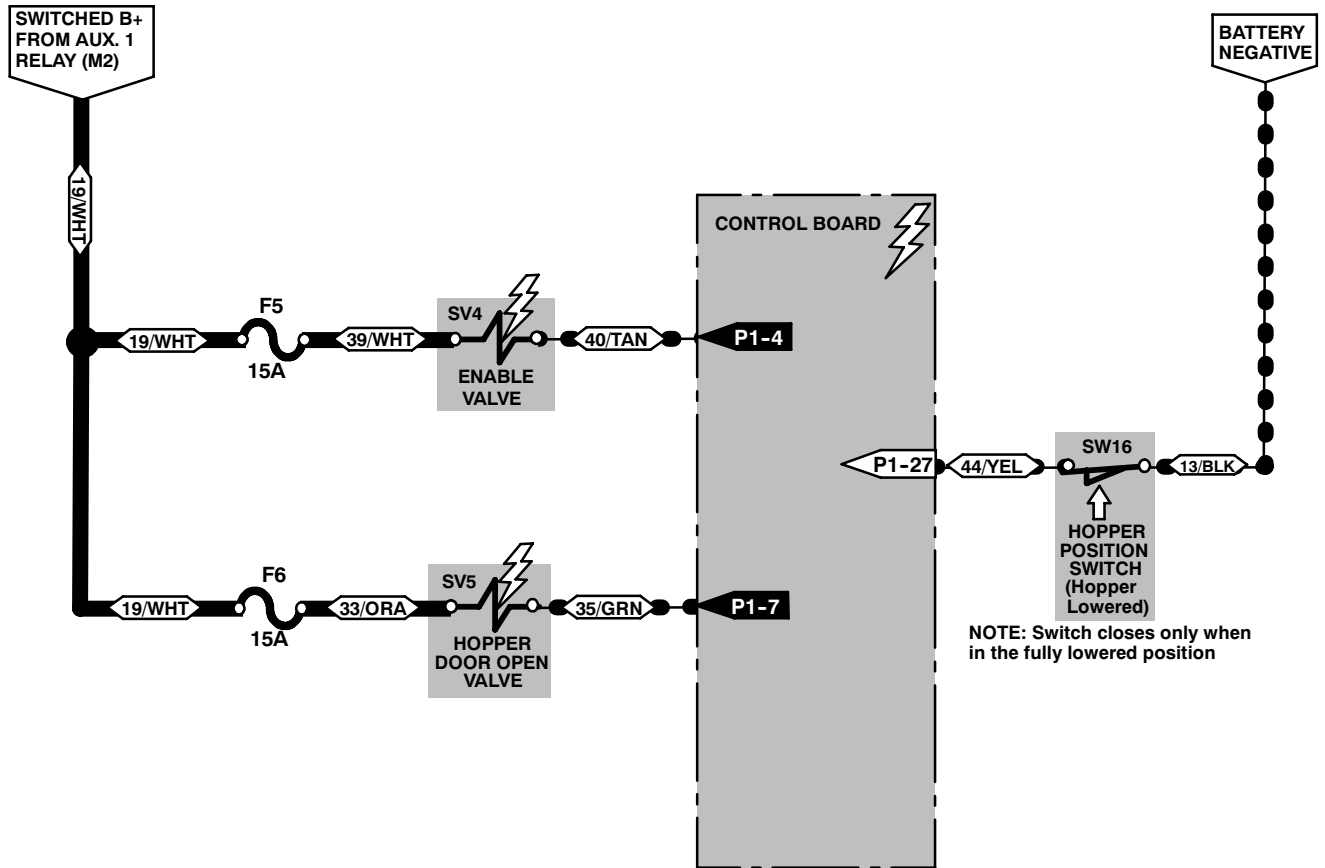

i - The Enable Valve (SV4) is ON ONLY during the following Hopper related functions:

- 1) Hopper Lift
- 2) Hopper Lower
- 3) Hopper Door Open
- 4) Hopper Door Close

- Lifting the Hopper or closing the Hopper Door turns OFF all sweeping related functions when the One-Step system is ON.

- Hopper Door automatically opens when activating the One-Step sweeping system.

Hopper Door Close - Automatic (S30)

Conditions: Key ON (RUN), Main Brush Raised, Hopper Down

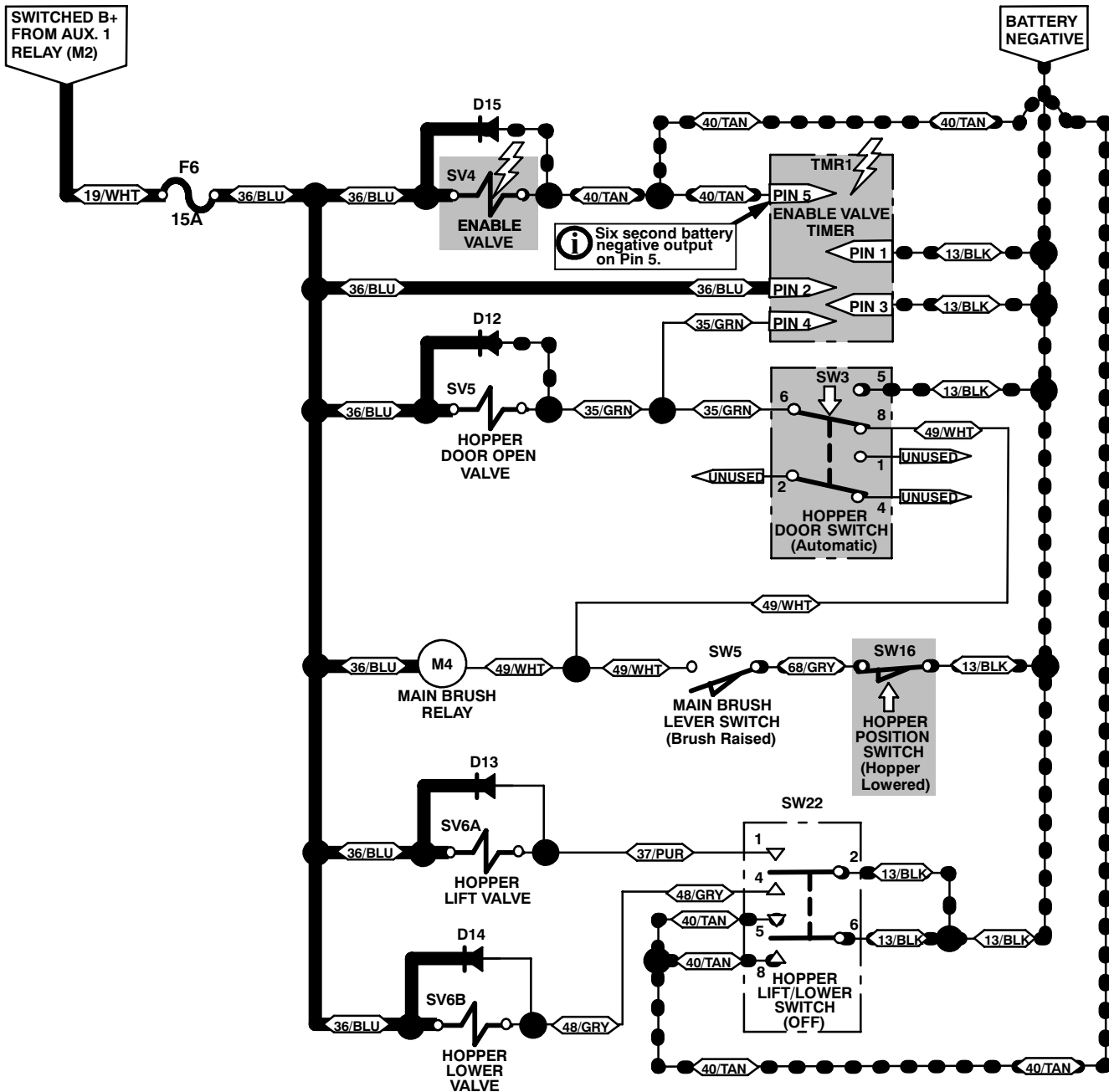

- i** - The Hopper Door Switch (SW3) is a 2-position switch. This drawing shows the switch in the Automatic Door position, which automatically opens the Hopper Door when sweeping, and closes it when the sweeping function is turned OFF.
- Enable Valve (SV4) must be energized when Lifting or Lowering the Hopper, or when Opening or Closing the Hopper Door. To open the Hopper Door, the Enable Valve (SV4) and the Hopper Door Open Valve (SV5) must be energized. To close the Hopper Door, ONLY the Enable Valve (SV4) must be energized (SV5 is OFF).
- The Enable Valve Timer (TMR1) energizes the Enable Valve (SV4) for 6 seconds when triggered. Triggering of TMR1 occurs when the Hopper Door Open Valve (SV5) is turned ON or OFF, and is input on Pin 4 of TMR1.

Hopper Door Close (S30XP,S30X4)

Conditions: Key ON (RUN)

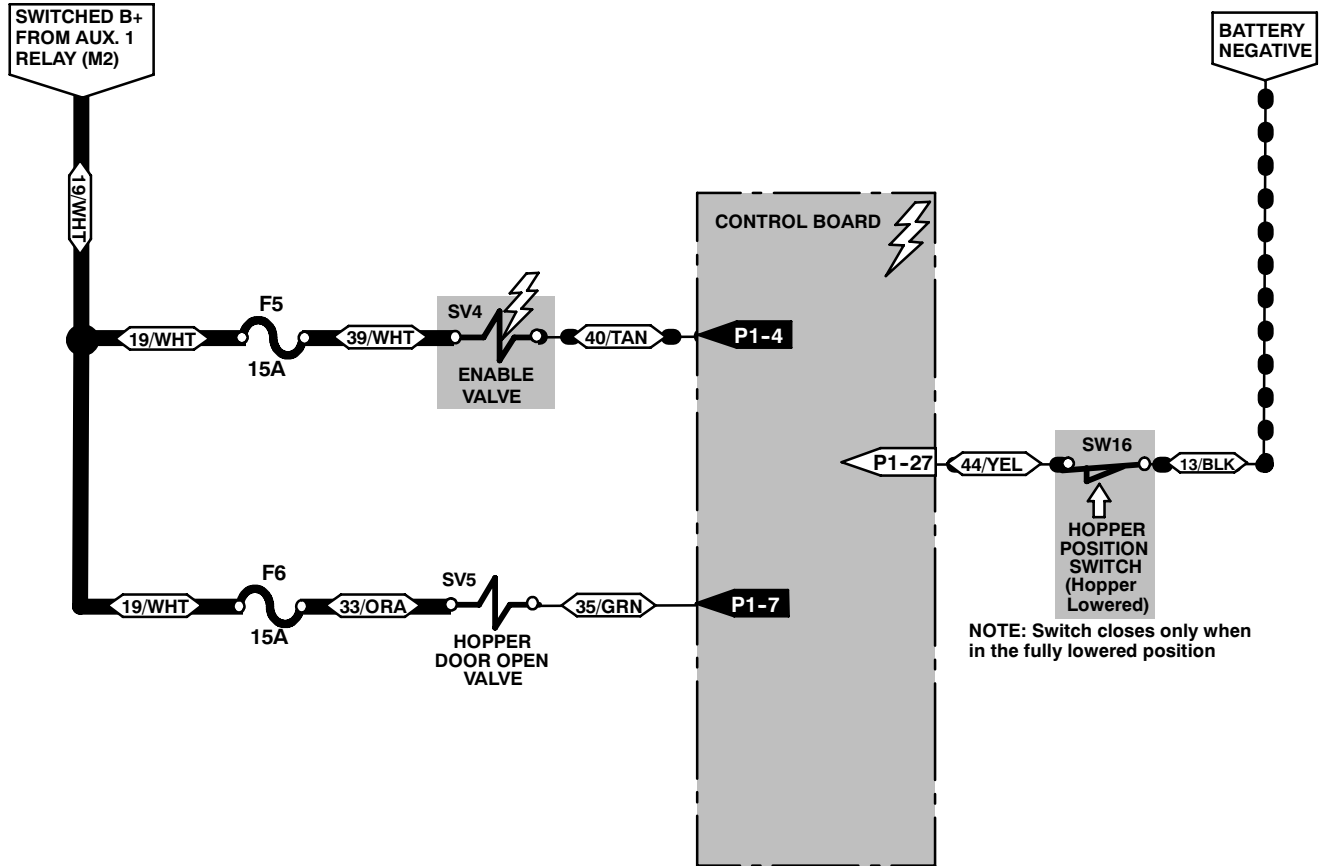

i - The Enable Valve (SV4) is ON ONLY during the following Hopper related functions:

- 1) Hopper Lift
- 2) Hopper Lower
- 3) Hopper Door Open
- 4) Hopper Door Close

- Lifting the Hopper or closing the Hopper Door turns OFF all sweeping related functions when the One-Step system is ON.

- Hopper Door automatically closes when deactivating the One-Step sweeping system.

Display Module Fault Indicators (S30)

The *fault indicator lights* illuminate when a fault has occurred. Stop the machine immediately and correct the problem if these indicators come on.

Refer to the table below to determine the cause and remedy for the fault.

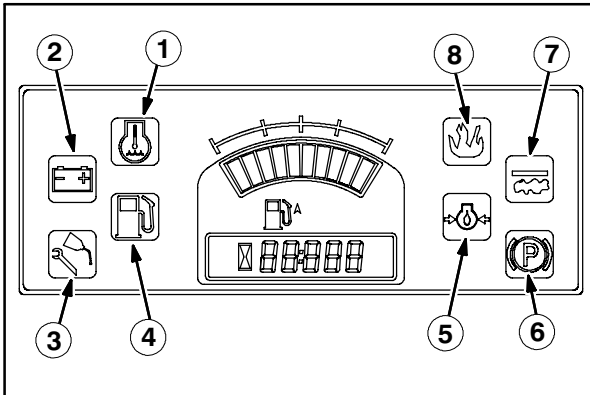

Fault Indicators	Cause(s)	Remedy
1: Water Temperature (Red)	Engine coolant is too hot to safely operate the machine	Shut off machine. Contact TENNANT service representative.
2: Charging System (Amber)	Alternator is not charging the battery.	Shut off machine. Contact TENNANT service representative.
3: Maintenance (Amber)	Not Used	Not Used
4: Fuel Level (Red)	Fuel level is low.	Refuel / Change fuel tank
5: Engine Oil Pressure (Red)	Oil pressure is below the normal operating pressure	Shut off machine. Contact TENNANT service representative.
6: Parking Brake (Amber)	Not Used	Not Used
7: Clogged Dust Filter (Amber)	Dust filter is clogged	Activate the filter shaker.
8: Hopper Fire (Red)	Fire in the hopper	Shut off machine. Extinguish fire. If necessary, call emergency personnel.

Fault Indicators (S30XP,S30X4)

This machine is equipped with two visual indicators, a red indicator light and an LCD (liquid crystal display).

The red indicator light will blink continuously indicating that a fault has occurred.



The LCD will display a fault code. If there is more than one fault, each fault will alternately display.



All faults are also accompanied by an audible alarm to alert the operator a fault has occurred.

Refer to the table below to determine the cause and remedy for the fault.

Fault Code (Displayed in LCD)	Cause(s)	Result	Remedy
F3: CLOGGED HYD FILTER	Hydraulic filter is clogged	-	Shut off machine. Contact TENNANT service representative.
F4: SHAKER FILTER	Hopper dust filter is clogged	-	Activate filter shaker to unclog hopper dust filter.
F5: HOPPER FIRE	Fire in the hopper	Terminates sweeping functions and closes hopper door	Shut off machine. Extinguish fire. If necessary, call emergency personnel.
F6: ALTERNATOR	Alternator not charging		Contact TENNANT service representative.
F7: LOW OIL PRESS	Engine oil pressure is low	Shuts down engine	Contact TENNANT service representative.
F8: HIGH ENG TEMP	Engine temperature is high	Shuts down engine	Shut off machine. Contact TENNANT service representative.
F9: HIGH HYD TEMP	Hydraulic fluid temperature is high	Cancels 1-Step sweep functions	Shut off machine. Contact TENNANT service representative.
F10: LOW FUEL	Low fuel	-	Fill fuel tank (gasoline). Replace fuel tank (LPG).
F18: HOPPER UP	Hopper is up	Terminates sweeping functions-	Lower hopper completely.
F20: UP KEY ERR	Hopper up button failure	Prevents all panel operations	Shut off machine. Contact TENNANT service representative.
F21: DN KEY ERR	Hopper down button failure	Prevents all panel operations	Shut off machine. Contact TENNANT service representative.
F22: OPN KEY ERR	Hopper door open button failure	Prevents all panel operations	Shut off machine. Contact TENNANT service representative.
F23: CL KEY ERR	Hopper door close button failure	Prevents all panel operations	Shut off machine. Contact TENNANT service representative.
F24: SEAT SWITCH (Option)	Operator not in the seat while engine is running and parking brake not engaged	Engine will shut off	Engage parking brake before leaving the machine.

Dash Fault Indicators (S30,S30XP,S30X4)

The *dash fault indicators* illuminate when a fault has occurred. Stop the machine immediately and correct the problem if these indicators come on.

Refer to the table below to determine the cause and remedy for the fault.

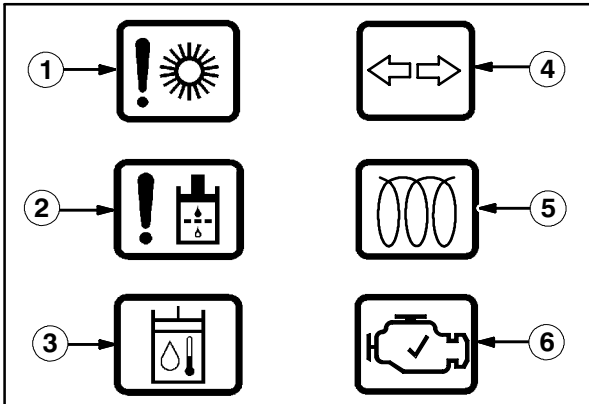

Warning Light	Cause(s)	Remedy
1: Stalled Brush	One of the brushes is stalled	Shut off machine and remove obstructions preventing brushes from operating
2: Hydraulic Filter	Hydraulic filter is clogged	Shut off machine. Contact TENNANT service representative
3: Hydraulic Temperature	Hydraulic system is too hot to safely operate the machine	Shut off machine. Contact TENNANT service representative
4: Hazard Flasher	Not Used	Not Used
5: Glow Plug - Preheat (Diesel machines only)	Not Used	Not Used
6: Check Engine	Engine control system detects a fault during machine operation	Shut off machine. Contact TENNANT service representative

Operating, Maintenance, & Diagnostic Modes (S30XP,S30X4)

(page 1 of 2)

In addition to normal operation, the S30XP/S30X4 has five modes that can be accessed. The five modes are:

- 1) Input Display Mode
- 2) Manual Mode
- 3) Reset Hourmeter
- 4) LED Brightness Adjustment Mode
- 5) Self Test / Display Error Mode

During normal operation, the control panel will show the following items after turning the key switch ON:

- 1) The first 8 segments on the LCD display turn ON and the control panel LED's illuminate briefly
- 2) The software revision date for 1 to 2 seconds
- 3) Fuel level and hourmeter
- 4) Condition and Fault messages when sensed

INPUT DISPLAY MODE

This mode allows the technician to observe if the inputs to the control board are operating as intended. Use this mode to test or troubleshoot the input switches, wiring, and circuit board logic. Refer to the chart after the following instructions for LED / Input associations.

To enter Input Display Mode:

- 1) Hold the "Side Brush" and the "4/5" panel buttons while turning ON the key switch. The key switch must be in the RUN position, but the engine does not have to be started.
- 2) Release buttons after 5 seconds. Confirm that the LCD display reads "CONFIG MODE".
- 3) Use the "2/3" button to scroll through the various modes until "INPUT MODE" is displayed.
- 4) Press the "0/1" button to select the mode. Confirm that the LCD display reads "INPUT MODE OPR".
- 5) Perform necessary tests.
- 6) Exit Input Display Mode by turning the key switch OFF.

Panel LED	LED ON Condition	LED OFF Condition	Pin #
Hopper UP LED	NO hopper fire	Hopper fire sensed	P1-13
Vacuum Fan LED	Low oil pressure	Oil pressure OK	P1-25
Hopper DOWN LED	Hopper fully lowered	Hopper raised	P1-27
Side Brush LED	High engine temperature	Engine temperature OK	P1-23
Filter Shaker LED	Sweep filter OK	Sweep filter clogged	P1-14
Hopper Door Closed LED	Not used	Not used	x
Hopper Door Open LED	Alternator NOT charging	Alternator charging OK	P1-16
One-Step Sweep LED	Not used	Not used	x

MANUAL MODE

This mode allows the technician to turn ON various machine functions regardless of the status of the sensed inputs or interlocks. For example, the main brush can be turned ON with the hopper raised.

To enter Manual Mode:

- 1) Hold the "Side Brush" and the "4/5" panel buttons while turning ON the key switch. The key switch must be in the RUN position, but the engine does not have to be started.
- 2) Release buttons after 5 seconds. Confirm that the LCD display reads "CONFIG MODE".
- 3) Use the "2/3" button to scroll through the various modes until "MANUAL MODE" is displayed.
- 4) Press the "0/1" button to select the mode. Confirm that the LCD display reads "MANUAL MODE OPR".
- 5) Perform any necessary tests or repairs.
- 6) Exit Manual Mode by turning the key switch OFF.

Operating, Maintenance, & Diagnostic Modes (S30XP,S30X4)

(page 2 of 2)

RESET HOURMETER MODE

Contact the Tennant Warranty Department if the hourmeter needs to be reset. The Warranty Department will determine if it is appropriate to reset the hourmeter, and will provide the steps needed to perform this function. The Tennant Warranty Department can be contacted by calling 1-800-553-8033.

LED BRIGHTNESS ADJUSTMENT MODE

This mode allows the technician to adjust the brightness of the LED's on the control panel.

To enter LED Brightness Adjustment Mode:

- 1) Hold the "Side Brush" and the "4/5" panel buttons while turning ON the key switch. The key switch must be in the RUN position, but the engine does not have to be started.
- 2) Release buttons after 5 seconds. Confirm that the LCD display reads "CONFIG MODE".
- 3) Use the "2/3" button to scroll through the various modes until "LED BRIGHTNESS" is displayed.
- 4) Press the "0/1" button to select the mode.
- 5) Press & hold the "8/9" button to slowly increase the control panel LED brightness. Release the button to set the brightness level. To reduce the brightness, press & hold the "8/9" button again until the desired brightness level is attained, then release button.
- 6) Exit LED Brightness Adjustment Mode by turning the key switch OFF.

SELF TEST / DISPLAY ERROR MODE

E This mode allows the technician to determine the status of the electrical load on each output from the control board. The self test takes less than one second to perform. If the control board passes the test, "OK" will be displayed. If the panel fails the test, the pin number of the failing output(s) will be displayed. If "OPEN LOAD" is displayed after the pin number, the self test found the output from that pin electrically open. If "SHORT LOAD" is displayed after the pin number, the self test found the output from that pin electrically shorted to battery positive (B+). Repair the output wires or replace the component as needed.

NOTE: P1-15 will always result in an "OPEN LOAD" error unless the Clogged Hydraulic Filter Switch (S4) is shorted across the terminals to test the output, as this is a normally open switch. Also, P1-24 will also result in an "OPEN LOAD" since this output is not currently being used.

To enter Self Test / Display Error Mode:

- 1) Hold the "Side Brush" and the "4/5" panel buttons while turning ON the key switch. The key switch must be in the RUN position, but the engine does not have to be started.
- 2) Release buttons after 5 seconds. Confirm that the LCD display reads "CONFIG MODE".
- 3) Use the "2/3" button to scroll through the various modes until "SELF TEST" is displayed.
- 4) Press the "0/1" button to select the mode.
- 5) Using the displayed information, perform any necessary tests or repairs.
- 6) Exit Self Test / Display Error Mode by turning the key switch OFF.

Circuit Board Pin Functions (S30XP,S30X4)

Pin #	Function	Active Voltage	Inactive Voltage
P1-1	Chassis ground (static)	B-	B-
P1-2	Power, battery positive	B+	B-
P1-3	Power, battery positive	B+	B-
P1-4	Output, SV4	B-	B+
P1-5	Output, SV1 & SV8	B-	B+
P1-6	Input, analog, S7	See NOTE 1	See NOTE 1
P1-7	Output, SV5	B-	B+
P1-8	Output, SV6A	B-	B+
P1-9	Output, SV6B	B-	B+
P1-10	Output, SV2	B-	B+
P1-11	Output, M3	B-	B+
P1-12	Not Used	x	x
P1-13	Input, digital, S14	B-	5 VDC
P1-14	Input, digital, S8	B-	5 VDC
P1-15	Output, LP11	B-	B+
P1-16	Input, digital, Alternator	B-	5 VDC
P1-17	Not Used	x	x
P1-18	Not Used	x	x
P1-19	Output, LP12	B-	B+
P1-20	Output, Governor	OPEN	B+
P1-21	Output, Governor	OPEN	B+
P1-22	Ground, battery negative	B-	B-
P1-23	Input, analog, S10	See NOTE 2	See NOTE 2
P1-24	Not Used	x	x
P1-25	Input, digital, S11	B-	5 VDC
P1-26	Input, digital, seat switch	B-	5 VDC
P1-27	Input, digital, SW16	B-	5 VDC
P1-28	Input, analog, S2 or S3	See NOTE 3	See NOTE 3
P1-29	Input, digital, S1	B-	5 VDC
P1-30	Not Used	x	x
P1-31	Output, SV3 & SV7	B-	B+
P1-32	Memory storage	B+	B+
P1-33	Ground, battery negative	B-	B-
P1-34	Ground, battery negative	B-	B-
P1-35	Ground, battery negative	B-	B-

NOTE 1 - Hydraulic Oil Temperature Sender (S7) specifications: High temperature indicated when oil is 107°C (225°F) or higher. Temperature sender measures approximately 75 Ohms at 107°C (225°F). Resistance lessens as temperature increases.

NOTE 2 - Engine Temperature Sender (S10) specifications: High temperature indicated when coolant is 107°C (225°F) or higher. Temperature sender measures approximately 75 Ohms at 107°C (225°F). Resistance lessens as temperature increases.

NOTE 3 - GASOLINE/DIESEL engines - Fuel Sender (S2) specifications: Fuel sender measures approximately 90 Ohms with a full fuel tank, and approximately 5 Ohms with an empty fuel tank.

LPG engines - Fuel Switch (S3) specifications: Fuel switch is open above approximately 4.8 BAR (70 PSI), indicating sufficient fuel, and measures approximately 0 Ohms below this pressure, indicating low fuel.

HYDRAULIC

Troubleshooting Information

BEFORE CONDUCTING TESTS:

- * Read and Follow ALL Safety Warnings and Precautions as mentioned at the beginning of this manual
- * Engine & Hydraulic Oil Must Be At Normal Operating Temperatures after Running Machine and Hydraulics a Minimum of 5 Minutes
- * Examine Machine For Any Linkage Binding or Mechanical Problems

DURING TESTS:

- * Call Technical Services if Diagnostic Time Exceeds One Hour With Unknown Cause or Course of Action
- * Maintain Normal Main Brush Pressure as Listed in Operator's Manual

NOTE: Troubleshooting charts may be shown with optional equipment. The optional equipment may not be specified in these charts. Some machines may not be equipped with all components shown.

General Information (S30, S30XP, S30X4)

Page 1 of 2

Commonly Used Hydraulic Symbols

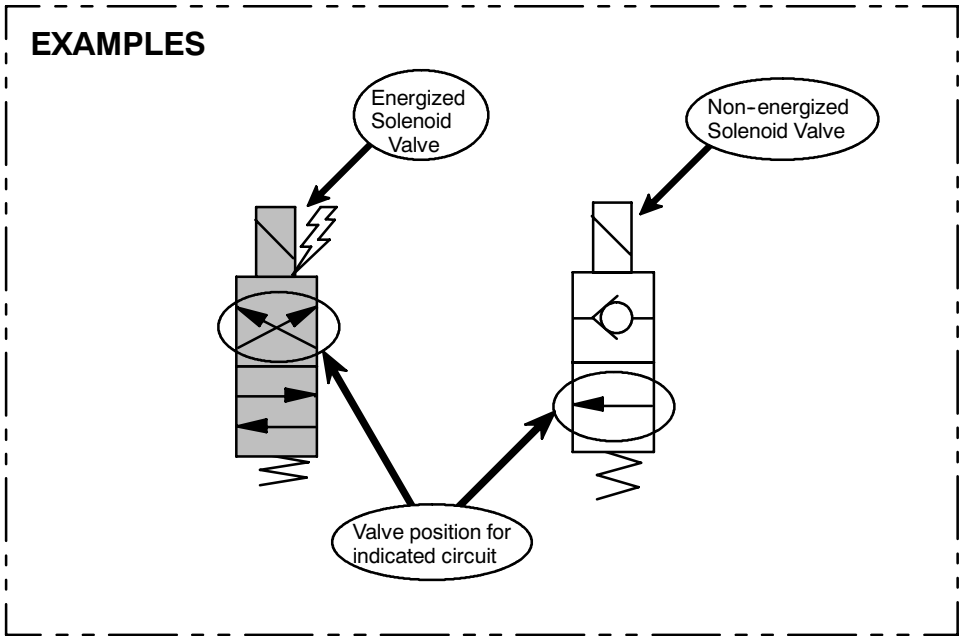
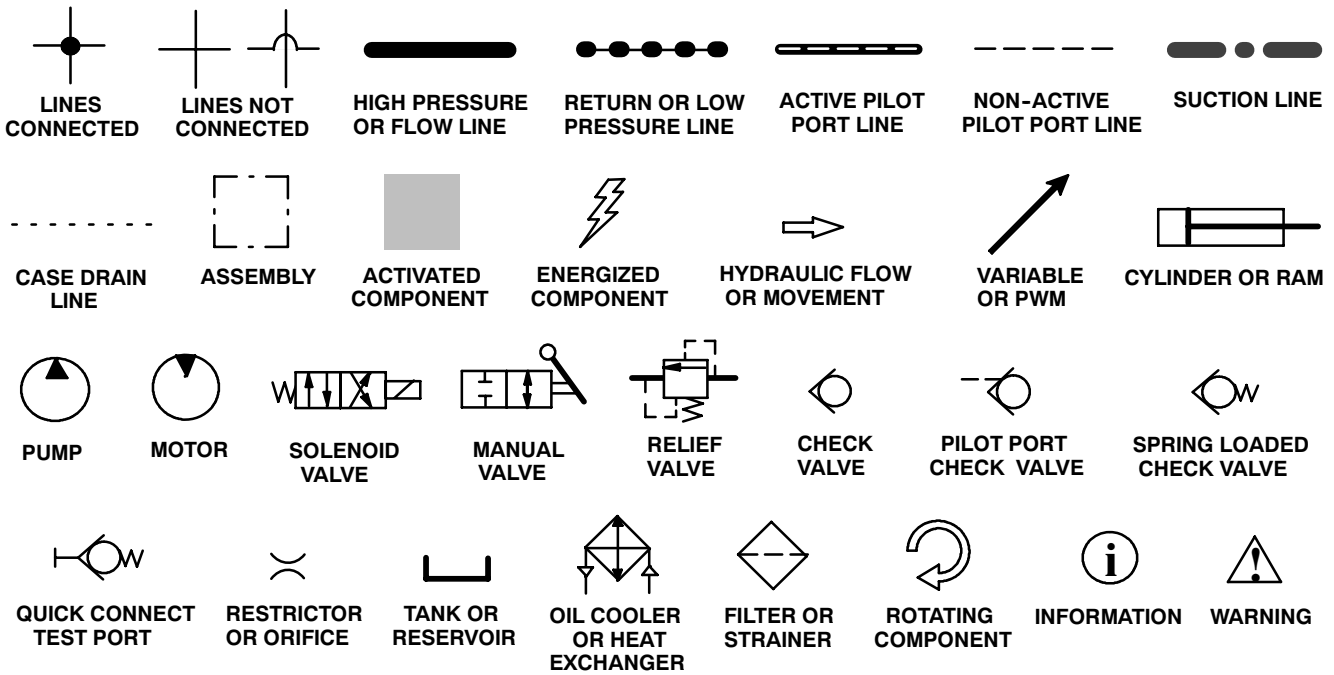

H

General Information (S30, S30XP, S30X4)

Page 2 of 2

Hydraulic Pump Flow Rates (typical)

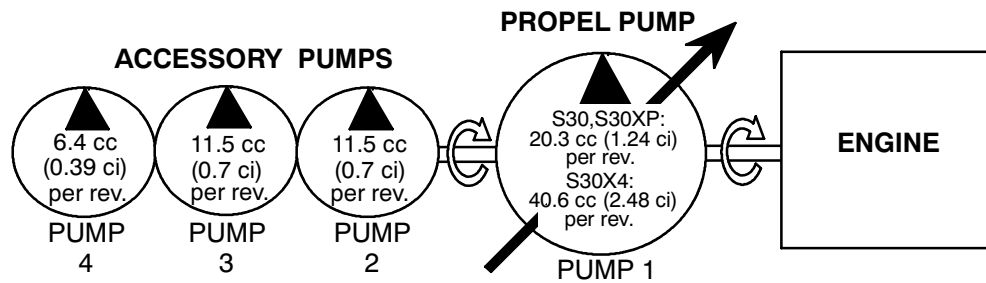

Pump	Displacement	Volume @ 2000RPM	Volume @ 2400RPM
Pump 1 (S30, S30XP)	20.3 cc (1.24 ci)	40.5 lpm (10.7 gpm)	48.4 lpm (12.8 gpm)
Pump 1 (S30X4)	40.6 cc (2.46 ci)	81.0 lpm (21.4 gpm)	96.5 lpm (25.5 gpm)
Pump 2	11.5 cc (0.7 ci)	22.7 lpm (6.0 gpm)	27.2 lpm (7.2 gpm)
Pump 3	11.5 cc (0.7 ci)	22.7 lpm (6.0 gpm)	27.2 lpm (7.2 gpm)
Pump 4	6.4 cc (0.39 ci)	12.5 lpm (3.3 gpm)	15.1 lpm (4.0 gpm)

Commonly Used Abbreviations			
AUX	Auxiliary	MFLD	Manifold
CC	Cubic Centimeters	MTR	Motor
CK	Check Valve	OR	Orifice
CM	Centimeters	PC	Pilot Port Check Valve
CU	Cubic	PMP	Pump
CV	Control Valve	PSI	Pounds Per Square Inch
CYL	Cylinder	PSWITCH	Pressure Switch
DC	Direct Current	PWM	Pulse Width Modulation
DCn	Disconnect (Test Port)	RES	Reservoir
FLTR	Filter	RH	Right Hand
GPM	Gallons Per Minute	RPM	Revolutions Per Minute
HTX	Heat Exchanger	RV	Relief Valve
IN	Inches	SC	Spring Loaded Check Valve
kPa	KiloPascals	STRN	Strainer
LH	Left Hand	SV	Solenoid Valve
LPM	Liters Per Minute	SW	Switch
M	Motor (Combustion)	V	Volts

Hydraulic Manifold Port Markings			
C	Cylinder Connection	P	Pump Connection
G	Test Port	PS	Pressure Switch Connection
M	Motor Connection	T	Tank Connection

Hydraulic Schematic (S30, S30XP)

(page 1 of 2)

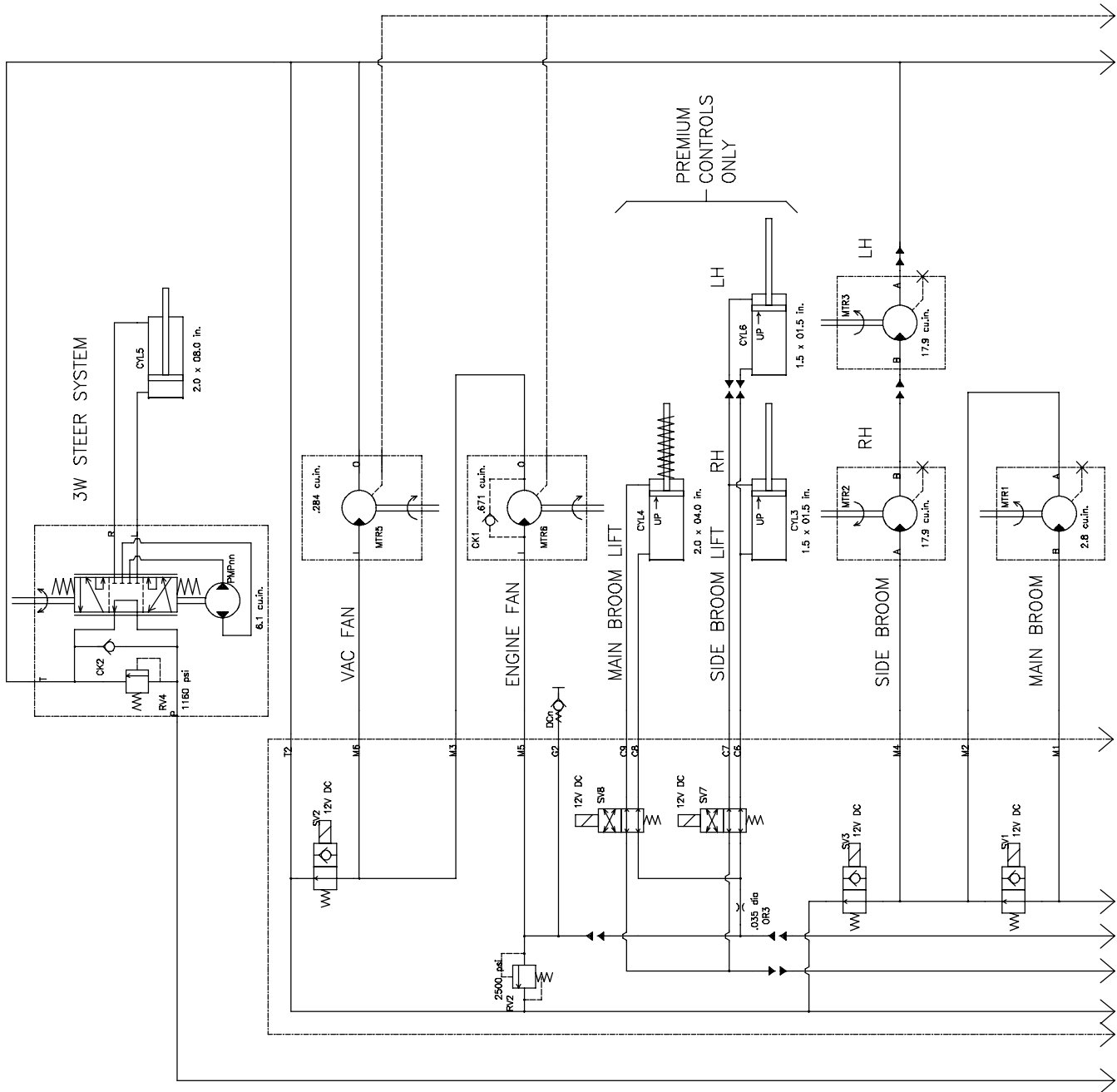

Hydraulic Schematic (S30, S30XP)

(page 2 of 2)

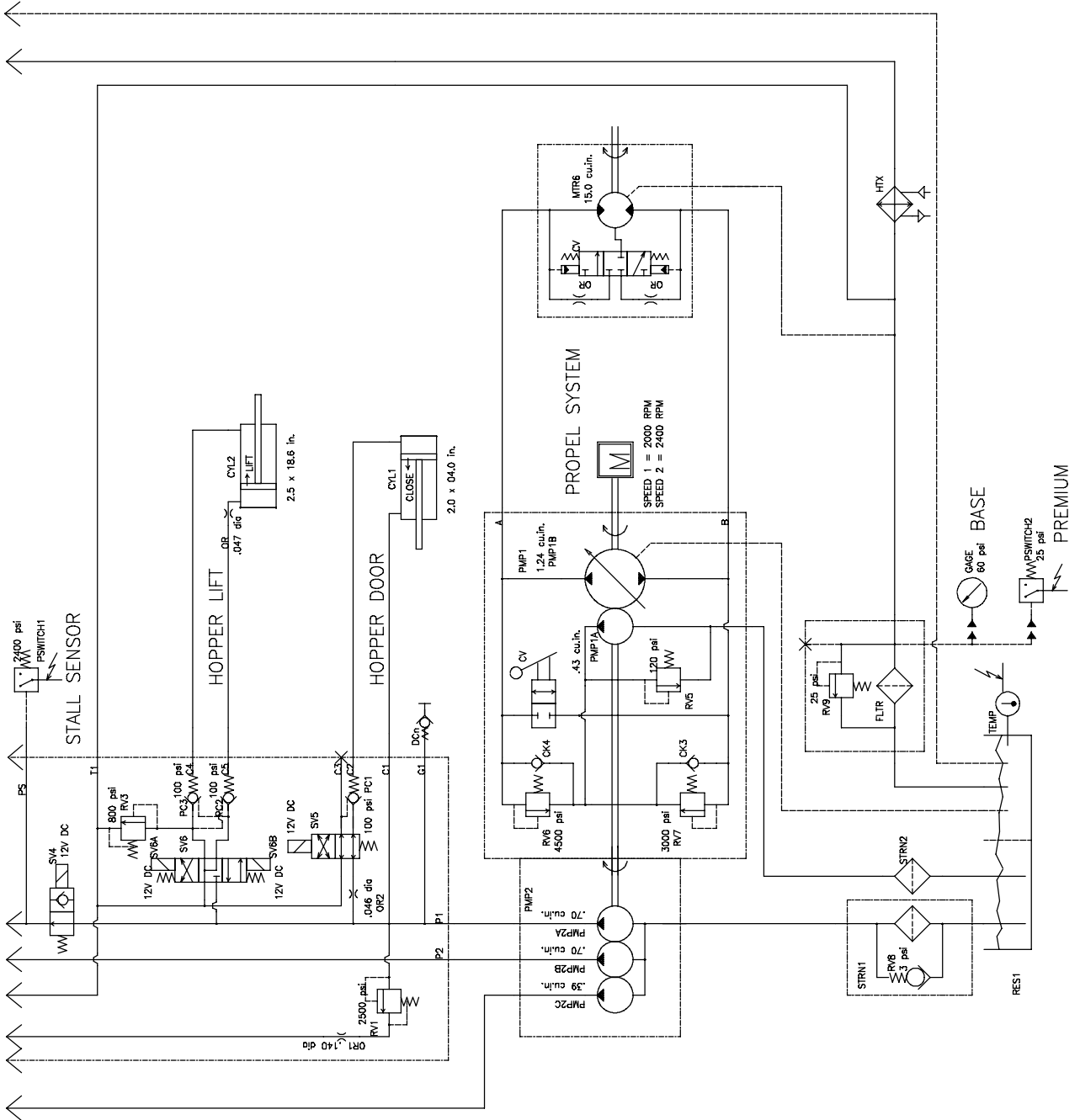

Hydraulic Schematic (S30X4)

(page 1 of 2)

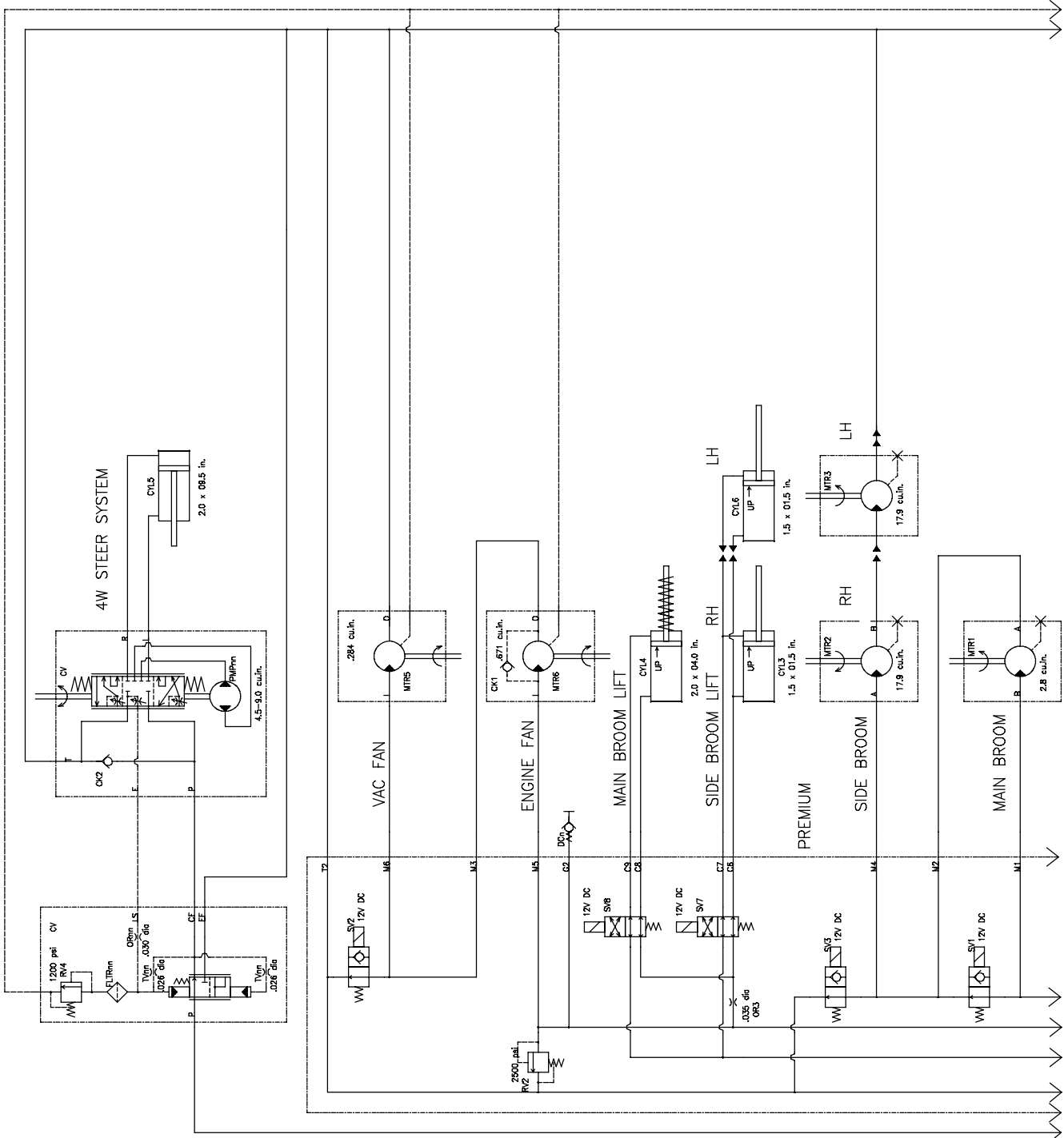

Hydraulic Schematic (S30X4)

(page 2 of 2)

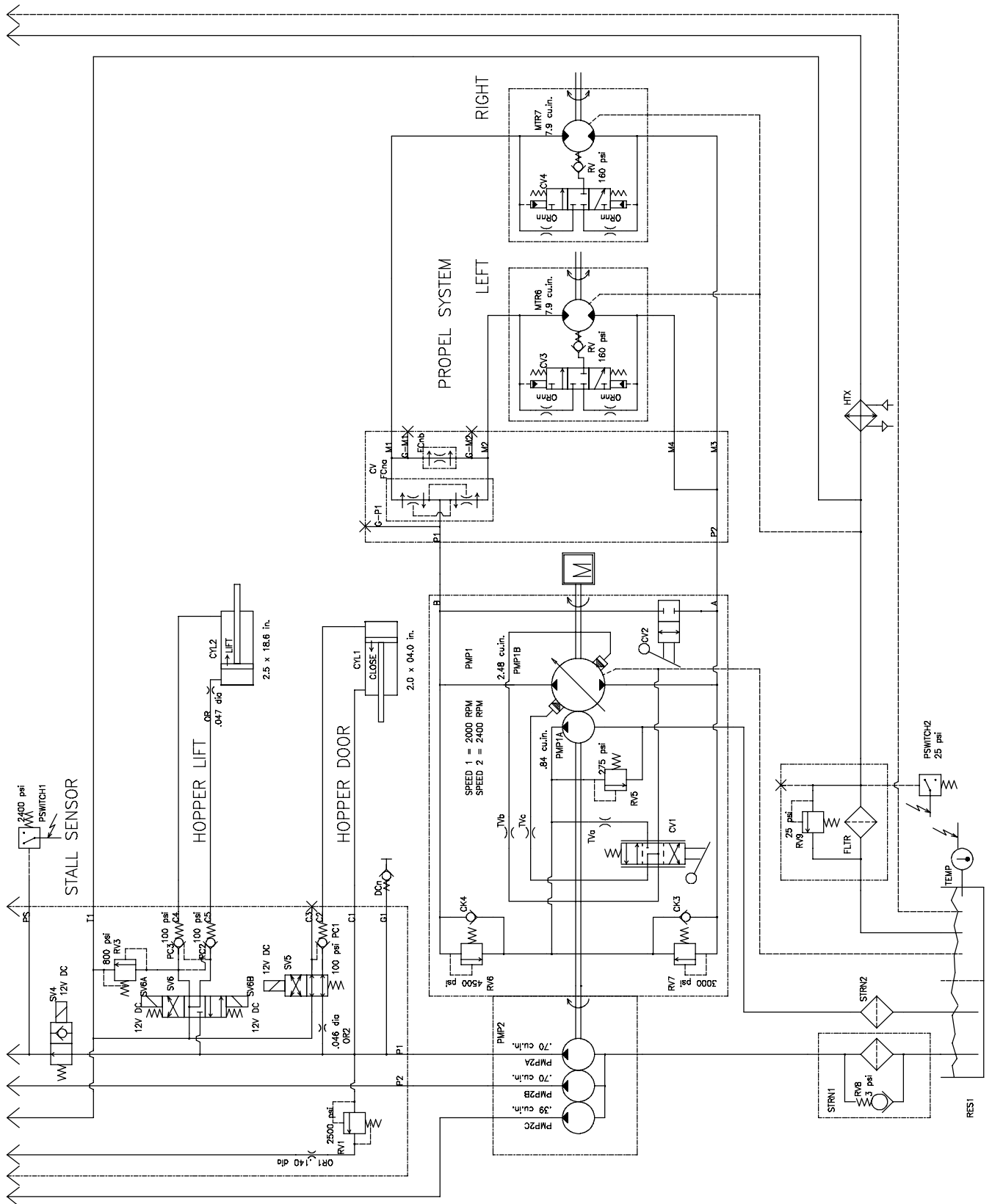

Overall Hydraulic Hose Diagram (S30)

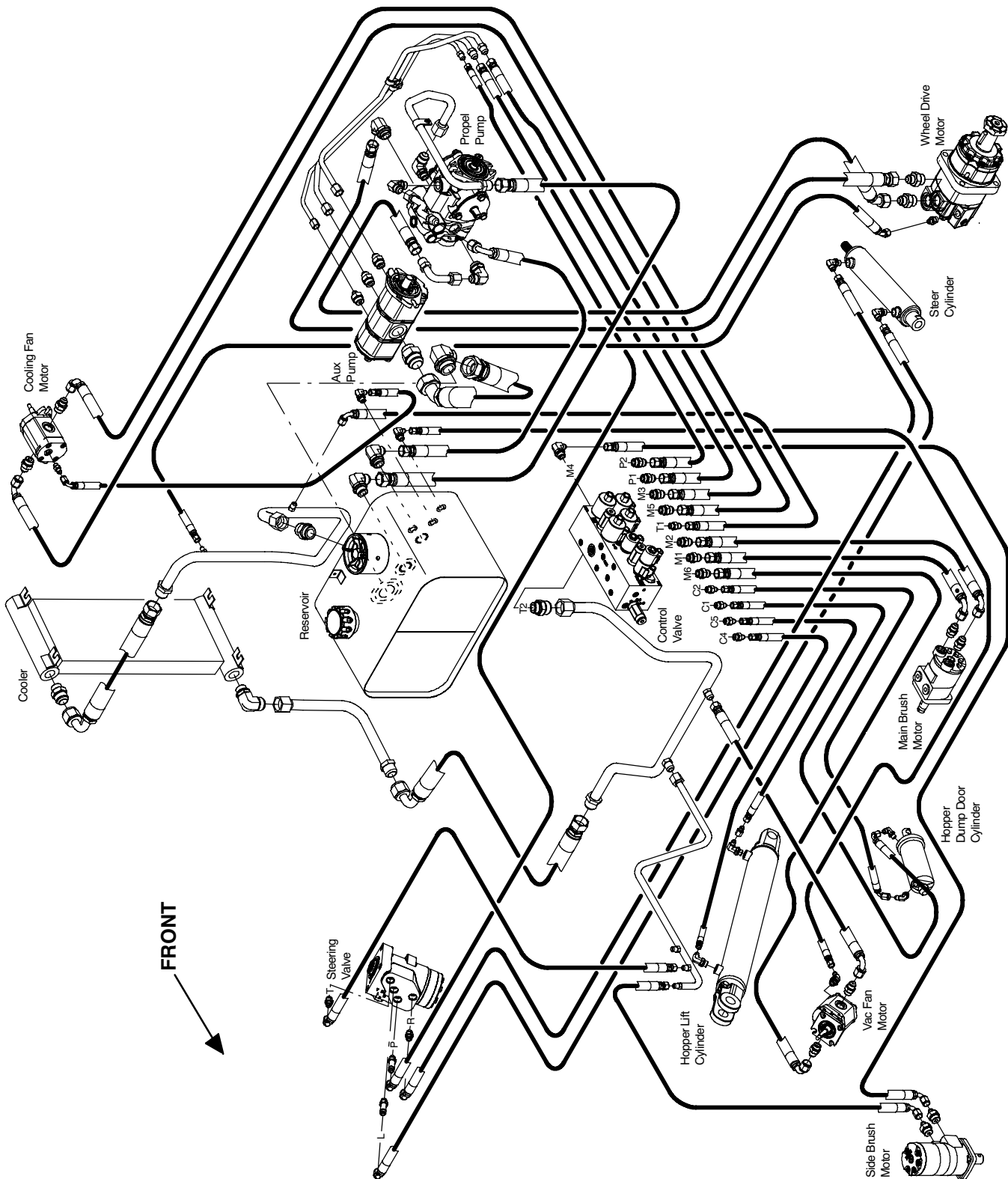

Overall Hydraulic Hose Diagram (S30XP)

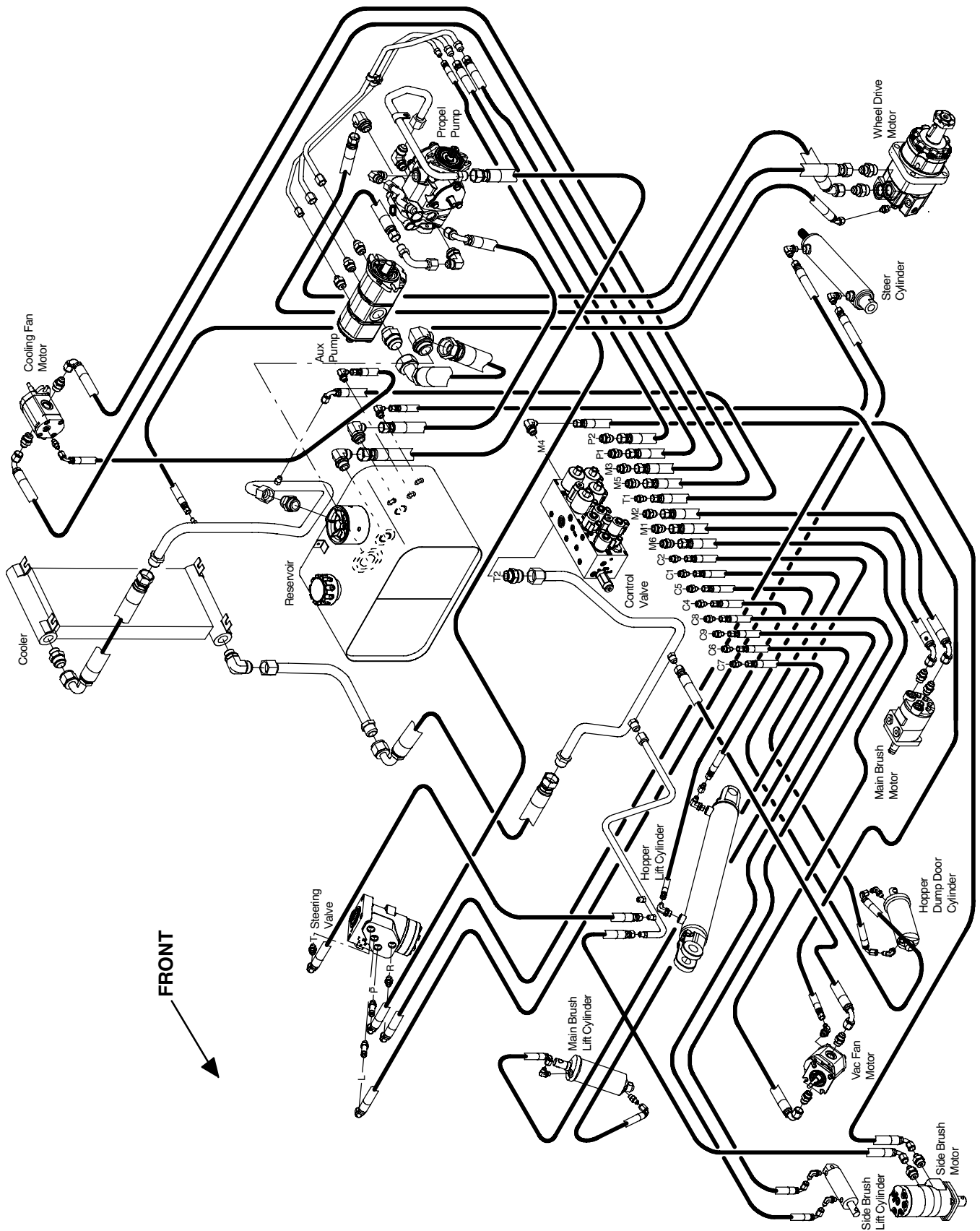

Overall Hydraulic Hose Diagram (S30X4)

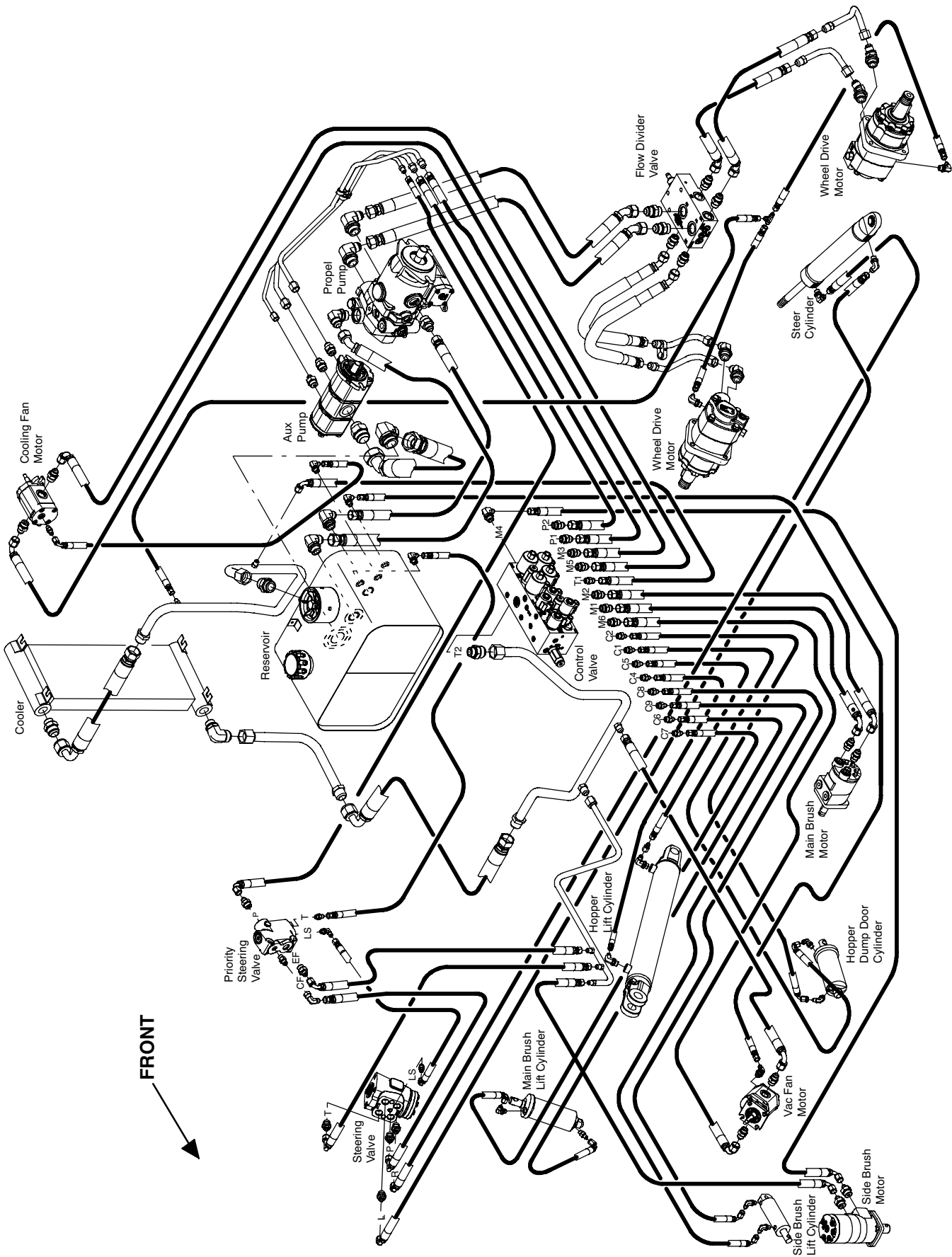

Hydraulic Reservoir Hose Diagram

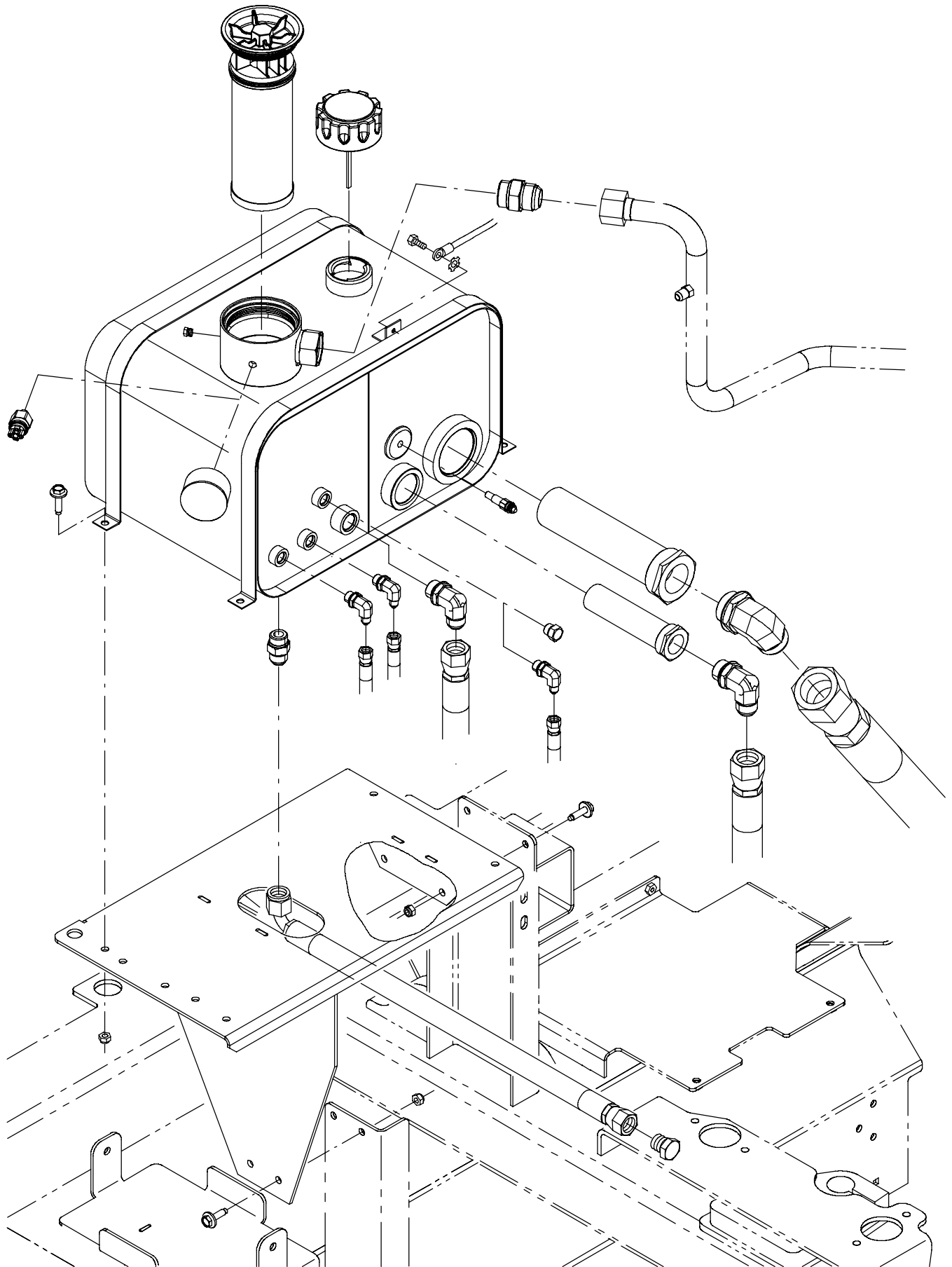

Hydraulic Cooler Hose & Tube Diagram

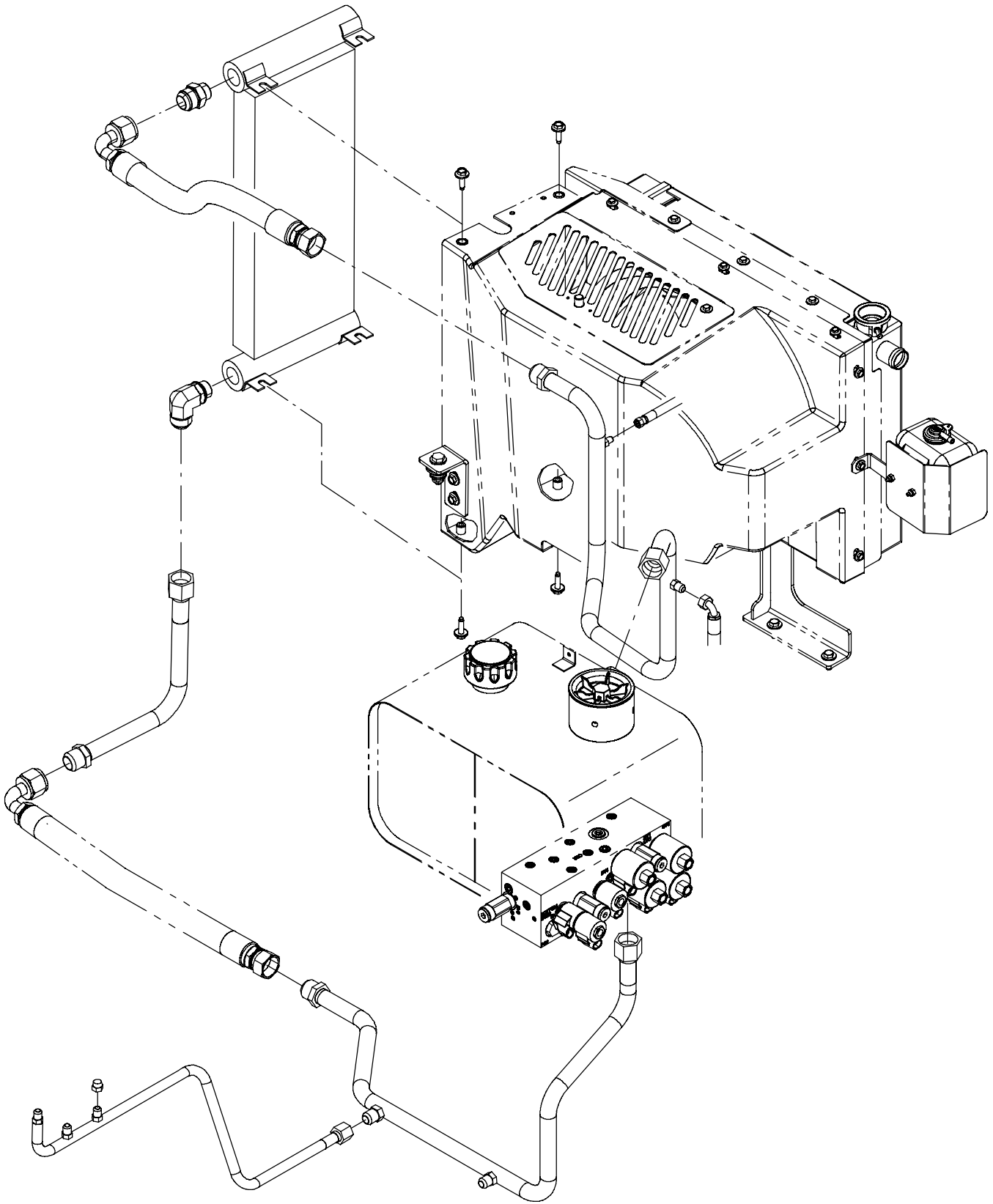

H

Hydraulic Pumps Diagram (S30, S30XP)

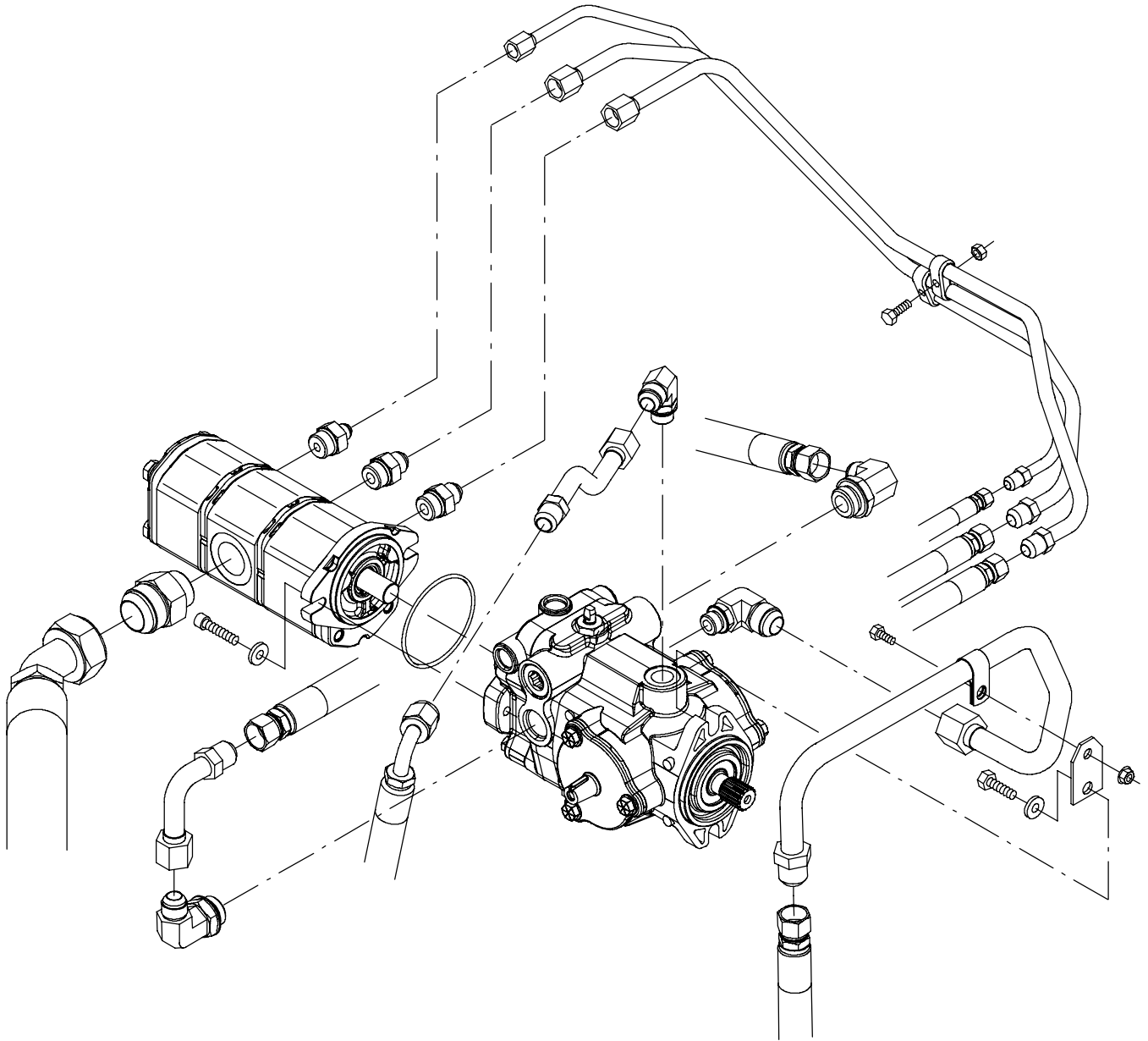

Hydraulic Pumps Diagram (S30X4)

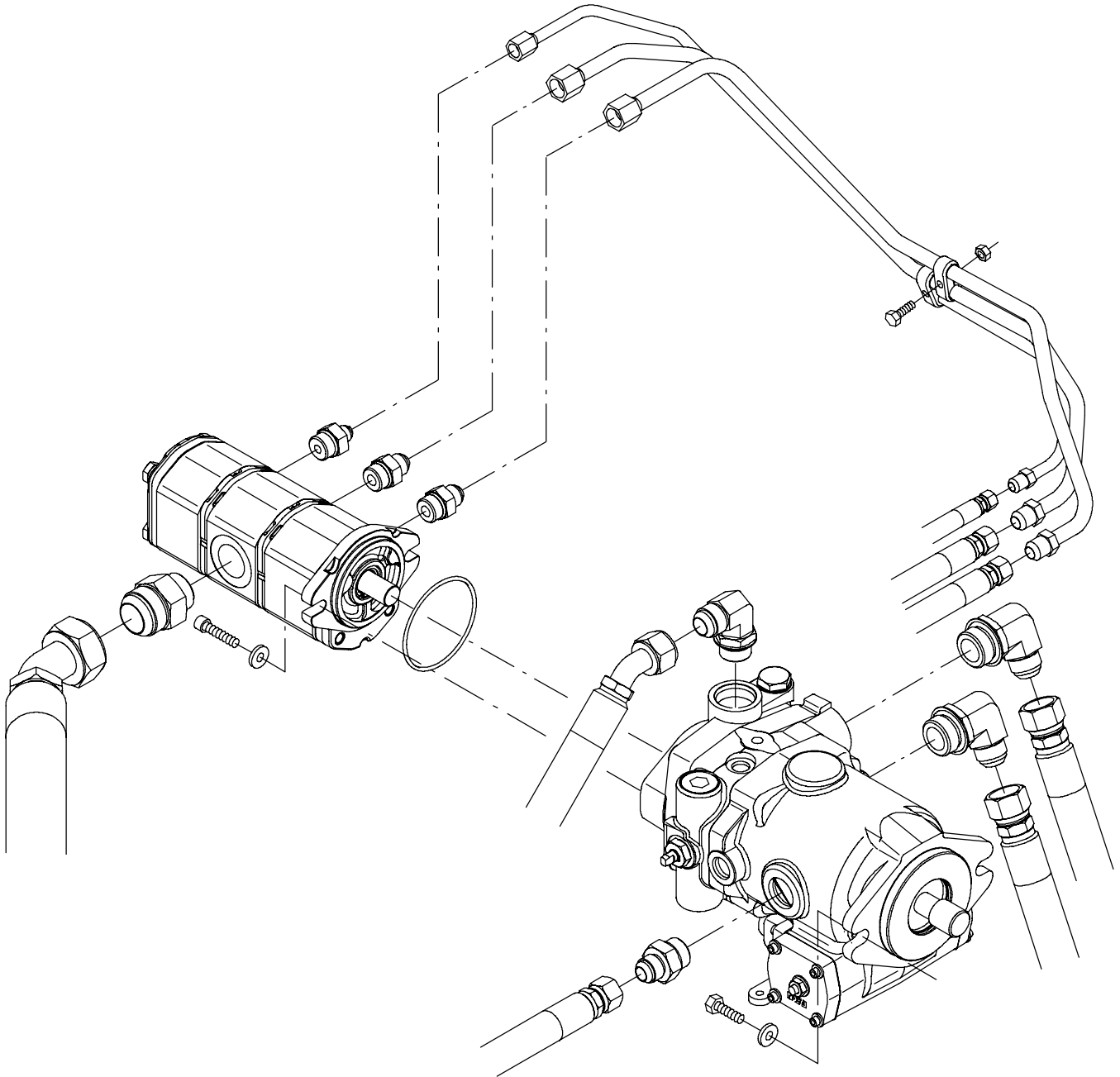

H

Hydraulic Valve Block Diagram (S30)

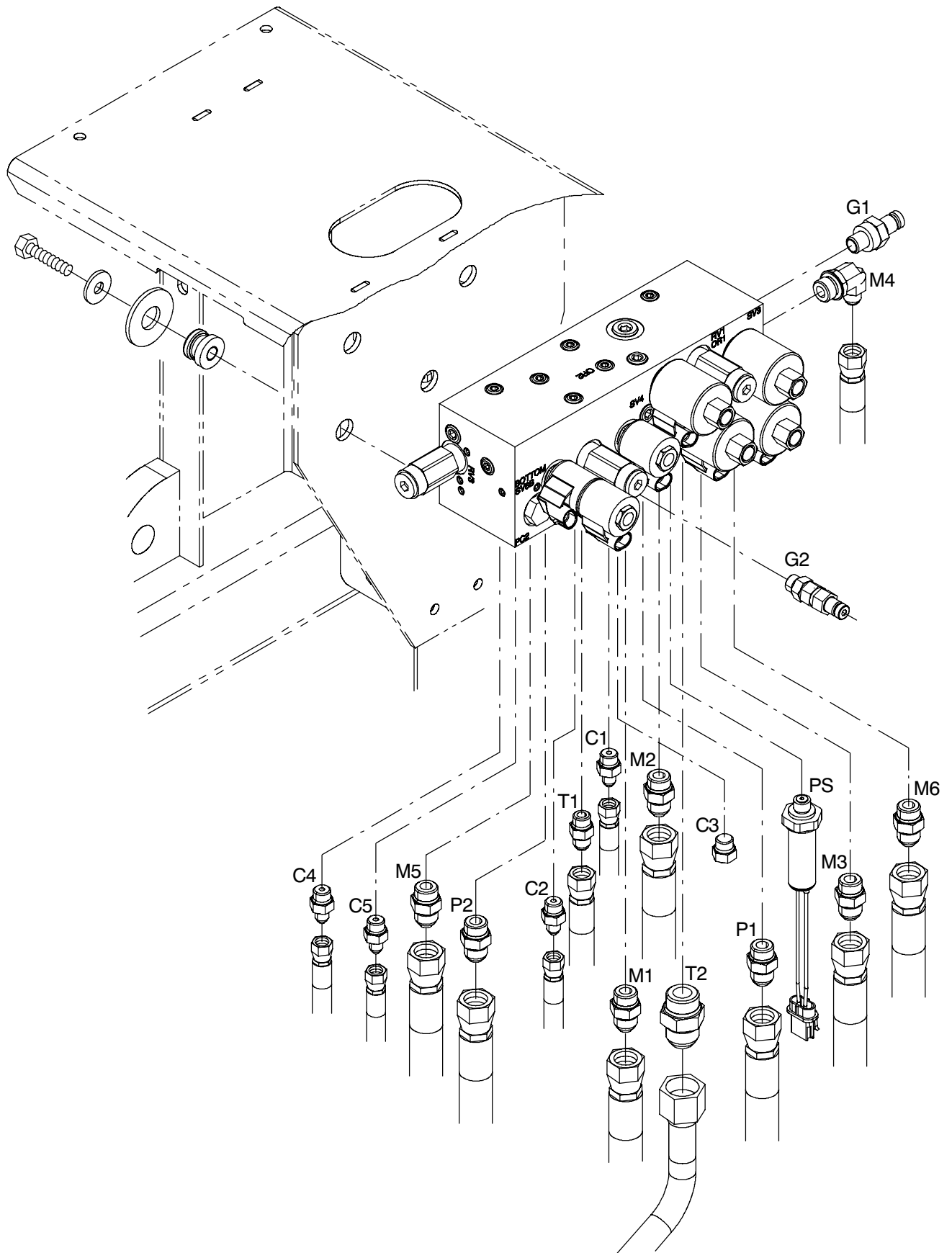

Hydraulic Valve Block Diagram (S30XP, S30X4)

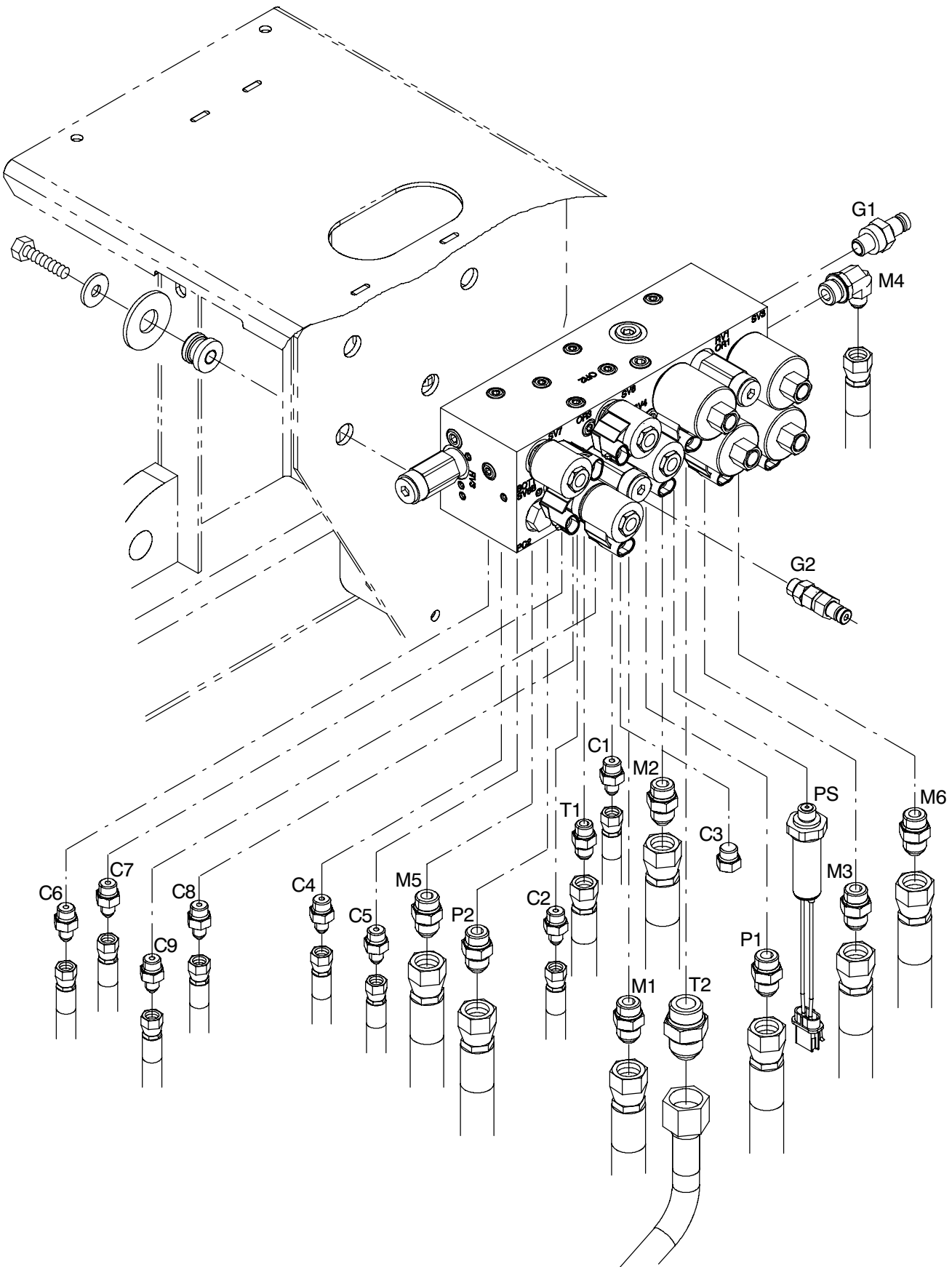

Hydraulic Priority and Flow Divider Valve Diagram (S30X4)

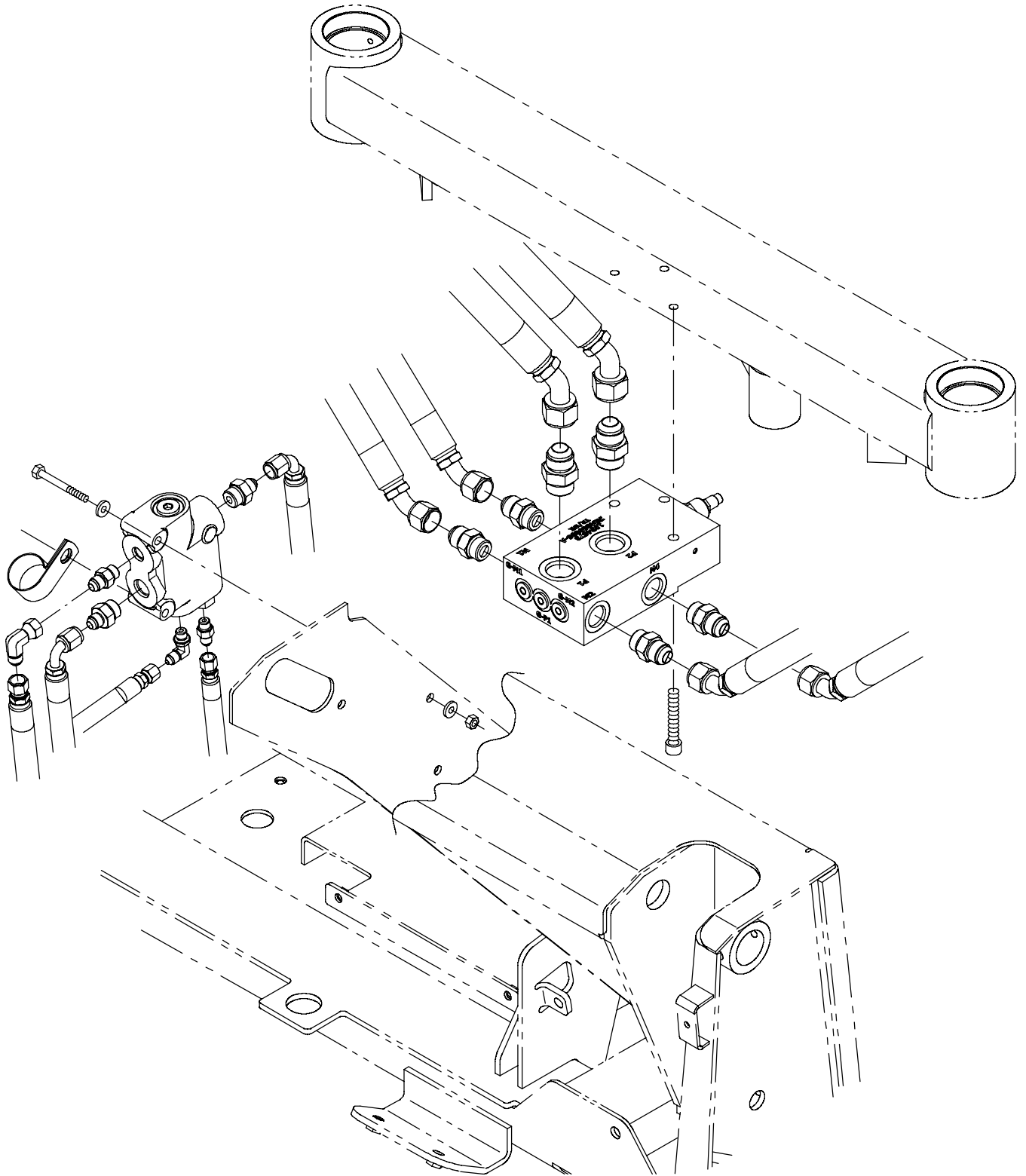

Left Hand Side Brush Hydraulic Diagram (S30XP, S30X4)

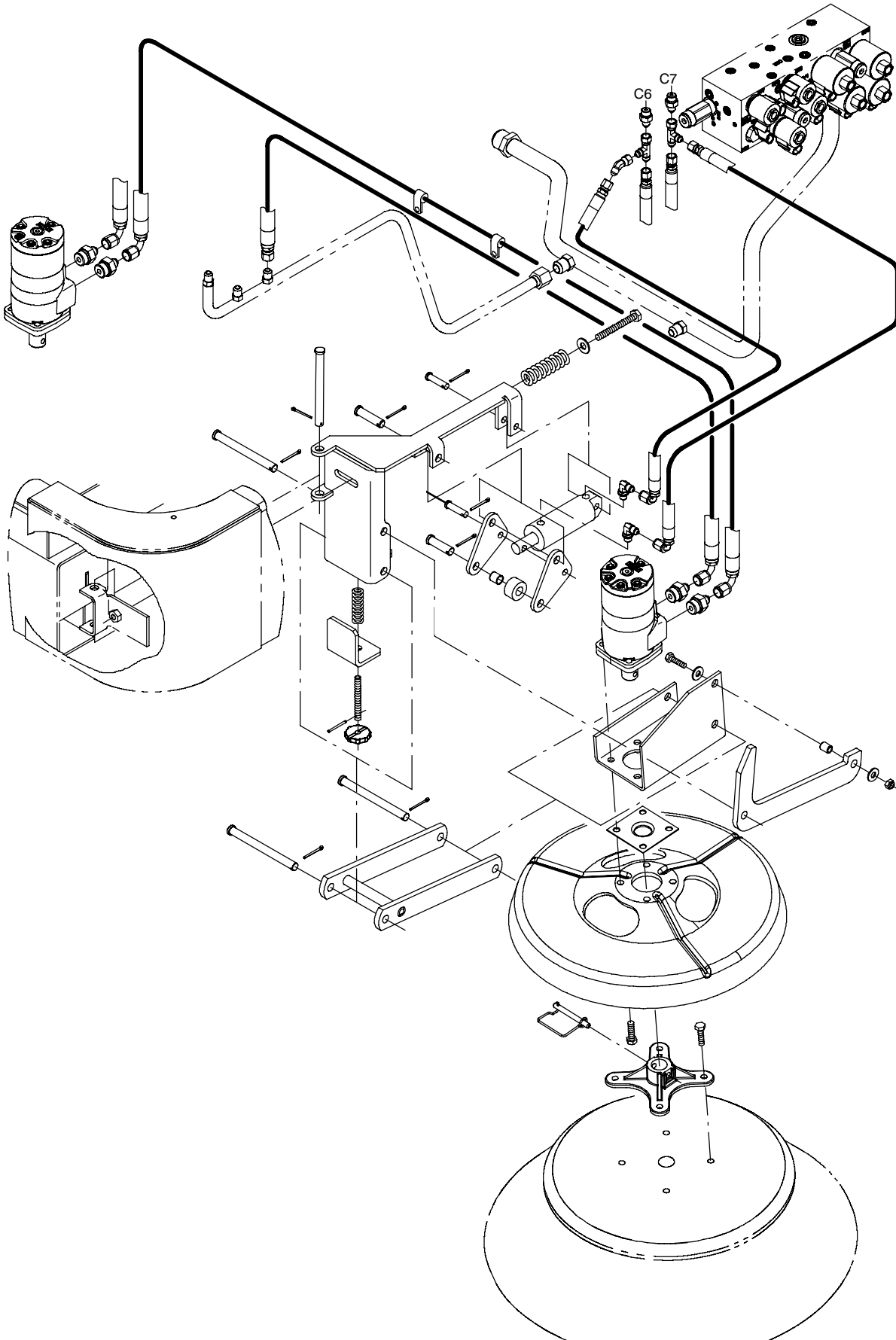

Main Brush ON (S30, S30XP, S30X4)

Conditions: Engine Running, Main Brush Lowered, Hopper Down

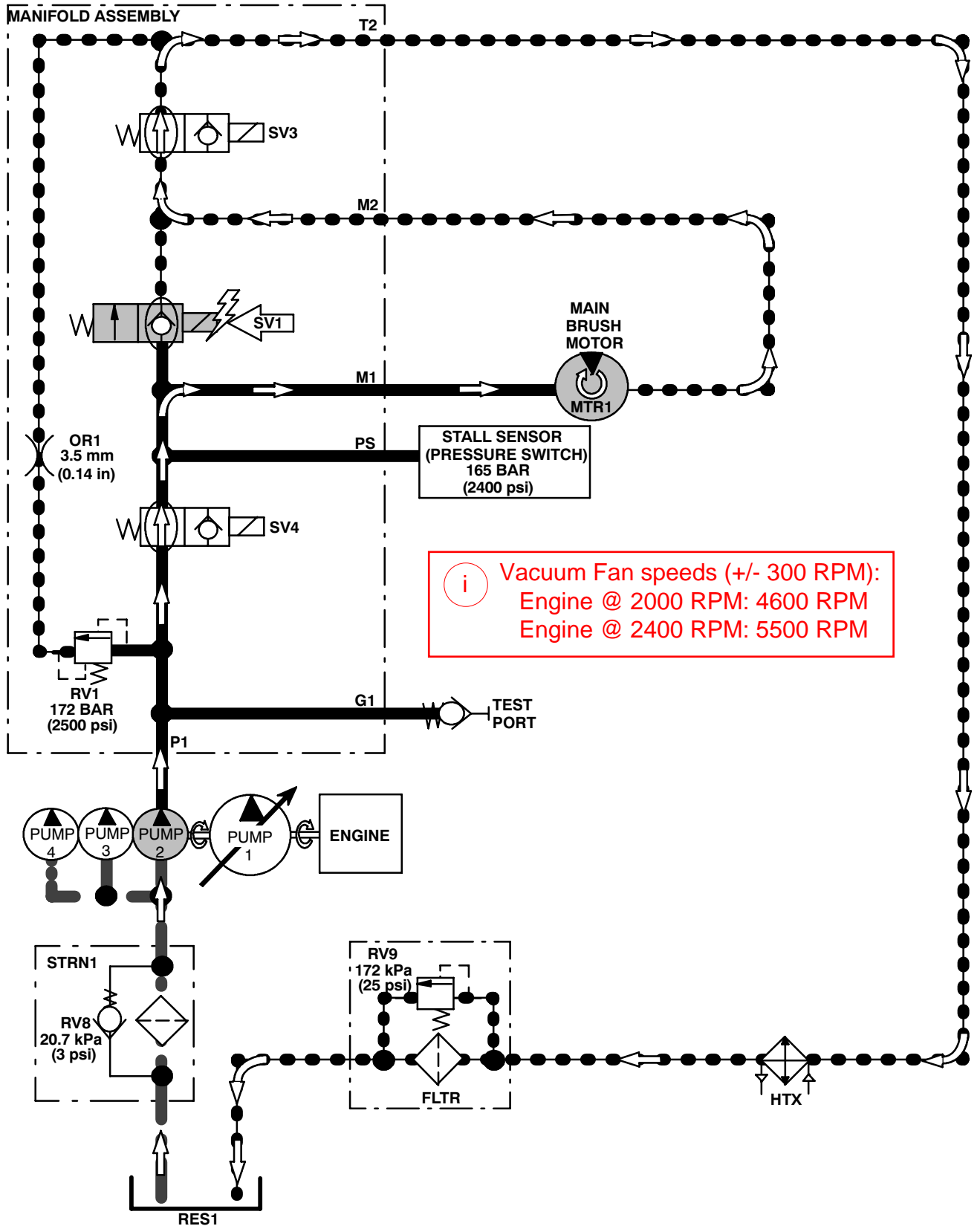

Main Brush & Side Brush(es) ON (S30, S30XP, S30X4)

Conditions: Engine Running, Sweep System Activated, Side Brush(es) Lowered, Hopper Down

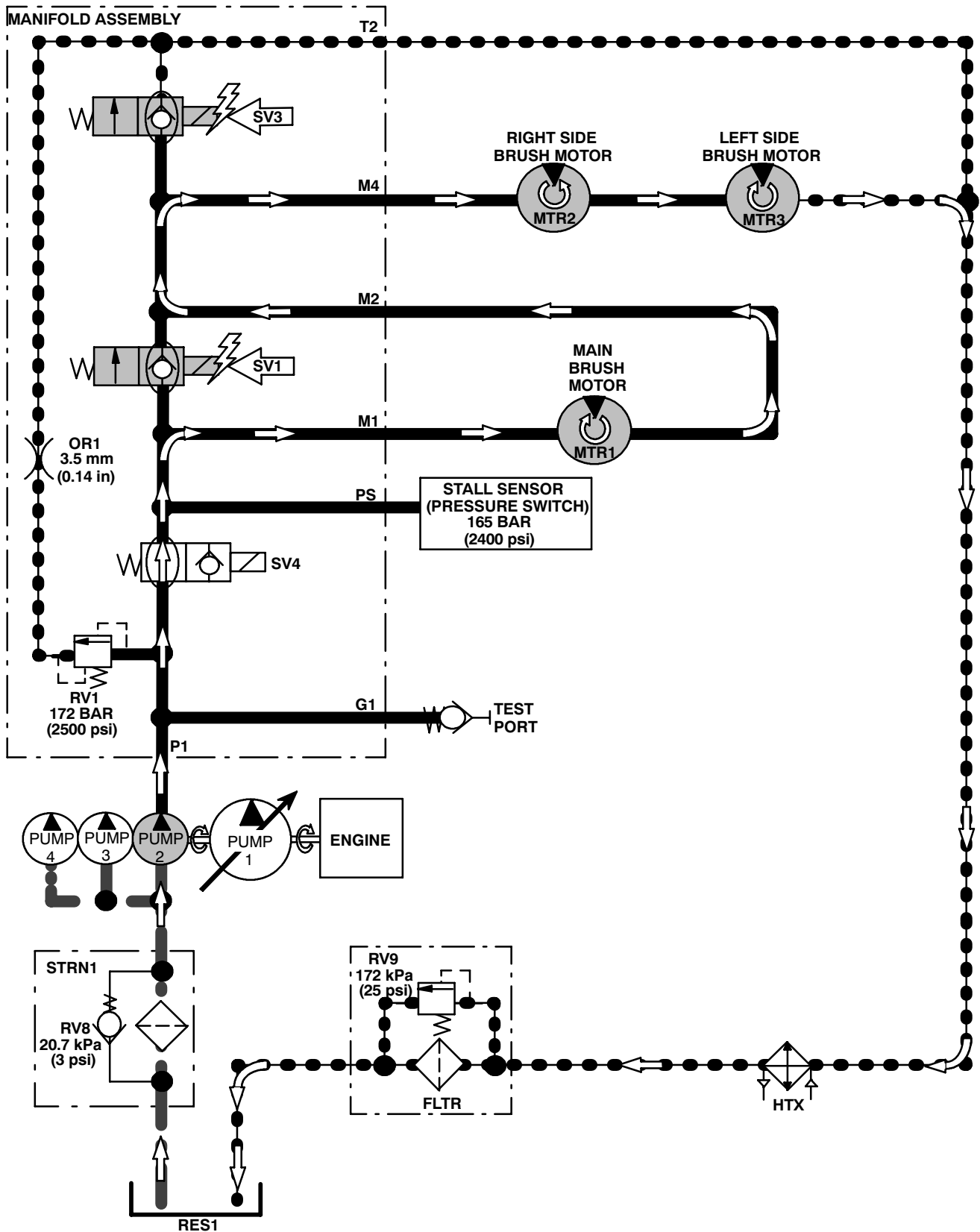

Hopper Door Open (S30, S30XP, S30X4)

Conditions: Engine Running, Hopper Door Switch in OPEN Position

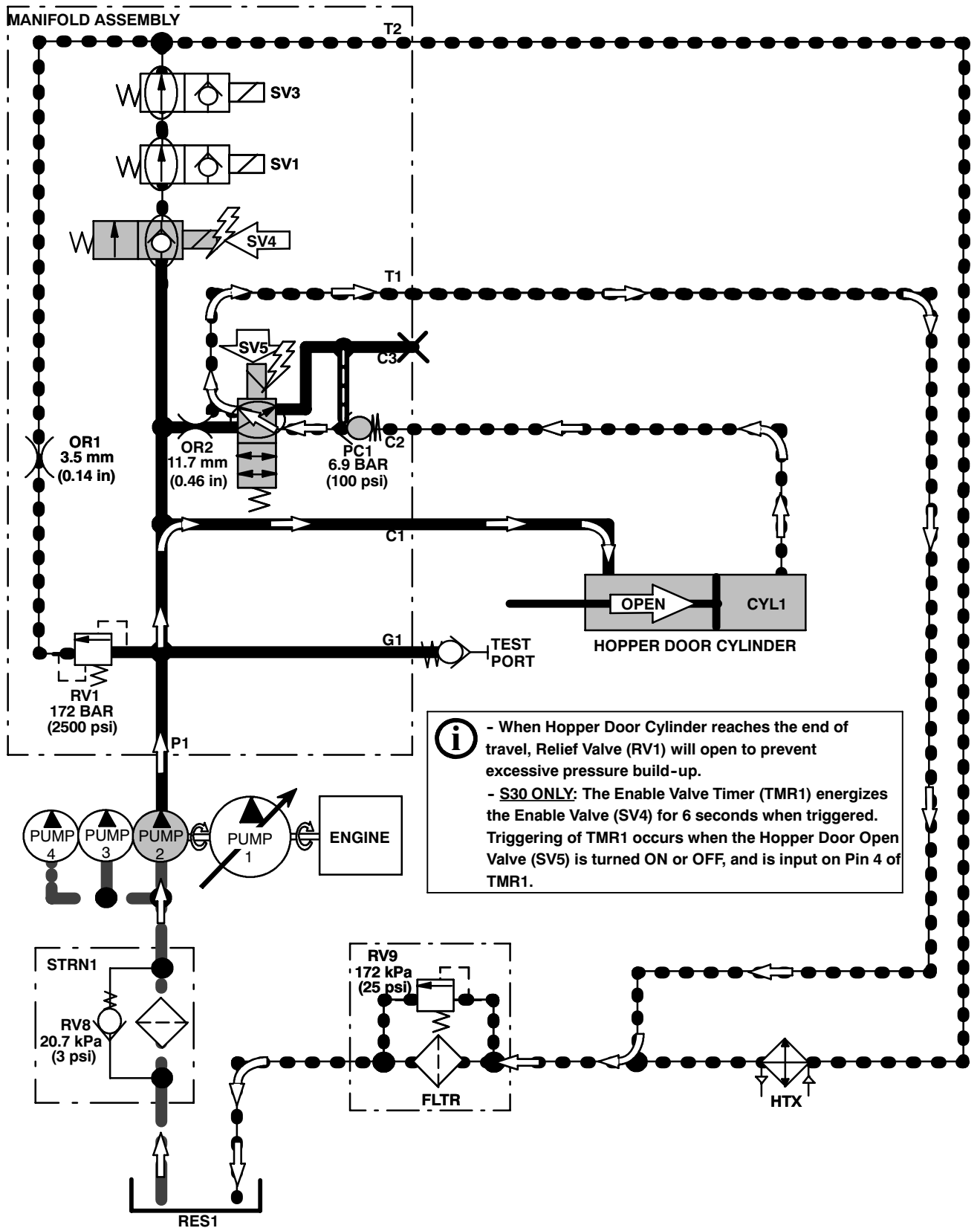

i - When Hopper Door Cylinder reaches the end of travel, Relief Valve (RV1) will open to prevent excessive pressure build-up.
 - **S30 ONLY:** The Enable Valve Timer (TMR1) energizes the Enable Valve (SV4) for 6 seconds when triggered. Triggering of TMR1 occurs when the Hopper Door Open Valve (SV5) is turned ON or OFF, and is input on Pin 4 of TMR1.

Hopper Door Close (S30, S30XP, S30X4)

Conditions: Engine Running, Main Brush Raised, Hopper Door Switch in CLOSE or AUTO Position

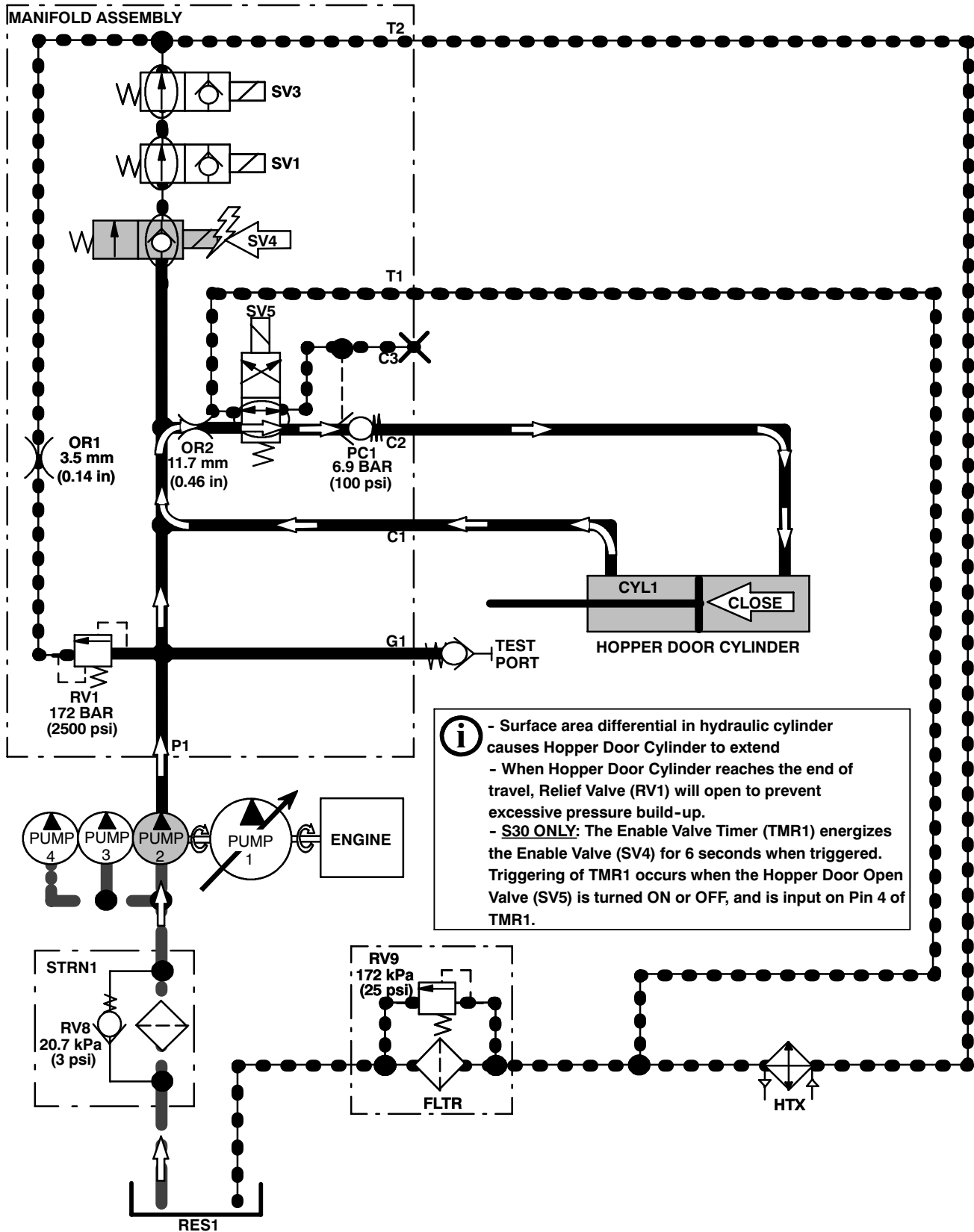

Hopper Lift (S30, S30XP, S30X4)

Conditions: Engine Running, Hopper Lift Switch in RAISE Position

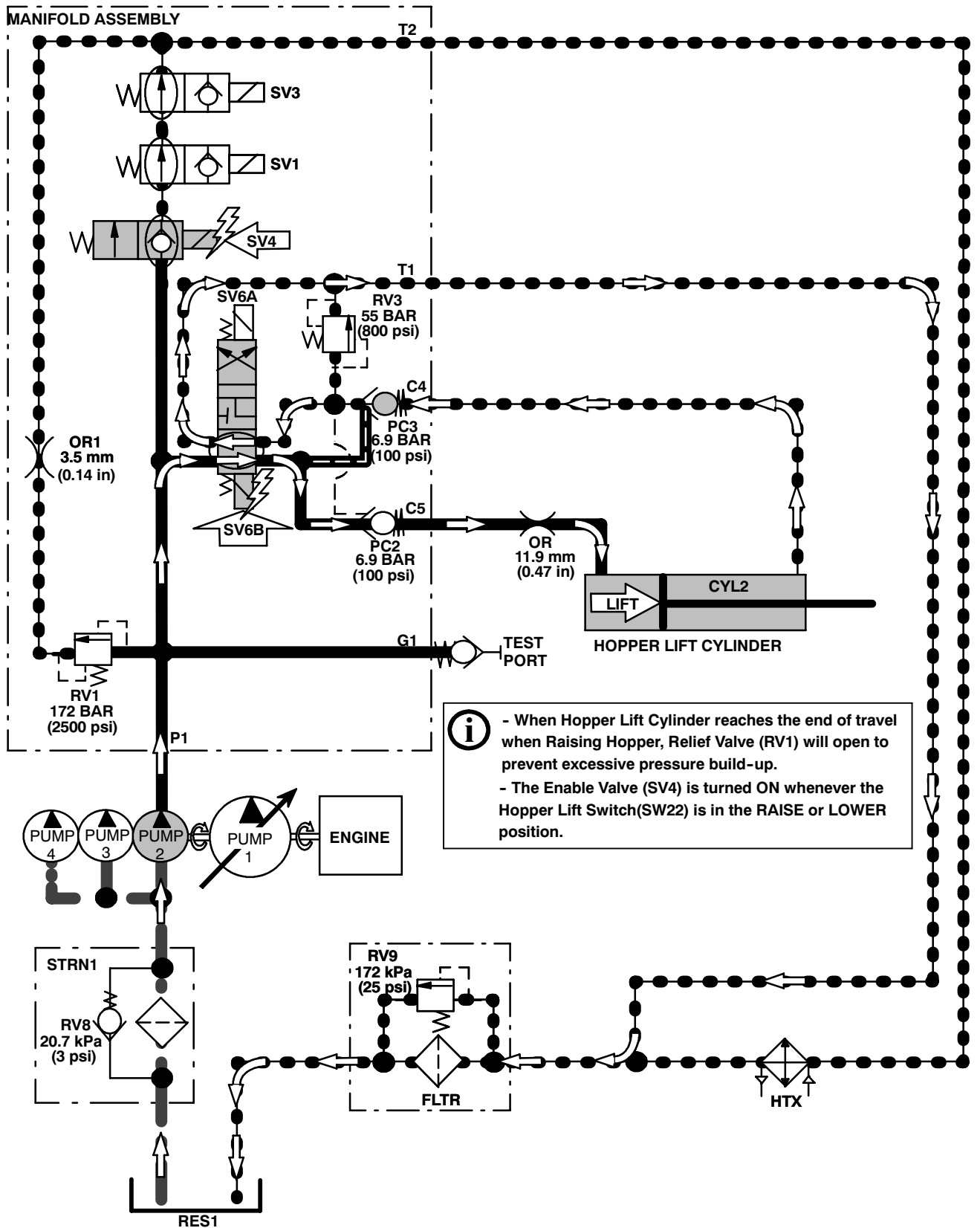

Hopper Lower (S30, S30XP, S30X4)

Conditions: Engine Running, Hopper Lift Switch in LOWER Position

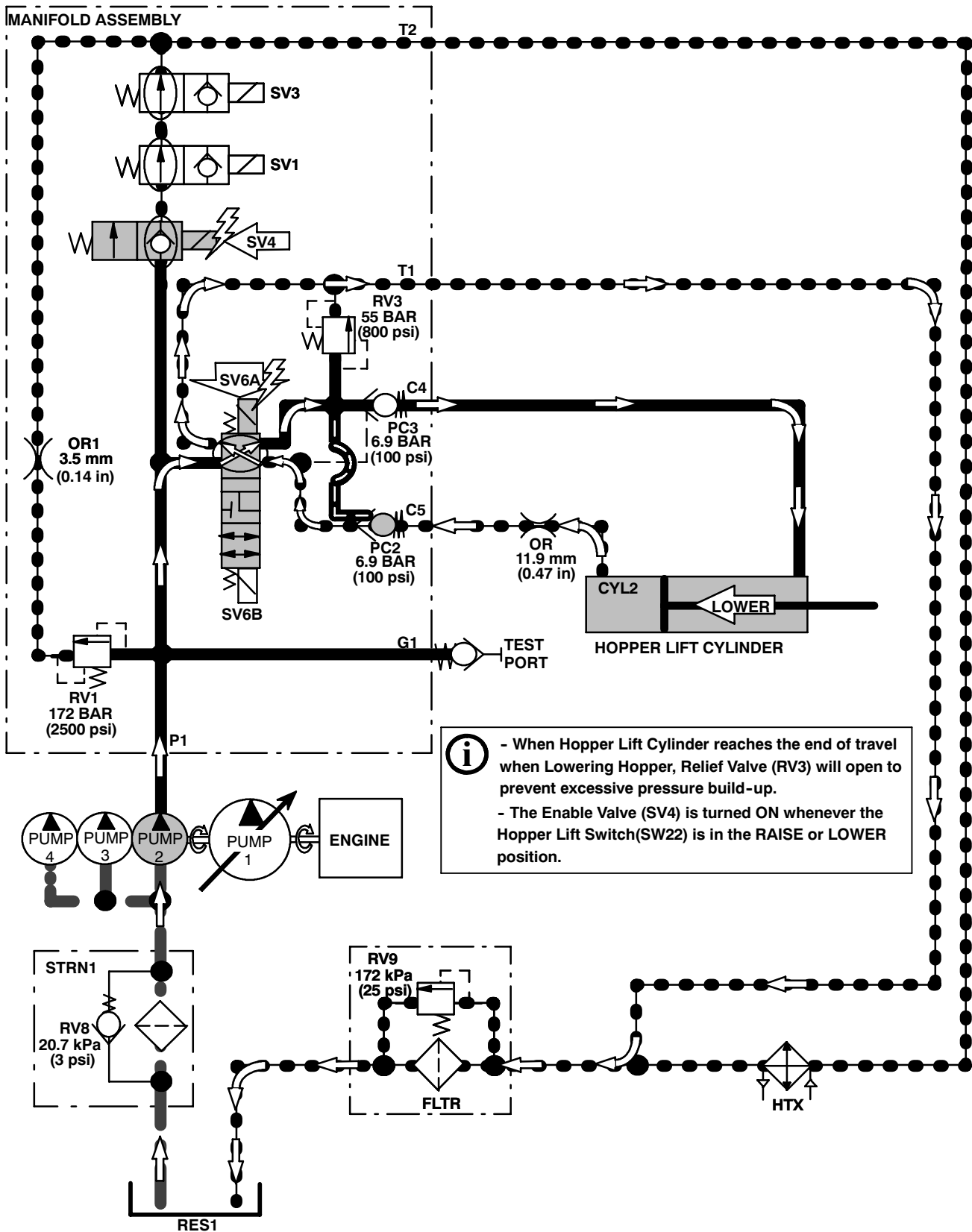

Vacuum Fan ON (S30, S30XP, S30X4)

Conditions: Engine Running, Sweep System Activated, Vacuum System ON

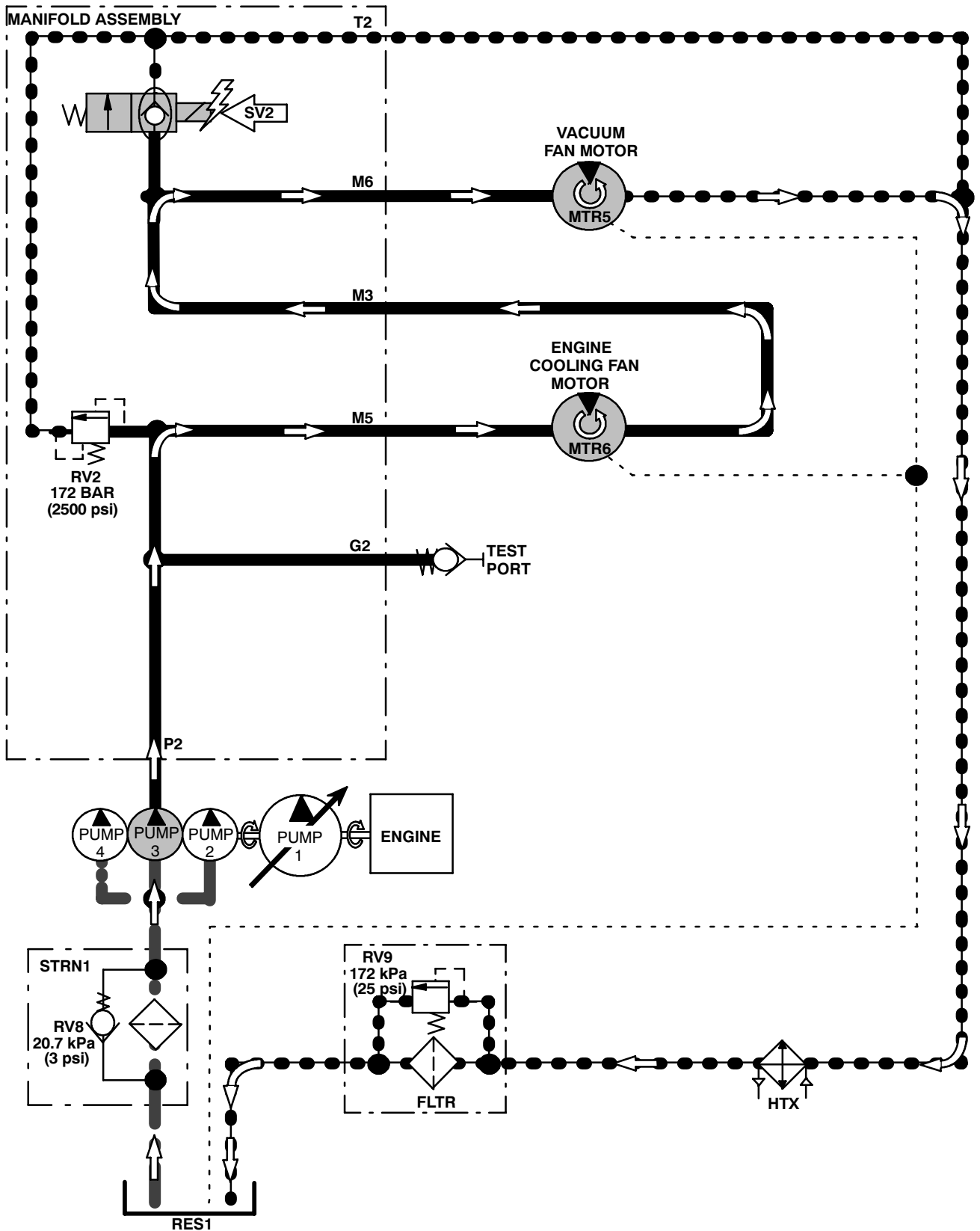

Main Brush Lower (S30XP, S30X4)

Conditions: Engine Running, Sweep System Activated, Vacuum Fan OFF

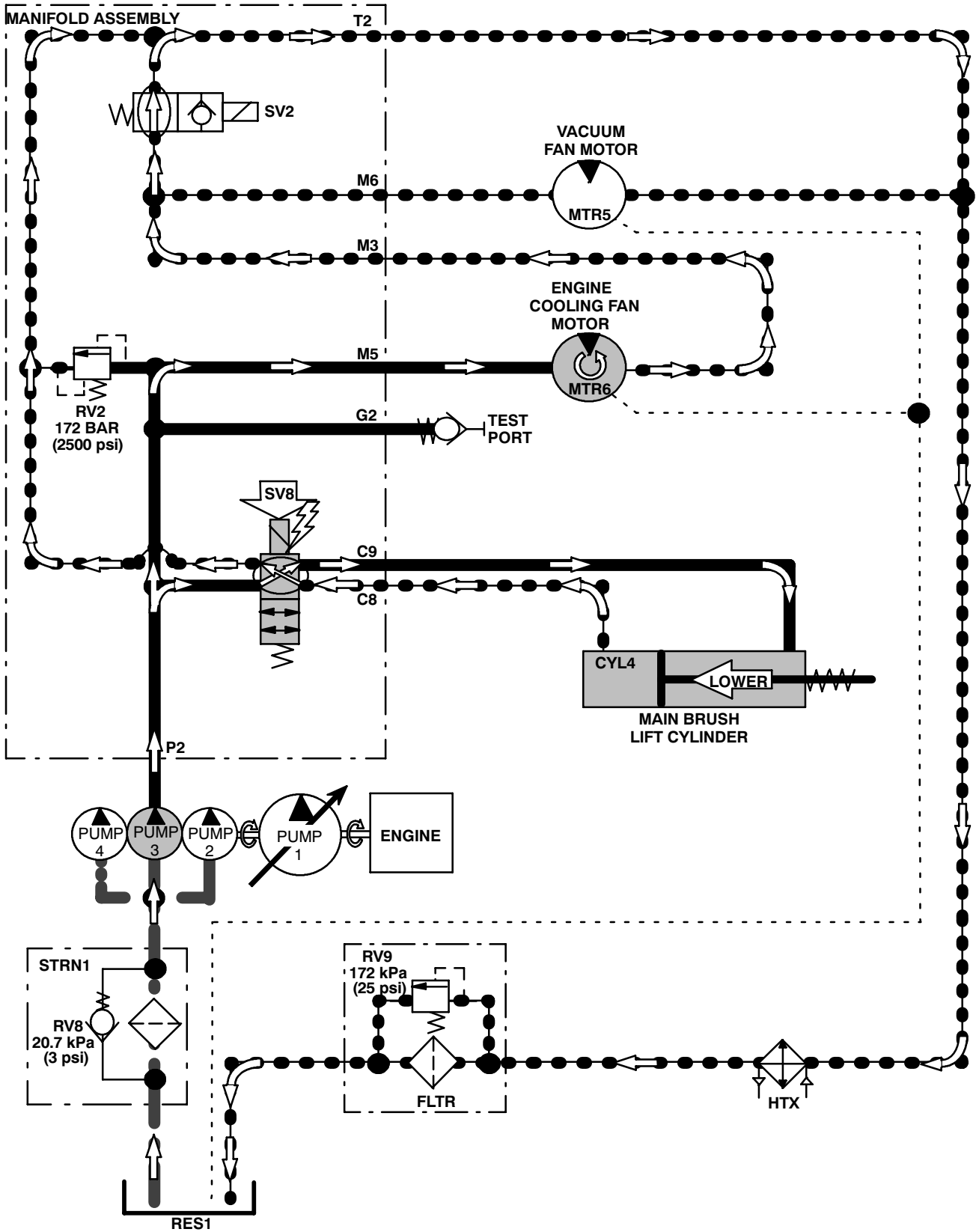

Main Brush & Side Brush(es) Lower (S30XP, S30X4)

Conditions: Engine Running, Sweep System Activated, Side Brush(es) Activated, Vacuum Fan OFF

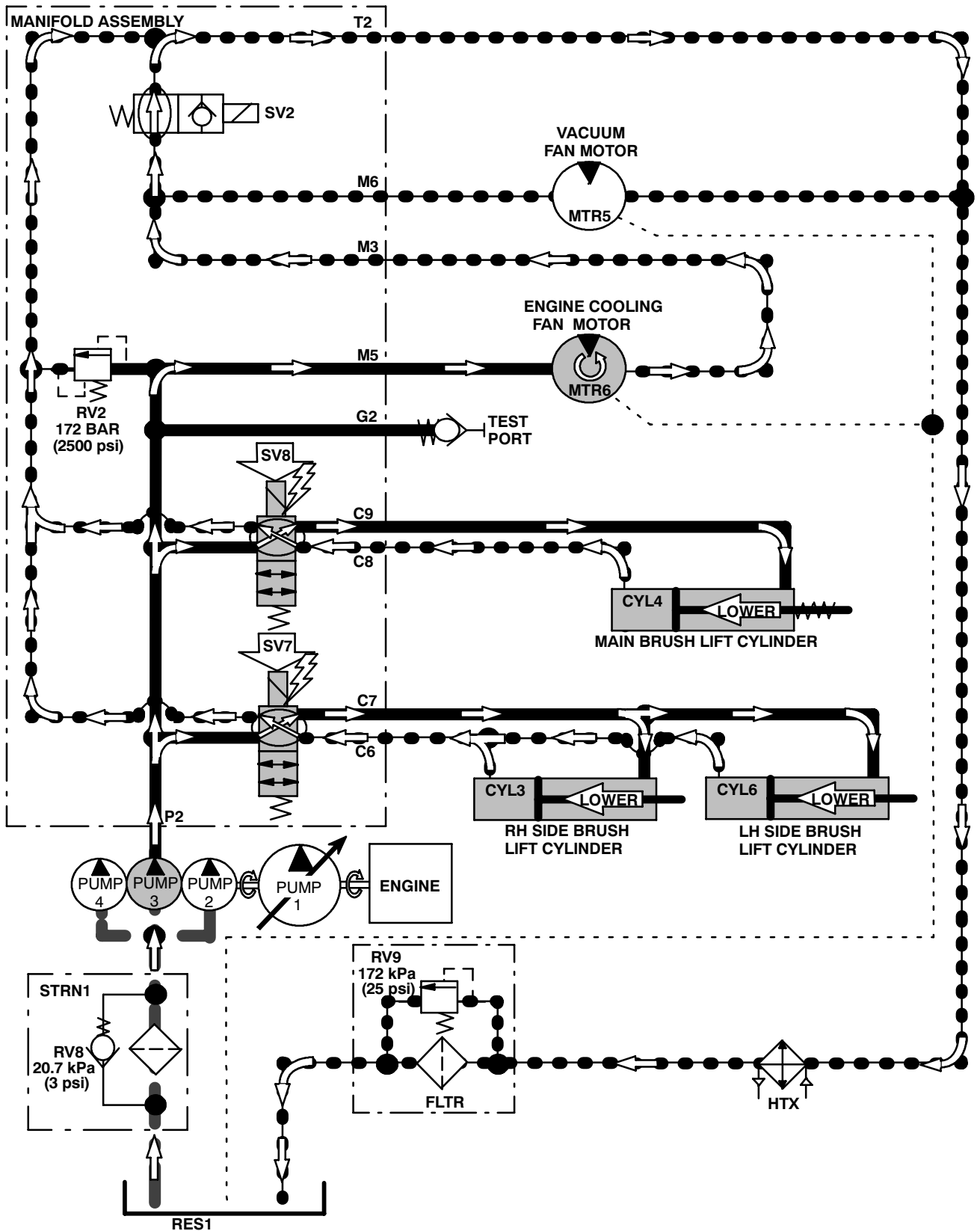

3-Wheel Steering System (S30, S30XP)

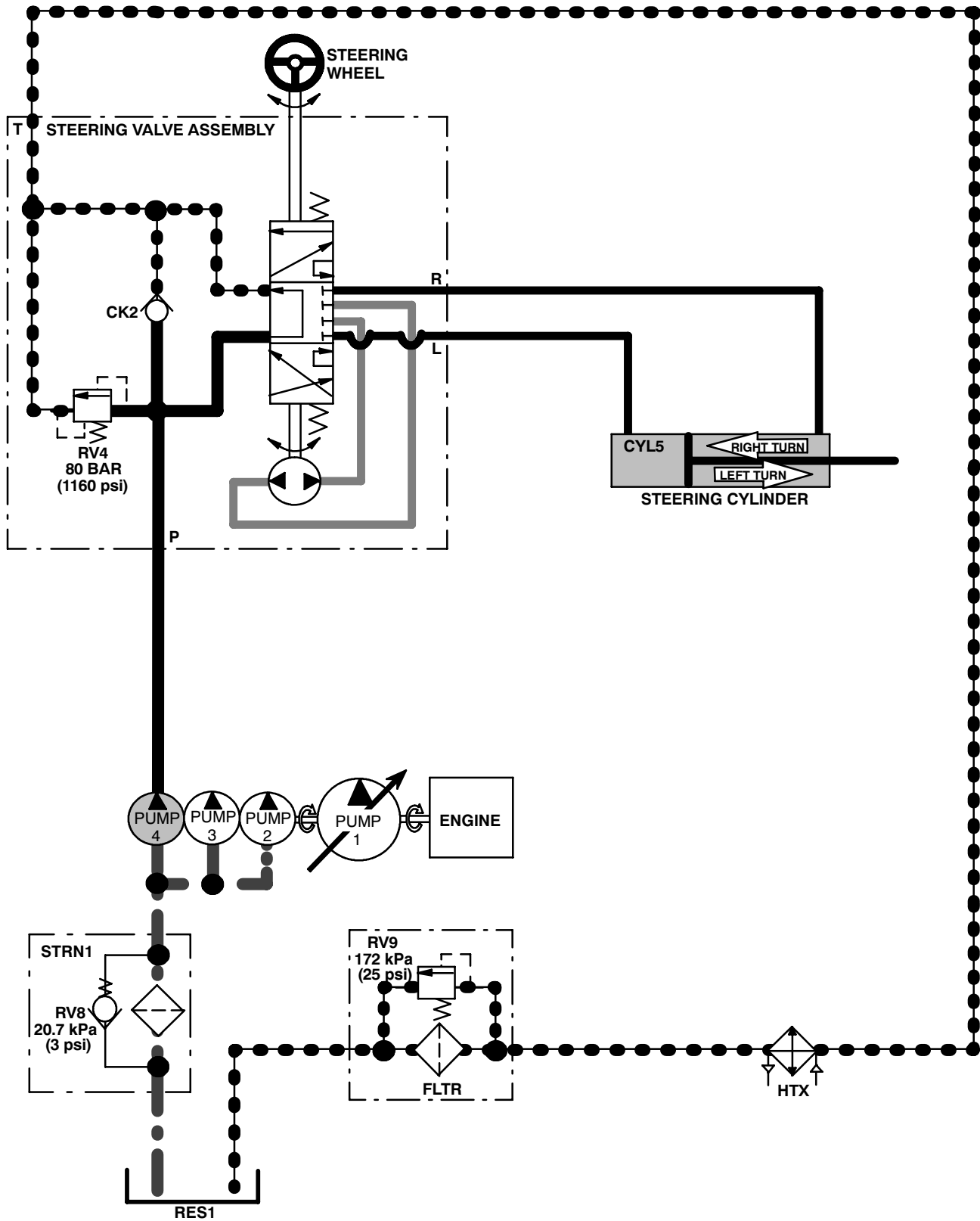

4-Wheel Steering System (S30X4)

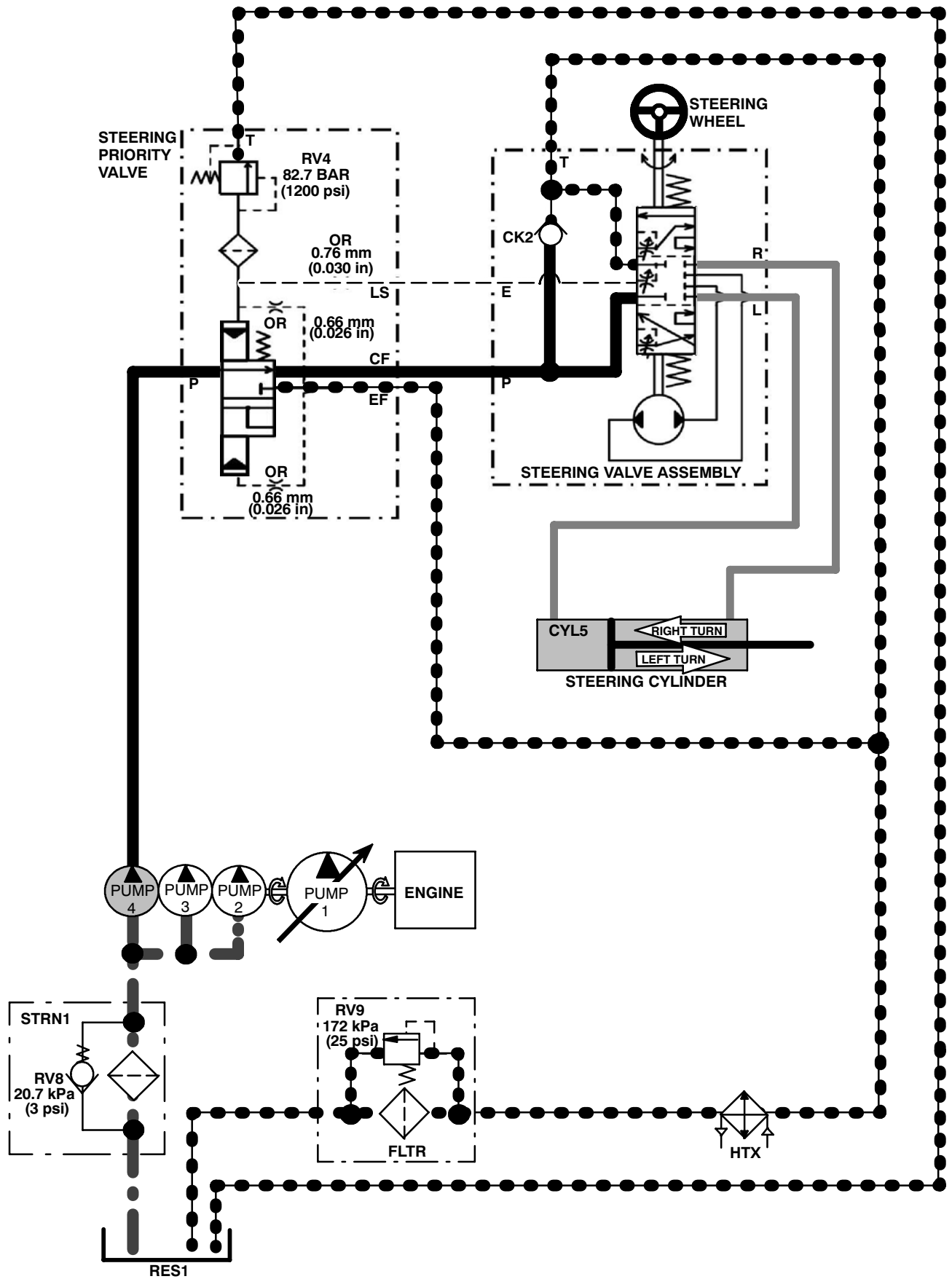

3-Wheel Propel System (S30, S30XP)

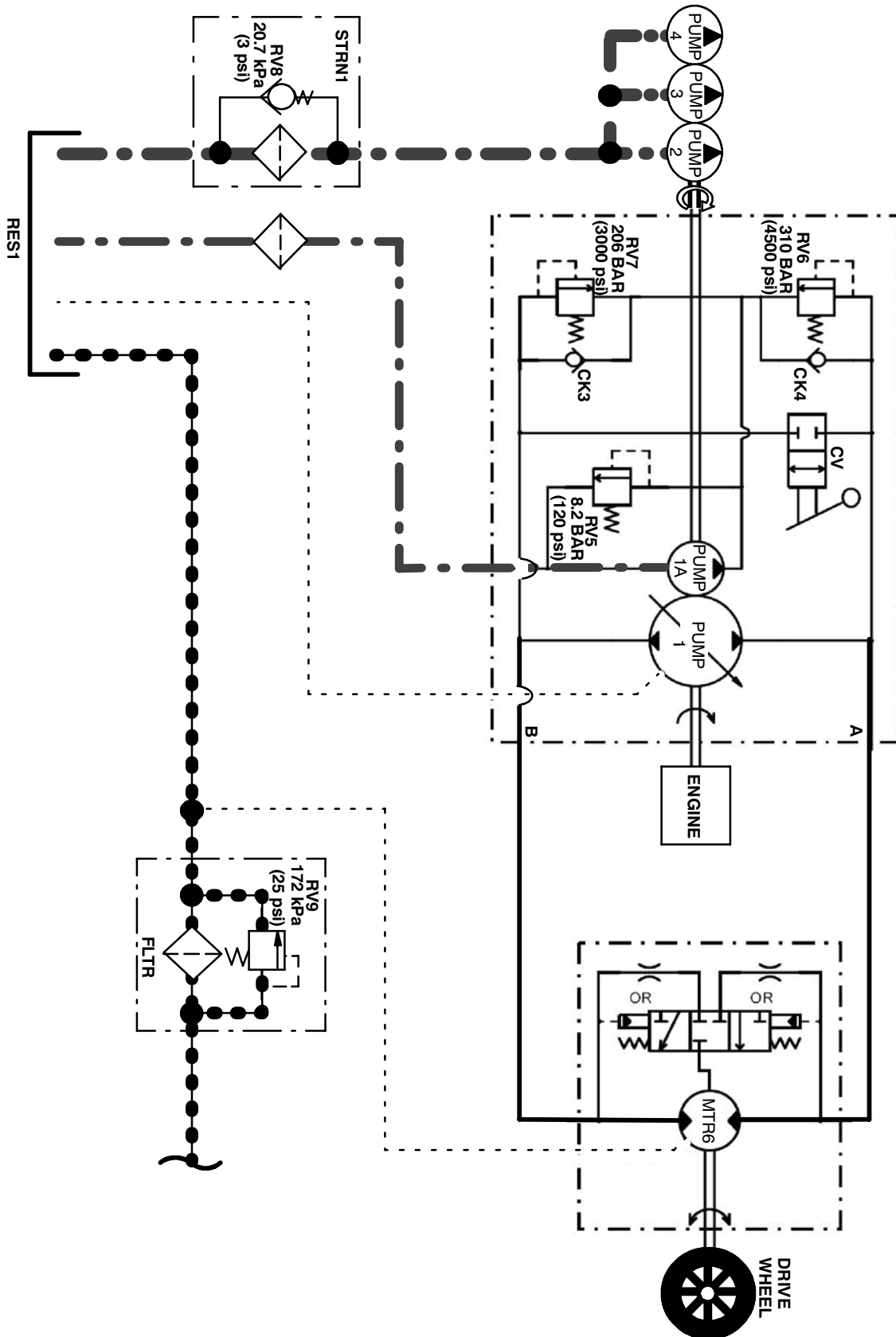

H

4-Wheel Propel System (S30X4)

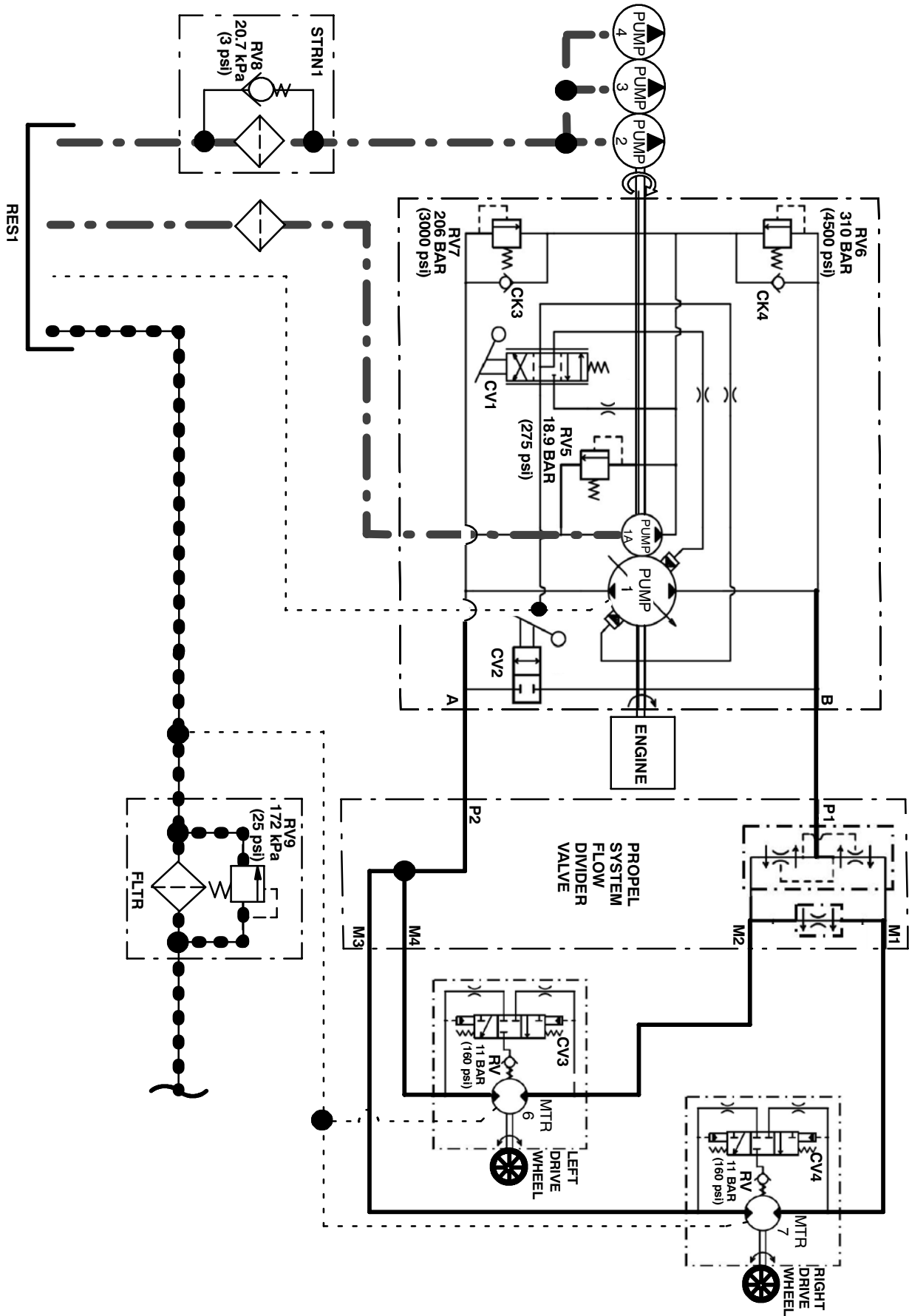



TENNANT COMPANY
 Technical Publications #15
 701 North Liliac Drive
 P.O. Box 1452
 Minneapolis, MN 55440-9947

POSTAGE WILL BE PAID BY ADDRESSEE

BUSINESS REPLY MAIL
 FIRST CLASS MAIL PERMIT NO. 94 MINNEAPOLIS, MN

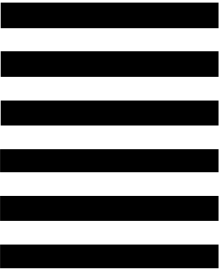

NO POSTAGE
 NECESSARY
 IF MAILED
 IN THE
 UNITED STATES

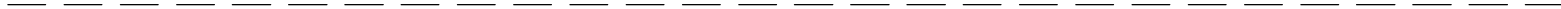
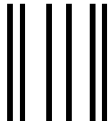

Fold along dotted lines

Tape here





TENNANT COMPANY
 Technical Publications #15
 701 North Liliac Drive
 P.O. Box 1452
 Minneapolis, MN 55440-9947

POSTAGE WILL BE PAID BY ADDRESSEE

BUSINESS REPLY MAIL
 FIRST CLASS MAIL PERMIT NO. 94 MINNEAPOLIS, MN

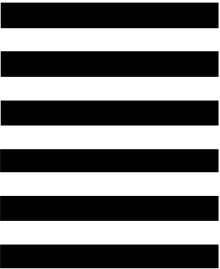

NO POSTAGE
 NECESSARY
 IF MAILED
 IN THE
 UNITED STATES

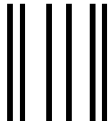

Fold along dotted lines

Tape here

