

TASKI

swingo 150B

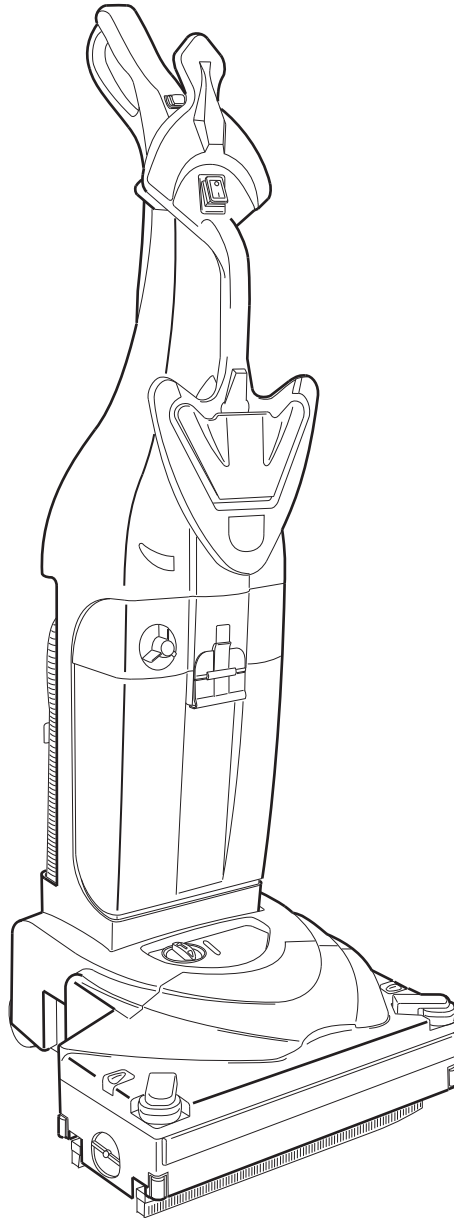

BG . 2	ET . 86	IT ... 169	PT . 251	ZH . 334
CS . 16	FI ... 99	LT .. 183	RO . 265	
DA . 30	FR . 113	LV . 197	SK . 279	
DE . 44	GR . 127	NL . 210	SL .. 293	
EN . 58	HR . 141	NO . 224	SV . 306	
ES . 72	HU . 155	PL . 237	TR . 320	



BG
CS
DA
DE
EN
ES
ET
FI
FR
GR
HR
HU
IT
LT
LV
NL
NO
PL
PT
RO
SK
SL
SV
TR
ZH

EO декларация за съответствие	EU Vaatimustenmukaisuusvakuutus	EUkonformitetserklæringen	ES vyhlášení o zhode
Prohlášení o shodě EU	Déclaration de conformité UE	Deklaracja zgodności EU	AB Uygunluk Beyanı
EU-overensstemmelseserklæring	EU izjava o skladnosti	Declaração de Conformidade da UE	Izjava o usaglašenosti sa standardima EU
EG-Konformitätserklärung	EK-megfelelőségi nyilatkozat	Declarație de conformitate	
Δήλωση συμμόρφωσης EK	Dichiarazione di Conformità UE	Заявление о соответствии стандартам ЕС	
EU Declaration of Conformity	EK atilistības deklarācija		
EÜ vastavusdeklaratsioon	EB atitikties deklaracija	EU-konformitetsförklaringen	
Declaración de Conformidad UE	EU-conformiteitsverklaring	Izjava EU o skladnosti	

Product: **Scrubber drier for commercial use swingo 150B**

Type: **CO150B.5**

Serial Number: **Refer to the rating label on the machine**

Trademark:



Manufacturer

Diversey Europe Operations B.V., Maarssebroeksedijk 2, NL - 3542 DN Utrecht

Produced by

Lindhaus SRL, Via Belgio 22 Zona Ind., 35127 Padova - Italy



BG Декларираме, че посочените по-горе модели са произведени съгласно следните директиви и стандарти. При изменение на продукта, което не е съгласувано с нас, тази декларация губи своята валидност.

CZ Tímto prohlašujeme, že výše uvedené modely byly vyrobeny ve shodě s následujícími směrnici a normami. V případě změny výrobku, která nebyla námi odsouhlasena, ztrácí toto prohlášení svou platnost.

DA Hermed erklærer vi, at ovenstående modeller er blevet fremstillet i henhold til følgende retningslinjer og standarder. I tilfælde af ændringer af produktet, som vi ikke har godkendt, bortfalder gyldigheden af denne erklæring.

DE Hiermit erklären wir, dass die oben erwähnten Modelle gemäß den folgenden Richtlinien und Normen hergestellt wurden. Bei einer nicht mit uns abgestimmten Änderung des Produktes verliert diese Erklärung ihre Gültigkeit.

EL Με την παρούσα δηλώνουμε ότι τα παραπάνω αναφερόμενα μοντέλα έχουν κατασκευαστεί σύμφωνα με τις ακόλουθες Οδηγίες και τα ακόλουθα πρότυπα. Σε περίπτωση τροποποίησης του προϊόντος χωρίς τη συγκατάθεσή μας, η παρούσα δήλωση θα καταστεί άκυρη.

ET Käesolevaga kinnitame, et ülalpool nimetatud mudelid on toodetud vastavuses järgmistele direktiivide ja standarditega. Käesolev kinnitus kaotab kehtivuse, kui toode muudetakse meiega kooskõlastamata.

EN We herewith declare that the aforementioned models were manufactured in accordance with the following guidelines and standards. In the event of a product amendment which was not cleared by us, this declaration shall no longer be valid.

ES Por la presente, declaramos que los modelos arriba indicados fueron fabricados conforme a las siguientes directivas y normas. En caso de realizar una modificación no autorizada por nosotros, esta declaración pierde su validez.

FI Täten vakuutamme, että yllä mainitut mallit on valmistettu seuraavien direktiivien ja normien mukaisesti. Mikäli tuotetta muutetaan ilman meidän antamaa lupaa, tämä ilmoitus lakkaa olemasta voimassa.

FR Nous déclarons par la présente que les modèles susmentionnés ont été fabriqués selon les directives et normes suivantes. Cette déclaration perd sa validité si le produit est modifié sans notre consentement.

HR Ovime izjavljujemo da smo gore navedene modele proizveli prema sljedećim direktivama i normama. U slučaju neovlaštene izmjene proizvoda prestaje valjanost ove izjave.

HU Ezennel kijelentjük, hogy a fent említett modellek az alábbi előírásoknak és szabványoknak megfelelően készültek. Amennyiben olyan módosítás történik a terméken, amelyet előzetesen nem egyeztettek velünk, akkor a jelen nyilatkozat érvényét veszti.

IT Con la presente dichiariamo che i modelli citati sopra sono stati realizzati conformemente alle seguenti norme e direttive. In caso di modifica del prodotto senza la nostra autorizzazione, questa dichiarazione non sarà più valida.

LV Ar šo apliecinām, ka iepriekš minētie modeļi ir izgatavoti atbilstoši šādām direktīvām un normatīviem. Ja tiek veikta ar mums nesaskaņota izstrādājuma izmaiņošana, šī deklarācija nav derīga.

LT Pareiškiamo, kad minėti modeliai buvo pagaminti vadovaujantis nurodytomis direktyvomis ir standartais. Ši deklaracija netenka galios, jei gaminys pakeičiamas nesuderinus jo pakeitimų su mumis.

NL Hiermee verklaren we dat de hierboven vermelde modellen in overeenstemming met de volgende richtlijnen en normen worden vervaardigd. In geval van een niet met ons overeengekomen wijziging van het product, verliest deze verklaring haar geldigheid.

NO Vi erklærer herved at de ovennevnte modellene er produsert iht. følgende retningslinjer og standarder. Ved endringer av produkter som ikke er godkjent fra oss, bortfaller denne erklæringen.

PL Niniejszym deklarujemy, że wyżej wymienione modele zostały wyprodukowane zgodnie z niżej wymienionymi dyrektywami i normami. W przypadku dokonania niezgodzonych z nami zmian w produkcji niniejsza deklaracja traci ważność.

PT Por este meio declaramos que os modelos acima mencionados foram fabricados de acordo com as seguintes directivas e normas. Em caso de uma alteração do produto que não tenha sido autorizada por nós, esta declaração perde a sua validade.

RO Prin prezenta declarăm că modelele menționate mai sus, sunt produse în conformitate cu următoarele directive și norme. La o modificare a produsului care nu a fost aprobată de noi în prealabil, această declarație își pierde valabilitatea.

RU Настоящим мы заявляем, что указанные выше модели изготовлены в соответствии с требованиями следующих Директив и стандартов. В случае несогласованного с нами изменения изделия настоящее заявление становится недействительным.

SL Izjavljamo, da so bili zgoraj navedeni modeli izdelani v skladu z navedenimi smernicami in normami. V primeru spremembe izdelka, ki ni bila potrjena z naše s strani, ta izjava ni več veljavna.

SK Týmto vyhlasujeme, že uvedené modely boli vyrobené v zhode s nasledujúcimi smernicami a normami. V prípade zmeny výrobku, ktorá s nami nebola konzultovaná, stráca toto vyhlásenie svoju platnosť.

SV Härmed förklarar vi att ovan nämnda modell uppfyller följande riktlinjer och normer. Vid av oss ej godkända ändringar på produkten upphör denna förklaring att gälla.

TR Yukarıda belirtilen modellerin aşağıdaki yönergelere ve standartlara uygun olduğunu beyan ederiz. Üründe yapılan herhangi bir değişiklikle bu beyanı geçersiz kılar.

YU Ovim putem izjavljujemo da su gore navedeni modeli proizvedeni u skladu sa sledećim smernicama i standardima. U slučaju izmena na proizvodu koje nisu dogovorene s nama, ova izjava ne važi.

Applicable EU Directives:

Directive 2006/42/EC | Directive 2014/30/EU

Harmonised standards:

EN 60335-1: 2012+A11: 2014 / EN 60335-2-69: 2012 / EN 62233: 2008 / EN 55014-1: 2006+A1: 2009+A2: 2011 / EN 55014-2: 2015 / EN 61000-3-2: 2014 / EN 61000-3-3: 2013 /

BG	Предприети са вътрешни мерки, за да се гарантира, че продуктите винаги съответстват на изискванията на най-новите регламенти на ЕС и стандартите, които са действащи в момента.	FR	Des mesures internes ont été prises pour garantir que les produits répondent toujours aux exigences des règlements les plus récents de l'UE et aux normes actuellement en vigueur.	PT	Foram tomadas medidas internas para assegurar que os produtos cumprem sempre os requisitos dos mais recentes regulamentos da UE e os padrões actualmente em vigor.
CZ	Byla přijata interní opatření, jejichž cílem je zabezpečit, aby výrobky vždy odpovídaly požadavkům nejnovějších pravidel EU a norem, které jsou v současnosti používány.	HR	Poduzete su interne mjere koje osiguravaju da proizvodi uvijek ispunjavaju zahtjeve najnovijih propisa i trenutno važećih normi EU-a.	RO	S-au luat măsuri interne pentru a asigura faptul că produsele corespund întotdeauna cerințelor ultimelor directive UE și normelor în vigoare.
DA	Der skal træffes interne foranstaltninger for at sikre, at produktet altid lever op til kravene i de nyeste EU-direktiver og de gældende standarder.	HU	A vállalaton belül meg tettük a megfelelő intézkedéseket, hogy a termék minden esetben megfeleljenek a legújabb uniós előírásoknak és az aktuálisan használatban lévő szabványoknak.	RU	Внутренние меры приняты с целью обеспечения постоянного соответствия изделий требованиям последних директив ЕС и применяющихся в настоящее время стандартов.
DE	Es wurden interne Massnahmen ergriffen, um sicherzustellen, dass die Produkte in jedem Fall den Anforderungen der aktuellen EU-Vorschriften sowie den aktuell geltenden Normen entsprechen.	IT	Sono state prese misure interne per assicurare che i prodotti siano sempre conformi ai requisiti degli ultimi regolamenti UE e agli standard attualmente vigenti.	SL	S sprejetimi notranjimi ukrepi zagotavljamo, da so izdelki vedno v skladu s predpisi EU in trenutno veljavnimi standardi.
EL	Έχουν ληφθεί εσωτερικά μέτρα, προκειμένου να διασφαλιστεί ότι τα προϊόντα θα πληρούν πάντα τις απαιτήσεις των πιο πρόσφατων Κανονισμών της ΕΕ και των εφαρμοζόμενων προτύπων.	LV	Izstrādājumu pastāvīga atbilstība jaunāko EK normatīvu un spēkā esošo standartu prasībām tiek nodrošināta, veicot iekšējos pasākumus.	SK	Prijali sa interné opatrenia, ktorých cieľom je zabezpečiť, aby výrobky vždy zodpovedali požiadavkám najnovších pravidiel EÚ a noriem používaných v súčasnosti.
ET	Selleks, et alati tagada toodete vastavus uusimate ELi määruste ja praegu kehtivate standarditega, on võetud sisemeetmeid.	LT	Buvo imtasi vidaus priemonių siekiant užtikrinti, kad gaminiai visuomet atitiktų naujausių ES reglamentų ir šiuo metu taikomų standartų reikalavimus.	SV	Interna åtgärder har vidtagits för att försäkra att produkterna alltid uppfyller kraven i de senaste EU-bestämmelserna och de aktuella standardmåtten.
EN	Internal measures have been taken to ensure that the products always correspond to the requirements of the latest EU Regulations and the standards that are currently in use.	NL	Er werden interne maatregelen genomen om te verzekeren dat de producten steeds in overeenstemming zijn met de vereisten van de laatste EU-verordeningen en de normen die momenteel in gebruik zijn.	TR	Ürünün daima son AB Yönergeleri ve yürürlükteki standartların gerekliliklerine uygun olması için dahili önlemler alınmıştır.
ES	Se han adoptado medidas internas para garantizar que los productos siempre cumplen con los requisitos de los últimos reglamentos de la UE y las normas que se aplican actualmente.	NO	Det har blitt implementert interne tiltak for å sikre at produktet alltid er i samsvar med kravene til de nyeste EU-bestemmelsene og standardene som brukes til enhver tid.	YU	Preduzete su interne mere da se obezbedi da proizvodi uvek odgovaraju zahtevima najnovijih propisa EU i standardima koji su trenutno u upotrebi.
FI	Sisäisiä ohjeita ja toimenpiteitä on noudatettu sen varmistamiseksi, että tuote vastaa aina viimeisimpien EU-asetusten vaatimuksia ja voimassaolevia standardeja.	PL	Podjęto wewnętrzne działania w celu zagwarantowania, że produkty będą zawsze spełniać wymagania aktualnie obowiązujących przepisów unijnych i norm.		

Authorized signatory:



Huub Vroomen
Executive Engineering Systems

Utrecht, dated 13.02.2017

Responsible for technical file:

Angelo Sabatino
Mgr Regulatory Affairs
Diversey Europe B.V., Utrecht
Zweigniederlassung Münchwilen
Eschlikonerstrasse
9542 Münchwilen - Switzerland



Sealed Air
Re-Imagine™
Diversey Europe Operations BV
Maarssenbroeksedijk 2
3542 DN Utrecht
The Netherlands

CE first applied: 02.2017

The signatories act on behalf of company management and with full power of attorney.

swingo 150B

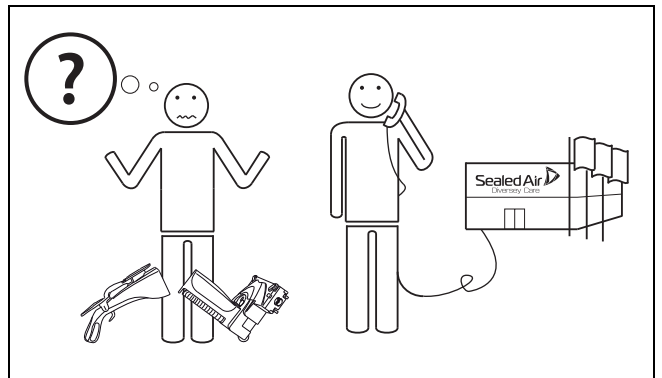
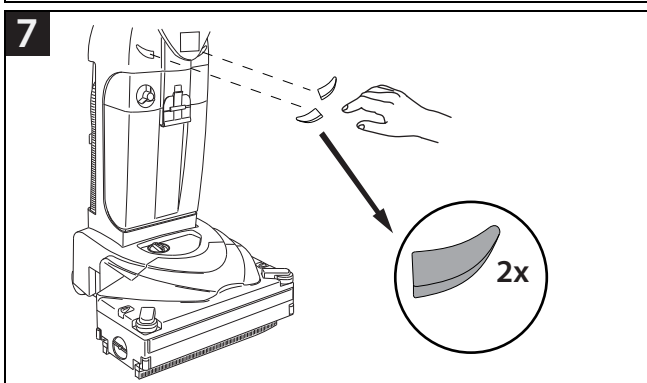
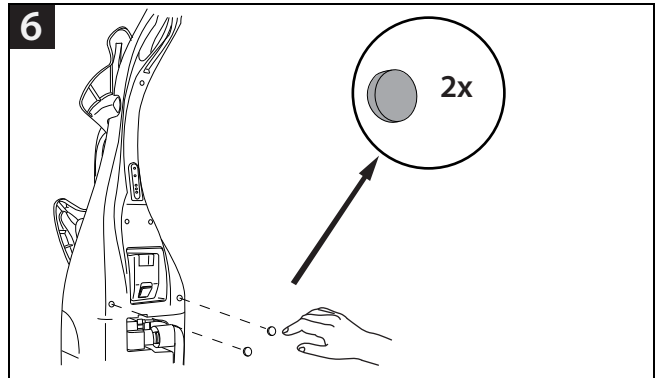
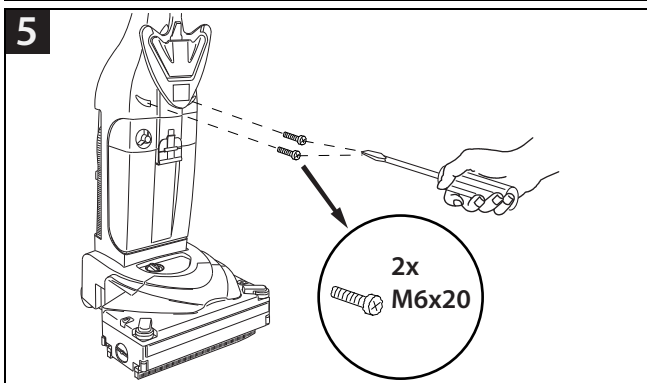
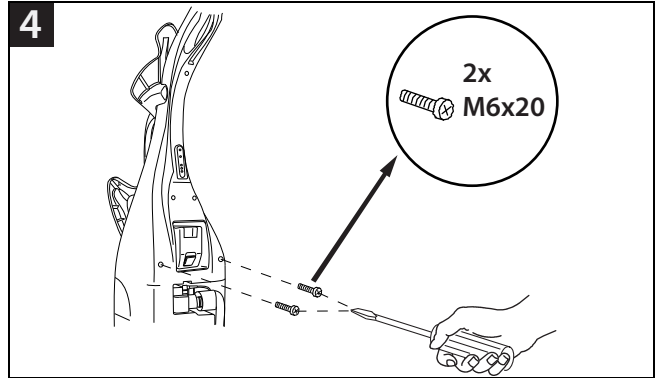
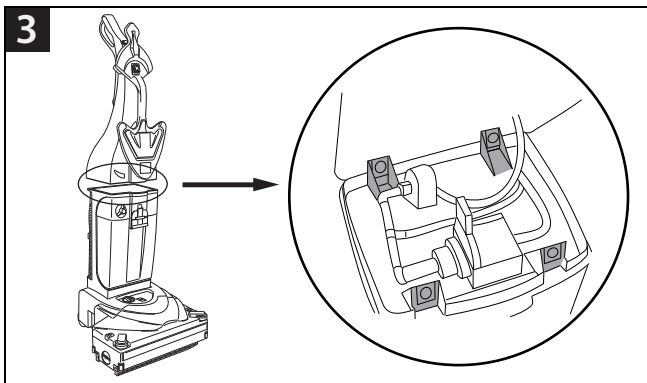
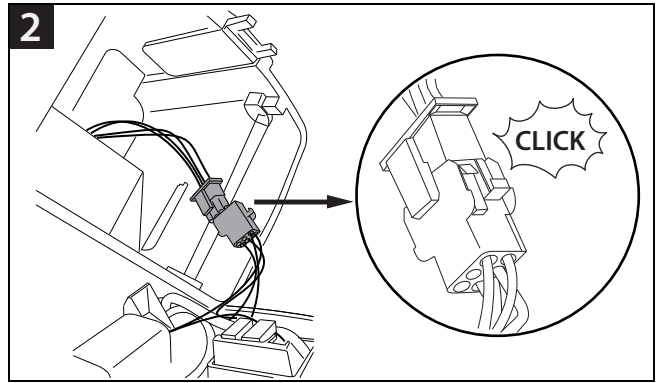
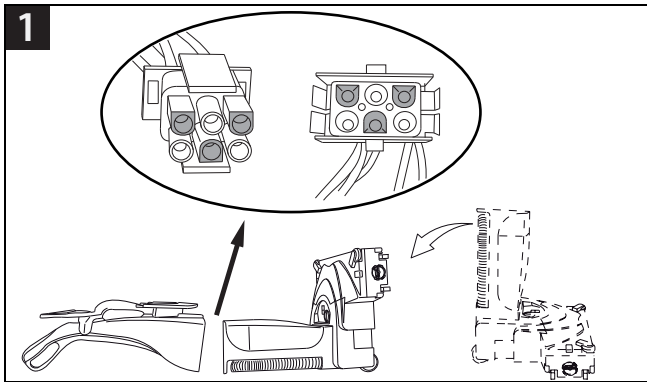

Störungen

Störung	Mögliche Ursache	Behebung der Störung	Seite
Maschine ohne Funktion	Hauptschalter ausgeschaltet	• Hauptschalter einschalten	44
	Batterie entladen	• Batterie laden	46
	Batterie defekt	• Service-Partner kontaktieren	
	Motor dreht nicht	• Service-Partner kontaktieren	
	Hauptschalter defekt	• Service-Partner kontaktieren	
Bürstenwalze dreht sich nicht	Maschine nicht in Arbeitsposition	• Bringen Sie die Maschine in Arbeitsposition	48
	Motor dreht, aber Bürste nicht	• Defekter Antrieb • Service-Partner kontaktieren	
Schlechte Saugleistung	Motorschutzfilter verschmutzt	• Motorschutzfilter reinigen oder ersetzen	50
	Saugschlauch nicht richtig eingesetzt	• Saugschlauch kontrollieren und allenfalls korrekt einstecken	

Technische Informationen

Maschine		
Arbeitsbreite	34	cm
Breite der Saugdüse	36	cm
Masse (L x B x H)	43 x 38 x 112	cm
Maschinengewicht betriebsbereit maximal	13	kg
Nennspannung	36 V	DC
Nennleistung nominal	520	W
Frischwassertank nominal +/- 5%	2.6	l

Ermittelte Werte gemäss IEC 60335-2-72		
Schalldruckpegel LpA	74	dB(A)
Unsicherheit KpA	3	dB(A)
Schwingungsgesamtwert	<2.5	m/s ²
Unsicherheit K	0.25	m/s ²
Spritzwasserschutz	IPX4	
Schutzklasse	III	

Zubehör

Nr.	Artikel
7516236	Bürstenwalze mittel schwarz
7516237	Bürstenwalze hart rot
7516546	Saugdüsen Set
7519049	Padrolle
7524166	TASKI Lithium-Ionen-Batterie 36 V / 6 Ah
7524167	Batterieladegerät 100-120 V, 60 Hz
7524168	Batterieladegerät 220-240 V, 50/60 Hz
7524169	Batterieladegerät 220-240 V, 50/60 Hz (ohne Netzkabel)

Transport



Hinweis:

Transportieren Sie die Maschine stehend.



Hinweis:

Achten Sie darauf, dass die Maschine im Transportfahrzeug festgesichert und gesichert ist.



Hinweis:

Entfernen Sie die Lithium-Ionen-Batterien bei Lagerung und Transport der Maschine.

Entsorgung



Hinweis:

Die Maschine und Zubehör sind nach Ihrer Ausserbetriebnahme einer fachgerechten Entsorgung gemäss den nationalen Vorschriften zuzuführen. Ihr Diversey-Servicepartner kann Sie dabei unterstützen.

Batterien



Achtung:

Alle Batterien müssen aus der Maschine entfernt werden, bevor diese einer fachgerechten Entsorgung zugeführt wird.

Verbrauchte Batterien sind entsprechend der EU-Richtlinien 2006/66/EG oder den jeweiligen nationalen Vorschriften umweltgerecht zu entsorgen.

Abmessungen der Maschine

Masse sind in Zentimeter!

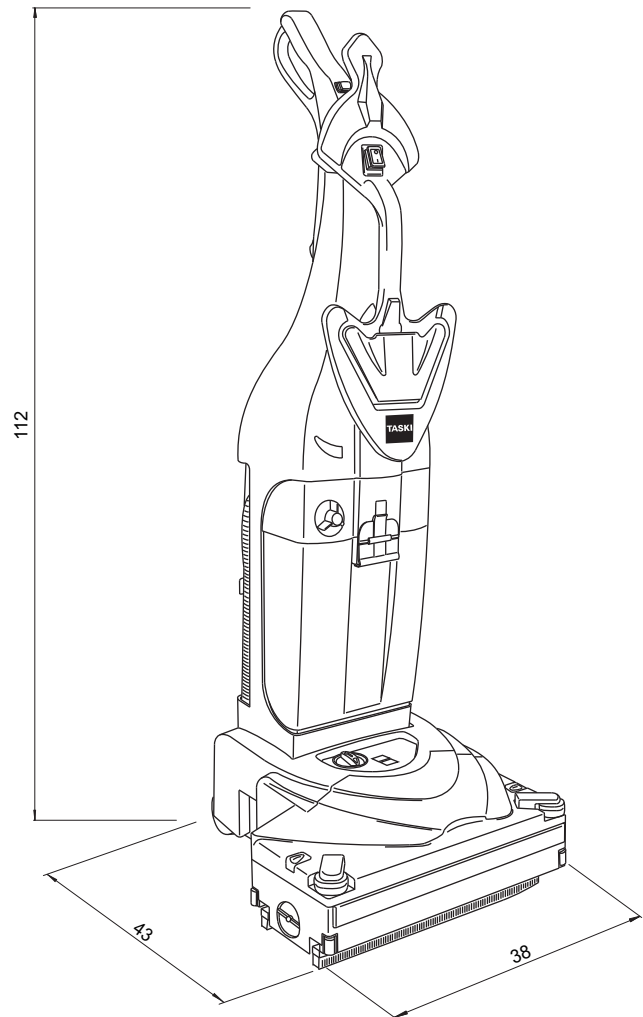

DE

Translation of the original instructions of use

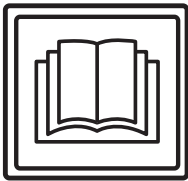

CAUTION!

Always read the instructions of use and the safety instructions before using the machine for the first time.

The instructions of use must be kept in a safe and well accessible place so that you can refer to them at any time.

Legend:



Caution:

This sign designates important information. Failure to follow these instructions may result in danger to persons and/or extensive damage to property!



Attention:

This sign designates important information. Failure to follow these instructions may result in faults and damage to property!



Notice:

This sign designates important information regarding the efficient use of the product. Failure to follow these instructions may result in faults!

- It includes instructions for the work steps that you must carry out in order.

Content

Intended use	54
Safety instructions	54
Cleaning products	55
Further documents	55
Structural layout	56
Batteries	57
Machine positions	58
Prior to commissioning	59
Beginning work with the machine	60
End of operation	61
Service, maintenance and care	63
Malfunctions	64
Technical data	64
Accessories	65
Transport	65
Disposal	65
Machine dimensions	65

Intended use

The machine is intended for commercial use (e.g. in hotels, schools, hospitals, factories, shopping centers, offices, etc.). Subject to strict compliance with the instructions of use, these machines are used for the wet cleaning of hard flooring. These machines are exclusively designed for use in interior zones.



Attention:

The machine must not be used for polishing, oiling, the application of wax, carpet cleaning or dust removal. The wet cleaning of parquet and laminate flooring with this machine is at your own risk.



Caution:

Changes to the machine that have not been authorized by Diversey will lead to the expiry of safety marks and CE conformity. Using the machine for purposes other than the intended purpose can cause injuries to persons, and damage to the machine and the working environment. Such cases will usually result in the termination of any warranty and possible guarantee claims.

Safety instructions

Due to their design and construction, TASKI machines comply with the relevant essential health and safety requirements of the EC directives; they therefore have the CE sign.



Caution:

The machine may only be used by persons who are adequately trained for the use of the machine or who have provided proof of their skills regarding the use of the machine and who are explicitly commissioned to use the machine.



Caution:

The machine must not be used by people with reduced physical, sensory or mental capacities, including children or people who lack experience or knowledge.

Children must be supervised to ensure that they do not play with the machine.



Caution:

Do not use the machine in rooms where explosive or highly combustible substances (e.g. gas, solvents, heating fuel, dust, etc.) are stored or processed.

These substances could be ignited by the electrical or mechanical components of the machine.



Caution:

Do not use the machine for the vacuum cleaning of poisonous, harmful, caustic or irritating substances (e.g. dangerous dust, etc.). The filter system does not adequately filter out these kinds of substances.

Possible impacts on the health of the user or third persons cannot be ruled out.



Caution:

Pay attention to the local situation as well as to third persons and children! In the vicinity of blind spots such as doors or curves in particular, it is important to reduce speed.



Caution:

Do not transport other persons and objects with this machine.

**Caution:**

In case of malfunction or defect or after collisions or toppling over, the machine must be inspected by an authorized expert before restarting. The same applies if the machine was left outdoors, immersed in water or subjected to moisture.

**Caution:**

The machine must be stopped immediately in case of damage to safety relevant parts such as brush covers, power supply cords or covers that enable access to live parts.

**Caution:**

The machine must not be stopped, parked or stored on slopes.

**Caution:**

The machine must be switched off for any work carried out on the machine.

**Caution:**

Do not use the machine in rooms with high electromagnetic interference (electric smog).

**Attention:**

The machine must be protected against unauthorized use. Therefore, keep the machine in a locked room before leaving it.

**Attention:**

Operate and keep the machine in a dry and low-dust environment at temperatures between +10°C / + 50 °F and +35°C/ + 95 °F degrees only.

**Attention:**

Only authorized experts who are familiar with all safety instructions relevant for this machine are allowed to repair mechanical or electrical machine parts.

**Attention:**

Only tools (brushes, pads or similar) that are specified in these instructions of use under accessories, or which have been recommended by a TASKI consultant, may be used. Any other brushes might impair the safety and functions of the machine.

**Attention:**

National regulations for personal protection and accident prevention as well as the manufacturer's instructions for the use of cleaning solutions must be consistently observed.

**Attention:**

In case of foam or liquid leakage from the machine, the suction unit must be switched off immediately.

**Attention:**

Use this machine with suitable batteries and approved chargers only.

**Attention:**

TASKI machines and devices are designed such that health risks caused by noise emissions or vibrations can be ruled out according to the current state of science.

See the technical data on page 64.

Cleaning products**Notice:**

TASKI machines are designed in such a way that optimal cleaning results can be achieved if TASKI cleaning products are used.

Other cleaning products may cause malfunctions and damage to the machine or the environment.

Therefore, we recommend the exclusive use of TASKI cleaning products.

Faults caused by inappropriate cleaning products are not covered by the guarantee.

For further details, please contact your TASKI service partner.

Further documents**Notice:**

The electric diagram of this machine is provided in the spare parts list.

Please contact your customer service for further information.

**Notice:**

These instructions of use as well as all instructions of use for TASKI machines are available on the following website:

www.taski.com/instructions-use

Structural layout

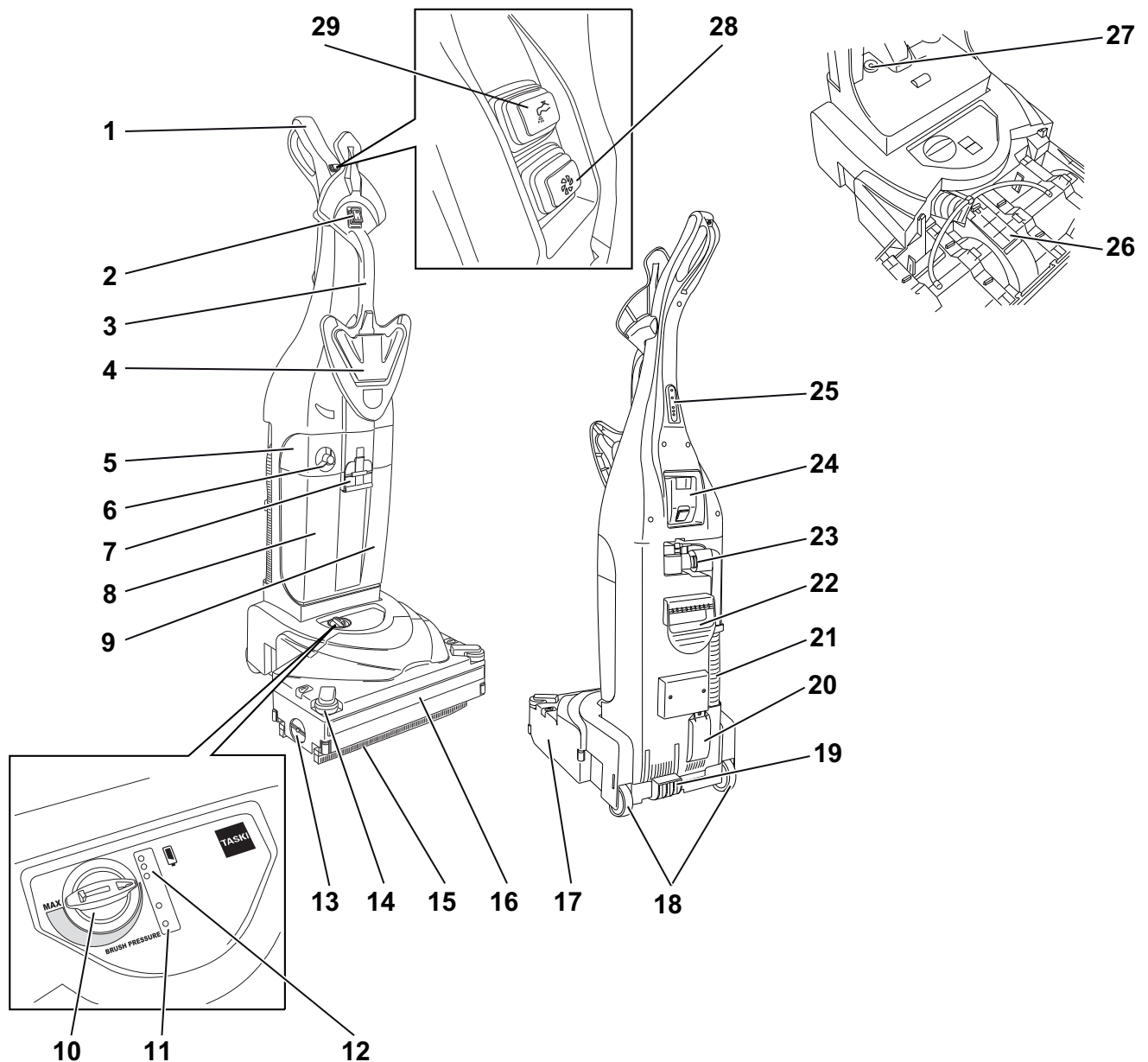

- | | | | |
|----|--|----|--|
| 1 | Handle | 25 | Turbine indicator (ON/OFF) |
| 2 | Main switch (ON/OFF) | 26 | Suction channel maintenance cover |
| 3 | Transport handle, front | 27 | Sponge filter |
| 4 | Tank lid unlocking | 28 | Suction unit motor switch (ON/OFF) |
| 5 | Filter housing | 29 | Cleaning solution supply switch (ON/OFF) (illuminated) |
| 6 | Dosing lid | | |
| 7 | Tank lock | | |
| 8 | Fresh water tank | | |
| 9 | Recovery tank | | |
| 10 | Brush pressure regulation | | |
| 11 | Brush pressure indicator | | |
| 12 | Battery indicator | | |
| 13 | Unlocking device for brush housing cover | | |
| 14 | Side bumper | | |
| 15 | Suction nozzle | | |
| 16 | Front bumper | | |
| 17 | Squeegee body | | |
| 18 | Transport wheels | | |
| 19 | Foot pedal | | |
| 20 | Solenoid valve | | |
| 21 | Suction hose | | |
| 22 | Transport handle, rear | | |
| 23 | Hose connection | | |
| 24 | Removable lithium-ion battery | | |

Batteries

Permissible batteries

Lithium-ion batteries are required for the use of this machine. Only these batteries guarantee a long service life.



Attention:

Only insert lithium-ion batteries recommended by the manufacturer.
Using other batteries may result in injuries or a fire hazard.

Safety measures to be taken when handling the batteries



Attention:

Observe the special guidelines for transportation, storage and use of lithium-ion batteries.



Attention:

The operating instructions provided by the battery manufacturer must also be observed.



Attention:

The product-safety-data-sheet provided by the battery manufacturer must also be observed.



Attention:

The supply terminals are not to be short-circuited.



Attention:

Keep the lithium-ion batteries away from fire and high temperatures.
Danger of explosion.



Attention:

The lithium-ion batteries must not be dismantled, crushed or burned.
There is otherwise danger of fire, explosion and acid burns.



Attention:

Damaged lithium-ion batteries (e.g. batteries with cracks, dropped or broken parts, bent, knocked and/or extracted contacts) must neither be charged nor further used.



Attention:

Do not use the lithium-ion batteries as an energy source for other, non-specified users.



Attention:

If the lithium-ion battery is too hot to touch, it could be defective. Place the machine in an incombustible place with sufficient ventilation and far from combustible materials, where it can cool down under observation.
Contact TASKI Service Partner after the lithium-ion battery has cooled down.



Attention:

Keep batteries clean and dry.

Charging process



Attention:

Recharge the lithium-ion batteries only in chargers given by the manufacturer.
Fire hazard in case of improper use.



Attention:

Make sure that the contacts of the lithium-ion battery and the contacts on the machine are free from foreign bodies before inserting the lithium-ion battery.



Attention:

Before decommissioning the machine for a longer period, the batteries must undergo a complete charging cycle.

Charging procedure with external battery charger

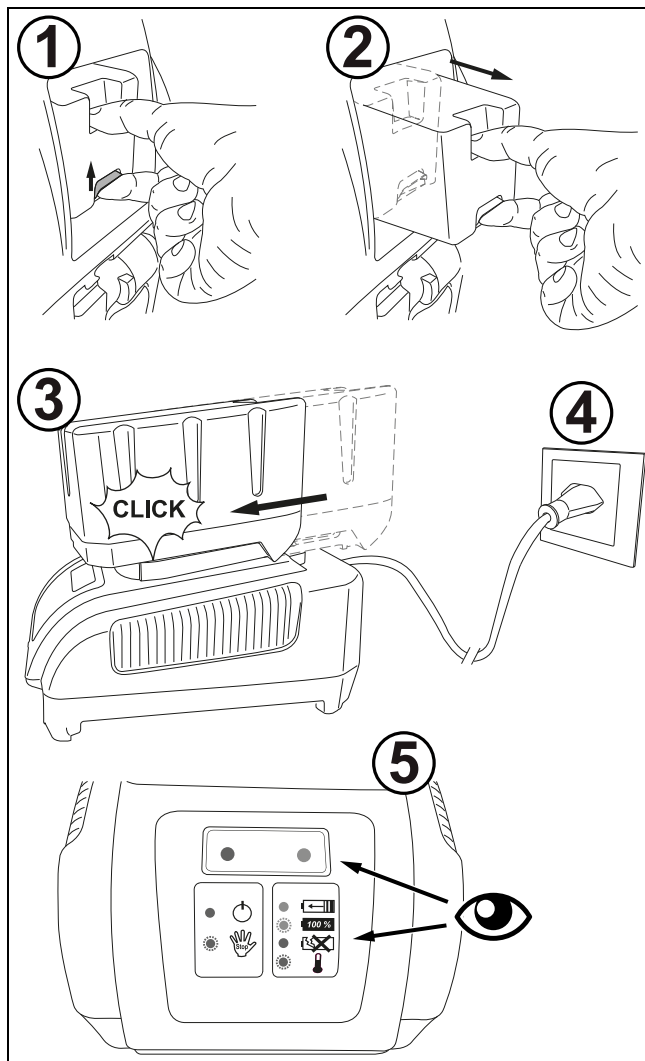

After charging

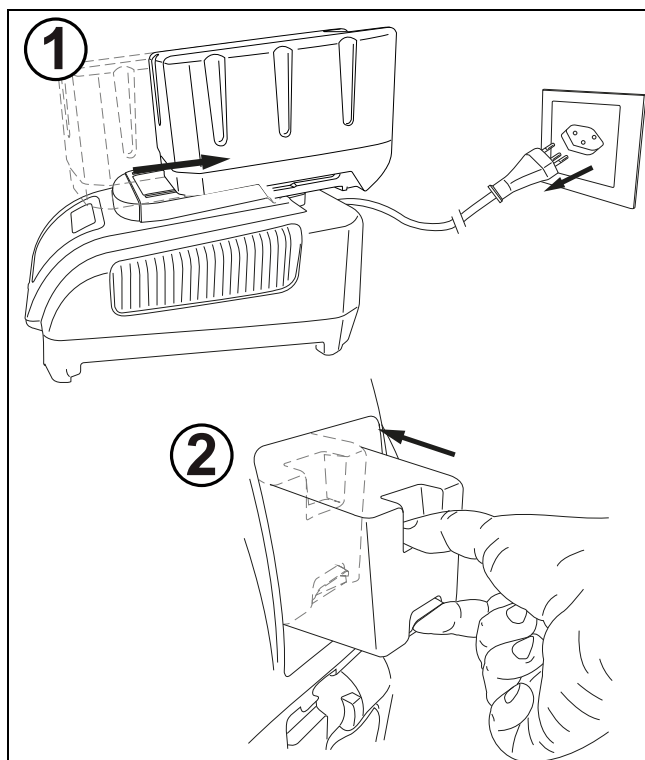

Maintenance and care of batteries

Notice:
 The maintenance and care of the lithium-ion batteries is limited to the compliance with the operating instructions of the battery manufacturer and with the handling described in these instructions of use.

Machine positions

Working position

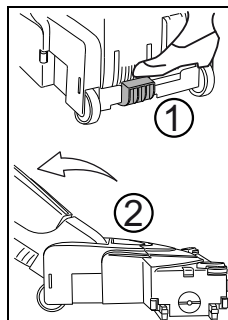

- Hold the machine firmly by the handle and bring it into the working position (2) by pressing the red foot pedal (1).
The electrical brushes switch on.

Standby position

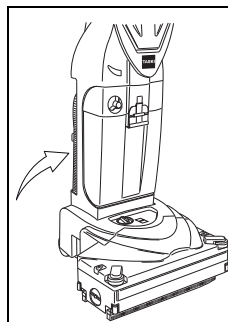

- Bring the machine to a vertical position.
The suction unit continues to operate.

Parking and transport position

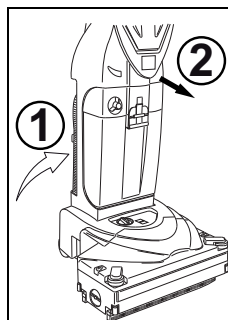

- Bring the machine to a vertical position (1).
- Carefully push the body of the machine forward (2).
This closes the solenoid valve and prevents water from leaking out.

Prior to commissioning

Filling the fresh water tank



Attention:

Max. permissible water temperature 35 °C/95 °F.

Diversey recommends using cold water since hot water will adjust to the floor temperature as soon as it is in contact with the floor. Thus there are no advantages to using hot water.

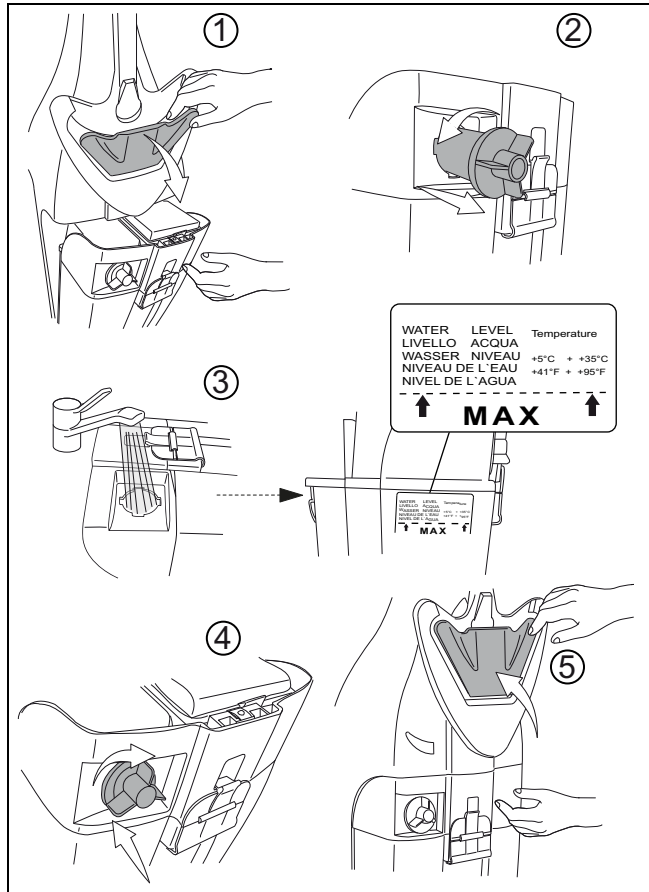

Notice:



The marking will be shown by a label on the side of the solution tank.

Dosing



Attention:

Wear gloves, goggles and appropriate (protective) working clothes when handling chemical products!



Notice:

Use chemical products recommended by Diversey only and always observe the product information.



Caution:

Using unsuitable products (e.g. products containing chlorine, acids or solvents) may cause harm to health and severe damage to the machine.



Attention:

Do not use any foaming products. Note the sticker on the front side of the tank.

Dosing examples:

Information on the pack- age of the product	Tank capaci- ty	Product volume per tank filling
1%	MAX	1 x MAX

EN

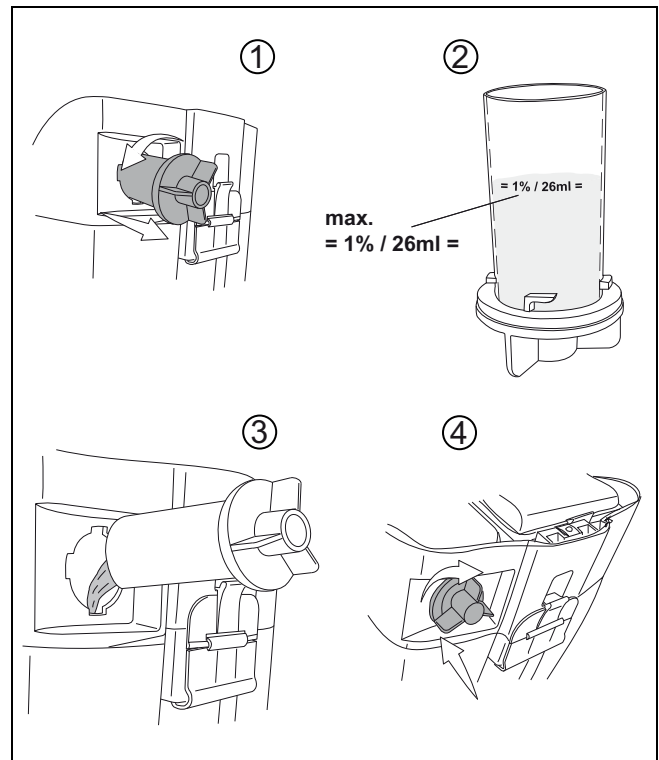

Pre-cleaning



Attention:

Remove any objects (wooden, metal parts etc.) from the cleaning surface.

The objects could be catapulted by the rotating tool, and thereby cause injuries to people and damage to the environment.

Beginning work with the machine



Attention:

Always wear slip-resistant shoes and appropriate working clothes when working with this machine!



Attention:

Start familiarization with the machine by making your first driving attempts in a free area.

Cleaning start

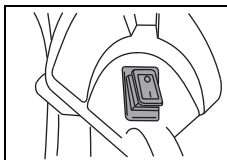

- Switch on the machine (main switch).

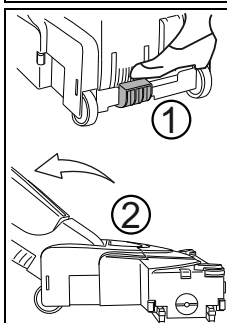

- Hold the machine firmly by the handle and bring it into the working position (2) by pressing the red foot pedal (1).

The electrical brushes switch on.

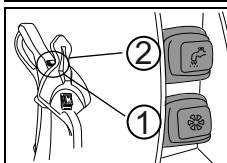

- Press the suction switch (1) to switch on the suction unit. (no lamp).
- Press the cleaning solution switch (2) to open the solenoid valve.

Switch lights up

Setting the brush pressure



Attention:

If the red brush pressure control lamp lights up, correct the brush height as described below.

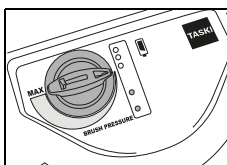

- Adjust the brush height (brush pressure) by turning the regulator until the green display lights up.

Cleaning method

Direct working method:

Scrubbing and suction in one work step.

Indirect working method:

Applying the cleaning solution, scrubbing and suction in several work steps.



Notice:

More precise details regarding the direct and indirect working method can be found on the respective method sheet.

Please contact your TASKI customer consultant for further details.

Replenishing cleaning solution



Attention:

The flooring may be damaged when working without cleaning solution.

- The machine must be switched off.
- Open the tank lid.
- Fill the fresh water tank with water, see page 59.
- Add the cleaning product using the dosing cup.
- Close the tank lid.

LED display	Status indicator
Display green	Brush height (brush pressure) correctly set.
Display red	Correct the brush height (brush pressure). Turn the setting knob to the right for more, and to the left for less brush pressure.

End of operation

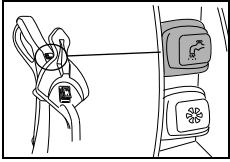

- Press the switch cleaning solution.
The cleaning solution supply is stopped.

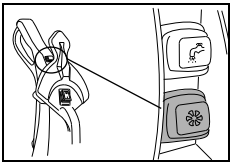

- Allow the suction unit to run further so that the remaining water in the hose will be sucked out.
- Switch off the suction unit.
The suction motor is switched off.

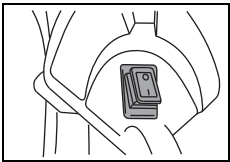

- Switch off the machine (main switch).

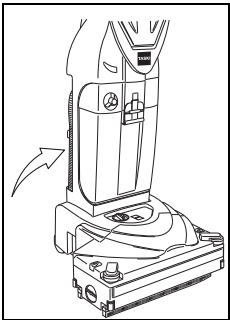

- Bring the machine to a parking and transport position.



Attention:

The machine must now be emptied and cleaned. Switch off the machine (main switch) and remove the plug from the mains socket.

Removing and cleaning the squeegee

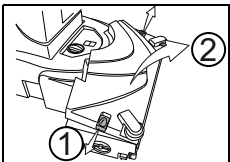

- Open the cover of the brush housing by loosening the side latches.

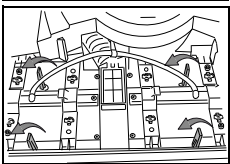

- Turn the four yellow clips to the left to loosen the squeegees.

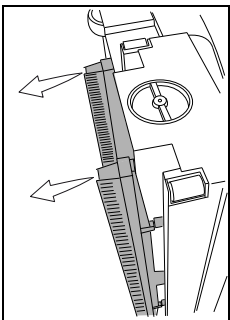

- Turn the machine onto the side to remove the squeegees.

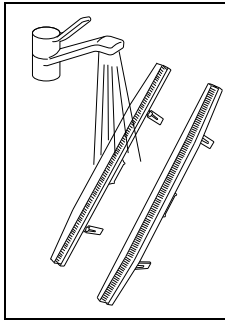

- Wash out the squeegees under running water.

Notice:



Check the condition of the suction lips before the installation.

Bristles that are too short or damaged suction lips will impair the cleaning result!

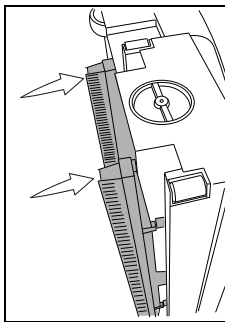

- Reinstall the squeegees into the squeegee body.

In doing this, note that the front and rear squeegees are different. The position is shown on the upper side of the squeegees. (FRONT + REAR)

Empty and clean the recovery tank and fresh water tank

Notice:



Drain water or cleaning solution must be disposed of in compliance with the national regulations.

Notice:



When draining the recovery tank, the regulations of the detergent supplier regarding personal protective equipment must be observed.

Emptying the recovery tank and fresh water tank

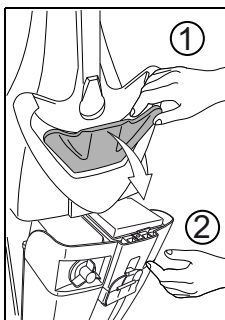

- Remove the tank by pulling on the tank unlocking device (1).
- Hold the tank (2) with the other hand so that it does not fall out of the holder when unlocked.
- Pull the solution tank out of the holder.

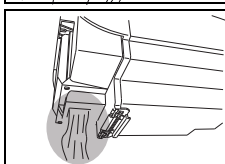

- Empty the dirty water from the tank through the opening provided at the rear.

Cleaning the recovery tank and fresh water tank

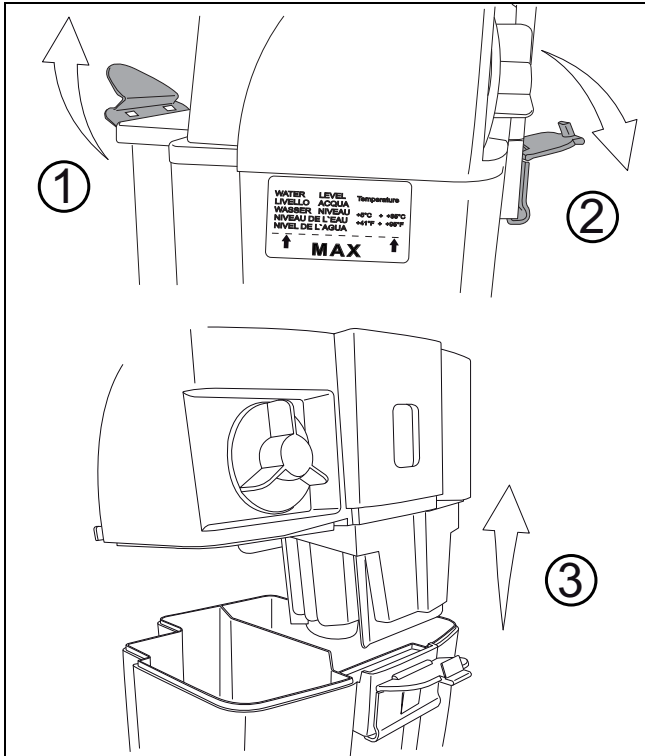

- Rinse the recovery tank and the fresh water tank thoroughly with clean water.

Wash out the motor protection filter

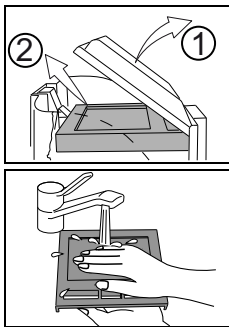

- Remove the motor protection filter from the transparent filter protection above the filter housing.
- Wash out the motor protection filter under running water.
- After washing it out, squeeze the motor protection filter so that the water can flow out.



Attention:

Do not reinsert the motor protection filter before it is completely dry.

Washing out the filter housing and the float

- Remove the motor protection filter from the filter protection before you wash out the filter housing.

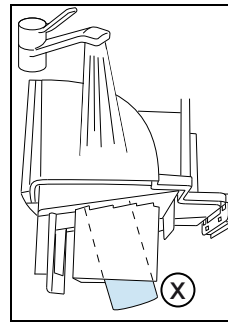

- Wash out the filter housing and the float (X), which is located on the underside of the filter housing, under running water.

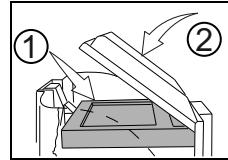

- Reinsert the dry motor protection filter.

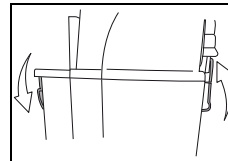

- Place the filter housing on the tank and lock it into place.

Cleaning / Replacing the brush roller

Replacing the brush roller



Attention:

Danger of injury due to sharp objects.
Wear gloves for your own protection!



Notice:

Check the brush roller for wear after every use.

Bristles that are too short or a damaged brush roller could lead to damage to the floor and impair the cleaning result!

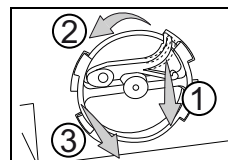

- Place the machine on its side so that the brush holders on the side are pointing upwards.
- Press the rotation lock (1) and turn the brush holder (2) counterclockwise and pull it out of the housing (3) in order to remove it.

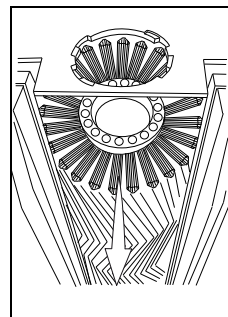

- Take out the brush roller.
- Clean the brush roller under running water.

Cleaning the brush housing

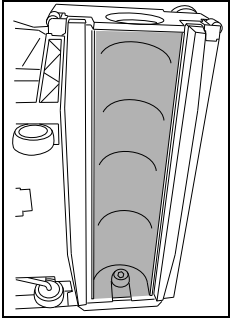

- Clean the brush housing with a damp cloth.

Installing/Replacing the brush roller

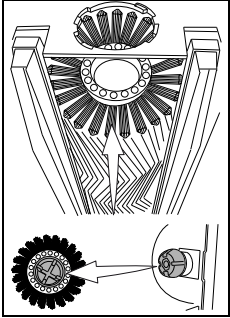

- Reinstall the brush roller.
In order to reinstall the brush roller, you must set the white traveler of the roller into the white traveler in the nozzle head. The ribs of the traveler on the brush roller must be set into the correct cutouts on the traveler of the squeegee body.

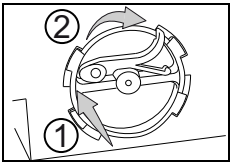

- Reinsert the brush holder and turn it clockwise until the rotation lock engages.

Cleaning the transport wheels

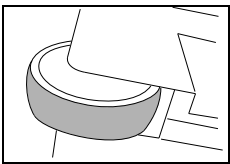

- Before and after every use of the machine, clean the running surfaces of the transport wheels with a damp cloth.
The transport wheels can become soiled by transport over the asphalt.

Cleaning the machine



Attention:

Never clean the machine with a high-pressure cleaner or water jet.
Water ingress in the machine may cause considerable damage to the mechanical or electrical parts.

- Wipe the machine with a moist cloth.

Storing / parking the machine (not in operation)



Notice:

The machine must be switched off.



Notice:

Store the machine with the tool lifted. Thus, the tank can dry, and the generation of mold and unpleasant odors is prevented.

Service, maintenance and care

The maintenance of the machine is a prerequisite for impeccable operation and a long service life.



Attention:

Use original TASKI parts only; otherwise, any warranty and liability claims will expire.

Activity	◇	◇◇	◇◇◇	Page
Wash out the squeegees	X			61
Clean the brush roller	X			62
Periodically check the length of the bristles		X		
Replacing the brush roller			X	62
Suction channel maintenance cover	X			61
Clean/replace the motor protection filter		X		62
Clean the machine with a moist cloth	X			
Cleaning the transport wheels		X		63

Service intervals

TASKI machines are high-quality machines that have been checked for safety in the factory and by authorized inspectors. Electrical and mechanical parts are subject to wear and aging after a longer period of use.

- In order to maintain operational safety and readiness for use, the machine must be serviced after 500 working hours or at least once a year.



Notice:

In case of extraordinary use and/or insufficient maintenance, shorter intervals are required.

Service center

Please always indicate the type and number of the machine whenever you contact us for order placing or in case of malfunctions.

The required data are provided on the nameplate of your machine. The address of your closest TASKI service partner is provided on the last page of these instructions of use.

Malfunctions

Malfunction	Possible causes	Troubleshooting	Page
Machine without function	Main switch is switched off	• Switch on the main switch	56
	Low battery	• Charge battery	58
	Defective battery	• Contact your service partner	
	Motor does not turn	• Contact your service partner	
	Main switch defect	• Contact your service partner	
Brush roller does not turn	Machine not in the working position	• Bring the machine into the working position	60
	Motor turns, brush does not	• Drive defective • Contact your service partner	
Poor suction performance	Motor protection filter soiled	• Clean or replace motor protection filter	62
	Suction hose not connected	• Check the suction hose and connect it correctly, if required	

Technical data

Machine		
Working width	34	cm
Suction nozzle width	36	cm
Dimensions (LxWxH)	43 x 38 x 112	cm
Maximum weight of operational machine	13	kg
Rated voltage	36 V	DC
Rated power, nominal	520	W
Fresh water tank, nominal +/- 5%	2.6	l

Values according to IEC 60335-2-72		
Sound pressure level LpA	74	dB(A)
Uncertainty KpA	3	dB(A)
Vibration	<2.5	m/s ²
Uncertainty K	0.25	m/s ²
Splash water guard	IPX4	
Protection class	III	

Accessories

No.	Item
7516236	Brush roller medium black
7516237	Brush roller hard red
7516546	Squeegee set
7519049	Pad roll
7524166	TASKI Li-Ion battery 36 V / 6 Ah
7524167	Battery charger 100-120 V 60 Hz
7524168	Battery charger 220-240 V 50/60 Hz
7524169	Battery charger 220-240 V 50/60 Hz (without any main cords)

Transport



Notice:

Transport the machine in upright position.



Notice:

Make sure that the machine is lashed and secured in the transport vehicle.



Notice:

Remove the lithium-ion batteries when storing and transporting the machine.

Disposal



Notice:

After withdrawal from service, the machine and accessory parts must be adequately disposed of in compliance with the national regulations. Please contact your Diversy service partner for help.

Batteries



Attention:

Remove all batteries from the machine prior to disposal.

Used batteries must be disposed of in an environmentally friendly way in compliance with the EC directive 2006/66/EC or the respective national regulations.

Machine dimensions

The dimensions are in centimeters!

