

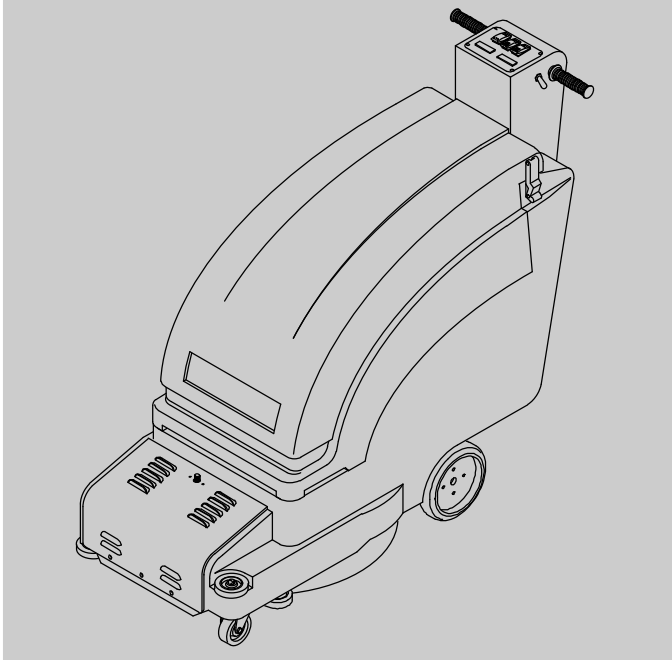

# 2510/2550

36 Volt Dust Control Burnisher

## Parts Manual

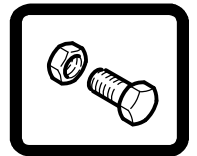

Model Part No.:  
9003531 - 2510  
9003532 - 2510 Complete  
9006168 - 2510 w/AGM Complete  
9006149 - 2510 China Model  
9003535 - 2550  
9003536 - 2550 Complete  
9006170 - 2550 w/AGM Complete  
609180 - 2550 Japan Model

**North America / International**

[www.tennantco.com](http://www.tennantco.com)

9005432  
Rev. 01 (02-2011)



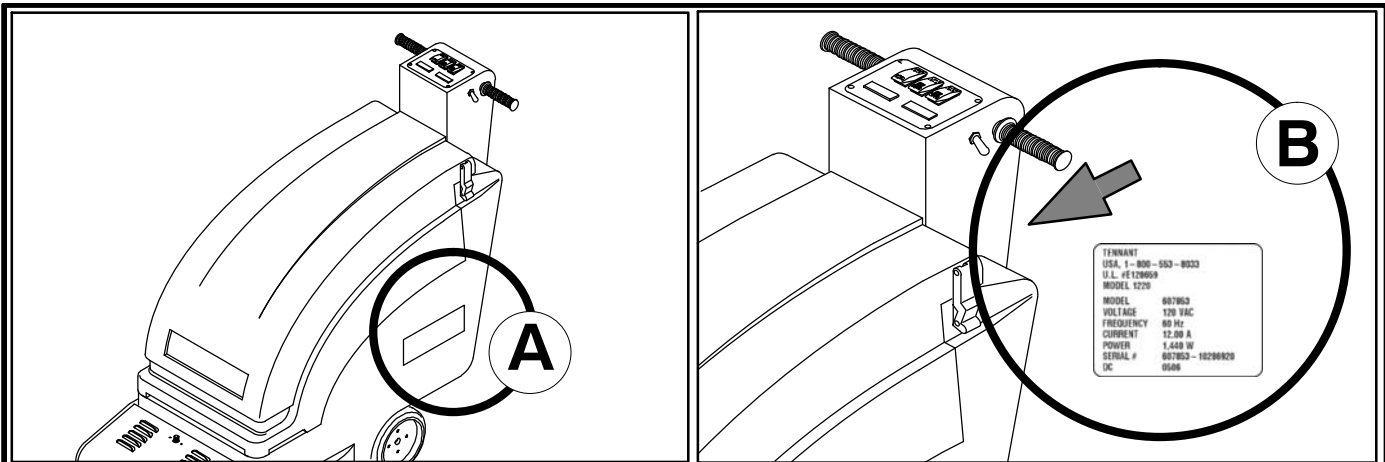

Ref	Part No.	Serial Number	Description	Qty.
1	82681	(000000—)	Bracket Wldt, Lpg Mount	1
2	63810	(000000—)	Ch Assy, Lpg Tank Mtg, W/Nut	4
3	51839	(000000—)	at Adjustable, Lpg Tank Mtg	2
4	49263	(000000—)	Tie, Cable	3
5	82556	(000000—001039)	Bracket, Vaporizer	1
6	54930	(000000—)	Vaporizer, LPG	1

#### HOW TO ORDER PARTS – See diagram above

Only use TENNANT Company supplied or equivalent parts. Parts and supplies may be ordered online, by phone, by fax or by mail.

Follow the steps below to ensure prompt delivery.

1. (A) Identify the machine model.
2. (B) Identify the machine serial number from the data label.
3. (C) Ensure the proper serial number is used from the parts list.
4. Identify the part number and quantity.  
Do not order by page or reference numbers.
5. Provide your name, company name, customer ID number, billing and shipping address, phone number and purchase order number.
6. Provide detail shipping instructions.

- (D) ▽ – identifies an assembly  
 ▲ – identifies parts included in assembly  
 (E) ● – identifies a recommended stock item

#### Please fill out at time of installation for future reference.

Model No. – \_\_\_\_\_  
 Serial No. – \_\_\_\_\_  
 Machine Options – \_\_\_\_\_  
 Sales Rep. – \_\_\_\_\_  
 Sales Rep. phone no. – \_\_\_\_\_  
 Customer ID Number – \_\_\_\_\_  
 Installation Date – \_\_\_\_\_

**Tennant Company**  
 PO Box 1452  
 Minneapolis, MN 55440 USA  
 Phone: (800) 553-8033 or  
 (763) 513-2850  
 www.tennantco.com

**Tennant Company Shanghai**  
 Building 3, No. 66, Tian Ying Road  
 Shanghai Qingpu Industrial Zone  
 Shanghai 201700  
 People's Republic of China  
 Phone: (86-21) 6922-5333  
 www.tennantco.com.cn

**TENNANT Company Japan**  
 Sanka Bldg. 5F  
 2-9 Minami Saiwai-cho  
 Saiwai-Ku  
 Kawasaki, Kanagawa 212-0016  
 Tel: 044-556-1201  
 Fax: 044-556-1202  
 www.tennant.co.jp

Specifications and parts are subject to change without notice.

Copyright © 2008-2011  
 TENNANT Company, Printed in USA.

<b>ES</b>	<p><b>CÓMO SOLICITAR PIEZAS - Consulte el diagrama anterior.</b></p> <p>Utilice sólo las piezas suministradas por TENNANT Company o piezas equivalentes. Puede solicitar las piezas a través de internet, por teléfono, por fax o por correo.</p> <p>Siga los siguientes pasos para que la entrega sea rápida.</p> <ol style="list-style-type: none"> <li>1. <b>(A)</b> Indique el modelo de máquina.</li> <li>2. <b>(B)</b> Indique el número de serie de la etiqueta de datos.</li> <li>3. <b>(C)</b> Asegúrese de que indica el número de serie correcto de la lista de piezas.</li> <li>4. Indique la cantidad y el número de la pieza. No realice el pedido indicando el número de página o el de referencia.</li> <li>5. Incluya su nombre, el nombre de la empresa, el ID de cliente, las direcciones de envío y facturación, el número de teléfono y el número del pedido de compra.</li> <li>6. Facilite instrucciones de envío.</li> </ol> <hr/> <p><b>(D)</b> ▽ - identifica un conjunto ▲ - identifica piezas de un conjunto <b>(E)</b> ● - identifica un artículo que conviene tener en stock</p>	<p><b>Rellene estos datos cuando realice la instalación para utilizarlos como referencia en el futuro.</b></p> <p>Nº modelo - _____</p> <p>Nº serie - _____</p> <p>Opciones de la máquina - _____</p> <p>Vendedor - _____</p> <p>Nº teléfono vendedor - _____</p> <p>Nº cliente - _____</p> <p>Fecha de instalación - _____</p>
-----------	----------------------------------------------------------------------------------------------------------------------------------------------------------------------------------------------------------------------------------------------------------------------------------------------------------------------------------------------------------------------------------------------------------------------------------------------------------------------------------------------------------------------------------------------------------------------------------------------------------------------------------------------------------------------------------------------------------------------------------------------------------------------------------------------------------------------------------------------------------------------------------------------------------------------------------------------------------------------------------------------------------------------------------------------------------------------------------------------------------------------------	---------------------------------------------------------------------------------------------------------------------------------------------------------------------------------------------------------------------------------------------------------------------------------------------------------------------------------

<b>FR</b>	<p><b>COMMENT COMMANDER DES PIÈCES DÉTACHÉES - Voir le schéma ci-dessus.</b></p> <p>Utilisez uniquement des pièces fournies par la société TENNANT ou équivalentes. Les pièces et fournitures peuvent être commandées en ligne, par téléphone, fax, ou par courrier.</p> <p>Suivez les étapes ci-dessous pour assurer une livraison rapide.</p> <ol style="list-style-type: none"> <li>1. <b>(A)</b> Identifiez le modèle de la machine.</li> <li>2. <b>(B)</b> Identifiez le numéro de série de la machine, à partir de l'étiquette signalétique.</li> <li>3. <b>(C)</b> Assurez-vous que le numéro de série correct est utilisé à partir de la liste de pièces détachées.</li> <li>4. Identifiez le numéro de pièce et la quantité. Ne commandez pas par page ou numéros de référence.</li> <li>5. Fournissez votre nom, le nom de votre société, votre numéro d'identification de client, l'adresse de facturation et d'expédition, le numéro de téléphone et le numéro du bon de commande.</li> <li>6. Fournissez des instructions d'expédition détaillées.</li> </ol> <hr/> <p><b>(D)</b> ▽ - identifie un assemblage ▲ - identifie les pièces composant l'assemblage <b>(E)</b> ● - identifie un article de stock recommandé</p>	<p><b>A remplir au moment de l'installation à titre de référence.</b></p> <p>Nº du modèle - _____</p> <p>Nº de série - _____</p> <p>Options de la machine - _____</p> <p>Agent commercial - _____</p> <p>Nº tél. de l'agent commercial - _____</p> <p>Numéro d'identification client - _____</p> <p>Date d'installation - _____</p>
-----------	------------------------------------------------------------------------------------------------------------------------------------------------------------------------------------------------------------------------------------------------------------------------------------------------------------------------------------------------------------------------------------------------------------------------------------------------------------------------------------------------------------------------------------------------------------------------------------------------------------------------------------------------------------------------------------------------------------------------------------------------------------------------------------------------------------------------------------------------------------------------------------------------------------------------------------------------------------------------------------------------------------------------------------------------------------------------------------------------------------------------------------------------------------------------------------------------------------------------------------------------	-------------------------------------------------------------------------------------------------------------------------------------------------------------------------------------------------------------------------------------------------------------------------------------------------------------------------------------

<b>CN</b>	<p><b>如何订购部件 - 参见下表</b></p> <p>仅使用 TENNANT 公司提供的或同等部件。部件和供应可以在线订购，通过电话、传真或邮件订购。</p> <p>请遵循下面的步骤确保及时交付。</p> <ol style="list-style-type: none"> <li>1. <b>(A)</b> 确定机器型号。</li> <li>2. <b>(B)</b> 从数据标签确定机器序列号。</li> <li>3. <b>(C)</b> 确保使用部件列表中的正确序列号。</li> <li>4. 确定部件号和数量。 不要按页面或参考编号订购。</li> <li>5. 提供您的姓名、公司名称、客户 ID 号、付帐和送货地址、电话号码和采购单编号。</li> <li>6. 提供详细的送货说明。</li> </ol> <hr/> <p><b>(D)</b> ▽ - 确定组件 ▲ - 确定组件中包含的组件 <b>(E)</b> ● - 确定建议的库存项</p>	<p><b>请在安装时填写供未来参考。</b></p> <p>型号 - _____</p> <p>序列号 - _____</p> <p>机器选项 - _____</p> <p>销售代表 - _____</p> <p>销售代表电话号码 - _____</p> <p>客户 ID 编号 - _____</p> <p>安装日期 - _____</p>
-----------	--------------------------------------------------------------------------------------------------------------------------------------------------------------------------------------------------------------------------------------------------------------------------------------------------------------------------------------------------------------------------------------------------------------------------------------------------------------------	------------------------------------------------------------------------------------------------------------------------------------------------------------------------------

<b>JP</b>	<p><b>パーツの発注方法 ? 上記の図を参照してください</b></p> <p>TENNANT社製のパーツまたは同等品のみをお使いください。パーツやサプライ品のご注文は、オンライン、電話、FAX、または手紙でお願いいたします。</p> <p>確実にお届けできるように、以下の情報お知らせください。</p> <ol style="list-style-type: none"> <li>1. <b>(A)</b> 製品のモデル名をお知らせください。</li> <li>2. <b>(B)</b> 製品のデータラベルに印刷されているシリアル番号をお知らせください。</li> <li>3. <b>(C)</b> パーツリストを参照して、シリアル番号が正しいかご確認ください。</li> <li>4. パーツ番号と数量をお知らせください。マニュアル/カタログのページ番号や参照番号でのご注文はご遠慮ください。</li> <li>5. お客様のお名前、会社名、顧客ID番号、請求/発送先住所、電話番号、注文書番号をお知らせください。</li> <li>6. 発送に関するご希望があれば、明記してください。</li> </ol> <hr/> <p><b>(D)</b> ▽ - アセンブリを示します ▲ - アセンブリに含まれるパーツを示します <b>(E)</b> ● - 当社推薦の在庫用品を示します</p>	<p><b>後日確認できるように、設置時に記入してください。</b></p> <p>モデルNo. - _____</p> <p>シリアルNo. - _____</p> <p>製品のオプション - _____</p> <p>販売代理店 - _____</p> <p>販売代理店の電話番号 - _____</p> <p>顧客ID番号 - _____</p> <p>設置日 - _____</p>
-----------	-------------------------------------------------------------------------------------------------------------------------------------------------------------------------------------------------------------------------------------------------------------------------------------------------------------------------------------------------------------------------------------------------------------------------------------------------------------------------------------------------------------------------------------------------------------------------------------------------------------------------------------	-----------------------------------------------------------------------------------------------------------------------------------------------------------------------------------------------------



**STANDARD PARTS**

MAIN HOUSING GROUP .....	6
MAIN HOUSING GROUP – CONT'D .....	8
PAD DRIVER GROUP .....	10
WHEEL GROUP, DRIVE (2550 MODEL) .....	12
WHEEL GROUP, PUSH (2510 MODEL) .....	14
CONTROL CONSOLE GROUP (2550 MODEL) .	16
CONTROL CONSOLE GROUP (2510 MODEL) .	18
ELECTRICAL GROUP .....	20
BATTERY GROUP, LEAD ACID 12V/225AH ....	22
BATTERY GROUP, AGM 12V/234AH .....	23
OFF-BOARD BATTERY CHARGER GROUP ...	24
ON-BOARD BATTERY CHARGER GROUP ....	25
WIRING DIAGRAM 2550 MODEL WITH ON-BOARD CHARGER .....	26
LADDER DIAGRAM 2550 MODEL WITH ON-BOARD CHARGER .....	27
WIRING DIAGRAM 2550 MODEL WITHOUT ON-BOARD CHARGER .....	28
LADDER DIAGRAM 2550 MODEL WITHOUT ON-BOARD CHARGER .....	29
WIRING DIAGRAM 2510 MODEL WITH ON-BOARD CHARGER .....	30
LADDER DIAGRAM 2510 MODEL WITH ON-BOARD CHARGER .....	31
WIRING DIAGRAM 2510 MODEL WITHOUT ON-BOARD CHARGER .....	32
LADDER DIAGRAM 2510 MODEL WITHOUT ON-BOARD CHARGER .....	33
WIRE HARNESS, MAIN, 2550 .....	34
WIRE HARNESS, MAIN, 2550 – CONT'D .....	35
WIRE HARNESS, MAIN, 2510 .....	36
WIRE HARNESS, MAIN, 2510 – CONT'D .....	37

**OPTIONS**

HOUR METER, EMERGENCY STOP AND KEYSWITCH KITS .....	38
LOW VOLT INTERRUPT KIT .....	39
PARKING BRAKE KIT .....	40
FLASHING LIGHT KIT .....	41
AIR INLET GROUP .....	42

MAIN HOUSING GROUP

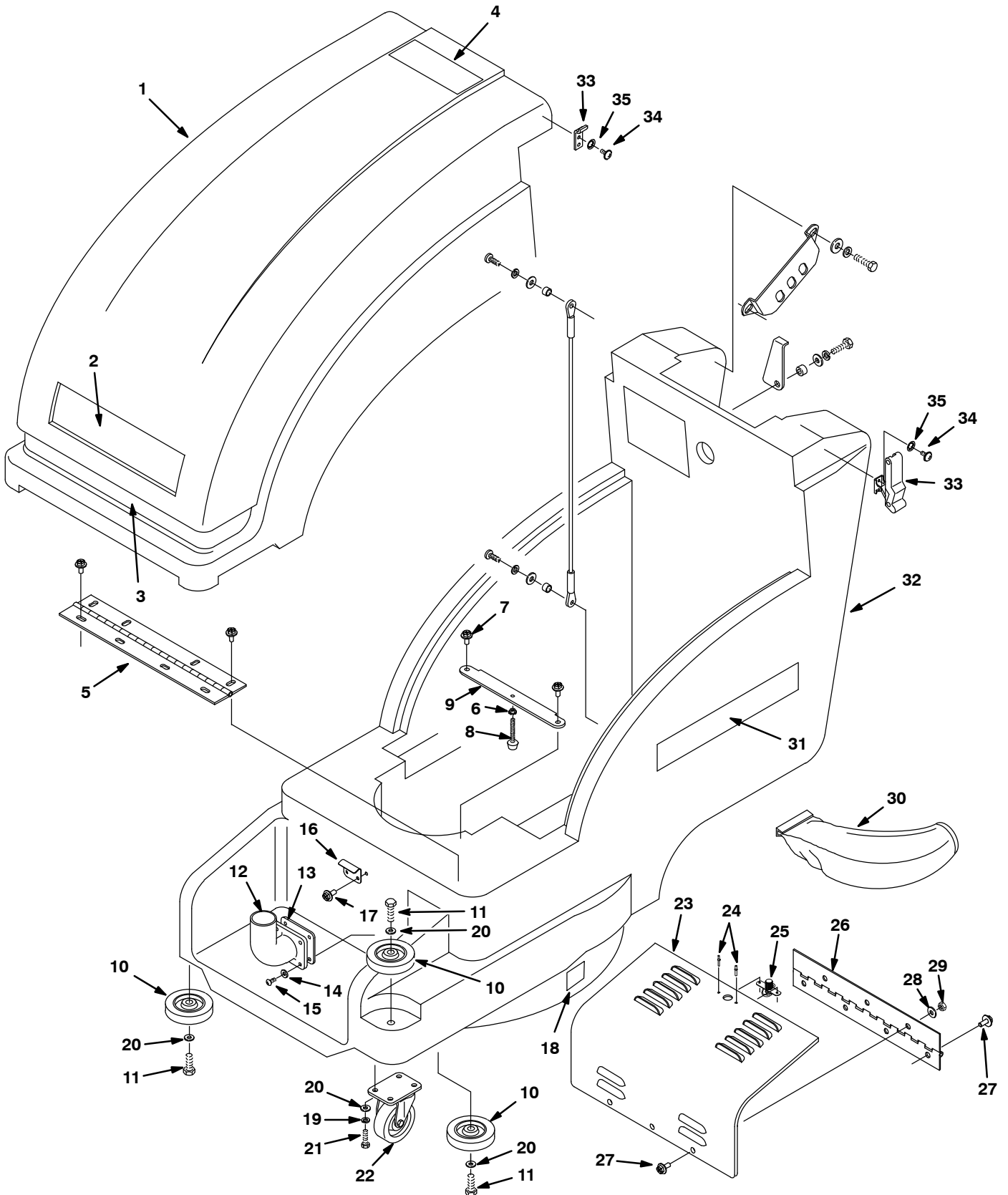

## MAIN HOUSING GROUP

Ref.	Part No.	Serial Number	Description	Qty.
▽	1	614230	(00000000- ) Cover Assy, Battery, W/ Label, TI	1
	1	607603	(00000000- ) Cover, RM-TL, (Japan & China Model)	1
▲	2	120192	(00000000- ) Label, Logo, 07.1l White /Clr [Tennant]	1
▲	3	604297	(00000000- ) Label [Recess]	1
▲	4	1026386	(00000000- ) Label, Warning [Expl,Fire,Shk En/Fr/Es]	1
	4	613862	(00000000- ) Label, Warning, 6 X 2 Tj[Dc Brn/Scr/Ext] (Japan Model)	1
	4	1037349	(00000000- ) Label, Warning [Exp,Fre,Shk En/Fr/Es/Ch] (China Model)	1
	5	603268	(00000000- ) Hinge, .25pin .07 2.5w 16.0l, PI	1
	6	140524	(00000000- ) Nut, Hex, Lock, .25-20, Kep	1
	7	1034731	(00000000- ) Screw, Hex, M6 X 1.00 X 16, Ss, Sems	2
	8	606684	(00000000- ) Stop, Motor	1
	9	604276	(00000000- ) Bracket, Stop, Motor	1
	10	1014918	(00000000- ) ● Wheel, 03.0d 0.88w 0.31b, W/ Bshg, Rbr	4
	11	74440	(00000000- ) Screw, Hex, M8 X 1.25 X 40, NI, Ss	4
	12	613136	(00000000- ) Deflector, Elbow, Rm-Nat [Magnatwin]	1
	13	100121	(00000000- ) Gasket, Elbow, .28, 03.50w 03.50l, Adh	1
	14	140011	(00000000- ) Washer, Flat, 0.21b 0.45d .03, Ss	4
	15	069760103	(00000000- ) Screw, Rnd, #10 X 1.00, Phl, PI [A]	4
	16	604295	(00000000- ) Plate, Latch	1
	17	1034731	(00000000- ) Screw, Hex, M6 X 1.00 X 16, Ss, Sems	2
	18	578769	(00000000- ) Label, Parts, Moving [Textless]	2
	19	140015	(00000000- ) Washer, Lock, Split, 0.31, Ss	4
	20	140027	(00000000- ) Washer, Flat, 0.35b 0.75d .04, Ss	8
	21	15675	(00000000- ) Screw, Hex, M8 X 1.25 X 16, Ss	4
	22	103001	(00000000- ) Caster, Swivel, 3.0d 1.3w, 4hole	1
	23	608575	(00000000- ) Cover, Bag, Dust, TI	1
	24	140706	(00000000- ) Rivet, Blind, .125d, PI	2
	25	140962	(00000000- ) Latch, Cmpr, Spring, Knurled Knob, PI	1
	26	603269	(00000000- ) Hinge, .12pin .06 2.0w 13.0l, Yel PI	1
	27	1034731	(00000000- ) Screw, Hex, M6 X 1.00 X 16, Ss, Sems	7
	28	140000	(00000000- ) Washer, Flat, 0.28b 0.62d .04, Ss	7
	29	08712	(00000000- ) Nut, Hex, Lock, M6 X 1.00, NI, Ss	3
	30	900210	(00000000- ) ● Filter, Bag, Cloth, Dust-Cntrl [Bur]	1
	30	611781	(00000000- ) ● Bag, Fltr, Paper [Spd Glm, 1pick=1pkg]	1
	31	608149	(00000000- ) Label [Tennant 2550]	2
	31	608150	(00000000- ) Label, Model [2510]	2
	32	607600	(00000000- ) Frame, Chassis, Rm-TI, Trimmed [2510/50]	1
	33	49800	(00000000- ) ● Latch	2
	34	200070340	(00000000- ) Screw, Pan, Phl, M4 X 0.70 X 8, PI	8
	35	02938	(00000000- ) Washer, Lock, Int, 08, Ss	8

▽ ASSEMBLY

▲ INCLUDED IN ASSEMBLY

● RECOMMENDED STOCK ITEMS

MAIN HOUSING GROUP - CONT'D

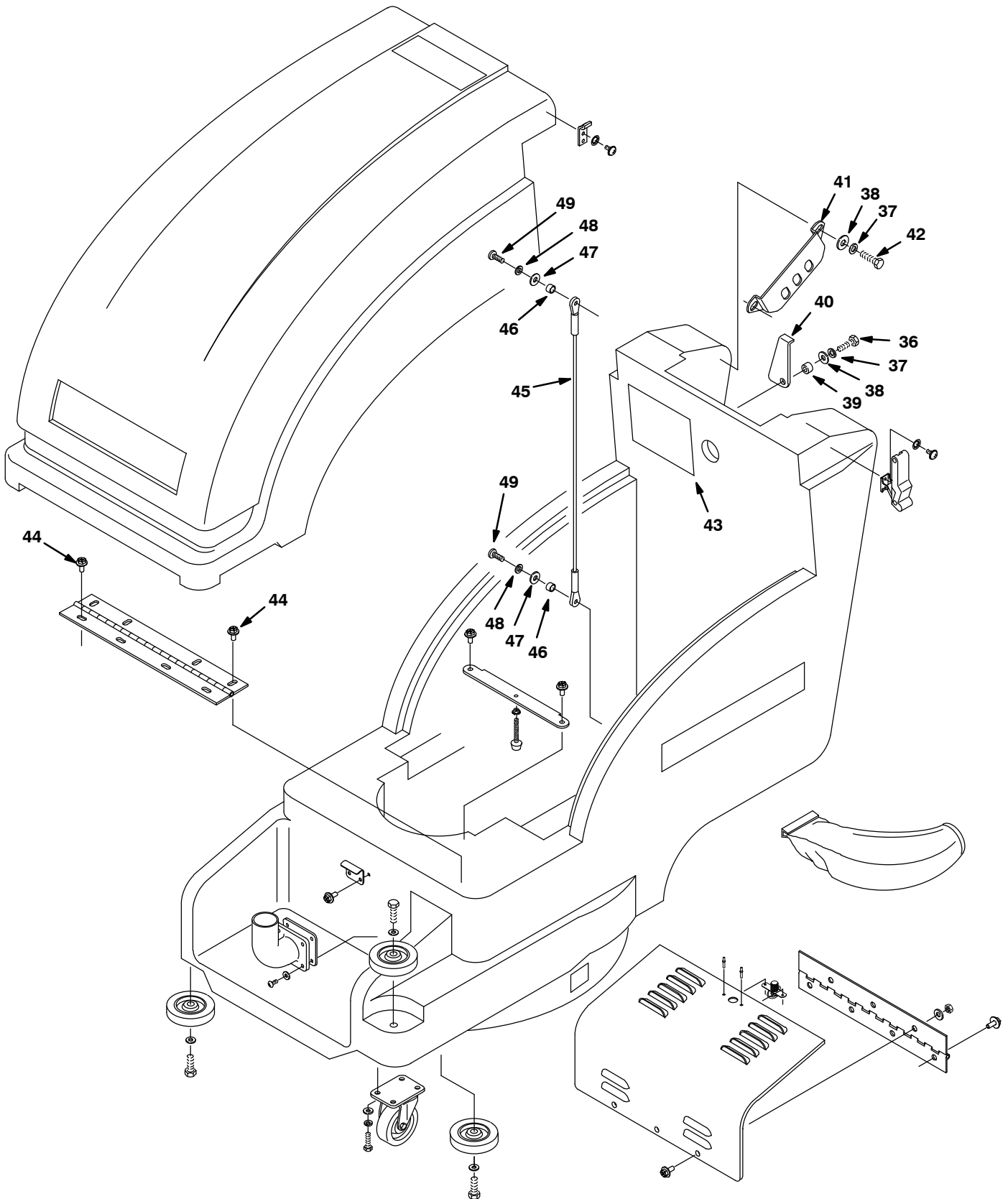



## MAIN HOUSING GROUP – CONT'D

Ref.	Part No.	Serial Number	Description	Qty.
36	15675	(00000000–	) Screw, Hex, M8 X 1.25 X 16, Ss	1
37	140015	(00000000–	) Washer, Lock, Split, 0.31, Ss	5
38	140027	(00000000–	) Washer, Flat, 0.35b 0.75d .04, Ss	5
39	611418	(00000000–	) Sleeve, P/M, 0.31b 0.44d 0.1l, Pl	1
40	604637	(00000000–	) Support, Cover	1
41	230661	(00000000–	) Plate, Hsng, Lock Cntrl	2
42	15675	(00000000–	) Screw, Hex, M8 X 1.25 X 16, Ss	4
43	604304	(00000000–	) Label, Hzrd, Battery Connections	1
44	1034731	(00000000–	) Screw, Hex, M6 X 1.00 X 16, Ss, Sems	8
45	1001518	(00000000–	) Cable, Glv .13d 020.5l .38eye /.38eye	1
46	1001553	(00000000–	) Bushing, Sleeve, 0.25b 0.36d 0.16l, Stl	2
47	140000	(00000000–	) Washer, Flat, 0.28b 0.62d .04, Ss	2
48	140016	(00000000–	) Washer, Lock, Split, 0.25, Ss	2
49	600385	(00000000–	) Screw, Pan, Phl, M6 X 1.00 X 20, Ss	2

PAD DRIVER GROUP

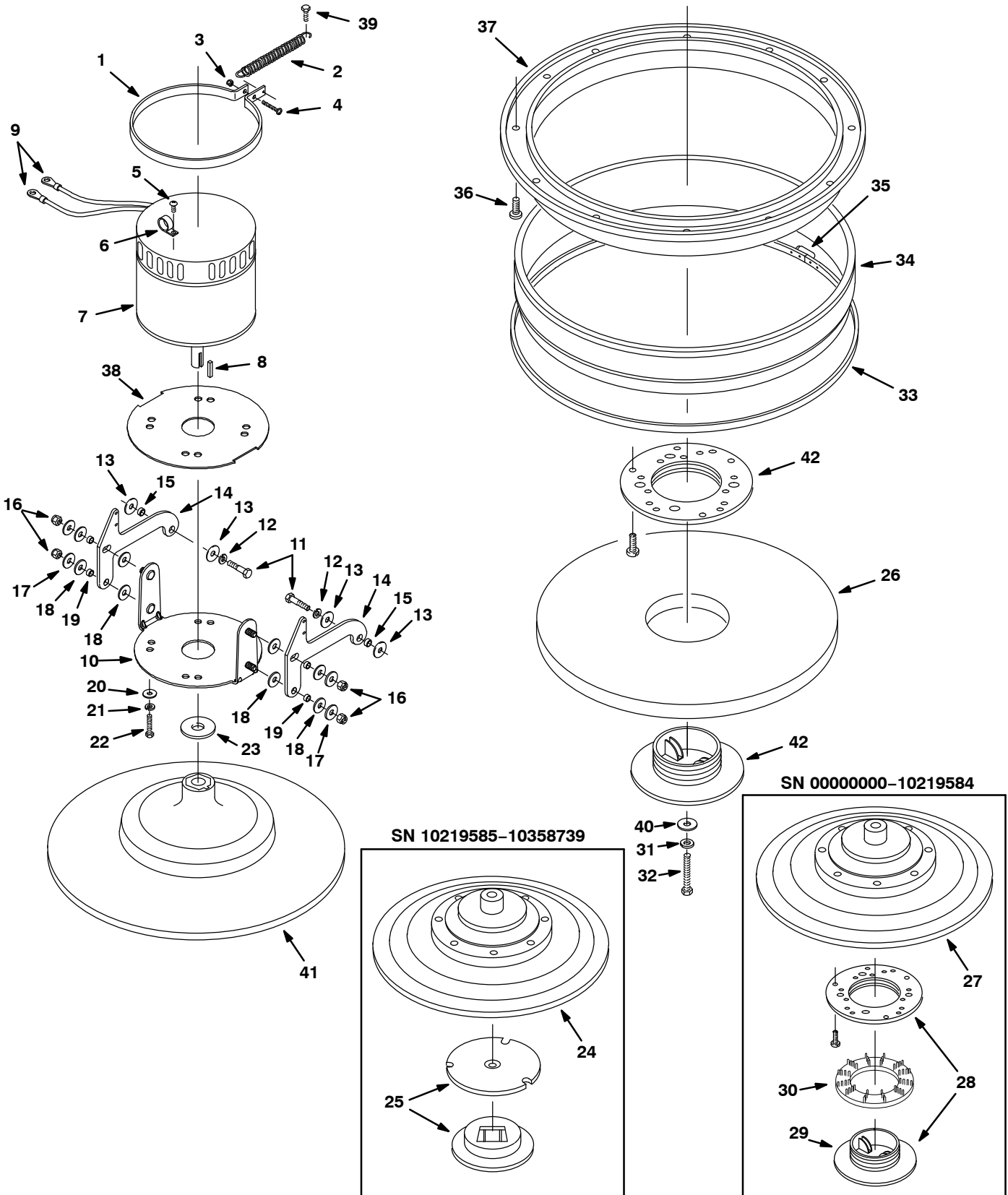

## PAD DRIVER GROUP

Ref.	Part No.	Serial Number	Description	Qty.
1	604278	(00000000-	) Bracket, Spring, Motor	1
2	604333	(00000000-	) Spring, Extn, 0.50od 0.06wir 04.0l	1
3	08712	(00000000-	) Nut, Hex, Lock, M6 X 1.00, NI, Ss	1
4	09258	(00000000-	) Screw, Pan, Phl, M6 X 1.00 X 40, 4.8	1
5	140890	(00000000-	) Screw, Trs, Phl, 10-24 X 0.50, Ss	1
6	140323	(00000000-	) Clamp, Cable, Nyl, 0.50d, Nat	1
▽	7	603398	(00000000-) ● Motor, Ele, 36vdc 2000rpm 3.00hp	1
		621478	(00000000-) ● Vr, Brush, Carbon [1pick=1pc]	4
▲	8	140628	(00000000-) Key, Sq, 0.19 X 0.19, 1.00l	1
▲	9	130162	(00000000-) Terminal, Ring, .25stud 08ga [Vi Rd]	2
10	1021186	(00000000-	) Bracket, Mtg, Motor	1
11	09745	(00000000-	) Screw, Hex, M12 X 1.75 X 25, Ss	2
12	140024	(00000000-	) Washer, Lock, Split, 0.50, Ss	2
13	140045	(00000000-	) Washer, Flat, 0.51b 1.25d .06, Ss	4
14	603273	(00000000-	) Arm, Lift, Motor	2
15	140139	(00000000-	) Sleeve, P/M, 0.50b 0.63d 0.3l, PI	2
16	36643	(00000000-	) Nut, Hex, Lock, .38-16, NI, Thin	4
17	140028	(00000000-	) Washer, Flat, 0.42b 1.00d .05, Ss	4
18	20536-2	(00000000-	) Washer, Flat, 0.50b 1.00d .03, Nyl	8
19	600191	(00000000-	) Sleeve, P/M, 0.38b 0.50d 0.2l, PI	4
20	140028	(00000000-	) Washer, Flat, 0.42b 1.00d .05, Ss	4
21	140017	(00000000-	) Washer, Lock, Split, 0.38, Ss	4
22	02994	(00000000-	) Screw, Hex, .38-16 X 0.75, Ss	4
23	069760023	(00000000-	) Washer, Flat, 0.77b 1.26d .03, Ss	1
▽	24	1019931	(10219585-10358739) ● Driver Assy, Pad, 20.0d, W/ Hub	1
▲	25	370095	(10219585-10358739) ● Device, Centering, Clip On, TI [Gf Pp]	1
	26	611788	(00000000-) ● Pad, 20.0[Burnish, Hairblend,1pick=1ctn]	1
▽	27	605348	(00000000-10219584) ● Driver Assy, Pad, 20.0d, W/ Hub	1
▲▽	28	32506	(00000000-10219584) ● Device, Centering, Rh Pad Retainer	1
▲	29	100101	(00000000-10219584) Device, Centering, Rh, 1.50l [Rem Ylw]	1
30	32505	(00000000-10219584) ● Washer, Flat, 92b 156d 2.6l, Pad Driver	1	
31	41186	(00000000-	) Washer, Flat, Belleville, .31	1
32	140203	(00000000-	) Screw, Hex, .31-24 X 1.25, PI	1
33	605103	(00000000-	) ● Skirt, Strip, 0.38 X 74.0	1
34	603744	(00000000-	) ● Skirt, Felt, .18, 01.60w 72.00l [2510]	1
35	230913	(00000000-	) Clamp, Screw [F/ Skirt Banding]	1
36	140340	(00000000-	) Screw, Pan, Phl, 10-24 X 0.62, Ss[Typ25]	6
37	230888	(00000000-	) Ring, Shield, Dust	1
38	600195	(00000000-	) Seal, Dust-Cntrl, Motor Base	1
39	600385	(00000000-	) Screw, Pan, Phl, M6 X 1.00 X 20, Ss	1
40	25732	(00000000-	) Washer, Flat, 0.36b 1.25d .09, PI	1
▽	41	1041196	(10358740-) ● Driver Assy, Pad, 20.0d, W/ Hub	1
▲	42	32506	(10358740-) ● Device, Centering, Rh Pad Retainer	1

▽ ASSEMBLY

▲ INCLUDED IN ASSEMBLY

● RECOMMENDED STOCK ITEMS

WHEEL GROUP, DRIVE (2550 MODEL)

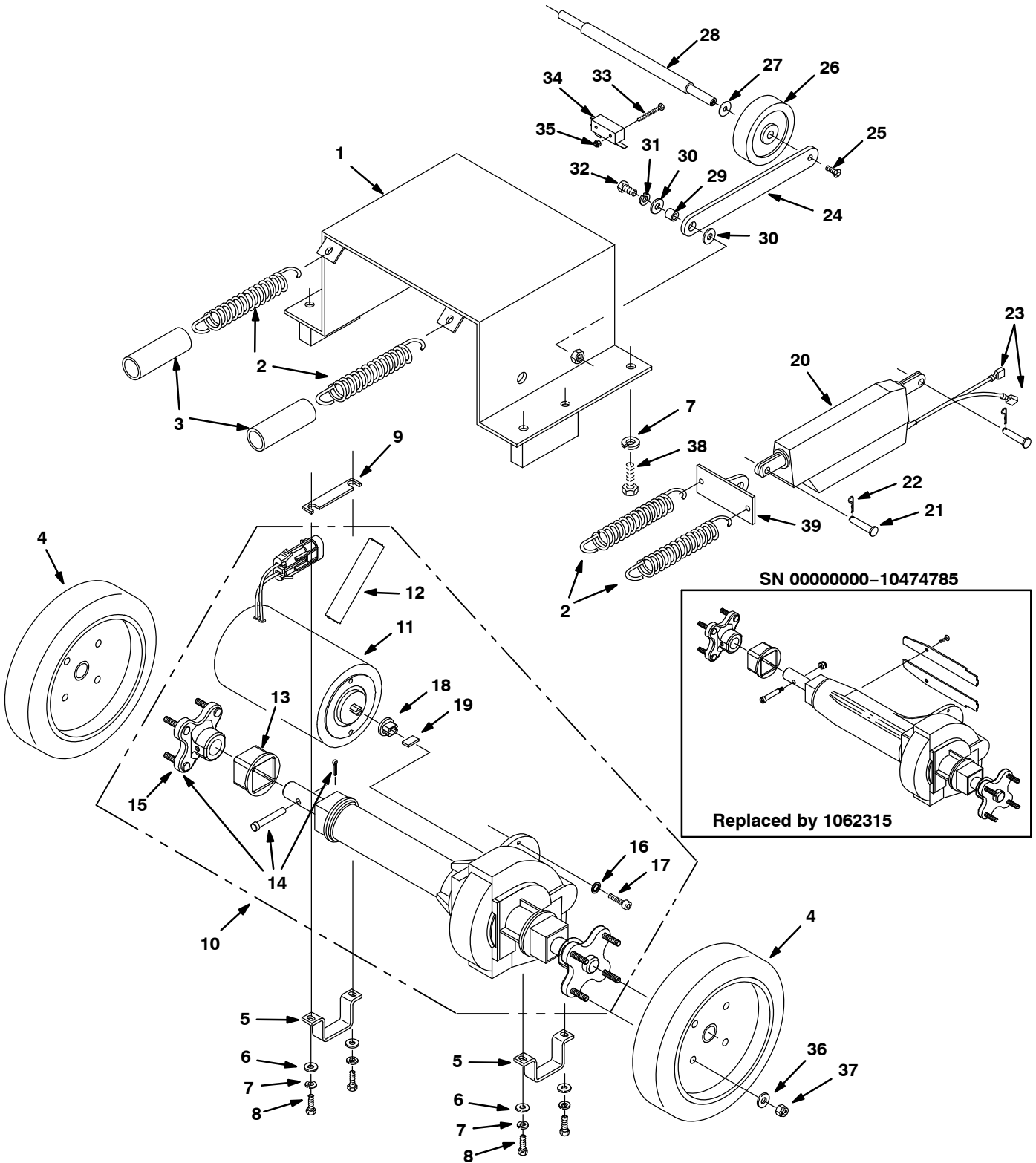

## WHEEL GROUP, DRIVE (2550 MODEL)

Ref.	Part No.	Serial Number	Description	Qty.	
1	603277	(00000000-	) Frame Wldt, Clr PI [2550/Speedglm]	1	
2	140431	(00000000-	) Spring, Extn, 1.00od 0.01wir 05.0l, Mw	4	
3	611023	(00000000-	) Sleeve, Spring, Rbr	2	
4	613026	(00000000-	)● Wheel, 08.0d 2.00w,4-Hole Mtg,Blk[Nitr]	2	
5	602881	(00000000-	) Bracket, Mtg, Transaxle, PI [2550/Spdgl]	2	
6	140028	(00000000-	) Washer, Flat, 0.42b 1.00d .05, Ss	4	
7	140333	(00000000-	) Washer, Lock, Split, M10, Ss	6	
8	06963	(00000000-	) Screw, Hex, M10 X 1.50 X 60, 8.8	4	
9	604293	(00000000-	) Spacer, Shim, .75w 4.0l .06th, 2sl, PI	1	
▽	10	1062315	(10474786-	) Transaxle, 36vdc, 116rpm, Mk400	1
	10	1007083	(10206962-10474785	) Transaxle, 36vdc, 116rpm (Replaced by 1062315)	1
	10	612845	(00000000-10206961	) Transaxle, 36vdc, 116rpm (Replaced by 1062315)	1
▲▽	11	612878	(00000000-	) Motor Kit, 36vdc, Replmt[612845 Trnsaxl]	1
▲▲	12	614166	(10206962-	)● Brush Kit, Carbon, Transaxle, Replmt [4] (For 1007083 & 1062315 Transaxles)	1
	12	612883	(00000000-10206961	)● Brush Kit, Carbon, Transaxle, 24/36vdc (For 612845 Transaxle)	1
▲	13	612880	(00000000-	) Joint, Transaxle, Replmt	2
▲▽	14	1063591	(00000000-	) Retainer, Hub, Transaxle Wheel	2
▲▲	15	612879	(00000000-	) Hub, Wheel, Transaxle Replmt	2
▲	16	32982	(00000000-	) Washer, Lock, Int, 0.25	2
▲	17	33951	(10206962-	) Screw, Soc, M6 X 1.00 X 20, 12.9	2
	17	01681	(00000000-10206961	) Screw, Soc, .25-20 X 0.75, Al	2
▲	18	612874	(00000000-	) Coupling, Transaxle, Replmt	1
▲	19	612875	(00000000-	) Key, Spcl, Transaxle Replmt	1
	20	600952	(00000000-	)● Actuator, 24vdc	1
	21	604076	(00000000-	) Pin, Clevis, M10d X 28, PI	2
	22	86866	(00000000-	) Pin, Cotter, Hair, 0.38d .072 Wir	2
	23	130133	(00000000-	) Terminal, Mal, .25 22-18ga Red, F-Ins	2
	24	603267	(00000000-	) Plate, Arm, Pivot	2
	25	069762098	(00000000-	) Screw, Flt, M6 X 1.0 X 16, Phl, Ss	2
	26	103066	(00000000-	)● Wheel, 04.0d 1.50w 0.50b, Gray	2
	27	140045	(00000000-	) Washer, Flat, 0.51b 1.25d .06, Ss	2
	28	603274	(00000000-	) Axle, .6d X 08.75l, Rear [2510/2550]	1
	29	140144	(00000000-	) Sleeve, P/M, 0.38b 0.50d 0.4l, PI	2
	30	140028	(00000000-	) Washer, Flat, 0.42b 1.00d .05, Ss	4
	31	140017	(00000000-	) Washer, Lock, Split, 0.38, Ss	2
	32	69225	(00000000-	) Screw, Hex, .38-16 X 1.00, Ss	2
	33	140829	(00000000-	) Screw, Pan, Phl, 06-32 X 1.00, Ss	2
	34	1013132	(00000000-	)● Switch, Lever, Snap Actn	1
	35	140539	(00000000-	) Nut, Hex, Lock, #06-32, Kep, Ss	2
	36	140000	(00000000-	) Washer, Flat, 0.28b 0.62d .04, Ss	8
	37	41169	(00000000-	) Nut, Hex, Lock, .25-20, NI, Ss	8
	38	09291	(00000000-	) Screw, Hex, M10 X 1.50 X 20, Ss	2
	39	609450	(00000000-	) Bracket Wldt, Spring	1

▽ ASSEMBLY

▲ INCLUDED IN ASSEMBLY

● RECOMMENDED STOCK ITEMS

WHEEL GROUP, PUSH (2510 MODEL)

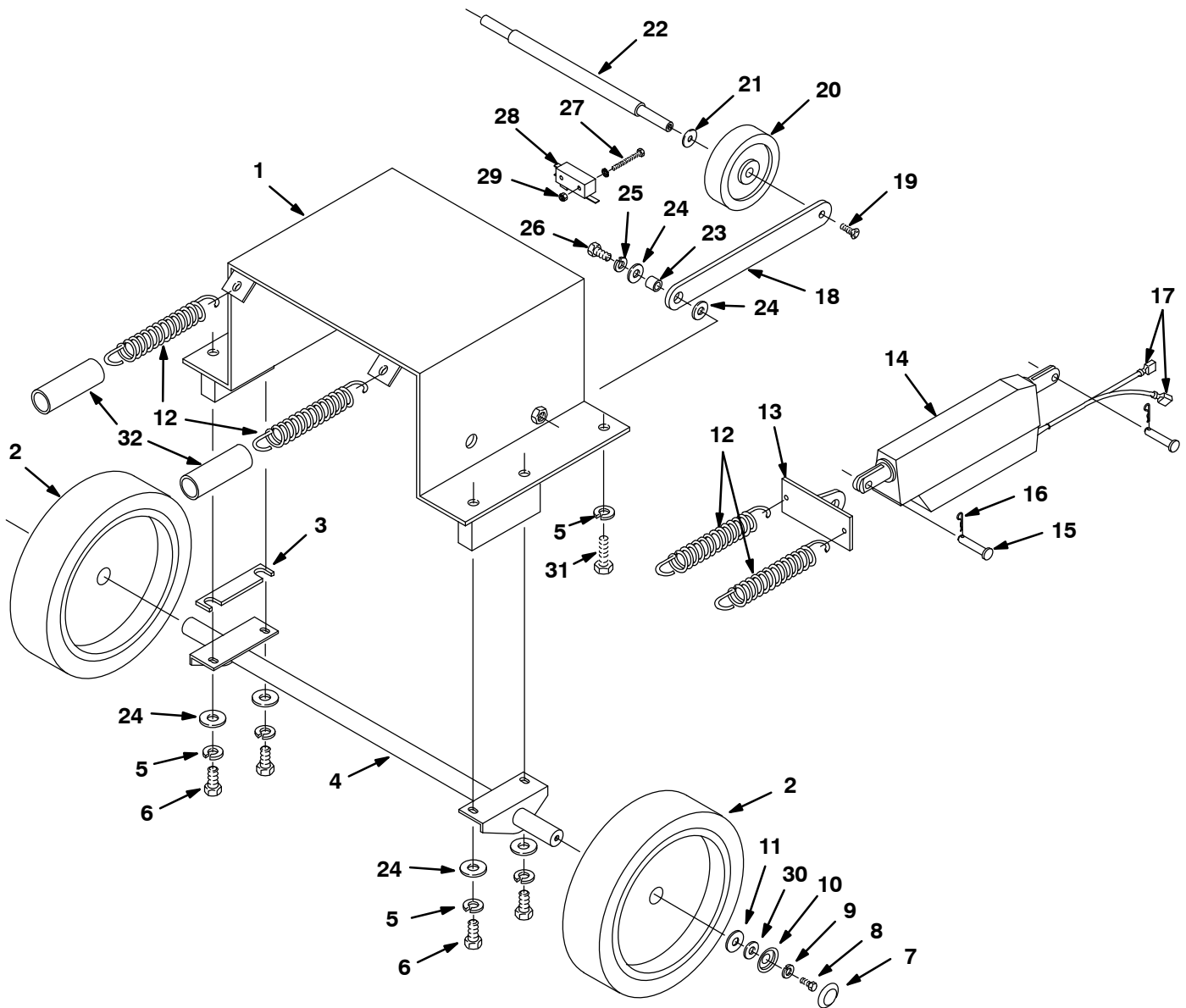

## WHEEL GROUP, PUSH (2510 MODEL)

Ref.	Part No.	Serial Number	Description	Qty.
1	603277	(00000000-	) Frame Wldt, Clr PI [2550/Speedglm]	1
2	1062636	(00000000-	)● Wheel, 8.0d 1.50w Polyurethane	2
3	604293	(00000000-	) Spacer, Shim, .75w 4.0l .06th, 2sl, PI	1
4	603275	(00000000-	) Axle Wldt, 0.75d X 19.12l [2510]	1
5	140333	(00000000-	) Washer, Lock, Split, M10, Ss	6
6	06963	(00000000-	) Screw, Hex, M10 X 1.50 X 60, 8.8	4
7	150210	(00000000-	) Plug, Cap, Blk	2
8	15675	(00000000-	) Screw, Hex, M8 X 1.25 X 16, Ss	2
9	140015	(00000000-	) Washer, Lock, Split, 0.31, Ss	2
10	140048	(00000000-	) Washer, 0.312	2
11	140047	(00000000-	) Washer, Flat, 0.75b 1.25d .06, Ss	2
12	140431	(00000000-	) Spring, Extn, 1.00od 0.01wir 05.0l, Mw	4
13	609450	(00000000-	) Bracket Wldt, Spring	1
14	600952	(00000000-	)● Actuator, 24vdc	1
15	604076	(00000000-	) Pin, Clevis, M10d X 28, PI	2
16	86866	(00000000-	) Pin, Cotter, Hair, 0.38d .072 Wir	2
17	130133	(00000000-	) Terminal, Mal, .25 22-18ga Red, F-Ins	2
18	603267	(00000000-	) Plate, Arm, Pivot	2
19	069762098	(00000000-	) Screw, Flt, M6 X 1.0 X 16, Phl, Ss	2
20	103066	(00000000-	) Wheel, 04.0d 1.50w 0.50b, Gray	2
21	140045	(00000000-	) Washer, Flat, 0.51b 1.25d .06, Ss	2
22	603274	(00000000-	) Axle, .6d X 08.75l, Rear [2510/2550]	1
23	140144	(00000000-	) Sleeve, P/M, 0.38b 0.50d 0.4l, PI	2
24	140028	(00000000-	) Washer, Flat, 0.42b 1.00d .05, Ss	8
25	140017	(00000000-	) Washer, Lock, Split, 0.38, Ss	2
26	69225	(00000000-	) Screw, Hex, .38-16 X 1.00, Ss	2
27	140829	(00000000-	) Screw, Pan, Phl, 06-32 X 1.00, Ss	2
28	1013132	(00000000-	)● Switch, Lever, Snap Actn	1
29	140539	(00000000-	) Nut, Hex, Lock, #06-32, Kep, Ss	2
30	30013	(00000000-	) Washer, Flat, 0.31, Fendr	2
31	09291	(00000000-	) Screw, Hex, M10 X 1.50 X 20, Ss	2
32	611023	(00000000-	) Sleeve, Spring, Rbr	2

● RECOMMENDED STOCK ITEMS

CONTROL CONSOLE GROUP (2550 MODEL)

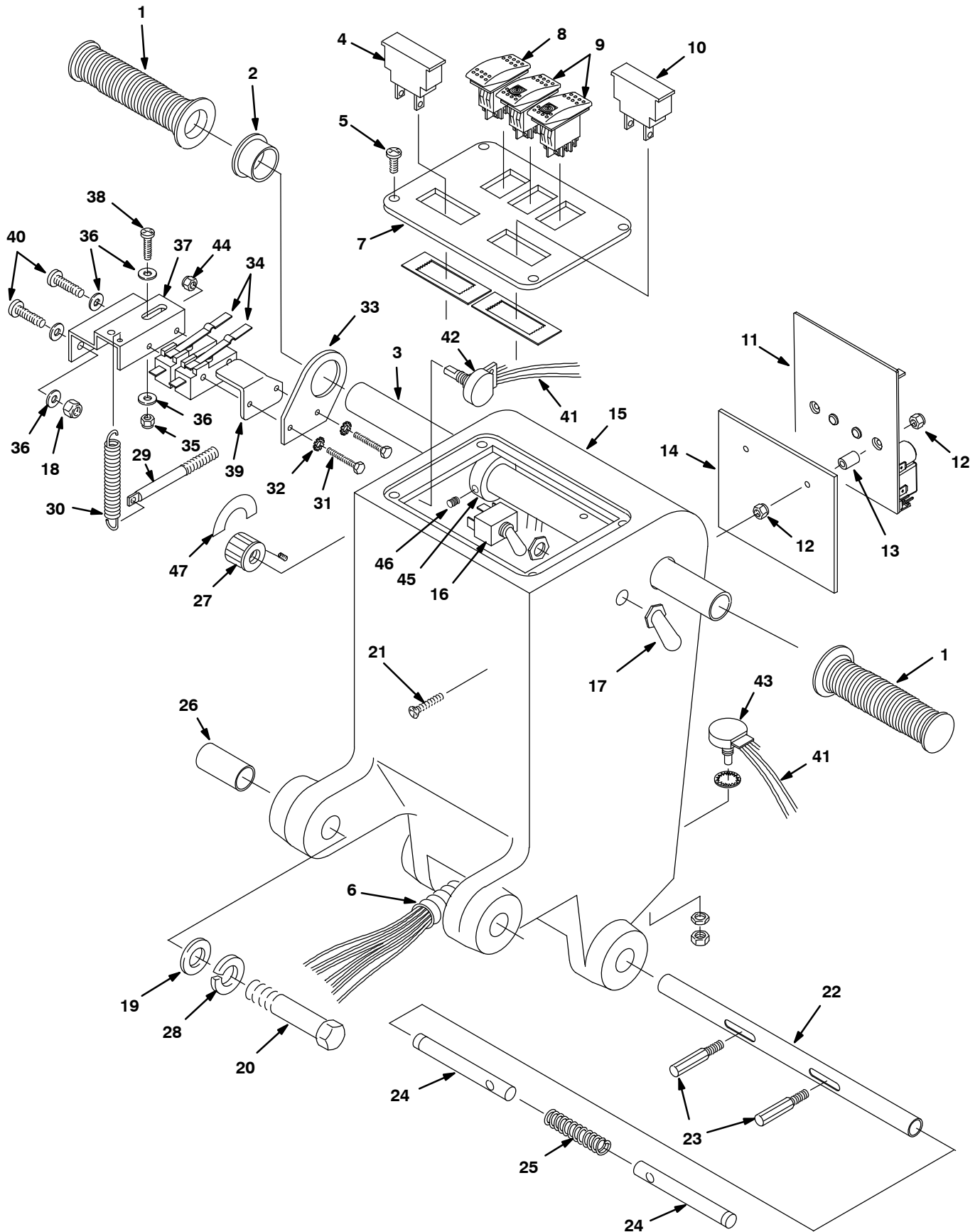



## CONTROL CONSOLE GROUP (2550 MODEL)

Ref.	Part No.	Serial Number	Description	Qty.
1	200823	(00000000-	) Grip, Handle Tube	2
2	605351	(00000000-	) Bushing, .88, Blk [10]	1
3	604402	(00000000-	) Tube, Handle	1
4	603848	(00000000-	)● Gauge, Ammeter, Rt, 36vdc [Pressure]	1
5	604930	(00000000-	) Screw, Trs, M5 X 0.80 X 10, Phl, Pl, NI	4
6	613086	(00000000-	) Harness, Main, Drive [2550]	1
	605840	(00000000-	) Conduit, .75d X 30.0 [Loom]	1
7	603757	(00000000-	) Panel, Switch [Spdgleam Plus]	1
8	603399	(00000000-	)● Switch, Push, Dpdt On/Off/Mom	1
9	601107	(00000000-	)● Switch, Rocker [Lighted]	2
10	603847	(00000000-	)● Gauge, Discharge, Battery, 36vdc	1
11	1000821	(00000000-	)● Controller, Propel, 36vdc	1
12	02850	(00000000-	) Nut, Hex, Lock, M4 X 0.70, NI	4
13	630261	(00000000-	) Tube, 0.19id 0.31od 00.5l, Alm	2
14	630128	(00000000-	) Heatsink, 11ga Alm, 104 X 120	1
15	607556	(00000000-	) Housing, Cntrl, Rm-TI, Trimmed	1
16	601108	(00000000-	)● Switch, Toggle, Mom	1
17	130753	(00000000-	) Boot, Switch, .47-32 , 1.00l, Blk [2550]	1
18	08712	(00000000-	) Nut, Hex, Lock, M6 X 1.00, NI, Ss	2
19	140045	(00000000-	) Washer, Flat, 0.51b 1.25d .06, Ss	2
20	140351	(00000000-	) Screw, Hex, M12 X 1.75 X 70, PI	2
21	630304	(00000000-	) Screw, Flt, Phl, M4 X 0.70 X 35, 4.8	2
22	230715	(00000000-	) Tube, Handle, Adj [Ctx]	1
23	230649	(00000000-	) Pin, Handle, Adjmt	2
24	230710	(00000000-	) Pin, Handle, Lock	2
25	140415	(00000000-	) Spring, Lock Pin	1
26	140155	(00000000-	) Bushing, .48 X .62 X 2.00	2
27	606550	(00000000-	) Knob, Rnd, 0.92d 0.76l 0.25b, Plstc	1
28	140024	(00000000-	) Washer, Lock, Split, 0.50, Ss	2
29	602886	(00000000-	) Pin, Spring, Hanger, .31-18thrd X .94,PI	1
30	605812	(00000000-	) Spring, Extn	1
31	1048847	(00000000-	) Screw, Hex, 06-32 X 1.75 Fl, Ss	2
32	140019	(00000000-	) Washer, Lock, Ext, 06	2
33	27098	(00000000-	) Bracket, Switch	1
34	614003	(00000000-	)● Switch, Snap, W/ Bump	2
35	140552	(00000000-	) Nut, Hex, Lock, #10-24, NI, Ss	1
36	140000	(00000000-	) Washer, Flat, 0.28b 0.62d .04, Ss	5
37	25671	(00000000-	) Mount, Switch	1
38	140890	(00000000-	) Screw, Trs, Phl, 10-24 X 0.50, Ss	1
39	603830	(00000000-	) Plate, Guard, Switch	1
40	608322	(00000000-	) Screw, Trs, M6 X 1.00 X 16, Phl, Ss	2
▽	41	602873	)● Harness, Console, W/ Pot	1
▲	42	130776	)● Potentiometer	1
▲	43	130775	)● Potentiometer, 50k - Lockable	1
	44	140540	) Nut, Hex, Std, #06-32, Ss	2
	45	605094	) Collar, Handle	2
	46	140859	) Screw, Set, .25-20 X 0.25, Soc	2
	47	606549	) Label, Spd Cntrl	1

▽ ASSEMBLY

▲ INCLUDED IN ASSEMBLY

● RECOMMENDED STOCK ITEMS

CONTROL CONSOLE GROUP (2510 MODEL)

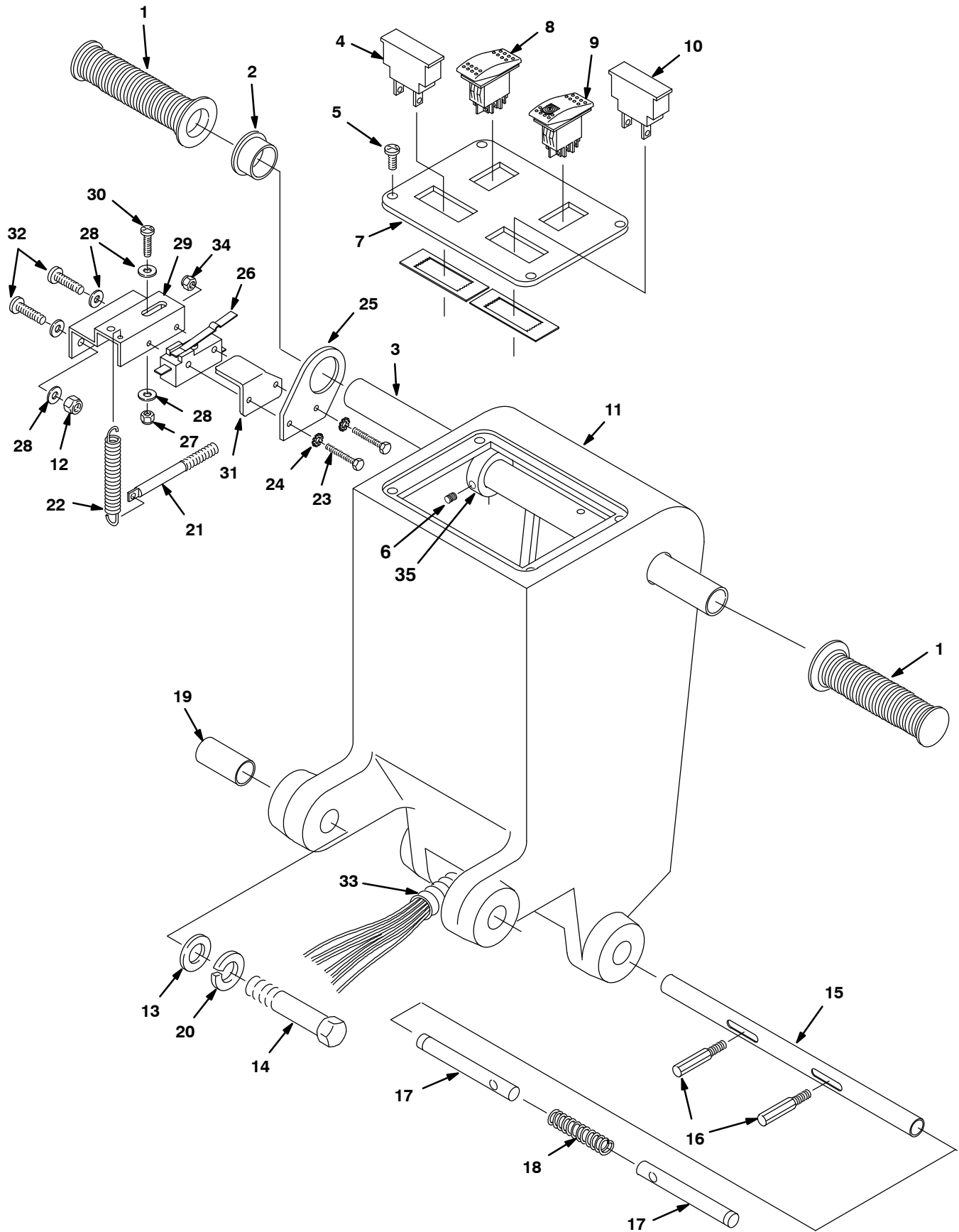

## CONTROL CONSOLE GROUP (2510 MODEL)

Ref.	Part No.	Serial Number	Description	Qty.
1	200823	(00000000-	) Grip, Handle Tube	2
2	605351	(00000000-	) Bushing, .88, Blk [10]	1
3	604402	(00000000-	) Tube, Handle	1
4	603848	(00000000-	)● Gauge, Ammeter, Rt, 36vdc [Pressure]	1
5	604930	(00000000-	) Screw, Trs, M5 X 0.80 X 10, Phl, Pl, NI	4
6	140859	(00000000-	) Screw, Set, .25-20 X 0.25, Soc	2
7	604269	(00000000-	) Panel, Switch [Spdgleam]	1
8	603399	(00000000-	)● Switch, Push, Dpdt On/Off/Mom	1
9	601107	(00000000-	)● Switch, Rocker [Lighted]	1
10	603847	(00000000-	)● Gauge, Discharge, Battery, 36vdc	1
11	607604	(00000000-	) Housing, Cntrl, Rm-TI, Trimmed	1
12	08712	(00000000-	) Nut, Hex, Lock, M6 X 1.00, NI, Ss	2
13	140045	(00000000-	) Washer, Flat, 0.51b 1.25d .06, Ss	2
14	140351	(00000000-	) Screw, Hex, M12 X 1.75 X 70, PI	2
15	230715	(00000000-	) Tube, Handle, Adj [Ctx]	1
16	230649	(00000000-	) Pin, Handle, Adjmt	2
17	230710	(00000000-	) Pin, Handle, Lock	2
18	140415	(00000000-	) Spring, Lock Pin	1
19	140155	(00000000-	) Bushing, .48 X .62 X 2.00	2
20	140024	(00000000-	) Washer, Lock, Split, 0.50, Ss	2
21	602886	(00000000-	) Pin, Spring, Hanger, .31-18thrd X .94,PI	1
22	605812	(00000000-	) Spring, Extn	1
23	1048848	(00000000-	) Screw, Hex, 06-32 X 1.00 Fl, S/S	2
24	140019	(00000000-	) Washer, Lock, Ext, 06	2
25	27098	(00000000-	) Bracket, Switch	1
26	614003	(00000000-	)● Switch, Snap, W/ Bump	1
27	140552	(00000000-	) Nut, Hex, Lock, #10-24, NI, Ss	1
28	140000	(00000000-	) Washer, Flat, 0.28b 0.62d .04, Ss	5
29	25671	(00000000-	) Mount, Switch	1
30	140890	(00000000-	) Screw, Trs, Phl, 10-24 X 0.50, Ss	1
31	603830	(00000000-	) Plate, Guard, Switch	1
32	608322	(00000000-	) Screw, Trs, M6 X 1.00 X 16, Phl, Ss	2
33	606539	(00000000-	) Harness, Main, Push [2510]	1
	605840	(00000000-	) Conduit, .75d X 30.0 [Loom]	1
34	140540	(00000000-	) Nut, Hex, Std, #06-32, Ss	2
35	605094	(00000000-	) Collar, Handle	2

● RECOMMENDED STOCK ITEMS

ELECTRICAL GROUP

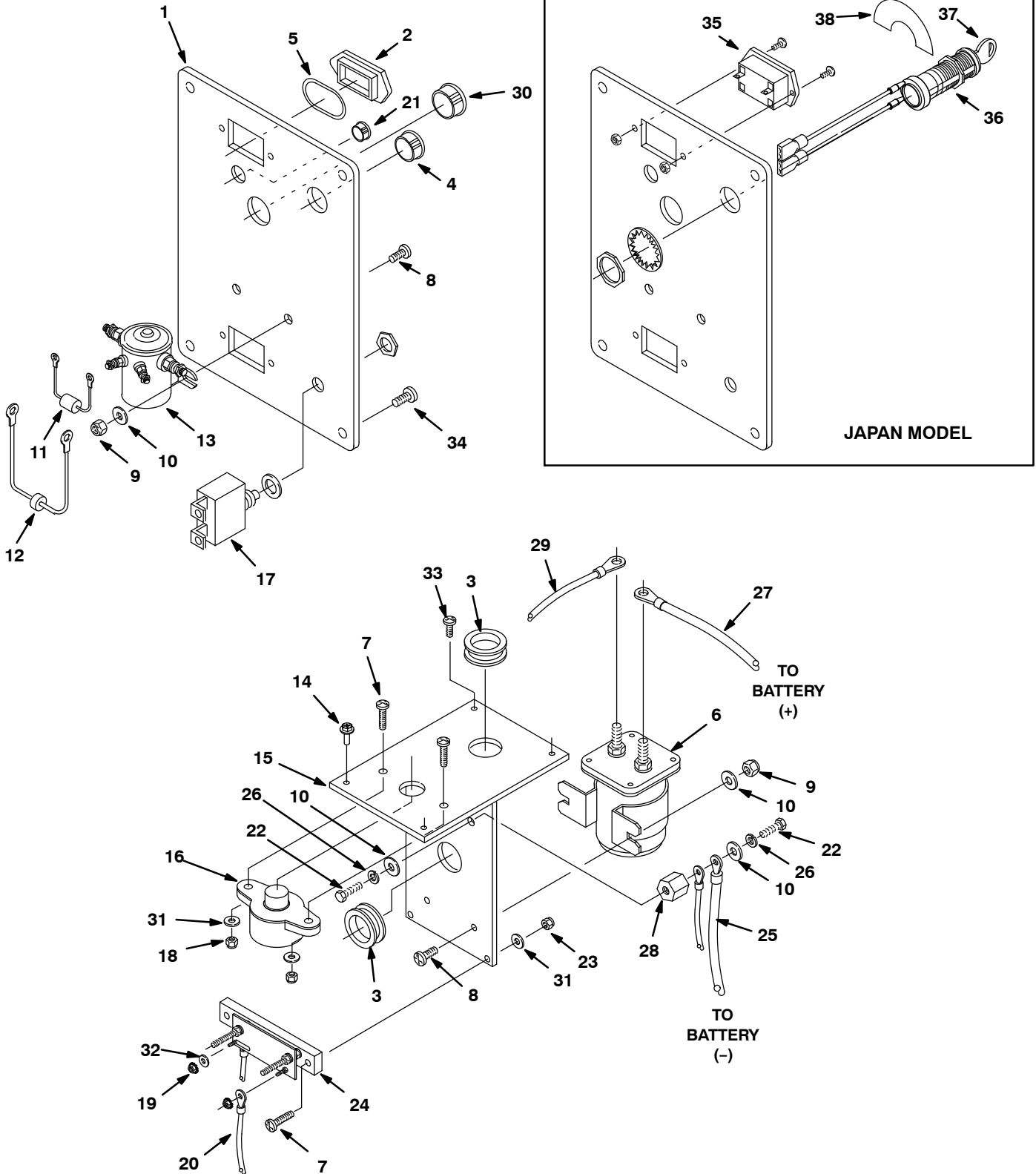

## ELECTRICAL GROUP

Ref.	Part No.	Serial Number	Description	Qty.
1	604939	(00000000-	) Panel, Cntrl, Rear	1
2	609969	(00000000-	) Plug, Hole, Hourmeter, Blk	2
3	069762009	(00000000-	) Grommet, 25.4d X 03mm Th, Grv	2
4	130175	(00000000-	) Plug, Hole, Rnd, 0.75d, Blk	1
5	605823	(00000000-	) Seal, Org .926id X .99600	2
6	612766	(00000000-	)● Solenoid, 36vdc [Cont Duty Bear]	1
7	24196	(00000000-	) Screw, Pan, Phl, M5 X 0.80 X 20, Ss	4
8	608322	(00000000-	) Screw, Trs, M6 X 1.00 X 16, Phl, Ss	4
9	08712	(00000000-	) Nut, Hex, Lock, M6 X 1.00, NI, Ss	4
10	140000	(00000000-	) Washer, Flat, 0.28b 0.62d .04, Ss	6
11	606404	(00000000-	)● Diode Assy, W/ Ring Terminals	1
12	604486	(00000000-	)● Diode Assy [Spliced]	1
13	130733	(00000000-	)● Contactor, Solenoid, 36vdc, Sp, No	1
14	1034731	(00000000-	) Screw, Hex, M6 X 1.00 X 16, Ss, Sems	3
15	604271	(00000000-	) Bracket Wldt, Chassis, Ele	1
16	130781	(00000000-	)● Circuitbreaker, 80.0a	1
17	603487	(00000000-	)● Circuitbreaker, 15.0a, Brush	1
18	09739	(00000000-	) Nut, Hex, Lock, M5 X 0.80, NI, Ss	2
19	140524	(00000000-	) Nut, Hex, Lock, .25-20, Kep	2
20	604292	(00000000-	) Cable, 04ga 06.0l Blk .25ring /.25ring	1
21	604940	(00000000-	) Plug, Hole, Rnd, 0.31h 0.3l, Blk Nyl	1
22	01696	(00000000-	) Screw, Hex, .25-20 X 0.50, Ss	2
23	09739	(00000000-	) Nut, Hex, Lock, M5 X 0.80, NI, Ss	2
24	605292	(00000000-	) Shunt	1
25	604290	(00000000-	) Cable, 04ga 27.0l Blk .25ring /.31ring	1
26	140016	(00000000-	) Washer, Lock, Split, 0.25, Ss	2
27	604289	(00000000-	) Cable, 04ga 46.0l Red .31ring /.38ring	1
28	76062	(00000000-	) Stand-Off, Wir, M6, Insulator, Panel	1
29	604291	(00000000-	) Cable, 04ga 05.5l Blk .25ring /.31ring	1
30	130161	(00000000-	) Plug, Hole, Rnd, 0.88d, Blk	1
31	140011	(00000000-	) Washer, Flat, 0.21b 0.45d .03, Ss	4
32	140026	(00000000-	) Washer, Flat, 0.16b 0.38d .05, PI, 06	1
33	140340	(00000000-	) Screw, Pan, Phl, 10-24 X 0.62, Ss[Typ25]	1
34	604930	(00000000-	) Screw, Trs, M5 X 0.80 X 10, Phl, PI, NI	4
35	1010555	(00000000-	)● Gauge, Hourmeter, 14-48vdc, Lcd, Rt (Japan Model)	1
▽	36	607475	(00000000-)● Switch, 12a [Keylock] (Japan Model)	1
▲	37	607821	(00000000-)● Key, Stl, Replmt (Japan Model)	1
	38	604793	(00000000-) Label, Keyswitch On(1) / Off(0) (Japan Model)	1

▽ ASSEMBLY

▲ INCLUDED IN ASSEMBLY

● RECOMMENDED STOCK ITEMS

# STANDARD PARTS

## BATTERY GROUP, LEAD ACID 12V/225AH

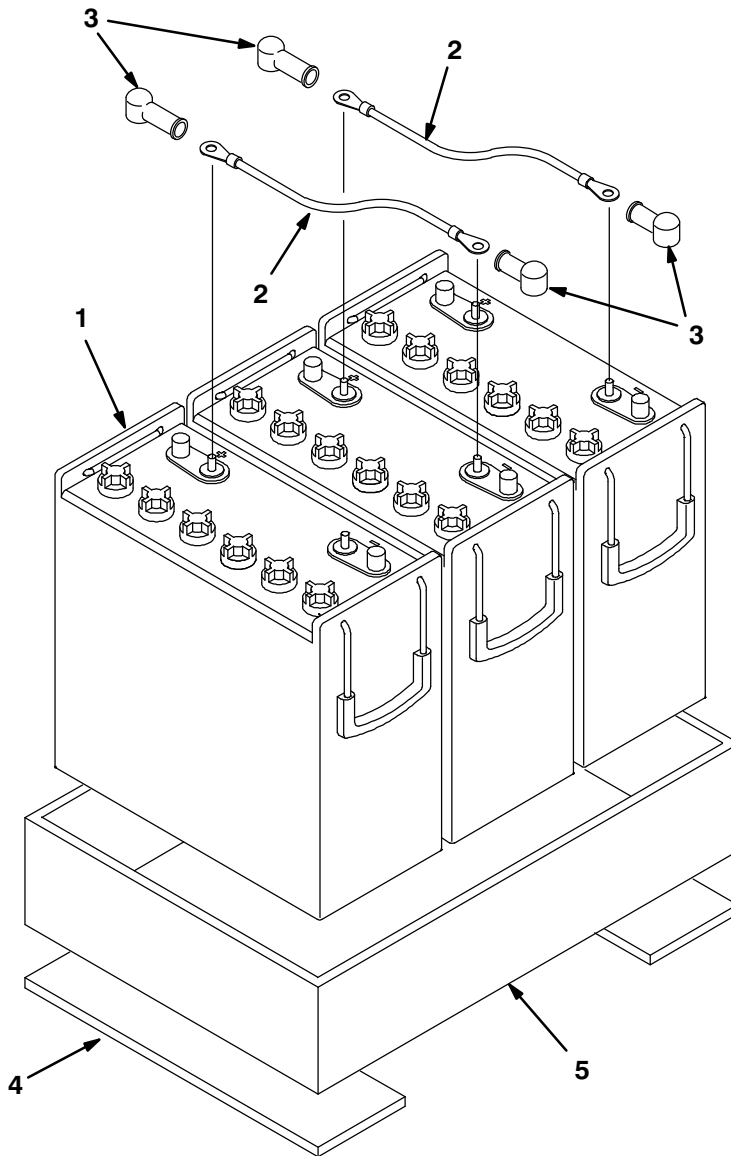

Ref.	Part No.	Serial Number	Description	Qty.
1	600394	(00000000-)	)● Battery, 12vdc 0225ah, Dual Post	3
2	611116000	(00000000-)	)● Cable, Battery, 04ga, 0305mml	2
3	611221	(00000000-)	)● Boot, Terminal, Battery, 25.4mm, Blk	6
4	611022	(00000000-)	) Gasket, Ure, .25, 03.50w 15.25l, Adh	2
5	604298	(00000000-)	) Tray, Battery, Rm-Blk, Trim[2510/Spdglm]	1

● RECOMMENDED STOCK ITEMS

BATTERY GROUP, AGM 12V/234AH

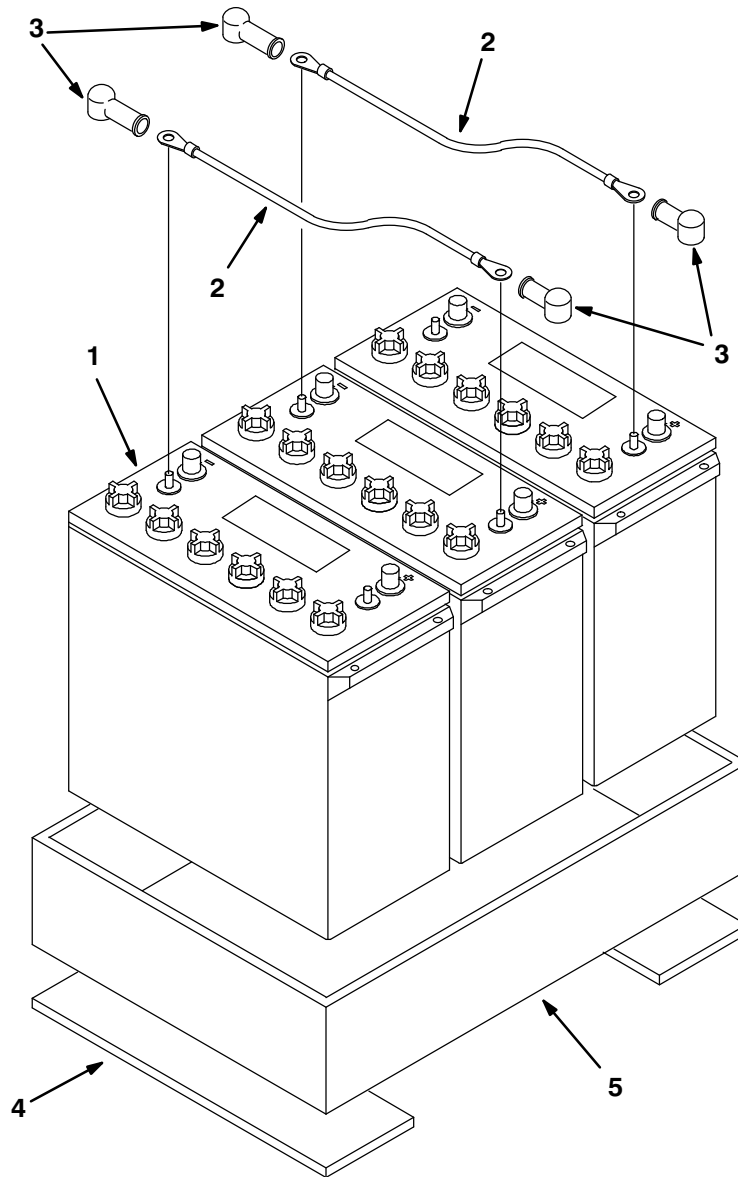

Ref.	Part No.	Serial Number	Description	Qty.
1	1053427	(00000000-	)● Battery, 12vdc 0234ah Agm	3
2	223364	(00000000-	)● Cable, 04ga 18.0l Blk .34ring /.34ring	2
3	611221	(00000000-	)● Boot, Terminal, Battery, 25.4mm, Blk	6
4	611022	(00000000-	) Gasket, Ure, .25, 03.50w 15.25l, Adh	2
5	604298	(00000000-	) Tray, Battery, Rm-Blk, Trim[2510/Spdglm]	1

● RECOMMENDED STOCK ITEMS

OFF-BOARD BATTERY CHARGER GROUP

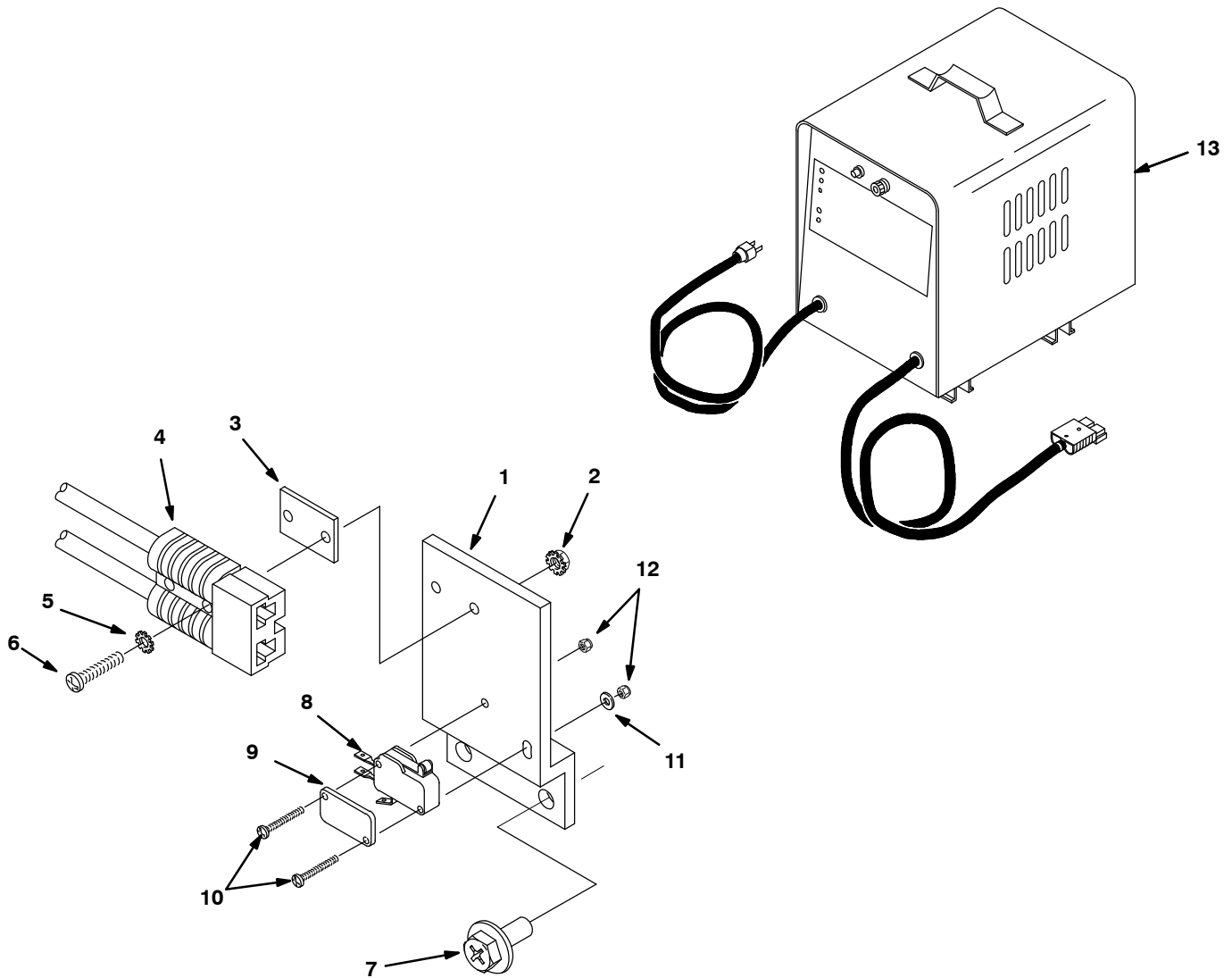

Ref.	Part No.	Serial Number	Description	Qty.
1	604270	(00000000-	) Bracket, Plug, Chrgr	1
2	140539	(00000000-	) Nut, Hex, Lock, #06-32, Kep, Ss	2
3	603331	(00000000-	) Spacer, Plug, Chrgr	1
4	604288	(00000000-	) Wire Assy, 10ga /2 .31ring /.38ring 050a	1
5	140019	(00000000-	) Washer, Lock, Ext, 06	2
6	140829	(00000000-	) Screw, Pan, Phl, 06-32 X 1.00, Ss	2
7	1034731	(00000000-	) Screw, Hex, M6 X 1.00 X 16, Ss, Sems	2
8	600437	(00000000-	) ● Switch, Snap, 15a, Rlr	1
9	601359	(00000000-	) Plate, Backing, Switch	1
10	578403000	(00000000-	) Screw, Pan, M3 X 0.5 X 20, Phl, Pl	2
11	601127000	(00000000-	) Washer, Flat, 0.15b 0.31d .02, Pl, M3	1
12	579211	(00000000-	) Nut, Hex, Lock, M3 X 0.50, NI, Ss	2
13	469760868	(00000000-	) ● Charger, 36vac, 25a [F/ 215-305ah]	1

● RECOMMENDED STOCK ITEMS



ON-BOARD BATTERY CHARGER GROUP

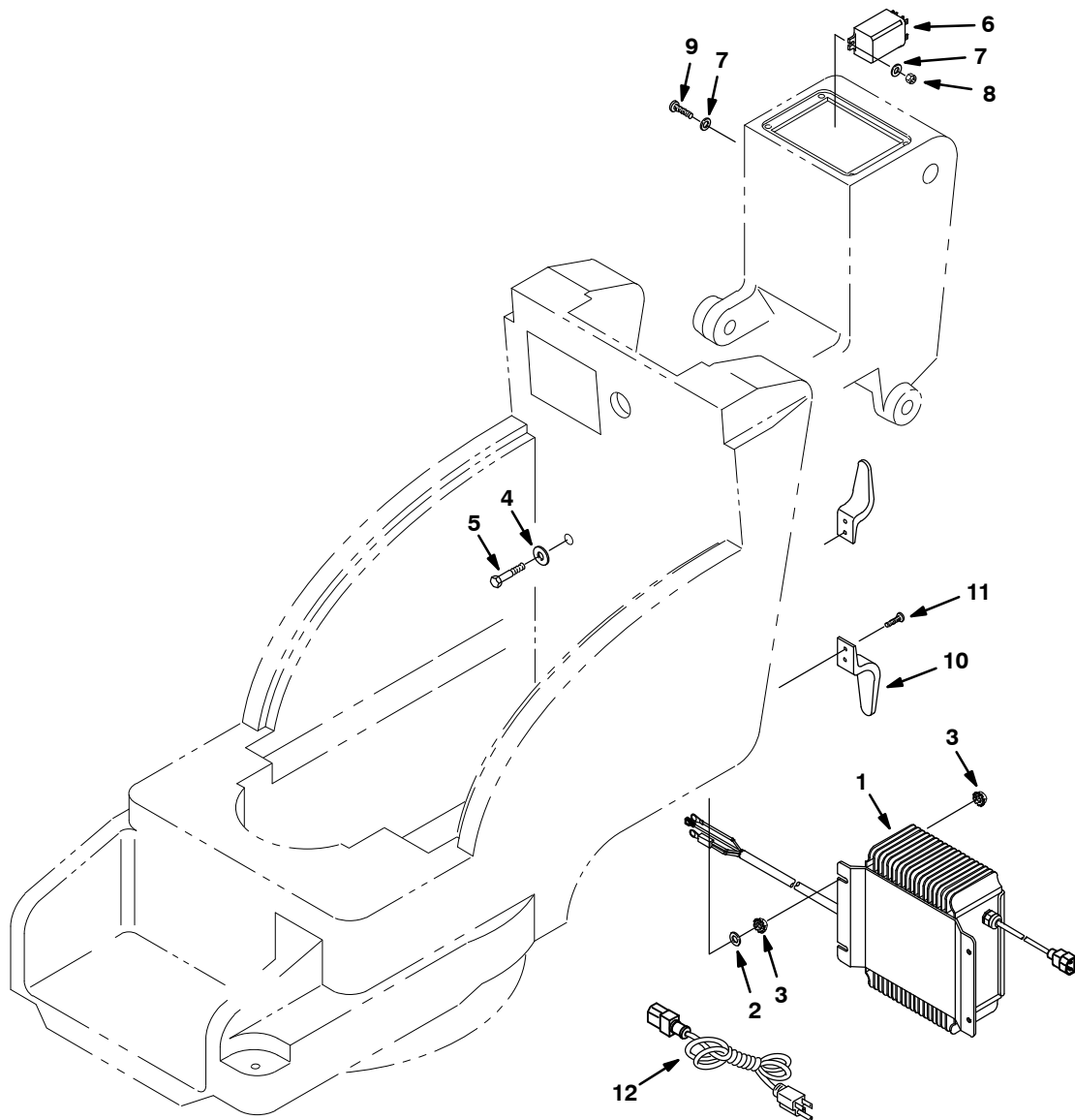

Ref.	Part No.	Serial Number	Description	Qty.
1	1037826	(00000000-)	) Charger, 36vdc, 21a Var Vac [Onboard]	1
1	1053426	(00000000-)	) Charger, 36vdc, 21a Var Vac[Onboard Agm]	1
2	200315016	(00000000-)	) Washer, Flat, M5.3b X 15.0d X 1.6, PI	4
3	07789	(00000000-)	) Nut, Hex, Flng, M5 X 0.80	8
4	019680127	(00000000-)	) Washer, Flat, 6.2mm Id X 22.0mm Od X 1.9	4
5	575732	(00000000-)	) Screw, Hex, M5 X 0.80 X 40	4
6	86366	(00000000-)	) Relay, 36vdc, 030a, Spdt [Midland]	1
7	140026	(00000000-)	) Washer, Flat, 0.16b 0.38d .05, PI, 06	4
8	579211	(00000000-)	) Nut, Hex, Lock, M3 X 0.50, NI, Ss	2
9	200070266	(00000000-)	) Screw, Pan, Phl, M3 X 0.50 X 16, PI	2
10	230920.BK	(00000000-)	) Hook, Cord, Blk [Boss]	2
11	1009324	(00000000-)	) Screw, Pan, Phl, 10-16 X 0.50,Blk[Typ17]	4
12	1017079	(00000000-)	)● Cord, Extn, 16ga /3, 10ft [Sjt]	1

● RECOMMENDED STOCK ITEMS

## WIRING DIAGRAM 2550 MODEL WITH ON-BOARD CHARGER

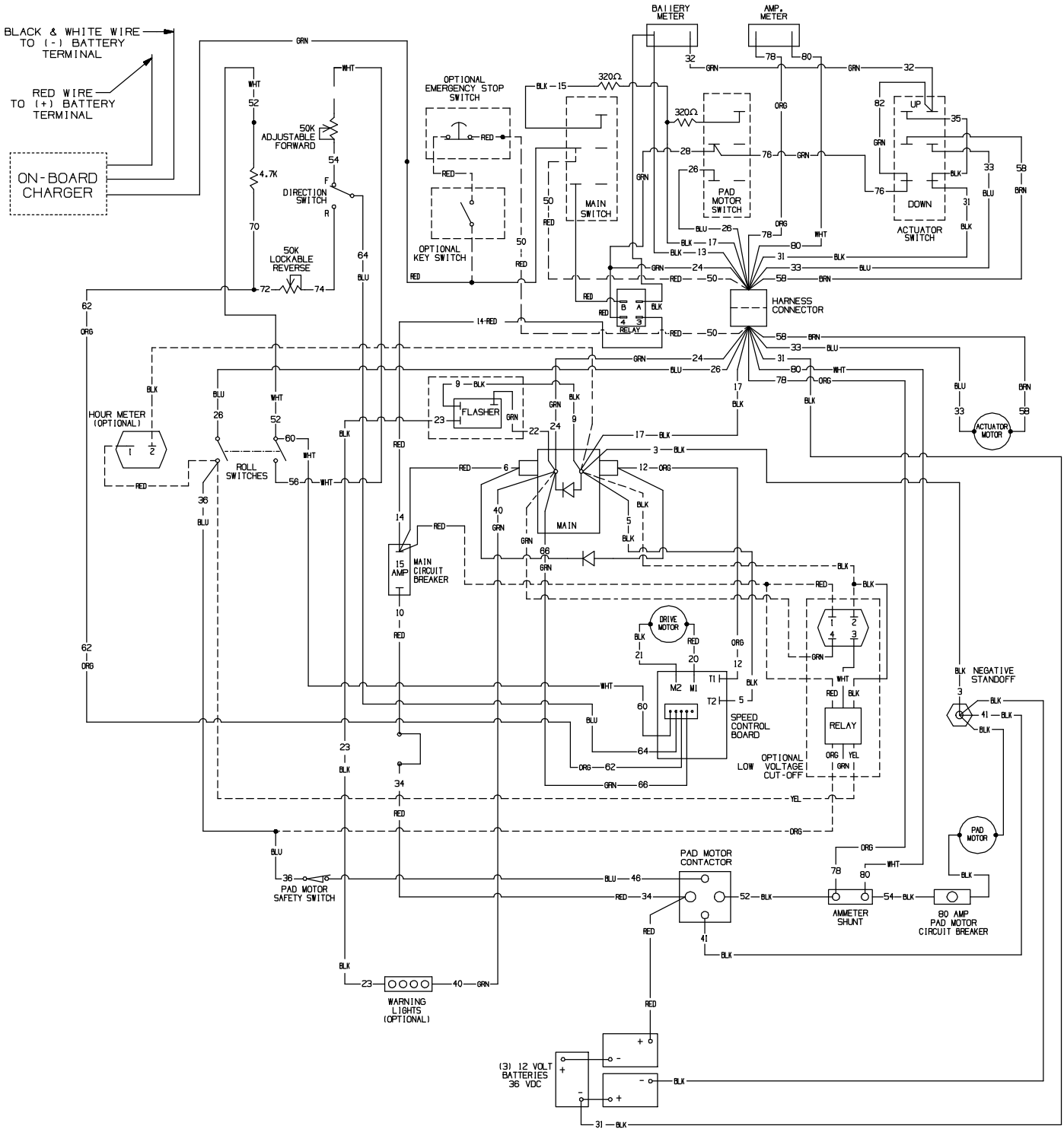

DWG # 1042608

LADDER DIAGRAM 2550 MODEL WITH ON-BOARD CHARGER

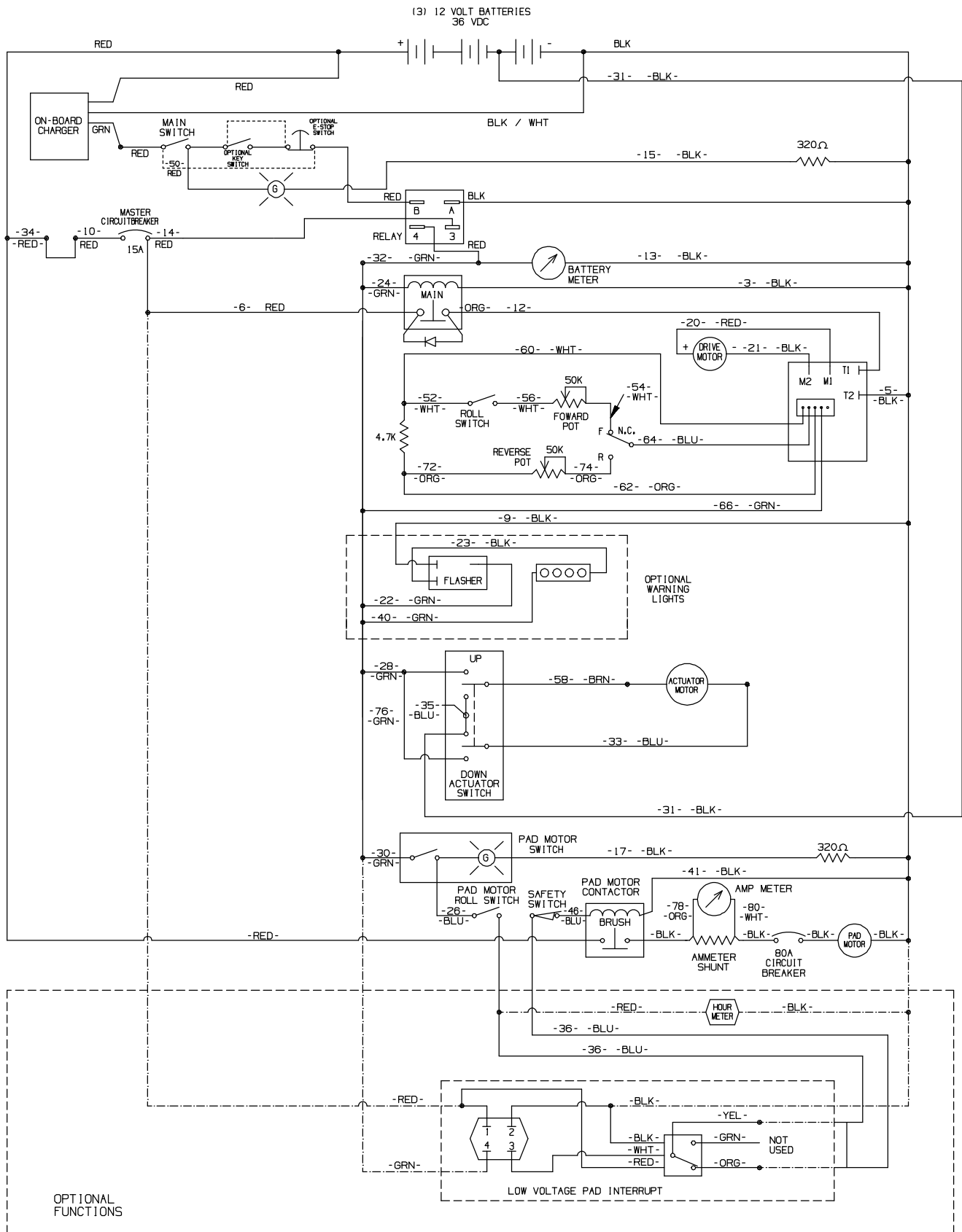

DWG # 1042588

## WIRING DIAGRAM 2550 MODEL WITHOUT ON-BOARD CHARGER

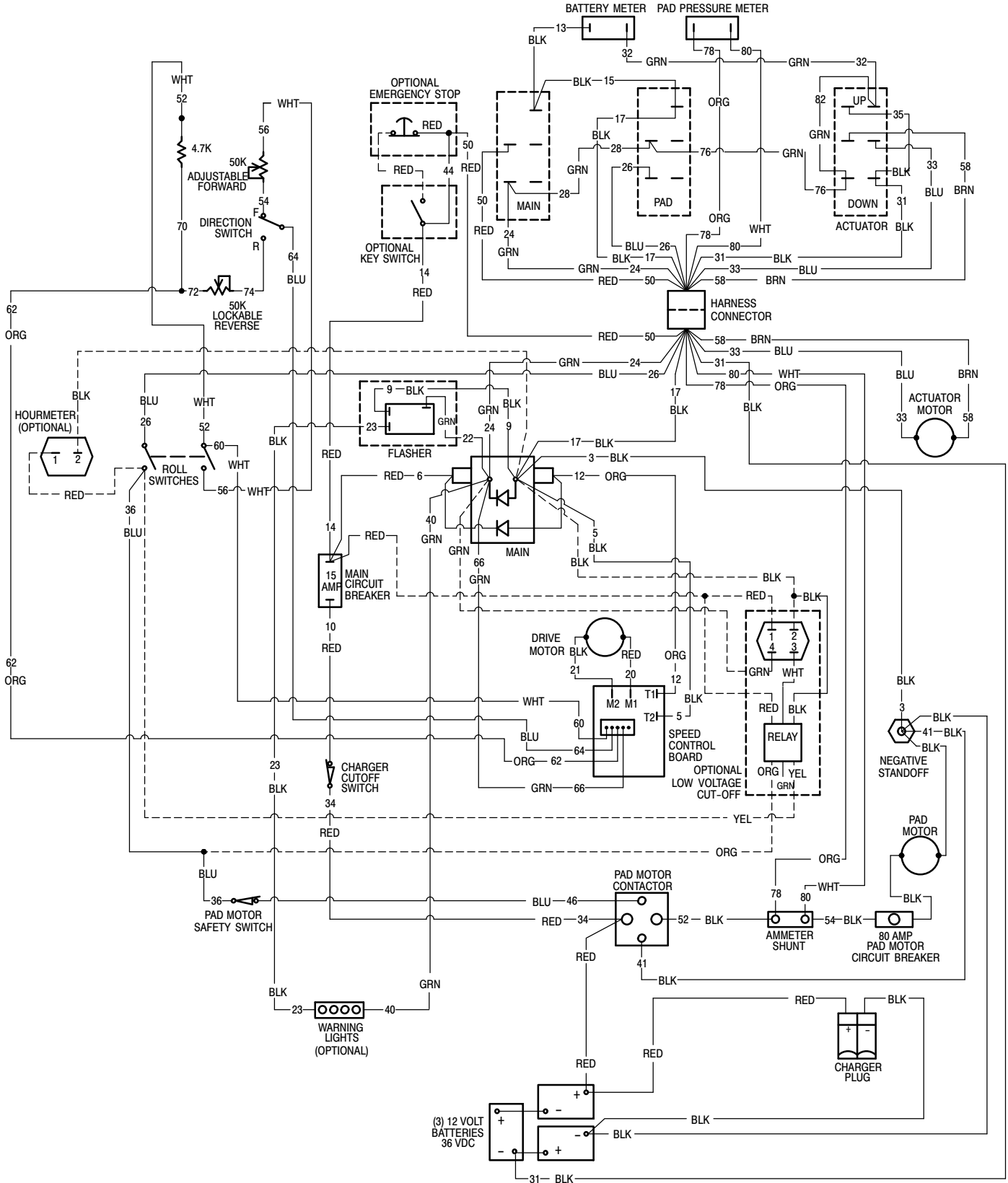

LADDER DIAGRAM 2550 MODEL WITHOUT ON-BOARD CHARGER

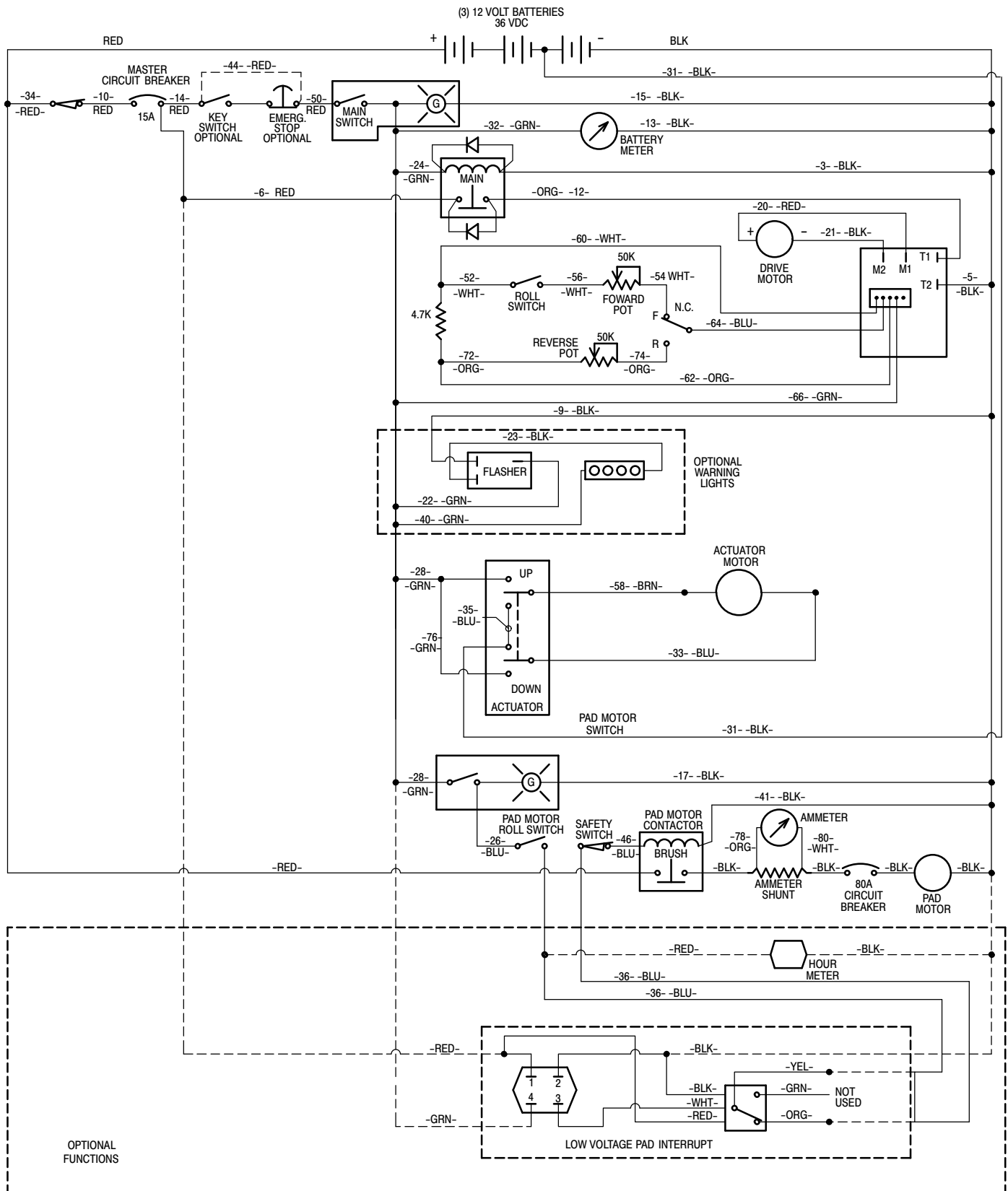

## WIRING DIAGRAM 2510 MODEL WITH ON-BOARD CHARGER

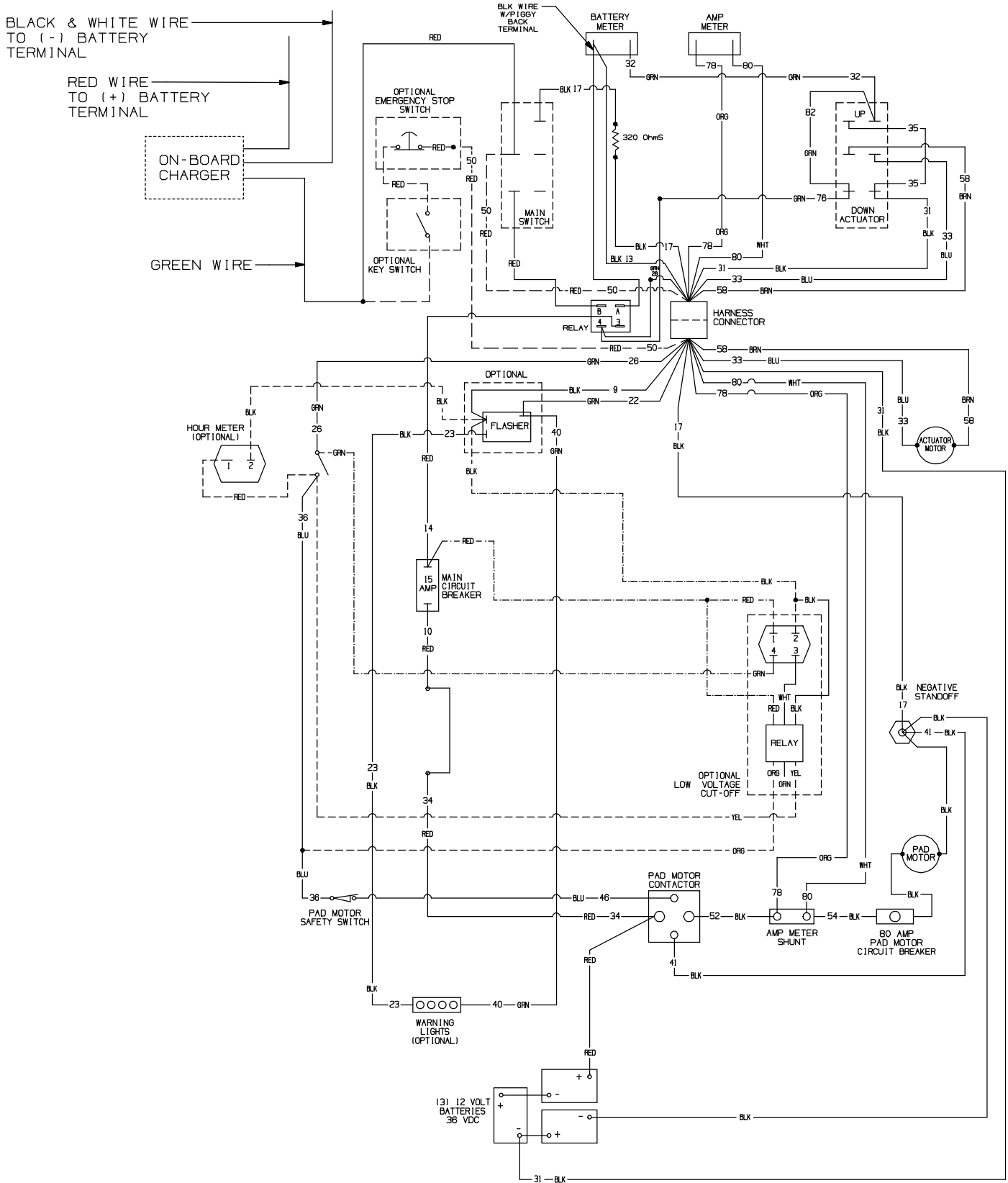

DWG #1042613

LADDER DIAGRAM 2510 MODEL WITH ON-BOARD CHARGER

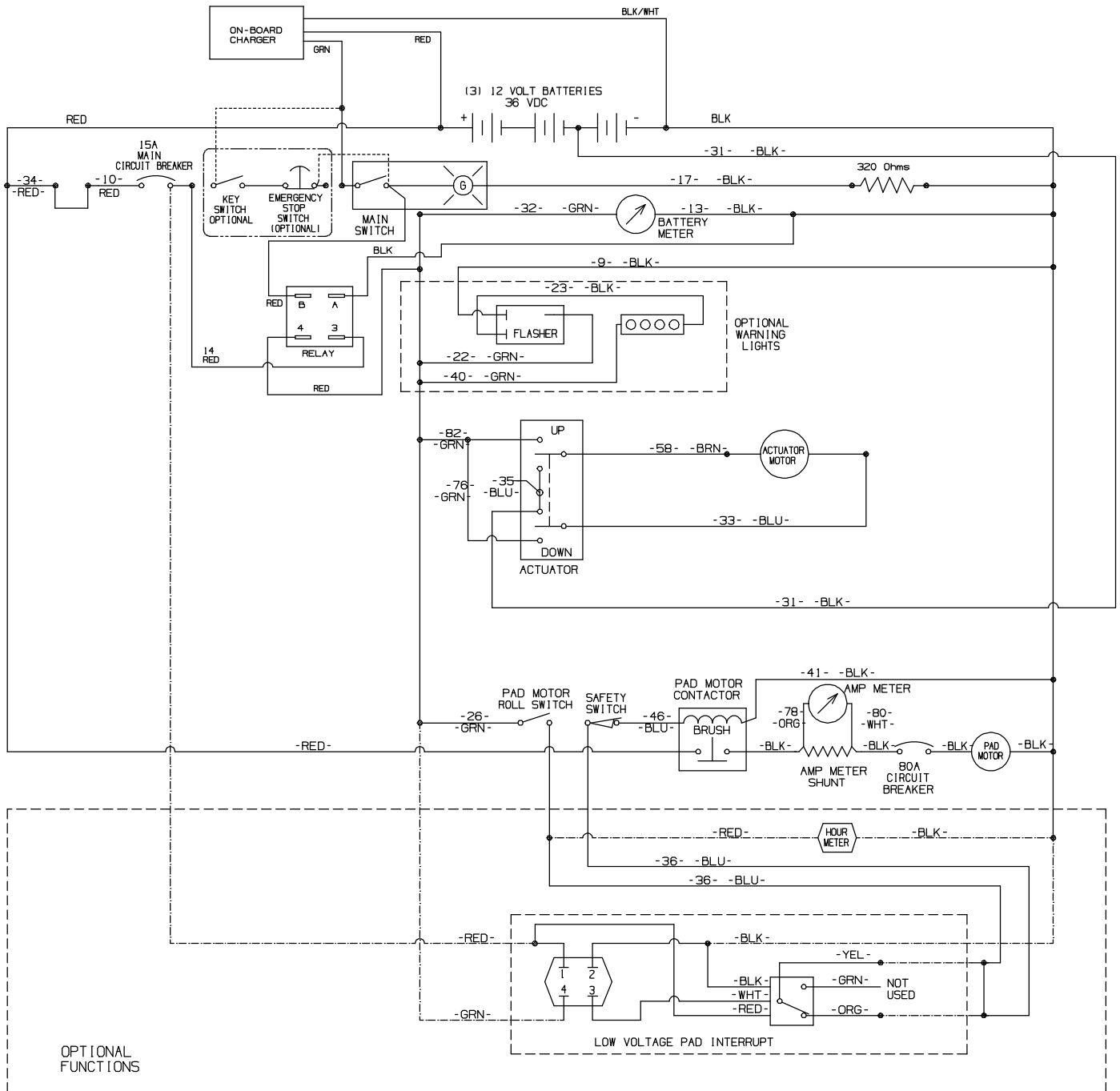

DWG #1042617

WIRING DIAGRAM 2510 MODEL WITHOUT ON-BOARD CHARGER

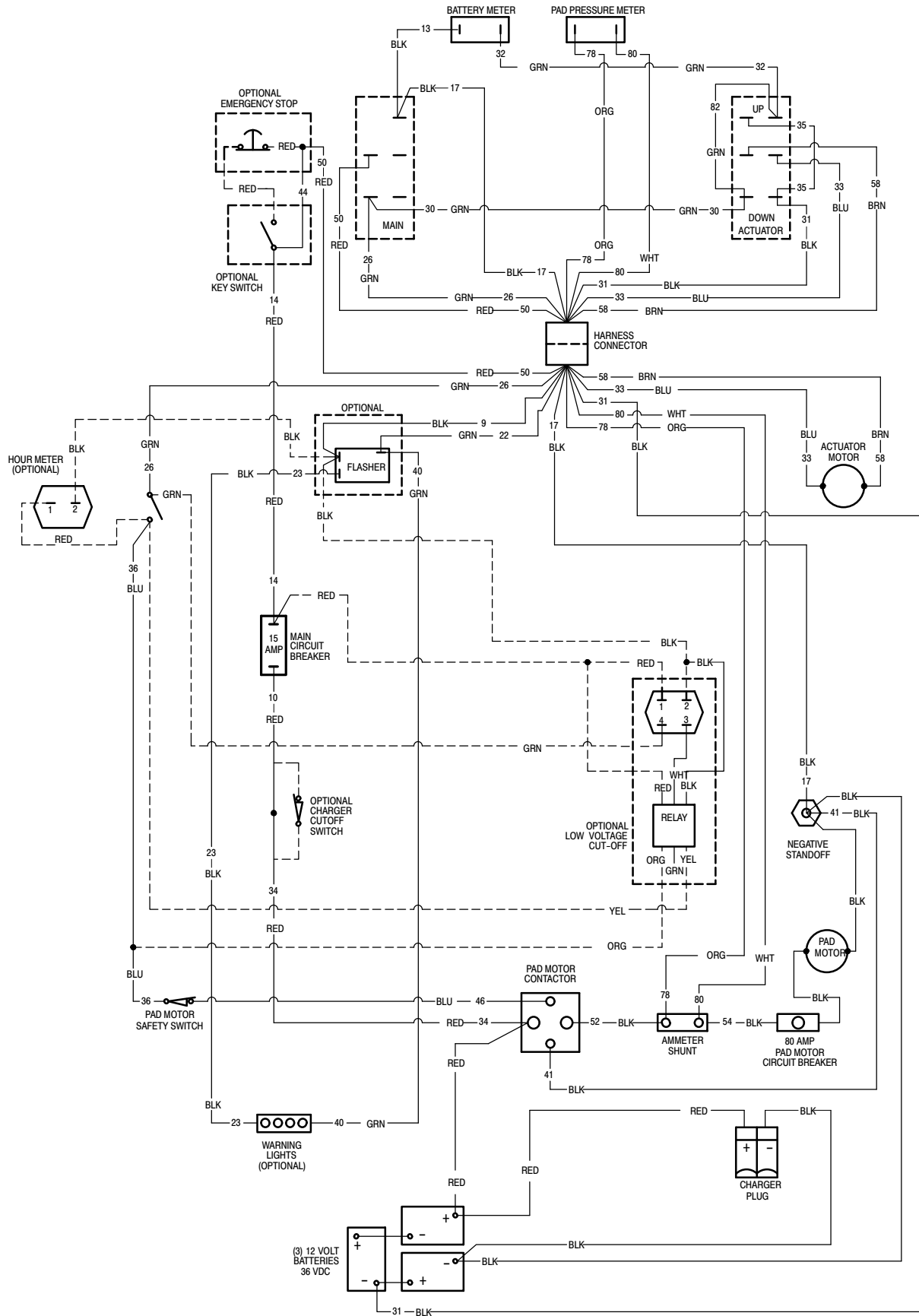



LADDER DIAGRAM 2510 MODEL WITHOUT ON-BOARD CHARGER

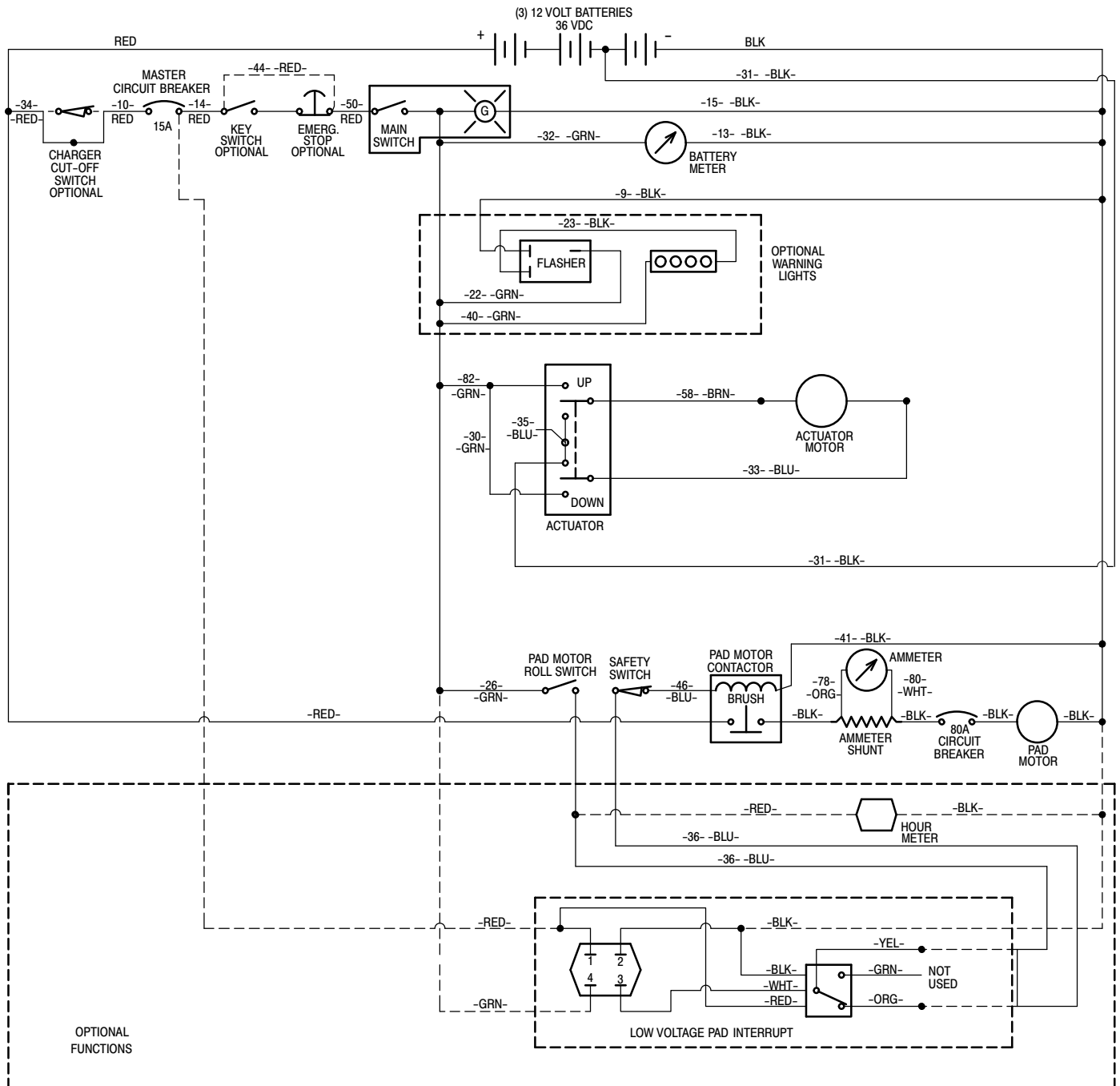

## WIRE HARNESS, MAIN, 2550

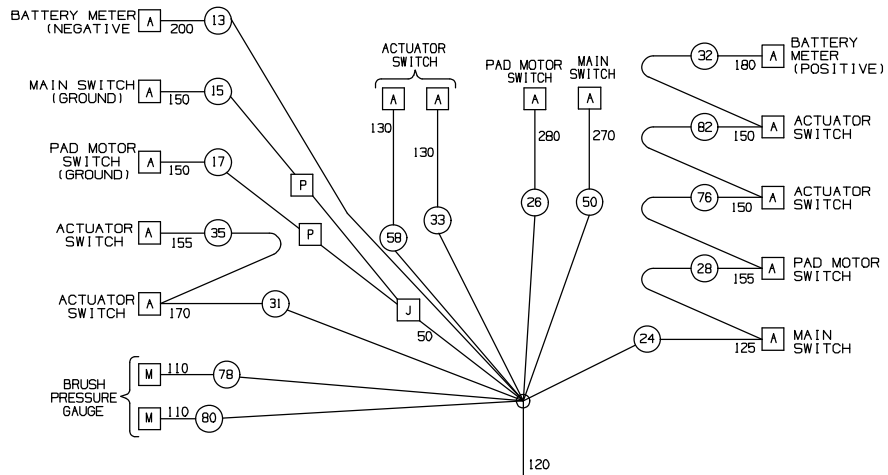

TERMINALS, CONNECTORS AND DIODE ASSEMBLIES	
A	FEMALE QUICK CONNECT 1/4", F/1
B	MALE QUICK CONNECT 1/4", F/1
C	RING TONGUE NO. 10, INSULATED BARREL
D	RING TONGUE 5/16", INSULATED BARREL
E	RING TONGUE 1/4", INSULATED BARREL
F	NOT USED
G	CHARGER PLUG CONTACT - SYSTEM MATERIAL HANDLING SY90461
H	PACKARD CONNECTOR, SERIES 480, P/N 12052613, WITH FEMALE TERMINAL 12052139, METRIC PACK INCLUDE PACKARD CABLE SEALS AND TPA
I	NOT USED
J	WIRE SPLICE
K	FEMALE QUICK CONNECT 1/4", UNINSULATED, SHRINK WRAPPED
L	NOT USED
M	FEMALE QUICK CONNECT 1/4", 90° FLAG, F/1
N	NOT USED
O	NOT USED
P	330 Ohms 1/2 WATT RESISTOR

PLUG (AMP)  
P/N 770021-1

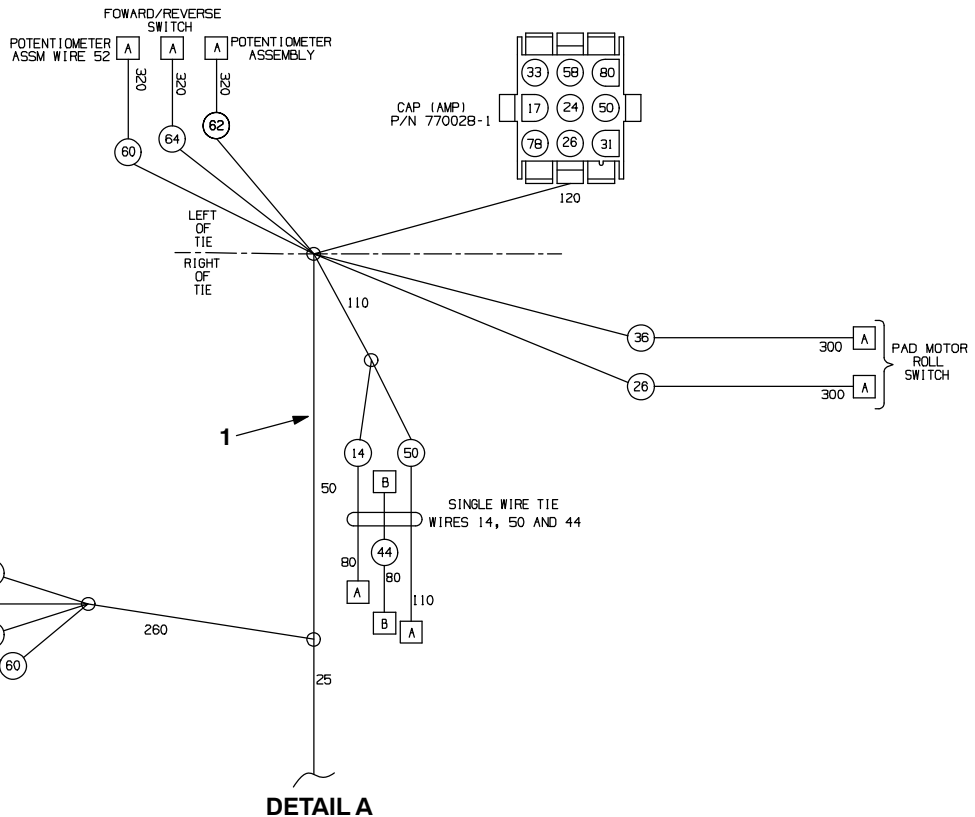
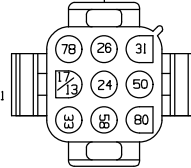

**DETAIL A**

WIRE HARNESS, MAIN, 2550 – CONT'D

WIRE NO.	AWG	COLOR	WIRE NO.	AWG	COLOR	WIRE NO.	AWG	COLOR
1	NOT USED		31	16	BLACK	61	NOT USED	
2	NOT USED		32	16	GREEN	62	22	ORANGE
3	14	BLACK	33	16	BLUE	63	NOT USED	
4	NOT USED		34	14	RED	64	22	BLUE
5	14	BLACK	35	16	BLACK	65	NOT USED	
6	14	RED	36	16	BLUE	66	22	GREEN
7	NOT USED		37	NOT USED		67	NOT USED	
8	NOT USED		38	NOT USED		68	NOT USED	
9	16	BLACK	39	NOT USED		69	NOT USED	
10	14	RED	40	16	GREEN	70	NOT USED	
11	NOT USED		41	16	BLACK	71	NOT USED	
12	14	ORANGE	42	NOT USED		72	NOT USED	
13	16	BLACK	43	NOT USED		73	NOT USED	
14	16	RED	44	16	RED	74	NOT USED	
15	16	BLACK	45	NOT USED		75	NOT USED	
16	NOT USED		46	16	BLUE	76	16	GREEN
17	16	BLACK	47	NOT USED		77	NOT USED	
18	NOT USED		48	NOT USED		78	10	ORANGE
19	NOT USED		49	NOT USED		79	NOT USED	
20	14	RED	50	16	RED	80	10	WHITE
21	14	BLACK	51	NOT USED		81	NOT USED	
22	16	GREEN	52	NOT USED		82	16	GREEN
23	16	BLACK	53	NOT USED				
24	16	GREEN	54	NOT USED				
25	NOT USED		55	NOT USED				
26	16	BLUE	56	NOT USED				
27	NOT USED		57	NOT USED				
28	16	GREEN	58	16	BROWN			
29	NOT USED		59	NOT USED				
30	NOT USED		60	22	WHITE			

DETAIL A

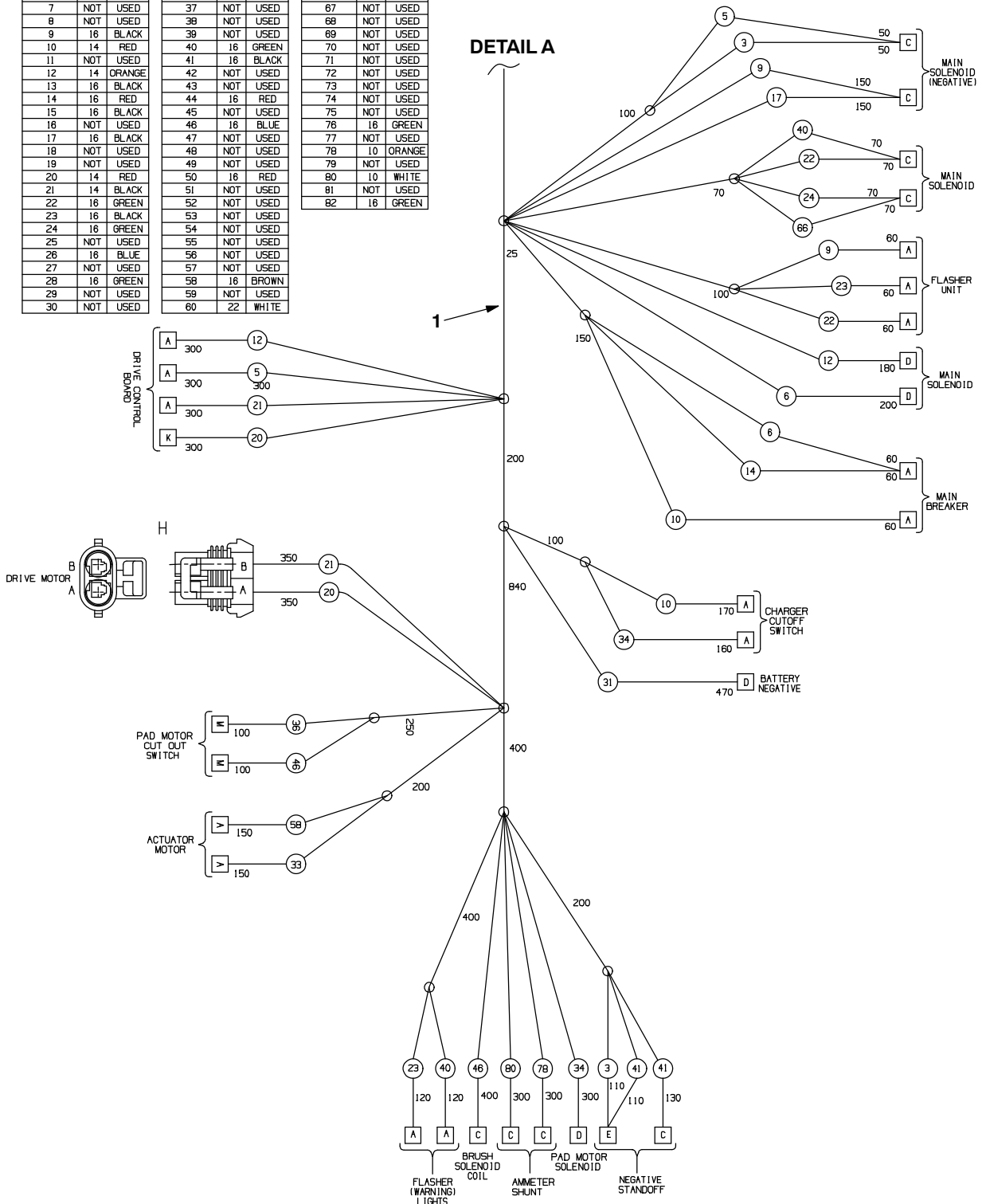

Ref.	Part No.	Serial Number	Description	Qty.
1	613086	(0000000-	) Harness, Main, Drive [2550]	1

## WIRE HARNESS, MAIN, 2510

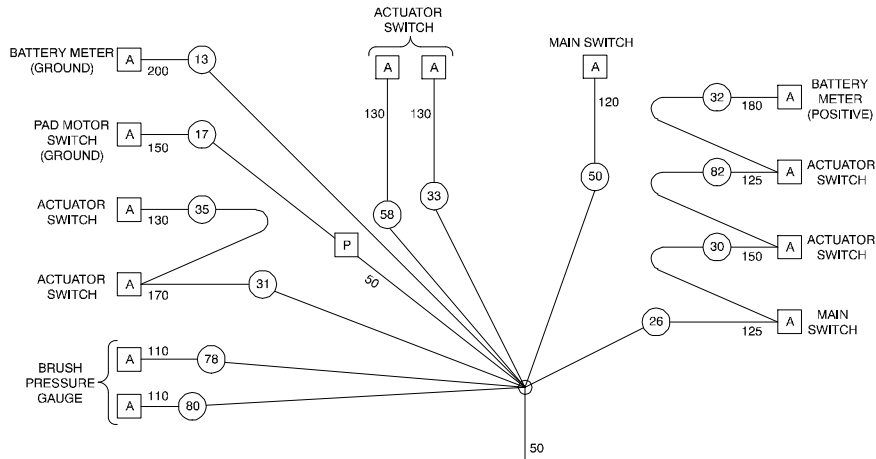

### WIRE LIST

WIRE NO.	AWG	COLOR	WIRE NO.	AWG	COLOR	WIRE NO.	AWG	COLOR
1	NOT	USED	31	16	BLACK	61	NOT	USED
2	NOT	USED	32	16	GREEN	62	NOT	USED
3	NOT	USED	33	16	BLUE	63	NOT	USED
4	NOT	USED	34	14	RED	64	NOT	USED
5	NOT	USED	35	16	BLACK	65	NOT	USED
6	NOT	USED	36	16	BLUE	66	NOT	USED
7	NOT	USED	37	NOT	USED	67	NOT	USED
8	16	RED	38	NOT	USED	68	NOT	USED
9	16	BLACK	39	NOT	USED	69	NOT	USED
10	16	RED	40	16	GREEN	70	NOT	USED
11	NOT	USED	41	16	BLACK	71	NOT	USED
12	NOT	USED	42	NOT	USED	72	NOT	USED
13	16	BLACK	43	NOT	USED	73	NOT	USED
14	16	RED	44	16	RED	74	NOT	USED
15	NOT	USED	45	NOT	USED	75	NOT	USED
16	NOT	USED	46	16	BLUE	76	NOT	USED
17	16	BLACK	47	NOT	USED	77	NOT	USED
18	NOT	USED	48	NOT	USED	78	10	ORANGE
19	NOT	USED	49	NOT	USED	79	NOT	USED
20	NOT	USED	50	16	RED	80	10	WHITE
21	NOT	USED	51	NOT	USED	81	NOT	USED
22	16	GREEN	52	NOT	USED	82	16	GREEN
23	16	BLACK	53	NOT	USED			
24	NOT	USED	54	NOT	USED			
25	NOT	USED	55	NOT	USED			
26	16	GREEN	56	NOT	USED			
27	NOT	USED	57	NOT	USED			
28	NOT	USED	58	16	BROWN			
29	NOT	USED	59	NOT	USED			
30	16	GREEN	60	NOT	USED			

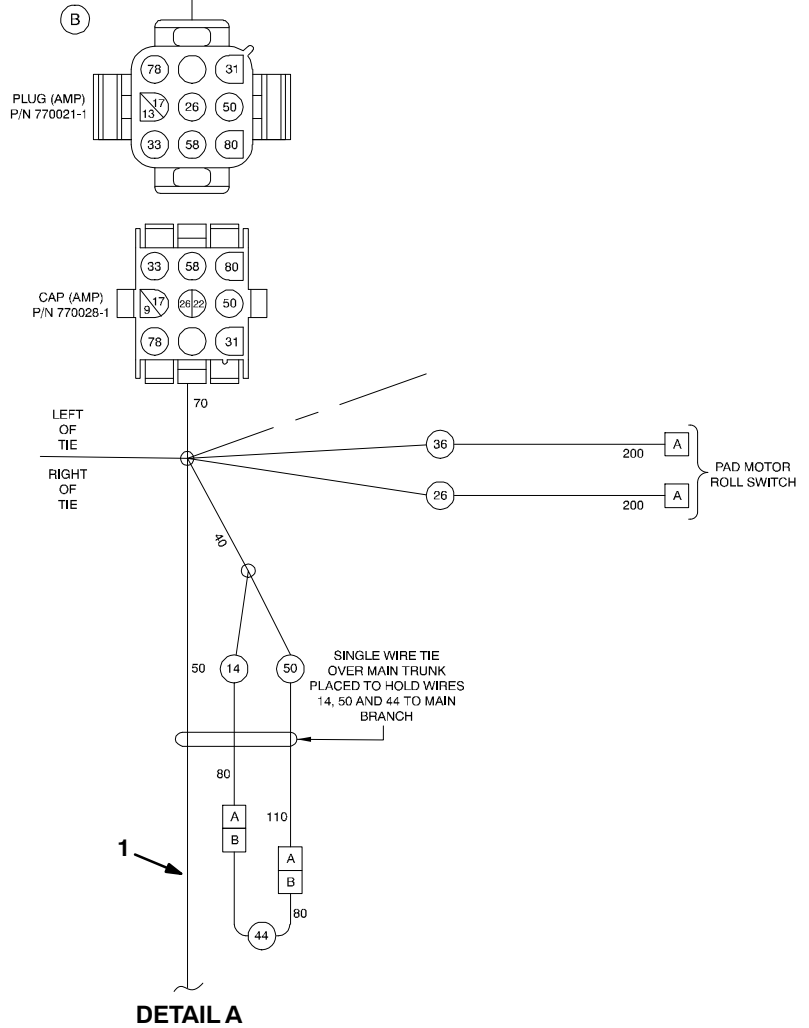

DETAIL A

WIRE HARNESS, MAIN, 2510 - CONT'D

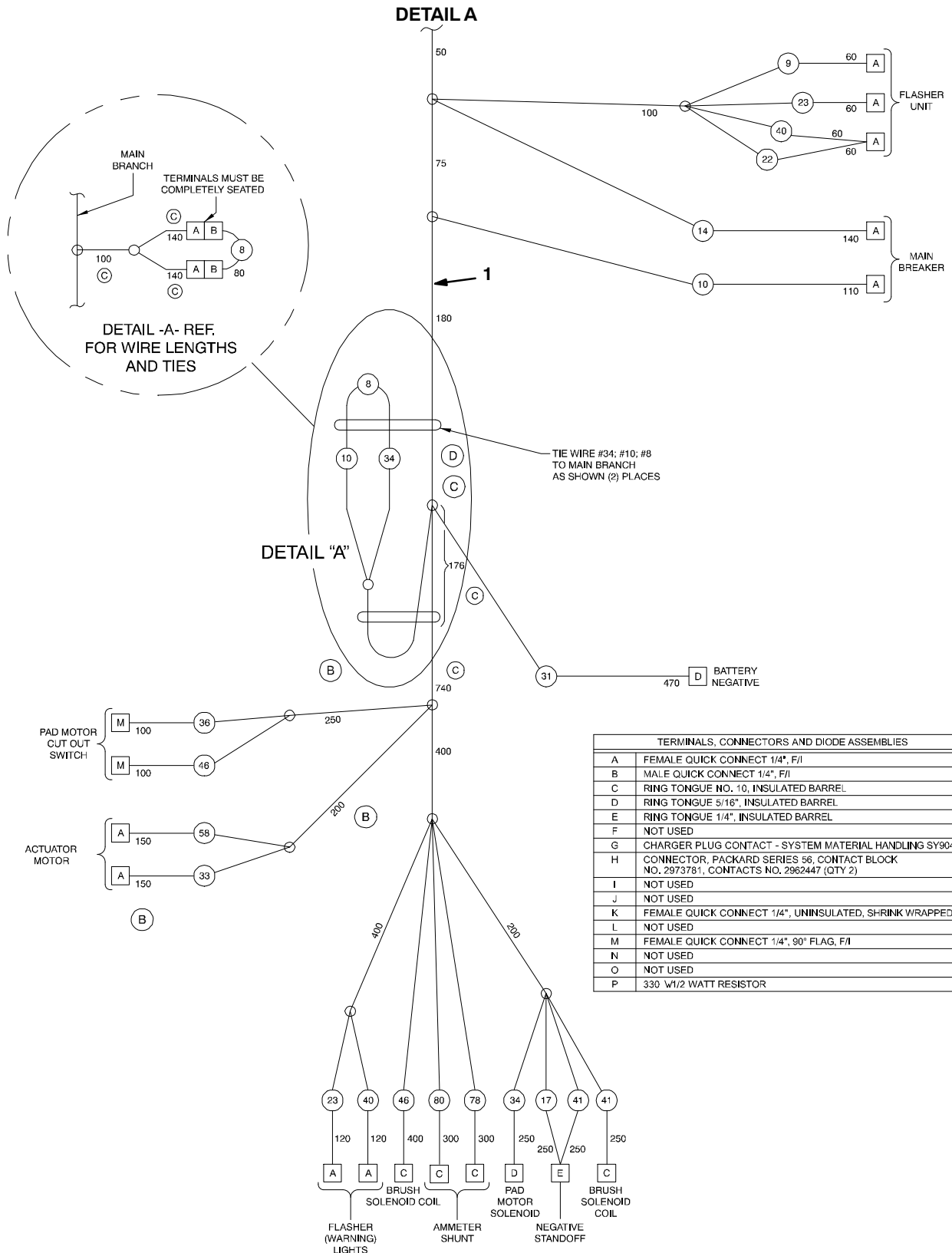

Ref.	Part No.	Serial Number	Description	Qty.
1	606539	(00000000- )	Harness, Main, Push [2510]	1

**HOUR METER, EMERGENCY STOP AND KEYSWITCH KITS**

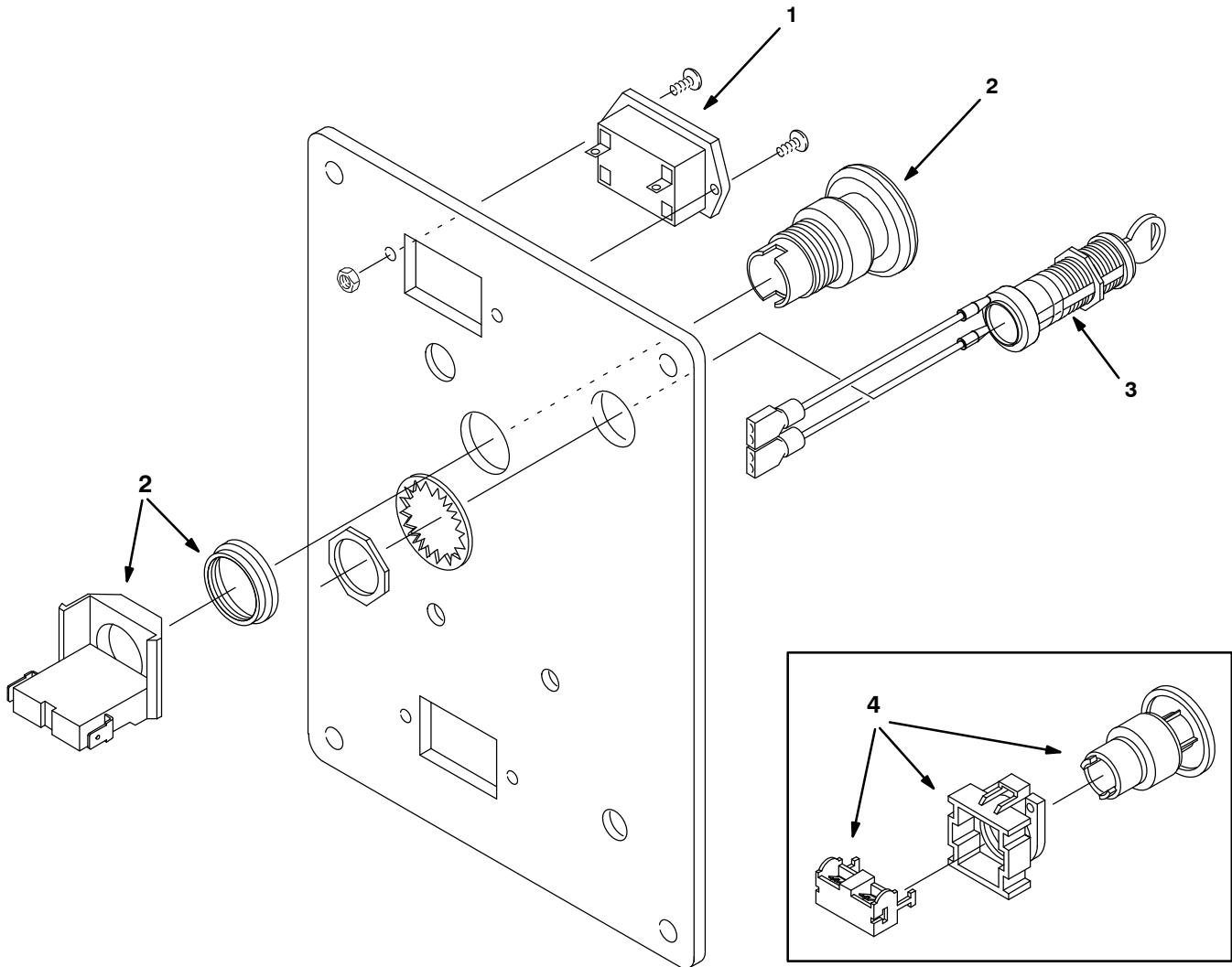

Ref.	Part No.	Serial Number	Description	Qty.
▽	1	604501	(00000000- ) ● Gauge Kit, Hourmeter [Spdgleams]	1
▲		1010555	(00000000- ) ● Gauge, Hourmeter, 14-48vdc, Lcd, Rt	1
▲		603081	(00000000- ) Wire, 18ga 12.0l Red .25pb /.19qf, Tt	1
▲		604960	(00000000- ) Wire, 18ga 09.0l Blk .19pb /.25qf, Tt	1
▲		603080	(00000000- ) Wire, 18ga 08.0l Blk .19qf /.19ring, Tt	1
▲		604643	(00000000- ) Wire, 18ga 09.0l Blk .19qf /.25qm	1
▽	2	612971	(00000000- ) ● E-Stop Kit [Spdgleam Plus R/S]	1
▲		1011735	(00000000- ) ● Switch, Safety, Shutoff	1
▲		602996	(00000000- ) Wire, 16ga 05.0l Red .25qf /.25qf	1
▲		602997	(00000000- ) Wire, 16ga 05.0l Red .25qf /.25qm	1
▽	3	612973	(00000000- ) ● Switch Kit, Key [Spdgleam R/S]	1
▲▽		607475	(00000000- ) ● Switch, 12a [Keylock]	1
▲▲		607821	(00000000- ) ● Key, Stl, Replmt	1
▲		601222	(00000000- ) Wire, 14ga 13.0l Red .25qf /.25qf	2
	4	N/A	(00000000- ) (Replaced by 612971)	1

▽ ASSEMBLY

▲ INCLUDED IN ASSEMBLY

● RECOMMENDED STOCK ITEMS

LOW VOLT INTERRUPT KIT

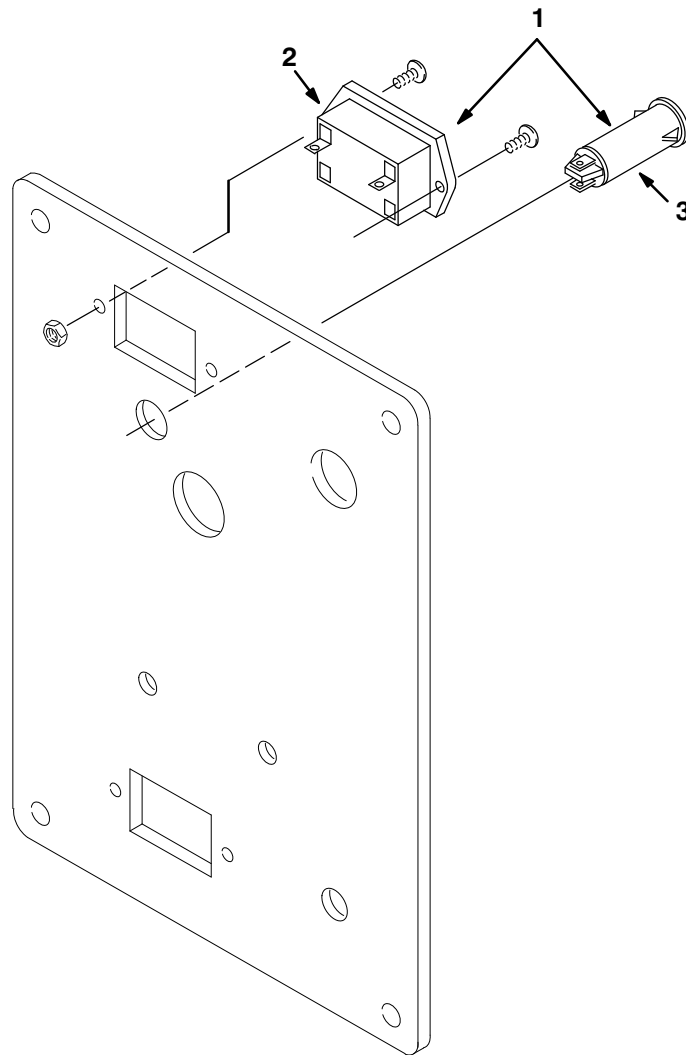

Ref.	Part No.	Serial Number	Description	Qty.
▽	1	604642	(00000000- ) Interrupter Kit, Low Voltage [36v Batt]	1
▲	2	600832	(00000000- ) Gauge, Discharge, Battery, 36vdc [Digit]	1
▲	3	600831	(00000000- ) Lamp, Red, Blk Body, 36vdc W/ Push Nut	1
▲		604641	(00000000- ) Relay Kit, Low Voltage	1
▲		604643	(00000000- ) Wire, 18ga 09.0l Blk .19qf /.25qm	1
▲		604645	(00000000- ) Wire, 18ga 11.0l Green .25pb /.19qf[Mtw]	1
▲		603078	(00000000- ) Wire, 18ga 09.0l Green .19qf /.19ring	1
▲		603080	(00000000- ) Wire, 18ga 08.0l Blk .19qf /.19ring, Tt	1
▲		603081	(00000000- ) Wire, 18ga 12.0l Red .25pb /.19qf, Tt	1
▲		604960	(00000000- ) Wire, 18ga 09.0l Blk .19pb /.25qf, Tt	1
▲		130193	(00000000- ) Terminal Ring #10 22-18 Rd	1
▲		281004001	(00000000- ) Terminal, Fem .25 22-18ga Red, F-Ins	1
▲		130040	(00000000- ) Tie, Cable, Nyl, 06.0l .12w	1
▲		610713	(00000000- ) Label, Low Voltage [Textless]	1
▲		130183	(00000000- ) Terminal, Tt, .25fem, 18-14ga	1
▲		130133	(00000000- ) Terminal, Mal, .25 22-18ga Red, F-Ins	1

▽ ASSEMBLY

▲ INCLUDED IN ASSEMBLY

PARKING BRAKE KIT

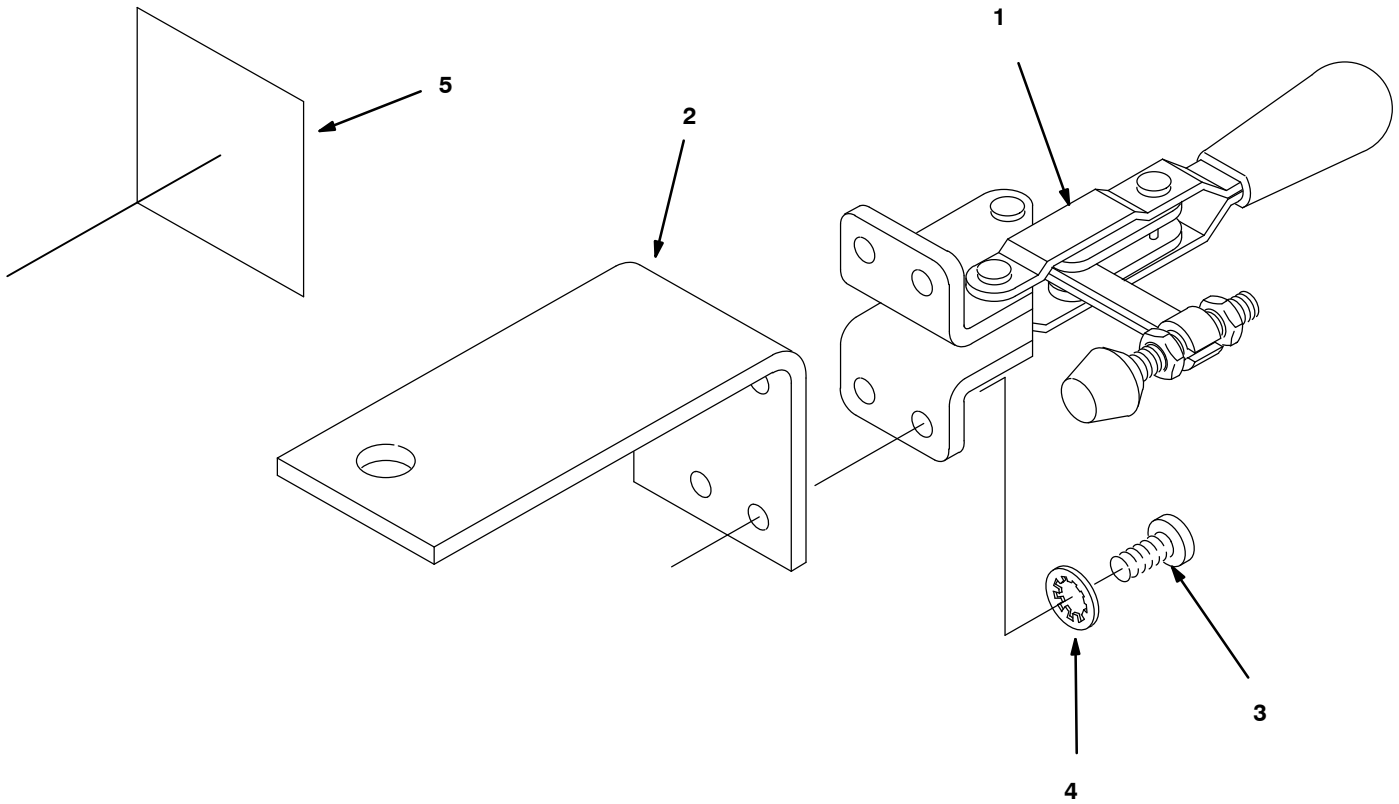

Ref.	Part No.	Serial Number	Description	Qty.
▽	604502	(00000000-	● Brake Kit, Parking	1
▲	1 600634	(00000000-	) Clamp, Brake, Parking	1
▲	2 603122	(00000000-	) Bracket, Brake [2550]	1
▲	3 140887	(00000000-	) Screw, Pan, 10-24 X 0.38, Ss	4
▲	4 07514	(00000000-	) Washer, Lock, Int, 10, Ss	4
▲	5 600624	(00000000-	) Label, Parking Brake, Symbol [Tnv]	1

▽ ASSEMBLY

▲ INCLUDED IN ASSEMBLY

● RECOMMENDED STOCK ITEMS



FLASHING LIGHT KIT

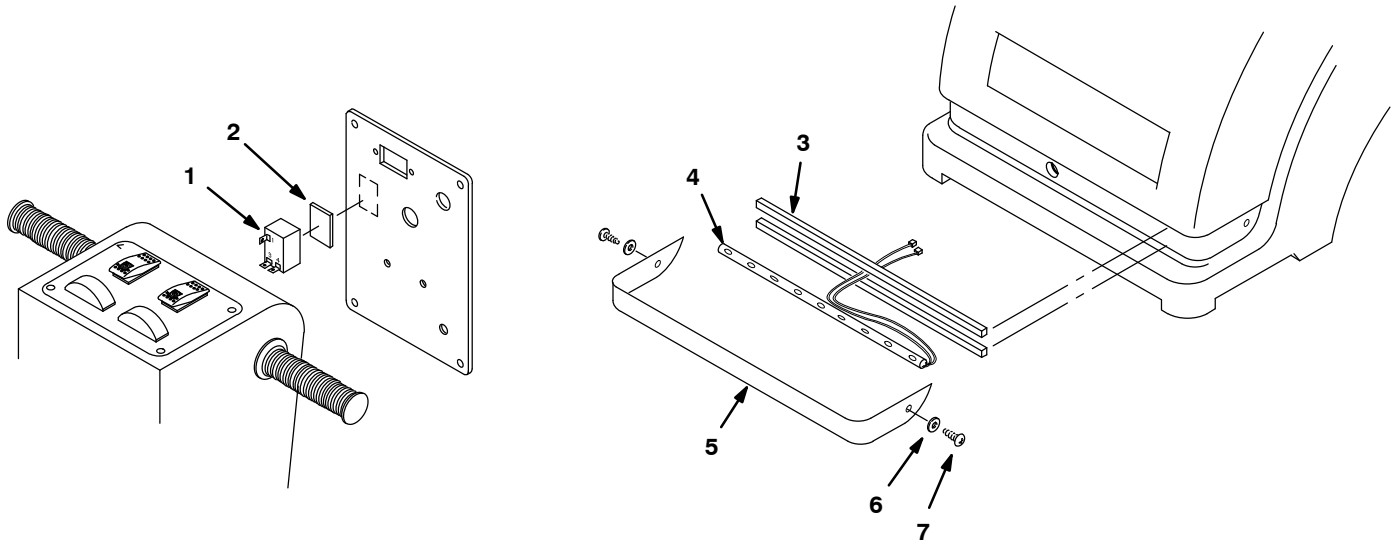

Ref.	Part No.	Serial Number	Description	Qty.	
▽	604500	(00000000-	)● Light Kit, Flsh	1	
▲	1	603839	(00000000-	)● Flasher, 36vdc	1
▲	2	606243	(00000000-	) Tape, Foam, Acrylic, 1.0w X 12.0l	1
▲	3	606242	(00000000-	) Seal, Rbr, Clsd, .50, .50w 30.0l Adh	1
▲	4	603440	(00000000-	)● Light, Safety, 36vdc	1
▲	5	612765	(00000000-	) Sheild, Light	1
▲	6	578186000	(00000000-	) Washer, Flat, 0.18b 0.46d .04, Pl, M4	2
▲	7	200070340	(00000000-	) Screw, Pan, Phl, M4 X 0.70 X 8, Pl	2

▽ ASSEMBLY

▲ INCLUDED IN ASSEMBLY

● RECOMMENDED STOCK ITEMS

AIR INLET GROUP (JAPAN MARKET)

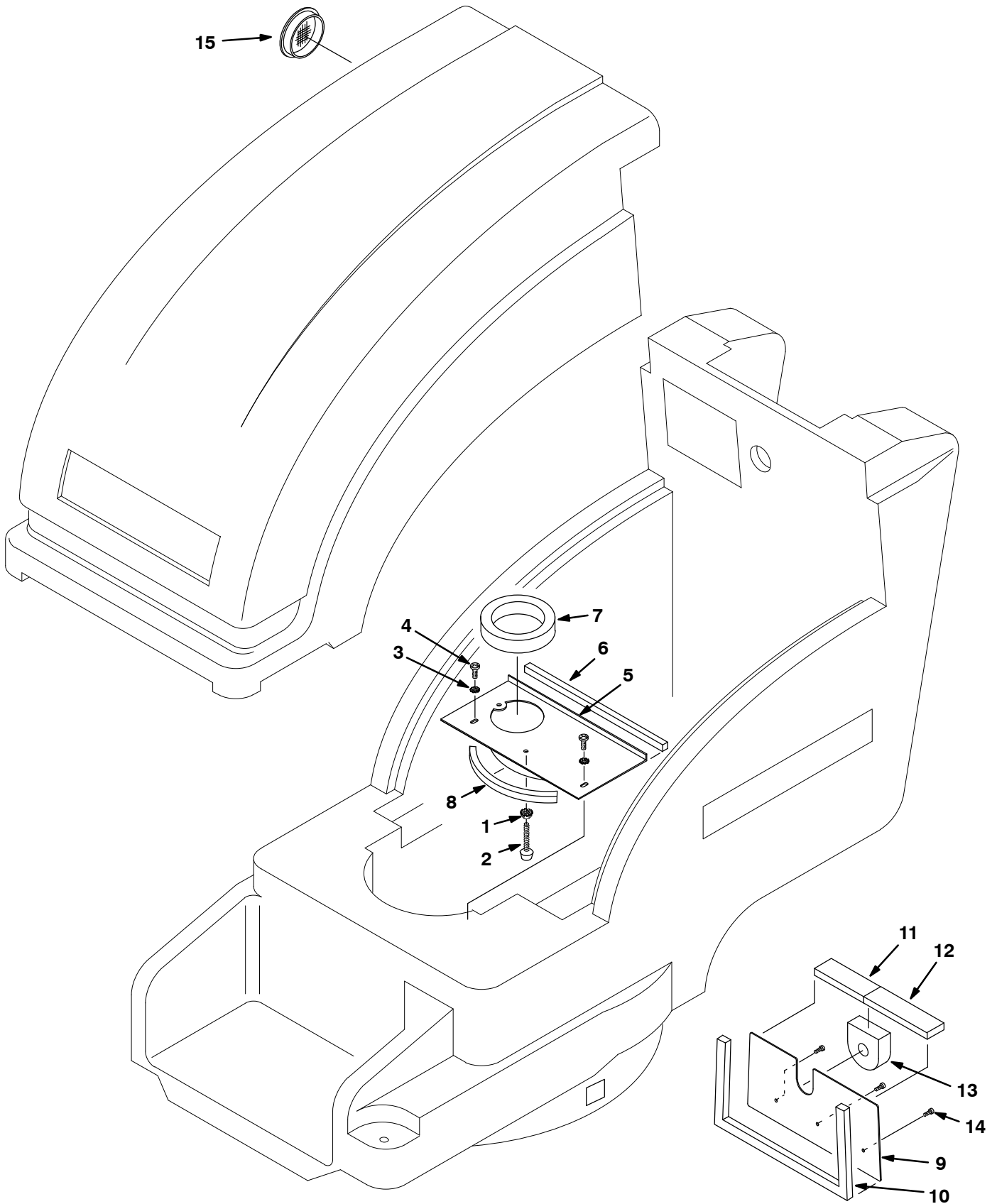

**AIR INLET GROUP**

Ref.	Part No.	Serial Number	Description	Qty.
1	140524	(00000000-	) Nut, Hex, Lock, .25-20, Kep	1
2	606684	(00000000-	) Stop, Motor	1
3	140016	(00000000-	) Washer, Lock, Split, 0.25, Ss	2
4	363503	(00000000-	) Screw M6x1.0x12 Panphl Ss	2
5	611472	(00000000-	) Plate, Front, Seal	1
6	611492	(00000000-	) Seal, .50, .50w 12.00l, Adh	1
7	611486	(00000000-	)● Gasket, 1.00, 3.50id 4.75od, Adh	1
8	611361	(00000000-	) Seal, .50, .50w 07.00l, Adh	1
9	612156	(00000000-	) Plate Air Intake Seperator	1
10	611357	(00000000-	) Gasket, Plt, Air Seperator, .50th, Adh	1
11	611358	(00000000-	) Seal, .50, 01.50w 04.25l, Adh	1
12	611359	(00000000-	) Seal, .50, 01.50w 05.50l, Adh	1
13	612159	(00000000-	) Gasket Actuator	1
14	140825	(00000000-	) Screw, Pan, Phl, 06 X 0.50, Fmg/Ab, Blk	3
15	611473	(00000000-	)● Screen, Inlet, Air	1

● RECOMMENDED STOCK ITEMS