



1550

Automatic Carpet Extractor

Model No.:
607877
608934 - PAC
610694 - PAC CAN.

Operator and Parts Manual

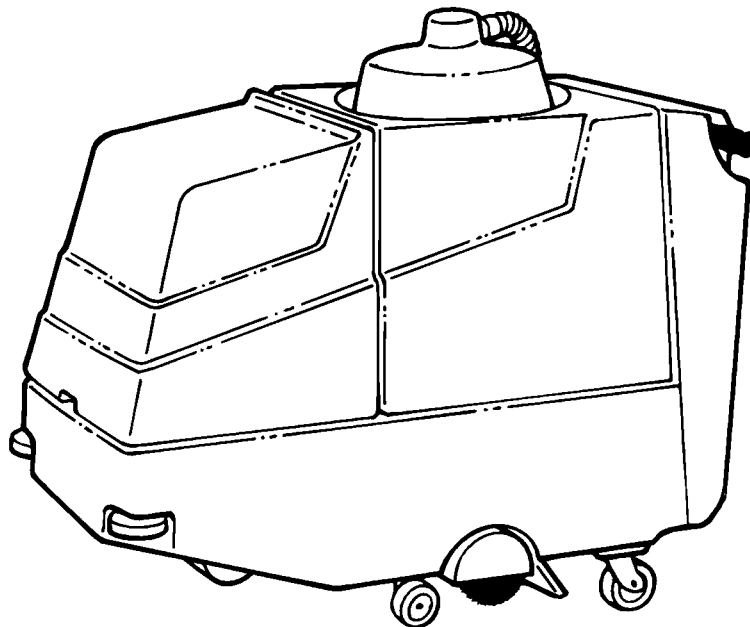

TENNANT COMPANY
701 NORTH LILAC DRIVE
MINNEAPOLIS, MN 55422

MAILING ADDRESS:
TENNANT COMPANY
P.O. BOX 1452
MINNEAPOLIS, MN 55440-1452

CUSTOMER SERVICE:
1-800-982-7658
1-763-513-2850

FAX: 1-800-678-4240
1-763-513-2142

TECHNICAL SUPPORT:
1-800-522-7839 EXT. 5356

607758
Rev. 01 (09-03)

ELECTRICAL DIAGRAMS

WIRE DIAGRAM

NOTE: METERS AND ROCKER SWITCHES SHOWN AS VIEWED FROM FRONT OF SWITCH PANEL

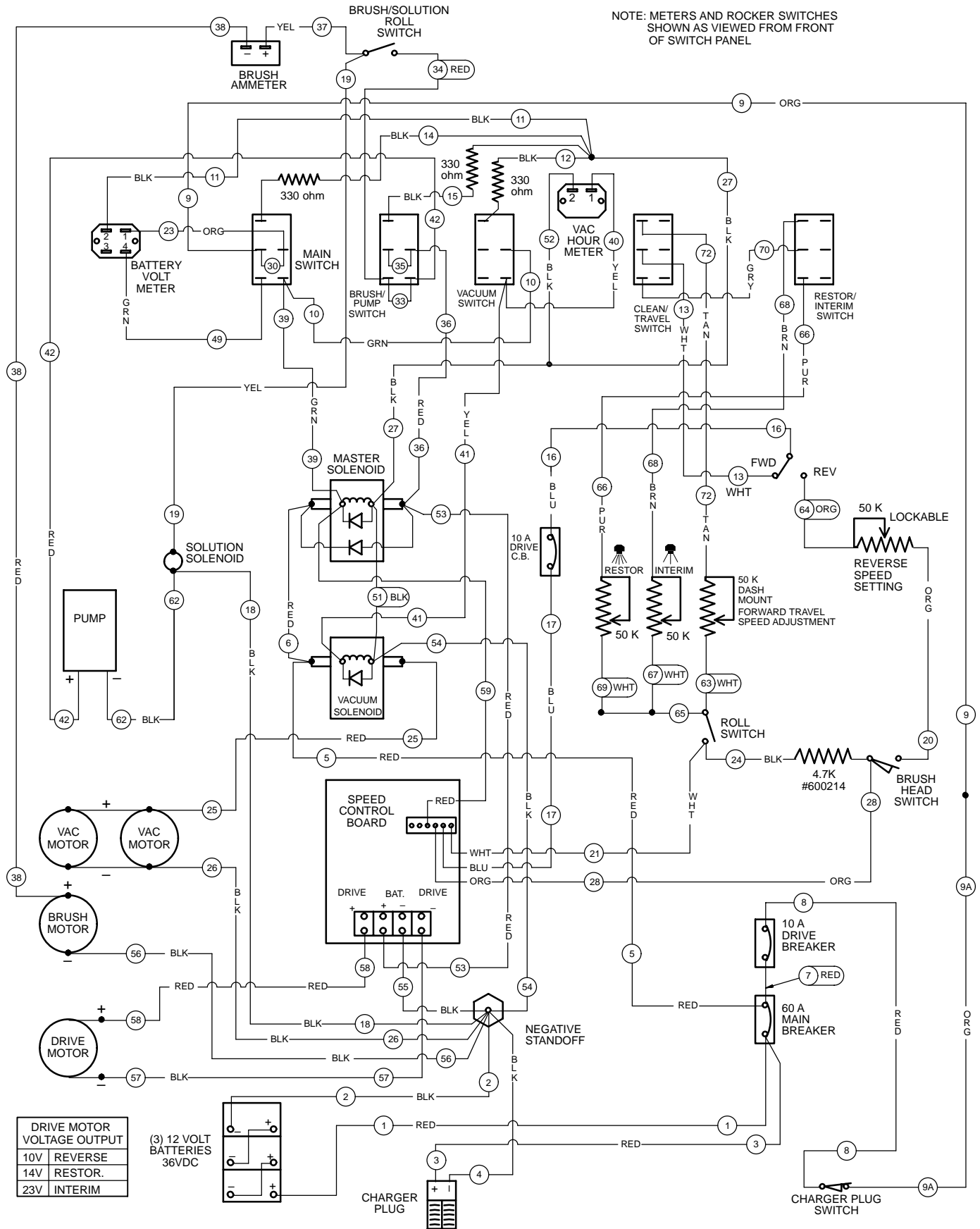

DRIVE MOTOR VOLTAGE OUTPUT	
10V	REVERSE
14V	RESTOR.
23V	INTERIM

(3) 12 VOLT BATTERIES 36VDC

LADDER DIAGRAM

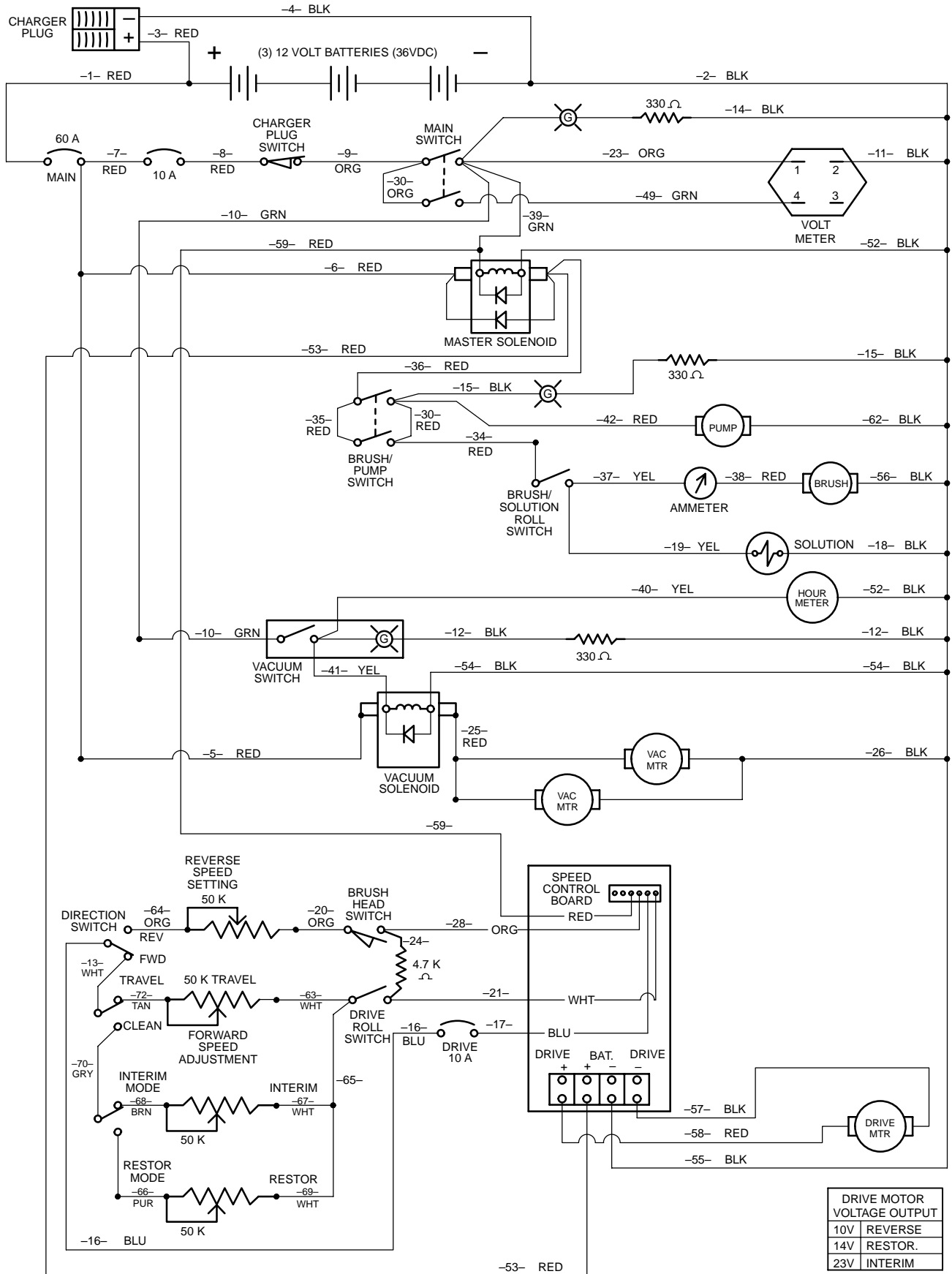

UPPER HOUSING GROUP

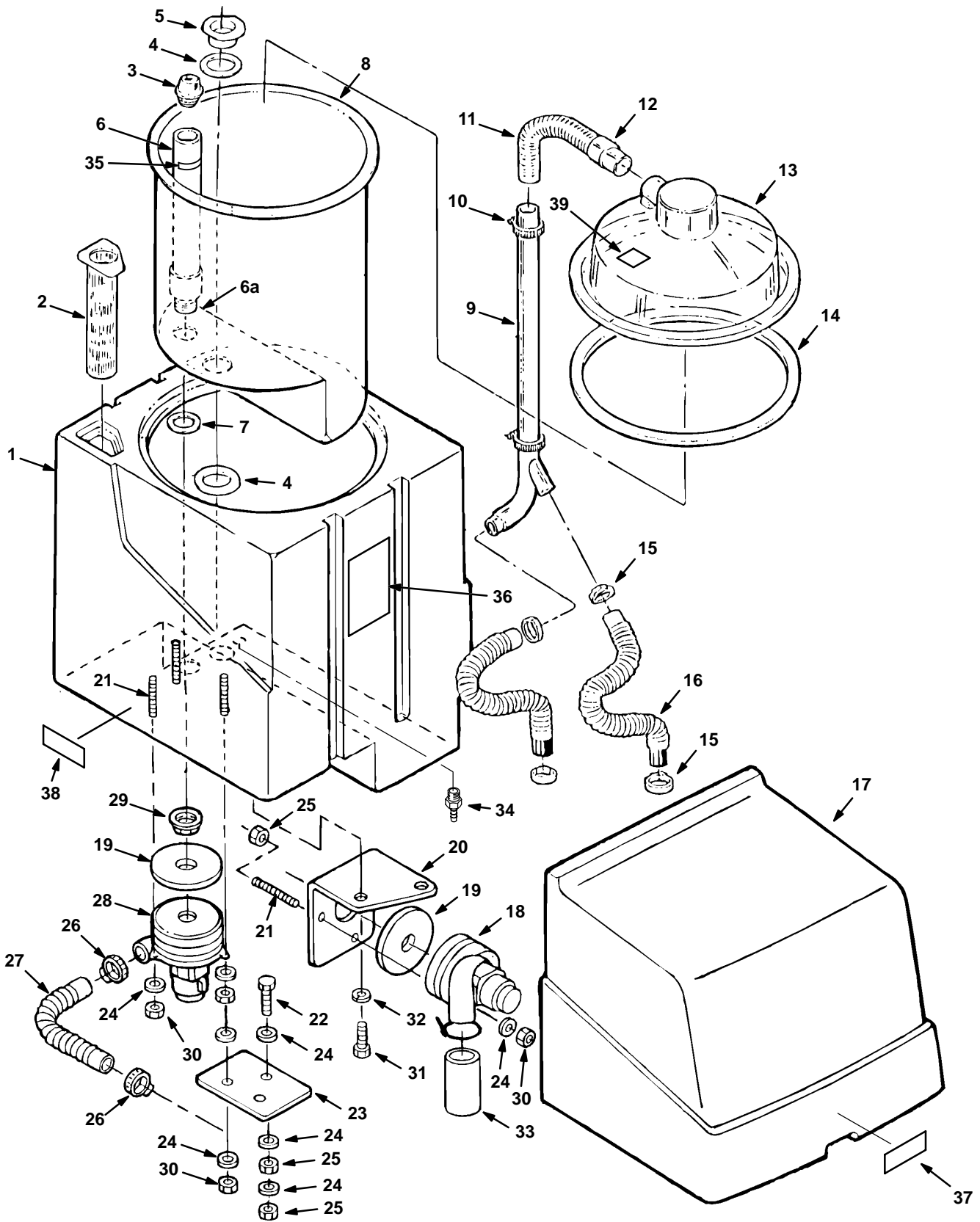

UPPER HOUSING GROUP

REF	PART #	DESCRIPTION	QTY.
1	607807	TANK, SOLUTION, OFF WHITE	1
2	180610	●FILTER, SCREEN, 20 MESH	1
3	180612	●FILTER, SCREEN, 20 MESH	1
4	150303	●GASKET, INLET FLANGE (2 PC.)	1
5	603094	FITTING, INLET FLANGE W/FLATS	1
6	701225	ASSEMBLY, TUBE, VACUUM STANDPIPE	1
6a	606088	FITTING, 1-1/2 NIPPLE	1
7	101714	●GASKET, WASTE AIR CHAMBER	1
8	607809	TANK, RECOVERY, OFF WHITE	1
9	240178	TUBE, INLET	1
10	140308	CLAMP, HOSE 1-5/16 TO 2-1/4	2
11	160846	●HOSE, 1-1/2X10-1/4	1
12	160430	●CUFF, HOSE 1-1/2X1-1/2	1
13	100111	DOME, VACUUM	1
14	100032	●GASKET, DOME & TANK	1
15	140322	CLAMP, VAC HOSE PICKUP TOOL	4
16	160456	●HOSE, VACUUM, PICKUP TOOL 16"	2
17	607813	COVER, HOOD, OFF WHITE	1
▽ 18	611071000	●MOTOR, VAC 5.7D 3-STAGE, 36V	1
▲	190162	●BRUSH, CARBON	2
19	626092	●GASKET, VAC MOTOR	2

REF	PART #	DESCRIPTION	QTY.
20	230957	PLATE, VAC MOUNT	1
21	140227	SCREW, STUD, 1/4-20X5	6
22	140208	SCREW, 1/4-20X1 HXHDCP	2
23	613909	PLATE, CONNECTOR	1
24	140000	WASHER, 1/4 FLAT	12
25	140524	NUT, 1/4-20 KEP	5
26	140308	CLAMP, HOSE 1-5/16 TO 2-1/4	2
27	160631	●HOSE, VACUUM, 1-1/2X16"	1
▽ 28	398521	●MOTOR, VAC 5.7D, 3-STAGE, 36V	1
▲	398513	●BRUSH, CARBON (SET OF 2)	1
29	210240	NUT, 1-1/2 FLANGED	1
30	41169	NUT, 1/4-20 NYLCK	7
31	140259	SCREW, 1/4-20X5/8 HEXHD	2
32	140016	WASHER, 1/4 LOCK	2
33	600009	MUFFLER, EXHAUST	1
34	150524	FITTING, 1/8M X 1/8H	1
35	120247	DECAL, "FULL"	1
36	602637	LABEL, BATTERY CHARGE	1
37	607979	LABEL, TENNANT	1
38	608153	LABEL, "1550"	2
39	120246	LABEL, DO NOT ALLOW FOAM	1

▽ ASSEMBLY

▲ INCLUDED IN ASSEMBLY

● RECOMMENDED STOCK ITEMS

MAIN CHASSIS GROUP

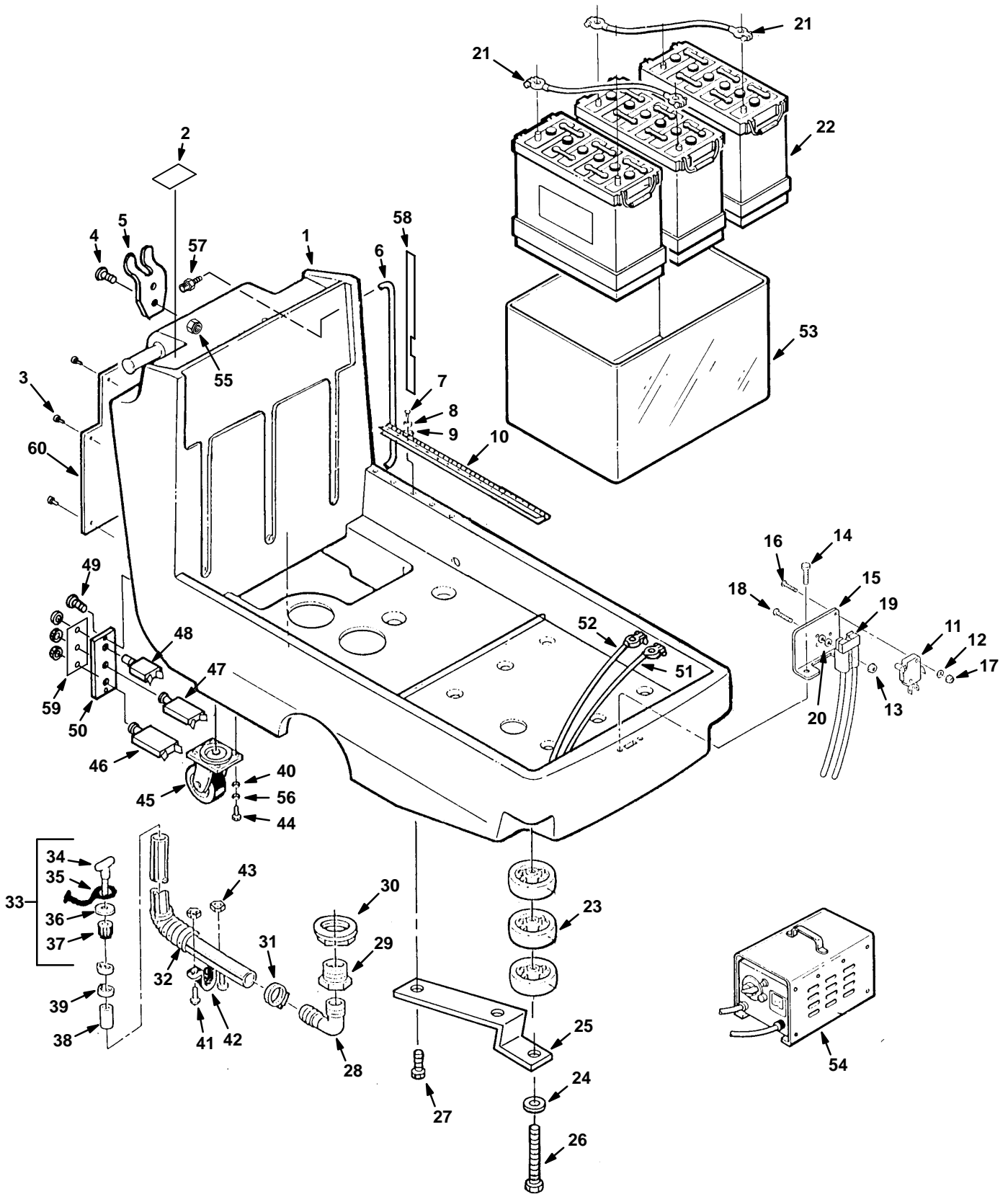

MAIN CHASSIS GROUP

REF	PART #	DESCRIPTION	QTY.
▽ 1	614123	ASM, CHASSIS W/ LABEL, TEAL	1
▲ 2	613288	LABEL, WARNING	1
3	240204	●KNOB, ROUND	5
4	140825	SCREW, #6X1/2	2
5	611978	BRACKET, DRAIN HOSE	1
6	613458	HOSE, 1/8ID CLR VYL (4.5 FT)	1
7	01696	SCREW, 1/4-20X1/2 HEXHD	9
8	140000	WASHER, 1/4 FLAT	9
9	140016	WASHER, 1/4 LOCK	9
10	140440	HINGE, SOLUTION TANK	1
11	600437	●SWITCH, SNAP ACTION	1
12	200301012	WASHER, M3 FLAT	2
13	140539	NUT, #6-32 KEP	2
14	140852	SCREW, #12X3/4 SHTMTL	2
15	231040.BK	PLATE, PLUG MOUNT	1
16	200070266	SCREW, M3X.5X16 PAN HD	2
17	579211	NUT, M3 LOCK	2
18	140829	SCREW, #6-32X1 PANPHL	2
19	130155	●CONNECTOR, GRAY 50A	1
20	140026	WASHER, #6 FLAT	4
21	130367	CABLE, BATTERY 15" BLK 6 GA	2
22	600394	BATTERY, 12V, 215AH	3
23	103026	WHEEL, BUMPER	6
24	140008	WASHER, 1/2 FLAT	2
25	230246.BK	BRACKET, BUMPER WHEEL (LEFT)	1
	230247.BK	BRACKET, BUMPER WHEEL (RIGHT)	1
26	140562	SCREW, 1/2-13X6-1/2 HXHDCP	2
27	140563	SCREW, 5/16X1 LAG	4
28	230832	FITTING, 1-1/4M X 1-1/4H 90°	1
29	230833	FITTING, ADAPTER, 1-1/4F X 1-1/2M	1

REF	PART #	DESCRIPTION	QTY.
30	603094	INLET FLANGE, W/FLATS	1
31	140307	CLAMP, 3/4 TO 1-3/4	1
32	160415	●HOSE DRAIN	1
▽ 33	701061	●ASSEMBLY, PLUG	1
▲ 34	230831	●KNOB, DRAIN HOSE	1
▲ 35	230882	●STRAP, PLUG	1
▲ 36	140056	WASHER, 3/8 FENDER	1
▲ 37	140955	FITTING, PLUG, DRAIN HOSE	1
38	140921	SLEEVE, DRAIN HOSE	1
39	140072	CLAMP, HOSE 1-9/16"	2
40	140036	WASHER, 3/8 FLAT	8
41	140823	SCREW, #10-24X5/8 TRSPHL	2
42	230109.BK	BRACKET, HOSE SUPPORT	1
43	140552	NUT, #10-24 NYLK	2
44	02994	SCREW, 3/8-16X3/4 HEXHD	8
45	103002	●CASTER, 4" SWIVEL	2
46	130755	●CIRCUIT BREAKER, DRIVE, 10A	1
47	130739	●CIRCUIT BREAKER, MAIN, 60A	1
48	130737	●CIRCUIT BREAKER, BRUSH, 10A	1
49	140887	SCREW, #10-24X3/8 PANPHL	2
50	231058.BK	PLATE, BREAKER MOUNT	1
51	600969	●CABLE, BATTERY, RED	1
52	600970	●CABLE, BATTERY, BLACK	1
53	100709	BOX, BATTERY	1
54	469760868	CHARGER, BATTERY (120V)	1
	600599	CHARGER, BATTERY (230V)	1
55	140539	NUT, #6-32 KEP	2
56	140017	WASHER, 3/8 LOCK	8
57	150524	FITTING, 1/8M X 1/8H	1
58	120243	DECAL, GALLON MARKER	1
59	120245	DECAL, CIRCUIT BREAKER	1
60	231023.BK	PANEL, REAR	1

▽ ASSEMBLY

▲ INCLUDED IN ASSEMBLY

● RECOMMENDED STOCK ITEMS

CONTROL CONSOLE GROUP

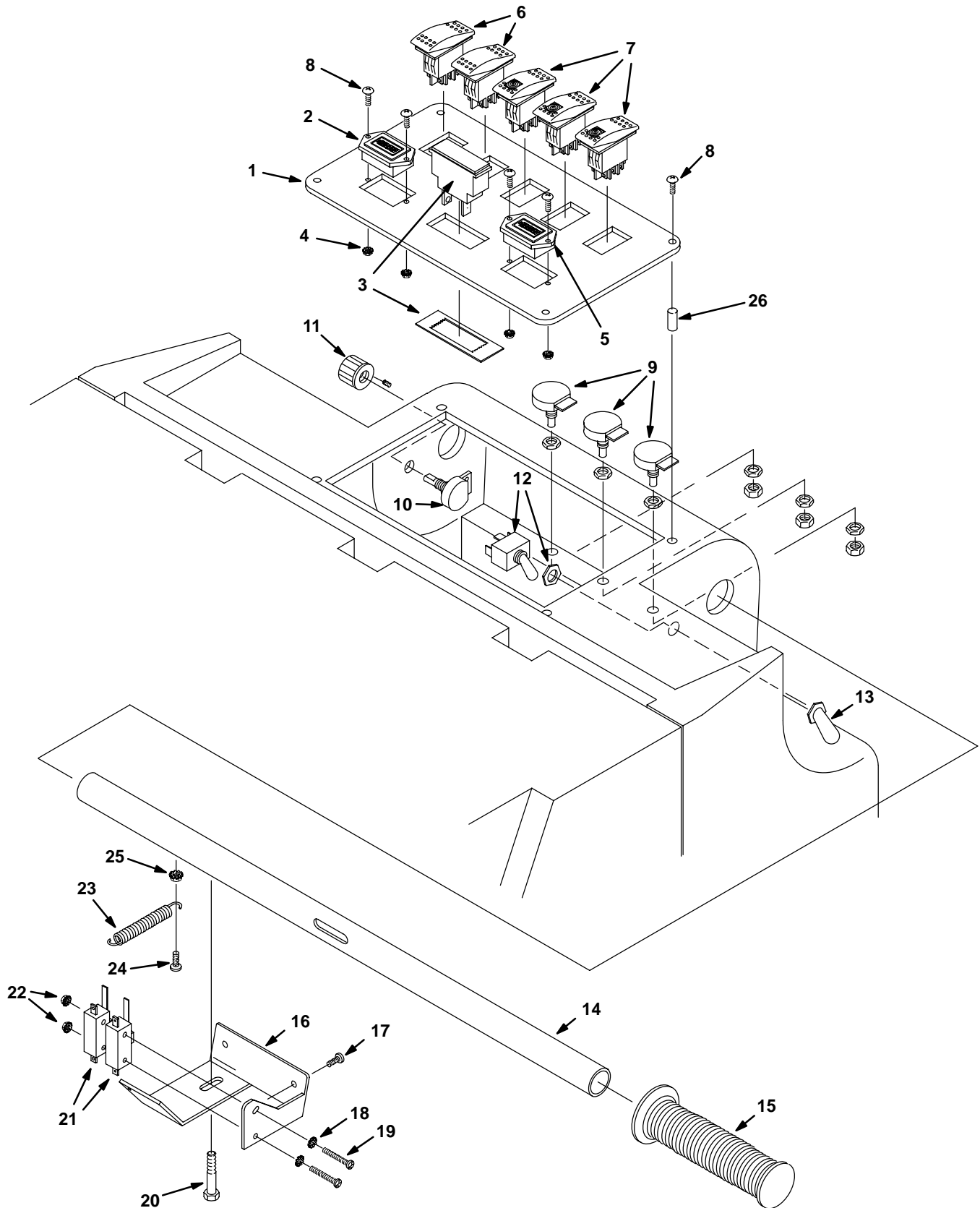

CONTROL CONSOLE GROUP

REF	PART #	DESCRIPTION	QTY.
1	609177	PLATE, DASH	1
2	1010555	●METER, HOUR	1
3	130046	●METER, BRUSH PRESSURE	1
4	140539	NUT, #6-32 KEP	4
5	130779	●METER, BATTERY	1
6	602919	●SWITCH, ROCKER	2
7	601107	●SWITCH, ROCKER, LIGHTED	3
8	140810	SCREW, #6-32X3/8 RNDPHL	8
▽ N/S	609061	WIRE HARNESS, MAIN	1
▲ 9	130775	●POTENTIOMETER, LOCKABLE	3
▲ 10	130776	●POTENTIOMETER	1
11	606550	●KNOB, SPEED CONTROL	1
12	601108	●SWITCH, TOGGLE	1
13	130753	●BOOT, SWITCH	1

REF	PART #	DESCRIPTION	QTY.
14	601001	HANDLE, TUBE	1
15	200823	●GRIP, HANDLE	2
16	605814	BRACKET, SWITCH MOUNT	1
17	140864	SCREW, 1/4-20X3/4 TRSPHL	2
18	140019	WASHER, #6 LOCK	2
19	140830	SCREW, #6-32X1-5/8 PANPHL	2
20	605811	SCREW, 5/16-18X3 HXHDCP	1
21	614003	●SWITCH, SNAP ACTION	2
22	140539	NUT, #6-32 KEP	2
23	069764069	SPRING	1
24	140823	SCREW, #10-24X5/8 TRSPHL	1
25	140519	NUT, #10-24 KEP	1
26	140497	INSERT, #6-32X3/8	4

▽ ASSEMBLY

▲ INCLUDED IN ASSEMBLY

● RECOMMENDED STOCK ITEMS

N/S - NOT SHOWN

DRIVE GROUP

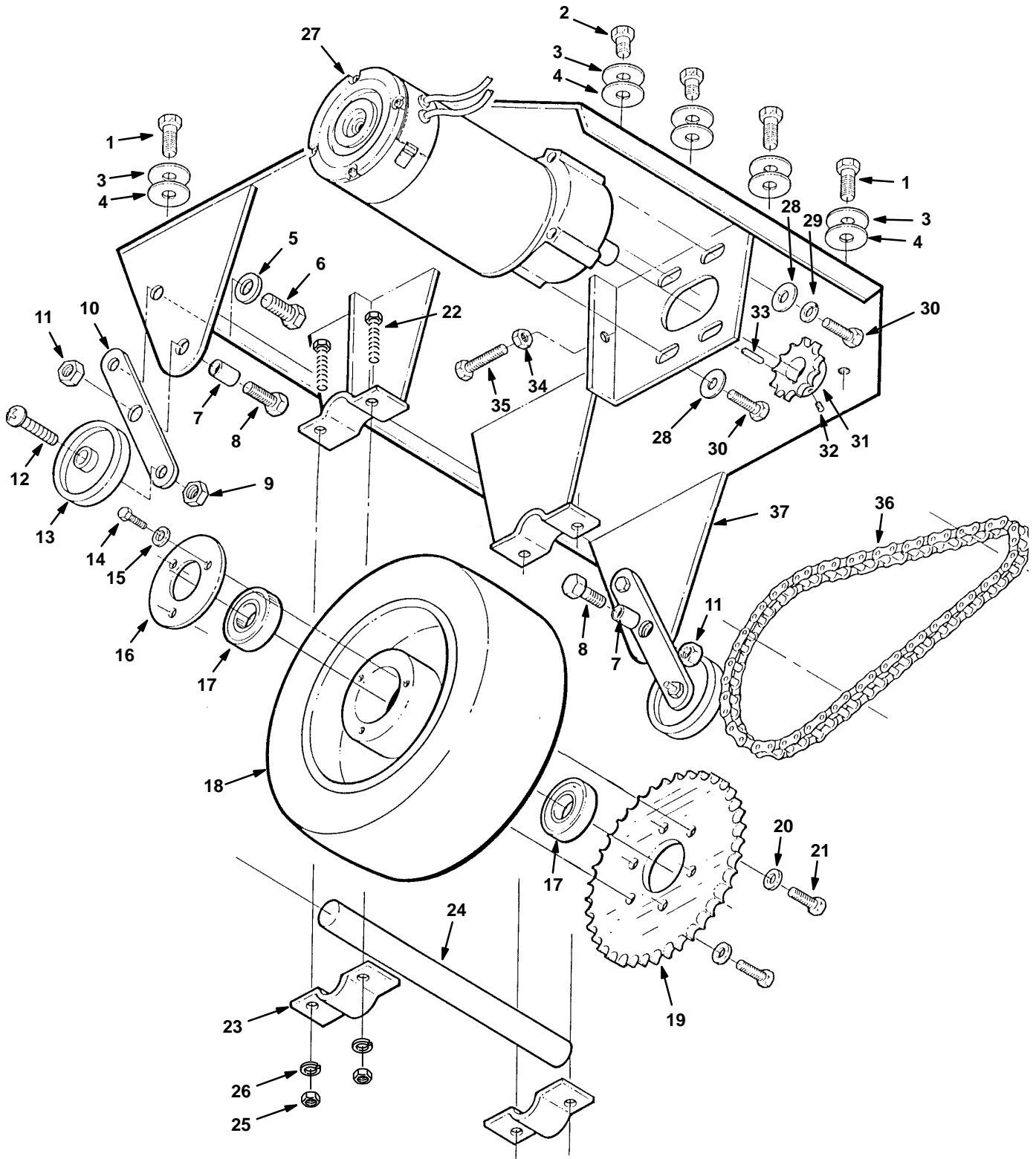

DRIVE GROUP

REF	PART #	DESCRIPTION	QTY.
1	140202	SCREW, 3/8-16X1 HXHDCP	6
2	02994	SCREW, 3/8-16X3/4 HEXHD	2
3	140028	WASHER, 3/8 FLAT	8
4	140008	WASHER, 1/2 FLAT	8
5	140015	WASHER, 5/16 LOCK	2
6	140559	SCREW, 5/16-18X1/2 HXHDCP	2
7	140911	SLEEVE, .50ID, .62OD, .68L	2
8	140204	SCREW, 1/2-13X1-1/2 HXHDCP	2
9	140545	NUT, 3/8-16 FINJAM	2
10	230645.BK	PLATE, SAFETY WHEEL	2
11	140509	NUT, 1/2-13 HXJM	2
12	140943	SCREW, 3/8-16X2 PANPHL	2
13	103007	●WHEEL	2
14	02991	SCREW, 5/16-18X3/4 HEXHD	3
15	140015	WASHER, 5/16 LOCK	3
16	220120.BK	RETAINER, WHEEL BEARING	1
17	140124	●BEARING, WHEEL	2
18	103027	●WHEEL, DRIVE 10" X 4"	1
19	240017	SPROCKET, WHEEL DRIVE	1

REF	PART #	DESCRIPTION	QTY.
20	140015	WASHER, 5/16 LOCK	6
21	140219	SCREW, 5/16-18X1 HEXHD	6
22	140202	SCREW, 3/8-16X1 HXHDCP	4
23	611980	CLAMP, AXLE	2
24	230205	SHAFT, DRIVE WHEEL	1
25	140525	NUT, 3/8-16 HEX	4
26	140017	WASHER, 3/8 LOCK	4
▽ 27	130443	●MOTOR, DRIVE	1
▲	190153	●BRUSH, CARBON (SET OF 2)	1
28	140046	WASHER, 3/8 FLAT	4
29	140017	WASHER, 3/8 LOCK	3
30	611048	SCREW, 3/8-16X1-1/4 HEXHD	4
31	240071	SPROCKET, DRIVE MOTOR	1
32	140859	SCREW, 1/4-20X1/4 SET	2
33	605350	●KEY	1
34	140545	NUT, 3/8-16 FINJAM	1
35	140233	SCREW, 3/8-16X1-3/4 HXHDCP	1
36	240019	●CHAIN, DRIVE	1
37	220107.BK	BRACKET, WHEEL ASSEMBLY	1

▽ ASSEMBLY

▲ INCLUDED IN ASSEMBLY

● RECOMMENDED STOCK ITEMS

PLUMBING SYSTEM GROUP

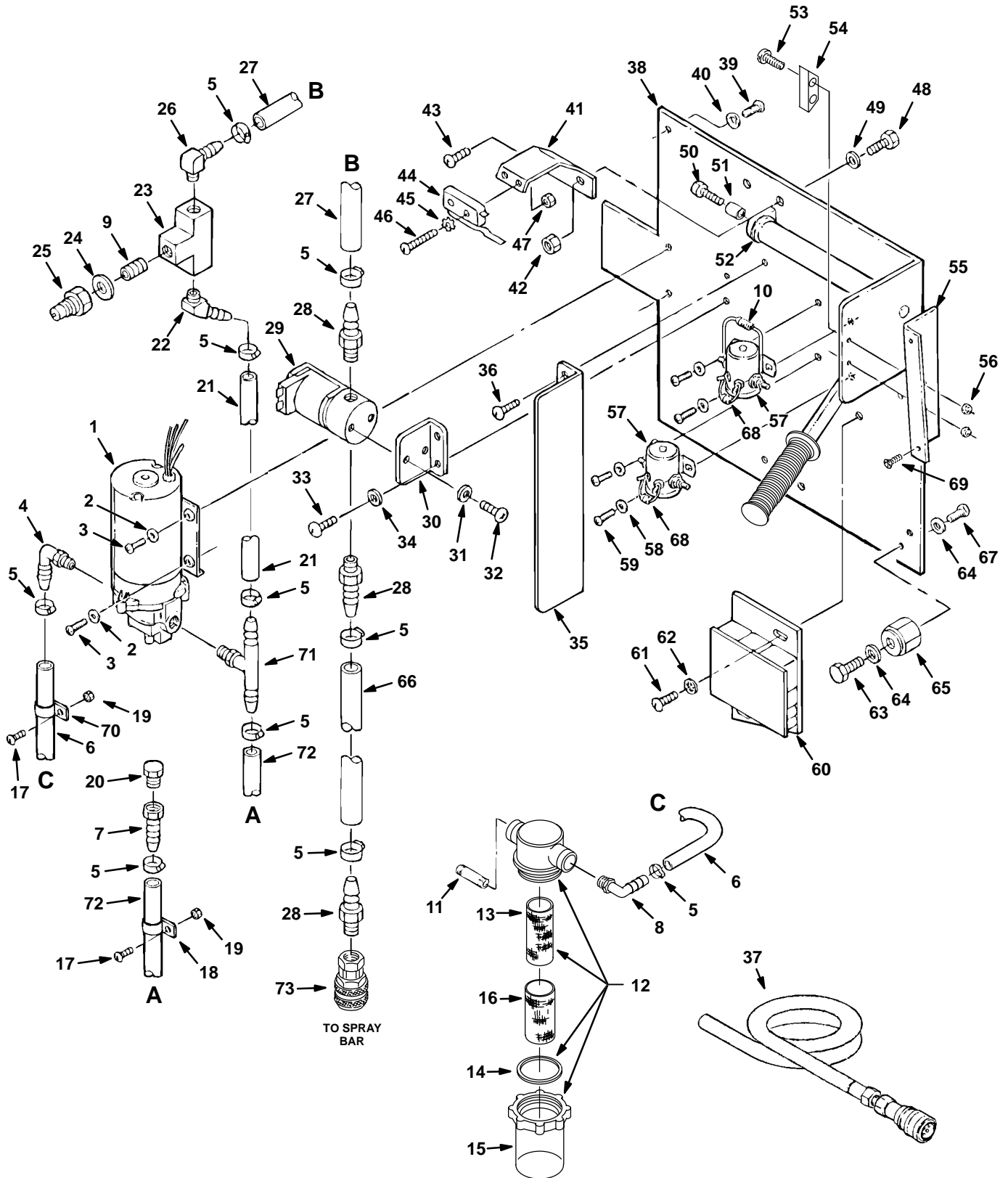

PLUMBING SYSTEM GROUP

REF	PART #	DESCRIPTION	QTY.
1	601142	●PUMP, SOLUTION, 100PSI 36V	1
2	140000	WASHER, 1/4 FLAT	2
3	140881	SCREW, 1/4-20X1 TRSPHL	2
4	150412	FITTING, E90, PM06/BM06	1
5	54333	CLAMP, HOSE 5/16-7/8	10
6	613505	HOSE, 3/8 LP GRAY (6.66 FT)	1
7	150511	FITTING, 1/4F X 3/8H	1
8	150412	FITTING, E90, PM06/BM06	1
9	150615	FITTING, 04PM CLOSE	1
10	604486	DIODE	1
11	601106	FITTING, 3/8M X 3 NIPPLE	1
▽ 12	180615	●ASM., INLINE STRAINER FILTER	1
▲ 13	180616	●FILTER, SCREEN, 80-MESH, SS	1
▲ 14	180617	●GASKET, VITON	1
▲ 15	602000	●BOWL, CLEAR	1
16	180636	●FILTER, SCREEN, 125-MESH, NY	1
17	140900	SCREW, #10-24X3/4 TRSPHL	2
18	140916	CLAMP, CABLE 5/8	1
19	140552	NUT, #10-24 NYLOCK	2
20	150206	FITTING, PLUG, 04PM HEX	1
21	609432	HOSE, 3/8 LP GRAY (1.080 FT)	1
22	605394	FITTING, E45 BM06/PM04	1
23	150706	FITTING, 1/4F TEE	1
24	140058	WASHER, 1/2 FLAT	1
25	150933	FITTING, QDC/04PM	1
26	150419	FITTING, 1/4M X 3/8H 90° ELBOW	1
27	613481	HOSE, 3/8 LP GRAY (.916 FT)	1
28	150516	FITTING, 04PM/06BM	3
29	210046	●VALVE, SOLENOID 36V	1
30	600998	BRACKET, SOLENOID MOUNTING	1
31	140023	WASHER, #8 LOCK	2
32	140801	SCREW, #8-32X3/8 TRSPHL	2
33	140197	SCREW, #10-24X3/8 TRSPHL	2
34	140018	WASHER, #10 LOCK	2
35	230978	PLATE, DIVIDER	1
36	140887	SCREW, #10-24X3/8 PANPHL	2
37	700141	HOSE, SOLUTION TANK CLEAN-OUT	1

REF	PART #	DESCRIPTION	QTY.
38	231029.BK	PLATE, CONTROL	1
39	02991	SCREW, 5/16-18X3/4 HEXHD	5
40	140015	WASHER, 5/16 LOCK	5
41	600975	BRACKET, REVERSE SAFETY SW.	1
42	140546	NUT, 5/16-18 NYLOCK	1
43	140197	SCREW, #10-24X3/8 TRSPHL	1
44	398525	●SWITCH	1
45	140019	WASHER, #6 LOCK	2
46	140829	SCREW, #6-32X1 PANPHL	2
47	140066	NUT, #6-32 NYLCK	2
48	140219	SCREW, 5/16-18X1 HXHDCP	1
49	140015	WASHER, 5/16 LOCK	1
50	140237	SCREW, 1/2-13X1 HXHDCP	1
51	150116	BUSHING	1
52	140040	WASHER, POLY	2
53	140868	SCREW, 1/4-20X5/8 SKHDCP	2
54	100721	PLATE, LOCK	1
55	220115	BRACKET, SUPPORT	1
56	140524	NUT, 1/4-20 KEP	2
57	130733	●CONTACTOR, SOLENOID, SPNO 36V	2
58	140011	WASHER, 3/16 FLAT	4
59	140197	SCREW, #10-24X3/8 TRSPHL	4
60	602827	●BOARD, SPEED W/HEAT SINK	1
61	140887	SCREW, #10-24X3/8 PANPHL	2
62	140018	WASHER, #10 LOCK	2
63	140259	SCREW, 1/4-20X5/8 HEXHD	1
64	140016	WASHER, 1/4 LOCK	2
65	578427	TERMINAL, STANDOFF	1
66	613501	HOSE, 3/8 LP GRAY (5.00 FT)	1
67	24672	SCREW, 1/4-20X3/4 HEXHD	1
68	606404	DIODE ASSEMBLY	2
69	140861	SCREW, 1/4-20X1 FLTHD	2
70	140318	CLAMP, CABLE 7/8	1
71	150715	FITTING, 3/8M X 3/8H X 3/8H TEE	1
72	613493	HOSE, 3/8 LP GRAY (3.00 FT)	1
73	150913	COUPLER, QUICK FEMALE	1

▽ ASSEMBLY

▲ INCLUDED IN ASSEMBLY

● RECOMMENDED STOCK ITEMS

BRUSH HEAD GROUP

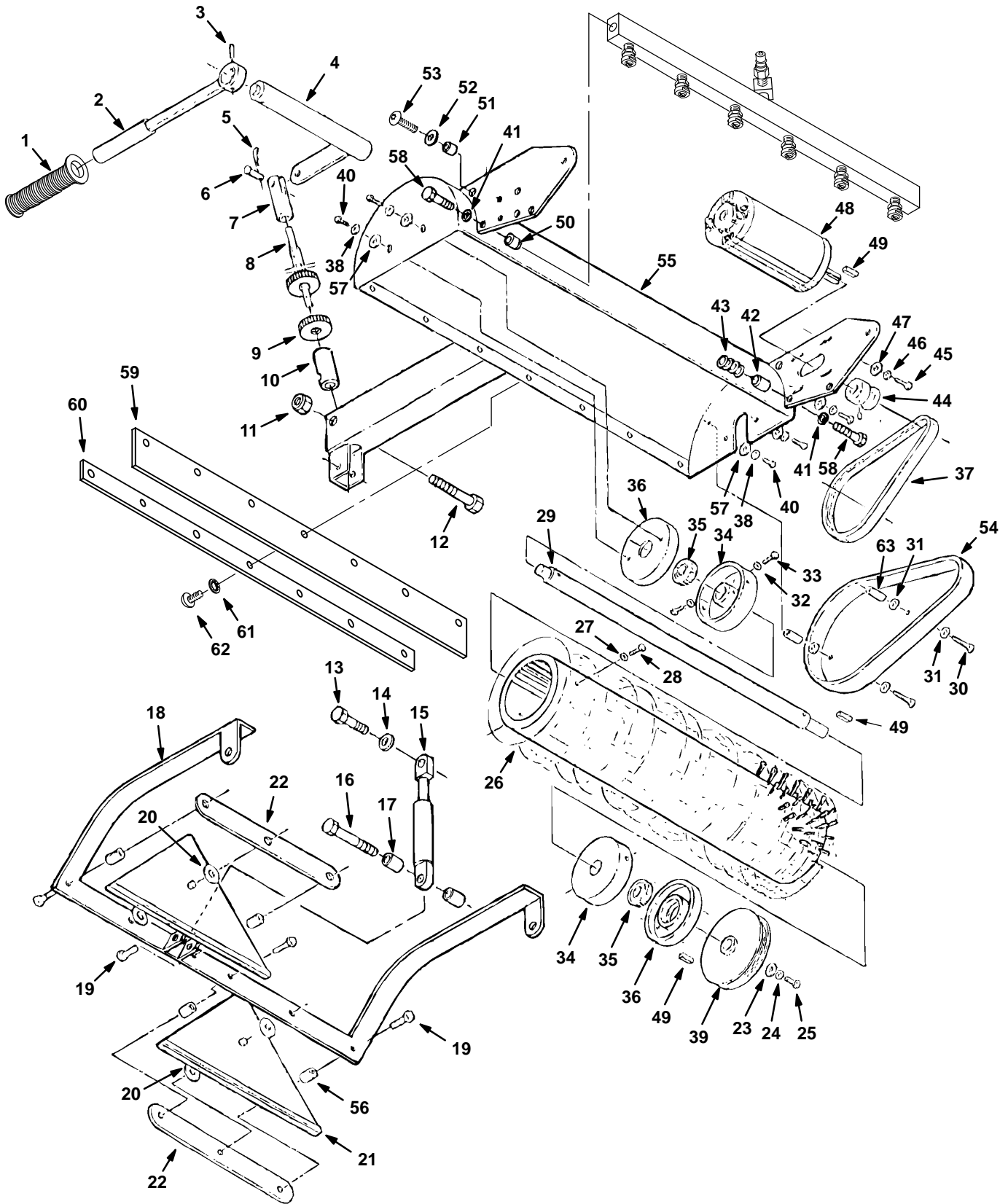

BRUSH HEAD GROUP

REF	PART #	DESCRIPTION	QTY.
1	200823	●GRIP, HANDLE	1
2	230210	ARM, LIFT, HEAD	1
3	140618	●PIN, ROLL	1
4	230207	SHAFT, LIFT	1
5	140626	●PIN, HITCH	1
6	140608	●PIN, CLEVIS	1
7	230309	CLEVIS, LIFT ROD	1
8	231038	ASSEMBLY, LIFT ROD	1
9	231037	NUT, BRUSH ADJUST	1
10	231036	ADAPTER, LIFT ROD	1
11	02931	NUT, 1/2 NYLOCK	1
12	140234	SCREW, 1/2-13X2-1/2 HXHDCP	1
13	140216	SCREW, 5/16-18X1-1/2 HXHDCP	2
14	140027	WASHER, 5/16 FLAT	2
15	140446	SPRING, GAS CYLINDER	2
16	140355	SCREW, 5/16-18X2-1/2 HXHDCP	2
17	140140	BUSHING, .31 X .44 X .35	4
18	230979.BK	BRACKET, PICKUP TOOL MOUNT	1
19	140204	SCREW, 1/2-13X1-1/2 HXHDCP	4
20	140040	WASHER, 1/2	4
21	604958	TOOL, PICKUP	2
22	100729	PLATE, PICKUP TOOL	2
23	140003	WASHER, 1/4 FENDER	1
24	140016	WASHER, 1/4 LOCK	1
25	140259	SCREW, 1/4-20X5/8 HXHDCP	1
▽	611844	●ASSEMBLY, BRUSH	1
▲	611792	●BRUSH, CYLINDER	1
▲	140015	WASHER, 5/16 LOCK	4
▲	140221	SCREW, 5/16-18X1-1/4 HXHDCP	4
▲	230206	SHAFT, BRUSH	1
30	140869	SCREW, #10-24X1-3/4 PANPHL	2
31	140011	WASHER, 3/16 FLAT	4

REF	PART #	DESCRIPTION	QTY.	
▲	32	140016	WASHER, 1/4 LOCK	4
▲	33	140259	SCREW, 1/4-20X5/8 HEXHD	4
▲	34	240014	ADAPTER, MOUNT, BRUSH	2
▲	35	140123	●BEARING, BALL	2
▲	36	240015	CAP, BEARING	2
37	240126	●BELT, DRIVE, BRUSH	1	
38	140016	WASHER, 1/4 LOCK	4	
39	240013	SHEAVE, BRUSH SHAFT	1	
40	24672	SCREW, 1/4-20X3/4 HXHDCP	4	
41	140016	WASHER, 1/4 LOCK	2	
42	230993	PIN, MANIFOLD MOUNT	1	
43	578140000	SPRING	1	
44	240016	SHEAVE, BRUSH MOTOR	1	
45	140208	SCREW, 1/4-20X1 HXHDCP	4	
46	140016	WASHER, 1/4 LOCK	4	
47	140000	WASHER, 1/4 FLAT	4	
48	130444	●MOTOR, BRUSH 1/2 HP	1	
49	140628	●KEY, 3/16X3/16X1	2	
50	230992	PIN, MANIFOLD MOUNT	1	
51	140144	SLEEVE, .318 X .496	2	
52	140028	WASHER, 3/8 FLAT	2	
53	140847	SCREW, 3/8-16 X 1	2	
54	611717	COVER, DRIVE BELT	1	
55	230983.BK	HOUSING, BRUSH	1	
56	140911	SLEEVE, .50ID, .62OD, .68L	4	
57	140000	WASHER, 1/4 FLAT	4	
58	01696	SCREW, 1/4-20X1/2 HEXHD	2	
59	240038	GUARD, SPLASH	1	
60	100719.BK	●STRAP, SPLASH GUARD	1	
61	140018	WASHER, #10 LOCK	7	
62	140892	SCREW, #10-24X1/2 RNDPHL	7	
63	140917	SPACER, .19X.31X1.50 NYLON	2	

▽ ASSEMBLY

▲ INCLUDED IN ASSEMBLY

● RECOMMENDED STOCK ITEMS

PARTS LIST

SPRAY BAR GROUP

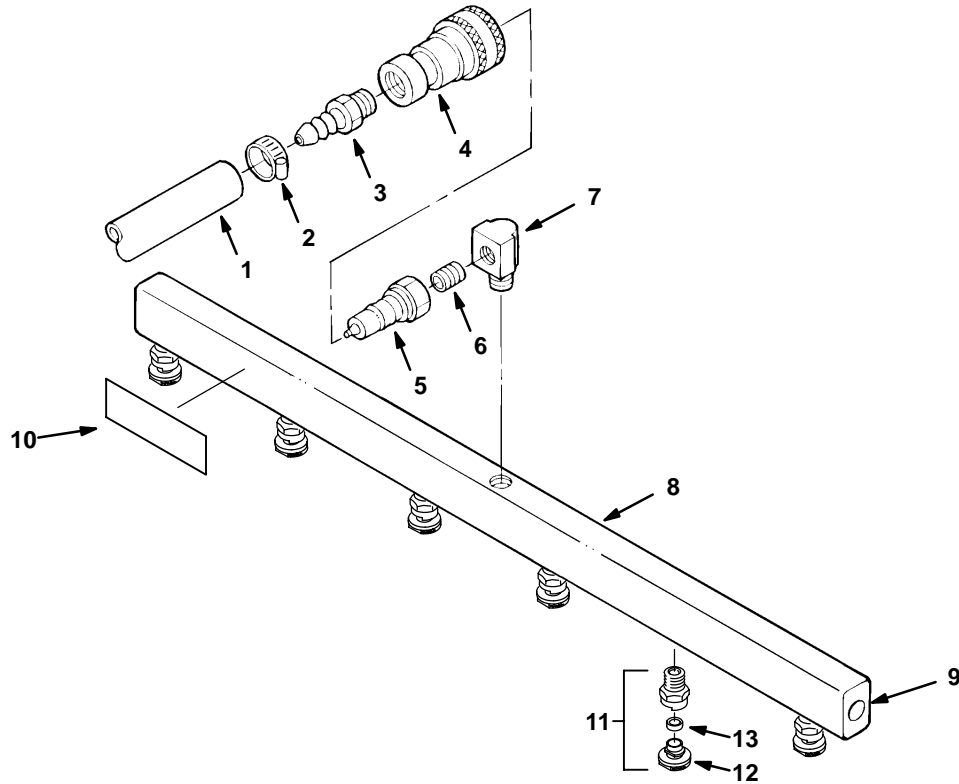

REF	PART #	DESCRIPTION	QTY.
1	613501	HOSE, 3/8 LP GRAY (5.00 FT)	1
2	54333	CLAMP, HOSE 5/16-7/8	1
3	150516	FITTING, 04PM/06BM	1
4	150913	COUPLER, QUICK FEMALE	1
∇	601143	ASSEMBLY, SPRAY BAR	1
▲ 5	150933	FITTING, QDC/04PM	1
▲ 6	150615	FITTING, 04PM CLOSE	1

REF	PART #	DESCRIPTION	QTY.
▲ 7	150430	FITTING, 1/8M X 1/4F, 90° ELBOW	1
▲ 8	230974	SPRAY BAR, 6-JET	1
▲ 9	150208	FITTING, 1/8 PLUG	2
▲ 10	120248	DECAL, FRONT	1
▲ ∇ 11	201008	●FITTING, JET	6
▲ 12	603092	●REPLACEMENT TIP 11002 FOR 201008	6
▲ 13	201015	●SEAL, SPRAY TIP	6

∇ ASSEMBLY

▲ INCLUDED IN ASSEMBLY

● RECOMMENDED STOCK ITEMS

PUMP BREAKDOWN

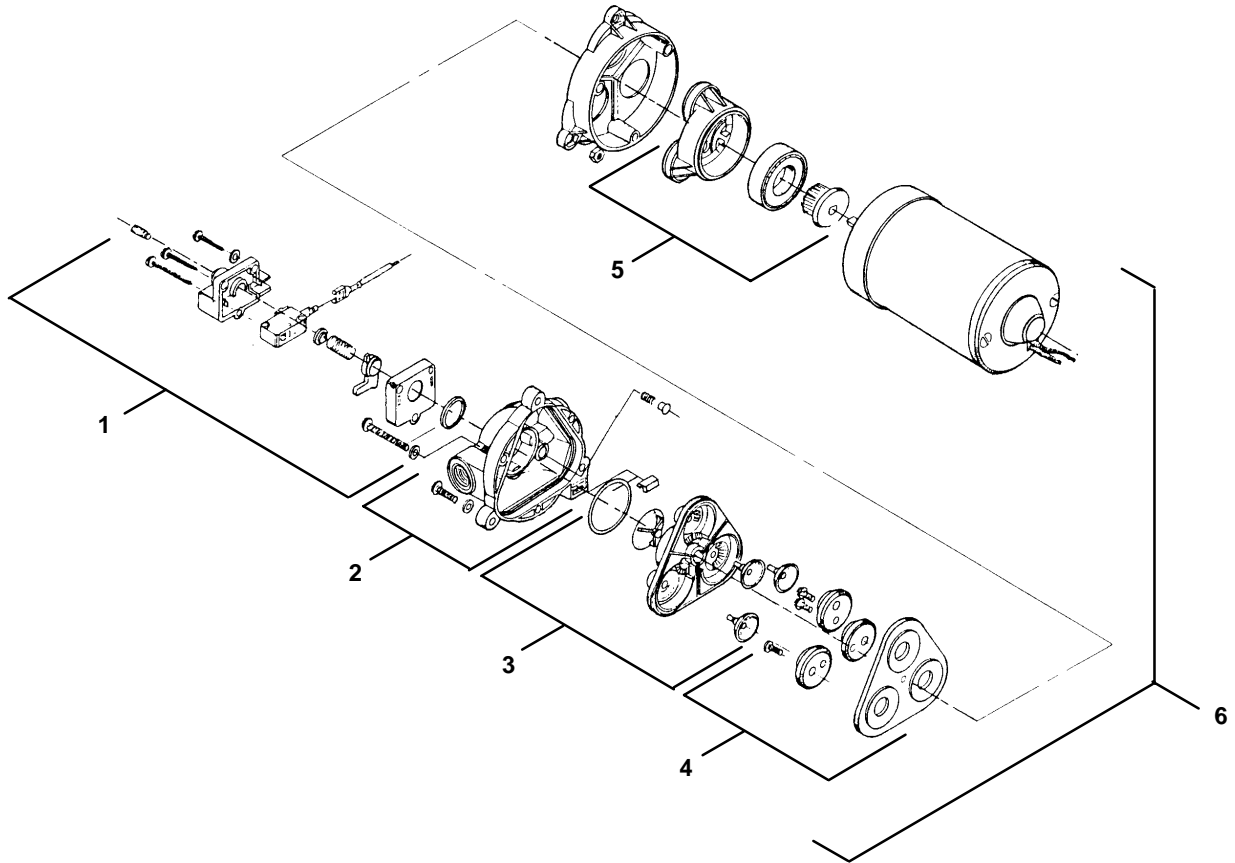

REF	PART #	DESCRIPTION	QTY.
1	190129	KIT, PRESSURE SWITCH	1
	190172	KIT, PRESSURE SWITCH (VITON)	1
	190134	KIT, DIAPHRAGM ONLY	1
2	190128	KIT, UPPER PUMP HOUSING	1
	190124	KIT, CHECK VALVE ONLY	1

REF	PART #	DESCRIPTION	QTY.
3	190171	KIT, VALVE (VITON)	1
4	190131	KIT, SERVICE	1
5	190130	KIT, LOWER PUMP HOUSING	1
6	601142	PUMP, SOLUTION, 100PSI 36V	1

VACUUM MOTOR BREAKDOWN

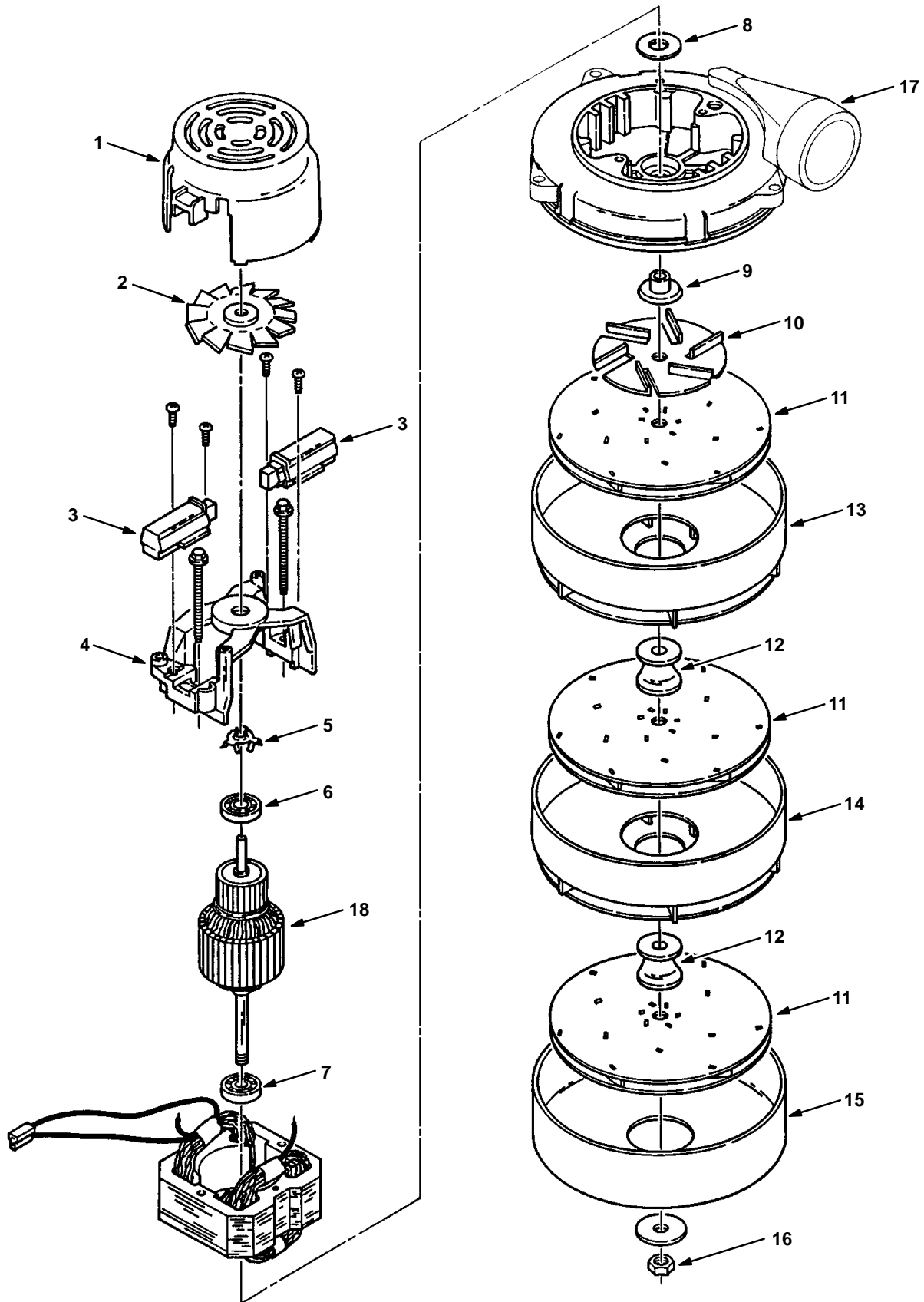

VACUUM MOTOR BREAKDOWN

REF	PART #	DESCRIPTION	QTY.
▽	398521	MOTOR, VAC 5.7D, 3-STAGE, 36V	1
▲ 1	398511	HOUSING	1
▲ 2	398512	FAN	1
▲ 3	398513	●BRUSH, CARBON (SET OF 2)	2
▲ 4	398514	BRACKET	1
▲ 5	01856	SPRING, BRG, MOTOR, VAC FAN	1
▲ 6	398515	BEARING	1
▲ 7	01837	BEARING, MOTOR, VAC FAN	1
▲ 8	37912	WASHER, NEOPRENE, VAC PAN	1
▲ 9	398516	SPACER	1

▽ ASSEMBLY

▲ INCLUDED IN ASSEMBLY

REF	PART #	DESCRIPTION	QTY.
▲ 10	01971	IMPELLER, VAC FAN	1
▲ 11	18628	IMPELLER, VAC FAN	3
▲ 12	398517	SPACER	2
▲ 13	61300	HOUSING, IMPELLER, VAC FAN	1
▲ 14	61297	HOUSING, IMPELLER, VAC FAN	1
▲ 15	398518	FAN SHELL	1
▲ 16	37929	NUT, IMPELLER, VAC FAN	1
▲ 17	60386	HOUSING, OUTLET, VAC FAN	1
▲ 18	398519	ARMATURE	1

127 mm (5 in) HAND TOOL

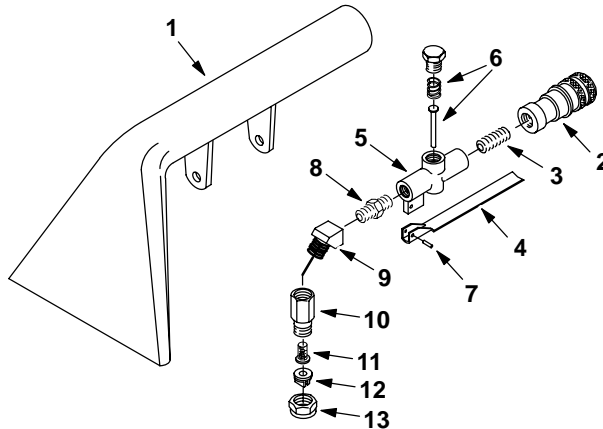

REF	PART #	DESCRIPTION	QTY.
▽	200505	●ASM., HAND TOOL 5"	1
▲ 1	200431.BK	TOOL, HAND	1
▲ 2	150913	FITTING, 1/4F QD FML COUPLER	1
▲ 3	150615	NIPPLE, CLOSE	1
▲ 4	200905	TRIGGER, HAND TOOL	1
▲ 5	210210	●VALVE, FLOW CONTROL	1
▲ 6	190600	VALVE PIN & SPRING	1

REF	PART #	DESCRIPTION	QTY.
▲ 7	140609	PIN, ROLL 3/16	1
▲ 8	150606	NIPPLE, HEX 1/4	1
▲ 9	150403	ELBOW, ST 1/4 45°	1
▲ 10	200992	BODY, SPRAY 1/4F	1
▲ 11	200996	SCREEN, SPRAY NOZZLE	1
▲ 12	200965	●TIP, SPRAY #8002	1
▲ 13	200994	CAP, SPRAY BODY	1

▽ ASSEMBLY

▲ INCLUDED IN ASSEMBLY

● RECOMMENDED STOCK ITEMS

76 mm (3 in) CREVICE TOOL

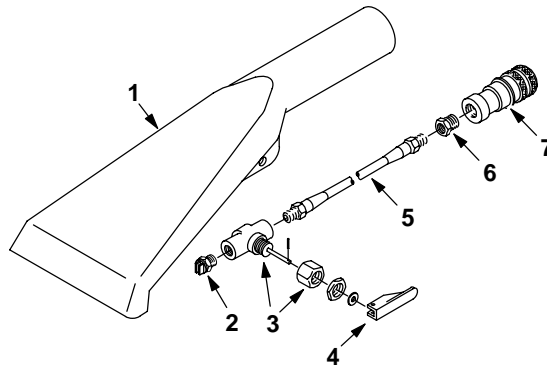

REF	PART #	DESCRIPTION	QTY.
▽	200517	●ASM., CREVICE TOOL SER.60	1
▲ 1	200436.BK	TOOL, CREVICE BLACK	1
▲ 2	200975	●FITTING, TIP #5002 V-JET	1
▲ 3	210014	●VALVE, TOGGLE W/NUT	1

REF	PART #	DESCRIPTION	QTY.
▲ 4	210020	POSITIONER, VALVE HANDLE	1
▲ 5	160106	HOSE, SOLUTION	1
▲ 6	150100	FITTING, 1/4MX1/8F BUSHING	1
▲ 7	150913	FITTING, 1/4F QD FML COUPLER	1

▽ ASSEMBLY

▲ INCLUDED IN ASSEMBLY

● RECOMMENDED STOCK ITEMS

LOW PRESSURE UPHOLSTERY TOOL

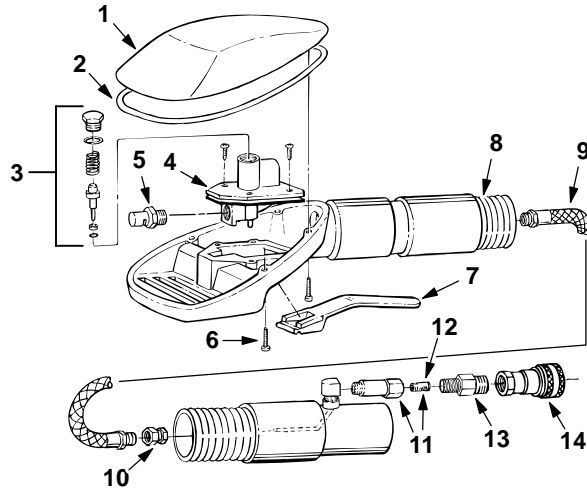

REF	PART #	DESCRIPTION	QTY.
▽	200540	●ASSEMBLY, UPHOLSTERY TOOL	1
▲ 1	200845	COVER	1
▲ 2	200843	GASKET	1
▲ 3	190631	●KIT, VALVE ASM.	1
▲ 4	210226	●VALVE, LP	1
▲ 5	200991	●NOZZLE	1
▲ 6	200838	SCREW	4
▲ 7	200840	TRIGGER	1

REF	PART #	DESCRIPTION	QTY.
▲ 8	200844	●HOSE, VACUUM	1
▲ 9	200837	●HOSE, SOLUTION	1
▲ 10	200848	FITTING	1
▲ 11	200842	FILTER	1
▲ 12	200841	SCREEN, FILTER	1
▲ 13	150606	FITTING, 1/4MX1/4M	1
▲ 14	150913	●COUPLER	1

▽ ASSEMBLY

▲ INCLUDED IN ASSEMBLY

● RECOMMENDED STOCK ITEMS

330mm (13 in) LOW PRESSURE FLOOR TOOL

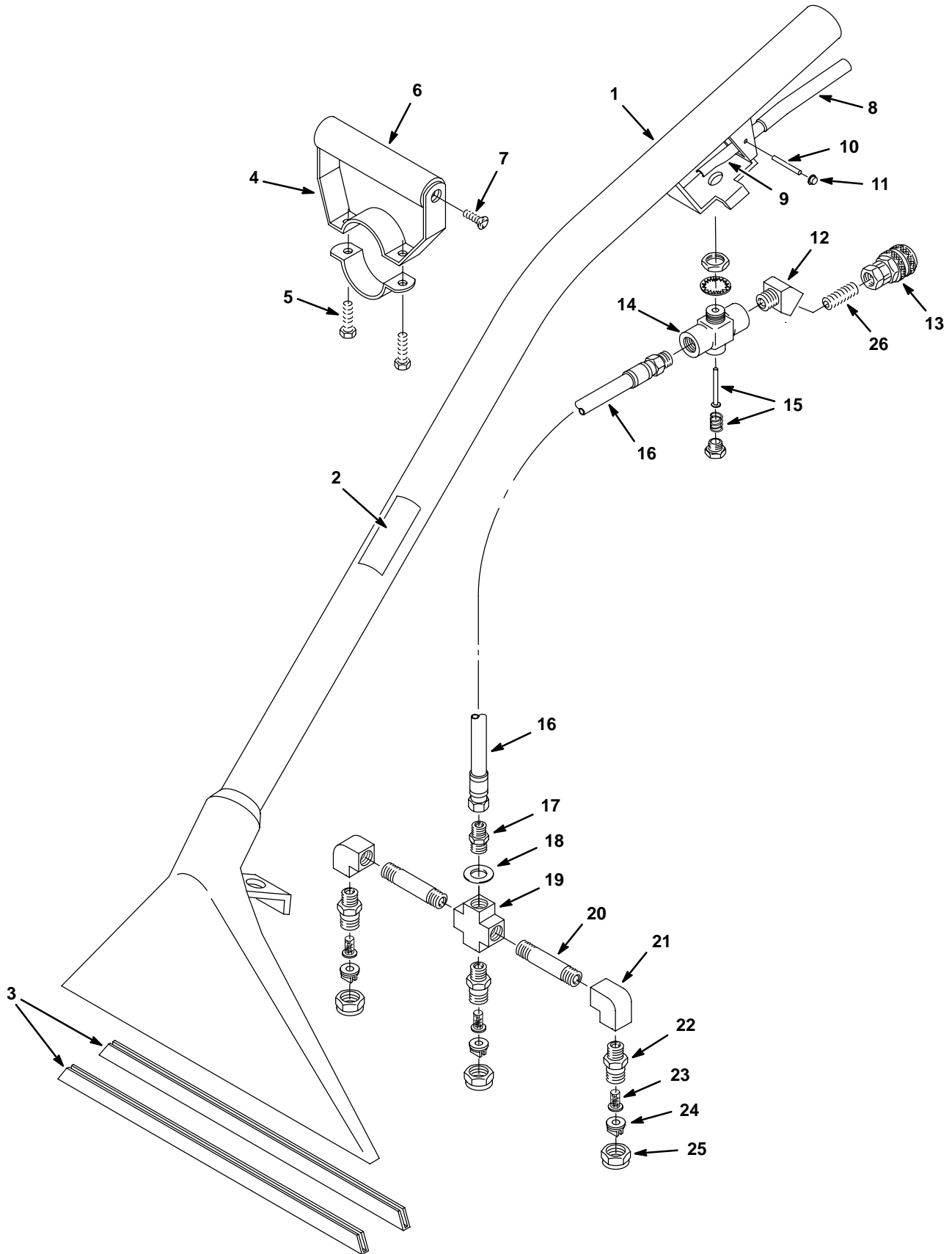

330mm (13 in) LOW PRESSURE FLOOR TOOL

REF	PART #	DESCRIPTION	QTY.
▽	600048	●ASM., WAND LOW PRESSURE	1
▲ 1	200403.BK	TOOL, FLOOR BLACK	1
▲ 2	120846	DECAL, LOW PRESSURE TOOL	1
▲ 3	200939	●SHOE, 330MM (13 IN) FLR TOOL	2
▲▽ 4	200927	GRIP, HAND ADJ. COMPLETE	1
▲ 5	140259	SCREW, 1/4-20X5/8	2
▲ 6	200912	GRIP, HANDLE FOAM	1
▲ 7	140834	SCREW, 1/4-20X5/8	2
▲ 8	200809	SLEEVE, HANDLE	1
▲ 9	200902	HANDLE, VALVE	1
▲ 10	140605	PIN, HANDLE	1
▲ 11	140520	NUT, 1/4 PUSH BLK	2
▲ 12	150403	FITTING, 1/4MX1/4F 45 STR	1
▲ 13	150913	●FITTING, 1/4F QD CPLR SER 60	1

REF	PART #	DESCRIPTION	QTY.
▲▽ 14	210150	●VALVE, FLOW CONTROL	1
▲ 15	190603	●KIT, VALVE PIN AND SPRING	1
▲ 16	160170	ASM, HOSE LOW PRESSURE	1
▲ 17	150606	FITTING, 1/4MX1-3/8HEXNIP	1
▲ 18	140058	WASHER, .543X.875X.062 WAND	1
▲▽	700062	ASM., SPRAYBAR WO/TIPS	1
▲ 19	150700	CROSS, 1/4 FPT	1
▲ 20	150600	FITTING, 1/4MX2" NIPPLE	2
▲ 21	150401	FITTING, 1/4FX1/4F ELBOW 90	2
▲ 22	200993	SPRAY BODY, 1/4" MALE	3
▲ 23	200996	●FILTER, SCREEN 100 MESH	3
▲ 24	200964	●FITTING, TIP 11003 T-JET	3
▲ 25	200994	●CAP, SPRAY BODY	3
▲ 26	150615	FITTING, 1/4MX7/8 CLSNIP	1

▽ ASSEMBLY

▲ INCLUDED IN ASSEMBLY

● RECOMMENDED STOCK ITEMS

406mm (16 in) LOW PRESSURE FLOOR TOOL

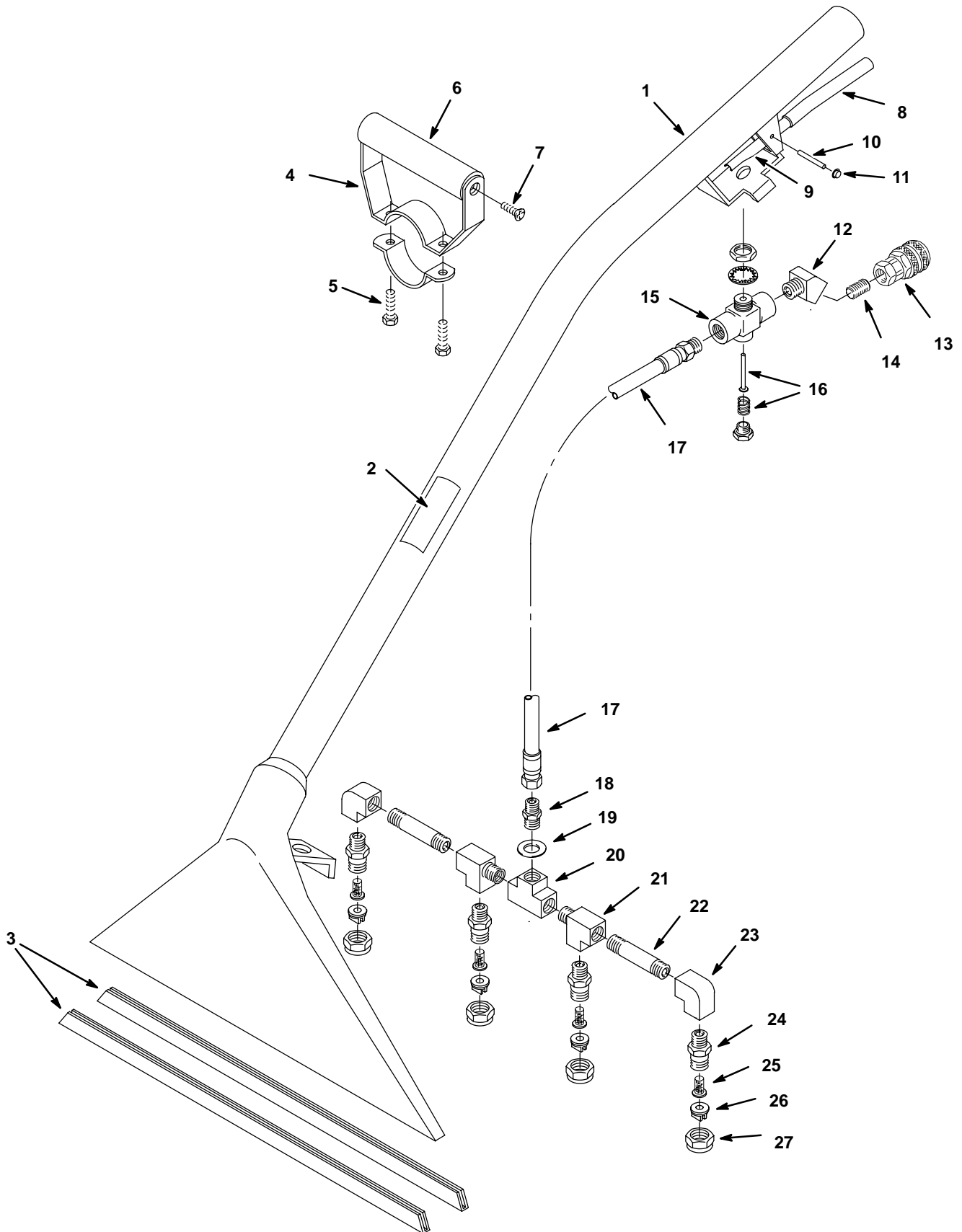

406mm (16 in) LOW PRESSURE FLOOR TOOL

REF	PART #	DESCRIPTION	QTY.
▽	200503	●ASM., FLOOR TOOL	1
▲ 1	200411.BK	TOOL, FLOOR 406MM (16 IN)	1
▲ 2	120846	DECAL, LOW PRESSURE TOOL	1
▲ 3	200956	●SHOE, 406MM (16 IN) FLR TOOL	2
▲▽ 4	200927	GRIP, HAND ADJ. COMPLETE	1
▲ 5	140259	SCREW, 1/4-20X5/8	2
▲ 6	200912	GRIP, HANDLE FOAM	1
▲ 7	140834	SCREW, 1/4-20X5/8	2
▲ 8	200809	SLEEVE, HANDLE	1
▲ 9	200902	HANDLE, VALVE	1
▲ 10	140605	PIN, HANDLE	1
▲ 11	140520	NUT, 1/4 PUSH BLK	2
▲ 12	150403	FITTING, 1/4MX1/4F 45 STR	1
▲ 13	150913	●COUPLER, SER. 60	1
▲ 14	150615	NIPPLE, CLOSE 1/4	1

REF	PART #	DESCRIPTION	QTY.
▲▽ 15	210150	●VALVE, FLOW CONTROL	1
▲ 16	190603	●KIT, VALVE PIN AND SPRING	1
▲ 17	160170	ASM, HOSE LOW PRESSURE	1
▲ 18	150606	FITTING, 1/4MX1-3/8HEXNIP	1
▲ 19	140058	WASHER, .543X.875X.062 WAND	1
▲▽	700656	ASM., SPRAYBAR 16" WO/TIPS	1
▲ 20	150706	FITTING, 1/4F TEE	1
▲ 21	150709	FITTING, 1/4F X 1/4F X 1/4M	2
▲ 22	150600	FITTING, 1/4MX2" NIPPLE	2
▲ 23	150401	FITTING, 1/4FX1/4F ELBOW 90	2
▲ 24	200993	SPRAY BODY, 1/4" MALE	4
▲ 25	200996	●FILTER, SCREEN 100 MESH	4
▲ 26	200964	●FITTING, TIP 11003 T-JET	4
▲ 27	200994	●CAP, SPRAY BODY	4

▽ ASSEMBLY

▲ INCLUDED IN ASSEMBLY

● RECOMMENDED STOCK ITEMS

SOLUTION AND VACUUM HOSES

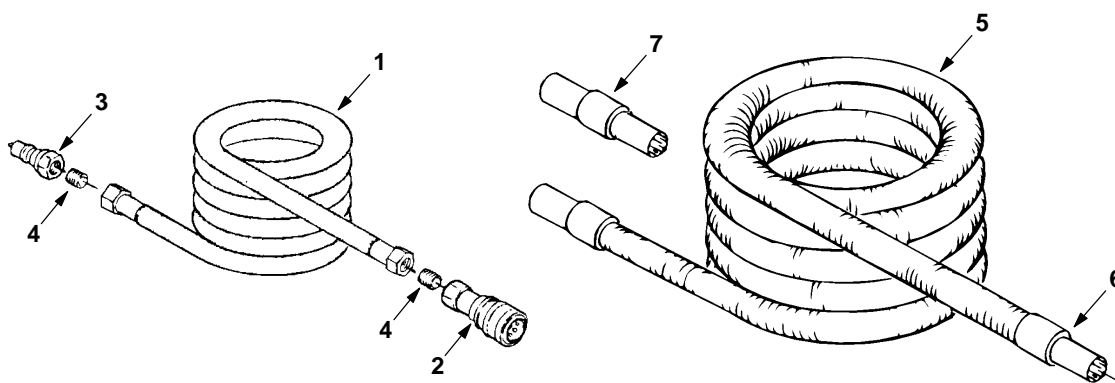

REF	PART #	DESCRIPTION	QTY.
▽ 1	160185	HOSE, SOLUTION 4.6M (15')	1
	610792	HOSE, SOLUTION 7.6M (25')	1
	160192	HOSE, SOLUTION 15.2M (50')	1
▲ 2	150913	●COUPLER, QUICK SER. 60	1
▲ 3	150933	PLUG, QUICK COUPLER	1
▲ 4	150615	NIPPLE	2

REF	PART #	DESCRIPTION	QTY.
▽ 5	160400	HOSE, VACUUM 4.6M (15')	1
	160401	HOSE, VACUUM 7.6M (25')	1
	160402	HOSE, VACUUM 15.2M (50')	1
▲ 6	160430	●CUFF, HOSE 1-1/2"	2
7	160451	●CONNECTOR, VAC HOSE 1-1/2"	1

▽ ASSEMBLY

▲ INCLUDED IN ASSEMBLY

● RECOMMENDED STOCK ITEMS