SC7740

Sweeper/Scrubber



Operator's Manual

READ THIS BOOK

This book has important information for the use and safe operation of this machine. Failure to read this book prior to operating or attempting any service or maintenance procedure to your machine could result in injury to you or to other personnel; damage to the machine or to other property could occur as well. you must have training in the operation of this machine before using it.

All directions given in this book are as seen from the operator's position at the rear of the machine.

American-Lincoln®

TABLE OF CONTENTS - OPERATIONS

Specifications	1-4
Machine Dimensions	1-6
Machine Preparation	1-7
Preparing The Machine For Operation	1-7
Safety Instructions	1-8
Operations of Controls and Gauges	1-11
Light Switch	1-11
Dust Control/Filter Shaker Switch	1-11
Main Broom/Side Broom Switch	1-11
Scrub Deck Switch	1-11
Engine Speed Switch	1-12
Squeegee/Vac Switch	1-12
Hopper Switch	1-12
ESP Switch (Option)	1-12
Key Switch	1-13
Hour Meter	1-13
Fuel Gauge/LP Indicator Light	1-13
Back-UP Alarm Switch (Option)	1-13
Solution Control Knob	1-13
Warning Bank	1-14
Engine Temp Light	1-14
Engine Oil Pressure Light	1-14
Charging System Light	1-14
High Recovery Light	1-14
Low Solution Light	1-14
Hopper Safety Arm	1-15
--To Engage Safety Arm	1-15
Seat Position Adjustment	1-15
Directional Control Pedal	1-15
Hydraulic Reservoir Level Sight Gauge	1-16
Horn Button	1-16
Choke	1-16
Operating Instructions	1-17
Pre-Start Checklist	1-17
Starting Gas Machines	1-17
Starting LP Machines	1-17
Post-Operation Checklist	1-17
Helpful Hints For Cleaning Operation	1-18
ESP System Operating Instructions	1-19
Scrubbing System - How It Works	1-19
Non-Recycling Or Standard Scrubbing System - How It Works	1-19
ESP Recycling ON/OFF Switch (Option)	1-19
Recovery Or ESP System - How It Works	1-19
Ordering Parts	1-20

DIMENSIONS

- Length - 89 in. (223 cm)
- Width - 47 in. (119.3 cm)
- Height - 59 in. (152 cm)
- Height w/Overhead Guard - 81.2 in. (206.2 cm)
- Wheel Base - 38.6 in. (98.0 cm)

CLEANING PATH

- Scrubbing - 40 in. (101 cm)
- 46 in. (117 cm)
- Sweeping - 46 in. (117 cm)
- Edge Cleaning - 6 in. (15 cm) Right Side 46 in. (117 cm) only

TRANSPORT SPEED

- 0-4 MPH (0-6.4 kph)

STEERING

- Rack & Pinion 90°-90° with Hydraulic Assist

TURNING RADIUS

- Left - 59 in. (150 cm)
- Right - 59 in. (150 cm)
- Aisle "U" Turn - 87 in. (221 cm)

WEIGHT

- Standard Machine (Battery) - 2550lbs. (1157kg.) without battery
- 3580lbs. (1623.9kg.) Operating

TIRES

- Front Solid Urethane - Two (2) 16 in (41cm) x 3.75 in (8.26 cm)
- Rear Solid Rubber - One (1) 16 in (41 cm) x 4.00 in (10.16cm)

RAMP CLIMBING

- Transporting 12°
- Operating 6°

INSTRUMENTS AND CONTROLS

- Main/Side Broom Switch
- Low LP Indicator Light
- Squeegee Switch
- Recovery Tank Full Light
- Scrub Deck Switch
- Horn Button
- Solution Control Knob
- Hopper Switch
- Parking Brake
- Key Switch
- Hour Meter
- Fuel Gauge
- Choke
- Dust Control Switch(with certain models)
- Low Solution Light
- Filter Shaker Switch
- Engine Speed Switch
- Directional Control Pedal

SCRUBBING SYSTEM

- Brush Size-46" (116.84 cm) - Three (3) 16" (40.6cm) Diameter
- Brush Size-40" (101.4 cm) - Two (2) 20" (51cm) Diameter
- Scrub Deck Down Force - 300lbs.(136.0kg.)
- Brush Removal - No Tool

BRUSH OPTIONS

- Nylon Amerifil (.025)
- Proex Amerifil (.040)

SPECIFICATIONS

SOLUTION CONTROL SYSTEM

Solution Tank	-	60 Gallons (227 liter) Polyethylene
Solution Control	-	Variable to 3.0 GPM (11.4 lpm)
Type	-	Gravity Feed

OPTIONAL EQUIPMENT

Back-Up Alarm		Headlight/Taillights
Seat Belt		Strobe Light (Red or Amber)
ESP System		Overhead Guard
Pad Drivers		Squeegee Wand
Spray and Vac Wand Option		Fire Extinguisher
Linatex Squeegee		

DRIVES

Propulsion	-	Variable Displacement Pump-Hydraulic Motor
Sweeping	-	Hydraulic
Scrubbing	-	Hydraulic
Vacuum-Solution Pick-Up	-	Hydraulic
Sweeping	-	Hydraulic
Dust Control	-	Hydraulic

HYDRAULIC SYSTEM

Main Pump	-	Load Sense/Pressure-Compensated Variable Displacement
Reservoir	-	9.5 Gal (35.9 liter)
Control Valves	-	Electro Hydraulic with 10 Solenoids
Fluid	-	Mobil Multipurpose ATF or Equivalent Dexron III Fluid

SOLUTION RECOVERY SYSTEM

Vacuum Fan	-	Impellor, Hydraulic Drive
------------	---	---------------------------

RECOVERY TANK

-	78 Gallons (295 liter) Polyethylene
---	--

SQUEEGEE

Rear	-	Accu-Trac™ 40 in (101.6 cm) Swing, break away, Accu-Trac™ 46 in (116.8 cm) Swing, Break Away
Side	-	26 in (66 cm) Floating
Squeegee Material	-	Gum Rubber

SWEEPING SYSTEM

Type	-	Direct Throw
------	---	--------------

HOPPER

Capacity	-	2.5 cu.ft.(71 liter)
Weight Capacity	-	160 lbs (72 kg)

DUMP AND LIFT

Dump Height	-	14 in (35.6 cm.)
-------------	---	------------------

MAIN BROOM

One piece plastic core disposable type. Can be used for wet sweeping, free-float broom position.		
Length	-	36 in (91.4 cm)
Diameter	-	10 inches (25.4 cm)
Optional Bristle Type	-	Nylon (High density)
-	-	Proex
-	-	Nylon

SIDE BROOM

Side Broom Size - 16 inches (40.6 cm) Diameter

BRAKING SYSTEM

Dynamic - Hydraulic, Reverse of Drive Motor
Parking - Dual Disc Brakes, Mechanically Activated

ENGINE SYSTEM**Kubota WG972**

Type - Vertical, Water-Cooled, 3-Cylinder Gas Engine
Bore and Stroke - 2.93 in x 2.90 in (74.5mm x 73.6mm)
HP - 28 @ 3600 RPM
Oil Capacity Displacement - 58.7 cu in (962 cc)
Fuel - Standard Automotive Gasoline
Coolant - 50/50 Ethylen Glycol and Water

Kubota DF972

Type - Vertical, Water-Cooled 3-Cylinder LP Engine
Bore and Stroke - 2.93 in x 2.90 in (74.5mm x 73.6mm)
HP - 23.5 @ 3600 RPM
Oil Capacity Displacement - 58.7 cu in (962 cc)
Fuel - Liquid Propane Gas
Coolant - 50/50 Ethylen Glycol and Water

FUEL SYSTEM

Gas Tank - 10 gal (37.85 liter)
LPG Tank - 33 lbs (13.61kg)

PROPULSION SYSTEM

Type - Hydro-Mechanical
Control - Foot -Activated Pedal

MACHINE DIMENSIONS

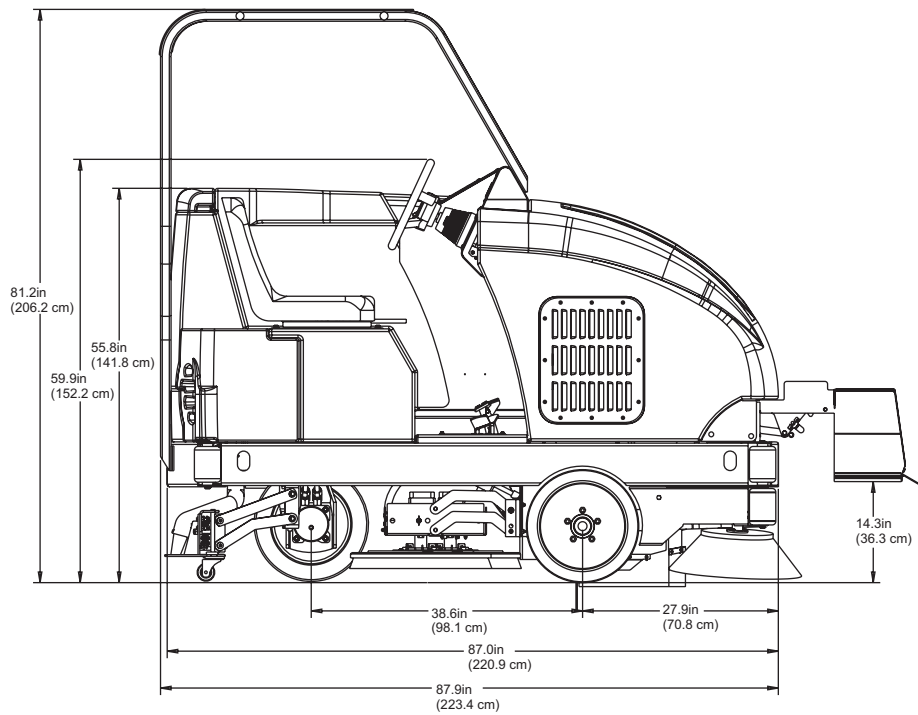
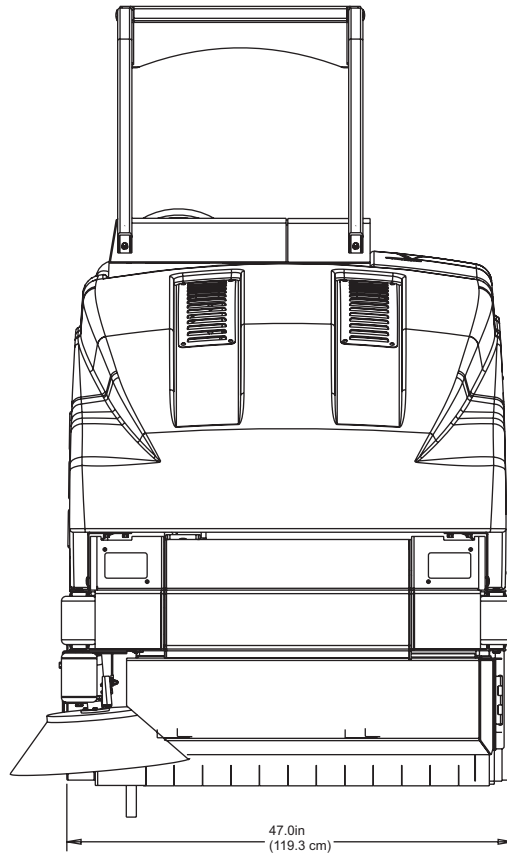



Figure 1

YOUR SC7740 MACHINE HAS BEEN SHIPPED COMPLETE, BUT DO NOT ATTEMPT TO OPERATE WITHOUT FOLLOWING THESE INSTRUCTIONS.

PREPARING THE MACHINE FOR OPERATION

1. Connect and tighten battery cables.
2. Fill the fuel tank with REGULAR GRADE gasoline (Gasoline Model) and Commercial Petroleum Gas (LP Model).



WARNING

Never fill the tank while the engine is running. Always be sure the gasoline container and sweeper are electrically connected before pouring gasoline. This can easily be done by providing an insulated wire (permanently attached to container) with a battery clip on the other end.

3. Check engine crankcase oil level. Although properly lubricated at the factory, check before starting the engine. No special break in oil is used; and recommended number of operating hours before the initial oil change is the same as normal. After the first 50 operating hours, service must be performed on your engine to ensure future high performance and trouble free operation. See Maintenance.
4. Check radiator coolant level. Permanent type antifreeze is added at the factory to provide protection to approximately -35°F (37°C). To retain this protection level, always add ½ part water to ½ part antifreeze.
5. Check fluid level in hydraulic reservoir which is located in the engine compartment. The hydraulic reservoir is full when fluid can be seen 1/3 of the way up in the sight glass on the front of the reservoir. To get an accurate reading the hopper must be in the "DOWN" position. If fluid is required add Mobil Multi Purpose ATS or equivalent Dexron III fluid only. Do not fill the reservoir more than 1/3 of the way up the sight glass. See Maintenance.

SAFETY INSTRUCTIONS

THE FOLLOWING STATEMENTS ARE USED THROUGHOUT THIS MANUAL AS INDICATED IN THEIR DESCRIPTIONS:

DANGER

To warn of immediate hazards which will result in severe personal injury or death.



WARNING

To warn of hazards or unsafe practices which could result in severe personal injury or death.



CAUTION

To warn of hazards or unsafe practices which could result in minor personal injury.

ATTENTION

To warn of unsafe practices which could result in extensive equipment damage.

NOTE

To give important information or to warn of unsafe practices which could result in equipment damage.



WARNING

THE FOLLOWING INFORMATION SIGNALS POTENTIALLY DANGEROUS CONDITIONS TO THE OPERATOR OR EQUIPMENT. READ THIS MANUAL CAREFULLY. KNOW WHEN THESE CONDITIONS CAN EXIST. THEN, TAKE NECESSARY STEPS TO TRAIN MACHINE OPERATING PERSONNEL. FOR THE SAFE OPERATION OF THIS MACHINE, READ AND UNDERSTAND ALL WARNINGS, CAUTIONS AND NOTES.



WARNING

Machines can ignite flammable materials and vapors. Do not use with or near flammables such as gasoline, grain dust, solvents, and thinners.



WARNING

Improper use of heavy machinery can cause personal injury.



WARNING

Operate only when lids, doors, and access panels are securely closed.



WARNING

Use care when reversing machine in confined area.



WARNING

When servicing the machine, disconnect the batteries first to prevent possible injury.



WARNING

When working on the machine, empty hopper, remove batteries, clear area of people and obstructions, use additional people and proper procedures when lifting the machine.



WARNING

Always empty the hopper and disconnect the battery before doing maintenance.



WARNING

You must have training in the operation of this machine before using it. READ THE INSTRUCTION BOOK.



WARNING

Do not operate this machine unless it is completely assembled.



WARNING

Do not use this machine as a step or furniture.



WARNING

Stop and leave this machine on a level surface. When you stop the machine, put the power switch in the "OFF" position and engage the Wheel Lock.

 **WARNING**

To prevent injury and damage to the machine, do not lift the machine or move it to an edge of a stair or loading dock.

 **WARNING**

Lead acid batteries generate gases which can cause an explosion. Keep sparks and flames away from batteries. **NO SMOKING.** Charge batteries only in areas with good ventilation.

 **WARNING**

Always wear eye protection and protective clothing when working near batteries. Remove all jewelry. Do not put tools or other metal objects across the battery terminals or across the tops of batteries.

 **WARNING**

Maintenance and repairs must be done by authorized personnel only. Tighten all fasteners. Maintain adjustments according to the specifications given in the service manual for the machine. Keep the electrical parts of the machine dry. For storage, keep the machine in a building.

 **WARNING**

Make sure all labels, decals, warnings, cautions and instructions are fastened to the machine. Purchase new labels and decals from American-Lincoln.

 **WARNING**

The operator must exhibit extreme caution when negotiating, turning, and traveling across grades or ramps. Start, stop, change direction, travel and brake smoothly. Slow down when turning.

 **WARNING**

Avoid uneven surfaces and loose materials. Watch for obstructions, especially overhead.

 **WARNING**

Operate only from the designated operator's position. Stay inside the body of the machine. Keep hands and feet on the designated controls. Always operate in well lighted areas.

 **WARNING**

Do not carry passengers on the machine. Set the Wheel Lock when leaving the machine. Chock (block) the wheels if the machine is parked on a grade (ramp), or is being prepared for Maintenance.

 **WARNING**

Never leave the operator's compartment when the is engine running.

 **WARNING**

Report damage or faulty operation immediately. Do not operate the machine until repairs have been completed. Maintenance and repairs must be done by authorized personnel only.

 **WARNING**

To maintain the stability of this machine in normal operation, the overhead guard, counterweights, roller bumper guards, or any similar equipment installed by the manufacturer as original equipment should never be removed. If it becomes necessary to remove such equipment for repair or maintenance, this equipment must be reinstalled before the machine is placed back into operation.

 **WARNING**

Electrical hazard. Shocks can cause serious personal injury. Unplug the battery before cleaning or servicing. To avoid possible injury or property damage, read the Operator's Manual before servicing the machine. Maintenance and repair must be done by authorized personnel.

 **WARNING**

Disconnecting the battery connector with the key switch in the "I" position will cause sparks that could ignite explosive hydrogen gas generated by the batteries. To prevent serious injury or possible property damage, turn Key Switch to "O" position before disconnecting the battery cable from the machine for charging or service.

SAFETY INSTRUCTIONS

FOR SAFETY, OBSERVE THE FOLLOWING WARNINGS. FAILURE TO COMPLY MAY CREATE A SERIOUS RISK OF INJURY TO YOU AND OTHERS. THIS MACHINE SHOULD NOT BE USED IN HAZARDOUS LOCATIONS INCLUDING AREAS OF VOLATILE DUST OR VAPOR CONCENTRATIONS.

Operators must be trained and qualified to operate this machine. They must also understand the operator's manual before starting.

Use caution when mounting or dismounting the machine particularly on wet slippery surfaces.

Do not dump the hopper over an open pit or dock. Do not dump the hopper when positioned on a grade (ramp). The machine must be level (horizontal).

LEFT SIDE CONSOLE

The left side console contains a set of nine (9) switches, a top bank of four (4) and a bottom bank of five (5). The console is completely fuse-driven.

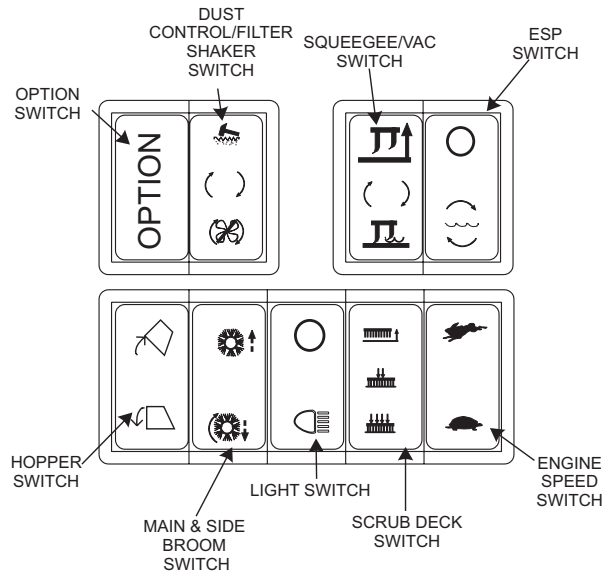

LIGHT SWITCH (OPTIONAL)

If installed the two-way light switch is located on the lefthand console in the bottom bank. By pressing on the lower part of the switch, various light options available for this machine are controlled. Pressing the upper portion of the switch turns off all light options.

DUST CONTROL/FILTER SHAKER SWITCH

The dust control/filter shaker switch is located on the left side console in the top bank. By pressing the top of the switch, the filter shaker motor is activated for approximately 20 seconds. The impeller fan will stop when the filter shaker has been activated. The filter shaker will only operate with the hopper in the “DOWN” position. If the switch is in the middle position, the dust control system automatically engages when the main broom is lowered and disengages when the broom is raised. Pressing the bottom of the switch turns the dust control system off completely, using a manual override. The dust control system should **NOT** be used if sweeping in wet conditions in order to avoid dust filter damage.

NOTE

The filter shaker will automatically run each time the broom is turned off and the DustControl is in Auto mode (switch is in middle position).

MAIN BROOM & SIDE BROOM SWITCH

The main & side broom switch is located on the left side console in the bottom bank. By pressing in the upper portion of the switch, the side and main broom are raised and turned off. To lower and turn on both brooms for normal (flat surface) sweeping, press the lower portion of the switch. If a “FLOAT” (uneven surface) position is desired, the brooms must be adjusted manually. (See Main & Side Broom Adjustment in this chapter.)

SCRUB DECK SWITCH

The three-way scrub deck switch is located on the left side console in the bottom bank. In the middle position, the scrub brush deck is lowered and the three brushes activated for normal scrubbing. To activate heavy-pressure scrubbing, press the lower portion of the switch. Pressing the upper portion of the switch stops brush rotation and raises the scrub deck.

NOTE

Lowering the scrub deck will not start the brushes rotating. The foot pedal must be moved to engage the scrub brushes. If the machine stops moving for 2 seconds or more, the brushes will automatically stop rotating until the machine starts moving again.

OPERATION OF CONTROLS AND GAUGES

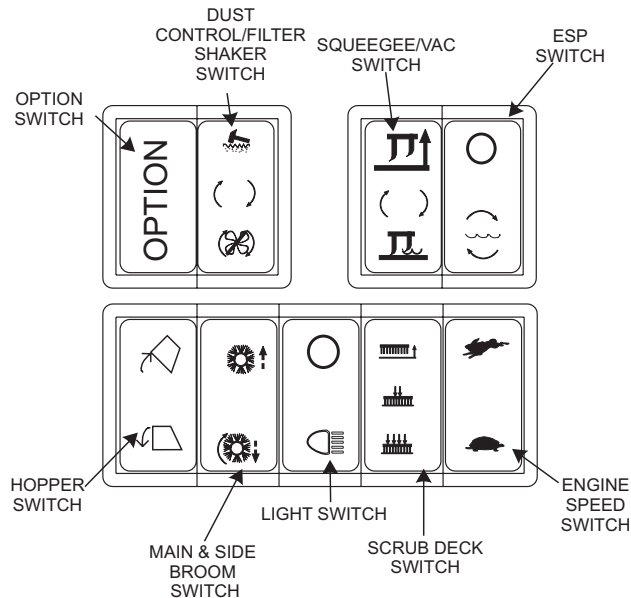

ENGINE SPEED SWITCH

This two-position switch, located on the left side console in the bottom bank, controls the engine. The switch position determines the governed operating speed of the engine. Place the speed switch in the “IDLE” position to start the machine. Place the speed switch in the “FAST” position for transport and during normal operation.

NOTE

The engine will NOT start unless the switch is in the “IDLE” position.

(The engine RPM in idle should be 1550 +/- 50. The engine RPM in fast with no load should be approximately 2750. The Engine RPM in fast fully loaded with all systems running should be 2600 +/- 50.)

SQUEEGEE/VAC SWITCH

The squeegee switch is located on left side console in the bottom bank. Pressing the upper portion of the switch raises the squeegee and turns off the squeegee vacuum system.

In the middle position, the squeegee and its vacuum system will operate automatically when the machine’s scrub deck is lowered. When the scrub deck is raised, the squeegee and vacuum system automatically shuts down. The vacuum functions on a 15-second delay, collecting the water remaining in the recovery hose. If the scrub deck is down and the machine is put in reverse (activated by the FWD/REV pedal), the squeegee will automatically raise, again with the vacuum on a 15-second delay. When the machine is once again placed in the forward position, the squeegee will lower and the vacuum automatically turns on.

In pressing the lower portion of the switch a manual override is engaged, allowing the squeegee and vacuum system to operate independent of the scrub deck. Again, if the machine is placed in reverse, the squeegee automatically raises and the vacuum system shuts off following a 15-second delay, resuming operation once the machine returns to its forward motion.

HOPPER SWITCH

The hopper switch is located on the left side console. The switch controls operation of the hopper. To dump debris from the hopper, press the upper portion of the switch and continue to hold until the hopper is fully open. To lower the hopper, press the lower portion of the switch and continue to hold until the hopper returns to the closed position.

ESP SWITCH (OPTION)

If installed the ESP switch is located in the left side console on the far right of the top bank. This switch is an open switch unless a machine option, such as a water recycling system, is ordered installed on the machine.

OPERATION OF CONTROLS AND GAUGES

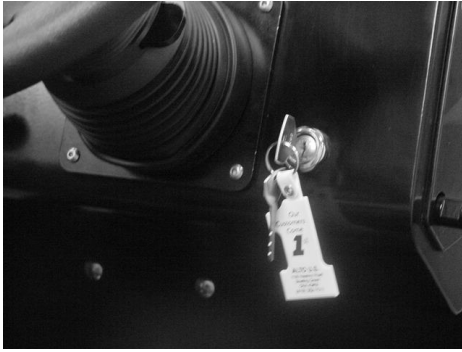

KEY SWITCH

The keyed ignition switch is located in the lower righthand corner of the instrument panel. The “OFF” position (O position) will shut off the engine. The “IGN/ON” position (I position) provides power to all machine systems and accessories. The “START” position (one position clockwise of I position) is momentary and provides power to the starter motor.

NOTE

To reengage, the key must be returned to the “OFF” position.



HOUR METER

The hour meter is located on the righthand side of the instrument panel next to the fuel gauge. The meter is activated when the key switch is placed in the ignition position. The meter indicates the actual “run” time of the machine. The meter can also be used to determine when maintenance should be done on the machine.



FUEL GAUGE/LP INDICATOR LIGHT

The fuel gauge or LP indicator light is located on the instrument panel to the left of the hour meter and indicates the level of fuel in the tank or low LP indicator light. The key switch powers the fuel gauge. The key switch must be in the “ON” position for the fuel gauge to work. The fuel gauge is not included on machines that use Liquid Propane fuel.

BACK-UP ALARM SWITCH (Option)

The back-up alarm is operated by a switch located under the lower section of the accelerator and directional control pedal. The alarm makes a loud audible noise when the machine is being driven in reverse.

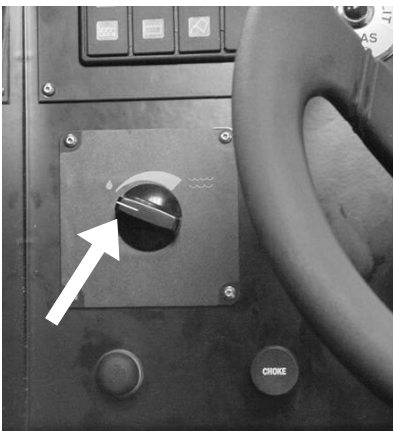

SOLUTION CONTROL KNOB

The solution control knob is located to the left hand side of the steering wheel below the indicator lights. Turning the knob clockwise will increase the flow of solution. Turning the knob counterclockwise will decrease the flow of the solution. To turn the solution off turn the knob all the way counterclockwise.

NOTE

For best results, discontinue application of solution 10 feet before stopping or making a 90° or 180° turn.

OPERATION OF CONTROLS AND GAUGES

WARNING BANK

The Warning Bank is located on the lefthand side of the instrument panel and provides the operator with eight fault/status indicators for engine, sweeping, and scrubbing systems. The operator should monitor the indicators whenever operating the SC7740. It is very important the operator be familiar with the meaning of each indicator.

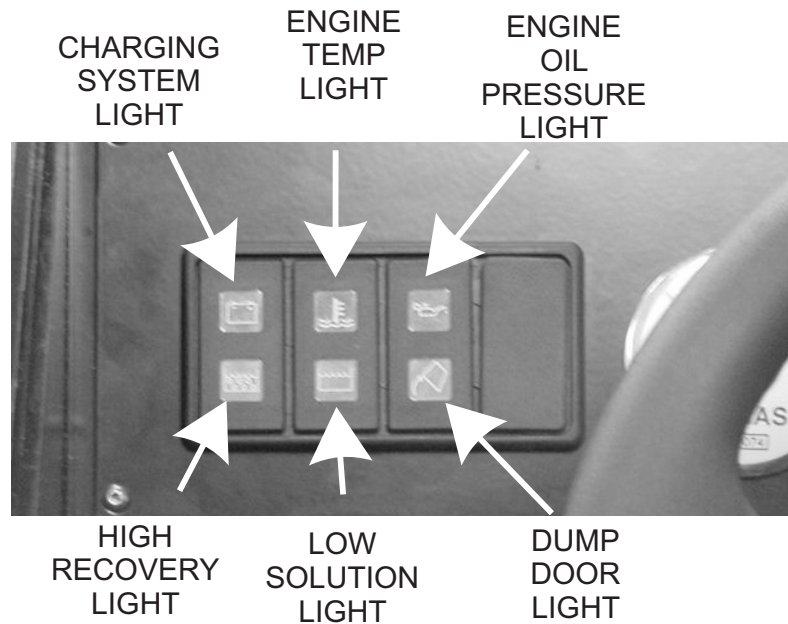

ENGINE TEMP LIGHT

The engine temperature light illuminates to indicate an engine cooling system fault. When this occurs, the operator must turnoff the SC7740 immediately and have the cooling system serviced by a qualified technician.

ENGINE OIL PRESSURE LIGHT

When the oil pressure drops below approximately 5 psi, an automatic protection circuit shuts down the engine and illuminates the light to indicate low oil pressure. When this occurs, have the SC7740 serviced by a qualified technician.

CHARGING SYSTEM LIGHT

The charging system (battery) light illuminates to indicate a charging system fault. When this occurs, the SC7740 charging system is not working properly and must be serviced by a qualified technician.

HIGH RECOVERY LIGHT

The recovery high warning light, located on the lefthand side of the instrument panel, will illuminate approximately 5 minutes before the recovery tank is full, giving ample time to complete the scrubbing cycle, before the mechanical float shuts off the vacuum to the recovery tank.

LOW SOLUTION LIGHT

The low solution warning light, located to the left of the high recovery light, will illuminate when the solution tank is empty and marks the end of the scrubbing cycle.

OPERATION OF CONTROLS AND GAUGES

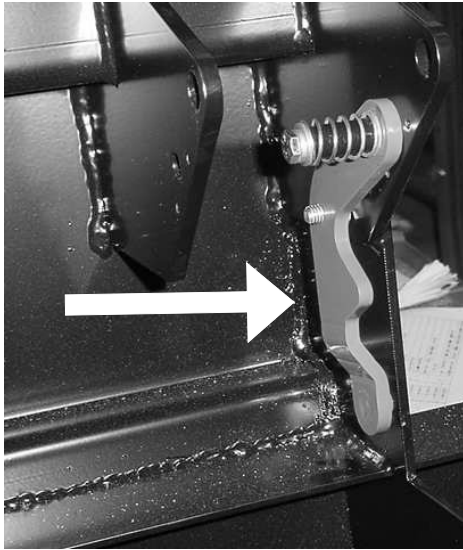

HOPPER SAFETY ARM

The hopper safety arm is located near the right front wheel well. The safety arms prevents the hopper from dropping unexpectedly during service/maintenance.

TO ENGAGE SAFETY ARM:

1. Raise hopper.
2. Set parking brake.
3. Lift safety arm to engage the slot on the hopper frame.
4. When work has been completed, replace the safety arm to the stowed position.



SEAT POSITION ADJUSTMENT

The seat position adjustment lever is located on the front of the seat to the left. The lever is spring-loaded to the "LOCK" position. To adjust the seat, push the lever to the "RIGHT" and move the seat to the desired position. Then release the lever to "LOCK" the seat into place.

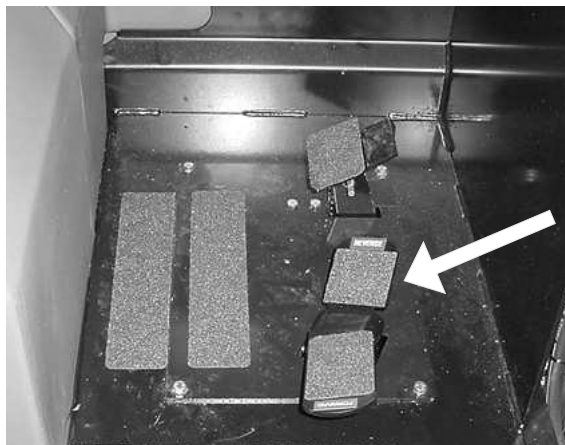

DIRECTIONAL CONTROL PEDAL

The Directional Control Pedal is located on the floor of the operator's area. This pedal controls the machine direction.

1. Apply foot pressure on the right side of the pedal to move the machine forward.
2. Increase foot pressure on the right side of the pedal to increase the forward speed.
3. Apply foot pressure on the left side of the pedal to move the machine in reverse.
4. Increase the pressure on the left side of the pedal to increase the reverse speed.

The Directional Control Pedal also controls the dynamic braking of the machine.

1. To stop the machine, allow the directional control pedal to return to the neutral (center) position. The pedal will automatically return to the neutral position when the foot pedal is released, or when light foot pressure is applied on the opposite side of the pedal. If the machine is moving forward, put light foot pressure on the left side of the pedal. If the machine is moving in reverse, put light foot pressure on the right side of the pedal.

OPERATION OF CONTROLS AND GAUGES

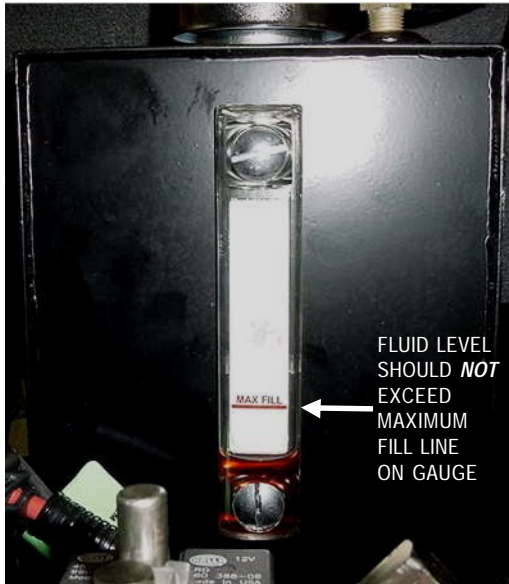

HYDRAULIC RESERVOIR LEVEL SIGHT GAUGE

The sight gauge is located on the front of the secondary hydraulic reservoir. The sight gauge is used to indicate the level of fluid in the reservoir. The fluid level must be visible in the sight gauge when the hopper is in the down position.

WARNING!

Hydraulic fluid level on the remote reservoir should **NOT** exceed the **FILL LINE** on the sight gauge. Allowance must be made for fluid expansion/overflow.

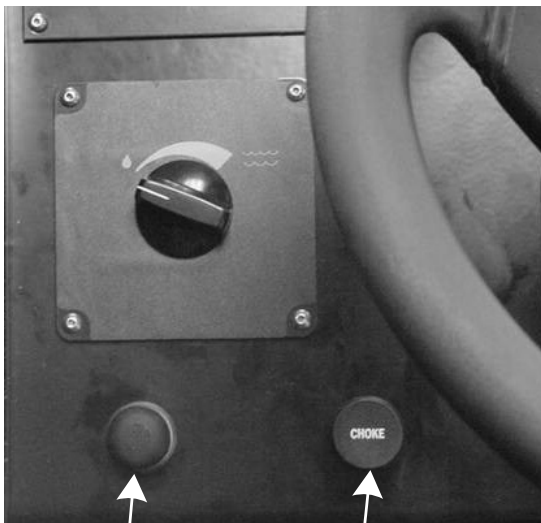

HORN BUTTON

The horn button is located on the instrument panel in the lower lefthand corner. The horn button is always active.

CHOKE

The choke control is located on the instrument panel to the right of the horn button and is used to aid in starting the engine. The choke governs the mixture of air and fuel during the combustion cycle of engine operation. The choke should be pulled while starting the engine and then gradually pushed in after the engine warms up.

- To turn on the choke for "COLD" starting, pull out the knob marked choke.
- To turn off choke once the engine running, gradually push in the control knob.

HORN

CHOKE

BEFORE STARTING THE ENGINE

1. Set parking brake.
2. Make sure all controls are in the "OFF" position.
3. Be sure the directional control pedal is in neutral.

NOTE

Before starting the engine, perform the pre-start checklist.

PRE-START CHECKLIST

1. Clean engine air filter element.
2. Check engine oil level.
3. Check radiator coolant level.
4. Check hydraulic fluid level.
5. Check fuel level.
6. Check all systems for leaks.
7. Check brakes and controls for proper operation.
8. Check that main and side brooms are free of debris which might inhibit rotation and pick-up.
NOTE: Always wear hand protection when cleaning debris from brooms and/or brushes.
9. Check to ensure all covers, panels, and access doors are securely closed.

NOTE

To prevent possible fire, never fill fuel tank while the engine is running. Always be sure gasoline container and machine are grounded before dispensing gas. This can be done by permanently attaching an insulated wire with a battery clip on the end to the gasoline container.



WARNING

When the machine has been stored in below-freezing temperatures, run the engine at no more than 1/2 throttle with the machine standing still for 5-10 minutes to warm the engine and hydraulic oil.

STARTING GAS ENGINES

Use the choke in extremely cold temperatures, (under 32°F or 0°C).

1. Pull choke if needed.
2. Set the engine speed control to idle setting.
3. Turn key to "START" position until engine starts, then release. (The key switch will return to the "I" position).
4. Push in the choke after engine starts running (if used).

STARTING LP ENGINES

Perform these checks in addition to the pre-start checklist:

1. Check connections for leaks.
2. Open the LP storage tank valve.
3. Check the regulator. Momentarily press the fuel primer on the regulator cover to bleed air out of the system.
4. Set the engine speed control to the "IDLE" (low) speed setting.
5. Turn key to "START" until engine starts, then release (key switch will return to the "I" position).

POST-OPERATION CHECKLIST

1. Clean the debris hopper.
2. Check sweeping brooms for wear or damage.
3. Check all squeegees and flaps for wear, damage, and any needed adjustment.
4. Fill the fuel tank.
5. Check all systems for leaks.
6. Close the LP storage tank valve (LP powered machines only).

HELPFUL HINTS FOR CLEANING OPERATION

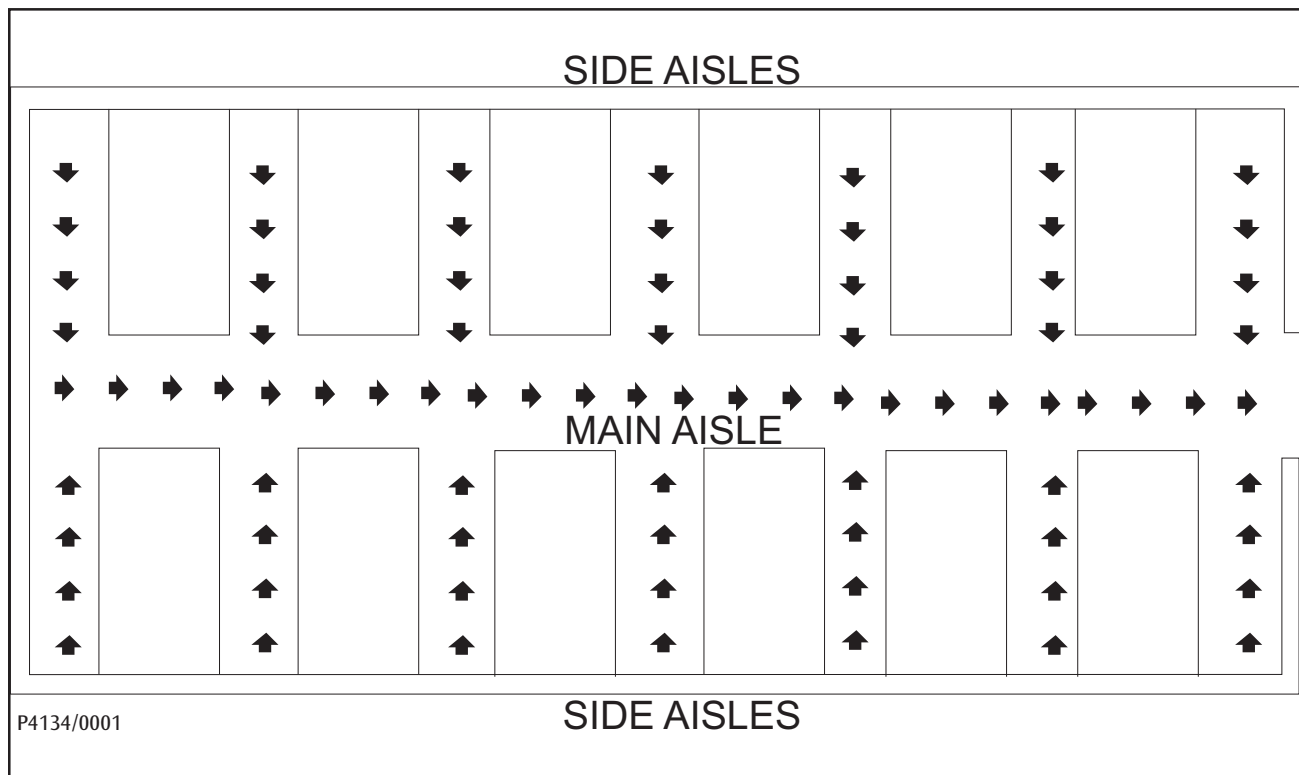

WARNING

Do not turn the steering wheel sharply when the machine is in motion. The machine is very responsive to movement of the steering wheel. Do not make sudden turns. Scrub in straight paths. Do not bump posts. Do not scrape the sides of the machine.

1. Plan your sweeping and scrubbing in advance. Try to arrange long runs with minimum stopping and starting. Sweep debris from narrow aisles out into main aisles ahead of time. Do an entire floor or section at one time.
2. Pick up oversize debris before sweeping.
3. Allow a few inches of overlap of sweep and scrub paths. This will eliminate leaving dirty patches.
4. Do not turn steering wheel too sharply when the machine is in motion. The machine is very responsive to movement of the steering wheel, so avoid sudden turns.
5. Try to follow as straight a path as possible. Avoid bumping into posts or scraping the sides of the machine.
6. Always allow the machine to warm up before operating in cold temperatures.
7. Periodically turn the sweeping broom end-over-end to prevent the bristles from “setting” in one direction.

NOTE

Replace the sweeping broom when the bristles are worn to 3 inch (8 cm) length. Replace disc brushes when bristles are reduced to ½ inch (1.3 cm) in length. Replace squeegee rubbers when all usable edges have become rounded with wear, impairing the wiping action.

ESP SYSTEM OPERATING INSTRUCTIONS

THE SCRUBBING SYSTEM - HOW IT WORKS

There are two scrubbing systems available for the SC7740 machine, the non-recycling or standard scrubbing system and the recycling or ESP scrubbing system.

THE NON-RECYCLING OR STANDARD SCRUBBING SYSTEM - HOW IT WORKS

During the scrubbing process, detergent solution water from the solution tank is fed to the solution line. There it is fed to the floor where two or three disc scrubbing brushes work to dislodge soil. After scrubbing, the dirty solution is vacuumed from the floor and discharged into the recovery tank.

Sensors in each tank will indicate, by lights on the control panel, when the water in the solution tank is too low or when the water in the recovery tank is too high.

THE ESP RECYCLING SYSTEM ON/OFF SWITCH (Option)

This switch turns the ESP recycling system on and off.

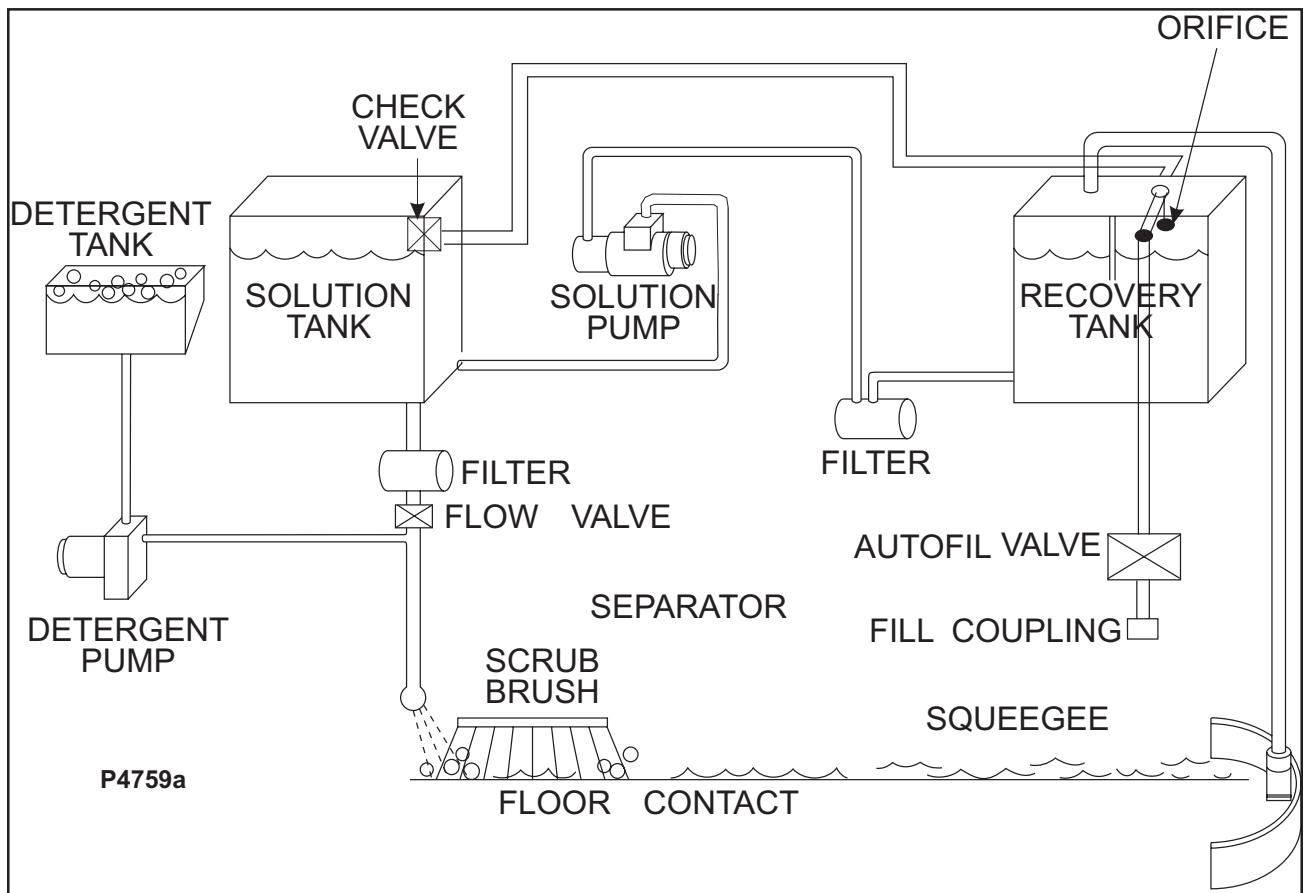

NOTE

The solution control lever must be on "FULL" for ESP operation.

THE RECOVERY OR ESP SYSTEM - HOW IT WORKS

During the scrubbing process, filtered water from the solution tank is fed to the solution line, where it combines with detergent. This mixture is then fed to the floor where two or three disc scrubbing brushes work to dislodge soil. After scrubbing, the dirty solution is vacuumed from the floor and discharged into the recovery tank. At intervals, a float switch activates the recycling pump, which sends filtered solution from the recovery tank to the solution tank.

ORDERING PARTS

Parts may be ordered from American-Lincoln authorized distributors. Record the information from the American-Lincoln serial number plate to avoid delays in filling your order.

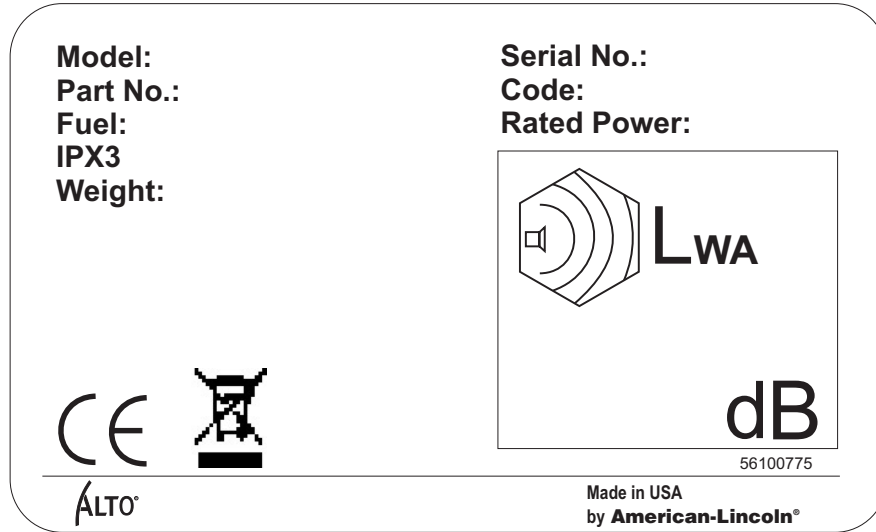

1. Use the model number, catalog number, and serial number when ordering.
2. Give the part number, description, and quantity of parts needed.
3. Give shipping instructions for either freight, UPS, or parcel post.

Parts and supplies listed in this manual can be ordered from the following address:

<p>Nilfisk-Advance, Inc. American-Lincoln Div.</p>	<p>American-Lincoln authorized distributor</p>
<p>14600 21st Avenue North Plymouth, MN 55447 1-800-214-7700</p>	

MACHINE CATALOG NUMBERS

- 505-312 SC7740 Gas Sweeper/Scrubber 40"
- 505-313 SC7740 LP Sweeper/Scrubber 40"
- 505-314 SC7740 Gas Sweeper/Scrubber 46"
- 505-315 SC7740 LP Sweeper/Scrubber 46"
