

OILGEAR TYPE “PVWC” PUMPS - -011/-014/-022 SERVICE INSTRUCTIONS

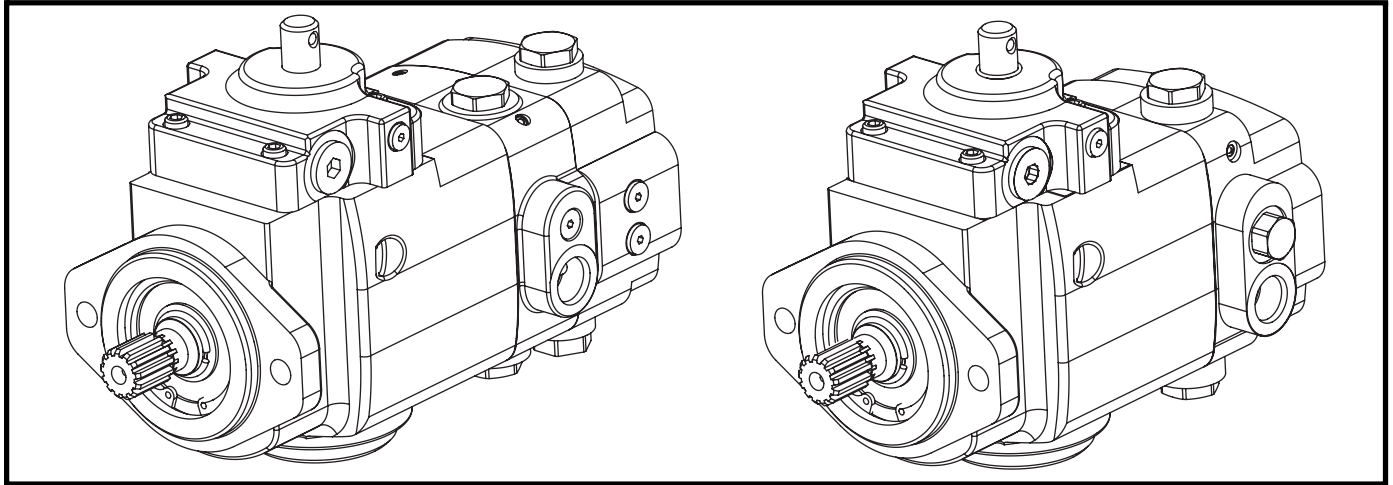

Figure 1. Typical Oilgear “PVWC” Close Loop, Hydrostatic Pump

PURPOSE OF INSTRUCTIONS

These instructions will simplify the installation, operation, maintenance and troubleshooting of Oilgear type “PVWC” pumps.

Become familiar with the construction, principle of operation and characteristics of your pump to help you attain satisfactory performance, reduce shut-down and increase the pump's service life. Some pumps have been modified from those described in this bulletin and other changes may be made without notice.

NOTE

If the characters of your pump's type designation, following the second dash (-) are “A1” or “B1”, refer to Bulletin 947018 for applicable instructions.

Due to design upgrades for series A1, A2, A3, B1, B2 and B3, most parts are no longer available. Refer to **Service Kits** for applicable design series.

REFERENCE MATERIAL

Fluid Recommendations	Bulletin 90000
Contamination Evaluation Guide.....	Bulletin 90004
Filtration Recommendations	Bulletin 90007
Piping Information	Bulletin 90011
Installation of Vertically Mounted Axial Piston Units	Bulletin 90014
PVWC Hydrostatic (Closed Loop) Pump, Sales	Bulletin 47018-B
MN & MS Lever Control	Bulletin 947116
Electronic VS Servo Valve Control.....	Bulletin 947717

Safety First

Read and understand this entire instruction sheet before repairing, or adjusting your Oilgear product.

Those who use and maintain this equipment must be thoroughly trained and familiar with the product. If incorrectly used or maintained, this product and its equipment can cause severe injury.

SAFETY SYMBOLS

The following signal words are used in this instruction sheet to identify areas of concern where your safety may be involved. Carefully read the text and observe any instructions provided to ensure your safety.

DANGER

THIS SIGNAL WORD INDICATES AN IMMEDIATELY HAZARDOUS SITUATION WHICH, IF NOT AVOIDED, WILL RESULT IN DEATH OR SERIOUS INJURY.

WARNING

This signal word indicates a potentially hazardous situation which, if not avoided, could result in death or serious injury.

CAUTION

This signal word indicates that a potentially hazardous situation exists which, if not avoided, may result in damage to equipment or minor personal injury.

NOTE

While not directly relevant to the topic being discussed, the NOTE is used to emphasize information provided, or provide additional information which may be of benefit.

WARNING

This service information is designed for the maintenance of your Oilgear product. It contains the information on the correct procedures determined by Oilgear for the safe manner of servicing. Always keep this instruction sheet in a location where it is readily available for the persons who use and maintain the product. Additional copies of this instruction sheet are available through the Oilgear Company. Or visit our website: www.oilgear.com. Please contact us if you have any questions regarding the information in this instruction bulletin.

NOTE

The cleanliness of working on this pump or the hydraulic system is extremely important to the safety and reliability of the pump and the system. Always make sure the fittings are clean on the outside before removing them from their connections, are capped and plugged when removed and placed in a clean rag or container until they are reinstalled.

WARNING

Some service operations may require special tools or equipment. If you require information on these items, please contact Oilgear before attempting these repairs and service operations.

WARNING

Read, understand, and follow the safety guidelines, dangers, and warnings contained in this instruction sheet to promote reliable operation and prevent serious personal injury.

WARNING

DO NOT attempt to service this machinery in an environment where safety regulations are not established and in place.

WARNING

DO NOT operate the hydraulic system if a leak is present. Serious injury may result.

WARNING

Hydraulic systems operate under very high pressure. Hydraulic fluid escaping from a pressurized system can penetrate unprotected body tissue. DO NOT inspect for hydraulic leaks with bare hands or other exposed body parts. As a minimum, wear leather gloves prior to inspecting for leaks and use cardboard or wood. If leaks are present, relieve pressure and allow system to cool prior to servicing. If injured by escaping hydraulic oil, contact a physician immediately. Serious complications may arise if not treated immediately. If you have questions regarding inspecting for hydraulic leaks, please contact Oilgear prior to servicing.

⚠ WARNING

Hydraulic hoses and tubing must be inspected on a daily basis for leaks, cuts, abrasions, damage and improper clearance along any mounting frame for hidden damage before the unit is put into service. Replace damaged hoses or hoses you suspect are damaged before the system is returned to service! Hoses must be replaced every two years. Failure to properly inspect and maintain the system may result in serious injury.

⚠ WARNING

Hydraulic systems are hot. **DO NOT TOUCH!** Serious personal injury may result from hot oil. When you have completed working on the hydraulic system, thoroughly clean any spilled oil from the equipment. Do not spill any hydraulic fluids on the ground. Clean any hydraulic fluids from your skin as soon as you have completed maintenance and repairs. Dispose of used oil and system filters as required by law.

⚠ WARNING

Use correct hoses, fittings, and adapters with the correct SAE rating when replacing hoses to prevent possible serious injury. Always replace hoses, fittings, and adapters with replacements that have a proper, suitable, working pressure rating. Replacement hoses must be of the correct length and must comply with the hose manufacturer's and Oilgear's installation guidelines and recommendations.

⚠ WARNING

Hydraulic hoses have the SAE ratings marked on the hose to assist you in selecting the correct hose. The same manufacturer must supply any replacement hydraulic hoses and fitting assemblies. As an example: Brand "X" hose and brand "Y" fitting will not normally be compatible. No "Twist" is allowed in the hydraulic hoses. "Twist" may result in premature hose failure. This can cause serious injury. Please contact Oilgear for assistance when required.

⚠ WARNING

Hydraulic cylinders can be holding a function in a certain position when the pump is OFF. An example of this is a function being held in the lift or partial lift position by the cylinders. If a hydraulic line is removed or the hydraulic circuits or controls are being worked on, gravity may allow the function being held in position to drop. All workers and personnel must remain clear of these areas when working on or operating the hydraulic system. Block and secure all devices and functions which apply before beginning work or operation. Failure to comply with this can result in serious injury or death.

⚠ WARNING

Any hydraulic pipe which is replaced must conform to SAE J1065 specifications. If incorrect hydraulic pipe is installed, the hydraulic system may fail, causing serious injury. Damaged or leaking fittings, pipes or hoses must be replaced before the system is returned to service.

⚠ WARNING

DO NOT heat hydraulic pipe. The carbon content of this steel tube is such that if heated for bending, and either water or air quenched, the pipe may lose its ductility and thereby be subject to failure under high pressure or hydraulic chock conditions. Serious injury can result. Damaged or leaking pipes must be replaced before the system is returned to service. Please contact Oilgear if you require assistance or have questions.

⚠ WARNING

All hydraulic pressure must be relieved from the hydraulic system prior to removing any components from the system. To relieve the hydraulic pressure from the hydraulic system, turn off the motor and operate the control panel with the key in the ON position. Failure to comply can result in serious injury. If you have any questions concerning relieving the hydraulic pressure from the system, please contact Oilgear.

WARNING

Hydraulic components can be heavy. Use caution while lifting these components. Serious personal injury can be avoided with proper handling of the components.

WARNING

Please contact Oilgear if you require assistance, when performing hydraulic test procedures, use the proper hydraulic gauges. Installing an incorrect test gauge could result in serious injury if the gauge fails. Use properly rated hydraulic hoses to allow the test gauge to be read away from moving parts and functions.

WARNING

Increasing hydraulic pressure beyond the recommendations may result in serious damage to the pump and system or serious personal injury and may void the Oilgear Warranty. If you have questions concerning hydraulic pressures or testing procedures, please contact Oilgear before attempting the test procedures or making adjustments.

WARNING

An Oilgear pump must not be modified in any way without authorization from Oilgear. Modifications may not comply with safety standards, including ANSI safety standards, and may result in serious personal injury. Please contact Oilgear if you require assistance.

WARNING

DO NOT enter under hydraulic supported equipment unless they are fully supported or blocked. Failure to follow this procedure can result in serious injury or death.

WARNING

Any Oilgear pump safety decals must be replaced anytime they are damaged, missing, or cannot be read clearly. Failure to have proper decals in place can result in serious injury or death. (If you require safety decals, please contact Oilgear for replacement safety decals, at no charge.)

WARNING

Be sure everyone is clear of the area around the hydraulic system before operating after servicing. Remain attentive at all times when operating to check your work until you are completely sure it is safe to return to service. Failure to heed this warning may result in serious personal injury or death.

WARNING

Wear the proper protective clothing when operating, servicing or maintaining the hydraulic system or the Oilgear pump. Wear the correct protective gear, safety glasses, gloves, and safety shoes. Serious injury can result without proper protective gear.

WARNING

Make sure to keep hands and feet and other parts of your body clear of revolving or moving parts. Failure to comply can cause serious injury.

WARNING

DO NOT wear watches, rings, or jewelry while working with electrical and mechanical equipment. These items can be hazardous and can cause serious and painful injuries if they come into contact with electrical wires, moving parts, or hydraulic equipment.

PREPARATION AND INSTALLATION

MOUNTING

Pump Without Reservoir - The pump can be mounted in any position. But, the recommended mounting position is with the driveshaft on a horizontal plane and with the case drain "Port 1" on the top side. Secure the pump to a rigid mounting surface. Refer to **Piping and Fittings**.

Pump With Reservoir - These pumps are usually fully piped and equipped. Mount reservoir on level foundation with the reservoir bottom at least six inches above floor level to facilitate fluid changes.

PIPING AND FITTINGS

Refer to the referenced "Oilgear Piping Information" Bulletin 90011 and individual circuit diagram before connecting the pump to the system. Inlet velocity must not exceed 5 fps (1,5 mps). Inlet should be unrestricted and have a minimum of fittings.

NOTE

DO NOT use an inlet strainer.

The charge pump inlet must be unrestricted and have minimal fittings. It must reach within 1 to 2 times its diameter from the bottom of reservoir. **DO NOT "bottom-out" tubes in reservoir.**

Arrange case drain line so the case remains full of fluid (non-siphoning) at less than 25 psi (1,7 bar). Each drain line must be separate, unrestricted, full sized and connect directly to reservoir below the lowest fluid level. Drain tubing **MUST NOT** incorporate a "suction break." Provisions must be made for opening this line without draining (siphoning) reservoir.

WARNING

The pump is protected against overloads by built in relief valves but additional system high pressure relief valves may be required by your system. Install bleed valves at highest points in system. Use Oilgear automatic bleed valves. Contact your Oilgear Representative.

POWER

Power is required in proportion to volume and pressure used. Motor size recommendations for specific applications can be obtained from The Oilgear Company. Standard low starting torque motors are suitable for most applications.

CAUTION

DO NOT start or stop unit under load unless system is approved by Oilgear. It may be necessary to provide delivery bypass in some circuits.

DRIVE

Verify rotation direction plate on the pump's housing. Clockwise pumps must be driven clockwise and counterclockwise pumps must be driven counterclockwise. Use direct drive coupling. Size and install coupling per manufacturer's instructions.

CAUTION

DO NOT drive the coupling onto the pump driveshaft. If it is too tight, it may be necessary to heat coupling for installation. Refer to manufacturer's instructions.

Misalignment of pump shaft to driver's shaft should not exceed 0.005 inches (0,13 mm) Total Indicator Readout (TIR) in any plane.

FILTRATION

Keep the fluid clean at all times to ensure long life from your hydraulic system. Refer to the referenced "Oilgear Filtration Recommendations" bulletin 90007 and "Oilgear Contamination Evaluation Guide" Bulletin 90004. Oilgear recommends use of a filter in the pressure or return line. Replace filter element(s) when the filter condition indicator reaches change area at normal fluid temperature. Drain and thoroughly clean filter case. Use replacement element(s) of same beta 10 ratio (normally a ratio of 4 with hydraulic oils).

FLUID COOLING

When the pump is operated continuously at the rated pressure or frequently at peak load, auxiliary cooling of the fluid may be necessary. Fluid temperature should not exceed limits specified in the referenced Oilgear Fluid Recommendations Bulletin 90000.

AIR BREATHER

On most installations, an air breather is mounted on top of fluid reservoir. It is important for the breather to be the adequate size to allow air flow in and out of reservoir as fluid level changes. Keep the breather case filled to the "fluid level" mark. About once every six months, remove cover, wash screen in solvent and allow screen to dry, clean and refill case to level mark and install screen. Refer to the manufacturer's recommendations.

FLUID, FILLING AND STARTING RECOMMENDATIONS

Use **150-300 SSU VISCOSITY FLUID**, at 100°F (37,7°C) meeting or exceeding lubricating specifications of SAE 10W AP1 Engine Service Classifications - SC, CC or SE (or ISO VG32 through 68).

Refer to instruction plate on the unit, reservoir, machine and/or reference, Fluid Recommendations bulletin. Fire resistant fluids and phosphate ester fluids can be used in accordance with fluid manufacturer's recommendations.

1. Pump all fluid into reservoir through a clean (beta 10 ratio of 4 or more) filter. Fill reservoir to, but not above, "high level" mark on the sight gauge.
2. **Remove case drain line and fill pump case with hydraulic fluid.**

3. Turn driveshaft a few times by hand with a spanner wrench to make sure parts rotate.

Unit	-011/-014/-022
Approximate torque to turn driveshaft	15-30 in•lb (1.7-3.4 N•m)

Table 1. Torque to Turn Shaft

With pump under "no load" or with pump control at NEUTRAL:

4. Turn drive unit ON and OFF several times before allowing pump to reach full speed. The system can usually be filled by running the pump and operating the control.
5. The fluid level in the reservoir should decrease. Stop the pump. **DO NOT** allow the fluid level to go beyond the "low level." If the level reaches "low level" mark, add fluid and repeat step.

NOTE

With differential (cylinder) systems, the fluid must not be above "high level" when the ram is retracted or below "low level" when extended. Bleed air from the system by loosening connections or opening petcocks at the highest point in the system. Close connections or petcocks tightly when solid stream of fluid appears.

Use Oilgear automatic bleed valves or bleed air from the highest point in the system. Follow all the warning information when opening air bleed petcocks. Close connections or petcocks tightly when solid stream of fluid appears.

CAUTION

Fluid can be under high pressure. Use caution and follow all the warning procedures to prevent stream from hitting personnel or other machinery.

CONSTRUCTION

See **Figures 2 and 13**.

NOTE

Numbers in parentheses represent item number in parts list and drawings.

1. A drive shaft **(1)** runs through the centerline of pump housing **(5)**, rotating group, valve plate **(51)** and splined coupling **(62)**.
2. A front drive shaft bearing **(3)** supports the outboard end of the drive shaft and the inboard end is inserted into a splined coupling **(62)**. The charge pump is supported via the splined coupling by coupling bushing **(55)** in the Gerotor housing **(68)**.
3. The pump cylinder barrel **(18)** is carried in a journal type hydrodynamic cylinder bearing **(12)**.
4. The valve plate **(51)** has two crescent shaped ports. Pumping piston/shoe assemblies **(15)** in the cylinder are held against a swashblock **(11)** by a shoe retainer **(14)**.
5. The shoe retainer is held in position by a fulcrum ball **(16)** which is forced outward by a shoe retainer spring **(17)**.
6. The spring acts against the pump cylinder forcing it against the valve plate **(51)** while also forcing the piston shoes against the swashblock **(11)**.
7. The semi-cylinder shaped swashblock limits piston stroke and can be swiveled in arc shaped saddle bearings **(10A and 10B)** fitted (located) into the pump housing **(5)**.
8. The swashblock is swiveled by a control (covered in referenced material).
9. Non-adjustable high pressure relief valves and check valves **(54)** for **Ports A** and **Port B** are installed in the valve plate **(51)**.

The charge pump **(64)** is a generated rotor (Gerotor) design which is spline coupled **(62)** to the inboard end of the drive shaft. Relief valve assemblies for implement pressure **(69)** and charge pressure **(71)** are of the non-adjustable poppet type and are installed in the Gerotor housing **(68)**.

SPECIFICATIONS

NOTE

Refer to reference material, pump control material and individual application circuit for exceptions. All dimensions are approximate. For detailed information, contact your Oilgear Representative. Refer to **Tables 4A through 4D on pages 9 and 10.**

	Pump Model		
	PVWC-011	PVWC-014	PVWC-022
Maximum Piston Pump Displacement	0.66 cipr 10,8 cc/rev	0.86 cipr 14,1 cc/rev	1.35 cipr 22,1 cc/rev
Operating Pressure			
Rated Continuous	4000 psi (275 bar)	4000 psi (275 bar)	3000 psi (206 bar)
Maximum Intermittent (10% of duty)	4500 psi (310 bar)	4500 psi (310 bar)	3500 psi (241 bar)
Peak	5000 psi (350 bar)	5000 psi (350 bar)	5000 psi (350 bar)
Output Flow (@ 1800 rpm & Rated Cont Pressure)	4.1 gpm (15.5 lpm)	5.4 gpm (20.4 lpm)	8.5 gpm (32.2 lpm)
Input Shaft Speed			
Minimum	600 rpm	600 rpm	600 rpm
Continuous	3600 rpm	3600 rpm	3600 rpm
Intermittent	4000 rpm	4000 rpm	4000 rpm
Charge Pressure (@ 1800 rpm)			
Standard (Others Available)	75 psi (5 bar)	75 psi (5 bar)	75 psi (5 bar)
Minimum	30 psi (2 bar)	30 psi (2 bar)	30 psi (2 bar)
Case Pressure			
Maximum Continuous	15 psi (1 bar)	15 psi (1 bar)	15 psi (1 bar)
Maximum Intermittent	100 psi (7 bar)	100 psi (7 bar)	100 psi (7 bar)
Hydraulic Fluid Temp (@ pump inlet)			
Minimum	-40°F (-40°C)	-40°F (-40°C)	-40°F (-40°C)
Maximum	200°F (93°C)	200°F (93°C)	200°F (93°C)
Charge Pump Displacement (Optional)	.425 cipr (7 cc/rev) or .64 cipr (10.5 cc/rev)		
Operating Pressure			
Rated Continuous	1000 psi (69 bar)		
Maximum Intermittent (10% of duty)	1450 psi (100 bar)		

Table 2. Specifications. All data is for ISO 46 mineral-based oil at 125°F (160 SSU).

Unit	-011/-014/-022
Maximum torque of front unit	1290 in•lb (145,8 N•m)

Table 3. Maximum Allowable Input Shaft Torque

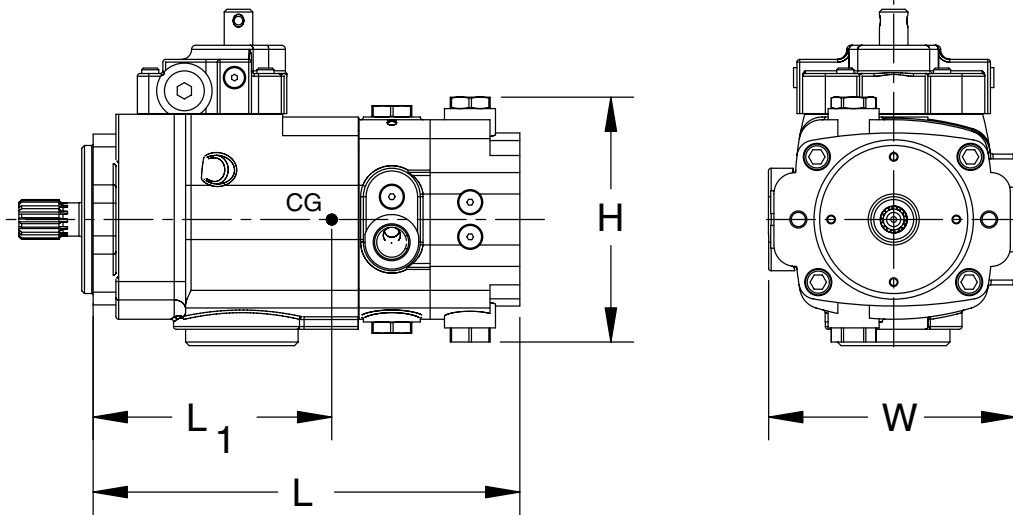

OILG0177

Pump Mount	Charge Pump	Length in. (mm)	Height in. (mm)	Width in. (mm)	Weight* lbs (kg)	L ₁ in. (mm)
A	0.425 CIPR	9.4 (238,8)	5.4 (137,2)	5.2 (132,1)	38.0 (17,3)	4.7 (119)
A	0.64 CIPR	9.6 (243,8)	5.4 (137,2)	5.2 (132,1)	38.7 (17,6)	4.8 (122)
B	0.425 CIPR	9.4 (238,8)	5.4 (137,2)	5.2 (132,1)	41.2 (18,7)	4.5 (114)
B	0.64 CIPR	9.6 (243,8)	5.4 (137,2)	5.2 (132,1)	41.9 (19,0)	4.6 (117)

* Weights are for MN/MS controls. Add 2.4 lbs (1,1 kg) for CA control or 11.0 lbs (5 kg) for VS and VM controls.

Table 4-A. Single Unit with Integral Charge Pump.

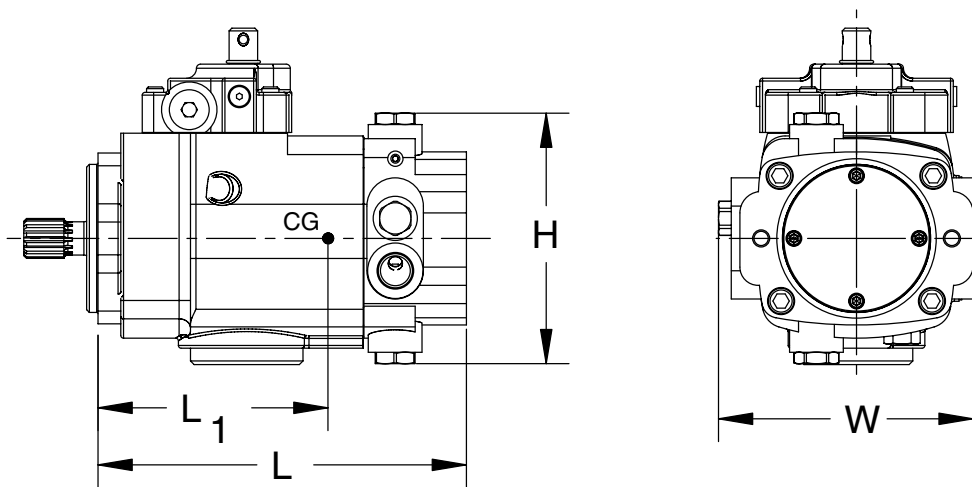

OILG178

Pump Mount	Length in. (mm)	Height in. (mm)	Width in. (mm)	Weight* lbs (kg)	L ₁ in. (mm)
SAE "A"	7.1 (180,3)	5.4 (137,2)	5.2 (132,1)	33.4 (15,2)	3.9 (99,1)
SAE "B"	7.1 (180,3)	5.4 (137,2)	5.2 (132,1)	36.6 (16,6)	3.7 (94,0)

* Weights are for MN/MS controls. Add 2.4 lbs (1,1 kg) for CA control or 11.0 lbs (5 kg) for VS and VM controls.

Table 4-B. Single Unit without Charge Pump.

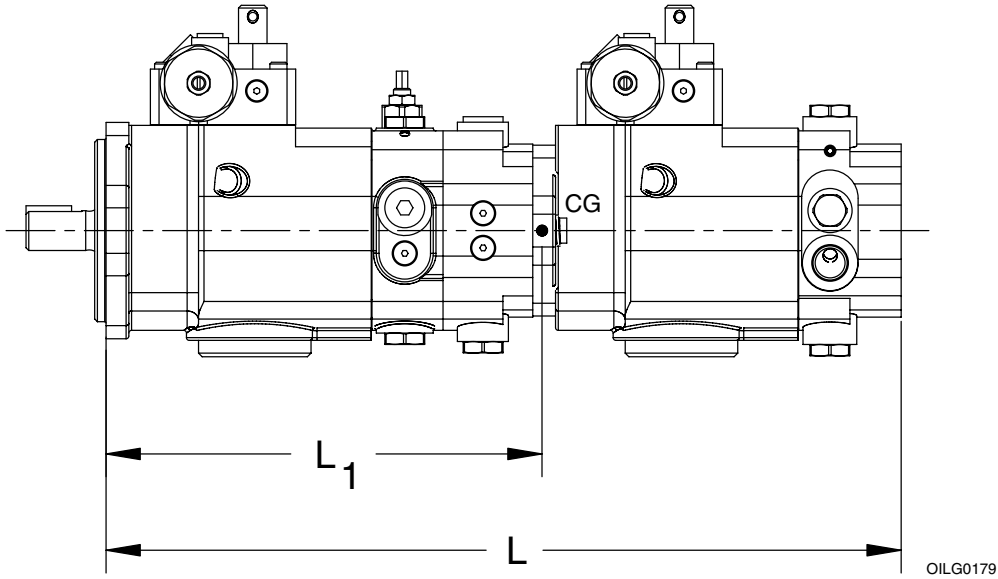

Front Pump Mount	Length* in. (mm)	Weight* lbs (kg)	L ₁ * in. (mm)
SAE "A"	16.5 (419,1)	71.4 (32,5)	8.7 (221,6)
SAE "B"	16.5 (419,1)	74.6 (33,9)	8.4 (213,4)

* Length and weights are for the 0.425 CIPR charge pump. Add 0.2 in. (5 mm) to length and 0.7 lbs (0,3 kg) to weight for 0.64 CIPR charge pump.

Table 4-C. Front with Integral Charge Pump, rear unit without Charge Pump.

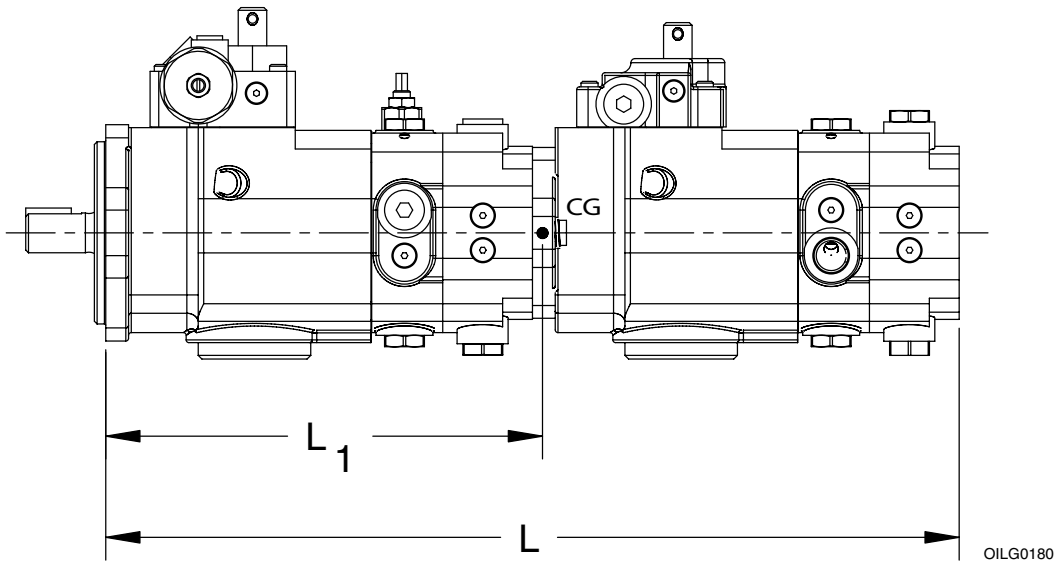

Charge Pump	Length* in. (mm)	Weight* lbs (kg)	L ₁ * in. (mm)
0.425 CIPR	18.8 (477,6)	76.0 (34,5)	9.4 (238,8)
0.64 CIPR	19.2 (487,6)	77.4 (35,2)	9.6 (243,8)

* Length and weights are for the 0.425 CIPR charge pump. Add 0.4 in. (10 mm) to length and 1.4 lbs (0,6 kg) to weight for 0.64 CIPR charge pump.

Table 4-D. Multiple units, both with Integral Charge Pumps.

TROUBLESHOOTING

PROBLEM	CAUSES	REMEDY	
Unresponsive or Sluggish Control	Swashblock (11) and/or Saddle Bearings (10) worn or damaged	Inspect and replace if necessary.	
	For Hydraulic CA Control Only, Control Piston orifice plugged or missing.	Inspect. Clean if plugged. Install orifice (393) if missing.	
Insufficient Pump Volume	High Pressure Relief Valve Cartridge (54) not seating	Inspect. Remove any contaminant that may not allow the cartridge (54) to seat or seal properly in Valve Plate (51) cavity.	
	Swashblock (11) not stroking to desired displacement.	Remove control assembly and eliminate any obstructions.	
	Charge pump and/or piston pump is cavitating		Decrease the drain leakage of external implements.
			Eliminate any possible leaks in the charge pump inlet plumbing that may be allowing air to enter.
			Make certain reservoir fluid level is adequate.
			Eliminate any obstructions or possible restrictions in the plumbing to the charge pump inlet. Elbows should have swept radii and have large openings. Overall length of the lines should be as short as possible.
			Inspect charge pump for excessive wear or damage, replace if necessary.
			Eliminate excessive air in reservoir fluid.
		Make certain that the fluid viscosity is in the manufacturer's recommended operating range.	
	Tow Valve is partially open	Turn Tow Valve (CW) until it seats	
	Insufficient input drive speed.	Check drive speed	
	Worn or grooved Cylinder Barrel (18) and/or Valve Plate (51) mating surfaces	Inspect and replace if necessary.	
	High Pressure Relief Valve Cartridge (54) damaged.		
	Failed Drive Shaft (1)		
Worn or damaged Piston Shoes (15) or Swashblock (11)			
Piston ball is loose in Piston Shoe socket (15)			
Worn Pistons and/or piston bores			
Swashblock (11) and/or Saddle Bearings (10) worn or damaged			
Irregular or Unsteady Operation	Charge pump and/or piston pump is cavitating	Decrease the drain leakage of external implements.	
		Eliminate any possible leaks in the charge pump inlet plumbing that may be allowing air to enter.	
		Make certain reservoir fluid level is adequate.	
		Eliminate any obstructions or possible restrictions in the plumbing to the charge pump inlet. Elbows should have swept radii and have large openings. Overall length of the lines should be as short as possible.	
		Inspect charge pump for excessive wear or damage, replace if necessary.	
		Eliminate excessive air in reservoir fluid.	
		Make certain that the fluid viscosity is in the manufacturer's recommended operating range.	
	Worn Control Pin (373) and/or Swashblock (11)	Inspect Control Pin outer diameter and Swashblock hole for wear, replace if necessary.	
Control input malfunction	Check mechanical, hydraulic, or electrical drivers for stability.		
Charge Pressure Relief Valve not regulating properly	Inspect poppet (71) and seat (in Gerotor Housing) for wear/erosion, replace if necessary.		
Faulty output circuit components (cylinder, motors, valves, or other related components)	Inspect and replace if necessary.		

TROUBLESHOOTING

PROBLEM	CAUSES	REMEDY
Loss of pressure	Worn Pistons (15) and/or piston bores	Inspect and replace if necessary.
	Worn or grooved Cylinder Barrel (18) and/or Valve Plate (51) mating surfaces	
	Worn or damaged Piston Shoes (15) or Swashblock (11)	
	Swashblock (11) and/or Saddle Bearings (10) worn or damaged	
	Piston ball is loose in Piston Shoe socket (15)	
	Worn Hydrodynamic Bearing (12)	
	Faulty output circuit components (cylinder, motors, valves, or other related components)	
	High Pressure Relief Valve Cartridge (54) not seating	Inspect. Remove any contaminant that may not allow the cartridge (54) to seat or seal properly in Valve Plate (51) cavity.
Excessive peak pressure	High Pressure Relief Valve Cartridge (54) not functioning properly.	Inspect and replace if necessary.
Excessive noise	Charge pump and/or piston pump is cavitating	Decrease the drain leakage of external implements.
		Eliminate any possible leaks in the charge pump inlet plumbing that may be allowing air to enter.
		Inspect charge pump for excessive wear or damage, replace if necessary.
		Eliminate excessive air in reservoir fluid.
		Make certain reservoir fluid level is adequate.
		Eliminate any obstructions or possible restrictions in the plumbing to the charge pump inlet. Elbows should have swept radii and have large openings. Overall length of the lines should be as short as possible.
	Make certain that the fluid viscosity is in the manufacturer's recommended operating range.	
	High Pressure Relief Valve Cartridge (54) leaking or regulating continuously	Inspect cartridge and machined seat in Valve Plate. Replace if necessary.
	Failed Front Drive Shaft Bearing (3)	Inspect and replace if necessary. Eliminate excessive side load on input drive shaft.
Failed charge pump (64)	Inspect and replace if necessary. Eliminate source of excessive contamination.	
Piston ball is loose in Piston Shoe socket (15)	Inspect and replace if necessary.	
Excessive wear on Fulcrum Ball (16) and socket of Shoe Retainer (14)		
Excessive heating	Operating piston and/or charge pump above rated continuous pressure for extended length of time.	Decrease system pressures to manufacturer's recommended levels.
	External heat source located too close to pump	Install a heat shield or deflector between the pump and heat source.
	High Pressure Relief Valve Cartridge (54) leaking or regulating continuously	Inspect. Remove any contaminant that may not allow the cartridge (54) to seat or seal properly in Valve Plate (51) cavity.
	Implement Pressure Relief Valve Cartridge (69) leaking or regulating continuously	Inspect cartridge and machined seat in Gerotor Housing (68). Replace if necessary.
	Inadequate cooling of "working loop" flow	Install a loop flushing valve to circulate some of the flow through the reservoir or a heat exchanger.
	Reservoir too small	Check manufacturer's recommended sizing for reservoir
	Tow Valve is partially open	Turn Tow Valve CW until it seats
	Damaged Hydrodynamic Bearing (12) and/or Barrel Cylinder (18)	Inspect and replace if necessary.
	Tow Valve stem (76) and/or seat (in Valve Plate) is worn or eroded	
	Worn or damaged Piston Shoes (15) or Swashblock (11)	
	Worn or grooved Cylinder Barrel (18) and/or Valve Plate (51) mating surfaces	

PRINCIPLE OF OPERATION

The illustrations show the pump driven counterclockwise (left hand) from the top (plane) view.

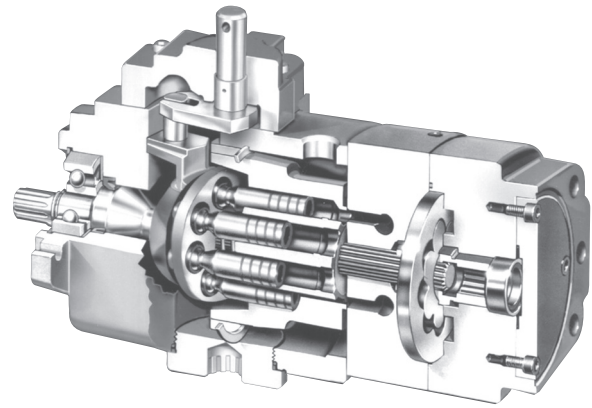

Figure 2. Cut-a-way of a Typical "PVWC" Pump

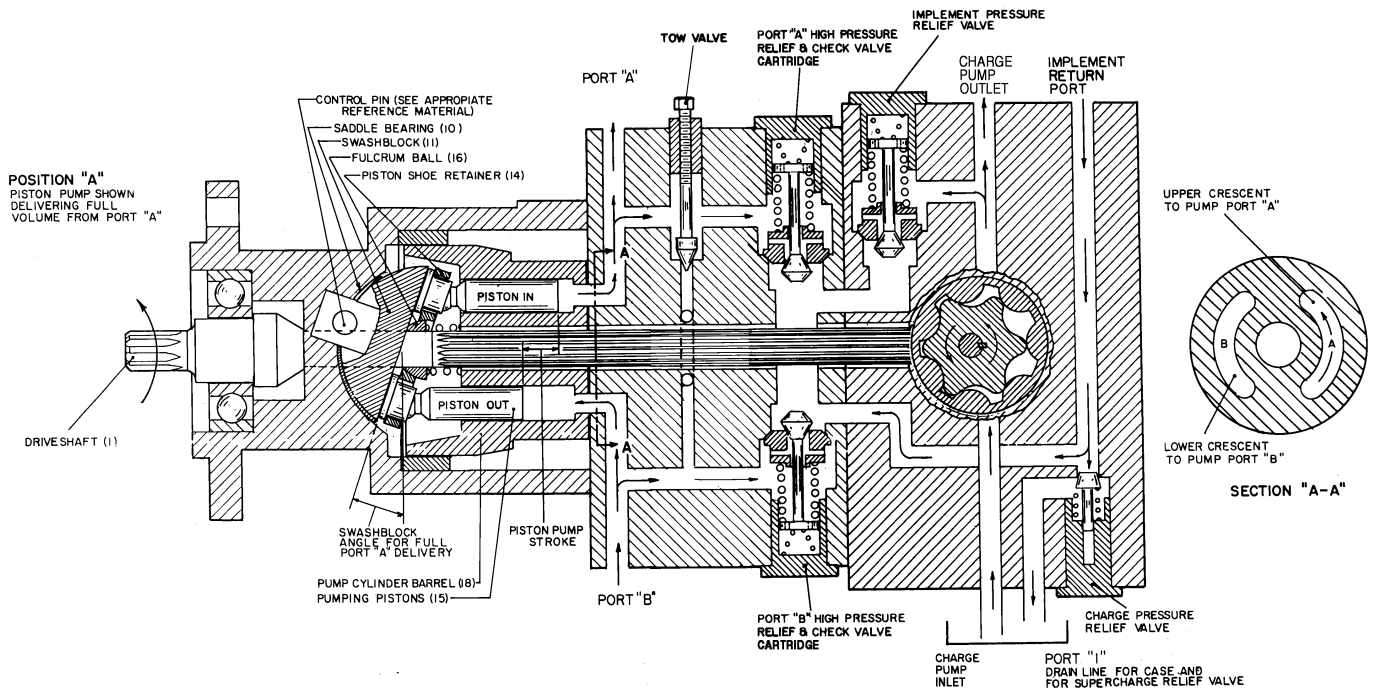

Figure 3. Position A, Swashblock Positioned for Full Delivery FROM PORT A

VARIABLE DELIVERY PUMP – FIGURE 3

The drive shaft (1) rotates the splined pump cylinder barrel (18) which contains pumping pistons (15) with swivel shoes. A shoe retainer (14), backed up by a spring loaded fulcrum ball (16), holds the piston shoes against a swashblock (11).

When the control positions the swashblock for full delivery from port A, the swashblock is at maximum angle (to the cylinder face). When cylinder is rotated, the pistons move in and out of their bores as shoes "ride" against the angled swashblock.

As the cylinder rotates, the individual piston bores are connected alternately to the lower (port B) and upper (port A) crescent shaped ports in the valve plate. While connected to port B crescent, each piston moves outward, drawing fluid into the piston bore until its outermost stroke is reached. At that point, the piston bore passes from the lower crescent (port B) to the upper crescent port.

While rotating across the upper crescent, each piston moves across the angled swashblock face and each piston is forced inward. Each piston displaces fluid through the upper crescent port to port **A** until its innermost stroke is reached. At that point, the piston bore passes from the upper to the lower crescent again and the operating cycle is repeated.

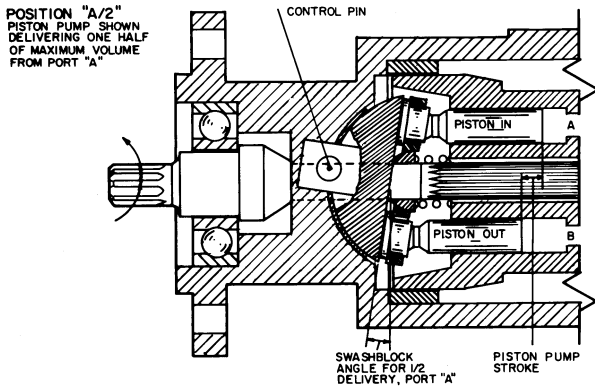

Figure 4. Position A/2, Swashblock Positioned for Partial Delivery From PORT A

The illustrations show that the degree of swashblock angle determines the length of piston stroke (the difference between outermost and innermost position) which also determines the amount of delivery from the pump.

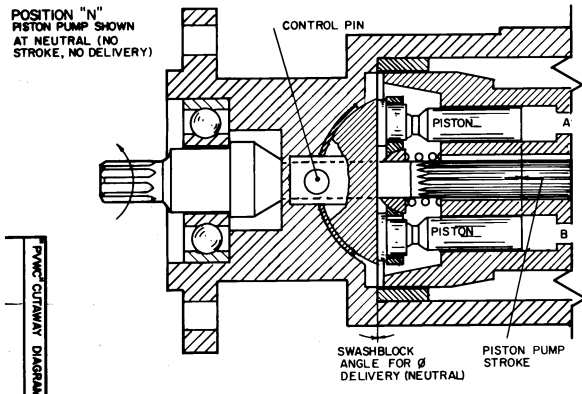

Figure 5. Position N, Swashblock Positioned for "NEUTRAL" (no stroke, no delivery)

Neutral position results when the control centers the swashblock. The swashblock angle is now zero and swashblock face is now parallel to cylinder face. No inward or outward motion of the pump pistons exist as piston shoes rotate around the swashblock face. The lack of inward and outward motion results in no fluid being displaced from the piston bores to the crescents in the valve plate, which means no delivery from pump ports.

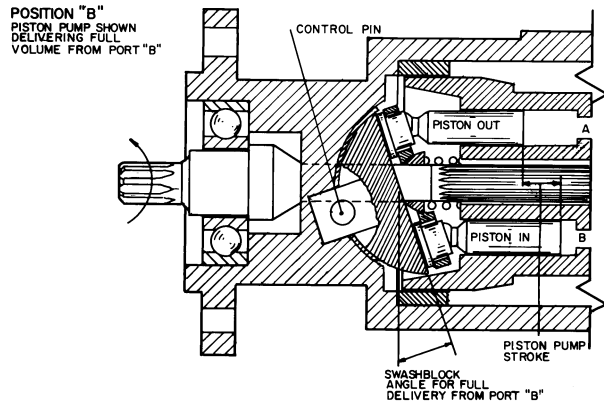

Figure 6. Position B, Positioned for Full Delivery From PORT B

For two-way pumps, the direction of swashblock angle determines which port is inlet or outlet. If the swashblock angle is reversed (from position A), the pistons will stroke **inward** during the lower half revolution, and deliver fluid to port **B**. During the upper half revolution, the pistons stroke **outward** and draw fluid from port **A**.

NOTE *When a two-way pump reverses flow ports, the rate of delivery is decelerated as the swashblock moves toward neutral position, flow is stopped as it crosses neutral position. Flow rate accelerates from the other port as swashblock moves in that direction. This means the flow reversal is "cushioned" by the pump itself. The degree of "cushion" is determined by the rate (speed) of swashblock reversal.*

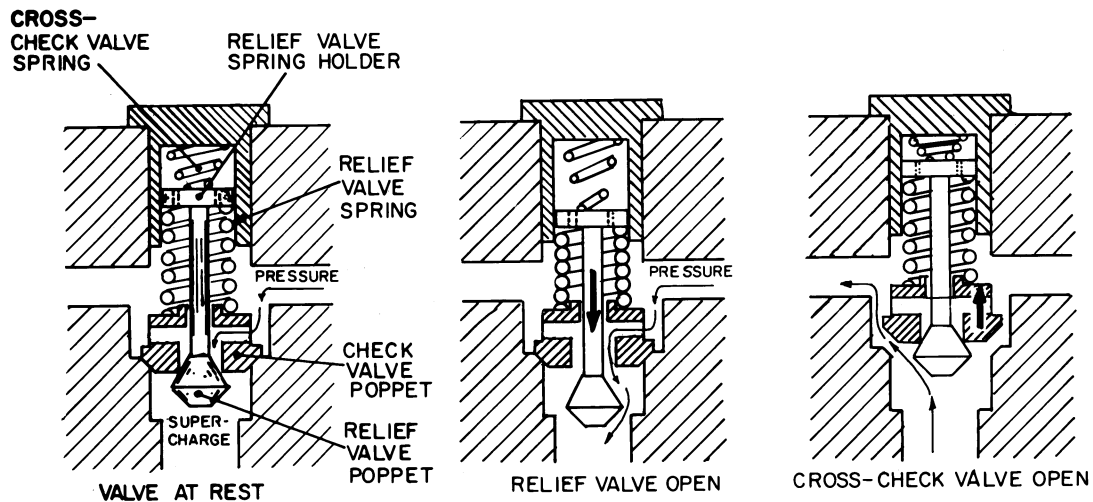

Figure 7. Diagram of Combination High Pressure Relief Valve and Cross-Check Valve

CHARGE (IMPLEMENT) PUMP (OPTIONAL GEROTOR TYPE) – REFER TO FIGURE 3

The inner element of the Gerotor rotor pump has one “tooth” less than the outer element which forms a series of “pockets.” As the inner element is rotated, the outer element also rotates. During the lower half revolution, the size of the “pockets” increase and fluid is drawn from the reservoir. As the rotation continues, the “pockets” of fluid are squeezed during the upper half revolution and fluid is delivered to supercharge the variable delivery pump, operate controls and implement circuits.

NOTE *Make sure operation of implement circuits does not prevent supercharge to the variable delivery pump.*

COMBINATION HIGH PRESSURE RELIEF VALVE (HPRV) AND CROSS-CHECK VALVE (CCV) – (OPTIONAL) FIGURE 7 -

A Combination High Pressure Relief Valve (HPRV) and Cross-Check Valve (CCV) are used for port **A** HPRV and are used for port **B** HPRV. A similar type of assembly is used for the Implement Pressure Relief Valve (IPRV). The main components in the cartridge consist of a relief valve poppet, a relief valve compression spring, a relief valve spring holder, a (seat washer) check valve poppet and a check valve spring.

In the “at rest” state, the HPRV poppet is pressed against (seat washer) check valve poppet and the cartridge is retained in position by the check valve

spring. To “open the relief valve,” relief valve poppet is actuated by the pressure on the top side (as shown) of the relief valve poppet. When the opening pressure is reached, the poppet pulls down the relief valve spring holder against the pre-loaded relief valve spring, the relief valve poppet opens and fluid flows into the supercharge circuit.

The “cross-check valves” open when the pressure on the supercharge circuit side is higher than the pressure on the top side (as shown), as would be the case when pump is delivering from the other pump. The entire cartridge compresses the cross-check valve spring and fluid flows from the supercharge circuit to the “return” side of the high pressure piston pump.

CHARGE PRESSURE RELIEF VALVE – REFER TO FIGURE 3

The high pressure piston pump is supercharged by exhaust from IPRV or return flow from the “implement” circuit. If the flow from any one or any combination of these is more than is necessary to supercharge the piston pump, the pressure acting on the face of the Charge Pressure Relief Valve poppet compresses the poppet spring allowing the poppet to move off of its seat and permit flow into the pump case and subsequently out the case drain.

TOW VALVE - (OPTIONAL) – REFER TO FIGURE 3

An optional "Tow Valve" package may be included for mobile applications allowing "free wheeling" of the (connected) hydraulic motor without disconnecting the drive (train) while the unit is being towed.

When the "Tow Valve" is in the closed position (as shown), the pump operates as previously described.

When the "Tow Valve" is in the open position (backed out two turns) it bypasses the pump ports and connected device ports (such as a hydraulic motor) to each other and (back) pressure is not raised in the piston pump system.

TESTING AND ADJUSTING

WARNING

Shut the pump OFF and release pressure from the system before disassembling components. Failure to comply with these instructions could result in personal injury or death. Blocking the pressure line between the pump and the system (or pump) high pressure relief valve will result in damage and could result in serious personal injury.

NOTE

The fluid must be warm during Testing and Adjusting.

HIGH PRESSURE RELIEF VALVES (HPRV) AND CROSS-OVER CHECK VALVES

To check pressure at pump high pressure ports **A** and **B**:

1. Connect a 6000 psi (415 bar) gage to lines (auxiliary ports) leading from these ports. **DO NOT block these lines with the gages.**
2. Start pump with control at "NEUTRAL" and adjust control for approximately 1/2 volume from port **A**.
3. Stall output shaft of driven motor or ram.

WARNING

Discharge fluid past relief valves only long enough to check pressure or excessive heating and damage can result.

Gage in port **A** line will read High Pressure Relief Valve (HPRV). Compare reading with SPECIFICATIONS listed in Table 5.

4. Shift control for 1/2 delivery from port **B** and repeat the procedure.

The HPRVs are non-adjustable. If the relief valves test faulty; remove them, flush them to remove contamination or debris and re-test. If they still test faulty, replace them. The relief valves have to be replaced as an assembly.

IMPLEMENT PRESSURE RELIEF VALVE (IPRV)

To check pressure:

1. Connect 2000 psi (150 bar) gage to line from the Charge Pump Outlet. **DO NOT block line with gage.**
2. Route line through a needle valve and back to the Implement Return Port. Record the pressure when the valve is closed.
3. Compare gage reading with Specifications listed in Table 5.

The IPRV is non-adjustable. If the relief valve tests faulty, remove it, flush it to remove contamination or debris and re-test. If it still tests faulty, replace it. The relief valve has to be replaced as an assembly.

CAUTION

Dirty filter elements in the implement circuit may cause pressure drop, restricting available pilot pressure.

High Pressure Relief Valve

Model Code Designation	Nominal Setting	Cracking Pressure	
		Minimum	Maximum
10	1450 psi (100 bar)	1378 psi (95 bar)	1523 psi (105 bar)
14	2030 psi (140 bar)	1929 psi (133 bar)	2132 psi (147 bar)
17	2500 psi (175 bar)	2410 psi (166 bar)	2664 psi (184 bar)
19	2730 psi (188 bar)	2610 psi (180 bar)	2842 psi (196 bar)
21	3045 psi (210 bar)	2893 psi (200 bar)	3197 psi (220 bar)
25	3625 psi (250 bar)	3444 psi (238 bar)	3806 psi (262 bar)
28	4060 psi (280 bar)	3857 psi (266 bar)	4263 psi (294 bar)
35	5075 psi (350 bar)	4821 psi (332 bar)	5329 psi (368 bar)

Implement Pressure Relief Valve

Model Code Designation	Nominal Setting	Cracking Pressure	
		Minimum	Maximum
J	725 psi (50 bar)	689 psi (48 bar)	761 psi (52 bar)
D, E, or F	913 psi (63 bar)	867 psi (60 bar)	959 psi (66 bar)
K	1160 psi (80 bar)	1102 psi (76 bar)	1218 psi (84 bar)
L	1450 psi (100 bar)	1378 psi (95 bar)	1523 psi (105 bar)

Table 5. PVWC High Pressure and Implement Relief Valve Specifications

CHARGE PUMP

NOTE Ratio test results for drive speeds other than 1800 rpm accordingly.

If pilot pressure is still insufficient after completing previous measure:

Check the rest of the implement circuit to be sure fluid is not bypassed or leaking in the circuit. If not;

1. Install a 0 to 10 gpm flow meter directly after the needle valve of the test circuit described above.

2. Start pump with control at neutral (zero delivery), and needle valve "wide" open.
3. Close needle valve to increase charge pump pressure. Compare flow readings to the applicable charge pump performance plot. Refer to **Figures 8 and 9**.

NOTE *Reduced delivery indicates wear, but does not become critical until pressure and/or delivery necessary to supercharge pump, or to operate implements can't be obtained.*

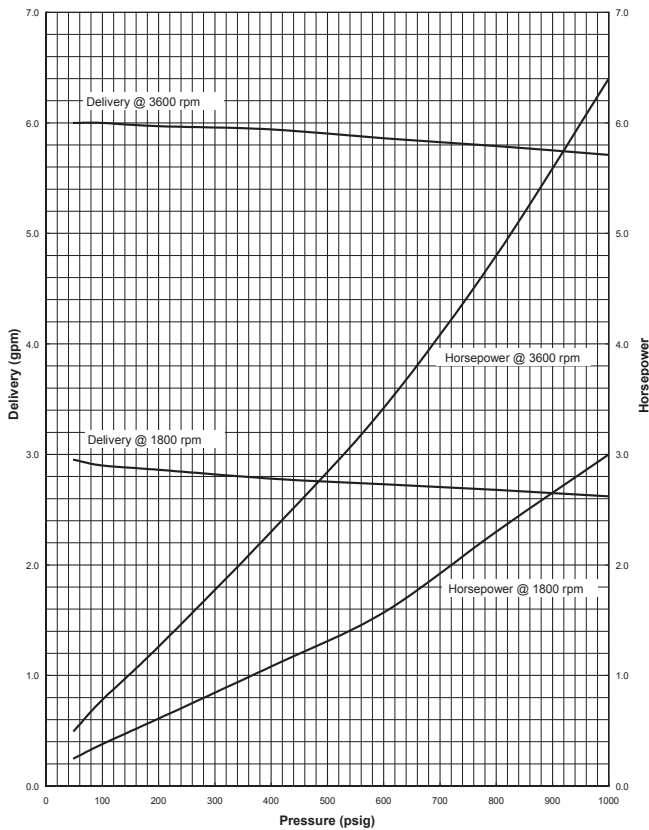

Figure 8. 0.425 cipr Charge Pump Performance

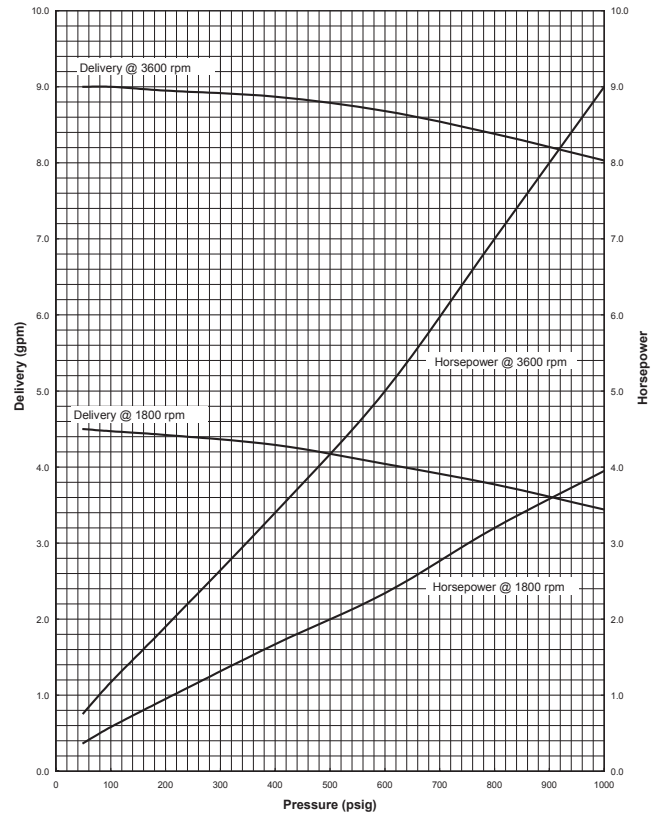

Figure 9. 0.64 cipr Charge Pump Performance

CHARGE PRESSURE RELIEF VALVE

NOTE *Charge pump delivery must be warm and control set at "NEUTRAL" (zero delivery).*

To check charge pressure relief valve setting:

Install a 1000 psi (70 bar) pressure gage after the needle valve and immediately before the implement return port of the circuit described for checking the implement pressure relief valve.

Compare gage pressure reading with specified pressure in Figure 10. Refer to **Figure 10**.

The charge pressure relief valve is non-adjustable. If the relief valve tests faulty, remove it, flush it to remove contamination or debris, inspect the poppet and seat for erosion, and inspect the spring for wear. If it still tests faulty, replace all worn parts.

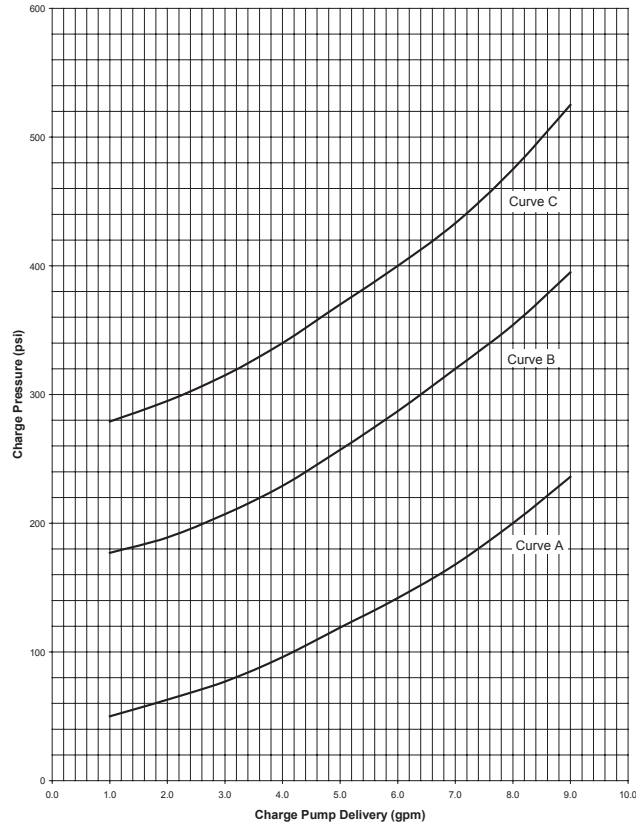

Figure 10. Charge Pressure Relief Valve

PISTON PUMP

NOTE *Ratio test results for drive speeds other than 1800 rpm accordingly.*

To check for worn piston pump:

Warm up unit, make sure pump is under pressure and measure the pump flow from both port **A** and port **B**.

Install a flow meter at port **A** and connect 6000 psi (415 bar) gage to line (auxiliary port) leading from port **A**. **Do not block this line with the gage.**

1. Start pump, put it on stroke for port **A**.
2. Raise system pressure to rated continuous pressure per **Table 2**.
3. Read the flow meter and compare to rating in **Table 2**.
4. Install flow meter and pressure gage at port **B**. Repeat procedure, putting pump on stroke for delivery from port **B**.

NOTE *Reduced flow indicates wear, but does not become critical until it impairs performance.*

CONTROL

Refer to applicable, referenced Oilgear Volume Control Information Bulletins.

NOTE *When referring to control sizes PVWH 04 = PVWC 011, PVWH 06 = PVWC 014 and PVWH 10 = PVWC 022.*

DISASSEMBLY

Refer to **Figures 13-A, 13-B or 13-C**.

NOTE *The cleanliness of working on this pump or the hydraulic system is extremely important to the safety and reliability of the pump and the system.*

When disassembling or assembling the pump, choose a clean, dry, dust and sand free area where no traces of abrasive particles are in the air which can damage the pump and system. DO NOT work near welding, sandblasting, grinding benches or similar conditions.

Always make sure the fittings are clean on the outside before removing them from their connections. Make sure they are capped and plugged when removed. Place them on a clean surface and in a clean rag or container until they are reinstalled. When cleaning parts which have been disassembled, it is important to use CLEAN cleaning solvents and parts are allowed to dry. All tools and gauges should be clean prior to working with the system and use new, CLEAN lint free rags to handle and dry parts.

NOTE *If an O-ring or seal is removed, they can not be reused. They must be replaced.*

WARNING

DO NOT attempt to remove or install any components or assembly while the pump and system is running. Always stop the pump, shut OFF the power and release pressure from the system before servicing or testing. Be sure provisions have been made so the case drain line can be disconnected from the unit without causing the line to drain (siphon) the reservoir.

1. Disconnect case drain line(s).
2. Drain pump case. If drain pump case plugs are inaccessible, it may be necessary to remove the pump from the mounting and drive motor before draining it.

WARNING

Seek assistance capable of handling 200 lbs (90,7 kg) from others and use of a hoist and/or proper lifting techniques to prevent personal injury.

NOTE Tag similar parts (particularly screws, plugs and O-rings) during disassembly to make sure they don't become confused with similar parts and to ensure they will be returned to their original location. Do not remove (locator) roll pins unless they are deformed or need to be replaced.

3. After removing the pump from the mounting and before disassembly, cap or plug all ports and clean the outside of unit thoroughly to prevent contaminant from entering the system.

NOTE Depending on what part or parts are to be inspected, it may not be necessary to completely take apart all assemblies. Disassembly of the pump not required if only the drive shaft seals need to be replaced. Refer to Drive Shaft Group.

CONTROL GROUP

Refer to applicable, referenced Oilgear Volume Control Information Bulletins on the control your unit is equipped with.

1. Remove four cap screws (303) and lift the control group assembly, with control pin (373), straight up from the top of the pump assembly. The control pin may or may not remain in the swashblock (11).
2. Remove control gasket (369) and O-rings (356) from pump housing.

VALVE PLATE GROUP

If another unit is coupled with a thru shaft pump or other device coupled to the rear of unit, it may be necessary to remove that unit before removing the rear assembly.

1. Block unit on bench with drive shaft facing down.
2. Remove socket head screws (50).
3. Lift rear assemblies straight up and place on a bench with the valve plate (51 or 51A) facing up.
4. Remove valve plate gasket (21) and O-rings (28).

5. If applicable, separate valve plate (51) from the Gerotor housing (68A).

CAUTION

Be sure to identify HPRV assemblies when removed so they can be returned to proper port A or port B position when they are re-assembled.

6. Remove both pressure relief valve caps (52) with O-rings (53).
7. Withdraw HPRV cartridges w/cross-line check valve springs (54).
8. Loosen lock nut (81) and turn tow valve stem (76) partially out.
9. Remove tow valve bonnet (79) with valve stem (76) backup ring (78) and O-ring seal (77) in place.

GEROTOR HOUSING GROUP

1. Remove O-rings (60 and 61).
2. Remove the Gerotor pump/coupling assembly (62).
3. Remove Implement Pressure Relief Valve (IPRV) cap (52) with O-ring (53).
4. Withdraw implement pressure relief valve assembly (69) from rear plate (68).
5. Remove Charge Pressure Relief Valve cap (70) with O-ring (53) and lift out poppet (71) with spring (72).

ROTATING GROUP

1. Place the pump in a horizontal position.
2. Remove the rotating group by turning the drive shaft (1) slowly, while pulling the cylinder barrel (18) from the housing.
3. Identify (number) each pump piston shoe assembly (15) and its respective bore in the cylinder barrel (18) and shoe retainer (14) for easy re-assembly.
4. See Figure 8. Lift out shoe retainer (14) with pistons (15) and remove the fulcrum ball (16) and shoe retainer spring (17).

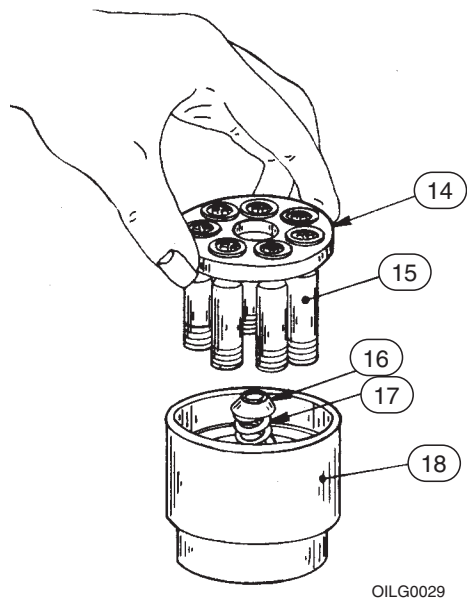

Figure 11. Rotating Group Disassembly

5. Remove retaining ring (13) and pull the hydrodynamic bearing (12) from the housing. Identify the position of hydrodynamic cylinder bearing roll (locating) pin (12A) in relation to the housing (5) for ease when re-assembled.

DRIVE SHAFT GROUP

1. Remove drive shaft bearing retainer ring (29).
2. Grasp outboard end of drive shaft (1) and pull out from pump housing.
3. Remove seal retainer (6). Remove shaft seal (7) from housing only if necessary.

NOTE Shaft seal must be replaced if removed from housing.

SWASHBLOCK GROUP

1. Reach inside the case and remove the swashblock (11).
2. Identify which saddle bearing is the top (10A) and which is the bottom (10B) and remove if necessary from housing.

INSPECTION

Clean all parts thoroughly and allow them to dry. Inspect all seals and O-rings for hardening, cracking or deterioration. Replace if necessary or if you suspect damage. Check all locating pins for damage and springs for cracking or signs of cracking or signs of wear.

⚠ WARNING

Wear proper protective gear when using solvents or compressed air, servicing or maintaining the hydraulic system or the Oilgear pump. Wear correct protective gear, safety glasses, gloves, and safety shoes. Serious injury can result without proper protective gear.

CONTROL GROUP

Refer to the reference material on pump controls. Be sure to carefully check the control pin for cracks and/or signs of fatigue. Check fit of the pin in the swashblock. It should be a slip-fit without side-play. Replace if necessary or if you suspect damage.

VALVE PLATE GROUP

Inspect the valveplate (51) surface which mates with the cylinder barrel (18) for excessive wear or scoring. Remove minor defects by lightly stoning the surface with a hard stone which is flat to within 0.001 inches (0,03 mm).

NOTE Be sure to stone lightly. Any excessive stoning will remove the hardened surface. If wear or damage is extensive, replace the valve plate and cylinder barrel.

Wash and dry High Pressure Relief Valve assemblies. Inspect poppets and seats for scratches or signs of erosion. If assemblies show signs of wear and/or malfunction; they must be replaced as an assembly. If check valve seats are grooved or eroded, it maybe necessary to replace valve plate (51) and/or rear plate (68).

ROTATING GROUP

Inspect cylinder barrel **(18)** piston bores and the face which mate with the valve plate for wear or scoring. Remove minor defects by lightly stoning the surface with a hard stone which is flat to within 0.001 inches (0,03 mm).

NOTE *Be sure to stone lightly. Any excessive stoning will remove the hardened surface. If wear or damage is extensive and defects cannot be removed, replace the cylinder barrel.*

See **Figure 12**. Check each shoe face for nicks and scratches, and the shoe for smooth pivot action on the piston.

NOTE *If one or more piston/shoe assembly needs to be replaced, replace all the piston/shoe assemblies. When installing new piston/shoe assemblies or the rotating group, make sure the pistons move freely in their respective bores.*

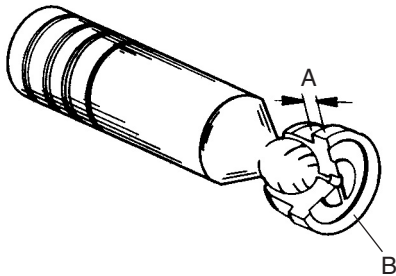

OILG-0005

Figure 12. Piston and Shoe Inspection

(A) All shoes must be equal within 0.001 inches (0,025 mm) at this dimension.

(B) All shoe faces must be free of nicks.

NOTE *End play should not to exceed 0.003 inches (0,076 mm) when new or 0.006 inches (0,152 mm) when worn.*

SWASHBLOCK GROUP

Inspect the swashblock **(11)** for wear and scoring. If defects are minor, stone the swashblock lightly. If damage is extensive, replace the swashblock.

Check the small holes in the face of the swashblock. The hole provides “porting” for the hydrostatic balance fluid of the piston/shoe assembly to be channeled through the swashblock to the face of the saddle bearing, providing pressure lubrication.

Compare the saddle bearing **(10A and 10B)** thickness in a worn area to thickness in an unworn area. Replace saddle bearings if the difference is greater than 0.015 inches (0,4 mm).

Check the mating surface of swashblock for cracks or excessive wear. The swashblock movement in the saddle bearings must be smooth. Replace if necessary.

NOTE *Be sure to stone lightly. Any excessive stoning will remove the hardened surface. If wear or damage is extensive and defects cannot be removed, replace if necessary or if you suspect them of being bad.*

DRIVE SHAFT GROUP

Check:

- the shaft seal **(7)** for deterioration or cracks. Replace if necessary (press-out).
- the front shaft bearing **(3)** for galling, pitting, binding or roughness.
- the rear shaft bushings **(55)** in valve plate.
- the shaft and its splines for wear. Replace any parts necessary.

GEROTOR PUMP GROUP

Check:

- the faces and outside diameter of the Gerotor pump assembly **(64)**.
- the matching faces of the valve plate **(51)** and Gerotor housing **(68)** for scratches or grooves.

Remove minor defects by lightly stoning or lapping the surface. Only stone or lap Gerotor pump mating surfaces. If wear or damage is extensive, it may be necessary to replace the Gerotor pump assembly **(64)**, and the valve plate **(51)** and Gerotor housing **(68)**.

NOTE *Be sure to stone lightly. Any excessive stoning will remove the hardened surface. If wear or damage is extensive and defects cannot be removed, replace if necessary or if you suspect them of being bad.*

GEROTOR HOUSING GROUP

Wash and dry Implement Pressure Relief Valve (IPRV) assembly. Inspect the poppet and seat for scratches or signs of erosion. If assembly shows sign of wear and/or malfunction, it must be replaced as an assembly.

Check Charge Pressure Relief Valve poppet (71) and its seat for signs of wear. Replace poppet and/or Gerotor housing (68). The poppet seat can not be refinished. It must be replaced.

ASSEMBLY

NOTE *During re-assembly, torque fasteners and plugs to specifications in Table 9. Refer to Table 9.*

See **Figures 13-A, 13-B or 13-C**. Follow the disassembly procedures in reverse for re-assembling the pump.

During assembly, install new gaskets, seals and O-rings. Apply a thin film of CLEAN grease or hydraulic fluid to sealing components to ease assembly. If a new rotating group is used, lubricate thoroughly with CLEAN hydraulic fluid. Apply fluid generously to all wear surfaces.

SWASHBLOCK GROUP

If removed,

1. Press shaft seal (7) into front of pump housing (5) until it is flush with the bore.
2. Place housing on a bench with the mounting flange side down.
3. Make sure the saddle bearings (10A and 10B) are replaced back into their original position.
4. Place the swashblock (11) into the case and be sure the swashblock swivels in the saddle bearings. With new bearings, swiveling may be stiff (not always smooth).
5. Position the cylinder hydrodynamic bearing (12) into the case so the pin (in the bearing) will fit at 3:00 or 9:00 o'clock position, in the wide slot found across the inside of the pump housing (5). The bearing should fit into place with little difficulty and be square to the axis of the pump.
6. Tap bearing into place if necessary. Use extreme care not to damage the bearing.

7. Insert retaining ring (13) to hold bearing in place.

DRIVESHAFT GROUP

1. Place housing on its side with axis horizontal and then install seal retainer (6).
2. Lubricate shaft seal (7) and shaft.
3. Carefully insert driveshaft and bearing assembly into pump housing (5) and lock in place with driveshaft bearing retainer ring (29).

ROTATING GROUP

See **Figure 11**.

1. Place the cylinder barrel (18), wear surface down, on a clean cloth.
2. Place the shoe retainer spring (17) in the center of the barrel with the fulcrum ball's (16) flat face on top of it.

NOTE *Before dropping the pistons/shoe assemblies (15) into holes of the shoe retainer (14), hold the retainer horizontally so the curved surface of the inside shaft bore is on the bottom side. This is necessary so the curved surface of the retainer will mate with the curved surface of the fulcrum ball.*

3. As a unit, insert the identified pistons into their corresponding identified bores in the cylinder barrel. **DO NOT FORCE**. If aligned properly, the pistons will fit smoothly.

The rotating group can now be carefully installed over the tail of the drive shaft (1) and into the pump housing (5).

NOTE *When installing the rotating group, support the weight of the cylinder barrel (18), as cylinder spline is passed over the tailshaft, to avoid scratching or damage.*

4. Push cylinder forward until the cylinder spline encounters the hydrodynamic cylinder bearing (12). Lifting the tail shaft slightly helps the cylinder barrel (18) and cylinder bearing (12) engagement. Continue pushing the cylinder forward until the piston shoes contact the swashblock. At this point, the back of the cylinder should be located slightly outside the back of the pump housing.

GEROTOR HOUSING

If removed:

1. Slip spring (72) on poppet (71) and place in cap (70) bore.

With O-ring (53) in place on charge pressure relief valve cap (70):

2. Screw cap (70) with O-ring (53) tightly into place. Install the IPRV (69) into place with the check valve spring's largest diameter coil towards cap (52). With O-ring (53) in place, secure with cap (52). Torque as specified in Table 9.
3. Insert screws (50) thru bores in the Gerotor housing (68) and place assembly on work bench with the threaded end of screws pointing up.
4. Mount rear cover (90) on plate and secure with screws (92). Torque as specified in Table 9.

GEROTOR PUMP GROUP

1. Insert the Gerotor pump/coupling assembly into the rear plate.
2. Put O-rings (60 and 61) in place and insert outer Gerotor assembly into the counter bore of the rear plate (68).

VALVE PLATE GROUP

CAUTION

Use extreme care not to damage the faces of the valve plate and matching faces of both the valve plate and cylinder barrel.

NOTE

Make sure O-rings are in place.

If removed:

1. Place O-ring seal (77) and backup ring (78) on tow valve stem (76).
2. Screw stem into bottom side of tow valve bonnet (79) as far as possible. With O-ring (80) in place, screw bonnet assembly into valve into valve plate (51). Torque as specified in Table 9.
3. Turn tow valve stem in until it closes (seats).
4. Install lock nut (81) and tighten.
5. Place the port A HPRV assembly (54) and cross-line check valve spring into its bore with the large diameter coil towards the cap (52). With O-ring (53) in place, secure assembly with cap (52). Torque as specified in Table 9.
6. Repeat procedure for port B HPRV assembly (54).
7. Position valve plate assembly so the locating pins (58) will be received by the Gerotor assembly (68).
8. Lower the valve plate assembly (51) over screws (50) onto the Gerotor housing assembly.
9. Place the pump housing on bench with open end facing up.
10. Install new O-rings (28) and gasket (21) on housing. Use your hands or another person's help to hold (clamp) the rear plate/Gerotor pump/valve plate assembly together, lift assembly and turn upside down so socket head cap end of screws (50) is on top.
11. Slowly lower the assembly onto the pump housing assembly. Make sure the rear spline of the shaft engages Gerotor pump coupling while positioning the valve plate (51) on pins (19) and housing.
12. Finger tighten socket head cap screws (50) and then alternately tighten and torque cap screws per Table 9. Refer to **Table 9**.

CONTROL GROUP

Refer to applicable, referenced Oilgear Volume Control Information Bulletins on the control your unit is equipped with. Refer to **Table 9** for torques to secure control group to the pump housing.

Pump Model	Fastener or Plug	Head Type/Size	Tightening Torque
PVWC with Charge Pump	Valve Plate Screws (item 50)	5/16" Internal Hex	45 ft•lbs (61 N•m)
	High Pressure Relief Valve Cap (item 52)	7/8" External Hex	50 ft•lbs (68 N•m)
	Implement Pressure Relief Valve Cap (item 52)	7/8" External Hex	50 ft•lbs (68 N•m)
	Charge Pressure Relief Valve Cap (item 70)	7/8" External Hex	50 ft•lbs (68 N•m)
	Tow Valve Bonnet (item 79)	7/8" External Hex	50 ft•lbs (68 N•m)
	SAE #3 Plug (item 56)	1/8" Internal Hex	45 in•lbs (5 N•m)
	Housing Plug (item 83)	3/4" Internal Hex	100 ft•lbs (136 N•m)
	Cover Plate Screws (item 92)	5/32" Internal Hex	45 in•lbs (5 N•m)
	SAE #8 Plug (item 95)	5/16" Internal Hex	50 ft•lbs (68 N•m)
	Tandem Pump Mounting Screws (item 97)	9/16" External Hex	45 ft•lbs (61 N•m)
PVWC without Charge Pump	Valve Plate Screws (item 50)	5/16" Internal Hex	45 ft•lbs (61 N•m)
	High Pressure Relief Valve Cap (item 52)	7/8" External Hex	50 ft•lbs (68 N•m)
	Charge Pressure Relief Valve Cap (item 70)	11/16" External Hex	320 in•lbs (36 N•m)
	Tow Valve Bonnet (item 79)	11/16" External Hex	320 in•lbs (36 N•m)
	Housing Plug (item 83)	3/4" Internal Hex	100 ft•lbs (136 N•m)
	Cover Plate Screws (item 92)	5/32" Internal Hex	45 in•lbs (5 N•m)
	Tandem Pump Mounting Screws (item 97)	9/16" External Hex	45 ft•lbs (61 N•m)
MN & MS Controls	Control Body Mounting Screws (item 303)	3/16" Internal Hex	140 in•lbs (16 N•m)
	SAE #2 Plug (item 361)	1/8" Internal Hex	45 in•lbs (5 N•m)
	SAE #8 Plug (item 360)	5/16" Internal Hex	50 ft•lbs (68 N•m)
CA Control	Control Body Mounting Screws (item 303)	3/16" Internal Hex	140 in•lbs (16 N•m)
	SAE #2 Plug (item 361)	1/8" Internal Hex	45 in•lbs (5 N•m)
	SAE #4 Plug (item 333)	3/16" Internal Hex	120 in•lbs (13.5 N•m)
	End Plug (item 391)	1 1/2" External Hex	160 ft•lbs (217 N•m)
	SAE #16 Plug (item 392)	5/8" Internal Hex	135 ft•lbs (183 N•m)
	Neutral Switch (item 335)	7/8" External Hex	320 in•lbs (36 N•m)
	Adjuster Cap (item 394)	1" External Hex	45 in•lbs (5 N•m)
VM & VS Controls	Control Body Mounting Screws (item 303)	7/16" External Hex	140 in•lbs (16 N•m)
	SAE #2 Plug (item 361)	1/8" Internal Hex	45 in•lbs (5 N•m)
	Servo Valve & Adaptor Plate Screws	3/16" Internal Hex	57 in•lbs (6.5 N•m)
	End Cap Screws (item 374)	3/16" Internal Hex	140 in•lbs (16 N•m)
	SAE #8 Plug (item 360)	5/16" Internal Hex	50 ft•lbs (68 N•m)

Table 9. PVWC Screw and Plug Torques

PARTS LIST

Parts used in these assemblies are per Oilgear specifications. Use only Oilgear parts to ensure compatibility with assembly requirements. When

ordering replacement parts, be sure to include pump type and serial number, bulletin number and item number. Specify type of hydraulic fluid to assure seal and packing compatibility.

NOTE

Parts drawings may not be identical to OilGear drawings referenced.

PVWC Pump Assembly Without Charge Pump (see Figures 13-A and 13-B)

Item	Qty.	Description	Item	Qty.	Description
Housing Assembly Group			Housing Assembly Group		
1A	1	Driveshaft, Y 7/8" Keyed	51B	1	Valve Plate, PVWC-011 LH NT
2		Key, 0.25 Sq X 1.0 Lg			Valve Plate, PVWC-011 LM NT
1B		Driveshaft, S 9T, 5/8" Spline			Valve Plate, PVWC-011 RH NT
1C		Driveshaft, L 13T, 7/8" Spl Ind			Valve Plate, PVWC-011 RM NT
1D		Driveshaft, K 13T, 7/8"X.50 Spl			Valve Plate, PVWC-014 LH NT
3	1	Bearing, Front Driveshaft			Valve Plate, PVWC-014 LM NT Valve Plate, PVWC-014 RH NT
4	1	Ring, Shaft Retainer			Valve Plate, PVWC-014 RM NT
5	1	Pump Housing, SAE "A" Mount, Standard			Valve Plate, PVWC-022 LH NT
		Pump Housing, SAE "B" Mount, Standard			Valve Plate, PVWC-022 LM NT
		Pump Housing, SAE "A" W/2 Case DR Ports			Valve Plate, PVWC-022 RH NT
		Pump Housing, SAE "B" W/2 Case DR Ports	Valve Plate, PVWC-022 RM NT		
6	1	Retainer, Seal	52	+	Cap, Relief Valve
7	1	Seal, Shaft	53	+	O-Ring
10	2	Bearing, Saddle	54	+	HPRV Cartridge, 1450 psi/100 bar
11	1	Swashblock			HPRV Cartridge, 1812 psi/125 bar
12	1	Bearing, Hydrodynamic			HPRV Cartridge, 2030 psi/140 bar
12A	1	Pin, Roll			HPRV Cartridge, 2537 psi/175 bar
					HPRV Cartridge, 3045 psi/210 bar
13	1	Ring, Retainer			HPRV Cartridge, 3625 psi/250 bar
14	1	Retainer, Shoe			HPRV Cartridge, 4060 psi/280 bar
15	7	Piston and Shoe Assembly, -011			HPRV Cartridge, 5075 psi/350 bar
		Piston and Shoe Assembly, -014	62	1	Coupling
		Piston and Shoe Assembly, -022	63	1	Ring, Retaining
16	1	Ball, Fulcrum	70	1	Cap
17	1	Spring, Shoe Retainer	71	1	Poppet
18	1	Barrel, Cylinder, -011	72	1	Spring, Charge (Code A,B,E)
		Barrel, Cylinder, -014			Spring, Charge (Code C,D,M)
		Barrel, Cylinder, -022			Spring, Charge (Code F,G,H,J,K,L)
19	2	Pin, Roll	76	1	Stem, Tow Valve
21	1	Gasket, Valve Plate	77	1	O-Ring
26	1	Nametag	78	1	Ring, Backup
27	2	Screw, Drive	79	1	Bonnet, Tow Valve
28	2	O-Ring	80	+	O-Ring
29	1	Ring, Bearing Retainer	81	1	Nut, Jam
50	4	Screw, SHC 0.375-16UNC X 2.5 Lg	83	1	Plug, Access
51A	1	Valve Plate, PVWC-011 LH	84	1	O-Ring
		Valve Plate, PVWC-011 LM	90	1	Cover Plate
		Valve Plate, PVWC-011 RH	91	1	O-Ring
		Valve Plate, PVWC-011 RM	92	5	Screw, SHC #10-24UNC X 0.38 Lg
		Valve Plate, PVWC-014 LH	93	+	Spring, 00 HPRV Option
		Valve Plate, PVWC-014 LM Valve Plate, PVWC-014 RH	94	+	Ball
		Valve Plate, PVWC-014 RM	96	1	O-Ring
		Valve Plate, PVWC-022 LH	97	2	Screw, HHC 0.375-16UNC X 1.00 Lg
		Valve Plate, PVWC-022 LM	98	2	Washer, Lock
		Valve Plate, PVWC-022 RH	99	1	Washer
		Valve Plate, PVWC-022 RM			

+ Quantities vary on units.

PVWC Pump Assembly Without Charge Pump (con't.)

Item	Qty.	Description
Pump Control Assembly Group		
303	4	Screw, SHC 0.250-20UNC X 1.0 Lg (MN/MS)
		Screw, SHC 0.250-20UNC X 1.5 Lg (CA)
		Screw, HHC 0.250-20UNC X 2.5 Lg (VM/VS)
332	2	O-Ring
333	2	Plug, #4 HP
334	1	O-Ring
335	1	Neutral Switch, N.O.
		Neutral Switch, N.C.
340A	1	VM Servo Valve Assembly
340B		VS Servo Valve Assembly
341	1	O-Ring
342	4	O-Ring (VM)
		O-Ring (VS)
345	1	L.V.D.T.
347	1	Ring, Retaining
351	1	Stem, L.V.D.T.
352	2	O-Ring
356	2	O-Ring
360	*	Plug, #8 HP
361	**	Plug, #2 HP
362	1	Arm and Pintle Assembly, MN/MS
		Arm and Pintle Assembly, CA
363	1	Piston, CA Control
364	1	Piston, VM/VS Control
368	1	Control Housing, MN
		Control Housing, MN w/o Vol Stop
		Control Housing, MS
		Control Housing, MS w/o Vol Stop
		Control Housing, CA
		Control Housing, CA w/ Switch
369	1	Gasket, Control
370	1	Spring, CA Centering
372	2	Cover, VM/VS Control
373	1	Control Pin, MN/MS
		Control Pin, CA
		Control Pin, VM/VS
374	8	Screw, SHC 0.250-20UNC X 1.00 Lg
375	*	O-Ring
376	2	O-Ring
378	1	Stem, Adjustment
382	2	Guide, Spring
385	**	O-Ring
390	3	Nut, Jam
391	1	Plug, End
392	1	Plug, #16 HP
393	1	Orifice, #10-24UNC w/ 0.032 dia.
394	1	Adjuster Cap
395	1	O-Ring

PVWC O-Rings (Common to Units With and Without Charge Pump)

PVWC O-Ring Sizes		
Item Number	ARP 568 Size Number	Applies to models:
28	010-90	All Pumps
53	908-90	All Pumps
57	903-90	PVWC w/ Charge Pump Only
60	152-70	PVWC w/ Charge Pump Only
61	012-90	PVWC w/ Charge Pump Only
77	010-90	PVWC w/o Charge Pump
	012-90	PVWC w/ Charge Pump
80	906-90	PVWC w/o Charge Pump Only
84	138-70	All Pumps
91	028-90	All Pumps
96	042-70	All Pumps
332	904-90	CA Control
334	906-90	CA Control
341	016-70	CA, MN, & MS Controls
342	012-90	VM Control
	904-90	VS Control
352	117-90	VM & VS Controls
356	013-90	All Controls
375	908-90	MN, MS, VM, & VS Controls
376	916-90	CA Control
385	902-90	All Controls
395	115-70	CA Control

* 2 for MN/MS, 1 for VM/VS

** 2 for CA, MN/MS, 6 for VM/VS

PARTS LIST drawings, Figures 13-A and 13-B.

PVWC Pump Assembly With Charge Pump (See Figures 13-B and 13-C)

Item	Qty.	Description	Item	Qty.	Description
Pump Assembly PVWC			Pump Assembly PVWC		
1A	1	Driveshaft, Y 7/8" Keyed	54	2	HPRV Cartridge, 1450 psi/100 bar
2		Key, 0.25 Sq X 1.0 Lg			HPRV Cartridge, 1812 psi/125 bar
1B		Driveshaft, S 9T, 5/8" Spline			HPRV Cartridge, 2030 psi/140 bar
1C		Driveshaft, R 13T, 7/8" Spline Mobile			HPRV Cartridge, 2537 psi/175 bar
1D		Driveshaft, L 13T, 7/8" Spline Industrial			HPRV Cartridge, 2726 psi/188 bar
1E		Driveshaft, K 13T, 7/8"X 0.50 Spline			HPRV Cartridge, 3045 psi/210 bar
1F		Driveshaft, C 11T, 3/4" Spline			HPRV Cartridge, 3625 psi/250 bar
3	1	Bearing, Front Driveshaft			HPRV Cartridge, 4060 psi/280 bar
4	1	Ring, Shaft Retainer			HPRV Cartridge, 5075 psi/350 bar
5	1	Pump Housing, SAE "A" Mount, Standard	56	3	Plug, #3 HP
		Pump Housing, SAE "B" Mount, Standard	57	3	O-Ring
		Pump Housing, SAE "A" w/2 Case DR Ports	58	2	Pin, Roll
		Pump Housing, SAE "B" w/2 Case DR Ports	60	1	O-Ring
6	1	Retainer, Seal	61	2	O-Ring
7	1	Seal, Shaft	62	1	Coupling, Gerotor 0.42
10	2	Bearing, Saddle			Coupling, Gerotor 0.64
11	1	Swashblock	63	1	Ring, Retaining
12	1	Bearing, Hydrodynamic	64	1	Assembly, Gerotor Pump 0.42 Assembly, Gerotor PUMP 0.64
12A	1	Pin, Roll	65	1	KEY, Gerotor Pump 0.42 KEY, Gerotor Pump 0.64
13	1	Ring, Retainer	68A	1	Gerotor Housing, 0.42 LH T-S
14	1	Retainer, Shoe			Gerotor Housing, 0.42 RH T-S
15	7	Piston and Shoe Assembly, -011			Gerotor Housing, 0.64 LH T-S
		Piston and Shoe Assembly, -014	Gerotor Housing, 0.64 RH T-S		
		Piston and Shoe Assembly, -022	Gerotor Housing, 0.42 LH NT		
16	1	Ball, Fulcrum	68B	1	Gerotor Housing, 0.42 RH NT
17	1	Spring, Shoe Retainer			Gerotor Housing, 0.64 LH NT
18	1	Barrel, Cylinder, -011			Gerotor Housing, 0.64 RH NT
		Barrel, Cylinder, -014	IPRV Cartridge, 725 psi/050 bar		
		Barrel, Cylinder, -022	IPRV Cartridge, 914 psi/063 bar		
19	2	Pin, Roll	69	+	IPRV Cartridge, 1160 psi/080 bar
21	1	Gasket, Valve Plate			IPRV Cartridge, 1450 psi/100 bar
26	1	Nametag			70
27	2	Screw, Drive	71	1	Poppet
28	2	O-Ring	72	1	Spring, Charge (Code A,B,E)
29	1	Ring, Bearing Retainer			Spring, Charge (Code C,D,M)
50	4	Screw, SHC 0.375-16UNC X 3.5 Lg (42)			Spring, Charge (Code F,G,H,J,K,L)
		Screw, SHC 0.375-16UNC X 4.0 Lg (64)			
51	1	Valve Plate, PVWC-011 LH	76	1	Stem, Tow Valve
		Valve Plate, PVWC-011 LM	77	1	O-Ring
		Valve Plate, PVWC-011 RH	78	1	Ring, Backup
		Valve Plate, PVWC-011 RM	79	1	Bonnet, Tow Valve
		Valve Plate, PVWC-014 LH	81	1	Nut, Jam
		Valve Plate, PVWC-014 LM	83	1	Plug, Access
		Valve Plate, PVWC-014 RH	84	1	O-Ring
		Valve Plate, PVWC-014 RM	90	1	Cover Plate
		Valve Plate, PVWC-022 LH	91	1	O-Ring
		Valve Plate, PVWC-022 LM	92	4	Screw, SHC #10-24UNC X 0.38 Lg
		Valve Plate, PVWC-022 RH	93	+	Spring, 00 HPRV Option
		Valve Plate, PVWC-022 RM	94	+	Ball
52	+	Cap, Relief Valve	95	+	Plug, #8 HP
53	+	O-Ring	96	1	O-Ring
			97	2	Screw, HHC 0.375-16UNC X 1.00 Lg
			98	2	Washer, Lock

+ Quantities vary on units.

PVWC Pump Assembly With Charge Pump (con't.)

Item	Qty.	Description	Item	Qty.	Description
Pump Control Assembly			Pump Control Assembly		
303	4	Screw, SHC 0.250-20UNC X 1.0 Lg (MN/MS)	369	1	Gasket, Control
		Screw, SHC 0.250-20UNC X 1.5 Lg (CA)	370	1	Spring, CA Centering
		Screw, HHC 0.250-20UNC X 2.5 Lg (VM/VS)	372	2	Cover, VM/VS Control
332	2	O-Ring	373	1	Control Pin, MN/MS
333	2	Plug, #4 HP			Control Pin, CA
334	1	O-Ring			Control Pin, VM/VS
335	1	Neutral Switch, N.O.	374	8	Screw, SHC 0.250-20UNC X 1.00 Lg
		Neutral Switch, N.C.	375	*	O-Ring
340A	1	VM Servo Valve Assembly	376	2	O-Ring
340B		VS Servo Valve Assembly	378	1	Stem, Adjustment
341	1	O-Ring	382	2	Guide, Spring
342	4	O-Ring (VM) O-Ring (VS)	385	**	O-Ring
345	1	L.V.D.T.	390	3	Nut, Jam
347	1	Ring, Retaining	391	1	Plug, End
351	1	Stem, L.V.D.T.	392	1	Plug, #16 HP
352	2	O-Ring	393	1	Orifice, #10-24UNC w/ 0.032 dia.
356	2	O-Ring	394	1	Adjuster Cap
360	*	Plug, #8 HP	395	1	O-Ring
361	**	Plug, #2 HP	* 2 for MN/MS, 1 for VM/VS ** 2 for CA, MN/MS, 6 for VM/VS		
362	1	Arm and Pintle Assembly, MN/MS			
		Arm and Pintle Assembly, CA			
363	1	Piston, CA Control			
364	1	Piston, VM/VS Control			
368	1	Control Housing, MN			
		Control Housing, MN w/o Vol Stop			
		Control Housing, MS			
		Control Housing, MS w/o Vol Stop			
		Control Housing, CA			
		Control Housing, CA w/ Switch			
		Control Housing, VM/VS			

PARTS LIST drawings, Figures 13-B and 13-C.

SERVICE KITS

Document Number: 51837-SK1

PVWC Service Kits (with Charge Pump)

Revision: 3 (3-28-05)

Reference 51837-005 Ass'y Drwg
SERVICE KIT, Figures 13-B & 13-C

Description	Kit No.	Design Series	Items Included in Kit
Housing Kits			
SAE "A" Mount Housing & Pins Kit	K51116-100	4	5, 7 19(2), 83, 84
SAE "B" Mount Housing & Pins Kit	K51116-101	4	5, 7 19(2), 83, 84
Shaft & Bearing Kits			
7/8" Keyed Shaft & Bearing Kit (Code Y)	K51518-100	3,4	1A, 2, 3, 4, 6, 29
SAE "A" Spline Shaft & Bearing Kit (Code S)	K51518-101	3,4	1B, 3, 4, 6, 29
SAE "B" Industrial Spline Shaft & Bearing Kit (Code L)	K51518-102	3,4	1C, 3, 4, 6, 29
SAE "B" Mobile Spline Shaft & Bearing Kit (Code R)	K51518-103	3,4	1D, 3, 4, 6, 29
SAE "B" Spline Shaft & Bearing Kit (Code K)	K51518-104	3,4	1E, 3, 4, 6, 29
11T Spline Shaft & Bearing Kit (Code C)	K51518-105	3,4	1F, 3, 4, 6, 29
Seal Kits			
Gasket & Seal Kit (Pump Only)	L50827-33	1	Drwg not applicable
Gasket & Seal Kit (Pump Only)	K50827-100	3,4	7, 21, 28(2), 53(4), 57(3), 60, 61(2), 84, 91
Gasket & Seal Kit (MN or MS Control)	K50827-101	3,4	341, 356(2), 369, 375(2), 385(2)
Gasket & Seal Kit (CA Control)	K50827-102	3,4	332(2), 334, 341, 356(2), 369, 376(2), 385(2), 395
Gasket & Seal Kit (VA & VS Controls)	K50827-103	All	342(4), 352(2), 356(2), 369, 375, 385(6)
Gasket & Seal Kit (Tow Valve)	K50827-104	All	53, 77, 78
Swashblock & Control Pin Kits			
Swashblock & Control Pin Kit (MN & MS Controls)	K50488-100	4	11, 373
Swashblock & Control Pin Kit (CA Control)	K50488-101	4	11, 373
Swashblock & Control Pin Kit (VA & VS Controls)	K50488-102	4	11, 373
Saddle Bearing Kit			
	L51053-19	4	10(2)
Hydrodynamic Bearing Kit			
	K51296-100	All	12, 12A, 13
Rotating Groups			
PVWC-011 Rotating Group Kit	L50052-8C	4	14, 15(7), 16, 17, 18
PVWC-014 Rotating Group Kit	L50052-7C	4	14, 15(7), 16, 17, 18
PVWC-022 Rotating Group Kit	L50053-7C	4	14, 15(7), 16, 17, 18
Piston & Shoe Assemblies			
PVWC-011 Piston & Shoe Assemblies	L51363-900	All	15 (7)
PVWC-014 Piston & Shoe Assemblies	L50021-900	All	15 (7)
PVWC-022 Piston & Shoe Assemblies	L50021-901	All	15 (7)
Shoe Retainer & Fulcrum Ball Kits			
PVWC-011/-014 Shoe Retainer & Fulcrum Ball	L50002-3	4	14, 16
PVWC-022 Shoe Retainer & Fulcrum Ball	L50019-3	4	14, 16
Valve Plate Kits			
PVWC-011 LH w/o Tow Valve	K51630-100	4	21, 28(2), 51, 56, 57, 58(2)
PVWC-011 RH w/o Tow Valve	K51630-101	4	21, 28(2), 51, 56, 57, 58(2)
PVWC-011 LH w/ Tow Valve	K51630-102	4	21, 28(2), 51, 56, 57, 58(2)

PVWC Service Kits (with Charge Pump)

Reference 51837-005 Ass'y Drwg
SERVICE KIT, Figures 13-B & 13-C

Document Number: 51837-SK1

Revision: 3 (3-28-05)

Description	Kit No.	Design Series	Items Included in Kit
PVWC-011 RH w/ Tow Valve	K51630-103	4	21, 28(2), 51, 56, 57, 58(2)
PVWC-014 LH w/o Tow Valve	K51630-104	4	21, 28(2), 51, 56, 57, 58(2)
PVWC-014 RH w/o Tow Valve	K51630-105	4	21, 28(2), 51, 56, 57, 58(2)
PVWC-014 LH w/ Tow Valve	K51630-106	4	21, 28(2), 51, 56, 57, 58(2)
PVWC-014 RH w/ Tow Valve	K51630-107	4	21, 28(2), 51, 56, 57, 58(2)
PVWC-022 LH w/o Tow Valve	K51630-108	4	21, 28(2), 51, 56, 57, 58(2)
PVWC-022 RH w/o Tow Valve	K51630-109	4	21, 28(2), 51, 56, 57, 58(2)
PVWC-022 LH w/ Tow Valve	K51630-110	4	21, 28(2), 51, 56, 57, 58(2)
PVWC-022 RH w/ Tow Valve	K51630-111	4	21, 28(2), 51, 56, 57, 58(2)
High Pressure Relief Valve Kits			
"No HPRV, SCCV Only" Kit	K51627	All	93, 94
100 bar HPRV/SCCV Kit	51627-100	All	54
140 bar HPRV/SCCV Kit	51627-140	All	54
175 bar HPRV/SCCV Kit	51627-175	All	54
188 bar HPRV/SCCV Kit	51627-188	All	54
210 bar HPRV/SCCV Kit	51627-210	All	54
250 bar HPRV/SCCV Kit	51627-250	All	54
280 bar HPRV/SCCV Kit	51627-280	All	54
350 bar HPRV/SCCV Kit	51627-350	All	54
Charge Pressure Relief Valve Kits			
Charge Pressure RV Kit (Codes A, B, & E)	K51624-100	4	71, 72
Charge Pressure RV Kit (Codes C, D, & M)	K51624-101	4	71, 72
Charge Pressure RV Kit (Codes F, G, H, J, K, & L)	K51624-102	4	71, 72
Implement Pressure Relief Valve Kits			
50 bar Implement Pressure RV Kit	51627-050	All	69
63 bar Implement Pressure RV Kit	51627-063	All	69
80 bar Implement Pressure RV Kit	51627-080	All	69
100 bar Implement Pressure RV Kit	51627-100	All	69
Gerotor Housing Kits			
LH Thru Shaft (0.42 cipr Charge Pump)	K51631-100	4	50(4), 56(2), 57(2), 60, 61(2), 62, 63, 64, 65, 68A
RH Thru Shaft (0.42 cipr Charge Pump)	K51631-101	4	50(4), 56(2), 57(2), 60, 61(2), 62, 63, 64, 65, 68A
LH Non-Thru Shaft (0.42 cipr Charge Pump)	K51631-102	4	50(4), 56(2), 57(2), 60, 61(2), 62, 63, 64, 65, 68A
RH Non-Thru Shaft (0.42 cipr Charge Pump)	K51631-103	4	50(4), 56(2), 57(2), 60, 61(2), 62, 63, 64, 65, 68A
LH Thru Shaft (0.64 cipr Charge Pump)	K51631-104	4	50(4), 56(2), 57(2), 60, 61(2), 62, 63, 64, 65, 68A
RH Thru Shaft (0.64 cipr Charge Pump)	K51631-105	4	50(4), 56(2), 57(2), 60, 61(2), 62, 63, 64, 65, 68A
LH Non-Thru Shaft (0.64 cipr Charge Pump)	K51631-106	4	50(4), 56(2), 57(2), 60, 61(2), 62, 63, 64, 65, 68A
RH Non-Thru Shaft (0.64 cipr Charge Pump)	K51631-107	4	50(4), 56(2), 57(2), 60, 61(2), 62, 63, 64, 65, 68A
Tow Valve Kit			
	K51792-100	All	53, 76, 77, 78, 79, 81
Cover Plate Kit			
	L51634	All	90, 91, 92(4)
Adaptor Kit			
	L51081-86	All	96, 97(2), 98(2)
Name Tag & Screws			
	L50921	All	26, 27(2)

PVWC Service Kits (without Charge Pump)

Reference 51837-006 Assy Drwg
SERVICE KIT, Figures 13-A & 13-B

Document Number: 51837-SK2

Revision: 1 (11/15/04)

Description	Kit No.	Design Series	Items Included in Kit
Housing Kits			
SAE "A" Mount Housing & Pins Kit	K51116-100	4	5, 7 19(2), 83, 84
SAE "B" Mount Housing & Pins Kit	K51116-101	4	5, 7 19(2), 83, 84
Shaft & Bearing Kits			
7/8" Keyed Shaft & Bearing Kit (Code Y)	K51518-200	3,4	1A, 2, 3, 4, 6, 29
SAE "A" Spline Shaft & Bearing Kit (Code S)	K51518-201	3,4	1B, 3, 4, 6, 29
SAE "B" Industrial Spline Shaft & Bearing Kit (Code L)	K51518-202	3,4	1C, 3, 4, 6, 29
SAE "B" Spline Shaft & Bearing Kit (Code K)	K51518-203	3,4	1D, 3, 4, 6, 29
Seal Kits			
Gasket & Seal Kit (Pump Only)	K50827-200	3,4	7, 21, 28(2), 53(2), 80, 84, 91
Gasket & Seal Kit (MN & MS Controls)	K50827-101	3,4	341, 356(2), 369, 375(2), 385(2)
Gasket & Seal Kit (CA Control)	K50827-102	4	332(2), 334, 341, 356(2), 369, 376(2), 385(2), 395
Gasket & Seal Kit (VA & VS Controls)	K50827-103	All	342(4), 352(2), 356(2), 369, 375, 385(6)
Gasket & Seal Kit (Tow Valve)	K50827-201	All	77, 78, 80
Swashblock & Control Pin Kits			
Swashblock & Control Pin Kit (MN & MS Controls)	K50488-100	4	11, 373
Swashblock & Control Pin Kit (CA Control)	K50488-101	4	11, 373
Swashblock & Control Pin Kit (VA & VS Controls)	K50488-102	4	11, 373
Saddle Bearing Kit			
	L51053-19	4	10(2)
Hydrodynamic Bearing Kit			
	K51296-100	All	12, 12A, 13
Rotating Groups			
PVWC-011 Rotating Group Kit	L50052-8C	4	14, 15(7), 16, 17, 18
PVWC-014 Rotating Group Kit	L50052-7C	4	14, 15(7), 16, 17, 18
PVWC-022 Rotating Group Kit	L50053-7C	4	14, 15(7), 16, 17, 18
Piston & Shoe Assemblies			
PVWC-011 Piston & Shoe Assemblies	L51363-900	All	15 (7)
PVWC-014 Piston & Shoe Assemblies	L50021-900	All	15 (7)
PVWC-022 Piston & Shoe Assemblies	L50021-901	All	15 (7)
Shoe Retainer & Fulcrum Ball Kits			
PVWC-011/-014 Shoe Retainer & Fulcrum Ball	L50002-3	4	14, 16
PVWC-022 Shoe Retainer & Fulcrum Ball	L50019-3	4	14, 16
Valve Plate Kits (Thru Shaft)			
PVWC-011 LH w/o Tow Valve	K51630-200	4	21, 28(2), 50(4), 51A, 62, 63
PVWC-011 RH w/o Tow Valve	K51630-201	4	21, 28(2), 50(4), 51A, 62, 63
PVWC-011 LH w/ Tow Valve	K51630-202	4	21, 28(2), 50(4), 51A, 62, 63
PVWC-011 RH w/ Tow Valve	K51630-203	4	21, 28(2), 50(4), 51A, 62, 63
PVWC-014 LH w/o Tow Valve	K51630-204	4	21, 28(2), 50(4), 51A, 62, 63
PVWC-014 RH w/o Tow Valve	K51630-205	4	21, 28(2), 50(4), 51A, 62, 63
PVWC-014 LH w/ Tow Valve	K51630-206	4	21, 28(2), 50(4), 51A, 62, 63
PVWC-014 RH w/ Tow Valve	K51630-207	4	21, 28(2), 50(4), 51A, 62, 63

PVWC Service Kits (without Charge Pump)

Document Number: 51837-SK2

Reference 51837-006 Ass'y Drwg
SERVICE KIT, Figures 13-A & 13-B

Revision: 1 (11/15/04)

Description	Kit No.	Design Series	Items Included in Kit
PVWC-022 LH w/o Tow Valve	K51630-208	4	21, 28(2), 50(4), 51A, 62, 63
PVWC-022 RH w/o Tow Valve	K51630-209	4	21, 28(2), 50(4), 51A, 62, 63
PVWC-022 LH w/ Tow Valve	K51630-210	4	21, 28(2), 50(4), 51A, 62, 63
PVWC-022 RH w/ Tow Valve	K51630-211	4	21, 28(2), 50(4), 51A, 62, 63
Valve Plate Kits (Non-Thru Shaft)			
PVWC-011 LH w/o Tow Valve	K51630-220	4	21, 28(2), 50(4), 51B, 62, 63, 92, 99
PVWC-011 RH w/o Tow Valve	K51630-221	4	21, 28(2), 50(4), 51B, 62, 63, 92, 99
PVWC-011 LH w/ Tow Valve	K51630-222	4	21, 28(2), 50(4), 51B, 62, 63, 92, 99
PVWC-011 RH w/ Tow Valve	K51630-223	4	21, 28(2), 50(4), 51B, 62, 63, 92, 99
PVWC-014 LH w/o Tow Valve	K51630-224	4	21, 28(2), 50(4), 51B, 62, 63, 92, 99
PVWC-014 RH w/o Tow Valve	K51630-225	4	21, 28(2), 50(4), 51B, 62, 63, 92, 99
PVWC-014 LH w/ Tow Valve	K51630-226	4	21, 28(2), 50(4), 51B, 62, 63, 92, 99
PVWC-014 RH w/ Tow Valve	K51630-227	4	21, 28(2), 50(4), 51B, 62, 63, 92, 99
PVWC-022 LH w/o Tow Valve	K51630-228	4	21, 28(2), 50(4), 51B, 62, 63, 92, 99
PVWC-022 RH w/o Tow Valve	K51630-229	4	21, 28(2), 50(4), 51B, 62, 63, 92, 99
PVWC-022 LH w/ Tow Valve	K51630-230	4	21, 28(2), 50(4), 51B, 62, 63, 92, 99
PVWC-022 RH w/ Tow Valve	K51630-231	4	21, 28(2), 50(4), 51B, 62, 63, 92, 99
High Pressure Relief Valve Kits			
"No HPRV,SCCV Only" Kit	K51627	All	93, 94
100 bar HPRV/SCCV Kit	51627-100	All	54
140 bar HPRV/SCCV Kit	51627-140	All	54
175 bar HPRV/SCCV Kit	51627-175	All	54
188 bar HPRV/SCCV Kit	51627-188	All	54
210 bar HPRV/SCCV Kit	51627-210	All	54
250 bar HPRV/SCCV Kit	51627-250	All	54
280 bar HPRV/SCCV Kit	51627-280	All	54
350 bar HPRV/SCCV Kit	51627-350	All	54
Charge Pressure Relief Valve Kits			
Charge Pressure RV Kit (Code B)	K51626-200	4	71, 72
Charge Pressure RV Kit (Code C)	K51626-201	4	71, 72
Charge Pressure RV Kit (Code G)	K51626-202	4	71, 72
Tow Valve Kit			
	K51792-200	All	76, 77, 78, 79, 80, 81
Cover Plate Kit			
	L51634	All	90, 91, 92(4)
Adaptor Kit			
	L51081-86	All	96, 97(2), 98(2)
Name Tag & Screws			
	L50921	All	26, 27(2)

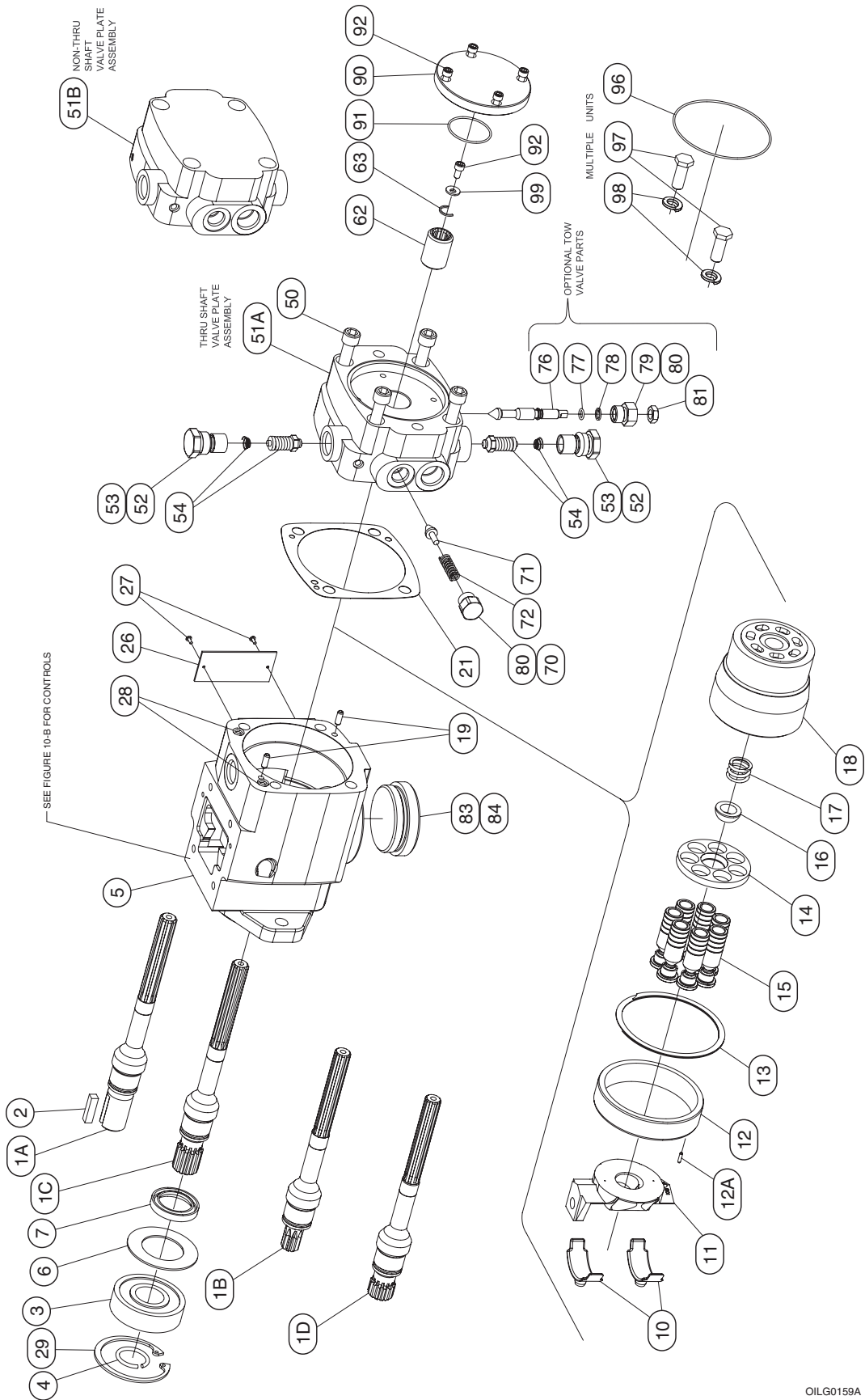

OILG0159A

Figure 13-A. Exploded Parts Drawing for PVWC Pump Assembly without Charge Pump (51837-006 sheet 1).

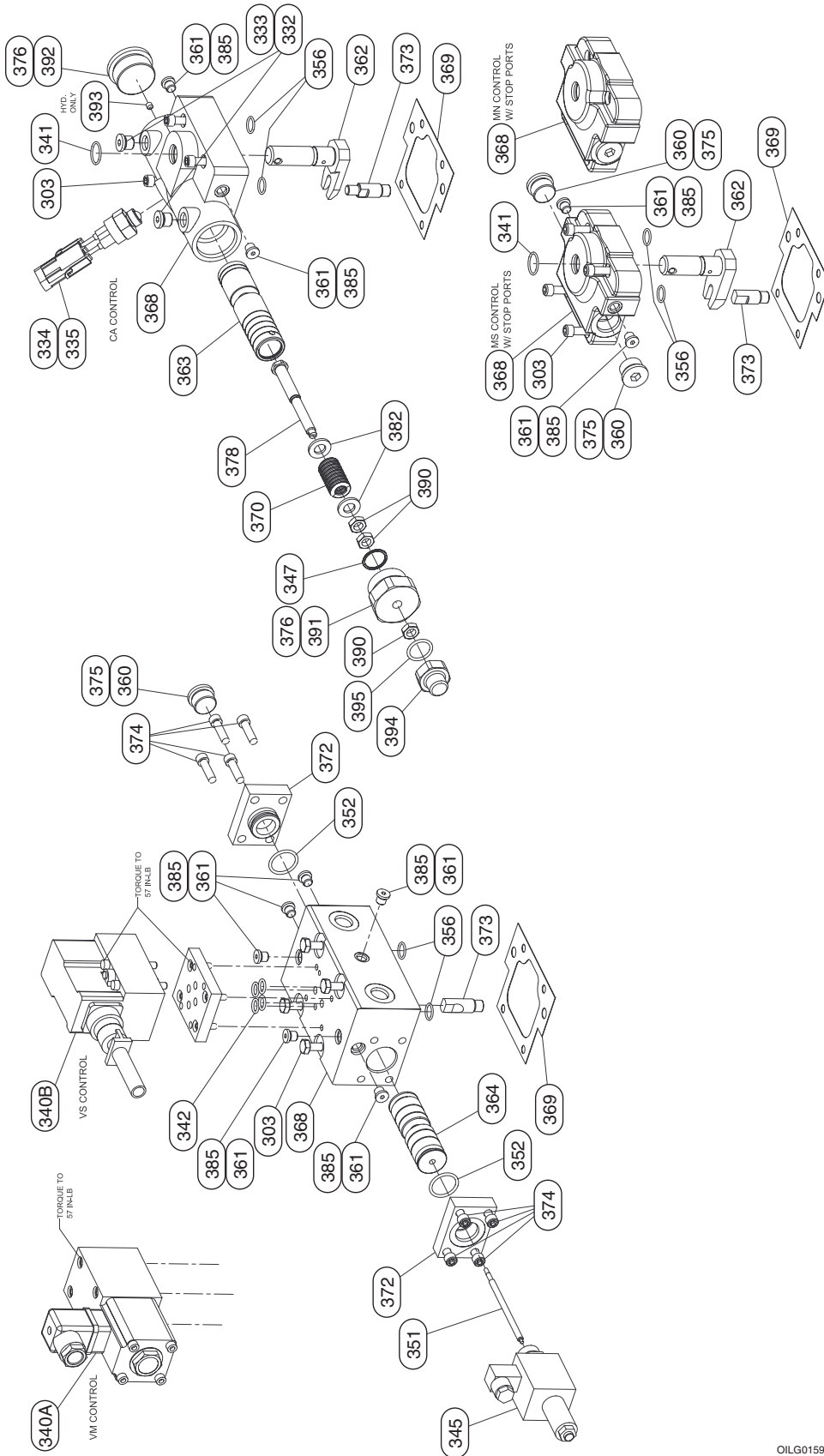

OILG0159B

Figure 13-B. Exploded Parts Drawing for PVWC Control Options (51837-005 or 51837-006, sheet 2).

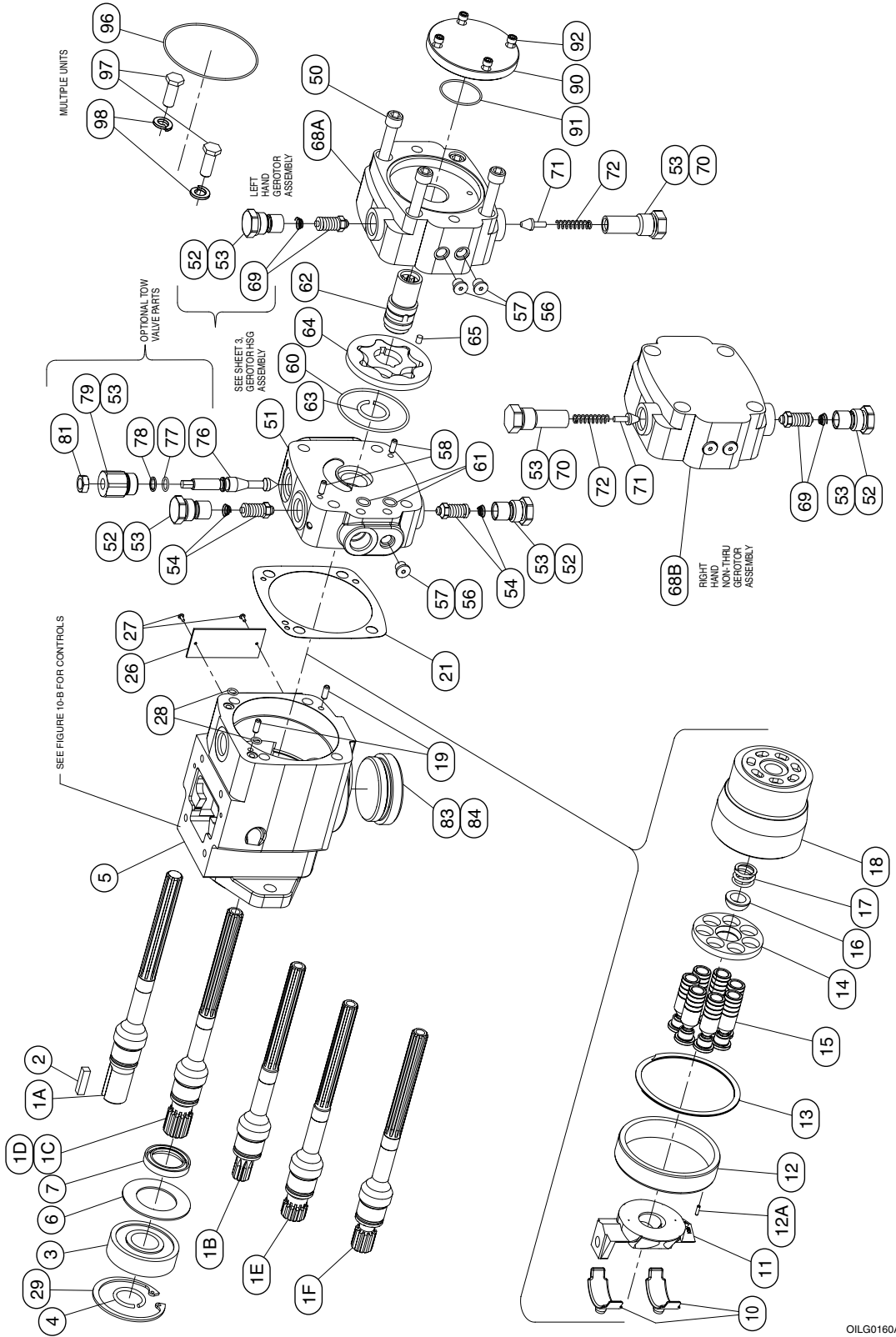

OILG0160A

Figure 13-C. Exploded Parts Drawing for PVWC with Charge Pump (51837-005 sheet 1).

AFTER SALES SERVICES

At Oilgear we build products to last. It is the nature of this type of machinery to require proper maintenance regardless of the care we put into manufacturing. Oilgear has several service programs in place to help you.

STAY-ON-STREAM SERVICE

By signing up for Oilgear's Stay-On-Stream program, you can prepare for problems before they happen. Certain field tests such as fluid testing, slip testing and electronic profile recording comparisons can be performed by our field service people or your own factory trained personnel. These tests can indicate problems before they become "down-time" difficulties.

SERVICE SCHOOLS

Oilgear conducts training to train your maintenance personnel. "General" hydraulic or electronic training is conducted at our Milwaukee, Wisconsin plant on a regular basis. "Custom" training, specifically addressing your particular hydraulic and electro-hydraulic equipment can be conducted at your facilities.

SPARE PARTS AVAILABILITY

Prepare for your future needs by stocking Oilgear original factory parts. Having the correct parts and necessary skills "in-plant" enables you to minimize "down-time." Oilgear has developed parts kits to cover likely future needs. Oilgear Field Service Technicians are also ready to assist you and your maintenance people in troubleshooting and repairing equipment.

