

# American-Lincoln®

ALTO®

Operator's  
Manual  
& Parts List

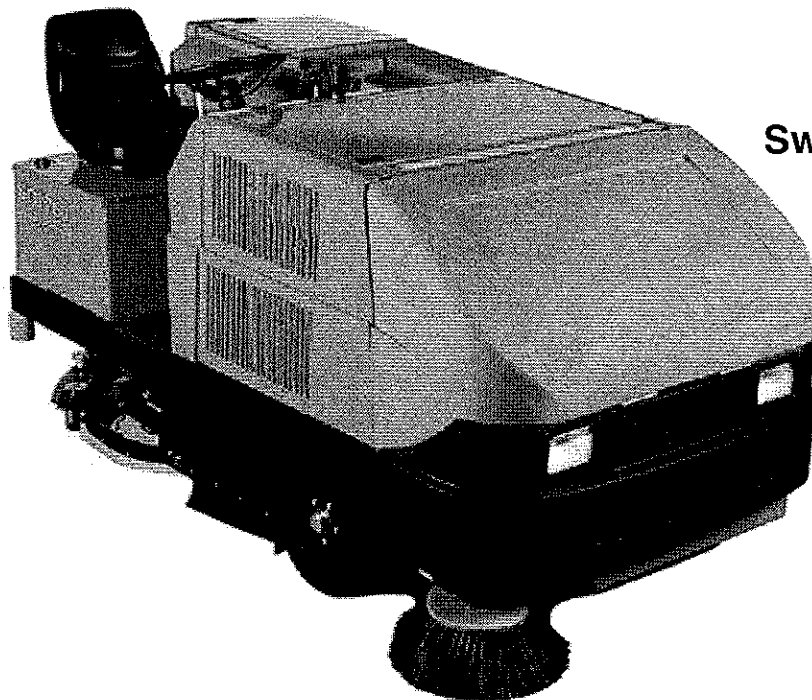

SC7750  
Sweeper/Scrubber

Beginning with Serial Number: 682128

#### READ THIS BOOK

This book has important information for the use and safe operation of this machine. Failure to read this book prior to operating or attempting any service or maintenance procedure to your machine could result in injury to you or to other personnel; damage to the machine or to other property could occur as well. You must have training in the operation of this machine before using it.

Si Ud. o sus operadores no pueden leer el Inglés, se hacen explicar este manual completamente antes de tratar el manejo o servicio de esta máquina.

All directions given in this book are as seen from the operator's position at the rear of the machine.

For new books, write to: American-Lincoln®, 1100 Haskins Road, Bowling Green, Ohio 43402





## TABLE OF CONTENTS

<b>SPECIFICATIONS</b> .....	<b>1-6</b>
<b>MACHINE DIMENSIONS</b> .....	<b>1-9</b>
<b>STANDARD HARDWARE &amp; TORQUE VALUES</b> .....	<b>1-10</b>
<b>HYDRAULIC TORQUE REQUIREMENTS</b> .....	<b>1-11</b>
<b>DECIMAL - METRIC CONVERSION TABLE</b> .....	<b>1-12</b>
<b>MACHINE PREPARATION</b> .....	<b>1-13</b>
<b>PREPARING THE MACHINE FOR OPERATION</b> .....	<b>1-13</b>
<b>BATTERY POWERED MACHINE PREPARATION</b> .....	<b>1-14</b>
<b>SAFETY INSTRUCTIONS</b> .....	<b>1-15</b>
<b>OPERATION OF CONTROLS AND GAUGES</b> .....	<b>1-18</b>
LIGHT SWITCH .....	1-18
HORN BUTTON .....	1-18
CHOKE .....	1-18
KEY SWITCH .....	1-19
ENGINE SPEED SWITCH .....	1-19
HOUR METER .....	1-19
FUEL GAUGE .....	1-19
SEAT POSITION ADJUSTMENT .....	1-19
FILTER SHAKER SWITCH .....	1-20
GLOW PLUG SWITCH .....	1-20
SEAT COMPARTMENT PROP LATCH .....	1-20
HOPPER SAFETY ARM .....	1-20
SIDE BROOM LEVER .....	1-21
SIDE BROOM ADJUSTMENT .....	1-21
MAIN BROOM LEVER .....	1-21
MAIN BROOM ADJUSTMENT .....	1-21
DUST CONTROL SWITCH .....	1-22
SCRUB DECK SWITCH .....	1-22
SCRUB DECK HEAVY PRESSURE SWITCH .....	1-22
SQUEEGEE SWITCH .....	1-22
SOLUTION CONTROL .....	1-23
NON-RECYCLING OR STANDARD SCRUBBING SYSTEM .....	1-23
RECYCLING OR ESP/AUTOFIL SYSTEM .....	1-23
DISCONNECT WATER HOSE .....	1-23
WARNING BARK .....	1-24
ENGINE TEMPERATURE LIGHT (WARNING LIGHT) .....	1-24
ENGINE OIL PRESSURE LIGHT (WARNING LIGHT) .....	1-24
CHARGING SYSTEM LIGHT (WARNING LIGHT) .....	1-24
CLOGGED FILTER LIGHT (WARNING LIGHT) .....	1-24
HOPPER TEMPERATURE LIGHT (WARNING LIGHT) .....	1-24
SOLUTION LOW LIGHT (WARNING LIGHT) .....	1-24
RECOVERY HIGH LIGHT (WARNING LIGHT) .....	1-24
FOOT BRAKE .....	1-25
PARKING BRAKE .....	1-25
FWD/REV FOOT PEDAL .....	1-25
HOPPER LIFT LEVER .....	1-26
HOPPER DUMP DOOR LEVER .....	1-26
TURN SIGNAL .....	1-27
THROTTLE .....	1-27
BACK-UP ALARM SWITCH .....	1-27
BATTERY CONDITION METER .....	1-27
FILTER PANEL LATCH .....	1-28
HOPPER TEMPERATURE SENSOR .....	1-28
ENGINE COMPARTMENT LATCH .....	1-28
HYDRAULIC RESERVOIR LEVEL SIGHT GAUGE .....	1-29
MAIN BROOM COMPARTMENT DOORS .....	1-29
SEAT COMPARTMENT COVER .....	1-29
HOPPER DOOR LEVER .....	1-30
HOPPER LIFT LEVER .....	1-30
HOPPER FILTER COMPARTMENT COVER .....	1-30

# TABLE OF CONTENTS

<b>ESP SYSTEM OPERATING INSTRUCTIONS</b> .....	<b>1-31</b>
ESP RECYCLING CONTROL PANEL .....	1-31
ESP RECYCLING SYSTEM ON/OFF SWITCH .....	1-31
DETERGENT FLOW KNOB .....	1-31
HOPPER SAFETY LOCK ARM .....	1-31
THE SCRUBBING SYSTEM - HOW IT WORKS .....	1-32
THE NON-RECYCLING OR STANDARD SCRUBBING SYSTEM - HOW IT WORKS .....	1-32
RECOVERY OR ESP SYSTEM - HOW IT WORKS .....	1-33
THE VARI DUMP SWEEPING & DUST CONTROL SYSTEMS - HOW THEY WORK .....	1-33
<b>OPERATING INSTRUCTIONS</b> .....	<b>1-34</b>
DUST CONTROL .....	1-34
BEFORE STARTING THE ENGINE .....	1-34
PRE-START CHECKLIST .....	1-34
STARTING BATTERY MACHINES .....	1-35
STARTING GAS ENGINES .....	1-35
STARTING PROPANE ENGINES .....	1-35
STARTING DIESEL ENGINES .....	1-35
EMPTYING THE DEBRIS HOPPER .....	1-35
POST-OPERATION CHECKLIST .....	1-36
BATTERY CHARGING INSTRUCTIONS .....	1-36
<b>MACHINE STORAGE</b> .....	<b>1-36</b>
GASOLINE POWERED MACHINES .....	1-36
BATTERY POWERED MACHINES .....	1-36
<b>HELPFUL HINTS FOR CLEANING OPERATION</b> .....	<b>1-37</b>
<b>SERVICE CHART</b> .....	<b>1-38</b>
<b>SERVICE PRECAUTIONS</b> .....	<b>1-40</b>
<b>SERVICE INSTRUCTIONS</b> .....	<b>1-41</b>
<b>MAIN BROOM</b> .....	<b>1-41</b>
CHECKING THE MAIN BROOM SWEEP PATTERN .....	1-41
ADJUSTING THE MAIN BROOM HEIGHT .....	1-41
REPLACING THE MAIN BROOM .....	1-41
MAIN BROOM LEVEL ADJUSTMENT .....	1-41
<b>SIDE BROOM</b> .....	<b>1-42</b>
CHECKING THE SIDE BROOM SWEEP PATTERN .....	1-42
ADJUSTING THE SIDE BROOM HEIGHT .....	1-42
REPLACING THE SIDE BROOM .....	1-42
<b>HOPPER SERVICE</b> .....	<b>1-43</b>
HOPPER .....	1-43
CLEANING THE HOPPER .....	1-43
CHECKING THE HOPPER SEALS .....	1-43
<b>DUST CONTROL FILTER</b> .....	<b>1-43</b>
CHECKING THE DUST CONTROL FILTER .....	1-43
CLEANING THE DUST CONTROL FILTER .....	1-43
REPLACING THE DUST CONTROL FILTER .....	1-44
<b>DUST FLAPS</b> .....	<b>1-44</b>
CHECKING THE DUST FLAPS .....	1-44
ADJUSTING THE DUST FLAPS .....	1-44
<b>BRAKES</b> .....	<b>1-45</b>
ADJUSTING THE BRAKE PEDAL .....	1-45
ADJUSTING THE BRAKES .....	1-45
<b>GENERAL MACHINE MAINTENANCE</b> .....	<b>1-45</b>
FILLING THE HYDRAULIC RESERVOIR .....	1-46
CLEANING THE HYDRAULIC SYSTEM .....	1-46
REPLACING THE RETURN FILTER ELEMENT .....	1-46
REPLACING THE SCRUB BRUSH .....	1-47
COVERS AND LATCHES .....	1-47
SOLUTION LOW WARNING LIGHT .....	1-47
RECOVERY HIGH WARNING LIGHT .....	1-47

**TABLE OF CONTENTS**

SOLUTION CONTROL .....	1-47
RECYCLING PUMP ESP SYSTEM .....	1-48
RECYCLING PUMP STORAGE .....	1-48
REAR SQUEEGEE .....	1-48
SQUEEGEE CASTER WHEELS .....	1-48
ADJUSTING CASTERS .....	1-48
AIR INTAKE SYSTEM .....	1-49
AIR FILTER .....	1-49
REPLACING THE AIR FILTER ELEMENT .....	1-50
REMOVING THE AIR FILTER ELEMENT .....	1-50
CLEANING THE AIR FILTER ELEMENT .....	1-50
INSPECTING THE AIR FILTER ELEMENT .....	1-51
DUST CAP .....	1-51
COOLING SYSTEM .....	1-51
COOLANT LEVEL .....	1-51
RADIATOR .....	1-51
DRIVE BELTS .....	1-52
BATTERY .....	1-52
GAS TANK .....	1-52
<b>LP GAS SYSTEM .....</b>	<b>1-53</b>
LP GAS VAPORIZER - REGULATOR QUICK CHECK .....	1-53
LP FUEL TANK .....	1-53
NEUTRALADJUSTMENT .....	1-53
LP SAFETY PRECAUTIONS .....	1-54
LP LIQUID WITHDRAWAL SYSTEM .....	1-55
LP CHECKLIST .....	1-56
LP FUEL TANKS .....	1-56
LP TANK CARE .....	1-56
USE AND CARE OF LP TANKS .....	1-56
CHANGING THE LP TANKS .....	1-57
STORING LP FUEL TANKS .....	1-57
<b>PARTS LIST LEGEND .....</b>	<b>1-58</b>
<b>GENERAL TROUBLESHOOTING .....</b>	<b>1-59</b>
<b>ORDERING PARTS .....</b>	<b>1-61</b>
<b>CHAPTER 2 PARTS .....</b>	<b>2-4</b>
MAIN BROOM LEVER .....	2-4
SIDE BROOM - BATTERY .....	2-6
SIDE BROOM .....	2-7
SIDE BROOM PULLEY .....	2-8
SIDE BROOM LEVER .....	2-10
SIDE BROOM LIFT SYSTEM-BATTERY .....	2-12
SIDE BROOM LIFT SYSTEM-GAS .....	2-14
BROOM CHAMBER FLAPS & SEALS .....	2-16
LOWER DOOR .....	2-18
HOPPER (VARIABLE DUMP) .....	2-20
HOPPER LID/COVER (VARIABLE DUMP) .....	2-24
HOPPER DUMP DOOR .....	2-25
HOPPER DOOR CYLINDER-GAS .....	2-26
HOPPER DOOR CYLINDER-BATTERY .....	2-27
HOPPER CONTROL VALVE - BATTERY (VARIABLE DUMP) .....	2-28
HOPPER CONTROL VALVE - GAS (VARIABLE DUMP) .....	2-29
SCRUB DECK (46") - BATTERY .....	2-30
SCRUB DECK (46") - GAS .....	2-33
SCRUB DECK & SQUEEGEE (53") - BATTERY .....	2-36
SCRUB DECK & SQUEEGEE (53") - GAS .....	2-44
SIDE SQUEEGEES (46") .....	2-48
REAR SQUEEGEES (46") .....	2-49
SQUEEGEE LIFT - BATTERY .....	2-50
SQUEEGEE LIFT - GAS .....	2-52

## TABLE OF CONTENTS

SWING SQUEEGEE SUPPORT .....	2-54
SOLUTION TANK .....	2-56
SOLUTION FEED .....	2-58
RECOVERY TANK .....	2-60
RECOVERY DRAIN SYSTEM .....	2-62
FRONT BUMPER .....	2-63
FRONT WHEEL .....	2-64
WHEEL WELL FLAP .....	2-65
REAR WHEEL ASSEMBLY .....	2-66
BRAKE PEDAL .....	2-68
FORWARD/REVERSE CONTROL - BATTERY .....	2-70
FORWARD/REVERSE CONTROL - GAS .....	2-72
FRAME .....	2-74
STEERING COLUMN .....	2-76
VAC FAN - BATTERY .....	2-78
VAC FAN - GAS .....	2-79
VAC MOTOR MANIFOLD .....	2-80
SAFETY ARM .....	2-81
FILTER SHAKER .....	2-82
CONSOLE .....	2-84
SEAT AND FLOOR ASSEMBLY .....	2-86
PUMP ASSEMBLY, WHEEL DRIVE - BATTERY .....	2-88
HYDRAULIC TUBES .....	2-92
HYDRAULICS MAIN BROOM .....	2-93
HYDRAULIC HOSE DIAGRAM - GAS (VARIABLE DUMP) .....	2-94
HYDRAULIC HOSE DIAGRAM - BATTERY (VARIABLE DUMP) .....	2-96
SIDE BROOM HYDRAULICS .....	2-98
HOPPER LIFT HYDRAULICS .....	2-99
HOPPER DUMP DOOR HYDRAULICS .....	2-100
HOPPER CONTROL CHECK VALVE HYDRAULICS - GAS (VARIABLE DUMP) .....	2-101
SCRUB DECK HYDRAULICS .....	2-102
SCRUB DECK LIFT HYDRAULICS - BATTERY .....	2-103
SCRUB DECK LIFT HYDRAULICS - GAS .....	2-104
SQUEEGEE LIFT HYDRAULICS .....	2-105
HYDRAULIC RESERVOIR - BATTERY .....	2-106
HYDRAULIC RESERVOIR (PISTON PUMP) .....	2-108
WHEEL DRIVE HYDRAULICS .....	2-110
HYDRAULIC FORWARD/REVERSE VALVE .....	2-111
HYDRAULIC PUMP - GAS .....	2-112
HYDRAULIC MAIN CONTROL VALVE - GAS .....	2-114
HYDRAULIC CYLINDER CONTROL VALVE - GAS .....	2-116
HYDRAULIC RETURN BLOCK .....	2-118
VAC FAN HOPPER HYDRAULICS .....	2-120
STEERING 90° - 90° HYDRAULICS .....	2-121
ENGINE COVERS - BATTERY .....	2-122
ENGINE COVERS - GAS .....	2-124
FUEL TANK - GAS .....	2-126
FUEL TANK - LP .....	2-128
FUEL TANK - DIESEL .....	2-132
FUEL SYSTEM - LP .....	2-134
FUEL SYSTEM - DIESEL .....	2-136
FORD 413 GAS ENGINE .....	2-138
FORD 413 LP ENGINE .....	2-140
PERKINS DIESEL ENGINE .....	2-142
MUFFLER - GAS/LP .....	2-144
MUFFLER - DIESEL .....	2-146
RADIATOR AND SHROUD - GAS .....	2-148
RADIATOR AND SHROUD - DIESEL .....	2-149
ELECTRICAL ASSEMBLY - BATTERY .....	2-150
BATTERY ELECTRICAL ASSEMBLY - GAS/LP/DIESEL .....	2-152
INSTRUMENT PANEL - BATTERY .....	2-154
ELECTRICAL HARNESS ROUTING - BATTERY .....	2-156

## TABLE OF CONTENTS

ELECTRICAL HARNESS ROUTING - GAS .....	2-157
ELECTRICAL HARNESS ROUTING - DIESEL .....	2-158
THROTTLE CONTROL .....	2-159
DECALS .....	2-160
NOTES .....	2-162
ELECTRICAL SCHEMATIC (BATTERY) .....	2-163
ELECTRICAL SCHEMATIC (GAS) .....	2-164
ELECTRICAL SCHEMATIC (DIESEL) .....	2-165
MACHINE CONNECTION DIAGRAM (BATTERY) .....	2-166
MACHINE CONNECTION DIAGRAM (GAS) .....	2-167
MACHINE CONNECTION DIAGRAM (DIESEL) .....	2-168
INSTRUMENT PANEL CONNECTION DIAGRAM (GAS/DIESEL) .....	2-169
FLOOR PANEL CONNECTION DIAGRAM (GAS/DIESEL) .....	2-170
INSTRUMENT PANEL CONNECTION DIAGRAM (BATTERY) .....	2-171
FLOOR PANEL CONNECTION DIAGRAM (BATTERY) .....	2-172
POWER PANEL CONNECTION DIAGRAM (BATTERY) .....	2-173
HYDRAULICS SCHEMATIC (BATTERY) .....	2-174
HYDRAULICS SCHEMATIC (GAS/DIESEL) .....	2-175
<b>CHAPTER 3 OPTIONS .....</b>	<b>3-3</b>
ROLL-OUT BATTERY (800 AH OPTION) .....	3-3
BRUSHES OPTION .....	3-4
HOPPER THERMO-SENSOR SHUTDOWN OPTION .....	3-6
BACK-UP ALARM OPTION .....	3-8
REAR WORK LIGHT OPTION .....	3-10
OVERHEAD GUARD OPTION .....	3-11
AMBER SAFETY LIGHT OPTION WITH OVERHEAD GUARD .....	3-12
AMBER SAFETY LIGHT OPTION WITHOUT OVERHEAD GUARD .....	3-13
ESP/AUTOFIL OPTION .....	3-14
ESP/AUTOFIL WIRING - BATTERY .....	3-20
ESP/AUTOFIL WIRING - GAS .....	3-22
FIRE EXTINGUISHER .....	3-24
FLAME ARRESTING GAS CAP .....	3-25
HEAVY DUTY AIR CLEANER OPTION .....	3-26
CLOGGED FILTER OPTION .....	3-27
SPRAY WAND OPTION .....	3-28
WET SWEEP BYPASS/THERMO SENSOR OPTION .....	3-32
LP OPTION - TANK ASSEMBLY .....	3-36
LP OPTION - REGULATOR/LOCK-OFF ASSEMBLY .....	3-38
LP OPTION - RELIEF VALVE ASSEMBLY .....	3-40
LP OPTION - CARBURETOR ASSEMBLY .....	3-42
RETRACTABLE SEATBELT OPTION .....	3-44
SUSPENSION SEAT OPTION .....	3-45
SEAT SWITCH KIT .....	3-46
PAD DRIVER OPTION (16") .....	3-47
PAD DRIVER OPTION (18") .....	3-48
OIL COOLER OPTION .....	3-49
VACUUM WAND OPTION .....	3-50
VAC HOSE SERVICE KIT .....	3-51
SPARE PARTS - SC7750 MACHINE .....	3-52
SPARE PARTS LIST - SC7750 MACHINE .....	3-53
SPARE PARTS LIST - SC7750 BATTERY MACHINE .....	3-54
SPARE PARTS LIST - SC7750 BATTERY MACHINE .....	3-55
SPARE PARTS LIST - GAS/LP MACHINE .....	3-56
INDEX .....	3-57
WARRANTY .....	3-63

## SPECIFICATIONS

---

### CLEANING PATH

Scrubbing	46 Inches (116.84 cm) or 53" (134.62cm)
Sweeping	60 Inches (152.40 cm) Variable Dump
Edge Cleaning	6 Inches (15.24 cm) Right Side 53 Inches (134.62 cm) Only

### TRAVEL SPEED

0-6 MPH

### STEERING

Rack & Pinion 90°-90° Hydraulic Power Steering  
Adjustable Steering Column

### TURNING RADIUS

Left	74.5 Inches (189.23 cm)
Right	74.5 Inches (189.23 cm)
Aisle "U" Turn	110.0 Inches (279.40 cm)

### DIMENSIONS

Length	102.5 Inches (265.43 cm)
Width	55.0 Inches (132.08 cm)
Height	55.5 Inches (140.97 cm)
Height w/ Overhead Guard	78.75 Inches (197.49 cm)
Wheel Base	50.8 Inches (128.90 cm)

### WEIGHT

Standard Machine (Gas)	2900 lbs. (1305.0 Kg)
Standard Machine (Battery)	2600 lbs. (1170.0 Kg) Less Battery

### TIRES

Type, Gas	Solid Rubber (Front & Rear)
Front, Battery (Urethane)	Two (2) 16" (41cm) x 3.75" (8.26 cm)
Rear	One (1) 16" (41 cm) x 4.00" (10.16 cm)

### RAMP CLIMBING

Sweeping	6 Degrees (Gas & Diesel); 3 Degrees (Batt.)
Transporting	8 Degrees (Gas & Diesel); 6 Degrees (Batt.)

### ENGINE DATA

Ford 413 Engine	
Bore and Stroke	2.91" x 2.97" (7.39 cm x 7.54 cm)
Oil Capacity	3.5 Quarts (3.25 Liters)
Displacement	4 Cylinders - 1.3 Liters (79CID)
Fuel	Regular Unleaded Gasoline

Perkins 104.19 Diesel	
Bore and Stroke	3.307" x 3.543" (8.4 cm x 9.0 cm)
Oil Capacity	6.5 Quarts (6.2 Liters)
Displacement	4 Cylinders 2 Liters (122 CID)
Fuel	Minimum Cetane Number 40



**SPECIFICATIONS**

**MAIN BROOM**

One piece plastic core disposable type. Broom position can be set to "restricted down" or "free floating."

Length	45 Inches (114 cm)	
Diameter	14 Inches (35.6 cm)	
Bristle Length	3.25 Inches (8.26 cm)	
Optional Bristle Type	Nylon (Herringbone)	Proex and Wire
	High Density Nylon	Poly and Wire
Main Broom Lift	Hard Linkage	
Main Broom Arms	Patented (No Tool Broom Change)	

**SIDE BROOM**

Side Broom Size	21 Inch (53.34 cm) Diameter
Side Broom Bracket	Swing Away Shock Mount
Side Broom Lift	Cable

**INSTRUMENTS AND CONTROLS**

Fuel Gauge	Main Broom Lever (Activates Immediately when lowered)
Key Switch	Rectangular Hour Meter
Headlight/Taillight Switch	Side Broom Lever (Activates Immediately when lowered)
2-Position Throttle Switch	Engine Oil Pressure Light
Squeegee Switch	Recovery High Light
Scrub Deck Switch	Clogged Filter Light (OPTION)
Scrub Deck Heavy Load Switch (Gas & Diesel)	
Hopper Temperature Light (OPTION)	Glow Plug (Diesel)
Solution Low Light	Solution Control
Coolant Temperature Light	Hopper Up/Down
Charging System Light (Gas & Diesel)	Dump Door Open/Closed
Choke (Gas)	Filter Shaker Switch
Horn Button	Dust Control Switch (Battery)

**SCRUBBING SYSTEM**

Brush Size-46"	Three (3) 16" (40.64 cm) Diameter Brushes
Brush Size-53"	Three (3) 17.88" (45.42 cm) Diameter Brushes
Brush Drive	Hydraulic Motors, Off in Neutral (after 2 second delay)
Brush Drive Lift	Hydraulic Cylinder
Scrub Load	Ground Clearance
	250 lbs. (112.50 Kg) or 400 lbs. (180.0 Kg)

**SQUEEGEE**

Vacuum/Squeegee	55.5 Inch (140.97 cm) Wide Swing, Gum Rubber Outer Blade
Side Squeegees (2)	Patented Configuration
Squeegee Lift	Cylinder and Cable, Auto Lift in Reverse
Squeegee Hose	2 Inch (5.08 cm) Diameter

**TANKS**

Solution Tank	70 Gallon (264.96 Liters) Polyethylene
Recovery Tank	70 Gallon (264.96 Liters) Polyethylene
Solution Metering	Variable to 3.0 GPM

## SPECIFICATIONS

---

### HOPPER

Capacity	10 Cubic Feet (.2832 Cubic Meters), 700 lbs. (315 Kg)
Dump and Lift	Variable Dump with Dump Door
Filter	78 Sq. Ft. (72,464 Sq. Cm)
Dump Height	60-Inch (152.40 cm) Variable Dump;
Reach Into Dumpster	11 Inches (27.94 cm)

### SYSTEM FLUID CAPACITIES

Fuel Tank	10.0 Gallons (37.95 Liters)
Hydraulic System(Gas & Diesel)	9.0 Gallons (34.07 Liters) Swing Out for Service (Gas & Diesel)
Hydraulic System (Battery)	4.0 Gallons (15.16 Liters)

### OPTIONAL EQUIPMENT

Seat Belt	Back Up Alarm
Wet Sweep Bypass/Thermo-Sensor	Push Pull Light Switch (Work Light) (Variable Dump Only)
Amber Safety Light	Headlight/Taillight Switch
ESP & Autofill Recycling System	Overhead Guard
Pad Drivers	Non-Marking Tires
Oil Cooler (Gas Only)	Scrub Brushes
46" Scrub Option (Field Installed) (Gas )	53" Scrub Option (Field Installed) (Gas)
LP Option	Vacuum Wand Option
Spray Wand Option	Clogged Filter
Fire Extinguisher	Heavy Duty Air Cleaner (Gas )
Roll Out Battery (Battery Only)	

# MACHINE DIMENSIONS

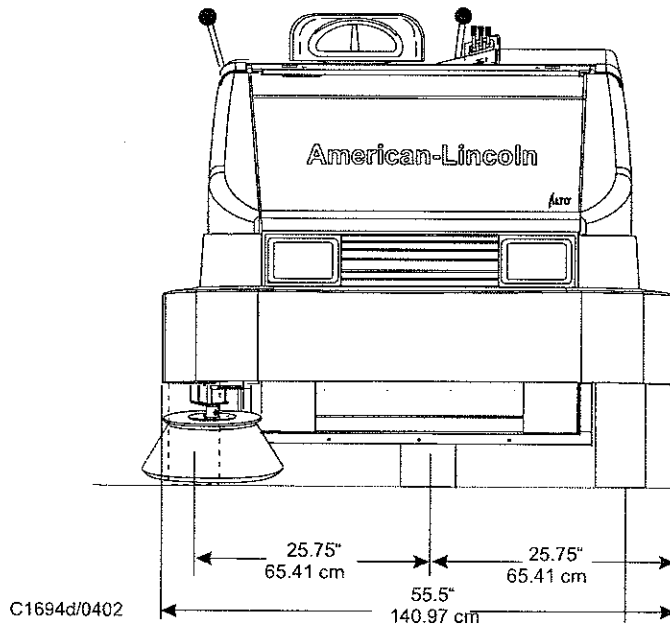
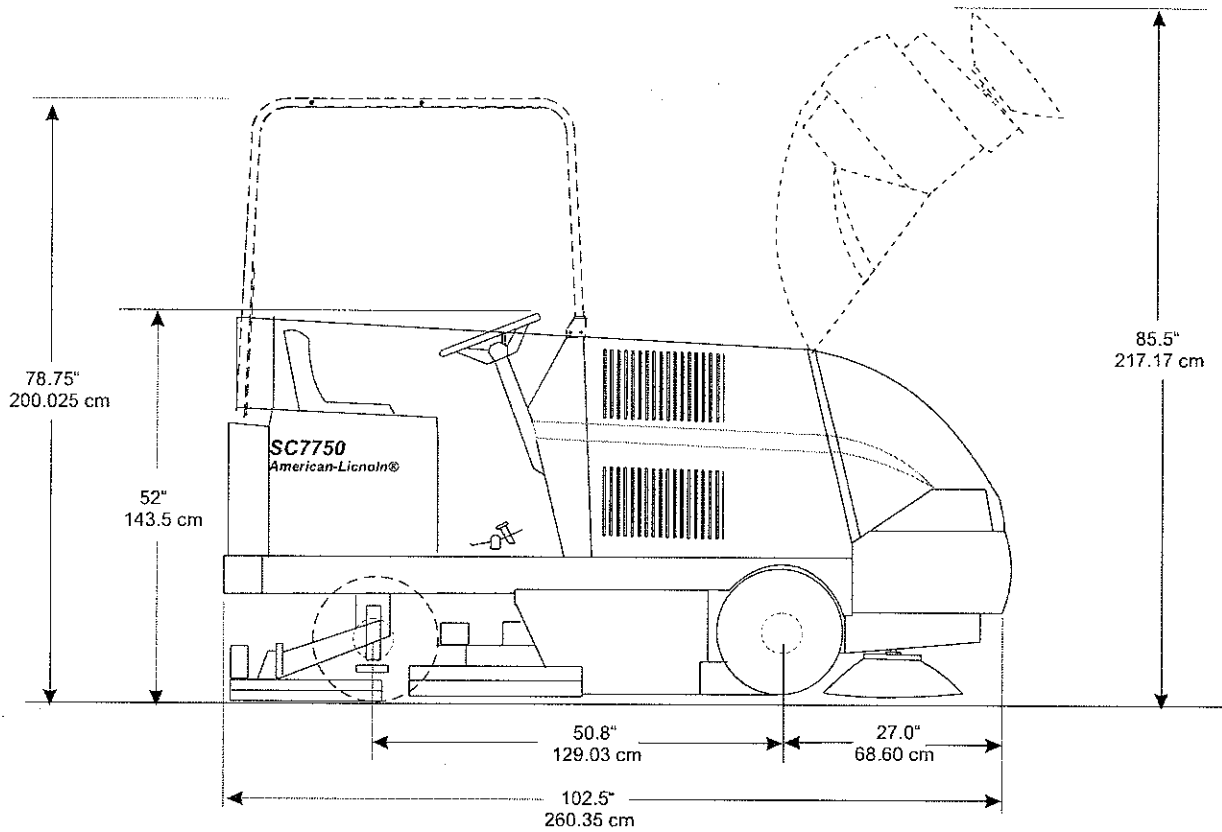

**STANDARD HARDWARE & TORQUE VALUES**

**BOLT IDENTIFICATION**

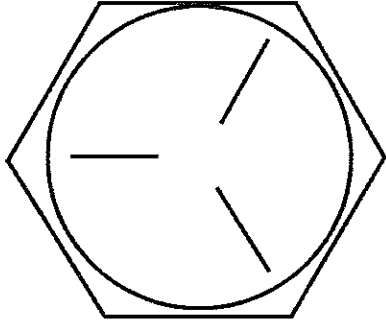

SAE - Grade 5

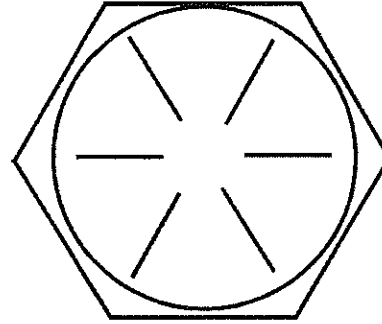

SAE - Grade 8

Screw Size	Grade 5 Plated		Grade 8 Plated		410H Stainless		Brass	Type F & T & BT		Type B, AB
	C	F	C	F	C	F		C	F	
*6	14	15	-	-	18	20	5	20	23	21
*8	27	28	-	-	33	35	9	37	41	34
*10	39	43	-	-	47	54	13	49	64	49
*1/4	86	108	130	151	114	132	32	120	156	120
5/16	15	17	22	24	19	22	6	-	-	-
3/8	28	31	40	44	34	39	10	-	-	-
7/16	44	49	63	70	55	62	16	-	-	-
1/2	68	76	95	108	85	95	-	-	-	-
9/16	98	110	138	155	-	-	-	-	-	-
5/8	135	153	191	216	-	-	-	-	-	-
3/4	239	267	338	378	-	-	-	-	-	-
7/8	387	-	545	-	-	-	-	-	-	-
1	579	-	818	-	-	-	-	-	-	-

C = Coarse Thread

F = Fine Thread

\* = Torque values for #6 through 1/4 are lb./in. All others are lb./ft.

**NOTE**

Decrease the torque by 20% when using thread lubricant  
The torque tolerance is  $\pm$  on torque values.

+

C2000/9905

## HYDRAULIC TORQUE REQUIREMENTS

### HYDRAULIC TORQUE REQUIREMENTS

Refer to the following chart for torque values on all hydraulic hoses and fittings.

Nominal SAE Dash Size	O-Ring Face Seal End		SAE O-Ring Boss End	
	Thread Size Inch	Swivel Nut Torque	Thread Size Inch	Str. Fitting or Locknut Torque
		LB-FT		LB-FT
-3	*	*	3/8-24	8-10
-4	9/16-18	10-12	7-16-20	14-16
-5	*	*	1/2-20	18-20
-6	11/16-16	18-20	9/16-18	24-25
-8	13/16-16	32-35	3/4-16	50-60
-10	1-14	46-50	7/8-14	72-80
-12	1 3/16-12	65-70	1 1/16-12	125-135
-14	1 3/16-12	65-70	1 3/16-12	160-180
-16	1 7/16-12	92-100	1 5/16-12	200-220
-20	1 11/16-12	125-140	1 5/8-12	210-280
-24	2-12	150-165	1 7/8-12	270-360

\* O-Ring face seal type end not defined for this tube size.

**NOTE**

**Parts must be lightly oiled with hydraulic fluid.**

C-2002

# DECIMAL-METRIC CONVERSION TABLE

## DECIMAL-METRIC CONVERSION TABLE

Fraction	Decimal	Millimeter	Fraction	Decimal	Millimeter
$\frac{1}{64}$	0.015625	0.3969	$\frac{33}{64}$	0.515625	13.0969
$\frac{1}{32}$	0.03125	0.7938	$\frac{17}{32}$	0.53125	13.4938
$\frac{3}{64}$	0.046875	1.1906	$\frac{35}{64}$	0.546875	13.8906
$\frac{1}{16}$	0.0625	1.5875	$\frac{9}{16}$	0.5625	14.2875
$\frac{5}{64}$	0.078125	1.9844	$\frac{37}{64}$	0.578125	14.6844
$\frac{3}{32}$	0.09375	2.3813	$\frac{19}{32}$	0.59375	15.0813
$\frac{7}{64}$	0.109375	2.7781	$\frac{39}{64}$	0.609375	15.4781
$\frac{1}{8}$	0.125	3.1750	$\frac{5}{8}$	0.625	15.8750
$\frac{9}{64}$	0.140625	3.5719	$\frac{41}{64}$	0.640625	16.2719
$\frac{5}{32}$	0.15625	3.9688	$\frac{21}{32}$	0.65625	16.6688
$\frac{11}{64}$	0.171875	4.3656	$\frac{43}{64}$	0.671875	17.0656
$\frac{3}{16}$	0.1875	4.7625	$\frac{11}{16}$	0.6875	17.4625
$\frac{13}{64}$	0.203125	5.1594	$\frac{45}{64}$	0.703125	17.8594
$\frac{7}{32}$	0.21875	5.5563	$\frac{23}{32}$	0.71875	18.2563
$\frac{15}{64}$	0.234375	5.9531	$\frac{47}{64}$	0.734375	18.6531
$\frac{1}{4}$	0.25	6.3500	$\frac{3}{4}$	0.75	19.0500
$\frac{17}{64}$	0.265625	6.7469	$\frac{49}{64}$	0.765625	19.4469
$\frac{9}{32}$	0.28125	7.1438	$\frac{25}{32}$	0.78125	19.8438
$\frac{19}{64}$	0.296875	7.5406	$\frac{51}{64}$	0.796875	20.2406
$\frac{5}{16}$	0.3125	7.9375	$\frac{13}{16}$	0.8125	20.6375
$\frac{21}{64}$	0.328125	8.3344	$\frac{53}{64}$	0.828125	21.0344
$\frac{11}{32}$	0.34375	8.7313	$\frac{27}{32}$	0.84375	21.4313
$\frac{23}{64}$	0.359375	9.1281	$\frac{55}{64}$	0.859375	21.8281
$\frac{3}{8}$	0.375	9.5250	$\frac{7}{8}$	0.875	22.2250
$\frac{25}{64}$	0.390625	9.9219	$\frac{57}{64}$	0.890625	22.6219
$\frac{13}{32}$	0.40625	10.3188	$\frac{29}{32}$	0.90625	23.0188
$\frac{27}{64}$	0.421875	10.7156	$\frac{59}{64}$	0.921875	23.4156
$\frac{7}{16}$	0.4375	11.1125	$\frac{15}{16}$	0.9375	23.8125
$\frac{29}{64}$	0.453125	11.5094	$\frac{61}{64}$	0.953125	24.2094
$\frac{15}{32}$	0.46875	11.9063	$\frac{31}{32}$	0.96875	24.6063
$\frac{31}{64}$	0.484375	12.3031	$\frac{63}{64}$	0.984375	25.0031
$\frac{1}{2}$	0.5	12.7000	1	1.0000	25.4000

C-2001

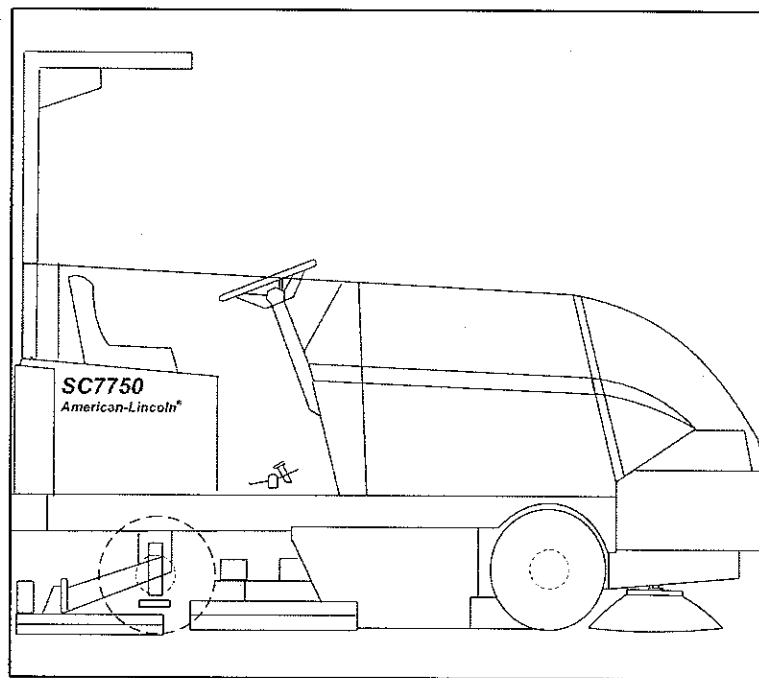

C1694c

FIGURE 1

YOUR SC7750 MACHINE HAS BEEN SHIPPED COMPLETE, BUT DO NOT ATTEMPT TO OPERATE WITHOUT FOLLOWING THESE INSTRUCTIONS.

### PREPARING THE MACHINE FOR OPERATION (IC Engine Powered)

1. Connect and tighten battery cables.
2. Fill the tank with REGULAR GRADE gasoline. (Diesel fuel if equipped with diesel engine.)



### WARNING

Never fill the tank while the engine is running. Always be sure the gasoline container and sweeper are electrically connected before pouring gasoline. This can easily be done by providing an insulated wire (permanently attached to container) with a battery clip on the other end.

3. Check engine crankcase oil level. Although properly lubricated at the factory, check before starting the engine. No special break-in oil is used and recommended number of operating hours before the initial oil change is the same as normal. See Maintenance.
4. Check radiator coolant level. Permanent type antifreeze is added at the factory to provide protection to approximately -35°F (37°C). To retain this protection level, always add ½ part water to ½ part antifreeze.
5. Check oil level in the hydraulic reservoir located at the center of the machine beside the engine. The oil fill level should be halfway on sight glass. If oil is needed, add HYDRAULIC FLUID ONLY, automatic transmission fluid FORD type "F." After the first 50 operating hours, service must be performed on your engine to ensure future high performance and trouble free operation. See Maintenance.

## MACHINE PREPARATION - BATTERY

---

### NOTE

After the first 35 operating hours, service must be performed on your engine to ensure future high performance and trouble free operation. See Maintenance.

### BATTERY POWERED MACHINES

- \*Uncrate the machine and carefully remove from skid to prevent damage.
- \*The SC7750 machines that are shipped without batteries have the (+) positive drive motor lead disconnected.
- \*Open the battery compartment and connect the (+) positive motor lead to the top terminal post (the wire "P" is also attached to it). Tighten the terminal nut.
- \*Install the scrub brushes.
- \*Check the oil level in the hydraulic reservoir
- \*Install batteries as follows (if not included):
  1. Turn the key to the "OFF" position.
  2. Raise the Solution Cover to the open position.
  3. Use a battery lifting device with a 2500 lbs. (1150 Kg) capacity hoist to lift the battery.
  4. Using the lifting device, lower the 36 volt battery into the battery compartment directly in front of the driver's compartment. Orient the cables & plug them in as required.
  5. Plug the polarized connector from the battery into the 36 volt plug provided.



### WARNING

Hydrogen gas is formed during the charging operation and is explosive! Only charge batteries in a well-ventilated area with the lid open. Avoid any open flame or electrical sparks. Pulling out the charger plug with the timer on will cause an arc and must be avoided.



## SAFETY INSTRUCTIONS

THE FOLLOWING STATEMENTS ARE USED THROUGHOUT THIS MANUAL AS INDICATED IN THEIR DESCRIPTIONS:

 **DANGER**

To warn of immediate hazards which will result in severe personal injury or death.

 **WARNING**

To warn of hazards or unsafe practices which could result in severe personal injury or death.

 **CAUTION**

To warn of hazards or unsafe practices which could result in minor personal injury.

**ATTENTION**

To warn of unsafe practices which could result in extensive equipment damage.

**NOTE**

To give important information or to warn of unsafe practices which could result in equipment damage.

 **WARNING**

THE FOLLOWING INFORMATION SIGNALS POTENTIALLY DANGEROUS CONDITIONS TO THE OPERATOR OR EQUIPMENT. READ THIS MANUAL CAREFULLY. KNOW WHEN THESE CONDITIONS CAN EXIST. THEN, TAKE NECESSARY STEPS TO TRAIN MACHINE OPERATING PERSONNEL. FOR THE SAFE OPERATION OF THIS MACHINE, READ AND UNDERSTAND ALL WARNINGS, CAUTIONS AND NOTES.

 **WARNING**

Machines can ignite flammable materials and vapors. Do not use with or near flammables such as gasoline, grain dust, solvents, and thinners.

 **WARNING**

Heavy machinery. Improper use can cause personal injury.

 **WARNING**

Operate only when lids, doors, and access panels are securely closed.

 **WARNING**

Use care when reversing machine in confined area.

 **WARNING**

When servicing the machine, disconnect the batteries first to prevent possible injury.

 **WARNING**

When working on the machine, empty hopper, remove batteries, clear area of people and obstructions, use additional people and proper procedures when lifting the machine.

 **WARNING**

Always empty the hopper and disconnect the battery before doing maintenance.

 **WARNING**

You must have training in the operation of this machine before using it.  
**READ THE INSTRUCTION BOOK.**

 **WARNING**

Do not operate this machine unless it is completely assembled.

 **WARNING**

Do not use this machine as a step or furniture.

## SAFETY INSTRUCTIONS

---

 **WARNING**

Stop and leave this machine on a level surface. When you stop the machine, put the power switch in the "OFF" position and engage the Wheel Lock.

 **WARNING**

To prevent injury and damage to the machine, do not lift the machine or move it to an edge of a stair or loading dock.

 **WARNING**

Lead acid batteries generate gases, which can cause an explosion. Keep sparks and flames away from batteries. **NO SMOKING.** Charge batteries only in areas with good ventilation.

 **WARNING**

Always wear eye protection and protective clothing when working near batteries. Remove all jewelry. Do not put tools or other metal objects across the battery terminals or across the tops of batteries.

 **WARNING**

Authorized personnel must do maintenance and repairs only. Tighten all fasteners. Maintain adjustments according to the specifications given in the service manual for the machine. Keep the electrical parts of the machine dry. For storage, keep the machine in a building.

 **WARNING**

Make sure all labels, decals, warnings, cautions and instructions are fastened to the machine. Purchase new labels and decals from American-Lincoln.

 **WARNING**

The operator must exhibit extreme caution when negotiating, turning, and traveling across grades or ramps. Start, stop, change direction, travel and brake smoothly. Slow down when turning.

 **WARNING**

Avoid uneven surfaces and loose materials. Watch for obstructions, especially overhead.

 **WARNING**

Operate only from the designated operator's position. Stay inside the body of the machine. Keep hands and feet on the designated controls. Always operate in well-lighted areas.

 **WARNING**

Do not carry passengers on the machine. Set the Wheel Lock when leaving the machine. Chock (block) the wheels if the machine is parked on a grade (ramp), or is being prepared for maintenance.

 **WARNING**

Never leave the operator's compartment when the engine is running.

 **WARNING**

Report damage or faulty operation immediately. Do not operate the machine until repairs have been completed. Authorized personnel must do maintenance and repairs only.

 **WARNING**

To maintain the stability of this machine in normal operation, the overhead guard, counterweights, rear bumper guard, or any similar equipment installed by the manufacturer, as original equipment should never be removed. If it becomes necessary to remove such equipment for repair or maintenance, this equipment must be reinstalled before the machine is placed back into operation.

## SAFETY INSTRUCTIONS

---



### WARNING

Electrical hazard. Shocks can cause serious personal injury. Unplug the battery before cleaning or servicing. To avoid possible injury or property damage, read the Operator's Manual before servicing the machine. Authorized personnel must do maintenance and repairs.



### WARNING

Disconnecting the battery connector with the key switch in the "I" position will cause sparks that could ignite explosive hydrogen gas generated by the batteries. To prevent serious injury or possible property damage, turn Key Switch to "O" position before disconnecting the battery cable from the machine for charging or service.

**FOR SAFETY, OBSERVE THE FOLLOWING WARNINGS. FAILURE TO COMPLY MAY CREATE A SERIOUS RISK OF INJURY TO YOU AND OTHERS. THIS MACHINE SHOULD NOT BE USED IN HAZARDOUS LOCATIONS INCLUDING AREAS OF VOLATILE DUST OR VAPOR CONCENTRATIONS.**

**Operators must be trained and qualified to operate this machine. They must also understand the operator's manual before starting.**

**Use caution when mounting or dismounting the machine particularly on wet slippery surfaces.** Do not dump the hopper over an open pit or dock. Do not dump the hopper when positioned on a grade (ramp). The machine must be level (horizontal).

## OPERATION OF CONTROLS AND GAUGES

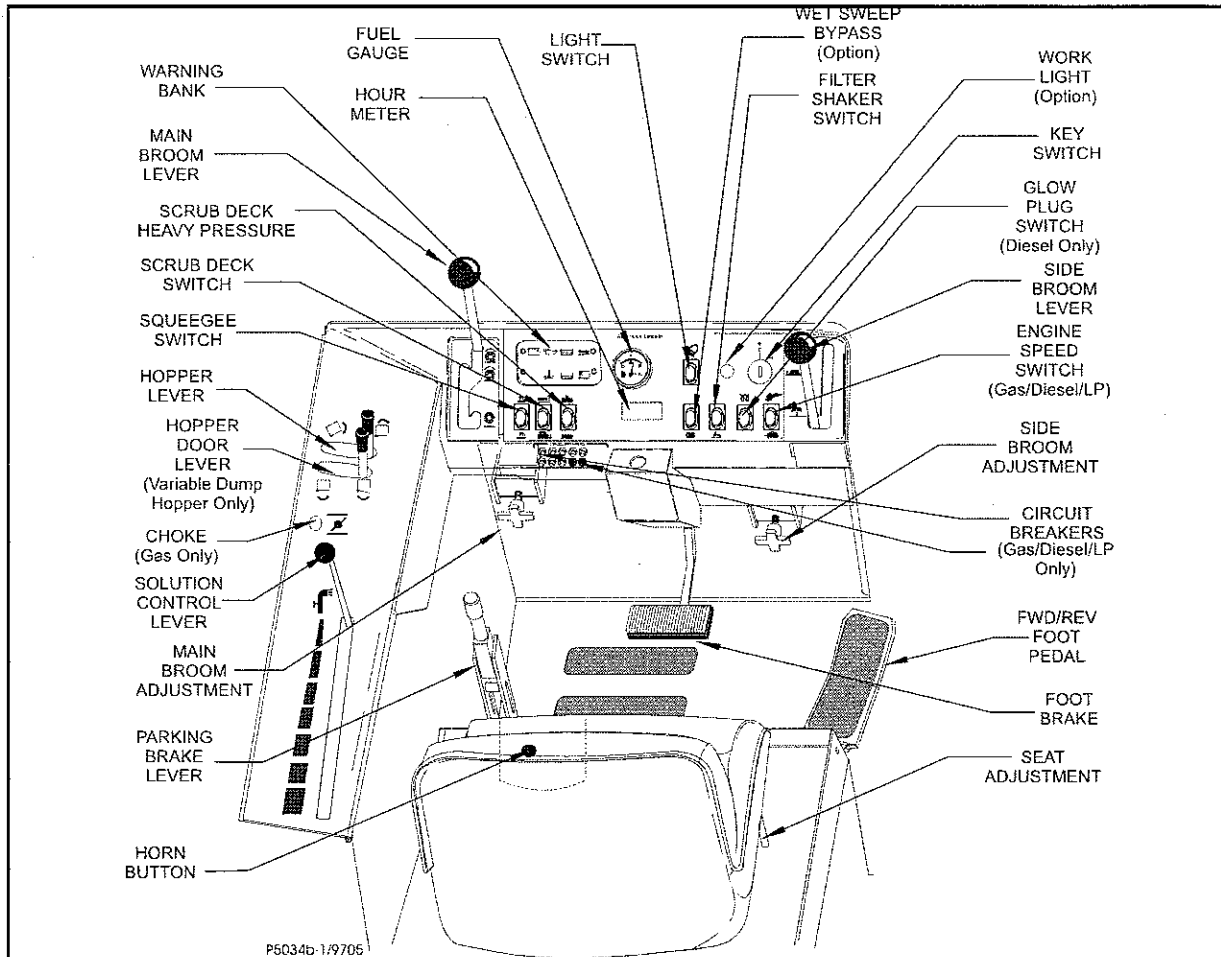

P5034b-1

FIGURE 2

### LIGHT SWITCH (See Figure 2)

The light switch is located above the horn button to the right of the steering wheel. It will work various light options that are available for this machine, such as:

- \* HEAD LIGHTS
- \* TAIL LIGHTS
- \* INSTRUMENT LIGHTS

### HORN BUTTON (See Figure 2)

The horn button is located on the left side of the floor plate. Push the button with your foot to sound the horn. The horn button is always active.

### CHOKE (Gas Only) (See Figure 2)

The choke control is located on the left side console and is used to aid in starting the engine. The choke governs the mixture of air and fuel during the combustion cycle of the engine operation. The choke should be pulled during the start of the engine and the gradually pushed in after the engine warms up.

- To turn on the choke for "Cold" starting, pull out the knob marked choke.
- To turn off the choke once the engine has been started, gradually push the knob control in.

## OPERATION OF CONTROLS AND GAUGES

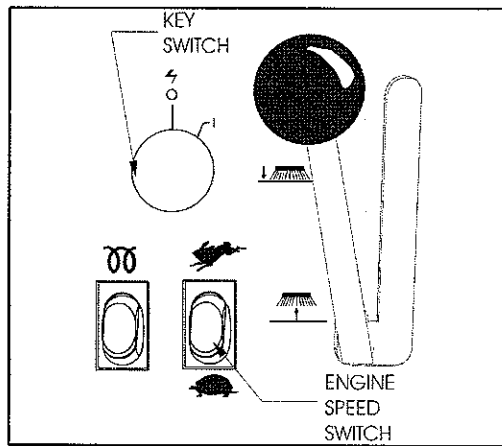

C1631A FIGURE 3

### KEY SWITCH (See Figure 3)

The keyed ignition switch is located on the instrument panel to the left of the side broom lever. The key switch is a two-position switch that controls power to the machine systems and accessories.

The "OFF" position (O position) will shut off the engine.

The IGN/ON position (I position) provides power to all machine systems and accessories.

The "START" position (one position clockwise of I position) is momentary and provides power to the starter motor.

### NOTE

To re-engage, the starter key must be returned to the "OFF" position.

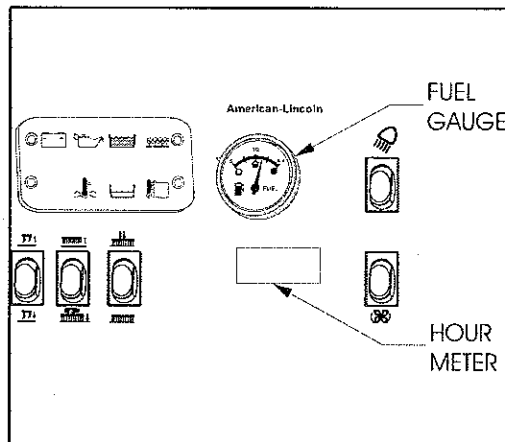

C1633 FIGURE 4

### ENGINE SPEED SWITCH (See Figure 3)

A two-position switch controls the engine, which is located on the instrument panel to the left of the side broom lever. The switch position determines the governed operating speed of the engine.

Place the speed switch in the "IDLE" position to start the machine.

Place the speed switch in the "FAST" position for transport and when normal sweeping action is desired.

### HOUR METER (See Figure 4)

The hour meter is located on the instrument panel above the engine speed switch. The meter is activated when the key switch is placed in the ignition position. The meter indicates the actual "run" time of the machine. The meter can be used to determine when maintenance should be done on the machine.

### FUEL GAUGE (See Figure 4)

The fuel gauge is located on the instrument panel to the right of the main broom lever and indicates the level of fuel in the tank. The key switch powers the fuel gauge. The key switch must be in the "ON" position for the fuel gauge to work. The fuel gauge is not included on machines that use Liquid Propane fuel.

### SEAT POSITION ADJUSTMENT (See Figure 5)

The seat position adjustment lever is located on the right side of the seat base. The lever is spring loaded to the "LOCK" position.

To adjust the seat, push "FORWARD" on the lever and move the seat to the desired position. Then release the lever to "LOCK" the seat into place.

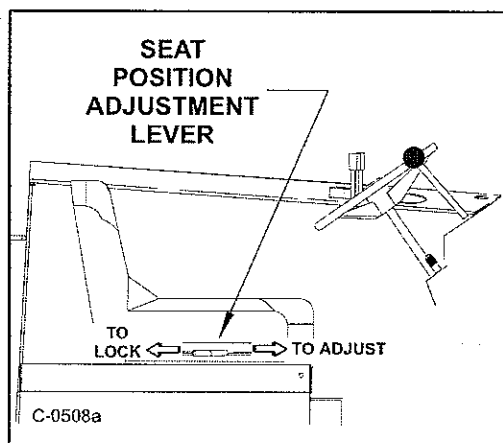

C0508A-2 FIGURE 5

## OPERATION OF CONTROLS AND GAUGES

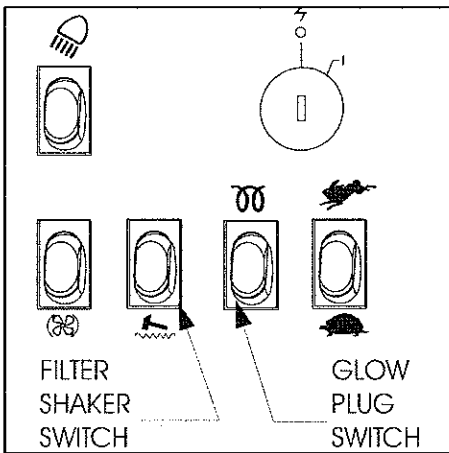

C1640-2 FIGURE 6

### FILTER SHAKER SWITCH (Variable Dump Machines Only) (See Figure 6)

The filter shaker switch is located on the instrument panel below the ignition switch. This is a momentary switch that will activate the filter shaker motors for 20 to 30 seconds to clear the dust control filter. The Impeller fan will stop when the filter shaker has been activated. The filter shaker will only operate with the hopper in the "DOWN" position.

Use the filter shaker to clear the filter when the dust control light comes on (warning bank) and just before dumping the hopper.

### GLOW PLUG SWITCH (Diesel) (See Figure 6)

Under no circumstances should any other unauthorized starting aids be used at the same time as Glow Plugs. The Glow Plug Switch is located to the right of the steering column on the front face of the instrument console. Use the following procedure to operate.

1. Before operating the starter motor, press the "GLOW PLUG" switch for 20 to 30 seconds.
2. With the "GLOW PLUG" switch still depressed, engage the starter motor until the engine starts.
3. Continue to press the "GLOW PLUG" switch for a few seconds after the engine has started until even running has been obtained.
4. If the engine does not start, disengage the starter motor, but keep the "GLOW PLUG" switch depressed for a further 10 to 15 seconds, when a further attempt should be made to start the engine, keeping the Glow Plugs energized while starting and for a few seconds after the engine has fired until it is running smoothly.

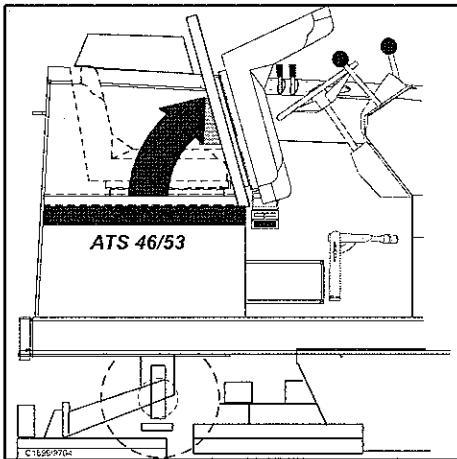

C1699 FIGURE 7

### SEAT COMPARTMENT PROP LATCH (See Figure 7)

The seat compartment latch is located under the seat compartment cover and is used to hold the cover open.

To hold the seat compartment cover open, lift the cover and rotate the latch.

### HOPPER SAFETY ARM (See Figure 8)

The hopper safety arm is located near the right front wheel well. The safety arm will prevent the hopper from dropping unexpectedly during service/maintenance.

#### TO ENGAGE THE SAFETY ARM:

1. Empty hopper
2. Set the parking brake.
3. Raise the hopper.
4. Lift safety arm to engage the slot on the hopper frame.
5. When work has been completed, replace the safety arm to the stowed position.

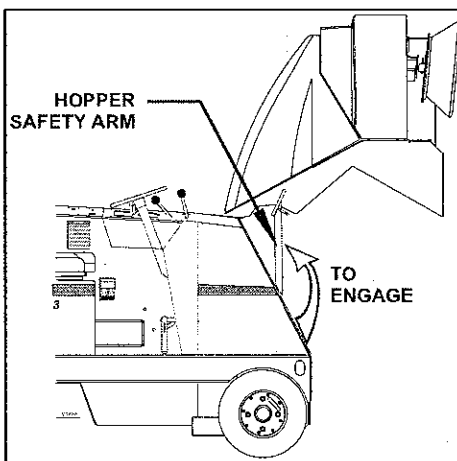

C1700 FIGURE 8

## OPERATION OF CONTROLS AND GAUGES

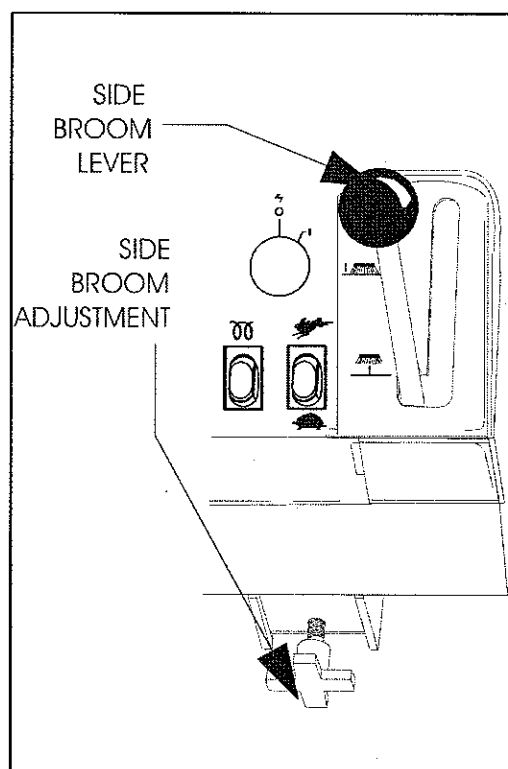

C1641 FIGURE 9

### SIDE BROOM LEVER (See Figure 9)

The Side Broom Lever is located to the right of the instrument console. The handle pulled back and turned to the left, will raise the side broom and lock it into position.

To raise the side broom pull the lever back into the "UP" position.

To lower the side broom, move the lever out of the "UP" position and move it forward to the "DOWN" position.

#### NOTE

IF THE MAIN BROOM IS ENGAGED, THE SIDE BROOM WILL AUTOMATICALLY ENGAGE WHEN LOWERED.

### SIDE BROOM ADJUSTMENT (See figure 9)

The side broom lever has an adjustment for changing the sweep height to compensate for broom wear. The side broom adjustment is located under the right side of the instrument panel.

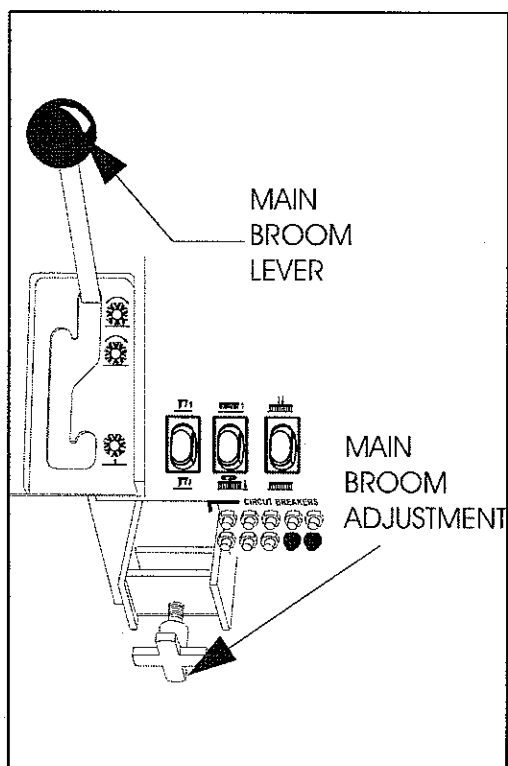

C1642-1 FIGURE 10

### MAIN BROOM LEVER (See figure 10)

The main broom lever is located on the left side of the instrument panel. The main broom lever has three positions and controls the main broom sweep height.

To lower the main broom, grasp the lever and move it to the left out of the "UP" position, and place it in the "SWEEP" or "FLOAT" position.

The "SWEEP" position is used for normal sweeping and should be used under most sweeping conditions (approximately 2" broom pattern).

The "FLOAT" position is used for sweeping very uneven surfaces only. Using the float position will cause premature wear on the main broom if used under normal operating conditions for extended periods of time (approximately 4" broom pattern).

#### NOTE

The Main Broom will automatically engage when lowered to the sweep position or the float position. The hopper must be completely closed.

### MAIN BROOM ADJUSTMENT (See Figure 10)

The main broom lever has an adjustment for changing the sweep height to compensate for broom wear. The main broom adjustment is located under the left side of the instrument panel.

## OPERATION OF CONTROLS AND GAUGES

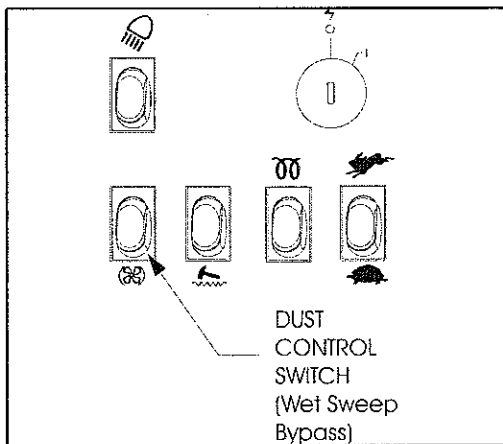

C1640-1 FIGURE 11

### DUST CONTROL SWITCH (Wet Sweep Bypass Option - Option for All Machines) (See Figure 11)

The Dust Control Switch is a two position switch located on the instrument panel next to the filter shaker switch. The switch controls the vacuum fan in the dust control system. (Optional on I.C. Engine: Standard on Batt. Power)

To turn on the dust control system for "NORMAL" sweeping, press on the top portion of the switch. To turn off the dust control system for sweeping in wet conditions, press the lower portion of the switch. This will prevent the filter from being damaged by water pickup while sweeping.

### SCRUB DECK SWITCH (See Figure 12)

The brushes switch is located on the console to the left of the steering wheel in the "SCRUBBING" section. This switch in the position marked "LOWER" will lower the scrub brush deck and activate the three scrub brushes. The heavy pressure switch cannot be activated unless this switch is in the "LOWER" position. This switch in the "RAISE" position will stop the brushes from rotating and raise the scrub brush deck

#### NOTE

Lowering the scrub deck will not start the brushes rotating the foot pedal must be moved to engage the scrub brushes. If the machine stops moving for 2 seconds or more the brushes will automatically stop rotating until the machine starts moving again.

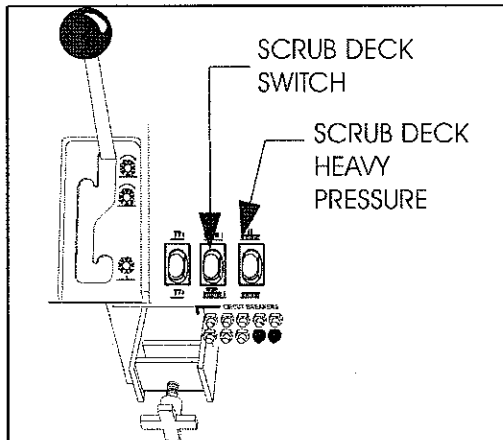

C1642A FIGURE 12

### SCRUB DECK HEAVY PRESSURE SWITCH

(See Figure 12) (I.C. Machines Only)

The scrub deck heavy pressure switch is located on the console to the left of the steering wheel in the "SCRUBBING" section. This switch applies additional downward pressure to the scrub brushes. This switch has two positions down "NORMAL" and up "HEAVY". This switch cannot be activated unless the scrub deck switch is in the "LOWER" position, the switch will light when it can be activated.

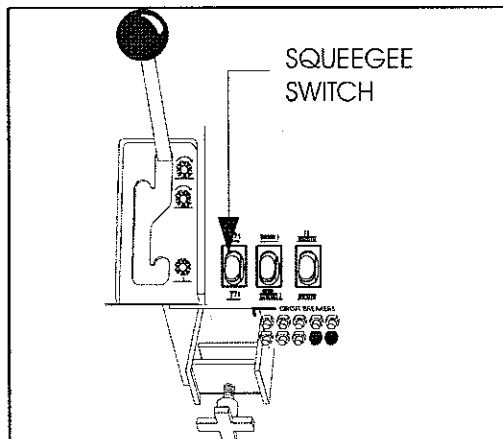

C1642B FIGURE 13

### SQUEEGEE SWITCH (See Figure 13)

The squeegee blade switch is located on the console to the left of the steering wheel in the "SCRUBBING" section. This switch in the position marked "LOWER" will lower the squeegee and activate the squeegee vacuum. This switch in the "RAISE" position will stop the squeegee vacuum and raise the squeegee. A switch activated by the forward-reverse foot pedal will automatically raise the squeegee if it is in the lowered position and the machine is in reverse.

The switch has a center position to raise the squeegee with the vacuum in to allow vacuuming the water left on the squeegee recovery hose. This prevents water from dripping on the floor with the squeegee "UP."



## OPERATION OF CONTROLS AND GAUGES

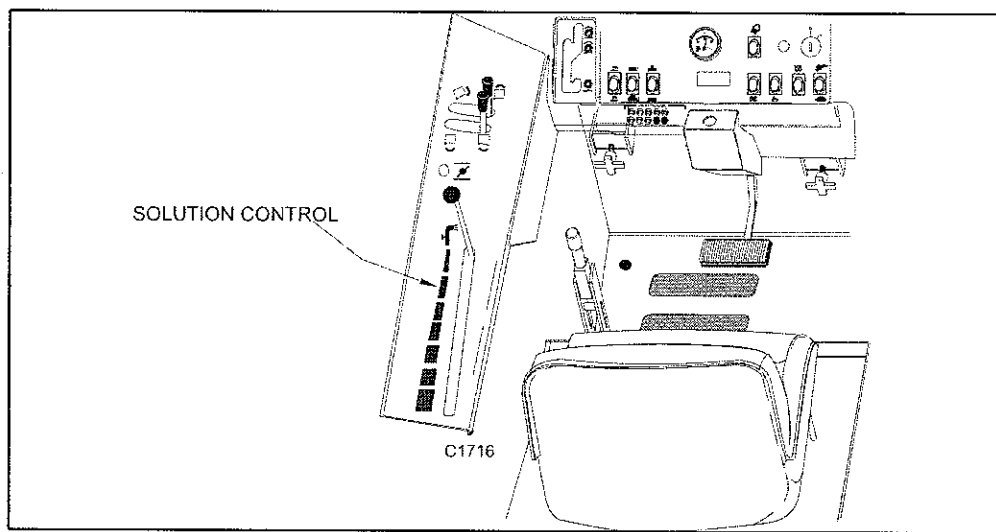

C1716

FIGURE 14

### **SOLUTION CONTROL (See Figure 14)**

To apply solution to the scrub brushes, pull the solution control lever back until the desired setting is reached. The solution rate is continuously variable from off to approximately 1-3/4 GPM at low and 3 GPM at high. To stop application of solution push forward on the lever until it stops at the "off" position. The solution warning light will illuminate when the solution tank is low, marking the end of the scrubbing cycle.

### **NOTE**

For best results, discontinue application of solution 10 feet before stopping or making a 90° or 180° turn.

### **NON-RECYCLING OR STANDARD SCRUBBING SYSTEM**

1. Make sure the solution control lever is in the "off" (FORWARD) position.
2. Open the solution tank cover (Vacuum Assembly)
3. Fill the tank with 70 gallons of water and the correct mixture of American-Lincoln #100 Industrial Cleaner for the job on hand.
4. Close the solution tank cover (Vacuum Assembly).

### **RECYCLING OR ESP & AUTOFIL SYSTEM**

1. Make sure the solution control lever is in the "off" position.
2. Connect hose to autofill coupling.
3. Turn the key switch to the "ACC" position.
4. Turn on the water hose valve.
5. Fill the detergent tank with American-Lincoln #100 Industrial Cleaner.
6. The system will fill the solution and recovery tank to proper levels and shut off the water flow.

### **TO DISCONNECT WATER HOSE**

1. Leave ignition switch in the "on" position
2. Turn the water off at the source
3. "Tip" the float switch on the solution tank to depressurize the water hose before disconnecting

### **WARNING**

To prevent oversudsing and machine damage, use only AMERICAN-LINCOLN Industrial Cleaner Solution #100. DO NOT put gasoline, combustible or flammable material in the solution, detergent, or recovery tanks.

## OPERATION OF CONTROLS AND GAUGES

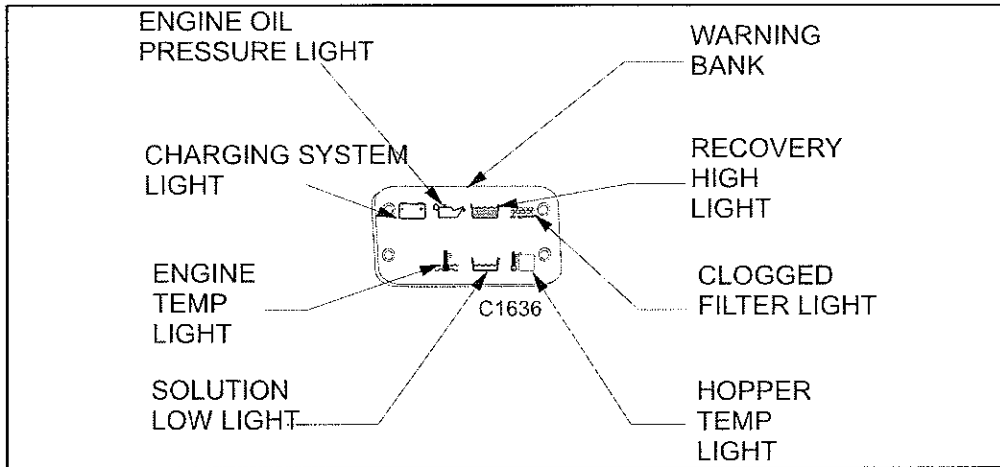

C1636

FIGURE 15

### WARNING BANK (See Figure 15)

The Warning Bank is located on the instrument panel and provides the operator with seven fault/status indicators for engine and sweeper systems. The operator should monitor the indicators while sweeping. It is very important that the operator be familiar with the meaning of each indicator.

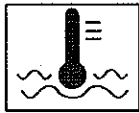

#### ENGINE TEMPERATURE LIGHT

The engine temperature light illuminates to indicate an engine cooling system fault. When this occurs the operator must turn off the sweeper immediately and have the cooling system serviced by a qualified service technician.

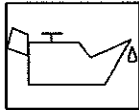

#### ENGINE OIL PRESSURE LIGHT

When the oil pressure drops below approximately 5 PSI an automatic protection circuit shuts down the engine and illuminates the light to indicate low engine oil pressure. When this occurs, have the machine serviced by a qualified service technician.

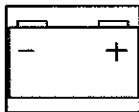

#### CHARGING SYSTEM LIGHT

The charging system light illuminates to indicate a charging system fault. When this occurs the machine's charging system is not working properly, have the machine serviced by a qualified service technician.

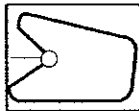

#### CLOGGED FILTER LIGHT (Option)

The clogged filter light illuminates to indicate that the dust control filter is clogged. When this occurs, stop the machine and use the filter shaker to clear the dirt and debris from the filter. After using the filter shaker, continue sweeping.

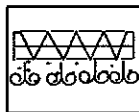

#### HOPPER TEMPERATURE LIGHT (Option)

When the temperature of the air moving through the hopper dust control system exceeds 140° F, an automatic protection feature shuts down the dust control fan and illuminates the hopper temperature light. When this occurs, shut down the machine and carefully investigate for a possible fire in the hopper, then manually reset the switch.

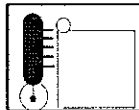

#### SOLUTION LOW LIGHT

The solution low warning light will illuminate when the solution tank is empty, indicating the end of the scrubbing cycle.

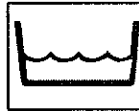

#### RECOVERY HIGH LIGHT

The recovery high warning light will illuminate approximately 5 minutes before the recovery tank is full, giving ample time to complete the scrubbing cycle, before the mechanical float shuts off the vacuum to the recovery tank.

## OPERATION OF CONTROLS AND GAUGES

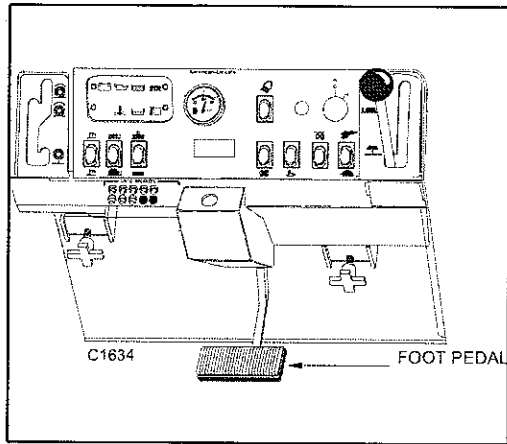

C1634-1 FIGURE 16

### FOOT BRAKE (See Figure 16)

The foot brake pedal is located on the floor of the operator's compartment to the left of the directional control pedal. To stop, use the front wheel brakes, by putting pressure on the brake pedal.

### PARKING BRAKE (See Figure 17)

The parking brake lever is located on the operator's compartment left side panel near the floor. When engaged, the parking brake "locks" the foot pedal in the down position.

To engage the parking brake, place lever in the upright position.

To disengage the parking brake, move the lever forward.

To adjust the parking brake "grab", turn the knob on the top of the lever. To increase the "grab", turn the knob in a clockwise direction:

To decrease the "grab", turn the knob in a counterclockwise direction.

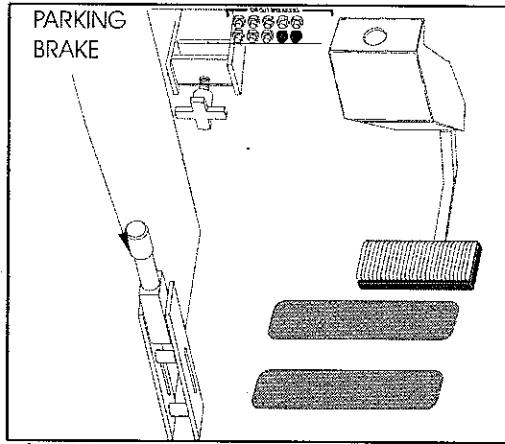

C1635 FIGURE 17

### FWD/REV FOOT PEDAL (See Figure 18)

The foot pedal is located on the floor of the operator's compartment to the right of the brake pedal. The foot pedal provides control of direction/speed. The pedal height is adjustable to provide for operator comfort.

To adjust the foot pedal height for operator comfort;

1. Remove the hairpin cotter from the adjustment pin.
2. Remove the adjustment pin from the foot pedal assembly.
3. Align the holes in the lower bracket with one of the four adjustment holes on the foot pedal to set the foot pedal height.
4. With the holes aligned at the desired height, insert the adjustment pin.
5. Re-install the hairpin cotter.

**TO GO FORWARD:** Place pressure on the upper portion of the pedal. Speed increases when additional pressure is placed on the pedal.

**TO GO BACKWARD:** Place pressure on the lower portion of the pedal. Speed decreases when additional pressure is placed on the pedal.

**TO STOP:** Allow the pedal to return to the centered position.

To increase braking action while moving in reverse gently put pressure on the upper portion of the pedal.

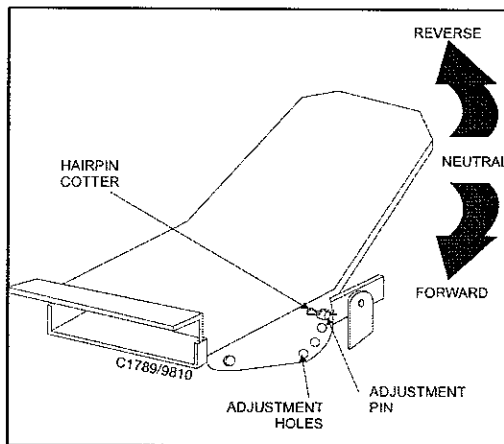

C1789 FIGURE 18

## OPERATION OF CONTROLS AND GAUGES

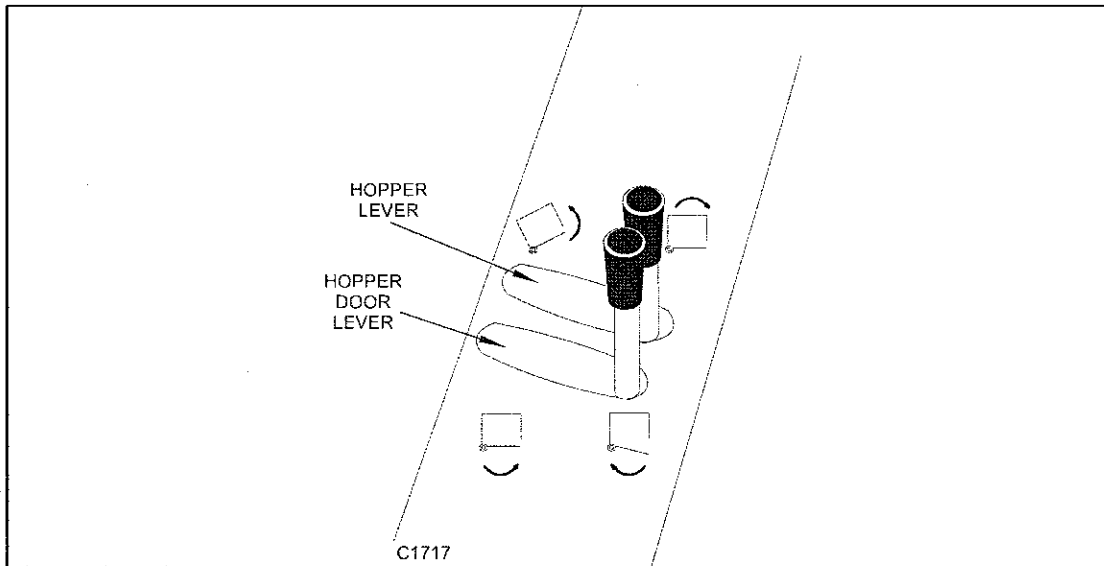

C1717

FIGURE 19

### NOTE

The main broom, side broom, dust control and filter shaker turn off automatically when the hopper is dumping and/or the dump door is in a closed position. SEE HOPPER LIFT and HOPPER DUMP DOOR.

### HOPPER LIFT LEVER - (See Figure 19)

The hopper lift lever is located to the left of the steering wheel on the left side of the driver's compartment. This lever, which is marked "HOPPER", raises and lowers the debris hopper to ease unloading.

### WARNING

The hopper may drop unexpectedly and cause injury, always engage the safety arm before working under the hopper.

### HOPPER DUMP DOOR LEVER - (See Figure 19)

The hopper dump door lever is located to the left of the steering wheel on the left of the driver compartment. This lever opens and closes the hopper door. This lever is located below the hopper lift door and is marked "DUMP DOOR".

### NOTE

A switch triggered by the hopper and dump door's position control the sweeping functions, main broom, side broom, dust control, and filter shaker. The hopper must be down and the dump door open to allow these functions to work.

## OPERATION OF CONTROLS AND GAUGES

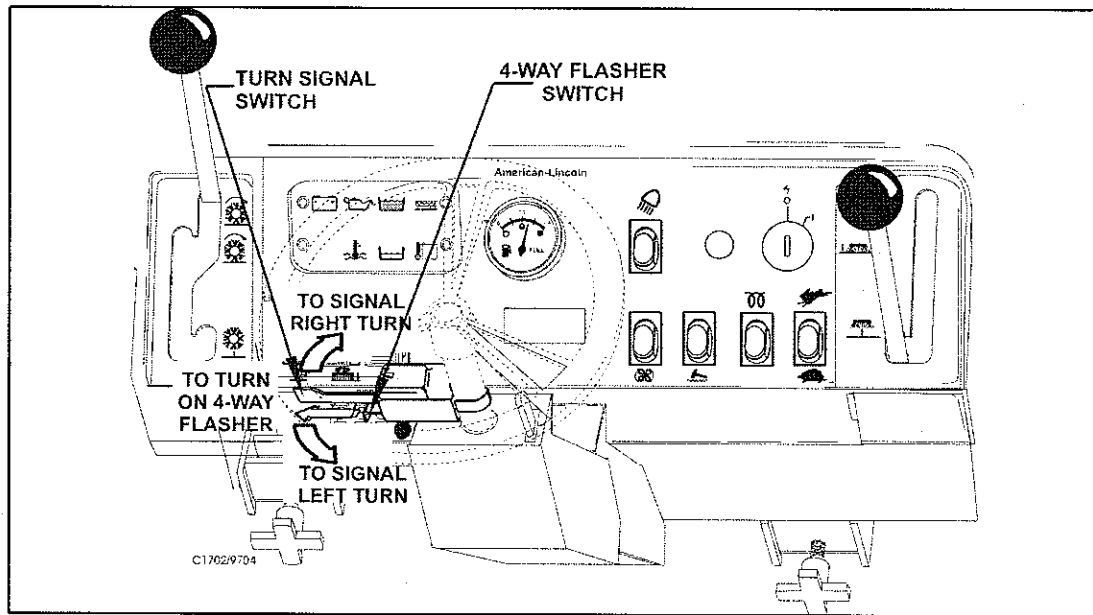

C1702

FIGURE 20

### **TURN SIGNAL - 4-Way (Option) (See Figure 20)**

The turn signal option is located on the steering column and works as automotive turn signals work, forward on the lever for right and back on the lever for left. The 4-way flasher will activate when the turn signal lever is pulled out.

### **THROTTLE (See Figure 20)**

The throttle control is located to the left of the driver compartment. The engine must be operating at full governed speed of 2050 "no load" RPM (broom control off and machine sitting still), to maintain optimum machine travel speed, hopper loading and dust control. Before turning off the key and stopping the engine, move lever to idle speed.

### **BACK-UP ALARM SWITCH (Option) (See Figure 20)**

The back-up alarm is operated by a switch that is located under the lower section of the accelerator and directional control pedal. The alarm makes a loud audible noise when the machine is being driven in reverse.

### **BATTERY CONDITION METER (Battery Machine)**

The battery condition meter is located on the right side of the instrument panel. The condition meter indicates the level of charge in the batteries. The batteries are sufficiently charged when the needle stays in the green area on the gauge while the machine is being operated.

Charge batteries when the needle drops into the red zone while operating the machine. Do not operate the machine if the needle stays in the red area.

## OPERATION OF CONTROLS AND GAUGES

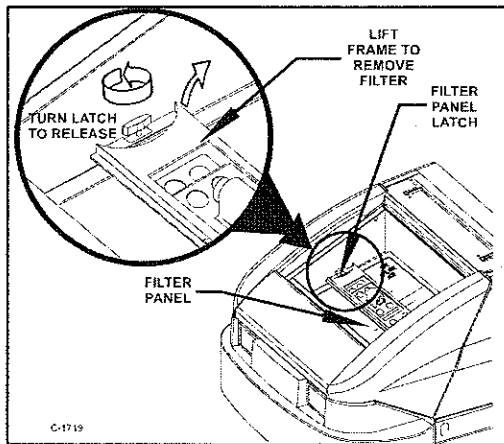

C1719 FIGURE 21

### FILTER PANEL LATCH (See Figure 21)

The filter panel is located in the hopper filter compartment and will need to be removed periodically for cleaning or replacement. Removal of the filter panel requires no tools. The hopper cover must be opened to gain access to the filter compartment. The panel filter is held in place by a hinged frame and latch.

To remove the panel filter, turn the knob counterclockwise and lift the hinged frame.

The panel filter can now be lifted out and cleaned or replaced (see Filter Cleaning instructions in this manual).

To install the replacement panel filter, lower the frame and turn the knob clockwise to lock the filter in place.

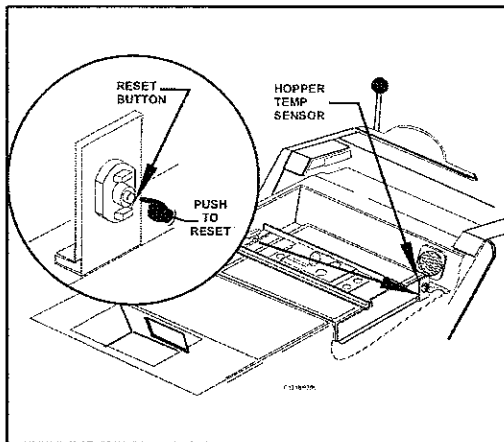

C1718 FIGURE 22

### HOPPER TEMP SENSOR (Option) (See Figure 22)

The temp sensor switch monitors the hopper air temperature near the vac fan. When the temperature of the air moving through the hopper exceeds 140°F, the switch is tripped. It turns off the dust control fan and illuminates the hopper temp light on the warning bank.

The hopper temp sensor can be reset thermal switch which is located in the hopper filter compartment near the vacuum fan intake.

When the hopper temp light illuminates, carefully investigate for a possible fire in the hopper.

To reset the temp sensor, press the reset button.

### ENGINE COMPARTMENT LATCH (See Figure 23)

The engine cover encloses the entire engine, radiator and hydraulic reservoir assembly. The cover can be lifted to allow easy access to the engine and hydraulics for service and inspection.

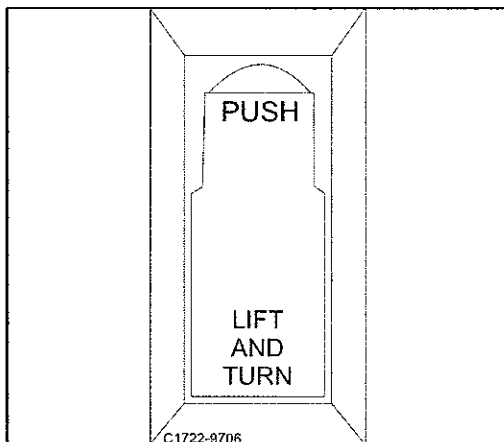

C1722 FIGURE 23

### WARNING

Operate Only When Lids, Doors, And Access Panels Are Securely Closed.

To open the cover, lift the cover latch lever up and turn the latch ¼ turn. Lift the cover open.

### NOTE

The overhead guard option has a safety latch for storing open cover.

After closing the engine cover, check it to be certain the latch has fully engaged and is latched.

### NOTE

Side covers can be removed for service.

## OPERATION OF CONTROLS AND GAUGES

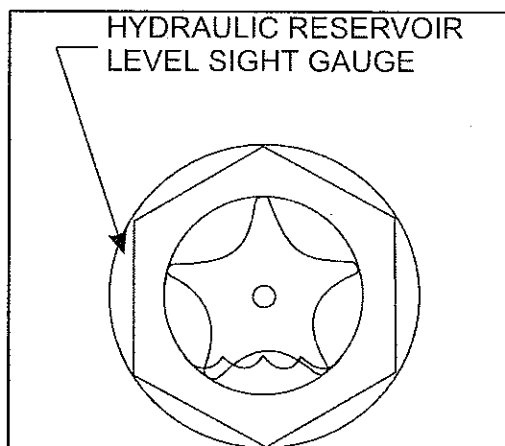

C1730 FIGURE 24

### HYDRAULIC RESERVOIR LEVEL SIGHT GAUGE

(See Figure 24)

The sight gauge is located on the inside of the hydraulic reservoir in the engine compartment. The sight gauge is used to indicate the level of fluid in the reservoir. The fluid level must be visible in the sight gauge when the hopper is in the down position.

### MAIN BROOM COMPARTMENT DOORS (See Figure 25)

The main broom compartment doors are located behind the front tires on both sides of the machine. The doors provide access to the main broom for service or inspection.



#### WARNING

Operate Only When Lids, Doors, And Access Panels Are Securely Closed.

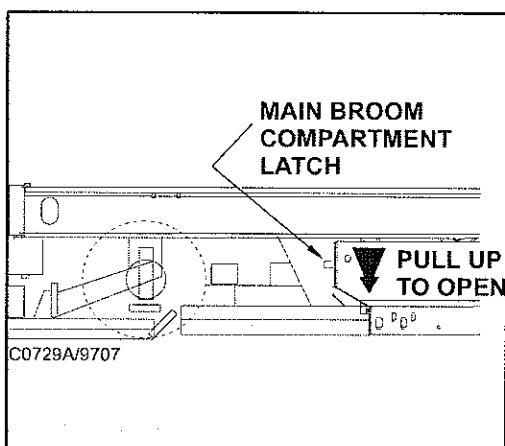

C0729A FIGURE 25

Open the right side door to remove or replace the main broom. The right side door is an integral part of the main broom drive system and must be closed for operation.

Open the left side broom door for inspection. Check the drive hub for banding and shrink-wrap which have a tendency to get tangled in the broom driver.

To open the main broom door, reach inside the hole in the door and lift up on the latch handle.

The door latch will automatically engage when the door is closed.

#### NOTE

Side squeegees mount on doors and the scrub deck must be lowered to slide the doors and squeegees into place.

#### NOTE

For proper function of side squeegees, side squeegees must be positioned so the lift strap is above the scrub deck lift brackets. Damage to the side squeegees could occur if not in the correct position.

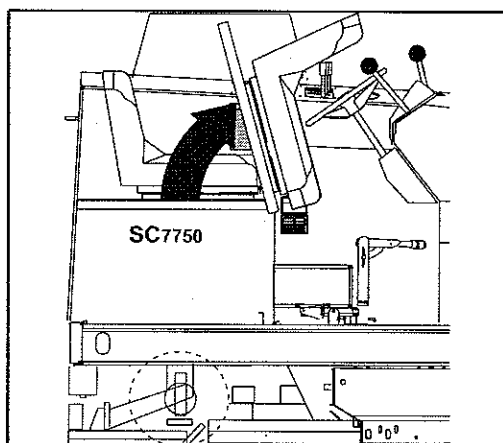

C0731AA FIGURE 26

### SEAT COMPARTMENT COVER (See Figure 26)

The seat compartment cover opens to allow easy access to various components that will need to be inspected or serviced periodically. The cover opens forward and has a safety latch to hold the cover in the open position.

On battery powered machines, the compartment below the seat contains motor and pump and hydraulic reservoir. On Gas/Diesel/LP powered machines, the seat compartment contains the fuel tank.

## OPERATION OF CONTROLS AND GAUGES

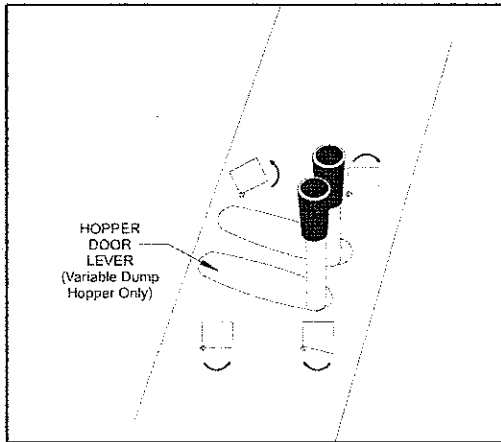

C1717A FIGURE 27

### HOPPER DOOR LEVER (See Figure 27)

The hopper door lever is located on the operator's compartment and is used to close and open the hopper dump door. The lever is a two position hydraulic valve that is spring loaded to the center position which "HOLDS" the hopper door in position.

To open the hopper dump door for sweeping or dumping, push the lever to the "OPEN" direction.

To close the hopper dump door for dumping or transporting, push the lever fully back in the "CLOSE" direction, and hold for 3 seconds or until you hear the door close.

#### NOTE (Gas)

The dump door will automatically open when the main broom is engaged and the hopper is lowered.

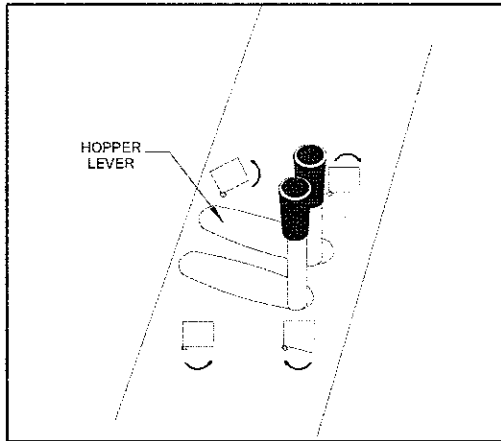

C1717B FIGURE 28

### HOPPER LIFT LEVER (See Figure 28)

The hopper lift lever is located on the operator's compartment console. The lever is a two position hydraulic valve that controls the operation of the hopper lift system. The lever is spring loaded to the center position which stops hopper movement and "HOLDS" the hopper at the present position.

To raise the hopper for dumping, move the lever to the "RAISE" position and hold until the hopper reaches the desired height, then release.

#### WARNING

The hopper may drop unexpectedly and cause injury, always engage the safety arm before working under the hopper.

To lower the hopper after dumping, move the lever to the "LOWER" position until the hopper is fully lowered and seated in the machine, then release.

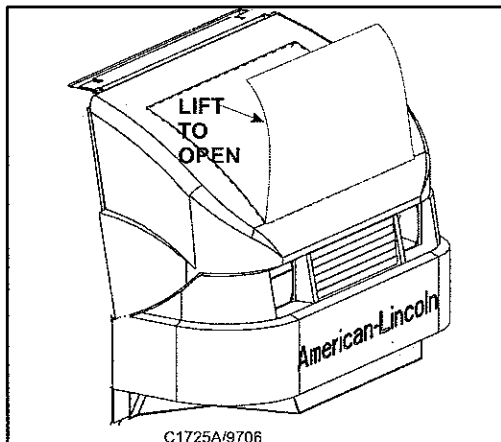

C1725A FIGURE 29

### HOPPER FILTER COMPARTMENT COVER (See Figure 29)

The hopper filter compartment cover is located on the top of the hopper and opens forward for access to the filter compartment for service and inspection of the dust control filter and optional hopper temp sensor.

Inspect the cover gaskets daily. Replace any cover gaskets that show signs of deterioration. Failure to maintain the gaskets in serviceable condition will degrade dust control at the floor and will result in less than optimal sweeping performance.



## ESP SYSTEM OPERATING INSTRUCTIONS

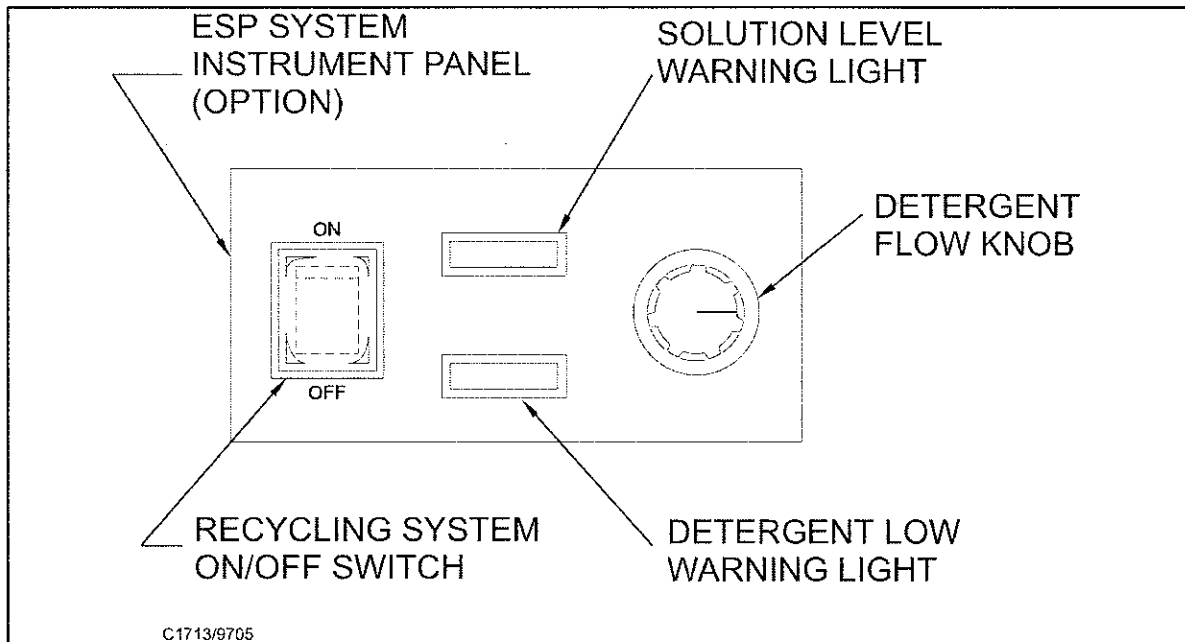

C1713

FIGURE 30

### THE ESP RECYCLING CONTROL PANEL (See Figure 30)

#### THE ESP RECYCLING SYSTEM ON/OFF SWITCH

This switch turns the ESP recycling system on and off.

#### NOTE

The solution control lever must be on "FULL" for ESP operation.

#### SOLUTION LEVEL WARNING LIGHT

The solution level warning light will go out when the solution tank is empty. Some solution will remain in the recovery tank at the end.

#### DETERGENT LOW WARNING LIGHT

The detergent light will illuminate when the detergent tank is low, warning the operator to add detergent.

#### DETERGENT FLOW KNOB

This rotary knob controls the detergent flow into the scrubbing solution. The operator may choose from any detergent setting, for light to heavy cleaning applications. The detergent light will illuminate when the detergent tank is low, warning the operator to add detergent.

#### HOPPER SAFETY LOCK ARM (See Figure 31)



#### WARNING

When the hopper is raised the safety arm must be engaged before ANY work is done under the hopper.

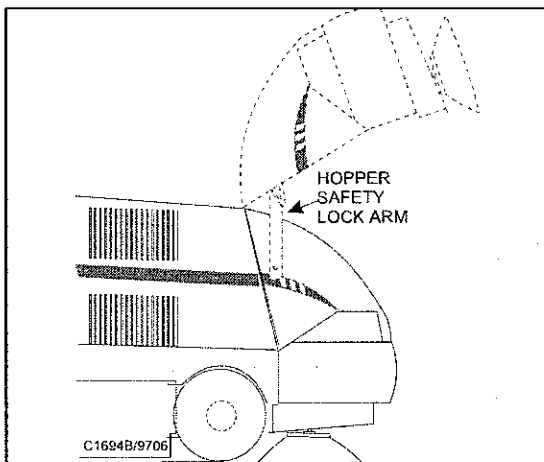

C1694B

FIGURE 31

The hopper safety lock arm is located under the hopper assembly. After the work is complete the safety arm must be disengaged.

## ESP SYSTEM OPERATING INSTRUCTIONS

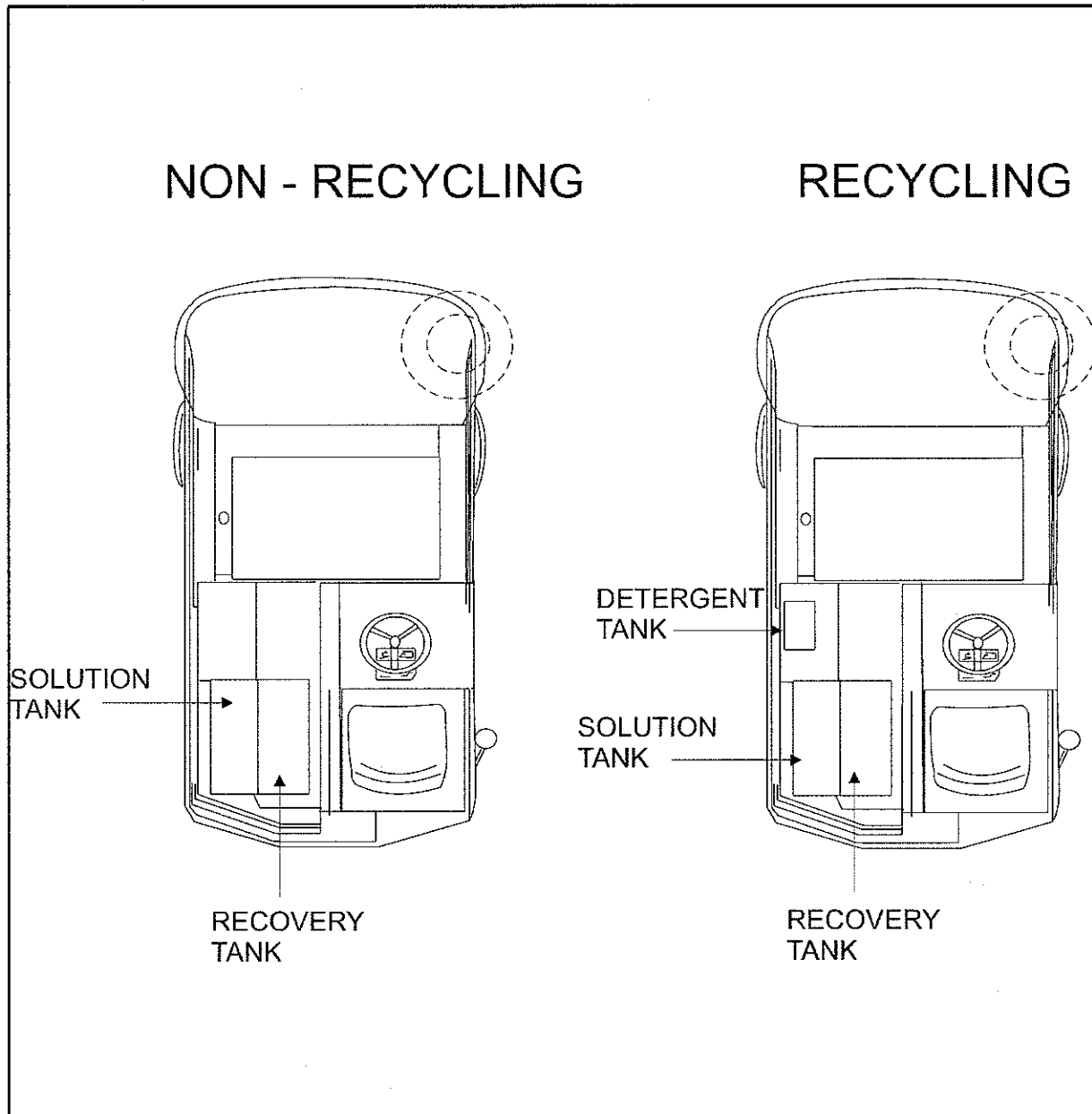

C1728

FIGURE 32

### THE SCRUBBING SYSTEM - HOW IT WORKS

There are two scrubbing systems available for the SC7750 machine, the non-recycling or standard scrubbing system and the recycling or ESP scrubbing system.

### THE NON-RECYCLING OR STANDARD SCRUBBING SYSTEM - HOW IT WORKS

During the scrubbing process, detergent solution water from the solution tank is fed to the solution line. There it is fed to the floor where three disc scrubbing brushes work to dislodge soil.

After scrubbing, the dirty solution is vacuumed from the floor and discharged into the containment chamber in the forward portion of the recovery tank, where a system of baffles helps to clarify the solution.

Sensors in each tank will indicate, by lights on the control panel, when the water in the solution tank is too low or when the water in the recovery tank is too high.

## ESP SYSTEM OPERATING INSTRUCTIONS

### THE RECOVERY OR ESP AND AUTOFIL SYSTEM - HOW IT WORKS

During the scrubbing process, filtered water from the solution tank is fed to the solution line, where it combines with detergent from the metering pump. This mixture is then fed to the floor where three disc scrubbing brushes work to dislodge soil.

After scrubbing, the dirty solution is vacuumed from the floor and discharged into the recovery tank. At intervals, a float switch activates the recycling pump, which sends filtered solution from the recovery tank to the solution tank. Detergent is added continuously to solution water from the flow valve.

The autofil system distributes water from the supply hose into the recovery and solution tanks. Then a solenoid valve is closed when the proper level in the solution tank is reached.

#### NOTE

Both tanks must be drained and cleaned before filling.  
Tuck solution tank drain hose behind bumper during operation

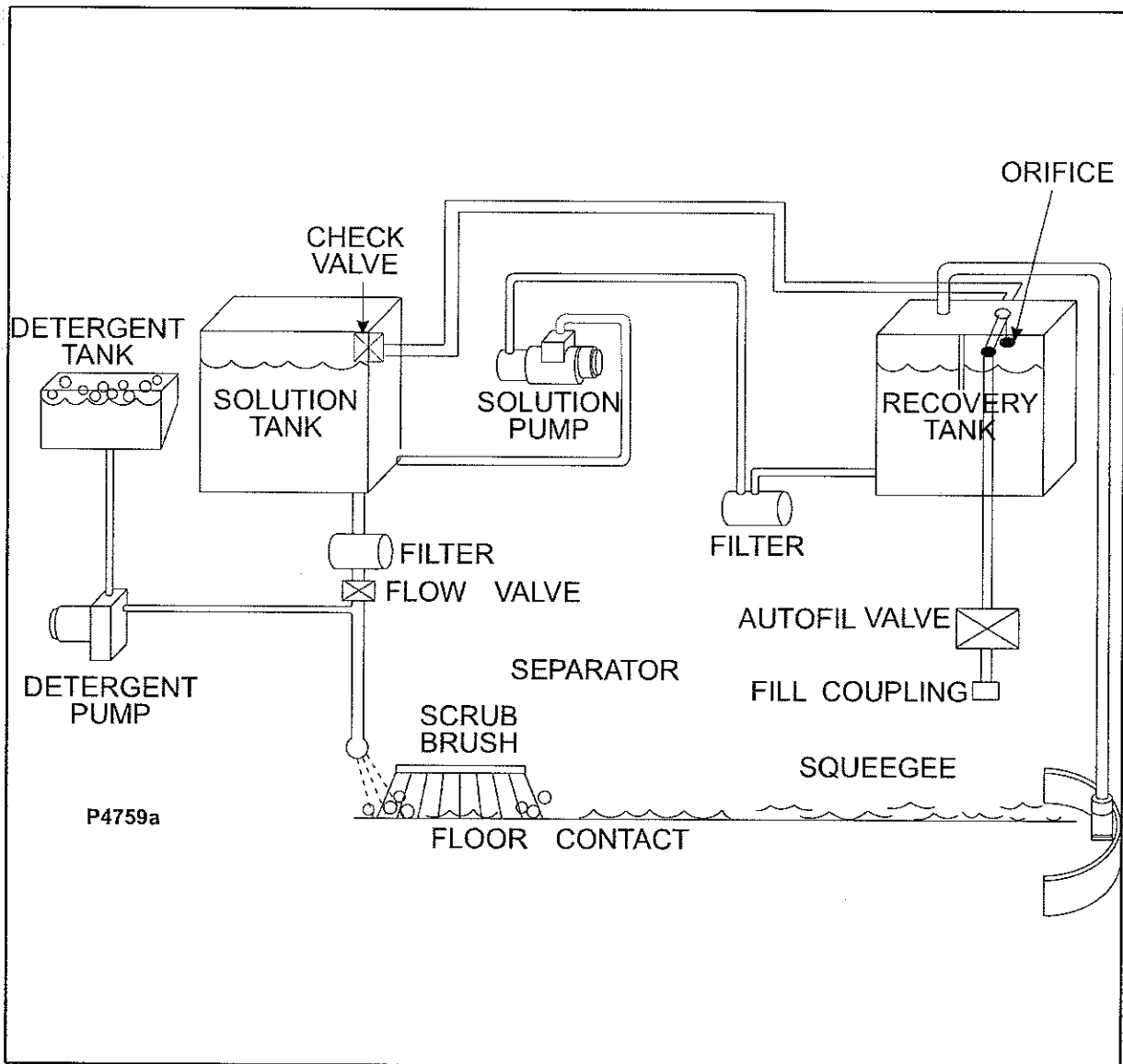

P4759A

FIGURE 33

## OPERATING INSTRUCTIONS

### THE VARIABLE DUMP SWEEPING AND DUST CONTROL SYSTEMS-HOW THEY WORK

Variable Dump SC7750 machines are equipped with a sweeping and dust control system. (See Figure 34)

#### DUST CONTROL

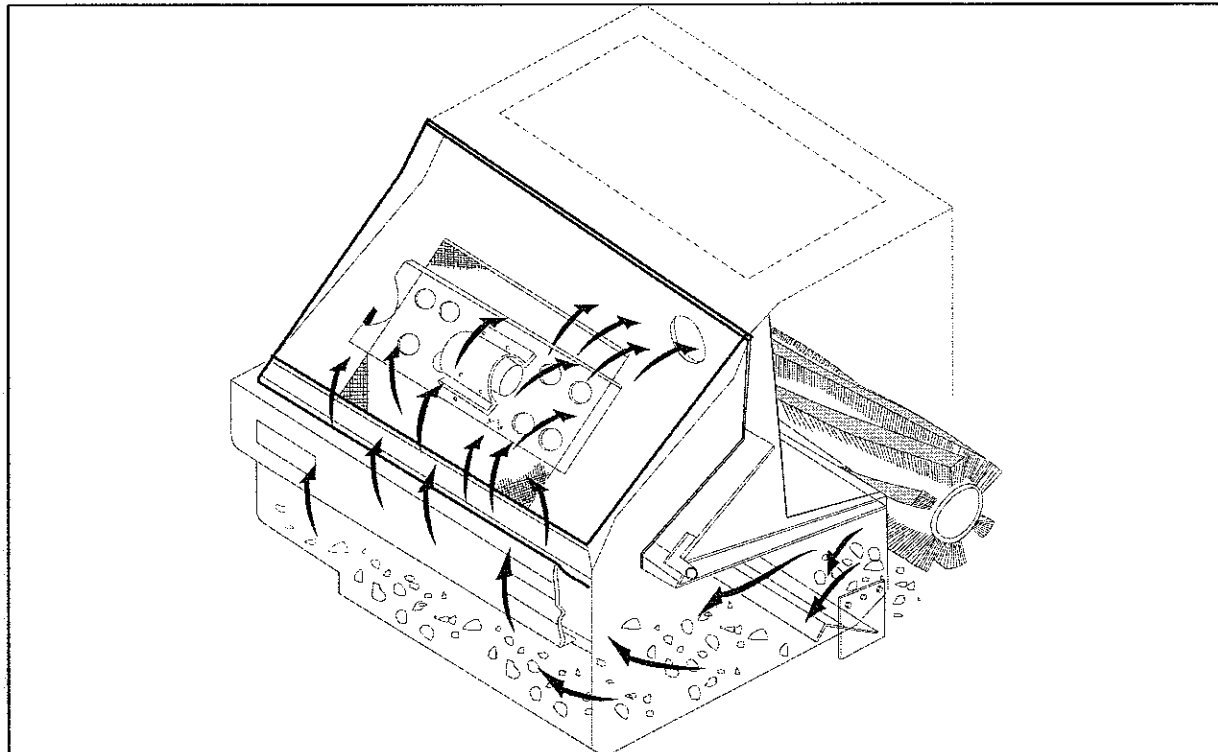

C1731

FIGURE 34

#### BEFORE STARTING THE ENGINE

1. Set parking brake.
2. Make sure all controls are in the "OFF" position.
3. Be sure the directional control pedal is in neutral.
4. Ensure the batteries have been fully charged and serviced (see battery service instructions).

#### NOTE

Before starting the engine, perform the pre-start checklist.

#### PRE-START CHECKLIST

1. Clean engine air filter element.
- 2.\* Check engine oil level.
- 3.\* Check radiator coolant level.
4. Check hydraulic fluid level.
- 5.\* Check fuel level.
6. Check all systems for leaks.
7. Check brakes and controls for proper operation.
8. Check broom patterns.
9. Check to ensure that all covers, panels and access doors are securely closed.

\*Applies to Gas/Diesel/LP powered machines only

-Applies to Battery powered machines only

## OPERATING INSTRUCTIONS

### NOTE

To prevent possible fire, never fill fuel tank while the engine is running. Always be sure gasoline container and machine are grounded before dispensing gas. This can be done by permanently attaching an insulated wire with a battery clip on the end to the gasoline container.



### WARNING

When the machine has been stored in below freezing temperatures, run the engine at not over ½ throttle with the machine standing still for 5-10 minutes to warm the engine and hydraulic oil.

### STARTING BATTERY MACHINES

Starting the battery powered models is accomplished by turning the key switch to the "I" (on) position. It is important to note that the batteries should be fully charged and serviced prior to using the machine.

### STARTING GAS ENGINES

Use the choke in extremely cold temperatures, (under 32°F or 0°C).

1. Pull choke if needed.
2. Set the engine speed control to idle setting.
3. Turn key to "START" position until engine starts, then release. (Key switch will return to the "I" position.)
4. Push in the choke after engine starts running (if used).

### STARTING PROPANE ENGINES

Perform these checks in addition to the Pre-Start checklist

1. Check connections for leaks.
2. Open the LP storage tank valve.
3. Check the regulator. Momentarily press fuel primer on regulator cover to bleed air out of system.
4. Set the engine speed control to the "IDLE" (low) speed setting.
5. Turn key to "START" until engine starts, then release. (Key switch will return to the "I" position.)

### STARTING DIESEL ENGINES

When starting the diesel engine, it should be noted that under no circumstances should ether or any other starting fluids be used in conjunction with the glow plugs. Do not use the glow plugs for more than 20 seconds at a time or damage to the plugs may result. The key switch must be placed in the "I" position before using the glow plug switch.

1. Perform the pre-start checks.
2. Turn the key switch to the "I" position and place the engine speed switch on the high speed position.
3. Push and hold the glow plugs switch for 5-10 seconds. Under cold starting conditions, the glow plug switch may be held longer, but do not hold the switch for more than 20 seconds to prevent damage to the glow plugs.
4. Turn the key switch to the start position and hold until the engine starts. If the engine does not start immediately, release the key switch after 15 seconds to prevent damage to the starter.
5. Release the glow plug switch when the engine starts.

### EMPTYING THE DEBRIS HOPPER (Variable Dump)

1. Place the engine speed switch in the "Fast" position.
2. Engage the parking brake.
3. Move the hopper dump door lever to the "CLOSE" position until the door is closed.
4. Move the hopper lift lever to the "RAISE" position until the hopper reaches the desired height.
5. Disengage the parking brake.
6. Drive forward slowly with hopper raised to clear the refuse container before opening hopper dump door.
7. Engage the parking brake.
8. Push the hopper dump door lever forward to the "OPEN" position. This will allow debris in the hopper to fall out into the refuse container.
9. Move the hopper dump door lever to the "CLOSE" position until the door is closed.
10. Disengage the parking brake.
11. Drive in reverse slowly to clear the refuse container.
12. Engage the parking brake.
13. Move the hopper lift lever forward to the "LOWER" position and hold until the hopper is closed.
14. Move the hopper dump door lever to the "OPEN" position until the dump door opens.



### WARNING

Do not turn off the engine with the hopper in the lifted position.

## OPERATING INSTRUCTIONS

---

### NOTE

After stopping the engine, perform these post-operation checks.

### POST-OPERATION CHECKLIST

1. Clean the debris hopper.
2. Check sweeping brooms for wear or damage.
3. Check all flaps for wear, damage and adjustment.
4. Fill the fuel tank.
5. Check all systems for leaks.
6. Close the LP storage tank valve (LP powered machines only).
7. Charge and service motive power batteries (see battery charging instructions).
8. Check squeegees for damage.



### WARNING

The gasoline tank fill cap is located behind the driver's seat. Do not mistake the hydraulic reservoir for the gasoline tank.

### BATTERY CHARGING INSTRUCTIONS (Battery Machine)

Charge the batteries at the end of each day or when the battery condition meter indicates low battery voltage. The batteries need to be charged when the needle stays in the "red" zone while the machine is being operated. When charging the batteries, only use the quick disconnect provided to ensure correct polarity. Follow the instructions below.

Check the liquid level in the batteries at least once a week and add water when low. Use only distilled water. Fill the batteries after charging them to prevent electrolyte from spilling over onto the tops of the batteries during the charging process.



### WARNING

The use of an extension cord with the charger should be avoided. Risk of fire and electrical shock is possible if the wrong type or size extension cord is used. Locate all cords so they cannot be stepped on, tripped over, or otherwise subjected to damage or stress.

### GASOLINE POWERED MACHINES

Machines to be stored over 30 days should be completely drained of fuel to prevent gum deposits from forming on essential carburetor parts, fuel filter, and tank.

The use of a fuel additive, such as STA-BIL, or an equivalent, will minimize the formation of fuel gum deposits during storage. Such an additive may be added to the gasoline in the fuel tank of the engine.

The following procedures should be used to prepare the machine for storage:

1. Remove all fuel from the tank. Run the engine until it stops from lack of fuel.
2. While the engine is still warm, drain oil from the crankcase. Refill with fresh oil.
3. Remove spark plug, pour approximately ½ ounce (15 grams) of engine oil into the cylinder and crank slowly to distribute oil. Replace spark plug.
4. Store in a clean and dry area.

### BATTERY POWERED MACHINES

When batteries are not in use, they will discharge much sooner in cooler temperatures than in warm temperatures. Recharging and storing is more efficient at room temperature.

Do not discharge the batteries excessively (do not go below 80%). Excessive discharge can cause polarity reversal of the individual cells in the battery. This will lead to complete failure of the batteries.

Use a hydrometer to monitor the specific gravity of the individual cells in the batteries. When checking the specific gravity of the batteries, you should not see a large difference between the individual cells. The batteries may need to be replaced if the battery shows a significant difference of specific gravity between the cells.

## HELPFUL HINTS FOR CLEANING OPERATION

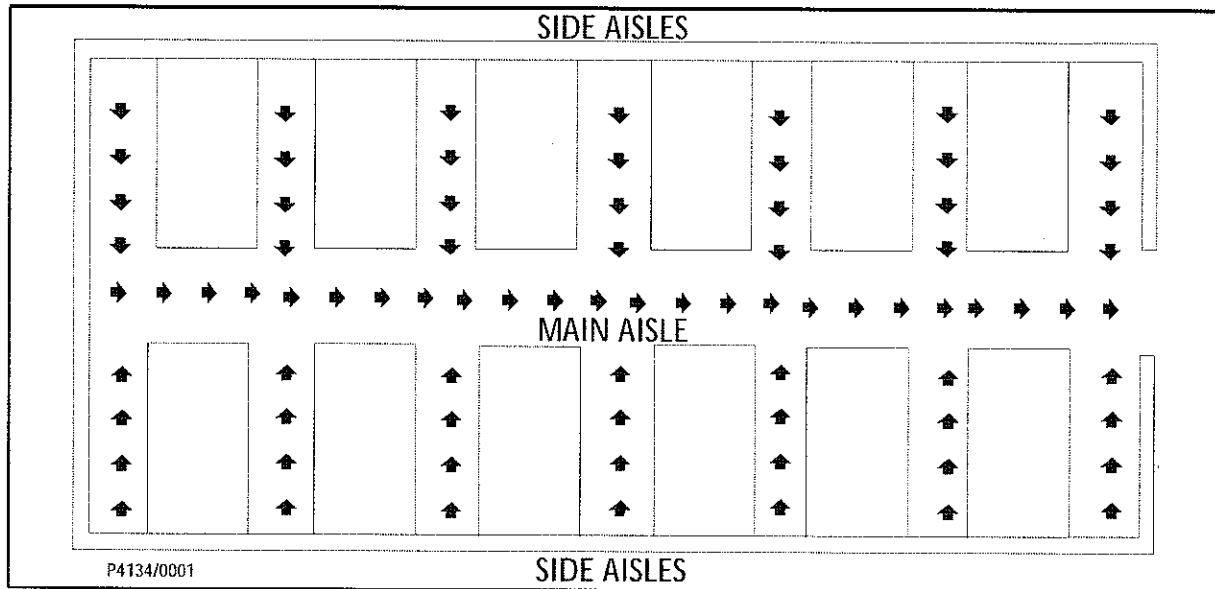

P4134

FIGURE 35

### WARNING

Do not turn the steering wheel sharply when the machine is in motion. The machine is very responsive to movement of the steering wheel. Do not make sudden turns. Scrub in straight paths. Do not bump posts. Do not scrape the sides of the machine.

When the machine is in motion, do not push the directional/speed control pedal all the way forward. This is the same as starting in "High" and will put a strain on the motor and drive system.

1. Plan your sweeping and scrubbing in advance. Try to arrange long runs with minimum stopping and starting. Sweep debris from narrow aisles out into main aisles ahead of time. Do an entire floor or section at one time.
2. Pick up oversize debris before sweeping.
3. Allow a few inches of overlap of sweep and scrub paths. This will eliminate leaving dirty patches.
4. Do not turn steering wheel too sharply when the machine is in motion. The machine is very responsive to movement of the steering wheel, so avoid sudden turns.
5. Try to follow as straight a path as possible. Avoid bumping into posts or scraping the sides of the machine.
6. When placing the machine in motion, avoid slamming the directional control pedal all the way forward quickly. This is equivalent to starting in "High" and puts needless strain on the engine and drive system.
7. Always allow the machine to warm up before operating in cold temperatures.
8. Periodically turn the sweeping broom end-over-end to prevent the bristles from "setting" in one direction.

### NOTE

Replace the sweeping broom when the bristles are worn to 3 inch (8cm) length. To order replacement brooms, see page 208. Replace disc brushes when bristles are reduced to ½ inch (1.3 cm) in length. To order replacement brushes, see page 208. Replace squeegee rubbers when all usable edges have become rounded with wear, impairing the wiping action. To order replacement squeegee rubbers, see page 196 or 197.

# SERVICE CHART

## SERVICE CHART

Check items for proper operation. If service is required, please contact an authorized American-Lincoln distributor. For best performance, replace worn parts with genuine American-Lincoln parts.

### BREAK-IN

During the initial break-in period of the engine, the crankcase oil and filter should be changed after 20 hours.

### EVERY 8 HOURS or DAILY operation check and clean/adjust if necessary:

1. Inspect panel filters for damage and clean them.
2. Check engine oil level.
3. Check hydraulic fluid level.
4. Check radiator core for blockage.
5. Check all flaps for wear or damage.
6. Check brooms for wear or damage, adjust as required.
7. Check panel filters (clean side) for leakage.
8. Check brake pedal and parking brake.
9. Check for LPG/DIESEL odor at connections.
10. Check water separator.
11. Check engine air cleaner.
12. Check hydraulic oil filter.
13. Check coolant level.
14. Check battery electrolyte level.
15. Check belt tension.
16. Check all fluid system components for leaks.

LP, DIESEL

### 50 HOUR (WEEKLY) MAINTENANCE CHECKLIST

17. Check solution tank (recycling or ESP system).
18. Check solution filter screen (recycling or ESP system).
19. Check recovery tank.
20. Check recovery tank screens and filters.
21. Inspect scrub brushes for wear or damage.
22. Inspect rear and side squeegees for wear or damage.
23. Check tension on all belts.
24. Check battery electrolyte level (unless maintenance free battery).
25. Check all hydraulic hoses for wear or cuts.
26. Rotate main brush (end over end).
27. Clean or replace panel filters.
28. Lubricate dump system and drive wheel pivot points.

Perform recommended engine maintenance (see engine manual if applicable).

### 100 HOUR MAINTENANCE CHECKLIST

29. Change crankcase oil.
30. Change engine oil filter.
31. Lubricate drive wheel, swivel wheel bearings, and steering rack guide (engine side above rear wheel).
32. Lubricate front wheel bearings.
33. Lubricate all moving joints.
34. Check brake shoes for wear and adjust accordingly.
35. Lubricate all 3 DANHOUSER bushings with NAPA #765-1363 or equivalent anti-seize lubricant. The bushings are located on the steering, scrub deck lift, squeegee lift, variable dump hopper door.
36. Check fuel hose for leaks or deterioration.
37. Check radiator hoses and clamps.
38. Clean or replace engine air filter element as necessary.

Perform recommended engine maintenance (see engine manual if applicable).

### 250 HOUR MAINTENANCE CHECKLIST

39. Lubricate squeegee casters.
40. Clean solution tank and filter screen.
41. Replace engine air filter element.
42. Flush radiator coolant system.
43. Remove spark plugs - clean or replace.
44. Check distributor and points - service or replace.
45. Clean and lubricate governor & choke linkage.
46. Replace fuel filter.
47. Replace hydraulic filter element.

LP, GAS  
LP, GAS  
LP, GAS

Perform recommended engine maintenance (see engine manual if applicable).

### 400 HOUR MAINTENANCE CHECKLIST

48. Clean hydraulic reservoir.
49. Clean hydraulic intake strainer.
50. Change hydraulic fluid.



**SERVICE CHART**

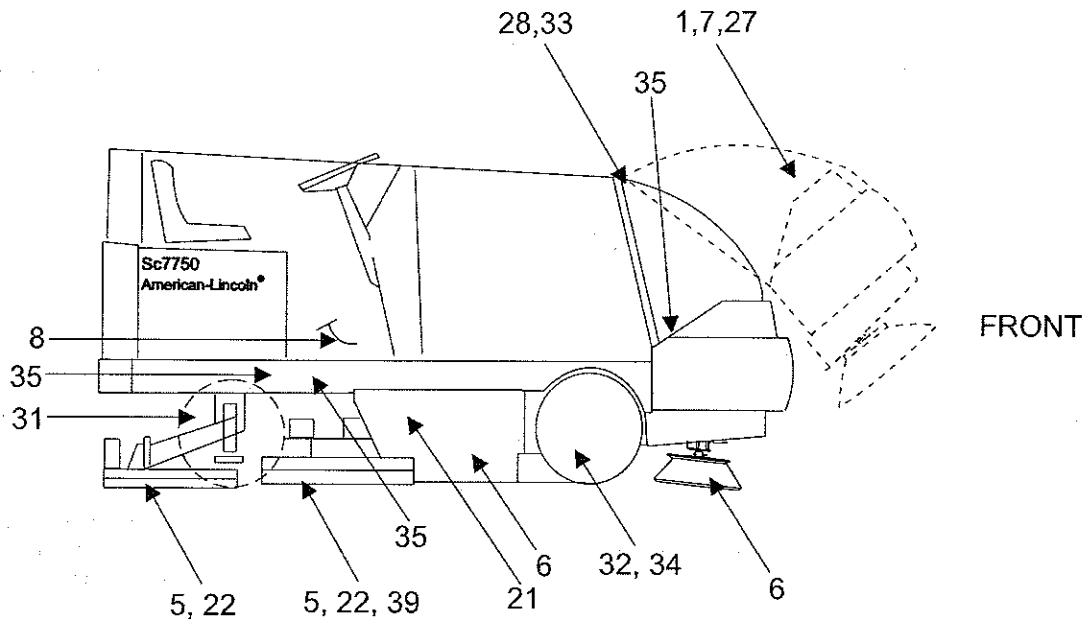
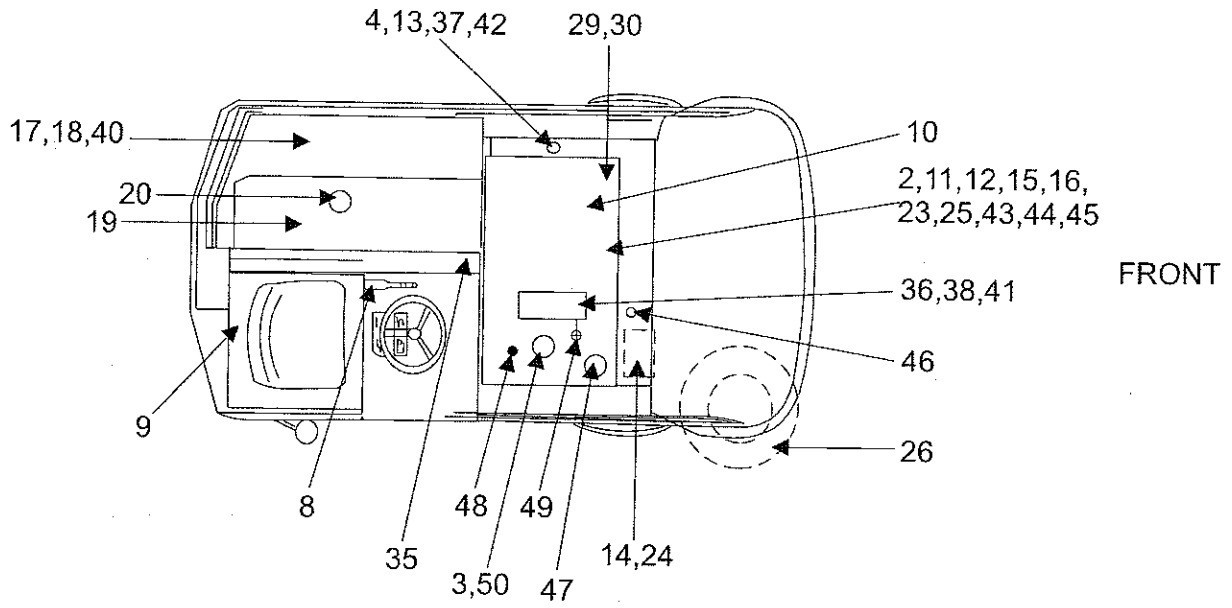

C1729/9710

## SERVICE PRECAUTIONS

---

### SERVICE PRECAUTIONS

For safety, read and follow the service precautions below. Know the hazards associated with the equipment you are working on to prevent personal injury or damage to equipment.

For service assistance, consult your nearest American-Lincoln Dealer. For best performance, replace worn parts with genuine American-Lincoln parts.

Refer all Maintenance and Service Requirements to Qualified Maintenance Personnel.



#### WARNING

Do not attempt to Service this Machine until you have read and understand all Safety Warnings associated with the equipment you are working on.



#### WARNING

Authorized personnel must do electrical repairs only. Consult your American-Lincoln Authorized Service Person to do service procedures. Use only genuine American-Lincoln parts.



#### WARNING

Unexpected movement could cause injury. Always park on a level surface, turn key off, and engage parking brake before working on the machine.



#### WARNING

Authorized personnel must do maintenance and repairs only. Always empty the hopper and disconnect the batteries before doing any maintenance. Keep all fasteners tight. Keep adjustments according to the specifications as shown in the Service Manual for this machine.



#### WARNING

Always wear eye protection and protective clothing when working near batteries. Do not put tools or other metal objects across the tops of the batteries. NO SMOKING.



#### WARNING

The hopper could fall and cause serious injury. Always engage the hopper safety arm before working under the hopper.



#### WARNING

Moving the fan and belt may cause injury. Stay clear of moving parts.



#### WARNING

Pinch points may cause injury. Stay clear of moving parts.



#### WARNING

To maintain the stability of this machine in normal operation, the overhead guard, or any similar equipment installed by the manufacturer as original equipment should not be removed. If it becomes necessary to remove such equipment for repair or maintenance, this equipment must be reinstalled before the machine is placed back in operation.



#### WARNING

To prevent injury or engine damage, do not remove the radiator cap under any conditions while the engine is running or when it is hot. To prevent burns from steam or scalding hot coolant being expelled from the radiator, use extreme care when removing the radiator cap. Wait until the engine has cooled.

### SWEEPING SYSTEM SERVICE

#### MAIN BROOM

To prevent the broom from "setting" in one direction and to provide the maximum life of the broom it is recommended that the broom be turned end over end periodically.

#### CHECKING THE MAIN BROOM SWEEP PATTERN

Check the main broom sweep pattern after changing the broom or when poor sweeping performance is encountered while sweeping.

1. While the machine is not moving, lower the main broom to the "SWEEP" position and let machine sweep in one spot for a short period of time.
2. Before moving the machine, raise main broom lever to the "UP" position and move the sweeper forward enough to see the pattern left by the main broom bristles on the floor.
3. Check the width of the pattern on the floor to determine if the main broom requires adjustment.

-A normal sweep pattern left on the floor will be between 1 and 2 inches wide.

-A pattern that is more than 2 inches wide indicates the broom linkage needs to be adjusted "UP."

-A pattern that is less than 1 inch wide indicates the broom linkage needs to be adjusted "DOWN."

#### ADJUSTING THE MAIN BROOM HEIGHT

When changing the sweep height adjustment it is recommended that the bolt be adjusted 1 turn at a time. After adjustment, recheck the sweep pattern to determine if further adjustment is necessary.

-Turn the adjustment knob counterclockwise to INCREASE the sweep pattern width.

-Turn the adjustment knob clockwise to DECREASE the sweep pattern width.

#### REPLACING THE MAIN BROOM

The Main Broom should be replaced when the bristles become worn to less than 2". The main broom is held in place by the right side broom door. This feature provides for easy removal and installation of the main broom without the need for special tools or equipment. Follow the instructions below for main broom removal & replacement.

1. Park sweeper on a smooth level surface, engage parking brake, turn key switch to "O", place the main broom lever in the "SWEEP" position.
2. Lift the door latch to open the right side broom door.
3. Swing the broom drive idler hub out to clear the main broom.
4. Remove the broom from the broom compartment.
5. Install the replacement broom. Pay special attention to the slots on the broom, it may be necessary to rotate the broom so the tabs on the drive hub align with the slots on the broom.
6. Swing the idler hub to engage the main broom and close the access door. Check the door latch for proper engagement when closed.
7. Check the Main Broom sweep pattern and adjust as necessary.

#### MAIN BROOM LEVEL ADJUSTMENT

The main broom level is factory set and should not need adjustment. If the level becomes out of adjustment and the broom bristle contact pattern is not an even 1" to 2" wide, the broom arm lift frame will need to be adjusted. The frame is supported by two plates located inside the broom doors. The carriage bolts that secure the plates to the frame will need to be loosened. The frame can then be leveled and the bolts re-tightened.

## SERVICE INSTRUCTIONS

### SIDE BROOM SERVICE

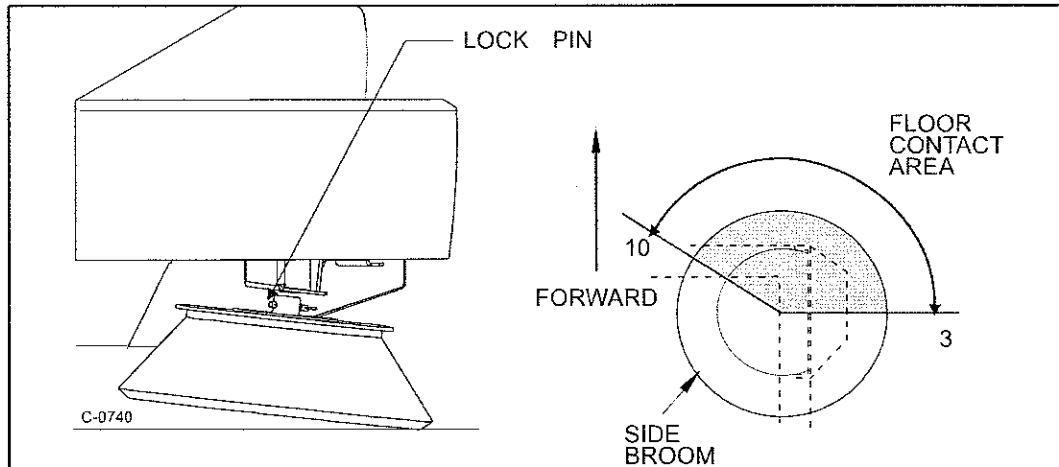

C0740

FIGURE 36

### SIDE BROOM

The Side Broom sweeping angle is not adjustable however the height of the side brooms can be adjusted to compensate for wear as the broom becomes worn from use. Always check and adjust the sweep pattern after changing the side broom.

### CHECKING THE SIDE BROOM SWEEP PATTERN ADJUSTING THE SIDE BROOM HEIGHT

Turn the side broom adjustment knob to change the side broom sweep height. Recheck for proper sweep pattern after adjustment.

- Turn the adjustment knob counterclockwise to INCREASE the sweep pattern width.
- Turn the adjustment knob clockwise to DECREASE the sweep pattern width.

### REPLACING THE SIDE BROOM

Change the side brooms when the bristles become worn to less than 3 inches length.

1. Park the machine on a smooth level surface, turn key switch to "O" Position and engage parking brake.
2. Place the side brooms lever in the "UP" position.
3. Remove the lock pin that holds the broom flange to the motor shaft.
4. Disassemble the flange from the broom by removing the screws that hold the flange to the broom.
5. Assemble the flange to the replacement broom and fasten using the hardware removed.
6. Install the replacement broom on the shaft and insert the lockpin.

### HOPPER SERVICE

1. Park the machine on a smooth level surface.
2. Place the side broom lever in the "DOWN" position.
3. Move the brooms control lever to the "ON" position.
4. While staying in place allow the side broom to sweep for a short period of time. (Allow enough time for the side brooms to leave a clean footprint on the floor).
5. Place the side broom lever in the "UP" position.
6. Move the brooms control lever to the "OFF" position.
7. Back the sweeper away from the area where the pattern was left.
8. Turn the key switch to the "OFF" position and engage the parking brake.
9. Leave the operator's compartment and check the pattern to determine the floor contact area.
10. Determine if adjustment to the side brooms height is necessary by examining the floor contact area. The broom should contact the floor as shown in Figure 36. Adjust the side broom height if the contact area on the floor does not match the diagram.

**HOPPER SERVICE**

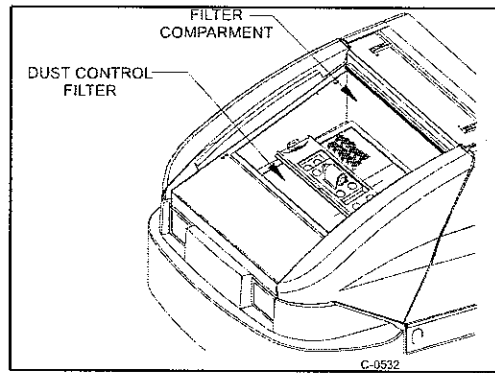

c0532 FIGURE 37

**HOPPER**

The hopper houses the debris compartment, the dust control filter and the removable dust baffle. For maximum performance and service life, keep the hopper clean and inspect the seals and flaps daily. Clean the hopper prior to parking the sweeper at the end of the day. A clean hopper will make inspecting the flaps and seals much easier and will prevent premature deterioration of hopper components. Do not leave the hopper full of debris while in storage or when parked for extended periods of time.

**CLEANING THE HOPPER**

Once the hopper has been emptied the insides of the hopper should be rinsed out with water.

**CHECKING THE HOPPER SEALS**

The hopper seals are important to positive dust control while sweeping. Damaged seals will reduce vacuum pressure at the broom. Inspect for cuts, tears and proper positioning of the seal material. Replace all seals that become damaged.

**DUST CONTROL FILTER**

The dust control filter should be checked daily for damage and cleaned if necessary. A damaged filter must be replaced to prevent damage to other dust control system components. Inspect the filter for tears in the filter media or excessive dirt lodged in the pleats. A tear in the filter media will allow dirt to pass through the filter and can be easily seen as a dirty patch on the top side on the filter. Cleaning of the filter is necessary when the filter shaker fails to adequately clean the pleats.

**CHECKING THE DUST CONTROL FILTER**

1. Park the machine on a smooth level surface, turn the key switch to the "O" position and engage the parking brake.
2. Raise the hopper lid for access to the filter compartment.
3. Turn the filter latch, lift the filter frame and remove the filter.
4. Inspect the panel filter for tears and clean or replace if necessary.
5. Reinstall the filter, lower the filter frame and engage the filter latch.
6. Close the hopper cover.

**CLEANING THE DUST CONTROL FILTER**

Clean the dust control filter when the shaker fails to adequately clear the filter. The filter can be cleaned with compressed air not to exceed 100 PSI.

To clean the filter with compressed air, apply the compressed air to the topside of the panel to backflush the lodged dirt from the filter pleats. Be careful to not damage the filter media while cleaning.

The filter can be cleaned with a solution of soap and water. If this cleaning method is used do not use the filter until it has completely dried.

## SERVICE INSTRUCTIONS

---

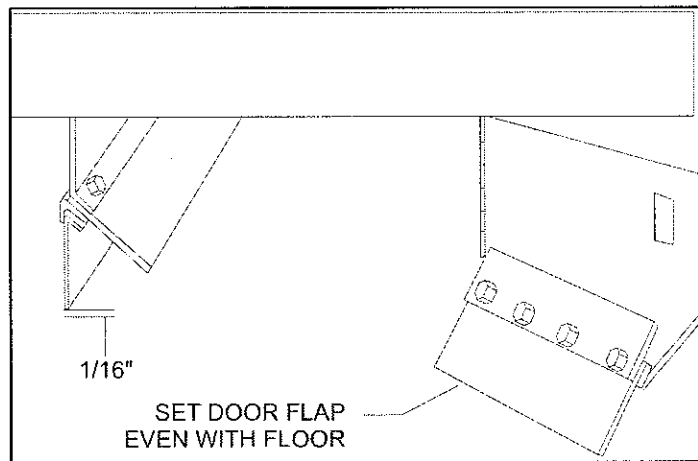

P4488A

FIGURE 38

### REPLACING THE DUST CONTROL FILTER

Change the filter panel when damage is evident.

1. Park the machine on a smooth level surface, turn the key switch to the "O" position and engage the parking brake.
2. Open the hopper compartment cover to gain access to the filter compartment.
3. Turn the latch on the hinged frame counterclockwise and lift the frame .
4. Remove the filter panel.
5. Install replacement filter, lower the hinged frame and engage the latch.
6. Lower the filter compartment cover.

### DUST FLAPS

The dust flaps are very important to sweeping and dust control and are susceptible to damage and should be inspected daily and maintained in good condition.

### CHECKING THE DUST FLAPS

The dust flaps are used on the wheel well, broom chamber and broom door. Inspect the flaps daily and replace any flap that shows signs of wear or deterioration. All flaps should be replaced when worn or damaged to the point that they can no longer perform their normal function. The adjustable flaps have slotted mounting holes to facilitate adjustment.

### ADJUSTING THE DUST FLAPS

Adjust the flaps so there is a 1/8" to 1/16" gap between the floor and the bottom edge of the flaps. The rear flap adjustment is 1/16" (16 cm.) above the floor.

1. Park the machine on a smooth level surface and engage the parking brake.
2. Loosen the flap retaining screws and adjust the flap to clear the floor and leave a 1/16" to 1/8" gap.
3. Tighten flap-retaining screws while holding flap in position.
4. Drive the machine on a smooth surface and recheck the flaps for proper floor clearance.

**BRAKE SERVICE**

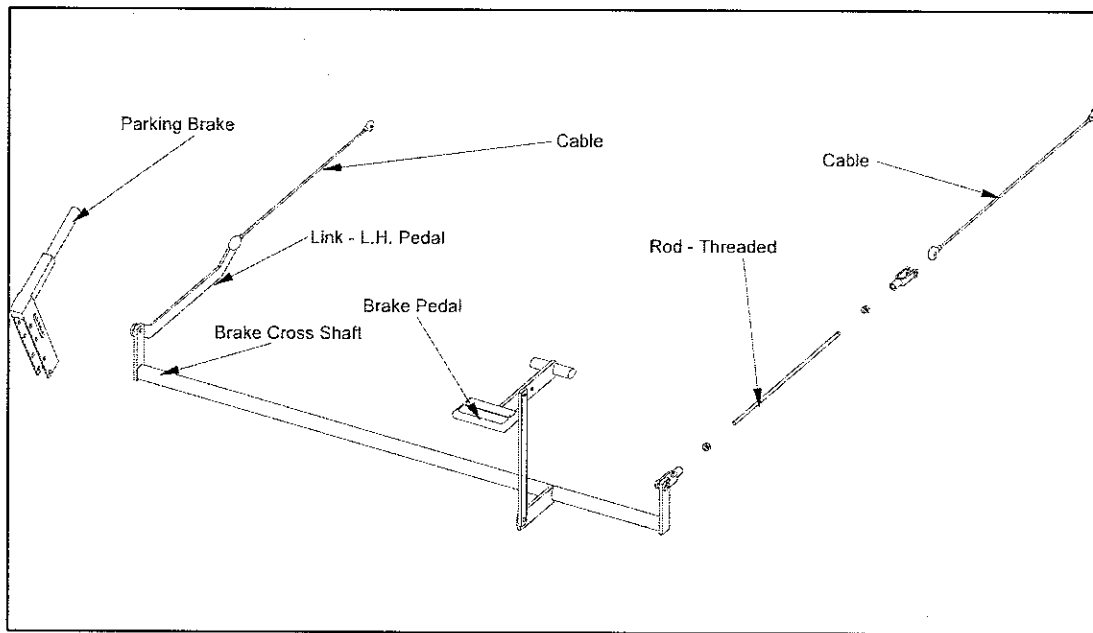

C1720

FIGURE 39

**BRAKES**

The service brakes are located on the front wheels and are operated by the brake pedal and the parking brake lever. Check the brakes daily for proper operation and inspect the brake pads for wear every 100 hours of operation.

**ADJUSTING THE BRAKE PEDAL**

Perform this adjustment to ensure proper pedal height and linkage operation. The brakes are properly adjusted when the brakes hold the sweeper on an 8-degree ramp. The brakes need adjusted if the Pedal travels closer than 1 inch to the floor of the operator's compartment when the brakes are fully engaged.



**WARNING**

The hopper could fall and cause serious injury.  
Always engage the hopper safety arm before working under the hopper.



**WARNING**

Always park on a level surface, chock tires and observe safety procedures when adjusting the brakes.

**ADJUSTING THE BRAKES**

When adjusting the brake clevis, follow these steps.

1. Right hand brake cable slack.
2. Adjust parking brake for maximum engagement.
3. With parking brake lever "off" check L.H. wheel must rotate with minimum drag. (Not completely free)
4. Adjust R.H. brake to provide minimum drag when released.

## GENERAL MACHINE MAINTENANCE

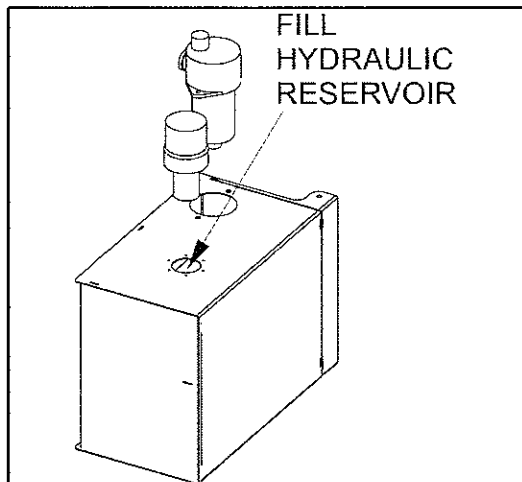

C1691A FIGURE 40

### FILLING THE HYDRAULIC RESERVOIR

1. Access to the hydraulic reservoir is located in the engine compartment.
2. Open the hydraulic reservoir breather filter cap.
3. Remove any debris that is in the breather filter cap screen.
4. Fill the reservoir until the fluid is at the "FULL" line on the hydraulic fluid sight gauge. The sight gauge is located on the center side of the hydraulic reservoir.
5. Close the hydraulic reservoir breather filter cap.
6. Close the engine compartment cover.

### CLEANING THE HYDRAULIC SYSTEM

1. Put a drop cloth on the floor.
2. Drive the machine onto the drop cloth.
3. Set the parking brake.
4. Open the engine covers.
5. Put a container under the reservoir drain to catch the reservoir fluid. Pivot the reservoir out.
6. Remove the drain plug. The reservoir fluid will drain. Do not use the drained fluid to refill the hydraulic reservoir. Dispose of the used fluid.
7. Flush the interior of the hydraulic reservoir with clean fluid.
8. Put the reservoir plug, removed in step six, back in the hydraulic tank drain and tighten it. A pipe thread sealer is required on the plug.
9. Open the breather filter cap.
10. Fill the reservoir with new FORD type "F" automotive transmission fluid. The capacity of the tank is 10 gallons. Fill to the "FULL" line on the hydraulic fluid sight gauge.
11. Close the breather filter cap. Rotate the reservoir into the engine compartment.
12. Replace the engine covers.

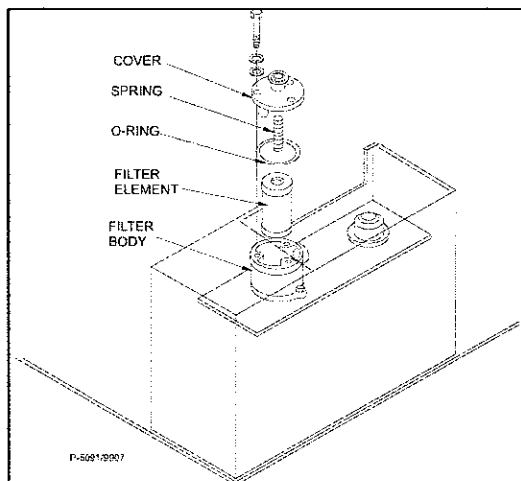

P5091 FIGURE 41

### REPLACING THE RETURN FILTER ELEMENT

1. Replace the return filter element after 250 hours of machine run time.
2. Unscrew the fasteners from the filter assembly cover and retain.
3. Remove the cover and the compression spring and retain.
4. Discard the old filter element.
5. Position the new filter element inside the filter body.
6. Put the compression spring in position. Wipe the cover magnet free of any metal filings or debris.
7. Place O-ring (moisten with clean hydraulic fluid) and cover into position.
8. Reattach fasteners to the filter cover.
9. Clean any hydraulic reservoir fluid spills. The fluid can damage painted surfaces of the machine.



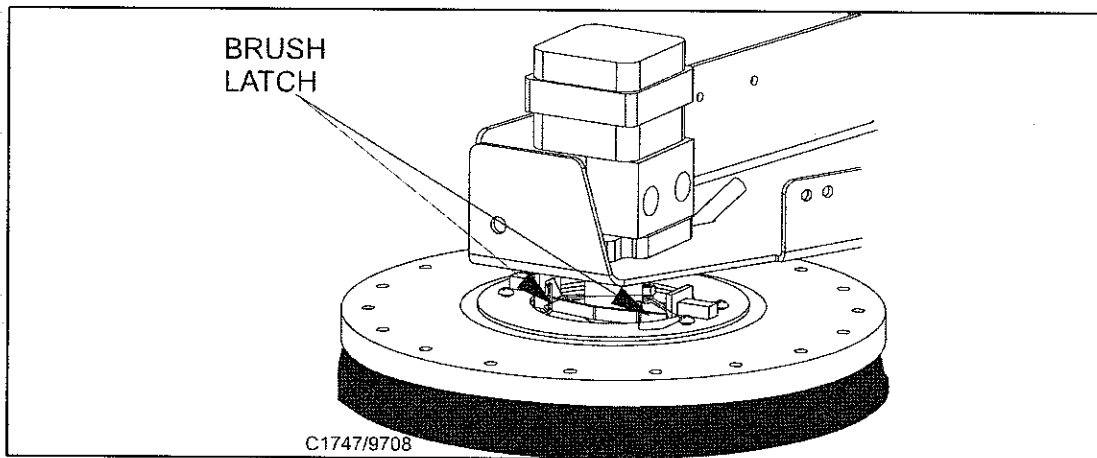

C1747

FIGURE 42

### REPLACING THE SCRUB BRUSH

1. Raise the scrub brush deck by pressing the "Scrub Brush" switch on the instrument panel.
2. Press the brush latches in to release the scrub brush.
3. Remove the old scrub brush.
4. Snap the new brush into place.

### COVERS AND LATCHES

The covers have been designed to allow access, either by hinge or removal, to all areas of the machine. No maintenance is required.

### SOLUTION LOW WARNING LIGHT

The solution low warning light will illuminate when the solution tank is low. This part of the level control system requires no maintenance. If the system fails to operate, consult the Electrical Troubleshooting Guide.

### RECOVERY HIGH WARNING LIGHT

The recovery high warning will illuminate approximately 5 minutes before loss of vacuum to the recovery tank. This part of the level control system requires no maintenance, except for daily cleaning of the tank level switch. If the system fails to operate, consult the Electrical Troubleshooting Guide.

### SOLUTION CONTROL (Non-Recycling or Standard)

The solution control lever controls the amount of solution applied to the scrubbing brushes.

The solution control should shut off completely with the lever in the (front) "off" position. If complete shut off does not occur, the control valve should be adjusted.

### SOLUTION CONTROL (Recycling or ESP System)

In the recycling mode, the solution control lever is also used to activate the detergent pump. If the detergent pump fails to operate (engine running) when the solution control lever is moved into the low to high range, first check the circuit by manually activating the switch. If the detergent pump does not operate at this time, a further electrical or mechanical check is required (see Electrical Troubleshooting Guide or Detergent Pump Troubleshooting).

## GENERAL MACHINE MAINTENANCE

### RECYCLING PUMP ESP SYSTEM

The recycling pump is located under the seat. The pump is electric and except for daily cleaning of the pump intake screens, it requires no regular maintenance.

### RECYCLING PUMP STORAGE

Always drain pump for extended storage, especially when freezing temperatures may be encountered.

### REAR SQUEEGEE

The squeegee will require service when the inner edges of the blades become round with wear, impairing the wiping action or water pickup. To service the rear squeegee use the following steps:

1. Loosen the four aluminum knobs (item 10, these hold the squeegee tool to the squeegee support).
2. Remove the squeegee tool and turn upside down to service the blades or caster wheels. The squeegee blades are designed to flip over and use another unworn edge (items 5 & 6).

#### To service the blades

1. Loosen the clamp bolts which clamp items 8 & 9 together.
2. Loosen far enough to slip the end clamp brackets off the squeegee tool. This will allow flipping the blades or installing new blades.
3. Install blades so that the outer blade is  $\frac{3}{16}$ " longer than the inner blades. This is achieved by assembling the top edge of the blade against the squeegee tool weldment.
4. Re-install the squeegee clamp band and tighten the clamp bolt.

### SQUEEGEE CASTER WHEELS

There are 2 grease fittings on each caster wheel. The casters should be greased each time the blades are serviced.

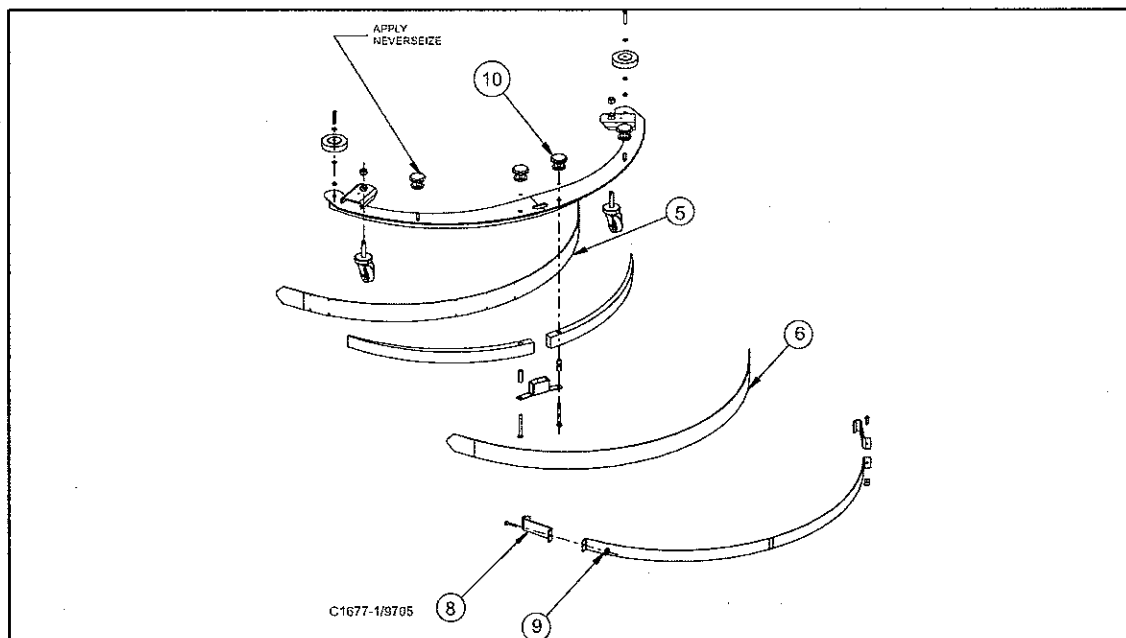

C1677-1

FIGURE 43

### ADJUSTING CASTERS

Lower the squeegee on a flat surface, making sure the rear squeegee blade is perpendicular to the surface. Adjust the caster  $\frac{3}{16}$ " above the flat surface. Lock the jam nuts.

## AIR INTAKE SYSTEM

### NOTE

Monitor the air filter indicator daily.

The importance of maintaining an air filter cannot be overemphasized. Dirt ingested through improperly installed, improperly serviced, or inadequate air filter elements wears out more engines than long hours of operation. Even a small amount of dirt will wear out a set of piston rings in just a few hours. Operating with a clogged air filter element also causes the fuel mixture to be richer, which can lead to the formation of harmful sludge deposits in the engine. Always cover the air intake when the air filter is removed for servicing. Do not neglect servicing the air filter. Use only approved replacement parts. Keep all other air intake components, such as hoses and clamps, secure and in good condition to prevent the entrance of unfiltered air.

Over maintenance can cause damage. Removing the air filter element more often than is needed allows contaminants to enter the engine unnecessarily.

### AIR FILTER

The engine air filter housing includes a dust cap and a dry cartage type air filter element. The dust cap must be emptied of dirt daily. The air filter element must be replaced every 75 to 100 hours. The filter element must be replaced if it is damaged or has been cleaned three times.

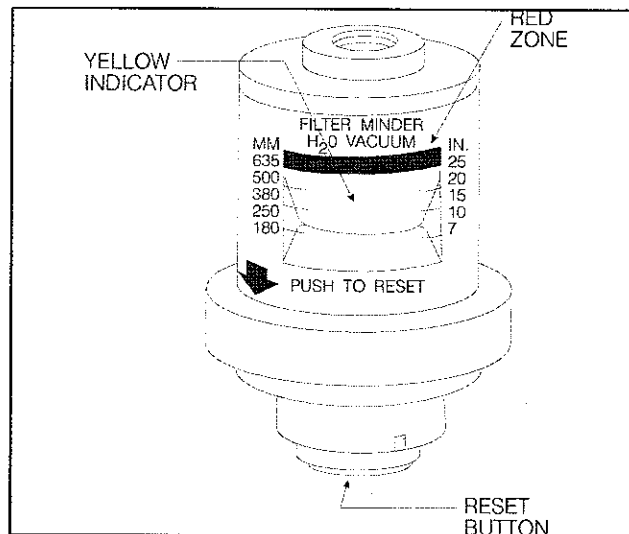

P4713

FIGURE 44

Replace the engine air filter only when the yellow Filter Service Indicator reaches the red band at the top of the indicator. The yellow indicator will stay at the red band when the engine is off. Reset the indicator by depressing the black button at the bottom of the indicator.

### REPLACING THE AIR FILTER ELEMENT

1. Stop the engine and engage the machine parking brake.



### WARNING

Always park on a level surface, stop the engine, and engage the parking brake before working on the machine to keep it from creeping or rolling.

2. Unscrew the clamp ring on the filter.
3. Remove the dust cap.
4. Empty the dust cap.
5. Remove the filter wing nut.
6. Gently pull the filter element out of the filter housing.

## GENERAL MACHINE MAINTENANCE

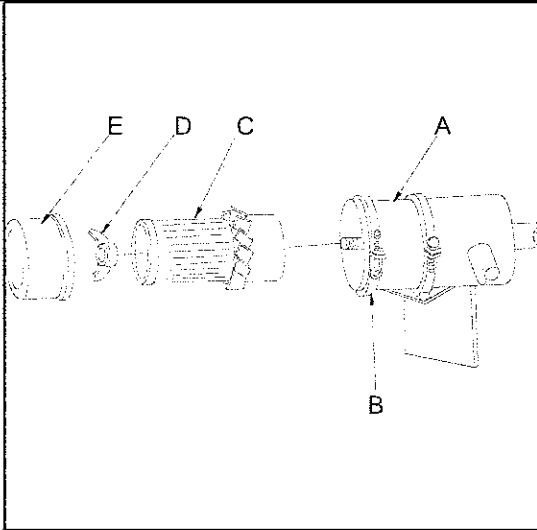

P4599-1 FIGURE 45

### REMOVING AIR FILTER ELEMENT

- A. Filter Housing
- B. Clamp Ring
- C. Filter Element
- D. Wing Nut
- E. Dust Cap

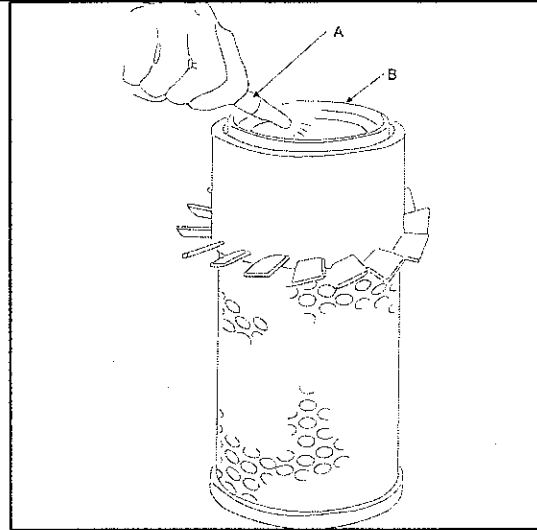

P4504 FIGURE 46

### CLEANING AIR FILTER ELEMENT

- A. Air Hose
- B. Filter Element

7. Clean the interior of the air cleaner housing with a damp cloth. Clean the element housing sealing surfaces.
8. Using an air hose, direct dry, clean air maximum 30 PSI up and down pleats on the inside of the filter. Do not rap, tap, or pound dust out of element.

### WARNING

Wear approved eye protection when using air or water hoses to prevent eye injury.

9. After cleaning the air filter element, inspect it for damage by placing a bright light inside. The slightest rupture requires replacement of the filter. Clean and inspect the ends of the element. They should be unbroken and flexible. Remember, the element must be replaced after it has been cleaned three times.

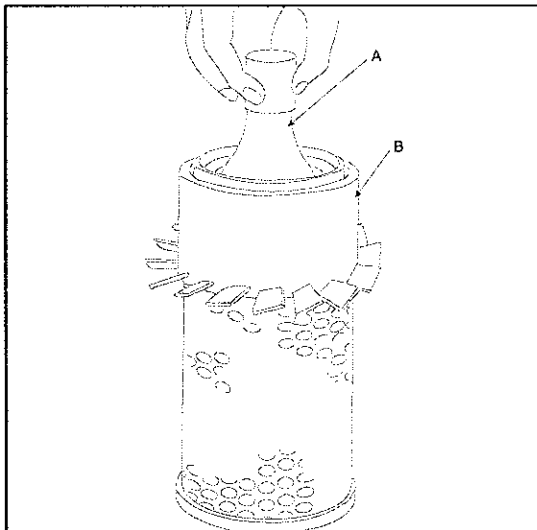

P4503 FIGURE 47

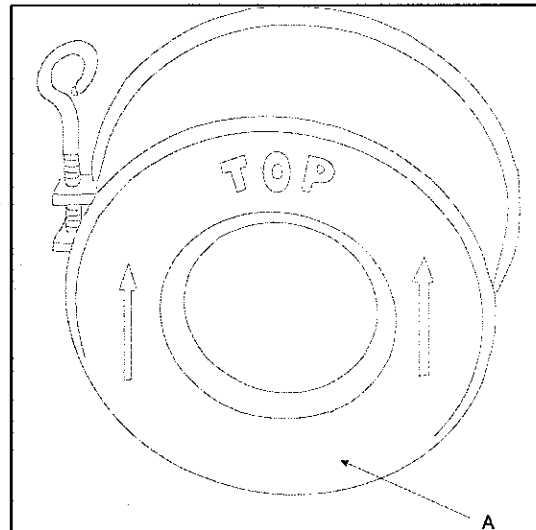

P4505 FIGURE 48

### INSPECTING THE AIR FILTER ELEMENT

- A. Bright Light
- B. Filter Element

### DUST CAP

- A. Dust Cap

10. Install the new or cleaned filter element so the fins on the element are at the intake end of the air cleaner. Use care so the fins are not damaged. Tighten the wing nut attaching the element.
11. Install the dust cap with the arrows pointing up. Tighten the clamp ring to hold it in place. Check all intake hose connections for leaks or abrasions.
12. Reset the filter monitor after any filter service.

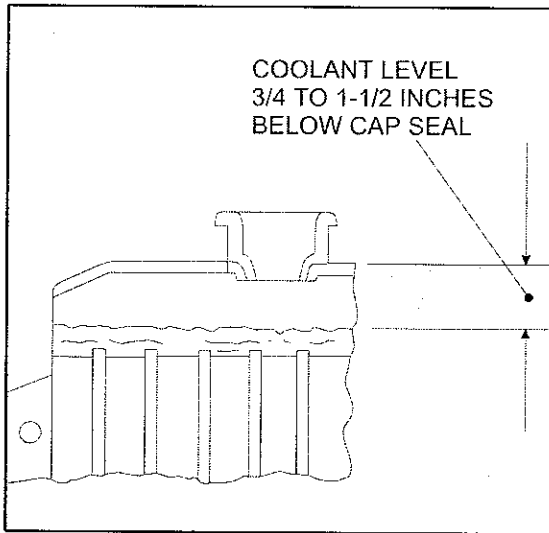

P4404-1

FIGURE 49

### COOLING SYSTEM

#### COOLANT LEVEL

Check the coolant level in the radiator daily, only when the engine is cool.

Maintain the coolant level at approximately  $\frac{3}{4}$  inches (1.9cm) below the filler neck seat on the radiator when the coolant is cool.

Whenever coolant level checks are made, check the condition of the radiator cap rubber seal. Make sure it is clean. Rinse off with clean water if necessary. When replacing the cap on the radiator, also make sure the radiator filler neck is clean.



### WARNING

Never remove the radiator cap under any conditions while the engine is operating. Failure to follow these instructions could result in damage to the cooling system or engine and/or personal injury. To avoid having scalding hot coolant or steam blow out of the radiator, use extreme care when removing the cap from a hot radiator. If possible, wait until the engine has cooled, then wrap a thick cloth around the radiator cap and turn it slowly to the first stop. Step back while the pressure is released from the cooling system. When you are sure all the pressure has been released, press down on the cap (still with a cloth) turn and remove it. Do not add coolant to an engine that has become overheated until the engine cools. Adding coolant to an extremely hot engine can result in a cracked block or cylinder head.

Use only a permanent type coolant that meets FORD specification ESE-M97B44-A such as FORD Cooling System Fluid. Refer to the coolant chart on the container for additional antifreeze protection information. Do not use alcohol or methanol antifreeze or mix them with the specified coolant. Plain water may be used in an emergency, but replace it with the specified coolant as quickly as possible to avoid damage to the system. With only water in the system, do not let the engine run hot.

### RADIATOR

Inspect the exterior of the radiator for obstructions. Remove all bugs, dirt or foreign material with a soft brush or cloth. Use care to avoid damaging the fins. If available, use compressed air or a stream of water in the opposite direction to normal airflow. Open door for access. Check all hoses and connections for leaks. If any of the hoses are cracked, frayed, or feel spongy, they should be replaced.

## GENERAL MACHINE MAINTENANCE

### DRIVE BELTS

The drive belt(s) should be properly adjusted at all times. Loose drive belts cause improper alternator, fan and water pump operation and overheating. Over tightening the belt may result in excessive wear on the alternator and water pump bearings, as well as premature wear on the belt itself. Therefore, it is recommended that proper belt tension be maintained.

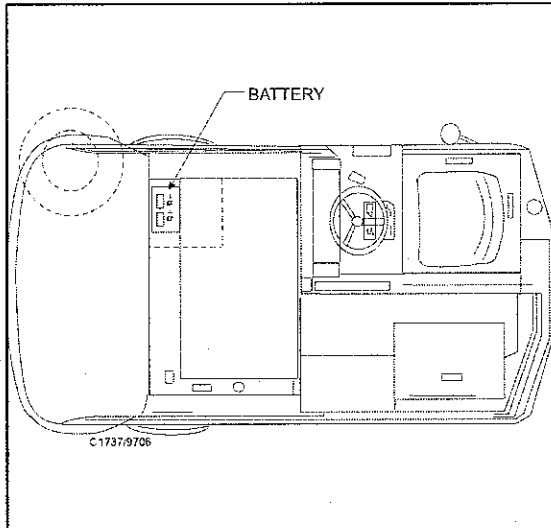

C1737

FIGURE 50

### BATTERY

The battery is located in front of the operator's compartment, in the engine area. Can be easily accessed through the hopper door. To remove the battery loosen bolt holding battery bracket in place.

Keep the top of the battery clean and dry. Keep the terminals and connectors clean. To clean the top of the battery, use a damp cloth with a weak solution of ammonia or bicarbonate of soda. To clean the terminals and connectors, use a terminal and connector-cleaning tool.



### WARNING

**NEVER** allow the soda solution to enter the cells.  
This will permanently discharge the battery.

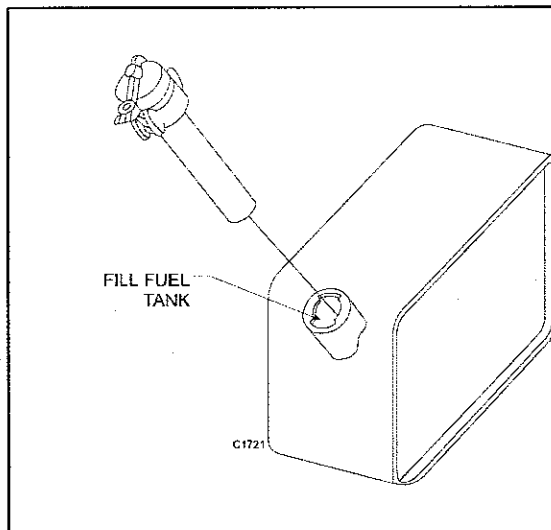

C1721

FIGURE 51

### GAS TANK

The gas tank is located under the driver's seat. It may be filled from the rear of the machine.

## GENERAL MACHINE MAINTENANCE

---

### LP GAS SYSTEM

The propane powered Model SC7750 is identical to the "standard" gasoline powered SC7750, except its fuel system has been modified to operate on LP vapor.

The LP fuel system consists of several components not found on the gasoline system. The LP fuel system also contains the associated mounting hardware and plumbing for the LP components. The major LP components are as follows:

1. An LP carburetor
2. A combination water heated vaporizer and regulator
3. A combination LP fuel line filter and lock off valve
4. An LP fuel tank and fittings.

These components are factory set; attempts at adjusting these components should only be made by authorized service personnel.

### LP GAS VAPORIZER-REGULATOR QUICK CHECK

Turn on the key switch and open the radiator cap. Check the coolant for bubbles. If bubbles are present, the vaporizer may have a leaking gasket or may have developed a pinhole leak, allowing the LP fuel to enter the cooling system.

### LP GAS FUEL TANK

The LP tank is located under the driver's seat. Use only the proper size and type of LP tank. The SC7750 LP powered sweeper/scrubber uses a 33.5 lb. Liquid withdraw tank. The DOT designation of the tank is DOT 4BW-240.

### NEUTRAL ADJUSTMENT

#### NOTE

Orientation of the transmission arm assembly depends upon which engine is installed in the SC7750 Sweeper Scrubber.

#### NOTE

Adjustment directions given are as seen from the operator's position in the driver's seat.

1. Check engine no load RPM; SC7750, 2050 RPM. Check hydraulic reservoir oil level.
2. Raise the rear of the machine onto jack stands so the rear wheel is off the ground.
3. Loosen the jam nut away from the adjustment nut.
4. If the rear drive wheel is turning forward, turn the adjustment nut counterclockwise (this will lengthen the threaded shaft). If the rear drive wheel is turning in reverse, turn the adjustment nut clockwise (this will shorten the threaded shaft).
5. Tighten the jam nut against the threaded shaft.
6. Test for operation of neutral with the engine at full throttle. If the rear drive wheel turns, repeat adjustment steps 3, 4 and 5.

## LP SAFETY PRECAUTIONS

---

 **WARNING**

Keep cigarettes, sparks, and open flames away when working on LP equipment, when inspecting for gas leaks, or when LP tanks are present.

 **WARNING**

Check all components for proper operation. Replace LP components when needed. Never bypass defective safety components.

 **WARNING**

Check routing of all LP hoses. Keep them away from sharp edges, exhaust manifolds, or other hot surfaces. Check for signs of abrasion or deterioration.

 **WARNING**

Check for gas odor before and during starting operations. If gas odor is noticed, stop and check for leaks or component malfunction.

 **WARNING**

Make sure the LP tank is free of dents or gouges.

 **WARNING**

Keep the engine properly tuned.

 **WARNING**

Make sure the LP tank is securely mounted on the machine with the retainer bracket clamping the tank and with the locating pin in position.

 **WARNING**

Make sure service coupling is clean and free of damage. Make sure service coupling of tank matches machine servicing coupling.

 **WARNING**

Park the machine in a shaded, cool area when not in use.

 **WARNING**

Keep the LP tank service valve closed when the tank is not in use.

 **WARNING**

Never overfill the LP tank. Fill the LP tank to the recommended weight stamped on the tank.

 **WARNING**

Use care in handling LP tanks. Never drop or drag them.

 **WARNING**

Always store and transport LP fuel tanks with the safety relief valve in the "UP" position.

 **WARNING**

Avoid contact with the LP fuel to avoid frostbite.

 **WARNING**

When the machine is to stand unused for a period of time (overnight), park it in a designated area. Shut off the service valve at the tank and operate engine until the remaining fuel is consumed. Turn off key.



## LP GAS COMPONENTS

### LP LIQUID WITHDRAWAL SYSTEM

The liquid LP fuel flows from the LP tank under its own pressure to the pressure relief valve. This valve is normally closed, which prevents LP fuel from escaping into the atmosphere. This LP gas is then piped to the LP fuel filter lock. The fuel filter lock removes unwanted tank scale and deposits from the LP gas. The vaporizer converts the liquid LP fuel into a gaseous LP fuel. This gaseous LP fuel is sent to the primary regulator. The primary regulator reduces the pressure of the LP tank and makes the flow more constant. The secondary regulator reduces LP gas pressure to the level required by the carburetor. From the secondary regulator, the LP fuel is piped to the carburetor where it is finally metered into the air flow which is sent to the combustion chamber.

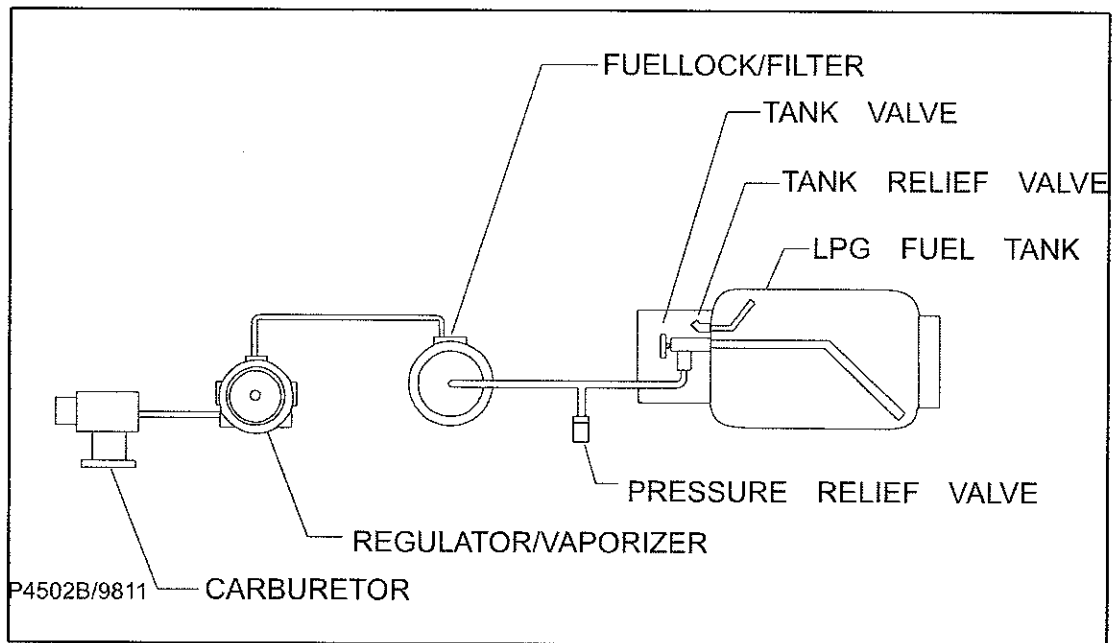

P4502B

FIGURE 53

## LP TANK COMPONENTS

### LP CHECKLIST

This checklist can be performed quickly and should be done before every use. Be sure to make all necessary checks as listed on the Maintenance Chart discussed earlier.

1. Check connections for leaks.
2. Open the LP storage tank valve.
3. Check the regulator. Momentarily press the fuel primer on the regulator cover to bleed air out of the system.

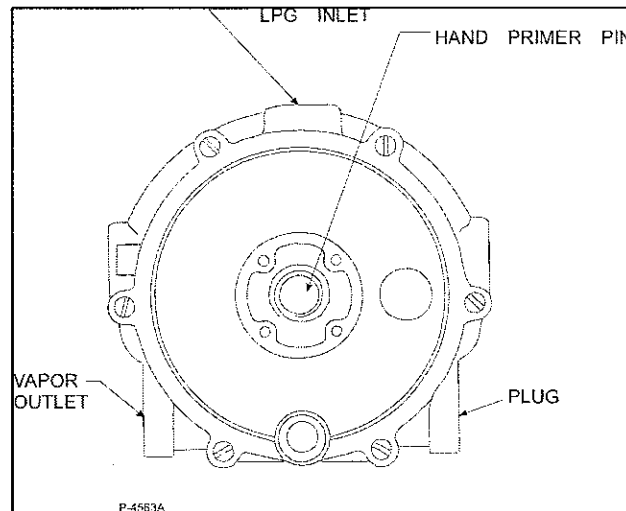

P4563A

FIGURE 54

4. Start the machine's engine.

### LP FUEL TANKS

Standard D.O.T. LP fuel tank sizes have 14, 20, 33.5, and 43.5 pound capacities. The liquid volume permitted in these containers is less than the total volume of the cylinder. This provides for expansion of the LP fuel in the case of a temperature increase above the normal amount. Excessive heat may cause the fuel to expand too much, causing the safety relief valve to vent some LP fuel, relieving internal tank pressure.

Each tank is marked showing the type of construction (liquid or vapor), the manufacturer, the date of manufacture, the capacity, the weight, and the date of requalification. D.O.T. fuel tanks must be requalified (checked) periodically. This requalification must be recorded and maintained for the life of the container.

LP fuel tanks are equipped with the following approved valves and fittings:

- \* Safety Relief Valve - This is a spring-loaded valve that relieves excessive pressures which may develop in the tank due to unusual conditions.
- \* Liquid Service Valve - Liquid is withdrawn from the tank through this valve. The LP tank may be filled through this valve if the tank is not equipped with a filter valve.
- \* Excessive Flow Valve - This valve is part of the liquid service valve. It is mounted inside the tank and prevents LP fuel from leaving the LP tank in the event of accidental breakage of external fittings or hoses.
- \* Filler Valve - This valve is optional. If this valve is not present, the tank is filled through the service valve.
- \* Liquid Level Gauge - This gauge is optional.

### USE AND CARE OF LP TANKS

If an LP tank is damaged or leaking, it should be immediately removed to a designated safe area and the proper personnel should be notified. Do not attempt to make repairs to the cylinder regardless of its condition. Repairs must be made by qualified personnel.

The care an LP tank receives has a direct bearing on how long the tank can be used safely. LP tanks must not be dropped, dragged, or slid across any surface. To move the LP tank, use a hand truck or roll the tank on its foot ring while it is being held in a position slightly off the vertical.

### CHANGING LP TANKS

Refueling machines with LP tanks is an important process. Refueling is accomplished by replacing the empty LP tank with a full tank.

The tank changing operation presents an opportunity for the machine operator to carefully inspect the tank, tank fittings, the fuel lines and fuel line fittings. If abnormal wear is detected, the operator should report these findings to the appropriate personnel for immediate action.

### CHANGING THE LP TANK

1. Park the machine in a designated safe area and set the parking brake.
2. Close the tank valve.
3. Remove the quick-disconnect coupling from the tank valve.
4. Inspect the machine's fuel lines and the quick-disconnect coupling for damage or abnormal wear.
5. Remove the empty tank from the holding device.
6. Inspect the tank and tank fittings for damage or abnormal wear. Handle the tank carefully. It must not be dropped or mishandled.
7. Store the LP tank in a designated safe area.
8. Select a full LP tank and observe for damage or leaks.
9. Carefully install the full tank in the machine so the tank-centering pin enters the aligning hole in the tank collar. This assures that the tank is positioned properly and allows for proper operation of the safety relief valve, liquid level gauge, and service valves.
10. Fasten the tank-retaining bracket so the tank is locked into position.
11. Reconnect the fuel line to the tank-servicing coupling.
12. Open the service valve slowly and check for leaks. If a leak is found, close the valve immediately and notify the appropriate personnel.
13. If no leaks are detected, the engine is ready to start. Do not start the engine unless the operator is in position with the directional control pedal in the neutral position.

### STORING LP FUEL TANKS

Whether the storage is inside or outside, the LP tanks should not be in the vicinity of combustible materials or high temperature sources such as ovens or furnaces. This may cause the heat to raise the pressure of the fuel to a point where the safety relief valves would begin operation. Care should be taken to ensure that the cylinders are stored in such a manner that if the safety relief valves are triggered, the vapor will be relieved rather than any liquid.

Valves on empty tanks must be closed during storage and transportation.

## **PARTS LIST LEGEND**

---

### **ABBREVIATIONS - SCREWS**

ADJ	= Adjusting Screw
ADJ.SP	= Adjusting Plunger Screw
BHM	= Binding Head Machine Screw
BHS	= Button Head Socket Screw
CAPT.SL	= Captivated Slotted Screw
CAPT.WG	= Captivated Wing Screw
FHM	= Flat Head Machine Screw
FIL.HM	= Filister Head Machine Screw
HHC	= Hexagon Head Cap Screw
HHM	= Hexagon Head Machine Screw
HIHD	= 1/2 High Head Screw
HSHC	= Hexagonal Socket Head Cap Screw
HSFHC	= Hexagonal Socket Flat Head Cap Screw
KNH	= Knurled Head Screw
MHHC	= Metric Hexagon Head Cap Screw
PHM	= Pan Head Machine Screw
RHD	= Round Head Drive Screw
RHM	= Round Head Machine Screw
RHW	= Round Head Wood Screw
SHC	= Shiny Crown Cap Screw
SHTB	= Shoulder Thumb Screw
SQ	= Square Head Screw
TB	= Thumb Screw
THM	= Truss Head Machine Screw
WELD	= Weld Stud
WG	= Wing Screw

### **ABBREVIATIONS - SETSCREWS**

HS	= Hexagonal Socket Setscrew
S	= Slotted Setscrew
SH	= Square Head Setscrew
-KCP	= Knurled Cup Point Setscrew
-CP	= Cup Point Setscrew
-OP	= Oval Point Setscrew
-FDP	= Full Dog Point Setscrew
-HDP	= Half Dog Point Setscrew
-FP	= Flat Point Setscrew
-COP	= Cone Point Setscrew

## GENERAL TROUBLESHOOTING

<u>PROBLEM</u>	<u>PROBABLE CAUSE</u>	<u>REMEDY</u>
Sweeping Does Not Function.	<ol style="list-style-type: none"> <li>1. Dump door open</li> <li>2. Hopper is raised</li> <li>3. Hopper switch out of adjustment</li> </ol>	<ol style="list-style-type: none"> <li>1. Close dump door.</li> <li>2. Lower hopper</li> <li>3. Adjust hopper switch</li> </ol>
Poor Water Pick-Up At Squeegee.	<ol style="list-style-type: none"> <li>1. Side or rear squeegee are worn or damaged.</li> <li>2. Clogging in water pick-up.</li> <li>3. Air leaks in suction hose and connection</li> <li>4. Air leaks at recovery tank cover and/or manifold gaskets.</li> <li>5. Poor vacuum</li> <li>6. Drain hose or drain plug leakage or not closed properly.</li> </ol>	<ol style="list-style-type: none"> <li>1. Examine squeegee rubber blade for cuts or worn spots. Replace if necessary.</li> <li>2. Repair or replace hose and connections.</li> <li>3. Repair or replace gaskets.</li> <li>4. Check vacuum motor.</li> <li>5. Check seal on recovery tank.</li> <li>6. Close, repair or replace drain plug in recovery tank.</li> </ol>
Water Spills From Squeegee.	<ol style="list-style-type: none"> <li>1. Side squeegee blades, poor contact with floor.</li> <li>2. Squeegee blades worn or damaged.</li> <li>3. Too much solution being applied before making turns.</li> <li>4. Brushes rotating opposite direction.</li> </ol>	<ol style="list-style-type: none"> <li>1. Readjust blades for proper contact.</li> <li>2. Replace and adjust</li> <li>3. Shut off solution flow 5 to 10 feet.</li> <li>4. Check position of switches</li> </ol>
Lack Of Suction At Rear.	<ol style="list-style-type: none"> <li>1. Clogged suction hose or pick-up tool.</li> <li>2. Loose connections between suction hose &amp; squeegee or between hoses of manifold inlet.</li> <li>3. Vacuum motor not operating.</li> <li>4. Vacuum float cage clogged.</li> <li>5. Vacuum float shut off</li> </ol>	<ol style="list-style-type: none"> <li>1. Disconnect suction hose from squeegee, flush squeegee &amp; hoses thoroughly.</li> <li>2. Check all hose connections for looseness or damage.</li> <li>3. Check hydraulic motor in recovery.</li> <li>4. Clean perforated metal thoroughly.</li> <li>5. Excessive solution in recovery drain tank. Excessive foam build up, change cleaning chemical mixture. Use A-L approved materials.</li> </ol>

## GENERAL TROUBLESHOOTING

<b>PROBLEM</b>	<b>PROBABLE CAUSE</b>	<b>REMEDY</b>
Poor Scrubbing	<ol style="list-style-type: none"> <li>1. Worn scrubbing brushes</li> <li>2. Incorrect method of operation</li> <li>3. Wrong cleaning agent or mixture</li> <li>4. Poor solution distribution</li> </ol>	<ol style="list-style-type: none"> <li>1. Inspect brushes. If they are worn to ½" (1.3 cm) or less, replace all 3 brushes</li> <li>2. Check scrubbing procedures, brush pressure, type of brush solution flow &amp; cleaning chemical used. For extreme conditions double scrubbing may be necessary.</li> <li>3. Use A-L recommended materials</li> <li>4. Clean out distribution tube &amp; metering holes to brushes. Checks feed hose &amp; clean if necessary. Check valve &amp; cable control system.</li> </ol>
Engine Runs, But Machine Will Not Move On Level Ground	<ol style="list-style-type: none"> <li>1. Foot pedal and/or linkage jammed or not adjusted.</li> <li>2. Front wheels jammed or brakes locked</li> <li>3. Hydraulic pump trouble.</li> <li>4. Rear wheel hydraulic motor, broken shaft key, broken shaft etc.</li> </ol>	<ol style="list-style-type: none"> <li>1. Check pedal linkage</li> <li>2. Check wheels &amp; brakes</li> <li>3. Check &amp; repair pump, check tow valve. See Cessna information</li> <li>4. Check &amp; repair. See Char-Lynn information.</li> </ol>
Machine Moves Slowly	<ol style="list-style-type: none"> <li>1. Low hydraulic oil level</li> <li>2. Brake dragging</li> <li>3. Hydraulic oil temperature too high</li> <li>4. Worn hydraulic pump or drive motor</li> </ol>	<ol style="list-style-type: none"> <li>1. Add oil to the reservoir</li> <li>2. Check brakes</li> <li>3. Check oil level. Add SAE 5 ATF if required</li> <li>4. See Cessna or Char-Lynn information</li> </ol>
Hydraulic Pump Making Excessive Noise	<ol style="list-style-type: none"> <li>1. Clogged inlet strainer or suction line</li> <li>2. Air bubbles in hydraulic fluid</li> <li>3. Hydraulic pump is worn or damaged</li> </ol>	<ol style="list-style-type: none"> <li>1. Clean inlet strainer line. Drain &amp; flush reservoir if oil is dirty. Refill with clean SAE 5 ATF.</li> <li>2. Check for low hydraulic fluid level, leaking fitting or hoses</li> <li>3. See Cessna pump information</li> </ol>

## ORDERING PARTS

Parts may be ordered from American-Lincoln® authorized distributors.  
Inspect the American-Lincoln® serial plate to avoid delays in filling your order:

<b>MODEL NO.</b>	<b>SERIAL NO.</b>
Manufactured By <b>AMERICAN-LINCOLN®</b>  <span style="float: right;">BOWLING GREEN, OHIO</span>	

1. Use the model number, catalog number, and serial number when ordering.
2. Give the part number, description, and quality of parts needed.
3. Give shipping instructions for either freight, UPS, or parcel post.

Parts and supplies listed in this manual can be ordered from the following address:

American-Lincoln	American Lincoln Distributor
1100 Haskins Road Bowling Green, Ohio 4302 1-800-331-7692	

### MACHINE CATALOG NUMBERS

505-817	FORD VARIABLE DUMP SC7750 46"
505-821	FORD VARIABLE DUMP SC7750 53"
505-820	BATTERY VARIABLE DUMP SC 7750 46"
505-824	BATTERY VARIABLE DUMP SC 7750 53"
505-818	LP VARIABLE DUMP SC 7750 46"
505-822	LP VARIABLE DUMP SC 7750 53"
505-819	DIESEL VARIABLE DUMP SC 7750 46"
505-823	DIESEL VARIABLE DUMP SC 7750 53"