

# User Manual Admiral 38C Cylindrical Sweeper/Scrubber



PowerBoss, Inc.  
A Member Of The Hako Group

## Introduction

### Preface

Dear Customer,

Please read this original manual thoroughly before starting the vehicle for the first time and keep it in the vicinity of the vehicle for future reference or subsequent owners.

We are certain that the excellent qualities of the vehicle will justify the faith you have shown in us through your purchase.

Please read the Chapter “Safety Information” prior to starting the vehicle to ensure it is operated and used safely. Your safety, and that of others, basically lies in your ability to control and operate the vehicle. Therefore, read the operating manual thoroughly before starting the vehicle up for the first time. The operating manual contains all the most important information regarding operation, maintenance and service. Throughout this operating manual, texts which concern safety are indicated by corresponding symbols.

Should you have any questions in respect of the vehicle or operating manual, your authorized PowerBoss dealer is available to provide help at any time. We would like to emphasize that no legal claims can be asserted in respect of any information provided in this manual. Please pay attention that only original spare parts should be used for any necessary maintenance and repair work. Only original spare parts can guarantee long, reliable equipment operation. We reserve the right to make technical improvements.

Valid as of: January 2010

**PowerBoss Inc.**  
**175 Anderson Street**  
**NC 28315 U.S.A.**  
**Telephone: (910) 944-2105**  
**Fax: (910) 944-740**

### Intended use

The Admiral 38C is a large-area scrubber-drier designed for wet cleaning rough and structured hard floors inside buildings, such as in multistorey car parks or logistics and industrial areas. Any use beyond this is regarded as improper use. The manufacturer is not considered liable for any damage resulting from improper use; the user is solely responsible for all the risks.



The Admiral 38C has not been approved for use on public paths and roads.

Intended use also includes maintaining and observing the operating, maintenance and repair conditions prescribed by the manufacturer.

The Admiral 38C may only be operated, serviced and repaired by personnel who are familiar with the work involved and are aware of the risks.

The applicable accident prevention laws must be observed and any generally accepted health and safety directives must be maintained.

Based on the conception, design and construction of the vehicle introduced onto the market by us, the vehicle complies with the applicable basic safety and health requirements stipulated in the EC Directive (refer to the Declaration of Conformity). This declaration is no longer considered valid in the event of modifications to the vehicle not authorized by us. The manufacturer is not deemed liable for any damage resulting from unauthorized modifications to the vehicle.

### Notes on warranty

The terms defined in the purchase agreement apply. Claims for compensation related to damage are excluded from the terms of warranty when the damage is the result of failure to observe regulations concerning service and maintenance. Maintenance work must be performed at authorized PowerBoss service centers and confirmed in the "Maintenance Report" which serves as a warranty logbook.

The following are excluded from the terms of warranty: wear and tear through over-use, defective fuses, improper handling or unauthorized modifications. Claims under the terms of warranty are annulled when damage occurs to the vehicle resulting from the use of parts or accessories not explicitly approved by us or from failure to observe maintenance regulations.

### Acceptance of the vehicle

The vehicle must be inspected directly after delivery for signs of transport damage. Replacement will be made when confirmation is provided immediately by the German Federal Railway (Deutsche Bahn AG) or the freight carrier with regard to the damage and the damage report is sent to us together with the consignment note:

**PowerBoss Inc.**  
**175 Anderson Street**  
**NC 28315 U.S.A.**  
**Telephone: (910) 944-2105**  
**Fax: (910) 944-740**

<b>Introduction . . . . .</b>	<b>2</b>	<b>3</b>	<b>Operation . . . . .</b>	<b>21</b>	3.4	After finishing work . . . . .	47
Preface . . . . .	2	3.1	Method of operation . . . . .	21	3.5	Function faults . . . . .	48
Intended use . . . . .	2	3.1.1	Rotary brush head . . . . .	21	3.5.1	Error code table . . . . .	48
Notes on warranty . . . . .	3	3.1.2	Squeegee . . . . .	23	3.5.2	Other function faults . . . . .	49
Acceptance of the vehicle . . . . .	3	3.1.3	Suction turbines (suction) . . . . .	24			
		3.1.4	Solution tank . . . . .	24	<b>4</b>	<b>Technical Data . . . . .</b>	<b>50</b>
<b>1</b>	<b>Safety Information . . . . .</b>	3.1.5	Recovery tank . . . . .	24	<b>5</b>	<b>Maintenance and Service . . . . .</b>	<b>56</b>
1.1	Safety and warning labels . . . . .	3.1.6	Traction drive . . . . .	25	5.1	PowerBoss system	
1.2	General information . . . . .	3.1.7	Brakes . . . . .	25		maintenance . . . . .	56
1.3	Operating information . . . . .	3.1.8	Batteries and charger . . . . .	25	5.2	Maintenance report . . . . .	57
1.4	Maintenance information . . . . .	3.1.9	Options . . . . .	26	5.3	Maintenance schedule . . . . .	58
1.5	Particular risks . . . . .	3.2	Operating and indicator		5.3.1	PowerBoss system	
1.5.1	Electronics . . . . .		elements . . . . .	29		maintenance, customer . . . . .	58
1.5.2	Batteries . . . . .	3.2.1	Operating elements in the		5.3.2	PowerBoss system	
1.6	Environmental protection . . . . .		driver's cab . . . . .	29		maintenance I . . . . .	60
1.7	Labels on the vehicle . . . . .	3.2.2	Left-hand operating panel . . . . .	32	5.3.3	PowerBoss system	
		3.2.3	Right-hand operating panel . . . . .	36		maintenance II . . . . .	63
<b>2</b>	<b>Starting Up . . . . .</b>	3.2.4	Operating elements on the		5.3.4	PowerBoss system	
2.1	Instruction . . . . .		vehicle . . . . .	39		maintenance III/S	
2.2	Initial battery charge . . . . .	3.3	Operation . . . . .	43		(safety check) . . . . .	64
2.3	Prior to starting up for the	3.3.1	Switching the vehicle on . . . . .	43			
	first time . . . . .	3.3.2	Accelerating . . . . .	43			
2.3.1	Installing the rotary brushes . . . . .	3.3.3	Stopping and parking . . . . .	44			
2.3.2	Installing and adjusting the	3.3.4	Cleaning . . . . .	44			
	squeegee . . . . .	3.3.5	Switching the vehicle off . . . . .	46			
2.3.3	Adjusting the driver's seat . . . . .	3.3.6	Loading and transporting				
2.4	Before starting up daily . . . . .		the vehicle . . . . .	46			

## Table of Contents





5.4	Battery system . . . . .	65	5.7	Rotary brush head . . . . .	75	5.10	Electrical installation. . . . .	83
5.4.1	Charging batteries . . . . .	66	5.7.1	Emptying and cleaning the waste container . . . . .	76	5.10.1	Red control lamps . . . . .	83
5.4.2	Servicing the driving batteries	67	5.7.2	Changing the rotary brushes. . . . .	77	5.10.2	Error codes. . . . .	83
5.4.3	Disassembling the batteries. . . . .	67	5.7.3	Cleaning the contact surfaces . . . . .	78	5.10.3	Fuses . . . . .	83
5.4.4	Installing the batteries . . . . .	67	5.7.4	Adjusting the locking lever for the brush holder . . . . .	78	5.10.4	Drive control relay . . . . .	83
5.4.5	Disposing of batteries. . . . .	69	5.7.5	Installing new rubber deflector strips . . . . .	79	5.11	Cleaning the vehicle. . . . .	84
5.4.6	Total discharge signal transducer (TSG) . . . . .	69	5.7.6	Adjusting the rotary brush head . . . . .	79	5.12	Transporting and towing Loading . . . . .	84
5.5	Solution tank . . . . .	70	5.7.7	Direction of rotation of the rotary brushes . . . . .	80	<b>6</b>	<b>WARRANTY . . . . .</b>	<b>86</b>
5.5.1	Filling the solution tank. . . . .	71	5.8	Squeegee. . . . .	81			
5.5.2	Emptying the solution tank. . . . .	71	5.8.1	Cleaning the squeegee . . . . .	81			
5.5.3	Cleaning the draining hose cap. . . . .	71	5.8.2	Disassembling the squeegee . . . . .	81			
5.5.4	Cleaning the filter in the solution feed. . . . .	71	5.8.3	Installing the squeegee . . . . .	81			
5.6	Recovery tank . . . . .	72	5.8.4	Changing the sealing strips . . . . .	82			
5.6.1	Emptying the recovery tank . . . . .	73	5.9	Wheels . . . . .	82			
5.6.2	Cleaning the recovery tank . . . . .	73	5.9.1	Front wheel. . . . .	82			
5.6.3	Cleaning the draining hose cap. . . . .	74	5.9.2	Rear wheels . . . . .	82			
5.6.4	Cleaning the air intake filter . . . . .	74						
5.6.5	Cleaning the openings to the solution tank. . . . .	74						

## 1 Safety Information

### 1.1 Safety and warning labels

All texts related to personal safety, safety of the vehicle and environmental protection are assigned the following symbols throughout the operating manual:

Symbol	Hazardous for ...	Definition
Danger 	persons or property	Safety information to prevent the development of hazardous situations resulting from ignoring or failing to follow instructions or prescribed work procedures.
Note 	the equipment	Important information on handling the equipment in order to maintain its operability.
Ecological hazard 	the environment	Risk to the environment through using substances which represent a health or pollution hazard.

### 1.2 General information

- The Admiral 38C fulfills all the applicable safety and health requirements stipulated in the EU directives with regard to its planning, constructional design and final construction as introduced by us onto the market. In the case of modifications to the vehicle not approved by us, the EC Declaration of Conformity enclosed in this operating manual loses its validity.
- In addition to the information provided in this operating manual, all legally applicable health and safety provisions must be observed.
- Before starting up the vehicle for the first time, read the operating manual supplied with it thoroughly as well as any separate manuals provided with additional or attachment devices and observe all the information during work.
- The vehicle may only be operated, maintained and repaired by persons trained by PowerBoss or authorized to do so by PowerBoss.

- Particular attention should be paid to the information regarding safety. Technical expertise is the key to preventing errors when operating the equipment and ensuring trouble-free operation.
- The operating manual must always be kept at the operating location of the vehicle and, as a result, should be kept in a safe place on the vehicle.
- If the equipment is sold or rented out, these documents should be transferred to the new owner/operator. The transfer should be confirmed!
- The warning labels attached to the equipment provide important information concerning safe operation. Labels which are illegible or missing must be replaced.
- Original spare parts must be used to ensure safety.
- If you want to shut the vehicle down, render it inoperable. It must not represent a source of danger for children.

### 1.3 Operating information

- Before starting the vehicle up for the first time, the battery to be used must be fully charged, properly, by implementing the initial battery charge routine. Please pay attention to the operating manual provided with the charging unit as well as the manual from the battery manufacturer. PowerBoss assumes no liability for damage to the battery caused by a fault when the battery is charged for the first time.
- Before starting the vehicle up, always check it is in a proper condition and that it is safe to drive and operate. Clear up any faults and defects immediately! Never operate the vehicle without functional safety equipment.
- Warning: Do not use the vehicle without a protective roof structure (refer to "Accessories", "Cab safety roof") in areas where the driver is at risk of being hit by falling objects (e.g. warehouses). Contact the trade association responsible for you as to whether obligations exist in this respect.

- The Admiral 38C must be subjected to an inspection in respect of its operationally safe condition at least once a year by an authorized technical expert. The results of the inspection must be documented in writing and kept safe at least until the next inspection.
- Floor cleaning vehicles may only be operated by suitable personnel who have been trained to operate the equipment, have proven their capability to operate the vehicle to the contractor or person appointed by him and have been explicitly charged by him to operate the vehicle.
- Before starting work, operating personnel must be fully familiar with all adjustment, operating and control elements as well as their respective function! It is too late to do this when the vehicle is actually in operation!
- The warning labels attached to the Admiral provide important information concerning safe operation.
- Wet floors are a potential risk for slipping! Ensure to provide the corresponding information and warning signs.
- If the floor is excessively wet, check the vehicle for leaks and that the sealing strips are in a good condition. If the sealing strips are damaged, change them immediately.
- Only use cleaning agents suitable for the vendor (non-foaming) and observe all the use, disposal and warning information provided by the cleaning agent manufacturer.
- It is forbidden to use the vehicle in potentially explosive atmospheres.
- The machine is not suitable for clearing up health-hazardous, inflammable or explosive fluids, dust or substances.
- Ride-on equipment may only be set into motion from the seat (seat contact switch).
- The seat contact switch must never be bypassed or the function immobilized in any way (e.g. by placing a heavy load on the seat).
- It is forbidden to transport people on the vehicle!
- Always wear heavy duty, non-slip footwear when working with the vehicle.
- Start driving immediately after switching on the brush head drive, otherwise imprints of the brush could be produced on the floor.
- The machine may only be driven on and the equipment used on those surfaces which have been approved by the contractor or person appointed by him.
- The manner of driving must be adapted to the local conditions (floor characteristics, presence of persons in the vicinity, obstacles, etc.).
- When using the vehicle, it is essential to pay attention to third parties, especially children.
- Never leave the vehicle unattended while motors are still running and it has not been locked against unintended movement.
- To prevent authorized use of the vehicle, lock the drive by removing the key from the key switch.
- When transporting the vehicle, the motors must be shutdown.
- Only open empty recovery tanks.
- The vehicle may only be driven on gradients to a maximum of 6% for a maximum of five minutes. Do not drive the vehicle on slopes with a gradient steeper than the limit gradient indicated on the machine.



### 1.4 Maintenance information

Properly completed vehicle maintenance is an important protective measure for preventing accidents.

- The maintenance work and maintenance intervals prescribed in the operating manual must be adhered to.
- Operating personnel must complete the necessary daily and weekly maintenance work. All other maintenance work must be completed at your nearest authorized PowerBoss service center.
- Before starting any cleaning and maintenance work or replacing parts, switch off the engine and motors, remove the key from the key switch and pull out the battery plug. This is particularly important in respect of work on the electrical system!
- Before working on the brushes, switch off the scrubbing unit, set the key switch to position 0 and remove the key.
- The scrubbing unit may only be disassembled and installed by service personnel.
- Suitable tools must be used for cleaning and maintenance work.
- Spare parts must comply with the minimum technical requirements stipulated by the manufacturer! This is ensured by the use of original spare parts.
- When working in the area of the raised seat console, it must be pivoted up fully to prevent it accidentally closing or suddenly slamming shut.
- It is not permitted to clean the vehicle with a pressure washer or steam blaster.
- Clean the recovery tank regularly to protect it from the accumulation of dirt, viruses, bacteria, etc.
- It is not permitted to use aggressive and corrosive cleaning agents.
- Allow the vehicle to dry after being cleaned, e.g. over the weekend.
- The vehicle must be checked by a recognized technical expert in respect of operational safety at reasonable intervals (we recommend at least one a year), particularly with regard to protective equipment and locks and following modifications or repair.
- Only start the vehicle up when all the safety equipment has been installed, is functional and brought to its protecting position.
- The vehicle has been set up for operation using low-maintenance trough batteries. If other battery types are to be used, the vehicle must be adjusted for them at an authorized PowerBoss service center.
- Observe the information in the operating manual provided by the battery manufacturer. It must be available to operating and maintenance personnel at all times.
- Batteries may only be handled and changed by properly skilled maintenance personnel.
- When installing the trough battery, use appropriate lifting gear.
- Only use the batteries prescribed by us and original chargers to charge them. The full terms of warranty can only be accepted when these units are used.
- Pay attention that the insulation on the charger is not initially damaged and not damaged during the charging process. The cable must not rub against

anything. Do not use the charger if the insulation is damaged.

- Always wear appropriate protective clothing when handling the battery (e.g. protective gloves, finger stalls, protective goggles).
- The seat console must be pivoted open during the battery charging process to prevent the development of explosive oxyhydrogen!
- Never leave the batteries in a discharged state but recharge them as soon as possible.
- Only refill distilled water.
- When the cells are in good condition, never refill the battery acid.
- Spilled battery acid must never enter the sewage system in its initial form, it must be neutralized beforehand.
- Pay attention to legal requirements and local directives.
- For further safety information, see supplementary sheet 88-60-2554 "Notes on driving batteries".

## **1.5 Particular risks**

- The following applies when locating the cause of faults and clearing them: Switch the vehicle off, remove the key and disconnect the battery plug!
- In the case of faults involving the traction drive, stop the vehicle immediately and remove the key from the key switch!

### **1.5.1 Electronics**

- Always disconnect the battery plug before starting any work on the electrical installations.
- Only use original fuses with the prescribed amperage.
- In the case of defects in the electrical installation, switch the vehicle off immediately and clear the fault.
- Work on the electrical equipment may only be carried out by electricians who have received the necessary training and in accordance with the electrical engineering regulations.
- The vehicle's electrical equipment must be inspected/checked at regular intervals. Defects, such as loose connections and cable damage, must be rectified immediately.

### **1.5.2 Batteries**

- Due to a change in the center of gravity, only approved batteries may be installed at the intended position.
- To prevent creeping currents, always keep the batteries clean and dry and protect them from contamination, e.g. from metal dust.
- Never lay any metallic objects or tools on batteries. Risk of short circuit and deflagration!
- Ensure sufficient ventilation in the charging area when charging the batteries. Otherwise there is a risk of explosion!
- The seat console must be pivoted open during the battery charging process to prevent the development of explosive oxyhydrogen!
- Only use the original charger! Pay attention that the insulation is not initially damaged and not damaged during the charging process. The cable must not rub against anything. Do not use the charger if the insulation is damaged.

- Ensure there are no naked flames nearby when handling batteries, particularly when checking the acidity. Risk of explosion!
- Do not inhale battery gases.
- Battery acid is very corrosive; keep away from children.
- Wear protective goggles when controlling the acid level.
- In the event of acid splashing in the eyes, rinse them with water for approx. 15 minutes and seek medical attention immediately.
- Also pay attention to the information in Section 1.4.

### **1.6 Environmental protection**

- A certain factual expertise is required in order to use substances which could represent a risk to health and the environment.
- Always observe legal regulations and local directives when disposing of cleaning agents.
- Used batteries with the recycling symbol contain reusable commodities. The heavy metals contained represent a major risk both to people's health and to the environment. Never open or damage batteries. Never touch, inhale or swallow the content of batteries. Health hazard! Do not allow batteries to get into the environment. Risk of contaminating the ground and water! In accordance with the symbol with the crossed out garbage bin, these batteries must not be disposed of in domestic waste. Return and recycling of old batteries must be agreed on with PowerBoss' authorized dealers.

- Dispose of the equipment in accordance with local regulations. For further information on handling and recycling, please contact the authorized PowerBoss dealer where you purchased the equipment.

### 1.7 Labels on the vehicle

The following safety and warning labels are attached to the vehicle where easily legible. Refer to Fig 1 to Fig 3 for item locations.

 Missing or illegible labels must be replaced immediately.

(1) Company logo



(2) Read the operating manual, maximum gradient and ban on cleaning using a high-pressure washer.



(3) Rating plate, The rating plate is in the driver's cab, at the bottom, on the flap of the left-hand electrical compartment.

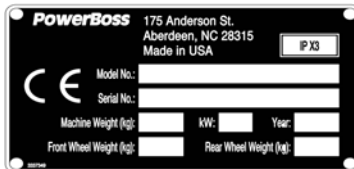

Fig 1 Label locations 1

- (4) Maximum water temperature for solution to be filled



- (5) Drive direction selector:  
Forward or reverse



- (6) Release parking brake



- (7) Apply parking brake

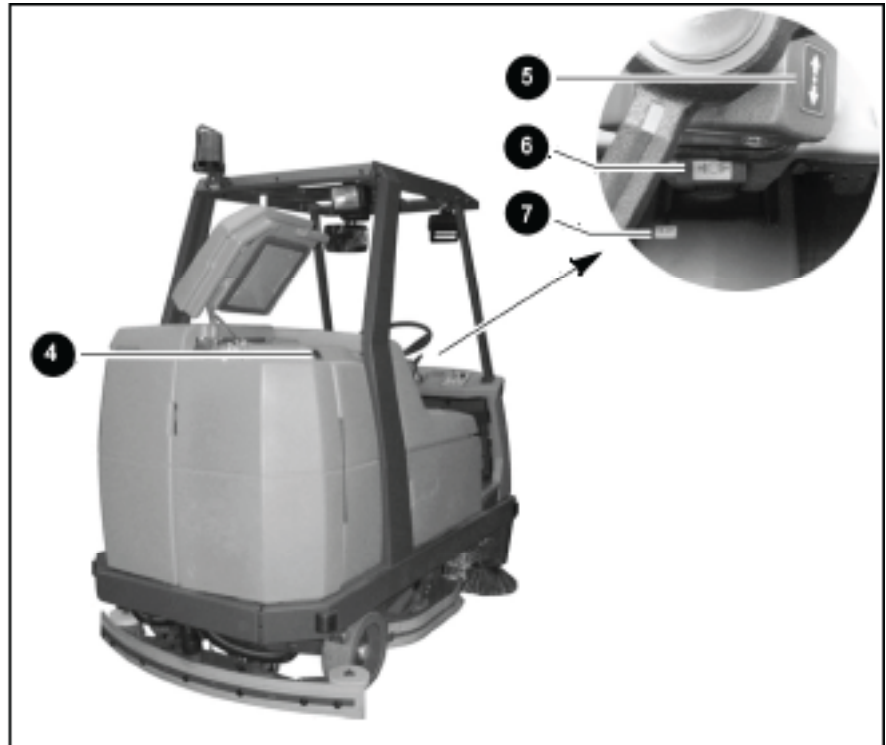

**Fig 2 Label locations 2**

(8) Waste water drainage

The waste water is drained via the hose which hangs to the right of this label.

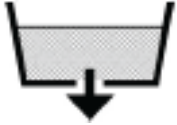

(9) No waste water drainage

The flap serves exclusively for cleaning and maintenance of the waste water tank.



(10) Solution drainage

The solution is drained via the hose which hangs to the left of this label.

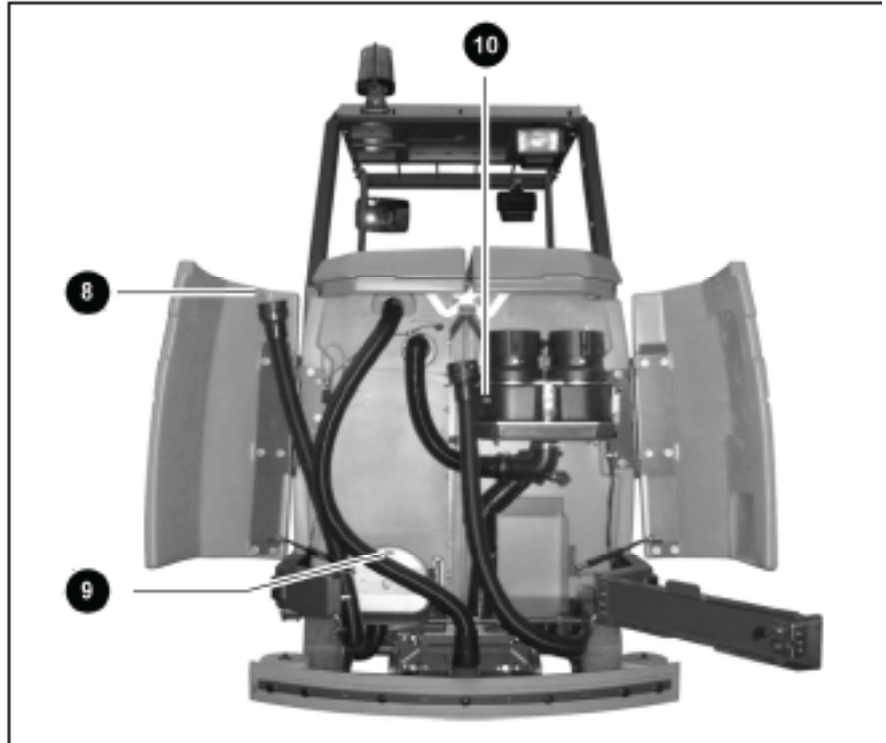

**Fig 3 Label locations 3**

## 2 Starting Up



Pay attention to persons in the vicinity of the vehicle when completing any work.



Before starting the vehicle up for the first time, the batteries to be used must be fully charged, properly, by implementing the initial battery charge routine. PowerBoss assumes no liability for damage to the battery caused by a fault when the battery is charged for the first time.



The seat console must be pivoted open during the battery charging process to prevent the development of explosive oxyhydrogen!



Only use the original charger! Pay attention that the insulation is not initially damaged and not damaged during the charging process. The cable must not rub against anything. Do not use the charger if the insulation is damaged.

### 2.1 Instruction

Instructions to operators are required before putting the vehicle into service. Only technicians from your local authorized PowerBoss dealer are allowed to provide initial instruction on the vehicle. The manufacturing plant will notify the dealer immediately after delivering the vehicle and the dealer will contact you to arrange a date.

### 2.2 Initial battery charge

An initial battery charge must be performed in order for it to provide an optimum performance and service life. A battery charger is available which is specially adapted to the batteries.



Only use the batteries and charger prescribed by us to charge the battery. The full terms of warranty can only be accepted when these units are used.



Do not inhale battery gases.

Please pay attention to the operating manual provided with the charging unit as well as the manual from the battery manufacturer. Powering up the batteries is described in such detail in the manufacturer's documents that further information on the subject is considered unnecessary for this manual.

## 2.3 Prior to starting up for the first time

The following work must be completed before starting the vehicle up for the first time:

### 2.3.1 Installing the rotary brushes

Two rotary brushes must be fitted in the rotary brush head. These rotary brushes are not part of the scope of delivery supplied with the vehicle. Choose the rotary brushes separately according to the task to be completed (refer to Section 4). If you ordered the rotary brushes together with the vehicle, the rotary brushes are normally already installed by the authorized PowerBoss dealer prior to delivery.



Check whether rotary brushes are fitted.

If no rotary brushes are installed, proceed as follows to install them.



The following applies to all work on the rotary brushes: Turn the key switch to position 0, remove the key and apply the parking brake (Fig. 14/8).



The front rotary brush is changed from the right-hand side of the vehicle, the rear rotary brush from the left-hand side of the vehicle.

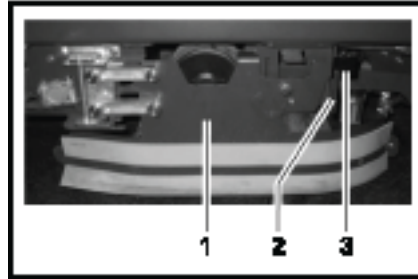

**Fig 4**

- (1) Deflector
- (2) Deflector lock
- (3) Grip

1. Open the deflector (Fig. 4/1): take hold of the grip (Fig. 4/3), raise the deflector (Fig. 4/1), pivot open towards the front and set it down (service position).

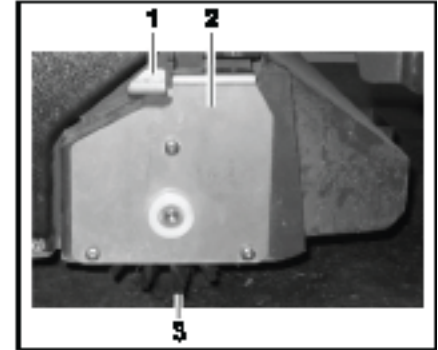

**Fig 5**

- (1) Locking lever
  - (2) Brush holder
  - (3) Rotary brush
2. Slide the locking lever (Fig. 5/1) for the brush holder (Fig. 5/2) to the middle of the device and hold it there.
  3. Allow the brush holder (Fig. 5/2) to lower down and remove it.
  4. Release the locking lever (Fig. 5/1).
  5. If necessary, remove the existing rotary brush (Fig. 5/13) from the housing (Fig. 6/1).



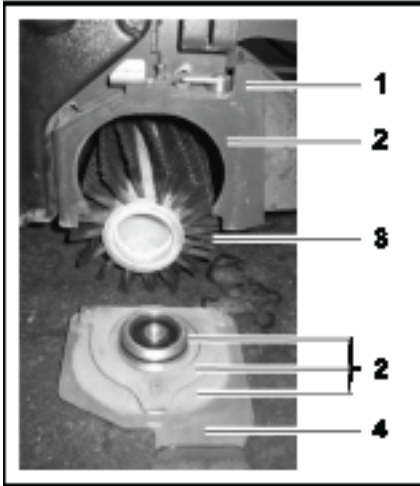

**Fig 6**

- (1) Housing
- (2) Contact surfaces
- (3) Rotary brush
- (4) Brush holder (removed)

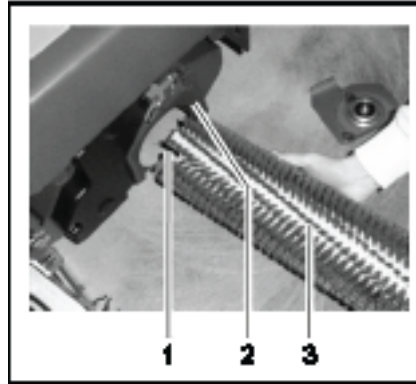

**Fig 7**

- (1) Catch
  - (2) Housing
  - (3) Rotary brush
6. Lay one hand under the rotary brush (Fig. 7/3) and slide it together with the catches (Fig. 7/1) into the housing (Fig. 7/2).

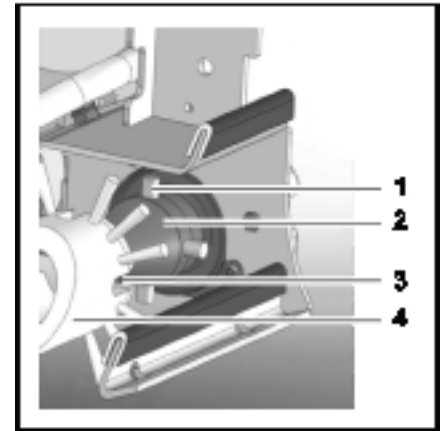

**Fig 8**

- (1) Pin
  - (2) Brush support
  - (3) Catch
  - (4) Rotary brush
7. To slide the rotary brush (Fig. 8/4) on the facing brush support (Fig. 8/2), raise the rotary brush (Fig. 8/4) a little and turn slightly, if necessary, until the catches (Fig. 8/3) perceptibly slide from the rotary brush (Fig. 8/4) onto the pins (Fig. 8/1) of the brush support (Fig. 8/2).



Ensure that the contact surfaces (Fig. 6/2) are clean. Clean them thoroughly, if necessary, before fitting them on the brush holder (Fig. 6/4).

8. Slide the locking lever (Fig. 5/1) to the middle of the device and hold it there.
9. Mount the brush holder (Fig. 6/4) on the rotary brush (Fig. 6/3), press against the housing (Fig. 6/1) and then slide upwards.
10. Pivot the locking lever (Fig. 5/1) back under the brush holder (Fig. 6/4) to the stop.
11. Close the deflector (Fig. 4/1):  
Take hold of the grip (Fig. 4/3), raise the deflector (Fig. 4/1), pivot to the device and lower into the deflector lock (Fig. 4/2). The deflector (Fig. 4/1) is now in its working position.

### 2.3.2 Installing and adjusting the squeegee

#### Installing the squeegee

1. Switch on the key switch.
2. Lower the squeegee holding attachment: Press the button for the squeegee and suction turbine so that the green control lamp lights up.
3. Switch off the key switch and remove the key.
4. Open the rear doors.
5. Slide the squeegee from the rear under the lowered holding attachment and fix the squeegee to it with the four wing nuts (Fig. 9/1).
6. Attach the suction hose to the connection nozzle (Fig. 9/2) of the squeegee.
7. Insert the key in the key switch and turn the key switch on.
8. The squeegee is then lifted automatically.
9. Close the rear doors.

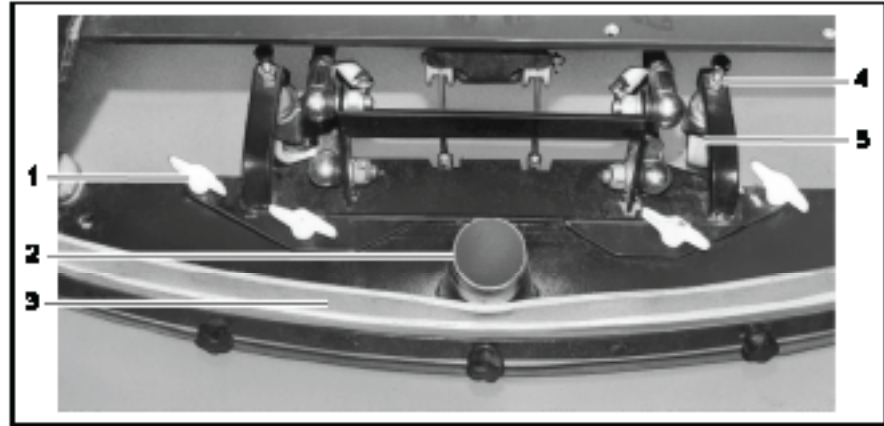

**Fig 9**

#### Adjusting the squeegee

The squeegee must be set up on a level floor according to the conditions in which it is to be used. The squeegee must stand vertically on the floor (adjusted at the factory). The sealing strip (Fig. 9/3) should bend slightly to the rear when the vehicle is in operation. Supporting rollers (Fig. 9/5) limit its movement toward the floor. To increase the squeegee contact pressure, the supporting rollers must be adjusted:

- Loosen the counternuts (Fig. 9/4) and raise the supporting rollers on the left and right evenly (turn screw counter-clockwise and lock again).

The sealing strip now bends a little more towards the rear. An adjustment of the supporting rollers is also necessary when the edge of the sealing strip is worn.

### 2.3.3 Adjusting the driver's seat

The driver's seat (Fig. 10) must be adjusted so that the driver is seated comfortably and can reach all the operating elements with ease.



The vehicle is equipped with a seat contact switch. The vehicle can only be operated when the operating person is seated on the seat.

The Admiral 38C is equipped with a driver's seat which can be adjusted in a longitudinal direction (forward and back):

1. Force the lever on the right of the seat outwards slightly.
2. Slide the seat forward or back in steps of 0.6 in.

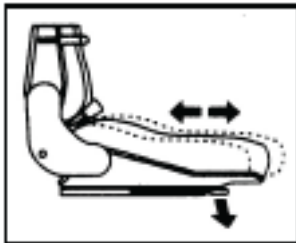

**Fig 10**

### 2.4 Before starting up daily

Carry out the following checks before starting the vehicle up for its daily operation (also refer to Section 5.3.2):

1. Check the recovery tank, empty as necessary. Clean it as necessary. Refer to Sections 5.6.1 and 5.6.2.
2. Check the waste container; empty and clean it, if necessary; refer to Section 5.7.1.
3. Fill the solution tank and cleaning agent in accordance with the manufacturer's mixing directives. Refer to Section 3.1.4 and Section 5.5.1.



Only use cleaning agents (non-foaming) suitable for the vehicle's vendor. We recommend using our clean and care products which are specially balanced for the vehicles. These products meet the requirements stipulated in the washing and cleaning agent directive (WRMG - Wasch- und Reinigungsmittelgesetzes).

4. Check the battery charge and recharge as necessary; refer to Section 5.4.1.



Before starting the vehicle for its first working operation, carry out an initial battery charging routine; refer to Section 2.2.

5. Check the area where the vehicle was parked for signs of leaks. Hoses, lines and tanks must show no signs of leaks or damage. If necessary, clear up any defects before putting the vehicle into operation.

## 3 Operation



Operating personnel must read the operating manual through carefully. Operating personnel should complete their initial test drive on open ground or a test track until they are familiar with the individual operating elements and the respective functions.

### 3.1 Method of operation

The Admiral 38C is a scrubber-drier designed for wet cleaning rough and structured hard floors inside buildings, such as multi-storey car parks or in logistics and industrial areas (refer to Fig. 11). It cleans floors by means of intensive scrubbing with the aid of a water and cleaning agent solution. The squeegee at the rear of the vehicle vacuums up the waste water into the recovery tank in the same working process. The Admiral 38C is a ride-on machine designed for the economic cleaning of large floor areas in buildings. A seat contact ensures that the vehicle can only be operated when an operator is seated on the driver's seat.



**Fig 11**

The most important vehicle elements are described below:

#### 3.1.1 Rotary brush head

(Fig. 12/2)

The two rotary brushes, which can be changed without the need for any tools, in the rotary brush head provide a high cleaning performance. The solution supply starts automatically when the rotary brush head is lowered. The solution is sprayed onto the floor to be cleaned by means of three nozzles. At the same time,

the contra-rotating rotary brushes start to rotate. They then scrub the floor in such a way that even dirt which has penetrated more deeply is removed. The two rotary brushes are each driven by a splashproof electric motor. The contra-rotating motion of the rotary brushes also picks up coarse dirt and throws it into the downstream waste container (sweeping function). In addition to the cleaning effect, this also ensures that coarse dirt, such as cable ties, cigarette ends etc., does not slide under the sealing strip of the squeegee and, thus, impair the vacuuming results. The waste water left over is then removed by the squeegee which follows on.

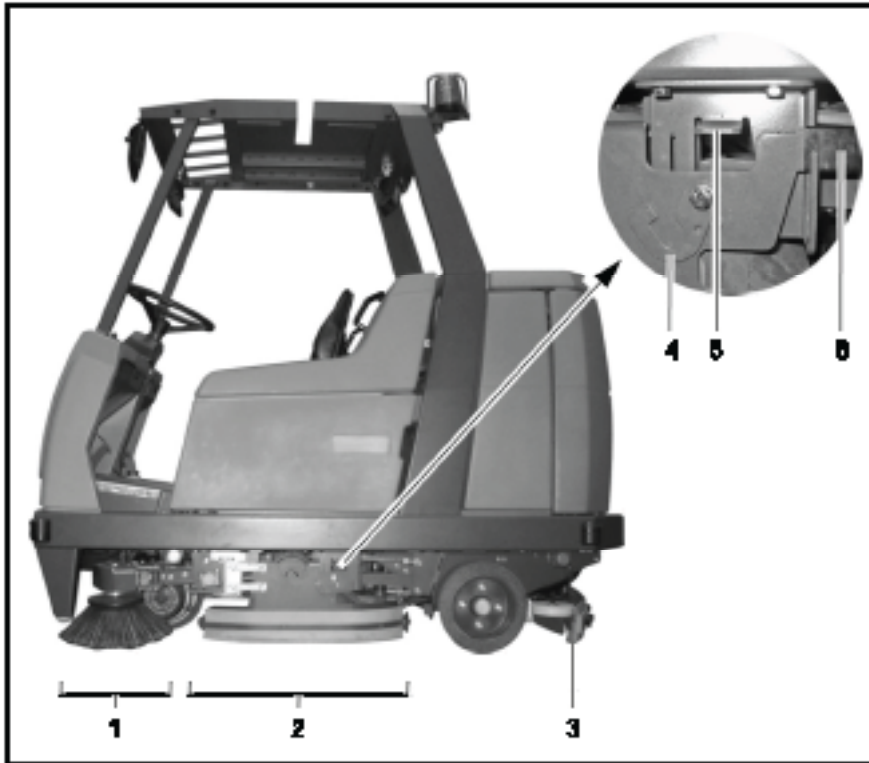

Fig 12

### Deflectors (Fig. 12/2)

To the right and left of the rotary brush head, near the floor, are two deflectors which, when in their working position, prevent water splashing to the sides and guide the waste water to the center of the vehicle so that it can be vacuumed up better.

The deflectors can be raised, if necessary. This is the case for basic cleaning, for example, where the floor only needs to be scrubbed when wet and the solution is not vacuumed up but allowed to soak in instead. To raise the deflector, take hold of the grip (Fig. 12/6), raise it and hook the locking hooks (Fig. 12/4) in the recesses in the grip above it (Fig. 12/5). Proceed in the same way on the other side of the side of the vehicle.

### Side brush unit (Fig. 12/1)

In order to be able to sweep up coarse dirt close to walls and beyond the width of the squeegee, a side brush unit, consisting of two side brushes (right and left) can be installed as an option at the front, refer to Section 3.1.9.

### 3.1.2 Squeegee

(Fig. 12/3)

The squeegee, which projects at the sides, is fixed to the Admiral 38C so that it can pivot and swing. This enables it to evade obstacles in the current cleaning track and pivot back. Its strong suction capacity ensures the waste water is vacuumed up fully even on uneven floors and in bends, leaving the floor dry enough to be walked on. The squeegee must be checked prior to starting work, when disposing of waste water and/or filling the solution tank and cleared of any foreign bodies which have been vacuumed up. Check that the sealing strips are in perfect condition. The rollers serve to support the squeegee to prevent excessive bending of the sealing strips. The squeegee is automatically raised when reversing.

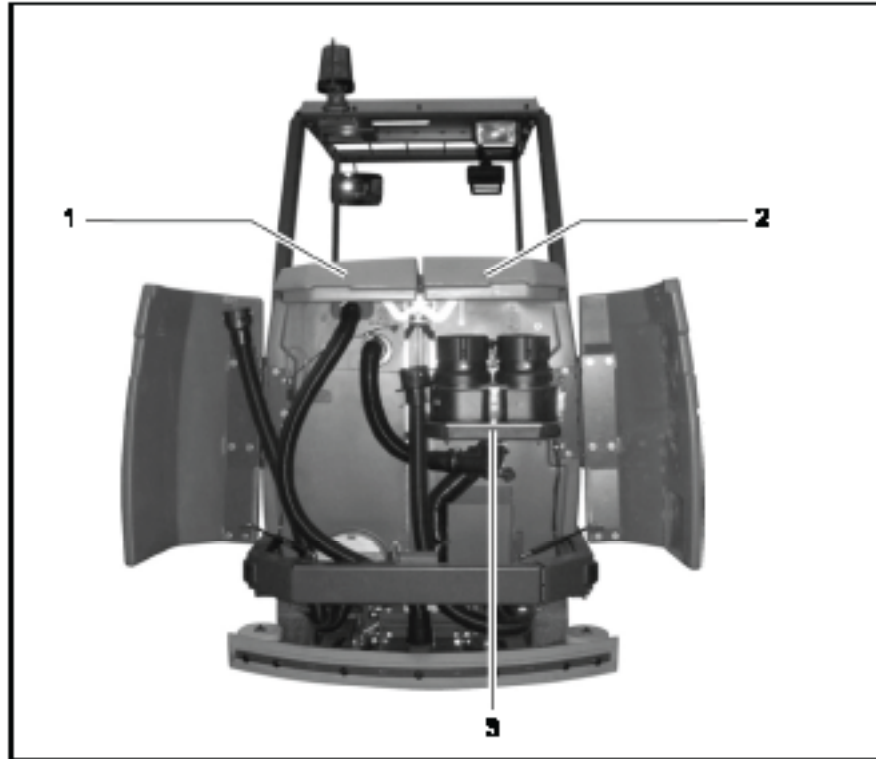

**Fig 13**



### 3.1.3 Suction turbines (suction)

(Fig. 13/3)

The two suction turbines are located on the rear panel of the solution tank and can be accessed after opening the rear doors. The suction turbines are switched on and off automatically when lowering and raising the squeegee, respectively. A float switch in the recovery tank switches the suction turbine off automatically on reaching the maximum fill height.

### 3.1.4 Solution tank

(Fig. 13/2)

The solution tank is located behind the driver's seat, on the right-hand side (when facing the front). It has a capacity of approx. 174 liters. Pivot the gray tank cap open and lock to fill. Fill water, max. 50 °C, and add the cleaning agent in accordance with the manufacturer's instructions. Pivot the tank cap back down.



Only use cleaning agents (non-foaming) suitable for the vehicle's vendor.

We recommend using our clean and care products which are specially balanced for the Admiral 38C. These products meet the requirements stipulated in the washing and cleaning agent directive (WRMG - Wasch- und Reinigungsmittelgesetzes). Observe the correct dosage of the cleaning agent. The correct dosage helps to reduce costs and protect the environment. The development of excessive foam impairs the machine's function. It indicates overdosage of the cleaning agent; components of the cleaning agent which are fed back to the waste water cause foaming. Information on dosage is provided on the cleaning agent container. Use the manufacturer's information as an initial guideline. Practical experience will ensure that you quickly find out which is the right cleaning agent and the optimum dosage to suit your needs. The solution feed to the brushes is automatically opened when the scrubbing program is activated. If necessary, the feed can be stopped manually by means of the ball cock.

Operating times with one tankful:

- at 2 l/min. approx. 87 minutes
- at 4 l/min. approx. 43 minutes
- at 7 l/min. approx. 24 minutes

### 3.1.5 Recovery tank

(Fig. 13/1)

The recovery tank is located behind the driver's seat, on the left-hand side (when facing the front). It has a capacity of approx. 174 liters. The waste water is fed to the recovery tank via the squeegee by means of a vacuum. A float switch at the top of the recovery tank switches the suction turbine off automatically as soon as the maximum tank fill level is reached. In this case, the control lamp (Fig. 15/2) on the left operating panel lights up. An acoustic signal is also issued. A vacuuming tool (refer to Section 4), which can be connected to the vehicle, is optionally available with which to clean and vacuum up water from areas difficult to access.



### 3.1.6 Traction drive

The traction drive is provided by a drive motor on the steerable front wheel. The driving speed can be continuously regulated via the accelerator by means of the electronic drive control (pulse contact control). The axle gear is a low maintenance gear train which runs in an oil bath: The gear oil need not be changed.



In the case of faults involving the traction drive, stop the vehicle immediately and remove the key from the key switch!

### 3.1.7 Brakes

The Admiral 38C is equipped with a service brake and a parking brake. The service brake relates to a drum brake which acts hydraulically on the rear wheels. It is actuated by a foot pedal. The parking brake is actuated mechanically via brake cables. It is applied by means of the foot pedal to the left of the steering column and released using the safety catch in the steering column.

### 3.1.8 Batteries and charger

The vehicle is equipped with low-maintenance batteries. The batteries concern 6 individual cells with an output of 36 Volt/320 Ah5. They are located under the seat console.

To ensure protection against total discharge, the Admiral 38C is equipped with a total discharge signal transducer (TSG). It is integrated in the electronic system and set up at the factory.



If other batteries are used, the total discharge signal transducer must be adjusted. This adjustment work should only be performed at an authorized PowerBoss service center.

The battery is provided with a connection cable with battery plug (Fig. 14/1). When the battery plug is plugged into the vehicle socket (Fig. 14/2), the vehicle is ready to operate. To charge the battery, insert the battery plug in the charger. The vehicle includes a battery charger. Pay attention to the safety information of the producer of battery and battery charger.



Fig 14

### 3.1.9 Options

The basic vehicle can be supplemented by further components. The order and spare parts numbers of these components are in brackets.

- **Cab safety roof**

(7582) (Fig. 15/2)



Purpose: To protect the driver, e.g. from objects falling from warehouse shelving. Ensure that assembly of a cab safety roof is made compulsory when the vehicle is operated in such risk areas.

- **Flashing beacon**

(7585.02 Assembly on the cab safety roof)

(7585.10 Assembly on a pole / without cab safety roof) (Fig. 15/3)

Purpose: To recognize the vehicle more clearly when in use, even in the dark.

- **Working lights**

(7584.02) (Fig. 15/1)

Purpose: To be able to use the vehicle in dark lighting conditions.

- **Side brush unit**

(7586.10) (Fig. 15/5)

Comprised of two side brushes, one for the right and one for the left side of the vehicle, which can be pivoted out.

Purpose: To enable effective cleaning along borders and sweep coarse dirt to the center of the vehicle.

- **Set of non-slip wheels**

Purpose: For safe, reliable operation of the vehicle on particularly slippery floors.

- **Spraying-vacuuming tool**

(Fig. 15/4)

Purpose: For the manual cleaning of areas difficult to access using scrubbing and vacuuming tools. A holder can be installed on the left-hand side of the vehicle to fix the vacuuming tool. Two holes are already drilled in the left-hand side of the vehicle for this. The corresponding switch is provided on the right-hand operating panel to operate the vacuuming tool.

The following belong to the spraying-vacuuming tool:

- Floor scrubbing and vacuuming tool (7009)
- Suction and spraying hose (7766)
- Tool holder and attachment parts (7311.10)

- **Hand-held vacuum cleaner**

(Fig. 15/4)

Purpose: To vacuum up water manually in areas difficult to access using the vacuuming tool. The hand-held vacuum cleaner can be fixed to the tool holder (refer to spraying-vacuuming tool). The hand-held vacuum cleaner contains:

- Adapter to connect the following tools (7893)
- Flexible plastic extension hose, length: 3 m (7880)
- Suction pipe (for connection to the plastic extension hose), length: 1.3 m (7881)
- Suction nozzle with rubber lips (7883)



With regard to accessories such as rotary brushes, suction lips etc., (Fig. 15/4) please refer to our spare parts catalog in the Internet at [www.powerboss.com](http://www.powerboss.com).

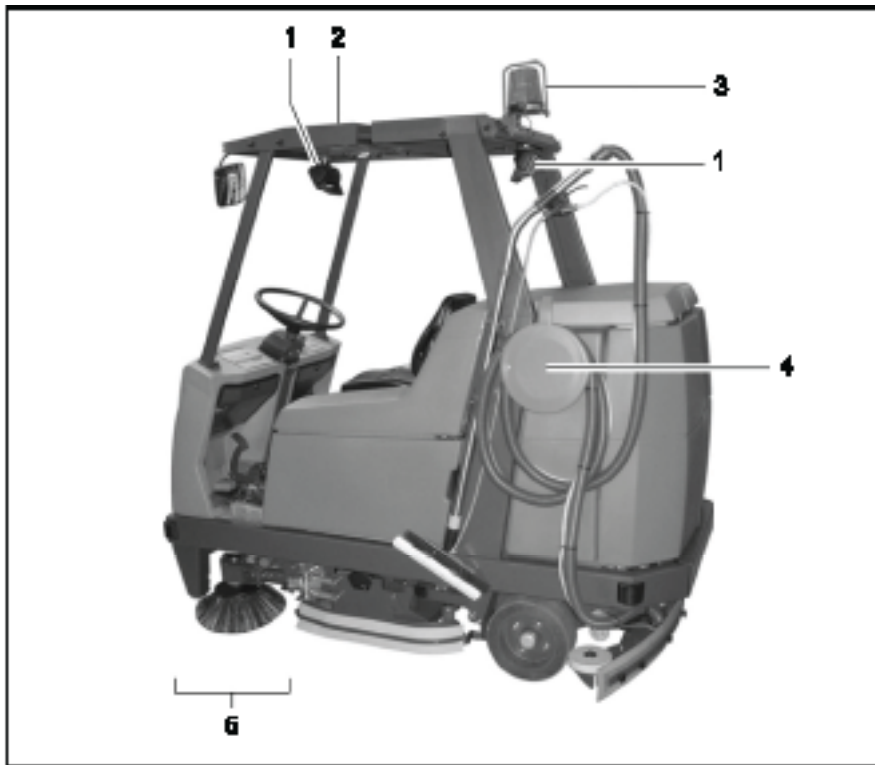

- (1) Working lights
- (2) Cab safety roof
- (3) Flashing beacon
- (4) Vacuuming tool
- (5) Side brush unit

**Fig 15**

## 3.2 Operating and indicator elements

### 3.2.1 Operating elements in the driver's cab

- (1) Left-hand operating panel
- (2) Steering wheel
- (3) Safety catch (to release the parking brake)
- (4) Accelerator to drive forwards or backwards
- (5) Service brake
- (6) Driving direction selection switch (forwards/reverse)
- (7) Right-hand operating panel
- (8) Parking brake

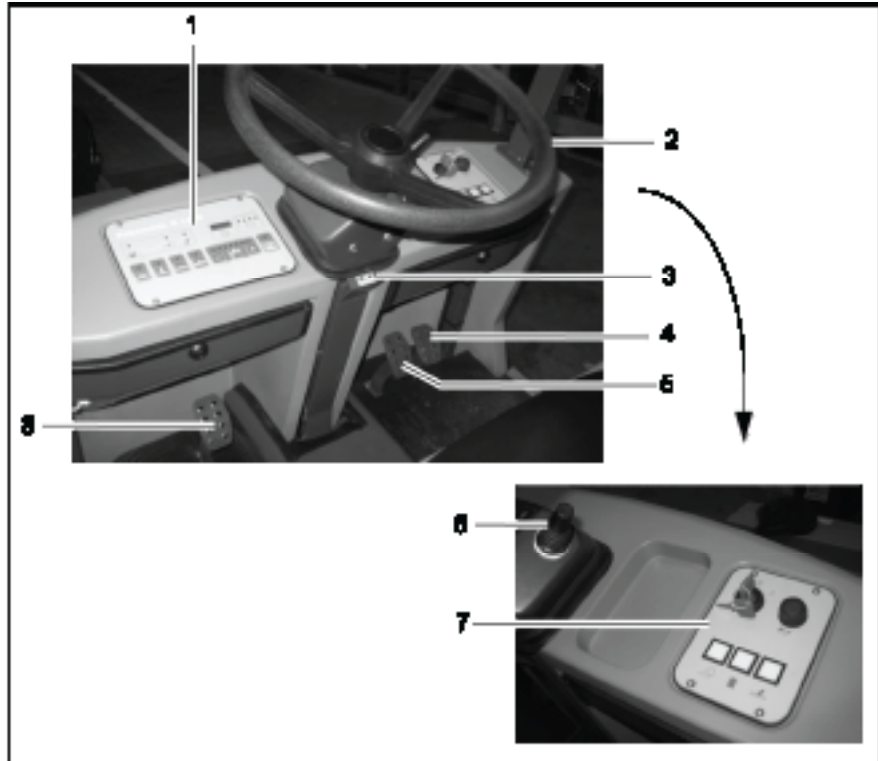

**Fig 16**

### Left-hand operating panel

(Fig. 16/1)

- This operating panel contains all the buttons for the electronically controlled standard cleaning programs.
- Individual functions can be added or removed from the cleaning process, as necessary.
- All the buttons are provided with clearly descriptive labels.
- The green control lamps in the operating buttons serve as function indicators.
- The significance and functioning method of the individual buttons on this operating panel are described in paragraph 3.2.2.

### Steering wheel

(Fig. 16/2)

- The Admiral 38C is steered by the steering wheel.

### Safety catch

(Fig. 16/3)

- The safety catch serves to release the parking brake when applied.
- Operating sequence to release brake:
  - Tread on the pedal slightly.
  - Press the catch down.
  - Release the pedal.

### Accelerator to drive forwards and backwards

(Fig. 16/4)

- The pedal on the right serves to control the driving speed (as in a normal vehicle).
- Before actuating the accelerator, use the driving direction selection switch (Fig. 16/6) to set the direction of travel: forwards or reverse.
- Forward or reverse drive (according to the driving direction selection switch setting): Tread the accelerator down, forwards, slowly.
- Release the pedal: The vehicle automatically decelerates. The vehicle rolls to a stop until reaching its zero setting.

- To stop securely, apply the service brake (Fig. 16/5).
- The speed for forward drive is approx. 8 kph and for reverse drive approx. 4 kph.
- The working speed with the brushes switched on and squeegee lowered is approx. 7.5 kph.



An acoustic warning signal (buzzer) is issued should the hydraulic motor overload. At the same time, the red alarm lamp (Fig. 16/4) lights up in the left-hand operating panel (Fig. 17/1) and the driving speed is reduced by approx. 50%. In addition, an error code appears in the service indicator (Fig. 17/5).

### Service brake

(Fig. 16/5)

- In order to slow down the vehicle and bring the Admiral 38C to a stop, tread on the foot pedal to the left of the accelerator (as with a normal vehicle) to actuate the hydraulic service brake.

### Driving direction selection switch (forwards/reverse)

(Fig. 16/6)

- It serves to select the driving direction:
  - Drive forward:  
Control lever forward
  - Reverse drive:  
Control lever back
  - Standstill:  
Control lever in center  
(neutral position)
- To change the driving direction, bring the machine to a stop by applying the service brake, select the new direction and accelerate again.

### Right-hand operating panel

(Fig. 16/7)

- This operating panel contains the key switch to switch the vehicle on and off, the horn and three switches for the optionally available working lights, spraying/vacuumping tool and flashing beacon; also refer to paragraph 3.2.3.

### Parking brake

(Fig. 16/8)

- The pedal to the left of the steering column serves to apply the parking brake to the rear wheels.
- When the parking brake is applied, the corresponding control lamp on the operating panel (Fig. 17/3) lights up red.
- If the driving direction selection switch is actuated while the parking brake is applied, a pulsating “beep” is issued.



Before getting out of the vehicle apply the parking brake, set the driving direction selection switch (Fig. 16/6) to its neutral position and switch the key switch to off.

### 3.2.2 Left-hand operating panel

(Fig. 2)

- (1) Indicator field
- (2) Recovery tank indicator: When the control lamp is on (yellow), the maximum fill level has been reached.
- (3) Indicator for parking brake: When the control lamp is on (red), the parking brake is applied.
- (4) Indicator for error message: When the control lamp is on (red), a functional fault has occurred.
- (5) Operating hours counter and service indicator
- (6) Battery and charge control indicator
- (7) Button for side brush unit (option)
- (8) Button for brush pressure
- (9) Button for brush drive
- (10) Button for squeegee and suction turbine
- (11) Buttons for controlling the solution supply
- (12) Button to reduce solution quantity
- (13) Button to switch solution supply on and off
- (14) Button to increase solution quantity
- (15) Green PowerBoss button for simultaneous activation of scrubbing unit and vacuuming function

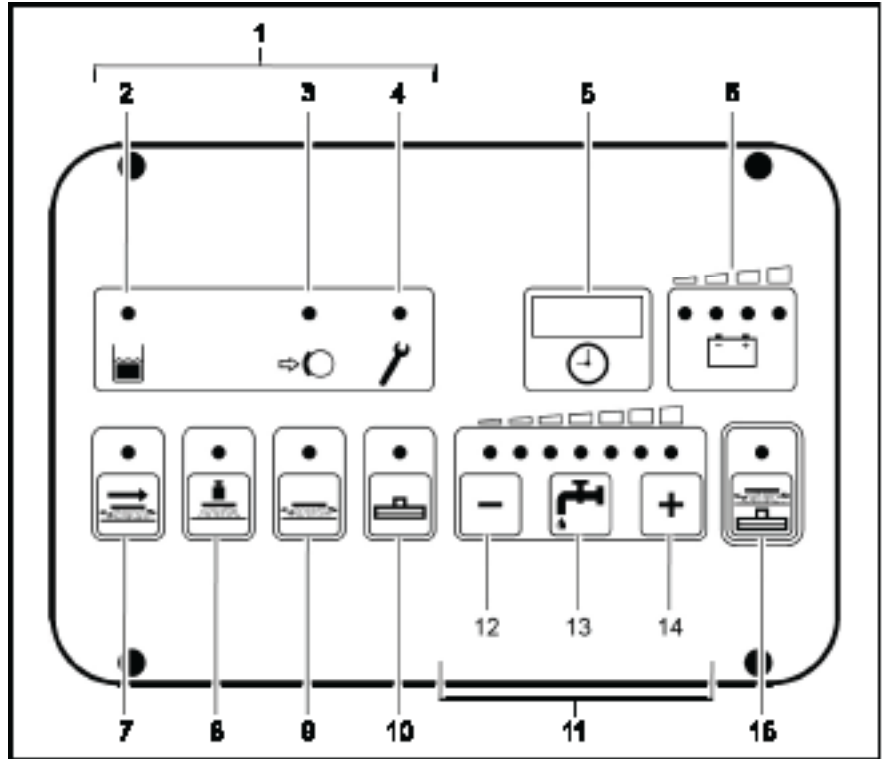

Fig 17



## Indicator field

(Fig. 17/1) The indicator field enables the Admiral 38C to provide feedback on the operating status of the vehicle. This only relates to operating states which cannot be switched on or off via the operating panel: recovery tank full, parking brake applied and error messages.

The individual buttons and functions are described in detail below:



### Indicator for recovery tank maximum fill level

(Fig. 17/2) The yellow control lamp lights up when the recovery tank has reached its maximum fill level. Also, a “beep” signal is issued every 15 seconds. In this case, a float switch switches the suction turbine off and the squeegee is raised.



### Indicator for parking brake applied

(Fig. 17/3) The control lamp lights up red when the parking brake has been actuated via the pedal to the left of the steering column. If the traction drive

is switched on, an acoustic signal is also issued.



### Indicator for function faults

(Fig. 17/4)

The control lamp lights up red when one of the following faults occurs:

- The thermostatic switch disconnects from the brush or hydraulic motor.
- One of the safety fuses is defective or an electronic fuse has been tripped.
- Another fault has occurred.

At the same time, a four-digit code appears in the display of the service indicator (Fig. 17/5). This error code infers which fault has occurred (refer to Section 3.5.1). At the same time, the control lamps flash and an acoustic, pulsating signal is issued.

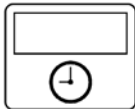

### Operating hours counter

(Fig. 17/5) The four-digit LED serves to display the operating hours. When the

key in the key switch is turned on, one and then two four-digit codes appear in succession (for further details, refer to Page 36, Key Switch (Fig. 18/1)). The operating

hours appear after this.

The counter only operates when consumers are switched on (e.g. hydraulic or brush motor, suction turbine). At the same time, a red dot flashes at the bottom right of the display.

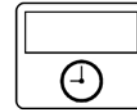

### Service indicator

(Fig. 17/5) The same LED also serves for a more accurate determination of function faults. If a fault

occurs during operation, a four-digit code (error code) appears in the service indicator display. At the same time, the four dots of the error code flash in the display and a pulsating acoustic signal is issued. The control lamp in the functional fault display lights up red. Section 3.5 provides an overview of the error codes which help you clear functional faults yourself. Clear the fault before starting to use the vehicle again. If you cannot clear the fault yourself, note down the error code and inform the authorized PowerBoss dealer responsible for your vehicle.

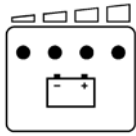

### Battery and charge control indicator

(Fig. 17/6) After switching on the key switch, all four lamps light up when the battery is fully charged. As the battery is discharged during operation, the three right-hand lamps indicate the level of discharge by going out in sequence from right to left. When the left, red lamp flashes, it indicates that work must come to an end. Approximately three minutes later, the brushes will return to their home position. After a further three minutes, the suction turbines are deactivated and the squeegee is raised. When the red lamp lights up continuously, approximately one minute remains until the entire vehicle shuts down automatically.



Drive back to the charger in good time. Take the distance to the charger into account.



### Button for side brush unit

(Fig. 17/7) This button is used to activate the side brush unit. After pressing the button, the

two brushes start or stop rotating and the brush is lowered or raised accordingly. If the side brush unit is switched on, the green control lamp lights up.

The side brush unit is an optional accessory. If it is not installed, the button has no function.



The side brush unit can only be switched on when the rotary brushes are also switched on.



### Button for brush pressure

(Fig. 17/8) This button is used to increase the brush pressure. This may be necessary when the area to be cleaned is extremely dirty. The pressing force can be increased to max. 104 lb. If the function is active, the green control lamp lights up.



Working with an increased brush pressure also means increased brush wear. Therefore, only press this button when necessary.



### Button for rotary brush drive

(Fig. 17/9) This button serves to switch the rotary brushes and solution feed on and off with simultaneous, respective lowering or raising of the brush head. If the function is active, the green control lamp lights up.



### Button for squeegee and suction turbine

(Fig. 17/10) This button serves to switch the suction turbine on and off with simultaneous lowering and raising of the squeegee. If the function is active, the green control lamp lights up.



This button must also be pressed when working with optional tools connected to a suction hose. Operating personnel must not be seated on the driver's seat in this case (seat contact is bypassed). Only the suction turbine is activated at this point, the squeegee remains raised.

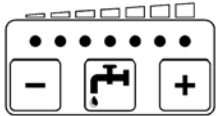

### Buttons controlling the solution supply

(Fig. 17/11) The solution consumption used during cleaning

can be regulated in seven stages. Accordingly, there are seven green control lamps on the keypad. Each lamp relates to one stage. The maximum quantity which can be used for cleaning is 5.5 l/min (all seven lamps are on). The minimum quantity is 1.25 l/min (only the left lamp is on). The last solution quantity selected is always used. When the scrubbing program is switched on for the first time, a solution quantity of approx. 3.5 l/min is automatically set.



### Button to reduce solution quantity

(Fig. 17/12) The button serves to reduce the solution quantity

supplied to the brushes. The solution quantity can be reduced in seven stages (see above). The selected stage remains programmed (last station memory) even if the vehicle is switched off temporarily.



### Button to switch the solution supply on and off

(Fig. 17/13) This button serves to switch the solution feed on and off

when the brush head is lowered. The solution quantity previously set remains unaltered (last station memory).



### Button to increase solution quantity

(Fig. 17/14) This button serves to increase the solution quantity

supplied to the brushes. The solution quantity can be increased in seven stages (see above). The selected stage remains programmed (last station memory) even if the vehicle is switched off temporarily.



### Green PowerBoss button for simultaneous activation of scrubbing unit and vacuuming function

(Fig. 17/15) After pressing the green PowerBoss button, the most important basic functions for standard cleaning are switched on and off automatically in the correct sequence for the respective

technical application: suction turbines, brush rotation, solution feed and lowering or raising of the brushes and squeegee. When the vehicle is ready for use in accordance with requirements, it can be set into operation simply and quickly by pressing the PowerBoss button. When the PowerBoss button has been pressed, the green control lamp lights up.

### 3.2.3 Right-hand operating panel

(Fig. 3)

- (1) Key switch
- (2) Horn
- (3) Switch for spraying/vacuuming tool
- (4) Switch for flashing beacon
- (5) Switch for working lights

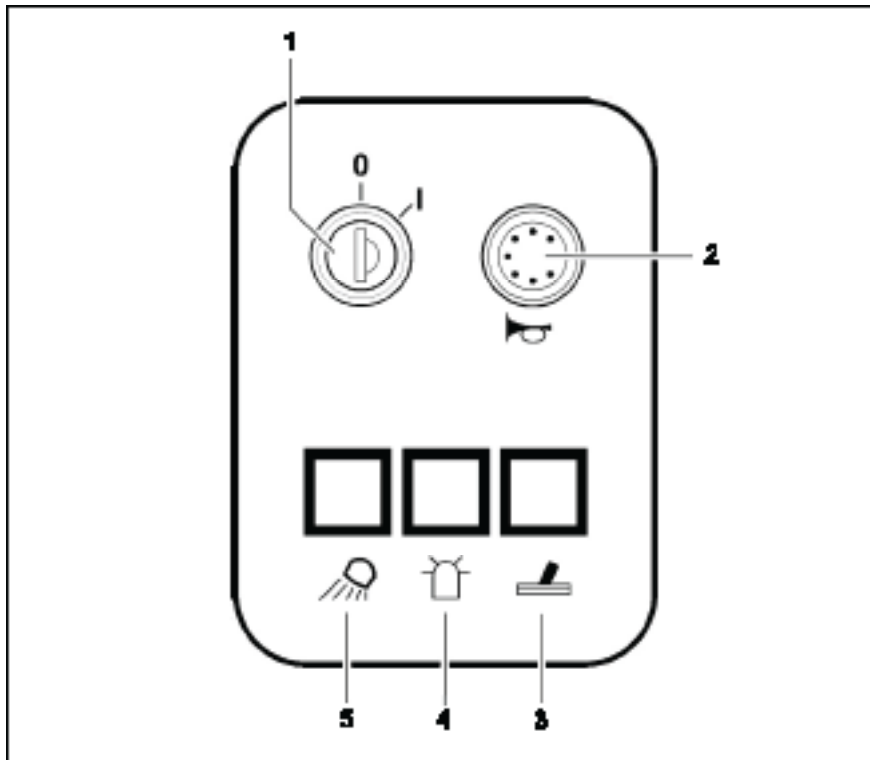
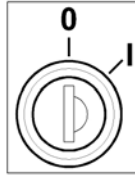

Fig 18

## Key switch

(Fig. 18/1)

It serves to switch the electrical installations on and off and to secure the vehicle against unauthorized use.



When the key switch is switched on (lock position 1), the following appear in the operating hour counter display (lefthand operating panel, refer to Paragraph “Operating hours counter” in paragraph 3.2.2):

## 1 Software version

Displayed for approx. 1 second.

Example:

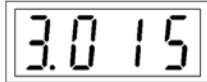

## 2 Error code

Indicates the last fault which occurred, displayed for approx. 2 seconds.

The display serves as information for the service technician so that the fault can be cleared quickly. For an overview of the error codes, refer to Section 3.5.1.

Example:

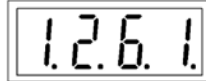

When a functional fault actually occurs, an acoustic signal is also issued and the red control lamp on the alarm indicator (Fig. 17/4) lights up.

## 3 Operating hour indicator

Continual display.

Example:

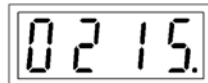

During operation, the dots flash in the display.

## 4 Control digits (optional)

In the case of brand new vehicles, it is possible that after switching on the key switch, the following display also appears:



The control digits are for internal control purposes. The display changes to zero operating hours after one hour at the latest. The Admiral 38C is ready for use while this display appears. The alarm indicator is activated.

## Horn

(Fig. 18/2)

An acoustic warning signal is issued on actuating the horn knob.

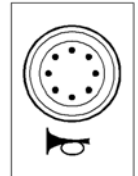

**Switch for spraying/  
vacuuming tool**

(Fig. 18/3)

This switch switches the vacuuming tool on or off. The suction tool is an optional accessory. If it is not installed, the switch has no function.



**Switch for flashing  
beacon**

(Fig. 18/4)

The flashing beacon is an optional accessory. If no flashing beacon is installed, the switch has no function.

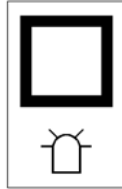

**Switch for working lights**

(Fig. 18/5)

This switch switches the working lights on or off. This occurs even without the key switch being turned on.

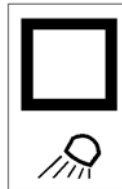

The working lights are optional accessories. If no working lights are installed, the switch has no function.

### 3.2.4 Operating elements on the vehicle

- (1) Waste water filter
- (2) Solution tank filling neck
- (3) Lid lock
- (4) Cover, solution tank
- (5) Cover, recovery tank
- (6) Waste water draining hose
- (7) Solution draining hose
- (8) Left-hand rear door
- (9) Rear panel frame lock
- (10) Rear panel frame
- (11) Right-hand rear door

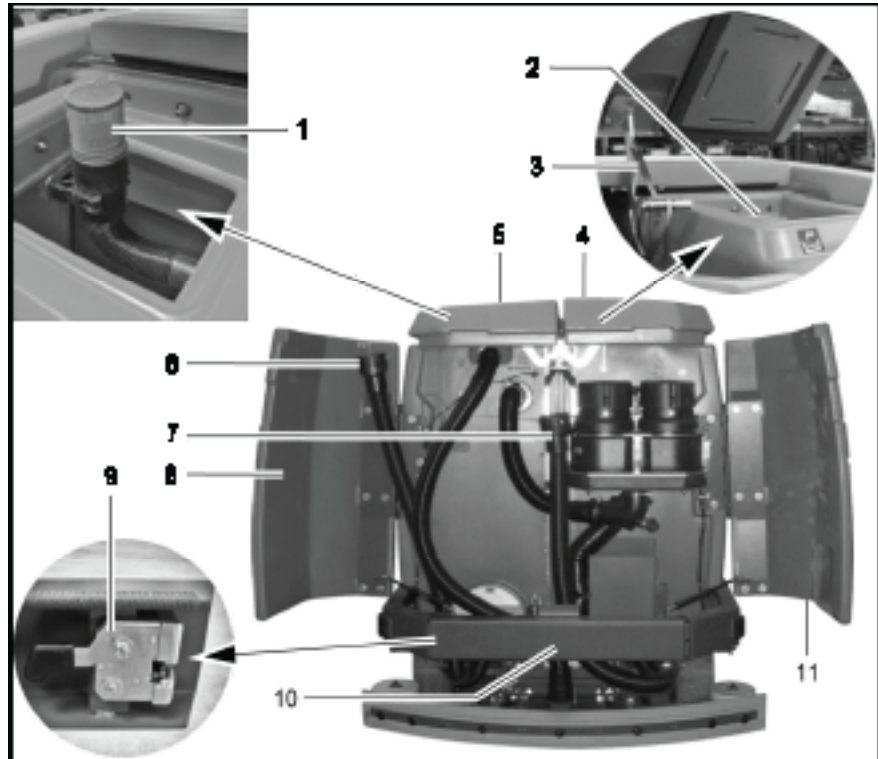

**Fig 19**

### **Recovery tank**

(Fig. 19/1+5)

The waste water filter (Fig. 19/1) is located under the recovery tank lid (Fig. 19/5) at the top of the recovery tank and is connected to the end of the suction pipe. It filters large particle dirt from the waste water and must be inspected or cleaned daily, refer to Section 5.6.4.

### **Solution tank**

(Fig. 19/2+4)

In order to fill fresh water and cleaning agent, pivot up the lid of the solution tank (Fig. 19/4) and lock it. The tank is filled through the filling neck (Fig. 19/2) at the top, refer to Section 5.5.1.

### **Lid lock**

(Fig. 19/3)

The lock prevents the lid falling shut. To lock the lid, move the bar and latch in place. The lid lock functions in the same way on the solution tank and recovery tank.

### **Rear doors**

(Fig. 19/8+11)

Open the rear doors to access the draining hoses for waste water and solution.

### **Waste water draining hose**

(Fig. 19/6)

The draining hose for waste water hooked is in the left-hand rear door. Only drain off waste water through this hose at an appropriate location, refer to Section 5.6.1.

### **Solution draining hose**

(Fig. 19/7)

The draining hose for solution hangs to the left of the suction turbines. Only drain off the solution through this hose at an appropriate location, refer to Section 5.5.2.

### **Rear panel frame**

(Fig. 19/9+10)

In order, for example, to access the flap to clean the recovery tank, the rear panel frame doors must be opened. To do this, pull the lock lever (Fig. 19/9) up and open the unlocked rear panel frame doors (Fig. 19/10).



- (12) Seat console
- (13) Electrical compartments
- (14) Side door
- (15) Battery trough



**Fig 20**

### **Seat console**

(Fig. 20/12)

The driver's seat is mounted on the seat console. The seat console can be pivoted up using the handle in order to access the batteries and electric system.

### **Electrical compartments**

(Fig. 20/13)

In the driver's cab, to the left and right of the steering column, are two electrical compartments which must be opened by means of a special square wrench.



The electrical compartments are not provided in the sense of glove compartments.

### **Side door**

(Fig. 20/14)

The side doors are located to the left and right of the trough battery. The doors must be pivoted open in order to change the battery trough, refer to Sections 5.4.3 and 5.4.4.

### **Battery trough**

(Fig. 20/15)

The battery trough contains the 18 individual battery cells and serves to enable a quick change of battery. The battery trough is provided with fitting holes in order to be able to change it using suitable tools, also refer to Sections 5.4.3 and 5.4.4.

### 3.3 Operation

The Admiral 38C can be driven for a maximum of 5 minutes on surfaces which have a gradient in excess of 6%.



Adapt your driving style to the local conditions (floor characteristics, persons in the vicinity, obstacles etc.).

#### 3.3.1 Switching the vehicle on



Please read Section 1 before switching the vehicle on.

Carry out the following steps so that the vehicle is ready to operate:

- Disconnect the battery plug from the charger and connect it to the vehicle.



When connecting the battery plug to the vehicle, switch the key switch to off (lock position 0) beforehand.

- The vehicle is equipped with a safety shutdown via a seat contact (dead

man's switch). This means that it is essential for operating personnel to be seated in the driver's seat to be able to operate the vehicle.

- Ensure that the driving direction selection switch is in its zero setting, refer to accelerator for driving forwards and backwards in Section 3.2.1.

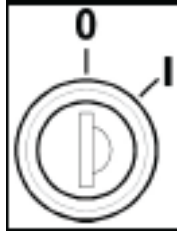

Fig 21

- Actuate the service brake with your foot in order to prevent accidentally accelerating the vehicle, refer to Service Brake in Section 3.2.1.
- Insert the key in the key switch (Fig. 21).
- Turn the key from lock position 0 to position 1.  
The vehicle is ready to operate.

#### 3.3.2 Accelerating

- Use the direction switch to select the required driving direction: Move the switch forwards for forward drive, move the switch back for reverse drive.
- Release the parking brake, refer to Safety Catch in Section 3.2.1.
- Press the accelerator down slowly with your right foot until you reach the required driving speed.

### 3.3.3 Stopping and parking

- Remove your right foot from the accelerator to slow down. When the foot is fully removed from the accelerator, the vehicle rolls to a stop.
- Now press the right foot on the service brake pedal to stop the vehicle and bring it to a stop.
- Turn the key in the key switch counter-clockwise to lock position 0 and remove the key.
- Press the left foot on the parking brake pedal to park the vehicle.



Always apply the parking brake and remove the key before getting out of the vehicle!

### 3.3.4 Cleaning

There are four cleaning programs available for selection:

1. Wet scrubbing and vacuuming dry
2. Wet scrubbing (basic cleaning)
3. Vacuuming dry
4. Vacuuming with the hand-held suction hose (option)

The cleaning programs are activated via the left-hand operating panel, refer to Sections 3.2.2. Press the required button as soon as the Admiral 38C is ready to drive (see above).

#### Wet scrubbing and vacuuming dry

This program is the standard cleaning program for this vehicle.

- Press the green PowerBoss button on the left-hand operating panel.



Various functions can be switched on or off with the following buttons according to the conditions at the location of use:

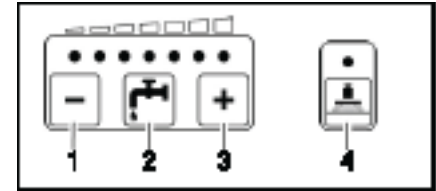

Fig 22

- Reduce solution quantity (Fig. 22/1)
- Increase solution quantity (Fig. 22/3)
- Solution on/off (Fig. 22/2)
- Increase brush pressure (Fig. 22/4)



Check whether the floor is sufficiently dry at regular intervals, otherwise people could slip. If the floor is excessively wet, check the vehicle for leaks and that the sealing strips are in a good condition. If the sealing strips are damaged, change them; refer to Section 5.8.4.

## Wet scrubbing (basic cleaning)

If you do not want to vacuum the floor dry in the same working procedure because you want the solution to soak into the dirt, for example, activate this program.



Wet floors are a potential risk for slipping! Ensure to provide the corresponding information and warning signs.

- Press the “Button for rotary brush drive” button (Fig. 15/9) on the left-hand operating panel.

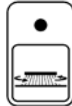

Various functions can be switched on or off with the following buttons according to the conditions at the location of use:

- Reduce solution quantity (Fig. 22/1)
- Increase solution quantity (Fig. 22/3)
- Solution on/off (Fig. 22/2)
- Increase brush pressure (Fig. 22/4)

## Vacuuming dry

- Press the “Button for squeegee and suction turbine” on the left-hand operating panel.



Check whether the floor is sufficiently dry at regular intervals, otherwise people could slip. If the floor is excessively wet, check the vehicle for leaks and that the sealing strips are in a good condition. If the sealing strips are damaged, change them; refer to Section 5.8.4.

## Vacuuming with the hand-held suction hose

The hand-held suction hose is an optional accessory.

Vacuuming with the hand-held suction hose only works when the operator is not seated on the driver’s seat (seat contact switch is not actuated).



Always apply the parking brake before getting out of the vehicle!

- Press the “Button for squeegee and suction turbine” on the left-hand operating panel.

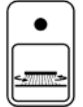

The squeegee remains raised.

## Useful tips for cleaning

- Sweep the floor before starting wet cleaning. This not only improves the cleaning effect but also reduces the vehicle’s liability to wear.
- The floor should be treated twice in the case of particularly dirty floors or to remove wax (basic cleaning).
  - During the first cleaning process, the floor is scrubbed with a cleaning agent dosage appropriate to the degree of soiling, whereby the squeegee is raised.
  - Let the cleaning solution work into the floor for 5 to 10 minutes according to the manufacturer’s information.
  - Then scrub the floor again with the squeegee lowered.
- Observe the correct dosage of the cleaning agent. Information on dosage is provided on the cleaning agent container.
- Use the manufacturer’s information

as an initial basis. Practical experience will ensure that you quickly find out which is the right PowerBoss cleaning agent and the optimum dosage to suit your needs.



The correct dosage helps to reduce costs and protect the environment.



The development of excessive foam impairs the machine's function.

- Cause: Too much cleaning agent leads to certain component parts of it getting into the waste water resulting in the development of foam. This indicates that the amount and mixture of solution do not match the level of dirt.

### 3.3.5 Switching the vehicle off

- Turn the key from lock position 1 to position 0. The vehicle is no longer ready to operate.
- Remove the key from the key switch.



Apply the parking brake!

### 3.3.6 Loading and transporting the vehicle

Refer to Section 5.12.

### 3.4 After finishing work

1. Drive to a suitable service or parking area.



An appropriate service and parking area must have a solid floor, have a roof and ensure that no hazardous substances (e.g. oils, battery acid, cleaning agents, etc.) can get onto the floor or in the sewage system.

2. Stop the vehicle and switch it off.



Before getting out of the vehicle apply the parking brake, switch off the key switch and remove the key.

3. Empty and clean the waste container, refer to Section 5.7.1.
4. Empty the recovery tank and rinse it out, refer to Sections 5.6.1 and 5.6.2.



Observe the applicable laws and local regulations when disposing of cleaning agents.

5. Check the solution filter, refer to Section 5.5.4.

6. Check the sealing strips and suction hose, refer to Section 5.8.
7. Check the electrical equipment, functions and settings.
8. Clean the vehicle, refer to Section 5.11.



It is not permitted to clean the vehicle with a pressure washer or steam blaster.

9. Charge the batteries, refer to Section 5.4.1.



The seat console must remain open during the charging process (otherwise there is a risk of oxygen developing).



If the vehicle is to be shutdown for a longer period, the solution tank must be emptied.

**3.5 Function faults**



The following applies when locating the cause of functional faults and clearing them:  
Switch the vehicle off, remove the key and disconnect the battery plug!

**3.5.1 Error code table**

In the case of system errors, a four-digit error code appears in the left-hand operating panel in addition to the service indicator (wrench symbol).

The dots in the error/service code flash. Clear the fault or note down the error/service code and inform your authorized PowerBoss dealer.

Error code	Fault	Cause	Solution
1.2.5.2.	The brushes remain stopped because the thermostatic switch has been tripped.	The motor has overheated; foreign bodies have possibly jammed between the brush and shaft (e.g. tape and such).	<ul style="list-style-type: none"> <li>• Check the brushes for foreign bodies and remove them, as necessary.</li> <li>• Allow the motor to cool down.</li> <li>• If the problem reoccurs, determine the cause of overheating; contact an authorized PowerBoss service center, if necessary.</li> </ul>
1.2.6.1.	The brushes remain stopped because the anti-blocking system has been tripped.	Foreign bodies (e.g. tape or such) block the brushes	<ul style="list-style-type: none"> <li>• Check the brushes for foreign bodies and remove them, as necessary.</li> </ul>
1.2.6.1.	The rotary brush holding attachment and brush motors have been switched off because the anti-blocking system has been tripped	Foreign bodies between the brush head and vehicle.	<ul style="list-style-type: none"> <li>• Check the brush head for foreign bodies and remove them, as necessary.</li> </ul>



Error code	Fault	Cause	Solution
2.3.5.1	The side brushes remain stopped because the thermostatic switch has been tripped.	The motor has overheated. Foreign bodies have possibly jammed between the side brushes and shaft (e.g. tape and such).	<ul style="list-style-type: none"> <li>• Check the side brushes for foreign bodies and remove them, as necessary.</li> <li>• Allow the motor to cool down.</li> <li>• If the problem reoccurs, determine the cause of overheating; contact an authorized PowerBoss service center, if necessary.</li> </ul>
2.3.6.1.	The side brushes remain stopped because the anti-blocking system has been tripped.	Foreign bodies (e.g. tape or such) are blocking the side brushes	<ul style="list-style-type: none"> <li>• Check the side brushes for foreign bodies and remove them, as necessary.</li> </ul>
2.3.6.4.	The side brush holding attachment has been switched off because the anti-blocking system has been tripped.	Foreign bodies between the side brush unit and vehicle	<ul style="list-style-type: none"> <li>• Check the side brush unit for foreign bodies and remove them, as necessary.</li> </ul>
1.4.6.1.	The squeegee holding attachment has been switched off because the anti-blocking system has been tripped.	<ul style="list-style-type: none"> <li>• Foreign bodies between the squeegee and vehicle.</li> <li>• Squeegee is jammed</li> </ul>	<ul style="list-style-type: none"> <li>• Check the holding attachment for foreign bodies and remove them, as necessary.</li> <li>• Free the squeegee.</li> </ul>

**Table 1**

### 3.5.2 Other function faults

The vehicle does not work  
 Check the fuses, refer to Section 5.10.3.



In the event of faults in the traction drive, stop the vehicle immediately, apply the parking brake and remove the key!

**4 Technical Data**

<b>Dimensions</b>		
Vehicle length (with brush head and squeegee)	in	84.7
Vehicle height, without/with cab safety roof	in	55.1/78.7
Vehicle width, without/with squeegee	in	44.5/49.6
Vehicle width with side brush unit (option)	in	53.5
<b>Working width</b>		
Brush head	in	37.4
Squeegee	in	49.6
With side brush unit (option)	in	53.5
<b>Area coverage</b>		
Theoretical at 7.5 kph	ft <sup>2</sup> /h	76693
<b>Weights</b>		
Dead weight (without driving batteries, without options, without driver)	lbs	1561
Total weight, operational, wet (with cab safety roof and side brush unit, without driver)	lbs	2919
Gross total weight	lbs	3631
Transport weight including driving batteries, without options, without solution, without driver	lbs	2372
<b>Axle loads</b>		
Ready to use, front	lbs	1303
Ready to use, rear	lbs	1616

## Technical Data

<b>Driving performance</b>		
Driving speed, forwards/reverse	kph	5.0/2.5
Working speed, maximum, forwards	kph	4.7
Climbing capacity, driving mode (max. 1 min)	%	15
Climbing capacity, work mode (max. 5 min)	%	6
Turning circle diameter, outer	m	3.35
Lock in aisle: minimum width of aisle	m	2.40
Operating time with one battery charge	h	Approx. 3.8
<b>Traction drive</b>		
Drive motor (P2)	W	1400
<b>Axles and wheels</b>		
Wheelbase	in	45.3
Gauge, rear	in	34.7
Front wheel, diameter/width	in	11.8/3.9
Rear wheel, diameter/width	in	12.2/4.7
Specific wheel pressure at permissible gross total weight, front/rear	ksi	0.186/0.135
Tightening torque of wheel nuts on rear wheels	lb ft	103.3

<b>Brakes</b>		
Service brake:		Hydraulic
Rear drum brake, with automatic adjustment: diameter/width	in	7.1/1.6
Brake fluid (e.g. ATE)	gallon	0.1
Parking brake:		
Rear cable brake, adjustable: diameter/width	in	7.1/1.6
<b>Tank volume</b>		
Fixed panel tank: solution / waste water	gallon	46.0/46.0
Flow rate, adjustable from/to	gallon/min.	0.3/1.5
<b>Rotary brush head</b>		
No. of rotary brushes	Pieces	2
Rotary brush diameter	in	5.4
Rotary brush speed	rpm	900
Brush pressure, min./max.	lb	79/104
Specific contact pressure, min./max. (with brush PA6 0.7)	psi	0.73/0.87
<b>Suction turbines</b>		
Power consumption/speed	W/rpm	635/13867
Air flow rate	ft <sup>3</sup> /h	8476
Vacuum	psi (mmwc)	2.94 (2030)

## Technical Data

<b>Electrical installation</b>		
Power supply	VDC	36
Type of current		DC
Nominal power, total	W	5500
Protection class	VDE 0700	III
Battery compartment: length/width/height	in	37.4/24.0/18.3
<b>Noise emission value</b>		
The sound power level (LWAd) measured according to EN 60335-2-72 under normal under working conditions is:	dB (A)	90
The sound pressure level (LpA) measured according to DIN EN 60335-2-72 (at the driver's ear) under normal working conditions is:	dB (A)	76.5
Inaccuracy factor (KpA):	dB (A)	2
<b>Vibration</b>		
The weighted, effective value of the vibration, established in accordance with ISO 5349-1 to which the upper limbs (hand-arm) are exposed under normal working conditions is:	m/s <sup>2</sup>	< 2.5
The weighted, effective value of the vibration and shock, established in accordance with ISO 2631-1, to which the body (feet and seat area) are exposed under normal working conditions is:	m/s <sup>2</sup>	< 0.5

<b>Special equipment:</b>		
<b>Driving batteries</b> block battery	Order number V/Ah5	4202 6x6/320 (CR395)
<b>Cab safety roof (including rear-view mirror)</b>	Order number	7582
<b>Working lights, 2 pieces</b>	Order number V/W	7584.02 2 x 24/70
<b>Flashing beacon</b> For installation on the cab safety roof For installation on a pole (when no cab safety roof is available)	V Order number Order number	36 7585.02 7585.10
<b>Side brush unit</b> Brush speed Brush motor: power consumption/speed	Order number rpm W/rpm	7586.10 80 70/3000
<b>Rotary brushes</b> Plastic PA 0.7 for light to medium accumulations of dirt SIC PA 6.12 grain 500 for medium to heavy accumulations of dirt SIC PA 6.12 grain 180 for heavy to extreme accumulations of dirt SIC PA 6.12 grain 80 for extreme accumulations of dirt SIC PA 6.12 grain 46 for extreme accumulations of dirt	Order number Order number Order number Order number Order number	7887 7846 7890 7848 7847

## Technical Data

<b>Additional scrubbing and vacuuming tools (spraying-vacuuming tool)</b>		
Floor scrubbing and vacuuming tool	Order number	7009
Vacuuming and spraying hose (length: 5 m)	Order number	7766
Tool holder and attachment part	Order number	7311.10
<b>Additional tools for using the suction hose (hand-held vacuum cleaner)</b>		
Adapter to connect the following tools	Order number	7893
Suction hose (length: 3 m)	Order number	7880
Suction pipe (length: 1.3 m)	Order number	7881
Suction nozzle with rubber lips	Order number	7883

## 5 Maintenance and Service

### General information



It is essential to pay attention to the information in Chapter “Safety Information” before completing any service or maintenance work!

By adhering to the maintenance work recommended by us, you can be sure that the vehicle is always ready to be put into operation.

Maintenance and repair work necessary on a daily and weekly basis can be carried out by a driver trained to complete the work, all other PowerBoss system maintenance may only be completed by personnel who are correspondingly qualified and trained. In case of doubt, please contact your nearest PowerBoss service center or authorized PowerBoss dealer. Failure to observe this annuls any rights to claims under the terms of warranty in respect of resulting damage or consequential damage.

Always specify the serial number, indicated on the rating plate, when making any inquiries and orders for spare parts, refer to Section 1.7.

### 5.1 PowerBoss system maintenance

PowerBoss system maintenance:

- ensures the PowerBoss working vehicle is always ready for operation (preventive maintenance),
- minimizes operating costs, maintenance and repair costs,
- ensures the vehicle has a long service life.

PowerBoss system maintenance describes the specific technical work necessary for the individual modules and defines the intervals for the maintenance tasks. Individual parts which must be changed during maintenance tasks are defined and stipulated in spare parts kits.

#### **PowerBoss system maintenance, customer:**

Work to be carried out by the customer according to the service and maintenance instructions in the operating manual (daily and weekly). Operating personnel are given the necessary instruction by specialists when the vehicle is delivered.

#### **PowerBoss system maintenance I:**

(Every 250 operating hours)

Must be completed by a skilled technician in an authorized PowerBoss service center according to the vehiclespecific system maintenance with a spare parts kit.

#### **PowerBoss system maintenance II:**

(Every 500 operating hours)

Must be completed by a skilled technician in an authorized PowerBoss service center according to the vehiclespecific system maintenance with a spare parts kit.

#### **PowerBoss system maintenance III/S:**

(Every 1000 operating hours safety check)

Must be completed by a skilled technician in an authorized PowerBoss service center according to the vehiclespecific system maintenance with a spare parts kit.



## 5.2 Maintenance report

<p style="text-align: center;"><b>Handover</b></p> <p>Upgrading Test drive Handover to customer Instruction completed on: at _____ operating hours</p>	<p style="text-align: center;"><b>PowerBoss System Maintenance I 250 operating hours</b></p> <p style="text-align: center;">Workshop Stamp</p> <p>completed on: at _____ operating hours</p>	<p style="text-align: center;"><b>PowerBoss System Maintenance II 500 operating hours</b></p> <p style="text-align: center;">Workshop Stamp</p> <p>completed on: at _____ operating hours</p>	<p style="text-align: center;"><b>PowerBoss System Maintenance II 750 operating hours</b></p> <p style="text-align: center;">Workshop Stamp</p> <p>completed on: at _____ operating hours</p>
<p style="text-align: center;"><b>PowerBoss System Maintenance III/S 1000 operating hours</b></p> <p style="text-align: center;">Workshop Stamp</p> <p>completed on: at _____ operating hours</p>	<p style="text-align: center;"><b>PowerBoss System Maintenance I 1250 operating hours</b></p> <p style="text-align: center;">Workshop Stamp</p> <p>completed on: at _____ operating hours</p>	<p style="text-align: center;"><b>PowerBoss System Maintenance II 1500 operating hours</b></p> <p style="text-align: center;">Workshop Stamp</p> <p>completed on: at _____ operating hours</p>	<p style="text-align: center;"><b>PowerBoss System Maintenance II 1750 operating hours</b></p> <p style="text-align: center;">Workshop Stamp</p> <p>completed on: at _____ operating hours</p>
<p style="text-align: center;"><b>PowerBoss System Maintenance III/S 2000 operating hours</b></p> <p style="text-align: center;">Workshop Stamp</p> <p>completed on: at _____ operating hours</p>	<p style="text-align: center;"><b>PowerBoss System Maintenance I 2250 operating hours</b></p> <p style="text-align: center;">Workshop Stamp</p> <p>completed on: at _____ operating hours</p>	<p style="text-align: center;"><b>PowerBoss System Maintenance II 2500 operating hours</b></p> <p style="text-align: center;">Workshop Stamp</p> <p>completed on: at _____ operating hours</p>	<p style="text-align: center;"><b>PowerBoss System Maintenance II 2750 operating hours</b></p> <p style="text-align: center;">Workshop Stamp</p> <p>completed on: at _____ operating hours</p>

**5.3 Maintenance schedule**

The following maintenance work must be completed by the customer at the intervals stipulated.

It relates to the daily and weekly maintenance work.

**5.3.1 PowerBoss system maintenance, customer**

Activity	Interval
	Daily
Directly prior to starting operation:	
Fill the solution tank (dose the cleaning agent, fill fresh water)	o
Before or after operation:	o
Check the properties of the deflectors to the right and left and repair them or replace the deflector rubber (left and right) as necessary	o
Check the service brake in terms of its functionality and for signs of leaks; repair as necessary	o
Check the parking brake in terms of its functionality and for signs of leaks; repair as necessary	o
Check the squeegee is clean and undamaged	o
After the end of operation:	o
Empty the waste container on the rotary brush head (several times a day, if necessary, depending on the working conditions)	o
Clean the waste container on the rotary brush head	o
Empty the recovery tank	o
Clean the recovery tank	o
Clean the large particle suction filter	o
Clean the fresh water filter	o
Check the battery charge; recharge as necessary	o

## Maintenance and Service



Before completing the weekly maintenance work described below, subject all the operating elements to a function test in order to check whether the vehicle is ready for operation.

Activity	Interval
	Weekly
Check the acid level of the battery and refill distilled water as necessary	o
Check the electrical system (including working lights) and repair any defects	o
Check the rotary brushes are fitted properly and inspect them for signs of wear (limit dimension for brush diameter is approx. 3.9 in) and damage. Check if any objects have caught in the rotary brushes. Remove any foreign bodies, repair or replace rotary brushes.	o
Check the solution feed to the brushes (water filter and function of the relief valve/pump). Note: The solution tank must be empty in this case!	o
Check the spraying pattern of the nozzles, clean the nozzles if necessary	o
Check the squeegee, particularly the rear sealing strip, is clean and for signs of damage and wear and complete any repairs or order spare parts and replace them as necessary	o
Check the recovery tank through the inspection hole at the top for signs of premature wear (due to glass splinters, metal chips, grit, etc.) or damage and clean it	o
Check the condition of the side brush unit and replace the side brushes as necessary	o
Check the vehicle is clean; clean it, if necessary	o
Complete a test drive and function test (including brake tests)	o

**5.3.2 PowerBoss system maintenance I**

The following maintenance work must be completed by an authorized PowerBoss service center.

Activity	Interval
	Every 250 operating hours
Check the battery in terms of acid level, acid density and voltage per cell; clear up any defects as necessary	0
Grease the pivoting joints	0
Check the service brake for leaks, check the main brake cylinder and actuating rods, clear any defects	0
Check the brake fluid in the service brake; refill and bleed as necessary	0
Subject the service brake to a brake tests; clear any defects as necessary	0
Check the parking brake for actuating play; repair as necessary	0
Subject the safety catch to a function test (to release the parking brake)	0
Check the steering for steering play and adjust as necessary	0
Lubricate and grease the steering	0
Check the torque of the rear wheel nuts; adjust as necessary	0
Check the rotary brush head, repair as necessary: Check the rotary brushes are fitted properly and inspect them for signs of wear (limit dimension for brush diameter is approx. 3.9 in), replace as necessary. Check the properties and condition of the brush catches and side cover with thrust bearing, clean and repair as necessary.	0

## Maintenance and Service

Activity	Interval
	Every 250 operating hours
<p>Check the rotary brush head, repair as necessary (continued):</p> <p>Check the spraying pattern of the nozzles, clean the nozzles if necessary</p> <p>Check the drive belt seal for cleanliness and no leakage. To do this, clean any dirt and fluff from the drive belt chamber, check the ventilation of the rotary brush motors in the belt chamber, clean as necessary. Then always replace the seals</p> <p>Check the parallel alignment of the holding attachment by inspecting the imprints of the brush and power consumption, repair as necessary</p>	0
Check the waste container and repair as necessary	0
Grease the joints and connecting rods on the rotary brush head	0
Check the functionality and correct adjustment (left and right) of the side brush; change as necessary	0
Check the recovery tank, particularly the lid sealing quality and filter sieve	0
Change the O-rings in the draining hose and dosing valves	0
Check the suction hose is fitted properly and for signs of damage; clear any defects as necessary	0
Test the function of the squeegee: pivoting, raising/lowering, deflecting rollers	0
Check front and rear sealing lips of the squeegee; change as necessary	0
Check the knurled nuts on the squeegee; change as necessary	0
Grease the joints and connection rods of the waste water vacuuming system	0
Adjust the support wheels on the squeegee	0
Check the vacuum at the suction hose; clear any defects	0

Activity	Interval
	Every 250 operating hours
Check the electrical safety functions: parking brake, recovery tank float switch	0
Check the visual appearance of the vehicle: color, corrosion and presence of all signs and labels	0
Check the vehicle is clean; clean it, if necessary	0
Test drive and test all function and safety-relevant components including brake tests	0
Produce test report	0
Inspection label	0
Logbook	0
On request against separate account: driver training	0

### 5.3.3 PowerBoss system maintenance II

The following maintenance work must be completed by an authorized PowerBoss service center.

Activity	Interval
	Every 500 operating hours
Complete all activities in PowerBoss system maintenance I, see paragraph 5.3.2	o
In addition:	
Check the output of the hydraulic motor (forwards, reverse); clear defects as necessary	o
Check the carbon brushes of the hydraulic motor; replace, if necessary	o
Check the brush motor output (left and right); clear defects as necessary	o
Check the carbon brushes of the brush motors; replace, if necessary	o
Check the timing belt of the rotary brush drive, if necessary, have the timing belt tension adjusted or change the timing belt (178 Hz +/-15 Hz) Change the timing belt after 1000 operating hours.	o
Check the side brush unit drive; clear defects as necessary	o
Check the carbon brushes of the side brush drive; replace, if necessary	o
Including visual inspection, test drive, test report, inspection label and logbook see paragraph 5.3.2	o

**5.3.4 PowerBoss system maintenance III/S (safety check)**

The following maintenance work must be completed by an authorized PowerBoss service center at least once a year.

Activity	Interval
	Every 1000 operating hours
Complete all activities in PowerBoss system maintenance I and II, see paragraph 5.3.2 and paragraph 5.3.3	o
In addition:	
Check the brake linings on the rear wheels; change as necessary	o
Change the brake fluid in the service brake	o
Including visual inspection, test drive, test report, inspection label and logbook see paragraph 5.3.2	o



## 5.4 Battery system

The Admiral 38C is equipped with six low-maintenance block batteries, see paragraph 3.1.8 and 4.

- (1) Battery and charge control indicator (including TSG indicator) in lefthand operating panel
- (2) Battery connection cable
- (3) Battery plug in vehicle socket
- (4) Seat console, open
- (5) Battery interconnection cable
- (6) Wiring diagram

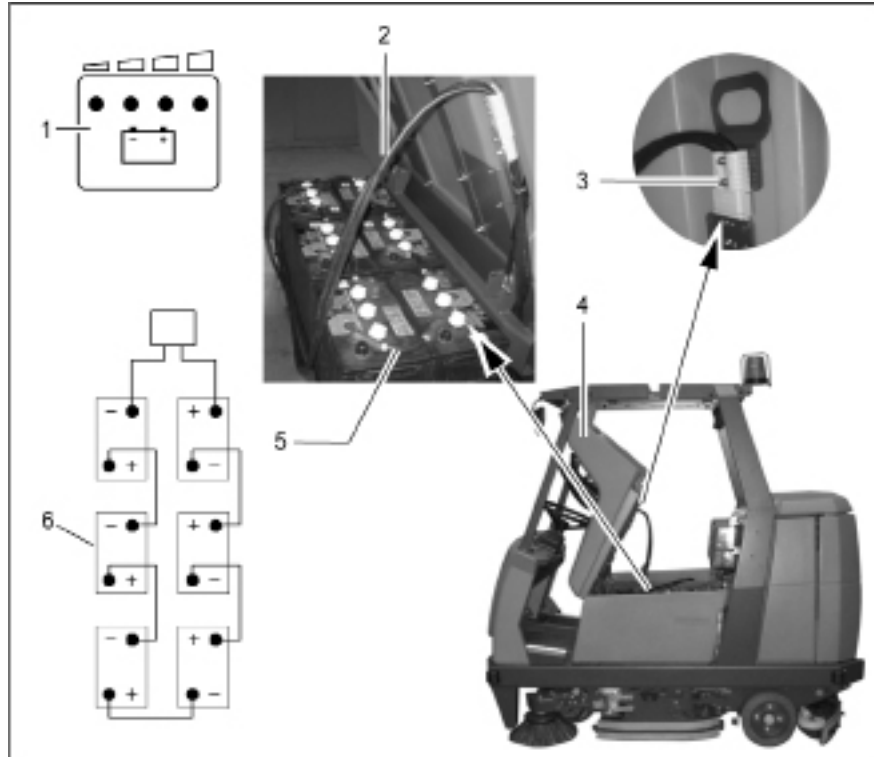

**Fig 23**

### General information on handling batteries



Pay attention to the safety information in paragraph 1.4 and 1.5.2 as well as the information on servicing and maintenance in the battery documents.

- Always disconnect the battery plug before starting any work on the electrical installation.
- Batteries may only be handled and changed by properly skilled maintenance personnel.
- Pay attention to legal requirements and local directives.

### 5.4.1 Charging batteries

Before starting the vehicle up for the first time, the batteries to be used must be properly charged by implementing the initial battery charge routine, see paragraph 2.2. PowerBoss assumes no liability for damage to the battery caused by a fault when the battery is charged for the first time.



There must be sufficient ventilation in the charging area - risk of explosion!



The seat console (Fig. 23/4) must be open during the battery charging process to prevent the development of explosive oxyhydrogen!



Only use the original charger! Pay attention that the insulation is not initially damaged and not damaged during the charging process. The cable must not rub against anything. Do not use the charger if the insulation is damaged.

We recommend charging the battery when at least one dot of the battery indicator has gone out after operating the vehicle. The indicator (Fig. 23/1) also indicates the charge status of the batteries during the charging process.

- Connect the battery plug (Fig. 23/3) to the battery charger supplied.
- Pay attention to the information in the operating manual supplied with the charger and the manual from battery manufacturer.



Do not inhale battery gases.

### 5.4.2 Servicing the driving batteries

#### Checking the acid level

The Admiral 38C is fitted with a maintenance-free battery. However, if a wet battery is used instead, the acid level must be checked by the customer on a weekly basis and distilled water must be topped up, if necessary; also see paragraph 5.3.1.

 There must be no naked flames used in the vicinity when handling batteries, particularly when checking the acid level.

The battery cells are provided with fill level indicators which ensure the correct height of electrolyte is maintained: Refill distilled water, if required. Details on the filling process are contained in the manual provided by the battery manufacturer.



Spilled battery acid must never enter the sewage system in its initial form, it must be neutralized beforehand: e.g. diluted with plenty of water or absorbed with granulate.

#### Checking the acid density and voltage of each battery

These points must be checked and corrected at regular intervals within the scope of PowerBoss system maintenance by an authorized service center.

#### 5.4.3 Disassembling the batteries

1. Park the vehicle on a level area of floor.

 Turn the key switch to position 0 and remove the key.

2. Open the side doors to the left and right (Fig. 24/3).
3. Positioned on the right-hand side of the vehicle, take hold of the seat console at the handle (Fig. 24/2) and pivot up towards the front.

 Pivot the seat console (Fig. 24/1) open from the right-hand side of the vehicle otherwise your hands could be crushed between the seat console and cab safety roof (if fitted).

4. Disconnect the battery and vehicle plug (Fig. 24/5+6).



When disassembling the batteries, use appropriate lifting gear.



The battery may only be disassembled using lifting gear by properly trained personnel.



If the Admiral 38C is equipped with a cab safety roof, lift the batteries out on the left-hand side of the battery. The cab safety roof has a recess (Fig. 24/4) for the lifting gear rope.

5. Disconnect the battery connection cable.
6. Lift the battery out of the vehicle using the lifting gear.

#### 5.4.4 Installing the batteries

 Set the key switch to position 0 (refer to „Key switch“ in paragraph 3.2.3) and remove the key.

1. Open the side doors to the left and right (Fig. 24/3).
2. Take hold of the seat console (Fig. 24/1) at the handle (Fig. 24/2) and pivot it forwards to open it.



If a cab safety roof is fitted, open the seat console from the right-hand side of the vehicle otherwise your hands could be crushed between the seat console and cab safety roof.

Install the batteries in the vehicle from the left-hand side of the vehicle using lifting gear or a fork-lift truck according to the connection diagram or adjacent figure.



If the Admiral 40CS is fitted with a cab safety roof, the batteries can only be installed from the left-hand side of the vehicle; the cab safety roof is provided with a recess for the lifting gear rope.



When installing the battery, use appropriate lifting gear.



The batteries may only be installed using lifting gear by properly trained personnel.

Connect the battery poles to the connection cable according to the connection diagram. Ensure they are connected firmly.

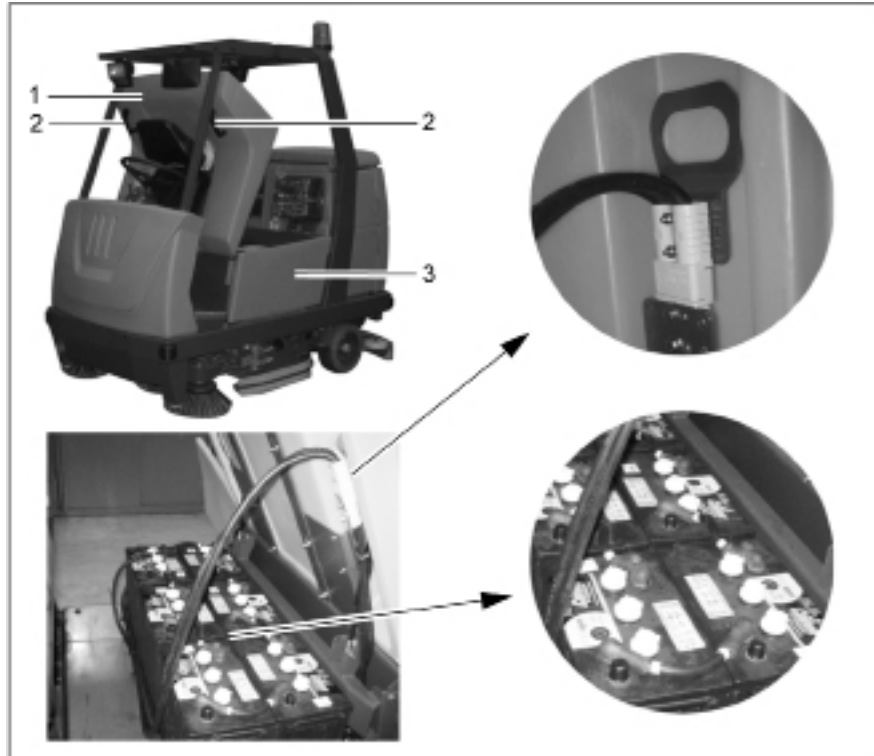

**Fig 24**

### 5.4.5 Disposing of batteries

Also see paragraph 3.1.8.

Used batteries with the recycling symbol contain reusable commodities. The heavy metals contained simultaneously represent a serious risk to health and to the environment. Never open batteries or damage them. Never touch, inhale or swallow any material inside batteries. Health hazard! Never allow batteries to pollute the environment. Risk of contaminating the ground and water! In accordance with symbol with the crossed out bin, these batteries must not be disposed of in domestic waste.

### 5.4.6 Total discharge signal transducer (TSG)

The Admiral 38C is equipped with a charge control for protection against total discharge of the batteries. The total discharge signal transducer (TSG) is integrated in the electronic system and setup at the factory. If other batteries are used, the total discharge signal transducer must be adjusted.



The total discharge signal transducer may only be adjusted by an authorized PowerBoss service center.

### 5.5 Solution tank

- (1) Lid seal
- (2) Tank cap
- (3) Opening to recovery tank  
(airing and venting)
- (4) Solution tank
- (5) Solution filter
- (6) Ball cock
- (7) Screw cap
- (8) Draining hose

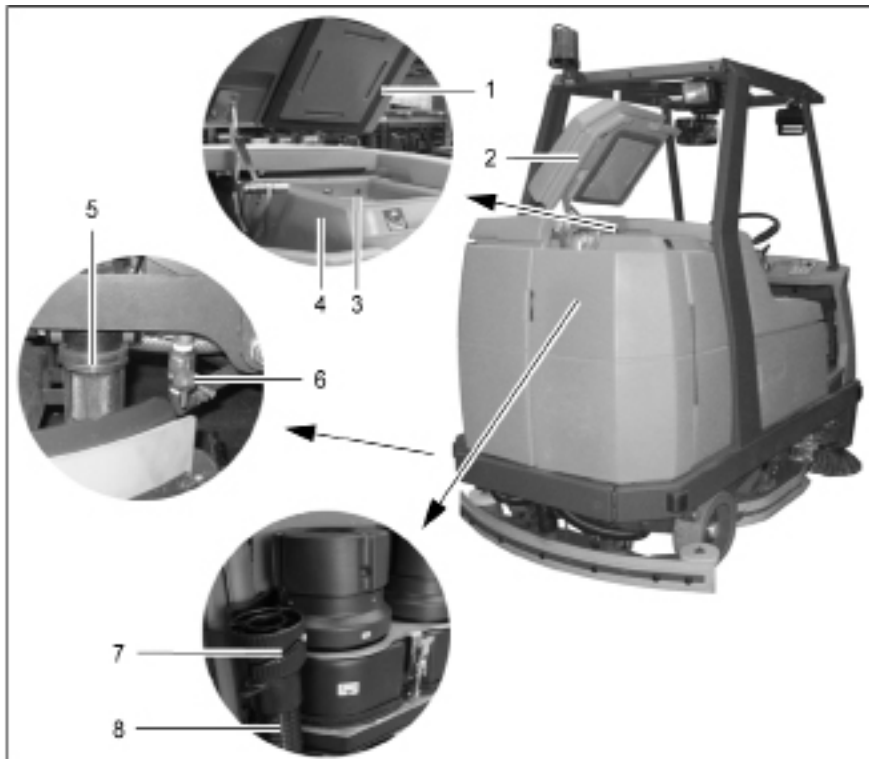

Fig 25

### 5.5.1 Filling the solution tank

Fill the solution tank (Fig. 25/4) with fresh water and cleaning agent before starting with the work, also refer to Section 3.1.4.

1. Park the machine on a level floor area.
2. Open the tank cap (Fig. 25/2) and lock in place.
3. Fill the solution tank to the maximum mark.

### 5.5.2 Emptying the solution tank

If the vehicle is to be left unused for a longer period, the solution tank should be emptied.

1. Park the vehicle so that the draining hose can be positioned over a drain in the floor.
2. Open the left and right rear doors
3. Detach the solution draining hose (Fig. 25/8) and lower it slowly.
4. Unscrew the cap (Fig. 25/7) to open it. The quantity drained can be regulated by turning the cap and pivoting the cap open fully, if necessary.
5. When the solution tank has been completely emptied, screw the cap shut again and attach the draining hose again.
6. Close the left and right rear doors.



When disposing of the waste water containing the cleaning agent, observe all applicable legal regulations.

### 5.5.3 Cleaning the draining hose cap

- The cap (Fig. 25/7) at the end of the draining hose (Fig. 25/8) should be cleaned at regular intervals.
- Lubricate the O-ring lightly, if necessary.

### 5.5.4 Cleaning the filter in the solution feed

The solution feed is equipped with a filter (Fig. 25/5) which must be cleaned dirt appears on the container. This is located on the left-hand side of the vehicle at the height of the brushes behind the side panel.

1. Pivot the right-hand side panel up.
2. Close the ball cock (Fig. 25/6) to prevent solution being supplied from the tank.
3. Unscrew the container by hand and pull the sieve insert out downwards.
4. Clean both parts with water and reassemble them.

### 5.6 Recovery tank

- (1) Tank cap
- (2) Lid seal
- (3) Recovery tank
- (4) Air intake filter
- (5) Screw cap
- (6) Waste water draining hose
- (7) Cleaning flap

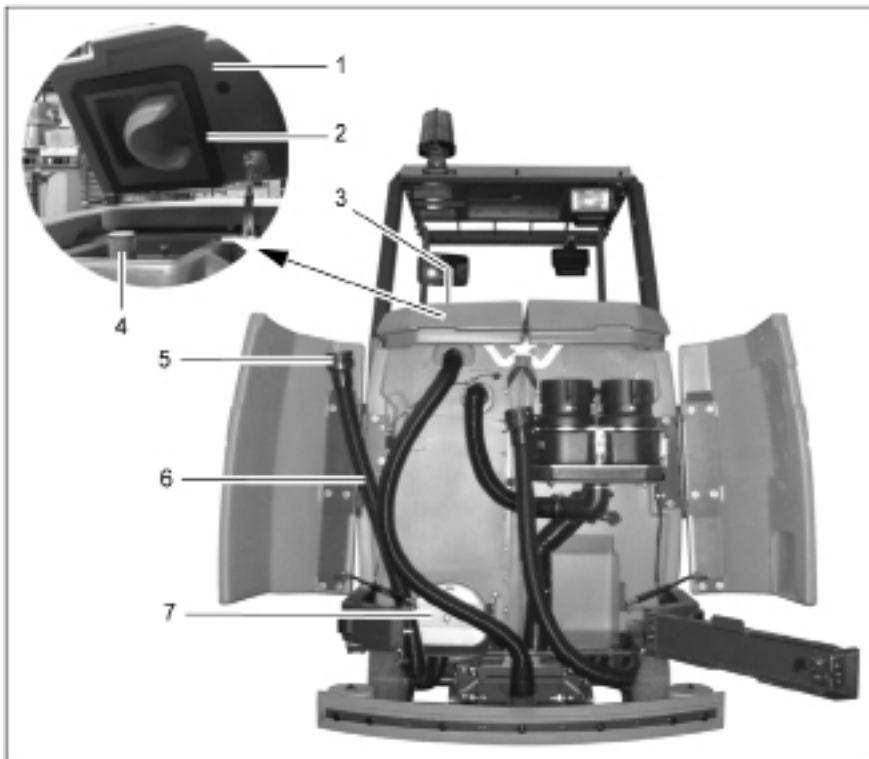

Fig 26



### 5.6.1 Emptying the recovery tank



The recovery tank (Fig. 26/3) must be emptied and flushed clean after finishing work.



Observe the applicable laws and local regulations when disposing of waste water containing cleaning agents!

1. Park the vehicle so that the draining hose can be positioned over a drain in the floor.
2. Open the left and right rear doors
3. Detach the waste water draining hose (Fig. 26/6) and lower it slowly.
4. Unscrew the cap (Fig. 26/5) to open it. The quantity drained can be regulated by turning the cap and pivoting the cap open fully, if necessary.
5. When the recovery tank has been completely emptied, screw the cap shut again and attach the draining hose again.



If the recovery tank is extremely dirty, begin cleaning the tank straight away.

6. Close the left and right rear doors.

### 5.6.2 Cleaning the recovery tank

Clean the recovery tank (Fig. 26/3) every day or as necessary. The cleaning flap (Fig. 26/7) is available for this.

1. Open the left and right rear doors
2. Empty the recovery tank, refer to Section 5.6.1.

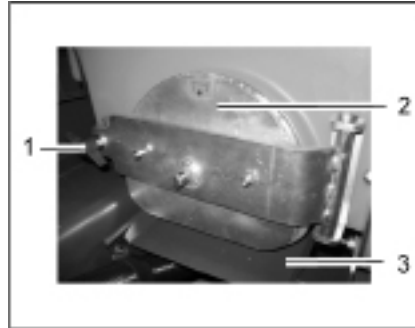

**Fig 27**

3. Pull out the run-off plate (Fig. 27/3)
4. Release the flap lock: Turn the wing nut (Fig. 27/1) counterclockwise
5. Open the cleaning flap (Fig. 27/2).
6. Open the recovery tank cap (Fig. 26/1).
7. Flush the recovery tank with water filled from the top through the open tank neck.



Cleaning may only be carried out using a water hose (operating pressure approx. 5 to 6 bar) and only from top to bottom. Do not aim the jet of water directly at openings, slits, electronic components, operating panels or seals.



It is not permitted to clean the vehicle with a high-pressure washer or with a steam blaster because the temperature is in excess of 100 °C.



Wear appropriate gloves for protection against dirt, viruses, bacteria etc. when cleaning the container.

8. After finishing cleaning the tank, close the flap and push the run-off plate back in place.
9. Unhook the waste water draining hose (Fig. 26/6), lower it slowly and open the cap (Fig. 26/5).
10. Run fresh water in the recovery tank through the open tank neck using a water hose (output pressure approx. 5 to 6 bar) and, in doing so, also flushing the draining hose (see above).
11. Screw the cap shut again and hook the draining hose back in place.
12. Close the left and right rear doors.



The cleaning flap must not be used to drain off waste water.

### 5.6.3 Cleaning the draining hose cap

- Clean the draining hose cap on a daily basis.
- Lubricate the O-ring lightly, if necessary.

### 5.6.4 Cleaning the air intake filter

The filter sieve (Fig. 28/1) is located in the recovery tank above the maximum water level on the suction pipe. The accumulation of dirt in the filter sieve must be checked daily and cleaned as necessary:

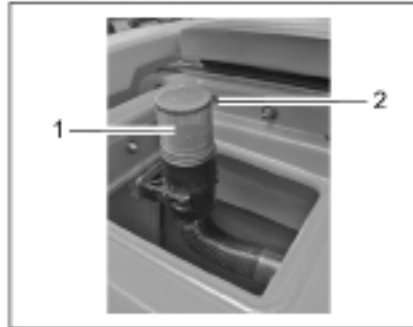

Fig 28

1. Pull the filter sieve from the suction pipe and clean with water.



Remove the filter sieve completely to clean it.



During cleaning and operation, pay attention that no water and no particles of dirt get into the suction pipe and into the suction turbines.

2. Dry the filter sieve after cleaning. Do not replace when dripping wet!

### 5.6.5 Cleaning the openings to the solution tank

The openings between the recovery and solution tank (Fig. 28/2) serve for ventilation between the two tanks. They must be checked regularly for accumulations of dirt and cleaned as necessary.

### 5.7 Rotary brush head



The rotary brush head (Fig. 29/2) may only be assembled, disassembled and adjusted by properly trained service personnel.

The two rotary brushes (Fig. 29/3) are not component parts of the delivery. They must be selected separately according to the task they are intended to fulfill (refer to Section 4) and installed according to the instructions on the rotary brush head (Fig. 29/2), refer to Section 2.3.1. Normally, however, the authorized PowerBoss workshop will install them for you prior to delivery.



Before working on the rotary brushes, switch off the rotary brush head, turn the key switch to Position 0 and remove the key.



The following applies prior to starting any maintenance work on the rotary brush head: Open the deflectors and move them to their service position (Fig. 29/1) (also refer to Section 2.3.1, Point 1).

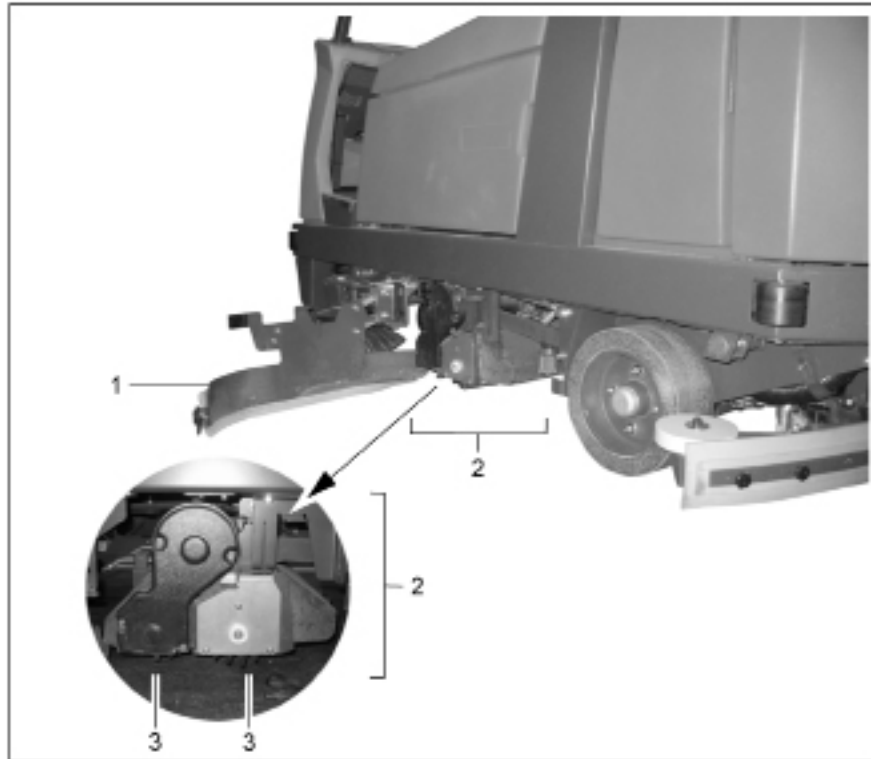

**Fig 29**

### 5.7.1 Emptying and cleaning the waste container



The waste container must be emptied and cleaned at least once a day. If the vehicle is used for several hours a day, the waste container must be checked and correspondingly more frequently emptied.



Observe the applicable laws and local regulations in respect of disposal!



Only remove the container in the direct vicinity of the refuse dump.

#### Removing the waste container



The waste container (Fig. 30/1) can only be removed on the right-hand side of the vehicle.

1. Take hold of the waste container (Fig. 30/1) by the handle (Fig. 30/4) and pivot it back to the left a little to unlock it.
2. Pull the waste container (Fig. 30/1) out using the handle (Fig. 30/4).

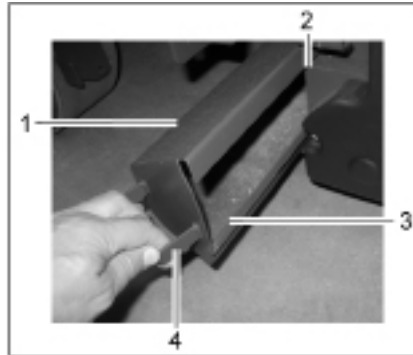

**Fig 30**

- (1) Waste tank
- (2) Guide edge
- (3) Throw-in edge
- (4) Handle

#### Emptying the waste container



The waste container cannot be filled higher than the throw-in edge (Fig. 30/3).

Empty the waste container (Fig. 30/1) regularly at a suitable location.

#### Cleaning the waste container

Wash and clean the waste container (Fig. 30/1) with water.

#### Installing the waste container

Position the waste container (Fig. 30/1) on the guide edge (Fig. 30/2) and slide in, from the right-hand side, until it will go no further.

### 5.7.2 Changing the rotary brushes



Check the rotary brushes on a weekly basis for signs of wear.

When a rotary brush has worn to a diameter of approx. 3.9 in, the rotary brushes must be replaced by new ones (diameter of new rotary brush: 5.4 in).



To protect the floor surface, the rotary brushes are equipped with a wear restriction facility. When the minimum diameter is reached, the rotary brush head lowers onto a vertical stop. The full cleaning performance can no longer be achieved when in this position.

- (1) Locking lever
- (2) Oval-head screws
- (3) Hex nut
- (4) Contact surfaces
- (5) Rotary brush
- (6) Brush holder
- (7) Contact surface between brush holder and oval-head screws

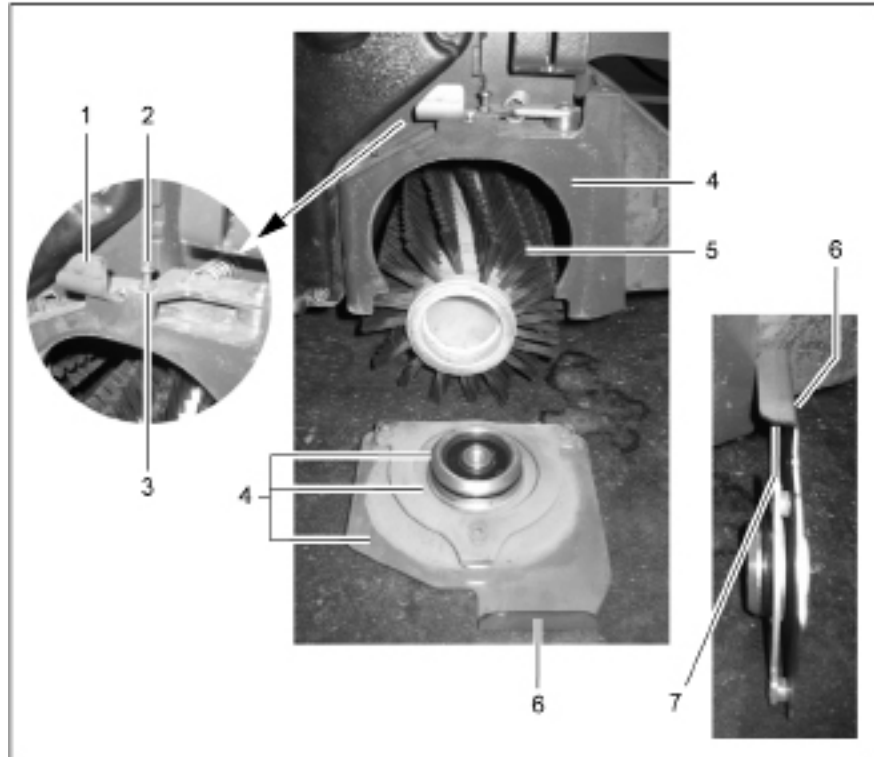

**Fig 31**

### Removing the brush holder

1. Slide the locking lever (Fig. 31/1) to the middle of the device and hold it there.
2. Allow the brush holder (Fig. 31/6) to lower under its own weight and then pull out.
3. Release the locking lever (Fig. 31/1).

### Disassembling the rotary brushes

Pull out the rotary brush (Fig. 31/5), overcoming its resistance. Also refer to Section 2.3.1 (reverse working sequence).

### Installing the rotary brushes

Refer to Section 2.3.1.

### Mounting the brush holder

1. Slide the locking lever (Fig. 31/1) to the middle of the device and hold it there.
2. Mount the brush holder (Fig. 31/6) on the rotary brush, press against the housing and then slide upwards as far as possible.
3. Pivot the locking lever (Fig. 31/1) back under the brush holder as far as possible.

### 5.7.3 Cleaning the contact surfaces

Each time the rotary brushes are changed, all the contact surfaces (Fig. 31/4 and Fig. 29/7) must be thoroughly cleaned with a damp cloth, with a little cleaning agent added, if necessary.



Also clean the small contact surfaces!

### 5.7.4 Adjusting the locking lever for the brush holder

1. Remove the brush holder (Fig. 31/6) (refer to paragraph "Removing the brush holder").
2. Loosen the counternut (Fig. 31/3).
3. Screw the oval-head screw (Fig. 31/2) in or out.
4. Close the brush holder (refer to paragraph "Mounting the brush holder") on a trial basis.



The oval-head screw (Fig. 31/2) is adjusted correctly when it lightly scrapes under the brush holder (Fig. 31/7).

5. Remove the brush holder (Fig. 31/6) (refer to paragraph "Removing the brush holder") and adjust the oval-head screw (Fig. 31/2) until it is at the correct height (repeat Step 4 several times if necessary).
6. Tighten the counternut (Fig. 31/3).

### 5.7.5 Installing new rubber deflector strips



The deflector (Fig. 32/1) must be fixed in its service position (refer to Section 2.3.1, Point 1).

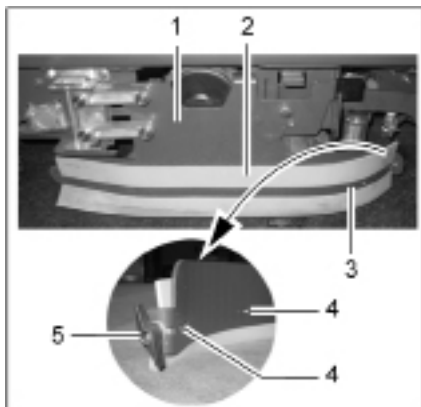

**Fig 32**

- (1) Deflector
- (2) Rubber deflector strips
- (3) Clamping rail
- (4) Clamping rail hooks
- (5) Wing nut

1. Loosen the wing nut (Fig. 32/5) at the end of the deflector.
2. Slide the clamping rail (Fig. 32/3) in the vehicle's driving direction (forwards) until the clamping rail hooks (Fig. 32/4) are freed and the clamping rail can be removed away from the vehicle.
3. Remove the old rubber deflector strips (Fig. 32/2).
4. Position the new rubber deflector strips (Fig. 32/2) in place.
5. Mount the clamping rail (Fig. 32/3) from the outside and slide back by hand so that the clamping rail hooks (Fig. 32/4) engage.
6. Tighten the wing nut (Fig. 32/5) so that it engages in the thread of the clamping rail (Fig. 32/3) and tightens the clamping rail firmly.

### 5.7.6 Adjusting the rotary brush head

If you notice that the cleaning performance of the vehicle is no longer regular, make a visual inspection as to whether the rotary brush head has a greater clearance from the ground on one side compared to the other. If this is the case, contact an authorized PowerBoss service center to have the rotary brush head readjusted. A PowerBoss service center has the tools necessary to do this.



This work may only be completed by an authorized PowerBoss service center!

### 5.7.7 Direction of rotation of the rotary brushes



Controlling and adjusting the direction of rotation may only be carried out at an authorized PowerBoss service center.

When viewing the front left side of the vehicle, the front rotary brush (Fig. 33/ 1), viewed in the driving direction, must rotate counterclockwise and the rear rotary brush (Fig. 33/2) clockwise.

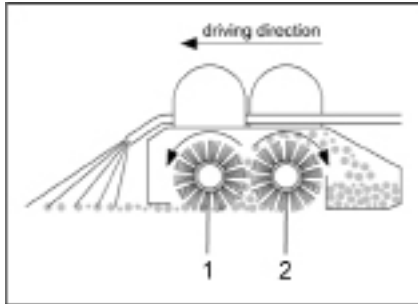

**Fig 33**

- (1) Front rotary brush
- (2) Rear rotary brush



### 5.8 Squeegee

- 1 Squeegee holding attachment
- 2 Wing nuts
- 3 Connection nozzle
- 4 Sealing strip (rear)
- 5 Support strip (rear)
- 6 Clamping rail (rear)
- 7 Knurled nut

The squeegee is also equipped with front sealing and support strips and clamping rail (Fig. 35).



**Fig 34**

4. Open the rear doors.
5. Pull the suction hose from the connection nozzle (Fig. 34/3) of the squeegee.
6. Loosen the wing nuts (Fig. 34/2) on the holding attachment.
7. Pull the squeegee away to the rear under the holding attachment.
8. Insert the key in the key switch and turn the key switch on.

9. The squeegee is lifted automatically.
10. Close the rear doors.

#### 5.8.1 Cleaning the squeegee

Inspect the squeegee when raised daily and clean as necessary.

#### 5.8.2 Disassembling the squeegee

1. Insert the key in the key switch and turn the key switch on.
2. Lower the squeegee: Press the button for the squeegee and suction turbine so that the green control lamp lights up.
3. Switch off the key switch and remove the key.

#### 5.8.3 Installing the squeegee

Refer to Section 2.3.2.

### 5.8.4 Changing the sealing strips

The sealing strips can be changed without the need for tools:

1. Disassemble the squeegee, refer to Section 5.8.2
2. Unscrew the knurled nuts (Fig. 34/7).
3. Remove the clamping rail, support strip and sealing strip (Fig. 34/4-6).



Both sides of the sealing strip can be used.

4. Install the new or reversed sealing strips in the reverse working sequence.



Pay attention that both sealing strips (front and rear) touch the floor when mounted.

5. Tighten the knurled nuts evenly, starting from the center and working on alternate sides.



There must be no bends in the sealing strip.

Disassemble the front sealing strip (Fig. 35) in the same way.

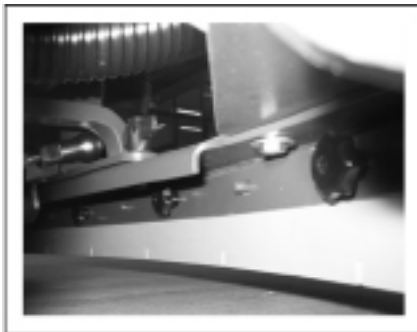

**Fig 35**

## 5.9 Wheels

### 5.9.1 Front wheel

In the case of problems with the front wheel, please contact an authorized PowerBoss service center.



The front wheel may only be changed at an authorized PowerBoss service center.

### 5.9.2 Rear wheels



**Fig 36**

- The wheel nuts on the rear wheels (Fig. 36/1) must be subject to their first check after 100 operating hours and subsequently every 200 hours.



The tightening torque for the wheel nuts (Fig. 36/1) is 140 Nm.

### Changing the rear wheels

- To change the rear wheels, the Admiral 38C must be jacked up on the right or left side.
- The contact points for the jack (lifting force: 2.0 t) are on the vehicle frame in front of the rear wheels.

### Removing the rear wheels

- Remove the wheel nuts (Fig. 36/1).
- Remove the wheel.

### Mounting the rear wheels

- Install the wheel in place.
- Screw on and tighten the wheel nuts (Fig. 36/1).

## 5.10 Electrical installation

### 5.10.1 Red control lamps

Refer to Section 3.2.2.

### 5.10.2 Error codes

Refer to Sections 3.5.1 and 3.2.2.

### 5.10.3 Fuses

The fuses are located in the electronic system underneath the seat console. Take hold of the seat console by the handle and pivot it up.



Always disconnect the battery plug before starting any work on the electrical installations.

All the lifting elements and brush motors in the Admiral 38C are equipped with safety fuses and electronic fuses.

Safety fuses are installed in:

- The suction turbines (35A high current fuse)
- The water pump and relief valve for the water supply (10A plug-in fuse)
- The hydraulic motor (160A current limiter in the drive control) and

- The working lights and flashing beacon, the key switch and horn (10 A plug-in fuse (F51)).



When these fuses blow, the vehicle is out of operation. This is not indicated by an alarm signal on the operating panel!

### 5.10.4 Drive control relay

The drive control is located in the left hand part of the driver's cab underneath the foot plate.



Always disconnect the battery plug before starting any work on the electrical installations.

- Loosen the screws in the foot plate and remove the foot plate.
- Relay K3 (main contactor) is mounted in front of the drive control.
- Replace a defect relay with a new one.
- Replace the foot plate and fix by means of the screws.

### 5.11 Cleaning the vehicle

- Clean the vehicle on a weekly basis, refer to Section 5.3.1.
- Park the vehicle in an appropriate washing area.



Observe the applicable laws and local regulations when disposing of water containing cleaning agents and dirt!

- Switch the vehicle off and remove the key.
- The vehicle may only be cleaned using a water hose (operating pressure approx. 5 to 6 bar) and only from top to bottom.



It is not permitted to clean the vehicle with a pressure washer or steam blaster.

- Do not aim the jet of water directly at openings, slits, electronic components, operating panels or seals.
- It is not permitted to use aggressive and corrosive cleaning agents.
- Allow the vehicle to dry after cleaning. It is preferable to allow the vehicle to dry over a longer period of time, e.g. the weekend.

### 5.12 Transporting and towing Loading



Check the load bearing capacity of the loading platform prior to loading.

- Dead weight of the Admiral 38C without battery, without options and without driver: 1561 lbs
- Total weight of the Admiral 38C with battery and filled solution tank, with cab safety roof and side scrubbing unit, without driver: 2919 lbs
- When loading onto a truck or something similar by means of a loading ramp, the ramp angle must not exceed 20%.
- The squeegee and brush head must be raised.

### Transporting the vehicle

- When transporting the vehicle using lifting gear to the site of use, the squeegee and rotary brush head must be raised.
- When the vehicle is to be transported on another vehicle or trailer, it must be secured against rolling away. Lash the vehicle down securely.
- There are attachment points for this on the left as well as on the right: At the rear on the frame and at the sides near the entry point.
- The attachment points are bolts (Fig. 37/1+2) which can be pulled out from the sides of the frame. The bolts are locked in their projecting position by turning them.
- The bolts also serve for loading by a crane.

### Towing the vehicle

If it should become necessary to tow the Admiral 38C, only do it on a level floor and at a maximum towing speed of 4 kph. The tow rope must be attached at the front lashing points.

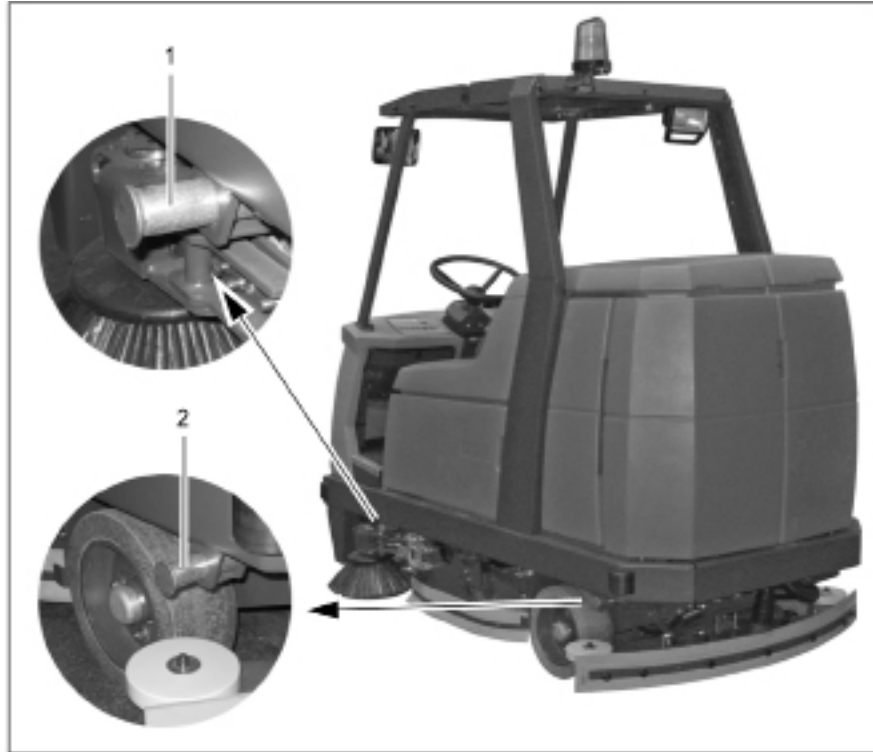

**Fig 37**

## 6 WARRANTY

Revision F  
Effective November 1, 2008  
PowerBoss Made Simple Industrial Limited Warranty

Minuteman International owner of PowerBoss warrants to the original purchaser/user that the product is free from defects in workmanship and materials under normal use. PowerBoss will, at its option, repair or replace without charge, parts that fail under normal use and service when operated and maintained in accordance with the applicable operation and instruction manuals. All warranty claims must be submitted through and approved by factory authorized repair stations.

This warranty does not apply to normal wear, or to items whose life is dependent on their use and care. Parts not manufactured by PowerBoss are covered by and subject to the warranties and/or guarantees of their manufacturers. Please contact Minuteman International for procedures in warranty claims against these manufacturers.

**Special warning to purchaser** -- Use of replacement parts not manufactured by PowerBoss or its designated licensees, will void all warranties expressed or implied. A potential health hazard exists without original equipment replacement.

All warranted items become the sole property of Minuteman International or PowerBoss or its original manufacturer, whichever the case may be.

PowerBoss disclaims any implied warranty, including the warranty of merchantability and the warranty of fitness for a particular purpose. PowerBoss assumes no responsibility for any special, incidental or consequential damages.

This limited warranty is applicable only in the U.S.A. and Canada, and is extended only to the original user/purchaser of this product. Customers outside the U.S.A. and Canada should contact their local distributor for export warranty policies. PowerBoss is not responsible for costs or repairs performed by persons other than those specifically authorized by PowerBoss. This warranty does not apply to damage from transportation, alterations by unauthorized persons, misuse or abuse of the equipment, use of non-compatible chemicals, or damage to property, or loss of income due to malfunctions of the product. If a difficulty develops with this machine, you should contact the dealer from whom it was purchased.

This warranty gives you specific legal rights, and you may have other rights, which vary from state to state. Some states do not allow the exclusion or limitation of special, incidental or consequential damages, or limitations on how long an implied warranty lasts, so the above exclusions and limitations may not apply to you.

## WARRANTY



	Travel*	Labor	Parts	Engine	Extended Warranty	Costs
<b>Walk behinds</b>						
Battery sweepers	Ninety days	One year	One year	N/A	2 years Parts + Labor (or 2000 Hours)	2%
IC sweepers	Ninety days	One year	One year	Through manufacturer	2 years Parts + Labor (or 2000 Hours)	2%
Battery scrubbers	Ninety days	Two years	Three years	N/A	3 Years Parts + Labor (or 3000 Hours)	2%
<b>Riders</b>						
Battery scrubbers	Ninety days	Two years	Three years/2000 hrs	N/A	3 Years Parts + Labor (or 3000 Hours)	2%
IC sweeper/scrubbers	Ninety days	Six months	Two years/2000 hrs	Two years/3000 hrs**	2 years Parts + Labor (or 2000 Hours)	3%
IC sweepers	Ninety days	Six months	Four years/3000 hrs	Five years/3000 hrs**	4 Years Parts + 2 Years Labor (or 4000 Hours)	3%
<b>Exceptions</b>						
Apex series sweeper	Ninety days	One year	One year/1000 hrs	One year/1000 hrs**	2 years Parts + Labor (or 2000 Hours)	3%
6X sweeper	Ninety days	Six months	Two years/2000 hrs	Two years/2000 hours**	2 years Parts + Labor (or 2000 Hours)	3%

**Tank Bladders** Eight years/ no additional labor  
**Polypropylene plastic tanks** Ten years/ no additional labor  
**Batteries** 0-3 months full replacement, 4-12 prorated credit  
**Chargers** One-year replacement  
**Replacement parts** Ninety days  
**\*Two-hour cap**

**\*\*Through engine manufacturer. See section 3 of warranty manual for engine warranty exceptions**

**\*\*\* Based upon dealer's certification status**

Extended Warranty MUST be signed up within 30 days of delivery to End User (Dealer has 1Year from Receiving Machine to Sign up extended Warranty)

Extended Warranty Cost is based on Invoice Price multiplied by the Percentage listed in the Extended Warranty Column

*All above labor and travel reimbursed at 65 or 75% of the published shop rate.*



**PowerBoss**<sup>®</sup>  
The Power of Clean

***“The Power of Clean”***

**PowerBoss Is A Full Line Manufacturer Of Sweepers and Scrubbers For  
Industrial Facilities.**

PowerBoss, Inc 175 Anderson Street P.O. Box 1227- Aberdeen North Carolina 28315

Phone: 800-982-7141 - Fax: 1-800-277-7141 Local: 910-944-2105 Fax: 910-944-7409 e-mail: [techsupport@powerboss.com](mailto:techsupport@powerboss.com)

**A Member Of The Hako Group**