



Propane Hard Floor Machine
PE430GP
Operator's Manual



Instructions For Use

Failure to read and understand this manual before operating this machine or performing service on this machine may result in injury to the operator or nearby personnel or result in damage to the machine or nearby property. Each operator must be trained in the operation of this machine before being allowed to use it. Contact Amano Pioneer Eclipse Customer Service at 1-800-367-3550 or +1-336-372-8080 or an authorized Amano Pioneer Eclipse Distributor to inquire about training or to request a replacement manual.

NOTICE

Proper maintenance is necessary with all propane powered floor machines. Following the scheduled maintenance procedures found in your operation manual will provide many years of uninterrupted service.



In addition to the scheduled maintenance procedures listed it is recommended to have your machine serviced by certified service personnel every three months. This service should include an emissions check.

DANGER! For your safety, if you smell propane:

1. Extinguish any open flame.
2. Open window.
3. Do not touch electrical switches.
4. Immediately call your propane supplier.

DANGER! Do not store or use gasoline or other flammable vapors and liquids in the vicinity of this or any other appliance.

Record This Important Information		
Date of Purchase	_____	
Purchased From	_____	
Address	_____	
City	State	Zip
_____	_____	_____
Phone	Contact	_____
_____	_____	_____
Machine Model	_____	
Machine Serial Number	_____	
Important Phone Numbers		
Medical Emergency	_____	
Police	_____	
Fire Department	_____	

In this Operation Manual you will find three statements that you must read and observe to ensure safe operation of this machine.

DANGER! indicates that the possibility of severe bodily injury or death can occur if DANGER! statements are ignored. Read and observe all DANGER! statements included in the Operation Manual and attached to the machine.

WARNING! indicates that the possibility of bodily injury to the operator and other people can occur if WARNING! statements are ignored. Read and observe all WARNING! statements included in the Operation Manual and attached to the machine.

CAUTION! indicates that the possibility of damage to the machine or other property can occur if CAUTION! statements are ignored. Read and observe all CAUTION! statements included in the Operation Manual and attached to the machine.

Table of Contents

Quick Reference Specifications.....	6	Inspect Fuel Hose and Connections.....	23
Safety Precautions.....	7	Oil Level Inspection.....	24
Refueling and Storage of Fuel Cylinders.....	9	Oil Change.....	24
Operator Responsibility.....	9	Oil Filter Replacement.....	25
Canadian Safety Requirements.....	10	Spark Plug Inspection and Replacement.....	25
Test for Operator-Ear Sound Pressure Level.....	11	Valve Clearance & Re-torque Heads.....	25
Test for Hand Arm Vibration.....	11	Valve Seating.....	25
Machine Preparation.....	12	Head Bolt Maintenance.....	25
Unpacking the Machine.....	12	Cooling Fin Maintenance.....	25
Filling the LP Cylinder.....	12	Inspect Drivers / Pad Holders.....	25
Installing the LP Cylinder.....	12	Belt Maintenance.....	26
Controls and Instruments.....	13	Belt Replacement.....	26
Ignition Switch.....	14	Shear Pin Replacement.....	27
Engine Throttle.....	14	Battery Maintenance.....	27
Hour Meter/Tachometer.....	14	Gearbox Maintenance.....	28
Safety Bail.....	14	Check Gearbox Oil Level.....	28
Solution Control.....	14	Changing Gearbox Oil.....	28
EcoSense Emission Monitoring.....	15	Gearbox Replacement.....	30
Deck Switch.....	15	Machine Storage.....	30
Handle Pivot Knob.....	15	Repacking the Machine.....	30
Handle Adjustment/ Position.....	16	Loading the Machine for Transport.....	31
Fuse.....	16	Transporting the Machine.....	31
Solution Tank.....	16	Machine Specifications.....	32
Head Change.....	17	Parts Manual.....	33
How the Machine Works.....	18	Electrical Schematic.....	34
Pre-Operation Checklist.....	18	Connections.....	35
LP Fuel Cylinder.....	18	Engine Assembly.....	36
Installing the LP Fuel Cylinder.....	18	Regulator & Handle Assembly.....	38
Starting the Machine.....	19	Bulkhead & Control Panel Assembly.....	40
Idling and Stopping the Machine.....	19	Frame Assembly.....	42
Work Site Transporting.....	19	Gearbox Assembly.....	44
Operating the Machine.....	20	Front Main Assembly.....	46
Splash Skirt.....	20	Rear Main Assembly.....	48
Machine Troubleshooting.....	21	Head / Driver Assembly.....	50
Scheduled Maintenance.....	22	Safety Awareness Form.....	51
Maintenance.....	23	Small Off Road Engine Certification Warranty.....	53
Air Filter Inspection and Replacement.....	23	Manufacturer's Warranty.....	54
Engine Dust Filter.....	23		

Quick Reference Specifications:

Capacities:

- Engine Oil:
 - Filter not removed: 1.6qt. (1.5L)
 - Filter removed: 1.8qt. (1.7L)
 - Engine Oil Type: SAE30 with API Service Classification SH or SJ
- Gearbox Oil (Each): 16 US oz (473ml)
 - Gearbox Oil Type: AGMA 5EP
- Solution Tank: 9 US Gallons (34.1 L)

Routine Maintenance Parts:

- Engine Dust Filter: MP371300
- Engine Oil Filter: KA490657007
- Engine Primary Air Filter: KA110130752 (Paper Element)
- Engine Air Pre-Cleaner: KA110137046 (Foam Element)
- Spark Plug: KA920702112
- Battery: MP120800
- Drive Belt: MP439900
- Fuses: SS2570 (20A)
- LP Cylinder: MP105900 (Steel)
- Pad Holders / Brushes
 - 17" Pad Holder: MP178800
 - 17" Mal-Grit Brush: MP178900
 - 17" Mal Grit Xtra: MP179100
 - 17" Diamond Driver: MP496100
- Splash Skirt: MP495000

Your Authorized Amano Pioneer Eclipse Distributor: _____

Authorized Amano Pioneer Eclipse Distributor Phone Number: _____

Amano Pioneer Eclipse Phone Number: +1-336-372-8080

Safety Precautions

Anyone operating the machine should read the following carefully and be informed of potentially dangerous operating conditions. Operators should be familiar with the location and use of all safety devices on the machine. Do not use the machine if it is not in proper operating condition, and report any damage or operation faults immediately.

DANGER! Operate this machine in a well-ventilated area. It is the responsibility of the machine operator, machine owner, and the site manager to ensure that the air exchange system where the machine is to be used is in compliance with local building codes and is operating properly. Failure to operate this machine in a well-ventilated area could lead to sickness, injury, or death from carbon monoxide (CO) exposure.

DANGER! This machine emits CO, which is colorless, odorless, non-irritating gas. The first symptoms of CO exposure include headache, drowsiness, dizziness, and nausea. If you should experience any of these symptoms while operating the machine, shut off the machine and go outside to get fresh air. Have the machine tested for CO emissions by a qualified service technician before using it again.

DANGER! Prolonged or high exposure to CO may result in vomiting, confusion, and collapse in addition to loss of consciousness and muscle weakness. If such symptoms occur, call 911 for emergency medical attention. If you have experienced these symptoms, **DO NOT** operate this machine or any other propane machine again until cleared by a physician. Excessive exposure to CO can result in death.

DANGER! Propane is a highly flammable fuel. If you smell propane, shut off the machine immediately and take it outside the building. **DO NOT** use the machine again until a qualified service technician has corrected the propane leak. **DO NOT** use or allow another person to use an ignition source such as a cigarette lighter near the propane machine. **DO NOT** smoke near the propane machine. **DO NOT** vent a propane cylinder inside a building. **DO NOT** store propane cylinders inside a building.

DANGER! This machine has parts, including the pad assemblies, that can cause severe injury if these parts are contacted while they are moving. **DO NOT** allow any part of the body or clothing to come in contact with these parts while they are moving. **DO NOT** try to change attachments while the machine is running. **DO NOT** allow other people to come near the machine while it is in operation. **DO NOT** allow the machine to run unattended. **DO NOT** leave the machine in a place where unauthorized or untrained personnel could use the machine. **DO NOT** run the machine with the pad off center, damaged or missing. **DO NOT** run machine with unsecured guards and shields. **DO NOT** operate the machine if the machine has loose parts.

DANGER! Federal law and California State law prohibits the following acts or the causing thereof: (1) the removal or rendering inoperative by any person other than for purposes of maintenance, repair, or replacement, of any device or element of design incorporated into any new engine for the purpose of emission control prior to its sale or delivery to the ultimate purchaser or while it is in use, or (2) the use of the engine after such device or element of design has been removed or rendered inoperative by any person.

Among those acts presumed to constitute tampering are the acts listed below: **DO NOT** tamper with the original emission related part.

- Throttle body and internal parts
- Spark plugs
- Magneto or electronic ignition system
- Air cleaner elements
- Crankcase
- Cylinder heads
- Breather chamber and internal parts
- Intake pipe and tube
- Regulator
- Fuel lock-off

WARNING! Overfilled or liquid withdraw cylinders can damage the fuel system and create a fire hazard. **DO NOT** overfill the cylinder or use a liquid withdraw cylinder on the machine. If the regulator freezes stop the burnisher and take the cylinder outside. Inspect cylinder, if a vapor withdraw cylinder, use gloves or pliers to open bleeder valve and purge cylinder until only vapor is escaping. If it is a liquid withdraw cylinder, replace with a vapor withdraw cylinder. Both cylinders are shown below.

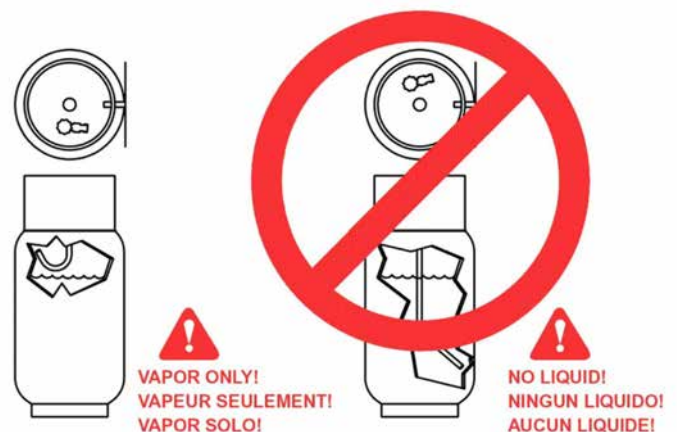

WARNING! Modifications or alterations to this machine can lead to personal injury or damage to the machine. **DO NOT** make unauthorized modifications or alterations to this machine. Amano Pioneer Eclipse assumes no liabilities for injury or damage resulting from an unauthorized modification or alteration to the machine. Any unauthorized modification or alteration to this machine voids all warranties.

WARNING! The muffler and the engine become hot enough while the machine is in operation, and for a long time after the machine is shut off, to cause severe burns. **DO NOT** touch these parts of the machine until they have cooled.

WARNING! Injury can occur to the eyes and body while using the machine. Safety goggles, safety shoes, and safety clothing are recommended while operating the machine.

WARNING! Continuous exposure to high noise levels can cause hearing loss. Hearing protection is recommended while the machine is in operation.

WARNING! Machine vibration may cause tingling or numbness in the fingers or hands. Gloves are recommended to reduce machine vibration. If tingling or numbness persists, shut off the machine. If the vibration is caused by loose parts, adjust or tighten these parts before using the machine again.

WARNING! DO NOT engage clutch to rotate brushes unless they are in contact with floor. This can damage the brushes and/or the deck.

WARNING! DO NOT operate machine on a dry floor, as this may result in damage to the brush and/or the deck.

CAUTION! A dirty engine filter can cause overheating. Check and replace following recommended maintenance schedule.

CAUTION! Overheating can be caused by insufficient or low oil. Check oil before each use, and fill or change as needed.

CAUTION! Never over-fill engine with oil. Over-filling could cause irreparable damage to the engine.

CAUTION! Overheating can be caused by dirty oil. Check oil before each use and change regularly following recommended maintenance schedule.

CAUTION! Do not engage starter for more than 5 seconds. Allow a 10 second cool-down period for second failed start-up attempt.

CAUTION! Perform all recommended scheduled maintenance. Regular maintenance of your propane powered floor machine is necessary to keep it in safe working condition.

CAUTION! DO NOT operate machine unless trained and authorized. **DO NOT** operate machine unless you have read and understand the operation manual. **DO NOT** operate machine in flammable or explosive areas.

CAUTION! Before starting machine ensure all safety devices are in place and functioning properly. Before starting machine check for proper operation.

CAUTION! When using machine, go slowly on inclines or slippery surfaces. Use care when operating machine in reverse.

CAUTION! When servicing machine, stay clear of moving parts. **DO NOT** wear loose clothing when working on machine. Block machine wheels before raising or jacking up machine. Use hoist stands that will support the weight of the machine. Wear eye and ear protection when using pressurized air or water. Disconnect battery connections before servicing machine. Use only replacement parts supplied by Amano Pioneer Eclipse or a Amano Pioneer Eclipse Authorized Distributor or Service Center.

CAUTION! When loading or unloading machine onto or off a truck or trailer, turn machine OFF. Only use a truck or trailer that will support the weight of the machine to transport. **DO NOT** push the machine onto or off a truck or trailer unless the load height is 15 in (380mm) or less from the ground. Block machine wheels when transporting. Tie the machine down securely to truck or trailer when transporting.

CAUTION! DO NOT allow the machine to operate without moving. It may damage the floor covering.

This machine is manufactured for commercial use only

This machine is designed and manufactured to grind and polish hard floor surfaces. In addition, this machine can be used in commercial floor stripping. Amano Pioneer Eclipse does not recommend use of the machine in any environment other than an indoor environment. This machine is designed to grind and polish most modern hard floors including concrete, stone, marble, and terrazzo. It also can strip most modern types of flooring including composition tile, stone, marble, terrazzo, concrete, and resilient floor covering. Even though NFPA 11.13.2.3 says...."the use of floor maintenance machines in buildings frequented by the public, including the times when such buildings are occupied by the public, shall require the approval of the authority having jurisdiction." Amano Pioneer Eclipse suggests usage when occupancy of a given work area is minimal.

These machines should not be used...

- In nursing homes, hospitals, day-care centers, etc. that are occupied.
- By unqualified or untrained personnel.
- Unless properly maintained and adjusted.
- On areas with obstructions such as thresholds, floor outlet boxes, etc.
- In areas where loose debris or other objects are present.
- In rooms and areas without proper ventilation.

Refueling and Storage of Fuel Cylinders

This machine uses a 20lb (9.1kg) capacity aluminum or steel cylinder, which meets the DOT 4E240 standards. These cylinders are also listed by UL. In addition, the steel cylinder meets European TPED specifications and is CE compliant. Filling should be done **ONLY** by a qualified propane dealer. **FILL THROUGH THE SERVICE VALVE ONLY.** A properly filled cylinder should not exceed 80% of the rated capacity.

DO NOT attempt cylinder repair. Return the cylinder to your propane dealer if repair is necessary. Please note that DOT regulations prohibit shipping of cylinders after the cylinder has been filled with propane. When not in use, cylinders should always be stored outside in an upright position in a secure, tamper-proof, steel mesh storage cabinet. The cabinet may be located next to the building, but with at least five feet (1.5 m) of space between the cabinet and the nearest building opening (door or window).

The cylinder to be used on this machine is a vapor withdraw cylinder. **A liquid withdraw cylinder is not to be used with this machine.** The use of a liquid withdraw cylinder on a vapor withdraw system could freeze the regulator and create a fire hazard. The National Fire Protection Association (NFPA) Standard for Storage and Handling of LP Gas is the appropriate authority for safe propane use. A copy of this publication is available through the National Fire Protection Association (1-800-344-3555) or www.NFPA.org.

Operator Responsibility

The operator is responsible for performing the recommended daily maintenance and checkups of the machine to keep it in good working condition. The operator must inform the service mechanic or supervisor when recommended maintenance procedures are required as described in the "MAINTENANCE" section of this manual.

- Read this manual carefully before operating this machine.
- **FOR SAFETY: DO NOT** operate machine before reading and understanding the operation manual.
- Check the machine for shipping damage.

Keep your machine regularly maintained by following the maintenance information in this manual. Order parts and supplies only from an Authorized Amano Pioneer Eclipse Distributor. Use the parts illustration section of your manual when ordering parts. During and after operation, perform the recommended daily and hourly procedures outlined in the Maintenance Chart.

Canadian Safety Requirements

1. A sign indicating "NO SMOKING" shall be permanently displayed at the storage area. The sign shall be in accordance with the sign required in Clause 10.12.3 of CAN/CGA-B149.2-M91, Propane Installation Code.
2. When the cylinder is attached to the floor maintenance machine for use, the operator shall not leave the unit unattended except for short periods of time such as rest stops, washroom, or meal stops.
3. The requirements of 1.10.1 (e) and (g) do not apply in industrial buildings.
4. A floor maintenance machine shall only be used in buildings:
 - a. Provided with continuous mechanical ventilation that removes products of combustion to the outdoors of not less than 300 CFM for each 10,000 BTU-hr or fraction thereof.
 - b. Provided with natural ventilation of not less than 300 CFM for each 10,000 BTU-hr input or fraction thereof, based on a maximum of one-quarter-air exchange per hour for the net building volume.
5. The owner of a floor maintenance machine shall ensure that the operator has participated in a course authorized by the manufacturer of the unit on the safe handling of propane and the safe operation of the machine.
6. The owner of a floor maintenance machine shall ensure that the unit is maintained in accordance with the manufacturer's recommended maintenance procedures in a safe operating condition and the owner shall maintain a record of the maintenance for a period of two years.
7. Before transporting a floor maintenance machine, the cylinder shall be securely fastened with the system valve closed, and the cylinder shall be located in a well-ventilated space.

Exigences de sécurité pour le Canada

1. Un panneau indiquant " INTERDICTION DE FUMER " doit être affiché en permanence dans la zone de stockage. Il doit être conforme au panneau exigé par la Clause 10.12.3 du CAN/CGA-B149.2-M91, Code installation propane.
2. Lorsque le cylindre est fixé à la machine d'entretien des sols pour son utilisation, l'opérateur ne doit pas laisser l'unité sans surveillance, sauf pour de courtes périodes, notamment pour faire une pause, aller aux toilettes ou au moment des repas.
3. Les conditions du 1.10.1 (e) et (g) ne s'appliquent pas aux bâtiments industriels.
4. Une machine d'entretien des sols ne doit être utilisée que dans les bâtiments suivants :
 - a. Équipés d'un système de ventilation mécanique ininterrompu, capable d'évacuer les produits de combustion vers l'extérieur, non inférieur à 300 CFM pour chaque 10 000 BTU/h ou une fraction de ce dernier.
 - b. Équipés d'un système de ventilation naturel non inférieur à 300 CFM pour chaque 10 000 BTU/h ou une fraction de ce dernier, basé sur un maximum d'un quart d'air échangé par heure pour le volume net du bâtiment.
5. Le propriétaire d'une machine d'entretien des sols doit s'assurer que l'opérateur a participé à une formation habilitée par le fabricant de l'unité, relative à la manipulation sûre du propane et de la machine.
6. Le propriétaire d'une machine d'entretien des sols doit s'assurer que l'unité bénéficie d'un entretien conforme aux procédures de maintenance recommandées par le fabricant dans des conditions d'utilisation sûres. De plus, il doit tenir un registre de la maintenance sur une période de deux ans.
7. Avant de transporter une machine d'entretien des sols, le cylindre doit être fixé de manière sûre avec le système de soupapes fermé. De plus, il doit se trouver dans un espace bien ventilé.

Test for Operator-Ear Sound Pressure Level

Amano Pioneer Eclipse measures and rates the operator-ear sound pressure level for hand-guided floor treatment and floor cleaning machines for industrial use. All tests are performed in accordance with European Machinery Directive (2006/42/EC).

- Outdoor test area consists of a flat open space free from effects of signboards, buildings or hillsides for at least 15 m (50 ft) from the center of the test surface. Indoor tests are conducted in a semi-anechoic or sound deadening room.
- The test surface is a single sheet of floor covering at least 1 m (3.3 ft) wider and longer than the equipment being tested. In order to not affect the sound reading, the observer taking readings is at least 2 m (6.6 ft.) from the equipment being tested, or standing directly behind the operator.
- All machines are tested while stationary and centered on the test surface. With the traction drive in neutral (where applicable) the test is conducted with the machine at maximum engine or motor speed as specified by the manufacturer.
- The operator is located in the normal operating position with the microphone or meter supported independent of the machine, 1,68 m (66 in) above the test surface, 25 cm (10 in) to the right and left centerline of the operators position, and 20 cm (8 in) to the rearmost point of the handle, with the handle in the most forward position.
- The sound level meter is observed for a minimum of 5 seconds or until a stabilized reading is obtained. The maximum repeatable sound level observed during the test at each microphone position is recorded and documented.

Test for Hand-Arm Vibration at the Grip Surface of Hand-Guided Machinery

Amano Pioneer Eclipse measures and rates the vibration at the machine-hand contact surface of hand-guided machines that are provided with handles in accordance with European Machinery Directive (2006/42/EC).

- The test area consists of a flat open floor area that allows the machine to be operated normally.
- The transducer is mounted firmly at a point halfway along the length of the handle where the handle would normally be held.
- Machines are tested while stationary, with all mechanisms necessary for the equipment to perform its intended functions engaged and the traction drive in neutral (if applicable). The machine will be tested at maximum engine or motor speed as specified by the manufacturer of the subject machine.
- The measurements are recorded from the dominant axis.

Machine Preparation

Unpacking the Machine

The machine is shipped boxed on a wooden pallet. To unpack machine:

1. Cut and remove bands holding the box to the pallet.
2. Remove staples attaching the box to the platform at the bottom edge of the box.
3. With two people, one at either end of the box, lift box straight up and off machine.
4. Cut and remove bands securing the machine to the pallet.



5. Remove all bracing.
6. Remove T-handle and drivers from pallet.
7. Check machine engine oil (See *Maintenance* section).

NOTE: If machine was shipped by airfreight, add engine oil.

8. Place a ramp on or against the pallet to prevent the machine from dropping off the pallet and causing damage.
9. Rock the machine back by pushing down on one of the foot pegs while pulling back on the handle.
10. Carefully back the machine off the pallet.

Filling the LP Cylinder

This machine uses the 20 lb (9.1 kg) capacity cylinder, which meets the D.O.T. 4E240 standards. These cylinders are also listed by UL. In addition, the steel cylinder meets European TPED specifications and is CE compliant. Filling should be done **ONLY** by a qualified propane dealer. A properly filled cylinder should not exceed 80% of the rated capacity. Do not overfill the cylinder or use a liquid withdraw cylinder on the machine. The use of a liquid withdraw cylinder on a vapor withdraw system could freeze the regulator and create a fire hazard.

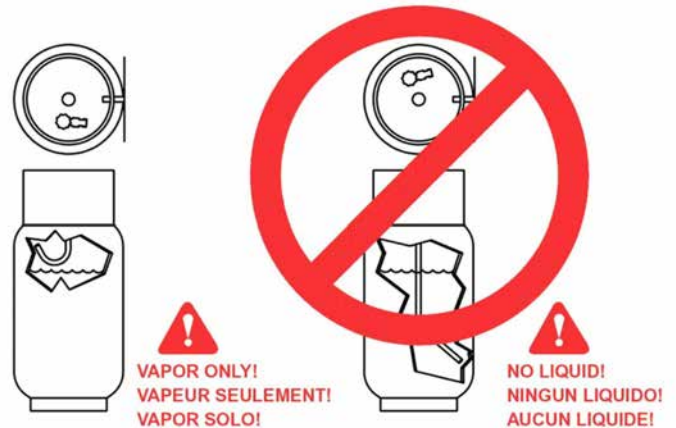

Installing the LP Cylinder

Place the cylinder on the cylinder platform at the back of the machine. Connect the fuel hose coupling to the service valve by turning to the right (clockwise). **HAND TIGHTEN ONLY!** Make sure coupling is not cross threaded and check for leakage by noting any propane odors immediately after cylinder is connected. Finally, secure the tank to the machine using the adjustable strap. Remove slack by pulling on the loose end and securing with the Velcro.

TO REMOVE THE LP CYLINDER, reverse the above procedure. Always connect or change cylinders in a well-ventilated area.

Machine Components

Controls and Instruments

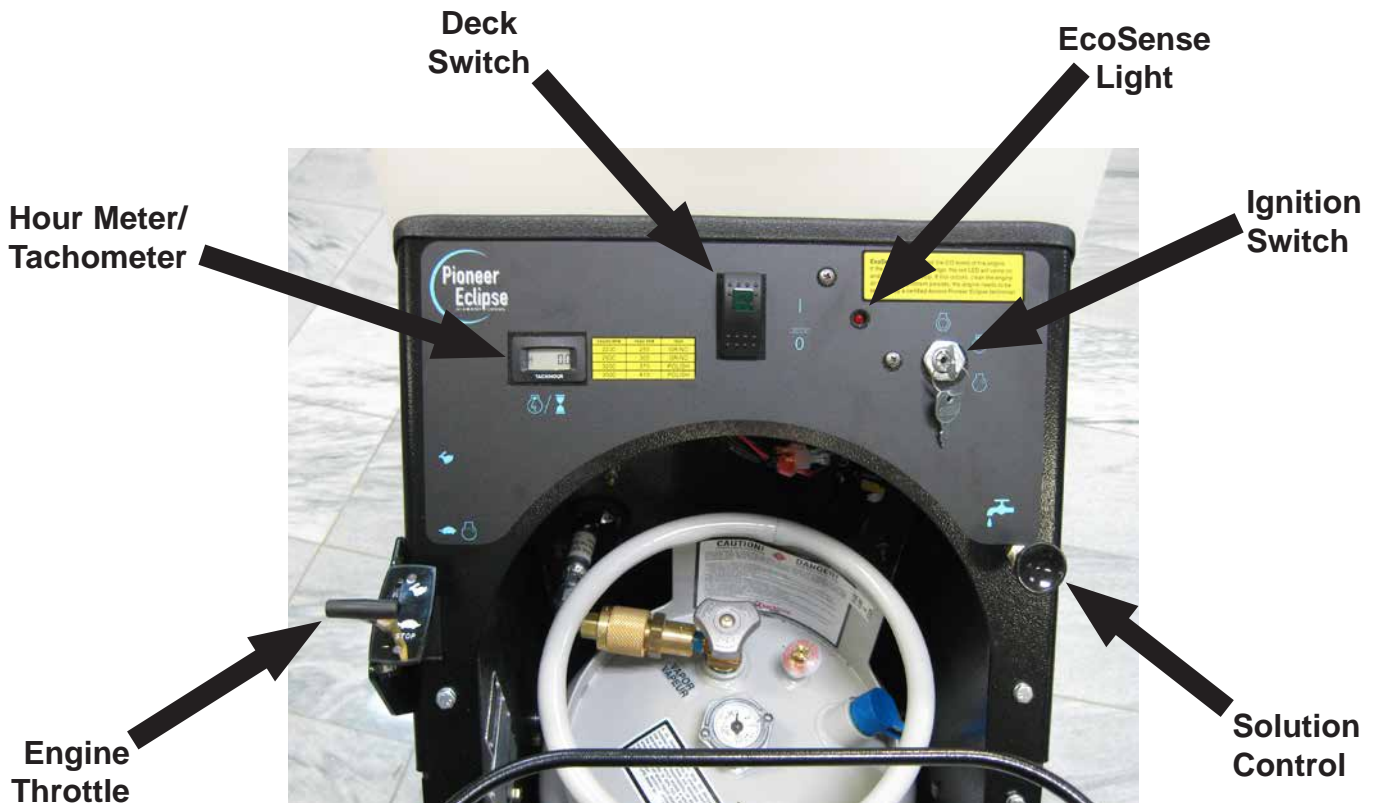

Ignition Switch

This machine features a key switch ignition.

Start: Turn the key all the way clockwise or START to engage the engine starter motor. Once the engine starts release the key.

NOTE: Always start this machine with the engine throttle in the idle or “slow” position.

Run: This is the position of the key while the engine is running.

Off: Turn the key to the “OFF” position to stop the engine from running.

NOTE: For safety, always close the propane cylinder valve to stop the engine and then turn the key switch to the “OFF” position.

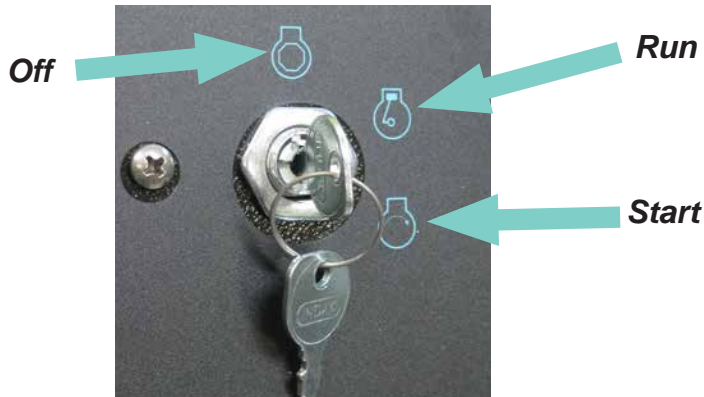

Hour Meter / Tachometer

The hour meter / tachometer records the number of hours the machine has been powered ON. The hour meter reading is used to mark recommended maintenance intervals. It also displays the engine speed. This meter displays hours when the machine is turned OFF and engine speed when the machine is turned ON.



Safety Bail

The safety bail must be pulled back in order for the clutch to be engaged and the deck heads to rotate.

Engage: Press the top of the deck switch and pull the safety bail back.

Disengage: Release the safety bail and press the bottom of the deck switch.



Engine Throttle

The engine throttle controls the engine speed. To increase engine speed, move the hand lever forward. For idle position, pull the lever back.



Solution Control

The solution control cable controls the solution flow to the floor.

Increase Flow: Pull the knob outward.

Decrease Flow: Push the knob inward.

Stop: Push the knob all the way in.

NOTE: Even if the ignition switch is in the “OFF” position, solution can still be dispensed on the floor. Take care to push the knob in when the machine is not in use.



EcoSense Emission Monitoring System

EcoSense is an emissions monitoring device that monitors the exhaust emissions and will shut the engine down if the emissions levels are too low or too high.



The monitor must receive a signal from the oxygen sensor in order to function. If it did not have a minimum reading requirement it would be possible to disconnect the oxygen sensor and operate the unit, even if the emissions were out of limits. In order for the unit to work as designed it must be able to read both low and high signals, with “not to exceed limits” of both.

The oxygen sensor must reach operating temperature before it will start to send signals to the EcoSense module. This time is set at one minute. A unit may shut down at a cold start up after one minute because the oxygen sensor did not reach required temperature to start to send signals. If this happens, turn the key to the off position several seconds to clear the EcoSense module and restart the engine. Once the engine has started, advance the throttle to full throttle position and start the operation. With the engine at full throttle under load, the signal from the oxygen sensor should be within the normal operating ranges for safe operation.

If the engine's air intake filter needs to be serviced, or an over-filled cylinder has been installed by mistake, or there is a problem with the fuel system that causes the oxygen sensor's signal to be out of range, EcoSense will shut the unit down in four minutes. The unit can be re-started after clearing the module by turning off the key switch. If corrections have not been made to the unit, EcoSense will continue to shut the unit down after the one minute warm-up and/or four minute out of limit periods.

Engines tend to go to lean burn if allowed to idle for even short periods. Even at high idle speeds most engines will continue to lean downward. It is always best to shut the engine off when it is not being used to do work. Remember the engine is always creating emissions as long as it is running.

The best manner to operate a unit equipped with EcoSense is as follows.

1. With the throttle in the slow position, turn the key switch to the start position, once the engine starts, advance the throttle to full throttle “fast”.
2. When ready to stop operation, release clutch (if equipped) and move throttle to the slow position. If the unit will not be used within one minute, turn the key switch to the off position. If the unit will not be returned to service within a few minutes it is best to turn the gas valve on the tank off first and let the engine consume all fuel that is in lines. Once the engine dies, turn the key switch to off position.

3. When ready to restart, open the gas valve on the tank, put the throttle in slow position and turn key switch to the start position. Once the engine has started, move throttle to full position and return to operation.

SAFR™ technology monitors the pressure between the air filter and the carburetor. As the air filter becomes dirty, this pressure decreases. With **SAFR™** technology, this change in pressure results in a reduction in fuel delivered to the engine. The net result is a Steady Air Fuel Ratio regardless of the air filter condition.

Deck Switch

The deck switch energizes the clutch, allowing the heads to turn when the safety bail is engaged.

Engage: Press the top of the switch. The green light is ON.

Disengage: Press the bottom of the switch. The green light is OFF.



NOTE: The safety bail must be pulled back for the clutch to engage.

Handle Pivot Knob

To move or adjust the operators handle, loosen the handle pivot knobs on both side of the bulkhead. The handle pivot knobs must be tightened before operating, moving, or tilting the machine back to access the drivers.



Handle Adjustment / Position

To adjust the operating position of the handle, simply loosen the two handle pivot knobs, slide the handle to the desired position and tighten the two handle pivot knobs.

1. To place the handle in the Head Change Position, loosen the handle pivot knobs so the handle can slide.
2. Pull the handle out until it stops.
3. Rotate handle towards the front of the machine until it is vertical.
4. Push downward on the handle until it stops.

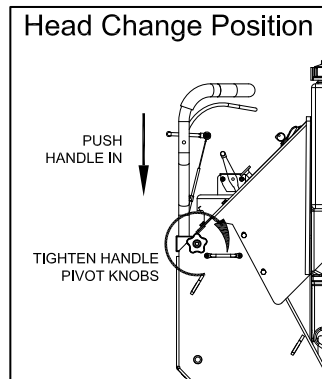
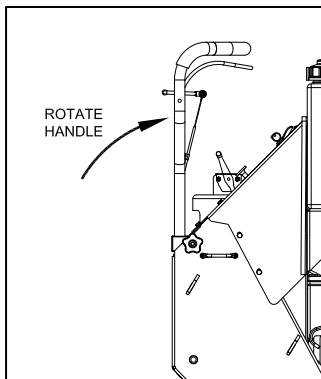
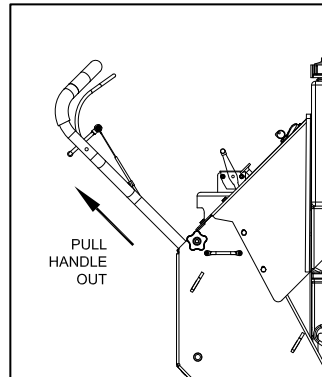
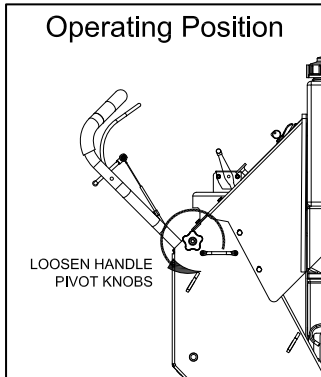

Fuse

The machine's electrical circuit is protected by a fuse, which stops the flow of current in the event of a circuit overload. Once a fuse blows, it must be replaced. If the overload that caused the fuse to fail is still present, the new fuse will fail and the problem must be corrected. **DO NOT** bypass any fuse. The ignition fuse is located on the under side of the bulkhead control panel.

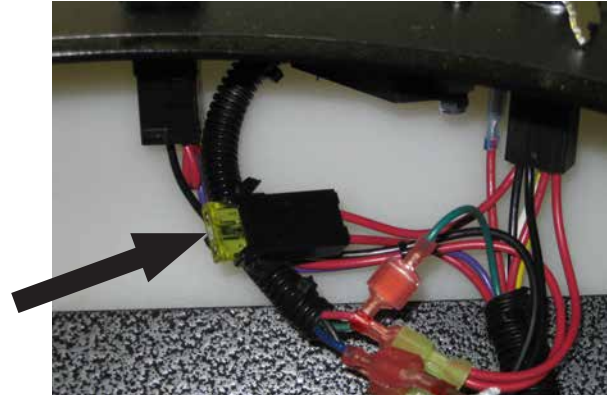

Solution Tank

Filling the Solution Tank:

1. Push the machine to a level water filling station.
2. Turn the propane cylinder service valve clockwise to close. When the engine has stopped, turn the ignition switch to the "OFF" position.
3. Remove the solution tank lid.



4. Fill the solution tank with water. Capacity: 9 US Gal (34.1L)

Head Change

1. Close the valve on the propane cylinder, allow the engine to stop and turn the machine OFF.
2. Place the handle in the head change position (see *Handle Adjustment / Position* section).
3. Rock the machine back by pushing down on one of the foot pegs while pulling back on the handle.



4. Gently allow the bottom side of the control panel to rest on the floor.

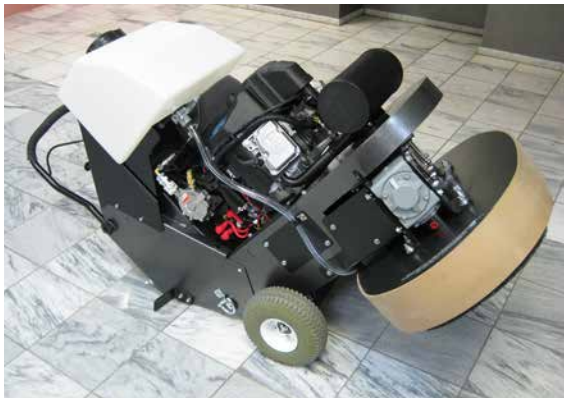

5. Check the front of the machine to be sure it is stable and not going to fall back to the floor.
6. If the grinding / polishing heads are being used and pull each diamond disk off their respective holder.



NOTE: A flat screwdriver may be required to pry off the diamond disk.

7. If it is necessary to remove or replace the head, each head can be removed by rotating toward the center of the machine. Facing the machine from the front, turn the head on the right counter-clockwise with a quick motion and pull the head towards you. Turn the head on the left clockwise with a quick motion and pull the head towards you.



CAUTION! Carefully inspect all head assemblies for cracks or damage. Replace if necessary.

WARNING! A damaged head rotating at high speeds may be an extreme hazard if it should come apart.

8. To install a head on the right side, facing the machine from the front, align the three lugs with the three slots and turn clockwise with a quick motion. Make sure that the head assembly has properly snapped into place before releasing.
 9. To install a head assembly on the left side, facing the machine from the front, align the three lugs with the three slots and turn counter-clockwise with a quick motion. Make sure that the head assembly has properly snapped into place before releasing.
 10. Verify that all three lugs of both head assemblies are correctly installed. If all three lugs are not properly installed, it is possible that the assembly could come loose from the machine. This may also cause damage to the machine and/or floor.
- NOTE:** In a grinding or polishing application it is very important that all three lugs of each head are correct. If a lug is out of place, the head could cause uneven diamond wear and/or damage the floor.
11. This machine is compatible with pad drivers, brushes, and other various type heads. Consult the "Machine Options" section of this manual for more information.

How the Machine Works

This machine is a propane hard floor machine. It has two counter-rotating heads that are bevel gear driven via a clutch and belt. The clutch is controlled by a switch on the control panel and a safety bail on the handle. The polishing heads are designed to accommodate a variety of 3" diamond disks to polish concrete, marble, or terrazzo. The machine can also utilize brushes and pads.

Pre-Operation Checklist

- Check the engine oil level. Add oil if needed. Refer to *Maintenance*.
- Inspect the engine dust filter and clean off any debris or dust buildup. Refer to *Maintenance*.
- Inspect the engine carburetor air filter. Clean or replace if needed. A dirty air filter could lead to elevated levels of carbon monoxide. Refer to *Maintenance*.
- Inspect the counter-rotating heads and their attachments. Make sure there are no signs of damage or loose parts. Refer to *Maintenance*.

WARNING! A DAMAGED ROTATING DISK (HEAD), ROTATING AT HIGH SPEEDS MAY BE AN EXTREME HAZARD IF IT SHOULD DISINTEGRATE OR BECOME LOOSE FROM THE MACHINE.

- Inspect the drive belt. Replace if necessary. Refer to *Maintenance*.
- Check the machine for leaks or loose fasteners.

LP Fuel Cylinder

This machine uses the 20 lb (9.1 kg) capacity cylinder, which meets the D.O.T. 4E240 standards. These cylinders are also listed by UL. In addition, the steel cylinder meets European TPED specifications and is CE compliant. Filling should be done ONLY by a qualified propane dealer. A properly filled cylinder should not exceed 80% of the rated capacity. Do not overfill the cylinder or use a liquid withdraw cylinder on the machine. The use of a liquid withdraw cylinder on a vapor withdraw system could freeze the regulator and create a fire hazard.

Only Use a Vapor Cylinder!



Installing the LP Cylinder

1. Before bringing a propane cylinder indoors, always check it for over-filling.

CAUTION! Always connect or change cylinders in a well ventilated area.

2. Place the tank on the machine and secure with the retaining strap. Remove slack by pulling on the loose end of the strap and secure back to strap. Connect the fuel hose coupling to the service valve by turning clockwise. "HAND TIGHTEN ONLY." Make sure coupling is not cross threaded and check for leakage by noting any propane odors immediately after cylinder is connected. (It is sometimes easier to install if the connection to the service valve is made before strapping the cylinder in place.)



CAUTION! Always open service valve slowly to allow pressure to equalize in hoses. Opening quickly may cause the flow check valve to engage, limiting fuel flow.

3. To remove the cylinder, reverse procedure.

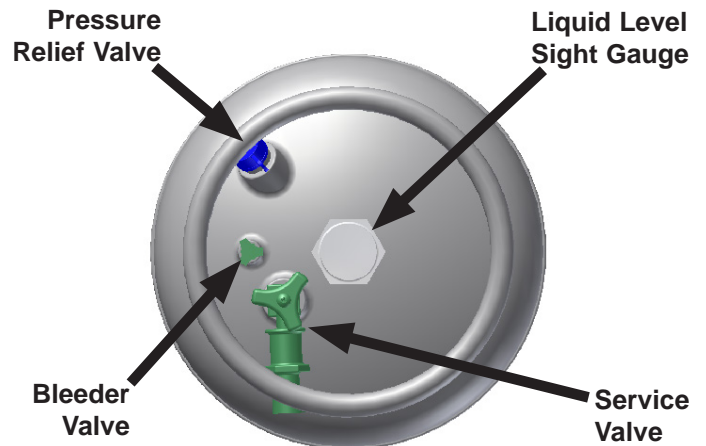

Starting the Machine

1. Check oil and fuel levels.
2. Check and clean engine dust filter.

CAUTION! Never run continuously for more than 1 hour without cleaning or changing engine dust filter.

3. Check carburetor air filter. Change if necessary. (See “Scheduled Maintenance”)
4. Turn propane service valve counterclockwise to open.

CAUTION! Always open service valve slowly to allow pressure to equalize in hoses. Opening quickly may cause the flow check valve to engage, limiting fuel flow.

5. With the engine throttle lever in the idle position, engage the starter by turning the ignition switch to the starting position for approximately 5 seconds. If the engine does not start, release the ignition switch for 10 seconds, then try to start again in another 5 seconds.
6. After the engine has started, move the throttle forward approximately halfway and allow the engine to warm up for approximately 30 seconds.

WARNING! Catalytic mufflers require a few minutes to warm up before effectively removing harmful emissions. Make sure of proper ventilation during this warm-up period!

Idling and Stopping the Machine

DANGER! Allowing the engine to idle excessively will increase carbon monoxide emissions!

To stop the engine, close the service valve on the fuel cylinder by turning it clockwise (the engine will stop when the fuel in the lines is used up). Once the engine stops, turn the ignition switch off.

Post Operation Checklist

- Turn off the LP cylinder service valve. When the fuel is depleted and the engine stops, turn the key switch OFF.
- Remove the heads from the machine and clean both the heads and the machine.
- Check under the machine for leaks and loose fasteners.

Work Site Transporting

1. Close the valve on the propane cylinder, allow the engine to stop and turn the machine OFF.
3. Place the handle in the head change position (see Handle Adjustment / Position section).
4. Rock the machine back by pushing down on one of the foot pegs while pulling back on the handle.



5. Push the machine around on the two rear wheels.

WARNING! Use extreme caution when going up and down inclines because the machine is very heavy. When transporting the machine up or down an incline, help may be required.

Operating the Machine

1. Inspect the area in which the machine is going to be used. Remove any loose debris, objects, or standing studs from the floor.

WARNING! If the counter-rotating heads come in contact with loose objects or standing studs, they could throw objects or diamond disks into other objects or people.

2. Place appropriate heads on the machine and operate according to the application (see *Head Change* section).



CAUTION! Keep the machine moving when the heads are rotating. Failure to do this may result in floor damage.

NOTE: To not comply with any of the **CAUTION!** statements could cause the engine to overheat and/or damage the drive components.

3. When operation is complete, push the machine to the desired location. Turn off the LP cylinder service valve. When the fuel is depleted and the engine stops, turn the key switch OFF.
4. Remove the LP cylinder and store properly. Refer to Refueling and Storage of Fuel Cylinders.

Splash Skirt

1. The skirt should be removed after each use and cleaned.
2. To remove the skirt, turn the machine off, and place the machine in the head change position.
3. The skirt can be removed by pulling it off of the deck.



4. To re-install the skirt, start in the back and stretch the skirt over the perimeter of the deck. Be sure the slot in the skirt is in the center of the deck and facing forward.



5. When the bottom edge of the skirt is worn, the skirt can be removed and flipped over to provide a new wear edge.
6. When the machine is lowered back to the operating position, push down on the top perimeter of the skirt so it will conform to the floor.

Machine Troubleshooting

Problem	Possible Cause	Solution
Engine is hard to start	Propane cylinder is not properly connected.	Check connection and open service valve slowly.
	Battery is weak.	Charge battery or replace.
	Oil level is to low.	Check the oil level and add if needed.
	Insufficient vacuum.	Place the engine throttle in the idle "slow" position.
		Check the regulator vacuum hose for breaks, pinched hose, or a bad connection.
	Coil air gap out of adjustment.	Adjust coil air gap (Check FX481V Service Manual). Contact an APEC Certified Technician.
	Clutch is engaged	Release safety bail and turn off the deck switch
	Spark plug or head bolts loose.	Retorque (Check FX481V Service Manual). Contact an APEC Certified Technician.
Head gasket blown or valves need adjusting	Replace head gasket, adjust valves and replace if necessary (Check FX481V Service Manual). Contact an APEC Certified Technician.	
Engine will not start	Propane cylinder is empty.	Install properly filled cylinder.
	Oil level is to low.	Check the oil level and add if needed.
	Propane cylinder is not properly connected.	Check connection and open service valve slowly.
	Main fuse is blown.	Inspect fuse and if blown replace.
	Insufficient vacuum.	Place the engine throttle in the idle "slow" position.
		Check the regulator vacuum hose for breaks, pinched hose, or a bad connection.
	Head gasket blown or valves need adjusting	Replace head gasket, adjust valves and replace if necessary (Check FX481V Service Manual). Contact an APEC Certified Technician.
	Wires broken or disconnected.	Reconnect or replace wires. Contact an APEC Certified Technician.
	Coil(s) defective.	Replace coil(s) (Check FX481V Service Manual). Contact an APEC Certified Technician.
	Spark plug gap is incorrect.	Adjust gap to 0.025" (.64mm)
Spark plug defective.	Replace spark plug.	
Engine lacks power	Propane cylinder has air in it	Properly purge cylinder.
	Propane cylinder overfilled or liquid withdrawl.	Install properly filled cylinder.
	Fuel filter is clogged	Replace fuel filter in the fuel lock-off.
	Dirty air filter.	Clean or replace the air filter element.
	Governor out of adjustment or malfunctioning.	Adjust governor and replace if necessary (Check FX481V Service Manual). Contact an APEC Certified Technician.
	Head gasket leaking.	Replace head gasket (Check FX481V Service Manual). Contact an APEC Certified Technician.
	No compression.	Worn piston ring(s) and/or cylinder head(s) require replacement (Check FX481V Service Manual). Contact an APEC Certified Technician.
	Fuel mixture is to lean.	Check and adjust fuel mixture if necessary. Contact an APEC Certified Technician.
	Throttle out of adjustment.	Make sure throttle will go wide open.
	Valves need adjusting or replacing.	Adjust valves (Check FX481V Service Manual). Contact an APEC Certified Technician.
Smell or burned rubber	Belt out of adjustment.	Check the automatic tensioner
Machine vibrates	Loose fasteners.	Check the engine, tensioner, spindle, and pad holder fasteners. Tighten any fasteners that may be loose.
	Heads not installed correctly.	Remove head and install properly. Check for cracks or loose hardware. Replace if necessary.
Engine stops running	Propane cylinder is empty.	Install properly filled cylinder.
	Engine oil level is to low.	Check the oil level and add if needed.
	Dirty air filter.	Clean air filter and replace if necessary.
	EcoSense shut the machine down.	Check SAFR signal line.
		Clean air filter and replace if necessary.
Check for any loose wiring or fuel line connections.		
Service machine and check the fuel settings. Contact an APEC Certified Technician		
Machine is too aggressive	Operator is walking too slow.	Operate at faster walking speed.
	Inappropriate attachment for application.	Change attachment.
Clutch will not engage	Loose Connection.	Check all of the wiring for a bad connection or broken wire.
	Deck Switch is not on.	Press the deck switch and pull the safety bail back.
	Clutch is bad.	Replace clutch if necessary. Contact an APEC Certified Technician.
Head(s) are not rotating.	Shear Pin has broke.	Replace Shear Pin

Maintenance

Scheduled Maintenance

Operation	Interval							
	Daily	First 8 Hrs.	Every 50 Hrs.	Every 100 Hrs.	Every 200 Hrs.	Every 300 Hrs.	Every 400 Hrs.	Every 500 Hrs.
Check & add engine oil	●							
Check for loose or lost fasteners	●							
Check for oil leakage	●							
Inspect fuel hose and connections	●							
Clean engine dust filter	●							
Inspect Head Asm; Brush; & Pad Driver	●							
Change engine oil		●	●					
Change engine oil filter		●		●				
Check & clean air cleaner	●							
Inspect battery and battery connections				●				
Replace air cleaner			●					
Inspect, clean, & re-gap spark plugs, Replace if necessary				●				
Check & adjust valve clearance.* Retorque heads.*						●		
Clean & lap valve seating surface.*						●		
Check engine emissions*								●
Clean cooling fins			●					
Inspect drive belt				●				
Inspect gear box assembly				●				
Check gear box(s) oil level				●				
Change oil in gearboxes	First 500 hrs., Then every 2500 hrs.							
Replace drive belt	As Required							
* Check FS481V / FX481V Service Manual. Contact Amano Pioneer Eclipse Certified Technician.								

Air Filter Inspection and Replacement

1. Push machine to a level surface.
2. Turn off LP Cylinder valve and remove from the machine.
3. Turn the two knobs 1/4 turn counter-clockwise and remove the filter cover.



4. Loosen clamp that retains filter and remove the air filter.

CAUTION! DO NOT wash the air filters. DO NOT oil the air filters. DO NOT use pressurized air to clean the air filters.

5. Inspect both primary and secondary air filters. If necessary, clean primary filter by lightly tapping and wipe seal ends with a clean cloth. If primary filter cannot be cleaned, is bent, or damaged, it must be replaced (**Part #: KA110130752**).
6. If secondary filter is dirty, do not attempt to clean it. Replace it with a new filter (**Part #: KA110137046**).
7. Check the intake hose for cracks or damage.
8. Install the filters and replace cover.

Engine Dust Filter

1. The engine dust filter should be cleaned each hour and after each use by shaking out the dust and then rinsing with mild detergent. The filter can also be vacuumed with a wet-dry vacuum.
2. Squeeze out the excess water (*Do Not Wring*).
3. Allow the filter to air dry.

NOTE: Failure to maintain a clean engine filter will cause the engine to overheat. Also, it may cause the exhaust emissions to elevate to harmful levels. If necessary, replace with (**Part #: MP371300**).



Inspect Fuel Hose and Connections

1. Push machine to level surface.
2. Turn off LP cylinder and remove it.
3. Inspect hoses for abrasions and other signs of wear. Replace all worn or damaged hoses.
4. Check for gas leaks by spreading a soapy water solution around all connections while the LP cylinder is reconnected and the service valve is turned ON.



5. If a leak is detected, turn off the LP cylinder. If the leak is in a hose, replace it. If the leak is at a fitting, loosen and clean it. Apply pipe-sealing compound and re-tighten it.
6. Recheck for leaks using a soapy water solution. If leaks persist at fittings, replace them and recheck with a soapy water solution once more.

Oil Level Inspection

1. Push machine to level surface.
2. Turn off LP cylinder and remove it.
3. Clean area around the oil gauge before removing it.
4. Remove the oil gauge and wipe it with a clean cloth.
5. The machine should be in an upright level position.



6. Insert the oil gauge into the tube, but do not tighten the oil gauge.
7. Check the oil level. It should be between the "FULL" and "ADD" marks on the oil gauge.

NOTE: If the oil level is near or below the "ADD" mark, remove the oil gauge and add enough engine oil to bring oil level to the "FULL" mark. (Use only SH or SJ SAE30 Oil)

NOTE: If the oil level is too high, remove the excess oil by loosening the oil drain valve.

CAUTION! Do not fill above the "FULL" mark. Excess oil will cause a smoking condition and may cause the engine to overheat.

Oil Change

1. Change the oil after the first 8 hours of operation and every 50 hours thereafter.
2. Start and warm the engine so the oil will drain easily and completely. Push machine to a level surface. Stop the engine.
3. Turn off LP cylinder and remove it.
4. Locate the drain hose underneath the bulkhead compartment. Remove the cap on the end of the oil drain hose.



5. Place a suitable container under the end of the oil drain hose.

WARNING! Be careful with hot oil being drained. It may be hot enough to cause severe burns.

6. Slowly turn the valve counter-clockwise, until the oil starts to drain.



NOTE: In order for the oil to drain, it may be necessary to loosen the oil fill cap.

7. When the oil has finished draining, close the drain valve and place cap back on the end of the valve.
8. Remove oil cap and add clean SH or SJ SAE 30 oil. Use 1.6 U.S. qt. (1.5 L) when the filter is not changed and 1.8 U.S. qt. (1.7 L) when filter is changed.
9. Screw in oil gauge. Reconnect the LP cylinder to the fuel hose.
10. Run the engine at low idle for 2 minutes. Check for leaks around the engine.
11. Stop the engine. Check the oil level (see *Oil Level Inspection* section).

Oil Filter Replacement

1. Place a suitable container underneath the oil filter.
2. Using a strap wrench or oil filter wrench, remove the oil filter. Turn the filter counter-clockwise to remove it.
3. Apply a thin coat of new oil or grease to the oil filter seal (-B-).
4. Install the new filter (-A-) (**Part #: KA490657007**) by turning it clockwise.
5. Turn the filter until the seal contacts the mounting surface (-C-) of the engine. Then, turn the filter "BY HAND" 3/4 turn more.

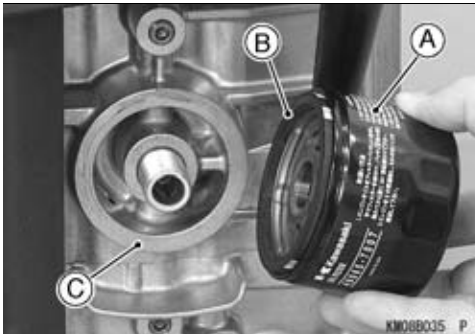

6. Reconnect the LP cylinder to the fuel hose.
7. Run the engine at low idle for 2 minutes. Check for leaks around the engine.
8. Stop the engine. Check the oil level (see *Oil Level Inspection* section).

Spark Plug Inspection and Replacement

1. Turn off LP cylinder and remove it.
2. Pull spark plug cap off of spark plug.
3. Remove spark plug by turning counter-clockwise and inspect it.

NOTE: If the plug is oily or has carbon build up on it, clean the plug using a high flash-point solvent and a wire brush or other suitable tool.

NOTE: If the spark plug electrodes are corroded or damaged, or if the insulator is cracked, replace the plug. Use Only Part # KA920702112. DO NOT use any other spark plug!

4. Measure the gap with a wire-type thickness gauge. The correct gap is .025 in (.635 mm). If the gap is incorrect, carefully bend the side electrode with a suitable tool to obtain the correct gap.

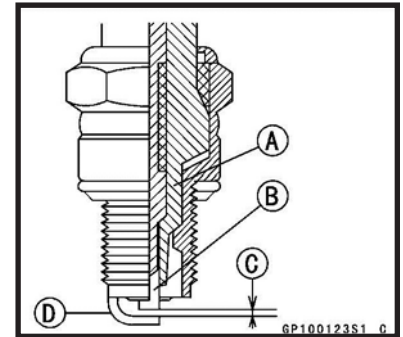

- A: Insulator
- B: Center Electrode
- C: Plug Gap
- D: Side Electrode

Valve Clearance & Re-torque Heads:

Refer to Kawasaki's FS481V service manual.

Valve Seating:

Refer to Kawasaki's FS481V service manual.

Head Bolt Maintenance

Refer to Kawasaki's FS481V service manual.

Cooling Fin Maintenance

- A. Remove blower housing and any other shrouds.
- B. Clean the cooling fins as necessary using compressed air or pressure washer.
- C. Reinstall all housings and shrouds.

Inspect Drivers / Pad Holders

1. Push machine to level surface.
2. Turn off LP cylinder and remove it.
3. Place the machine in the Head Change position (See *Head Change* section).
4. Inspect Head Assemblies/Brushes for loose bolts, cracks, and wear. It is recommended that brushes be replaced when bristles are worn to 1/2" (1.3cm) length.

WARNING! A damaged driver, brush, or pad holder rotating at a high rate of speed may be an extreme hazard if it should come apart.

Belt Maintenance

1. Push machine to a level surface.
2. Turn off LP Cylinder and remove it.
3. Remove all of the weights from the front of the machine.
4. Remove the pulley cover from the machine. There are two bolts on top in front of the engine. There are two on the underside of the cover on the backside of the gearboxes. There are two more on the underside of the pulley cover in front of the gearboxes.

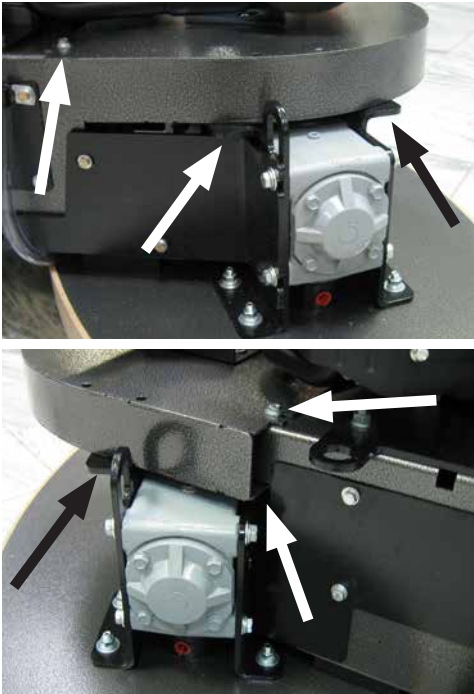

5. Place the machine in the head change position.
6. Rotate the head assemblies and inspect belt.
7. If cracks or excessive wear is present, the belt needs to be replaced.
8. To check for proper tightness, push inward on the belt. The belt should deflect between 1/4" (0.6 cm) and 1/2" (1.3 cm).

To Change Belt:

Part #: MP273000

1. Push machine to a level surface.
2. Turn off LP Cylinder and remove it.
3. Remove all of the weights from the front of the machine.
4. Remove the pulley cover from the machine. There are two bolts on top in front of the engine. There are two on the underside of the cover on the backside of the gearboxes. There are two more on the underside of the pulley cover in front of the gearboxes. (See *Belt Maintenance*)
5. Remove the frame access panel on the right side of the machine.

6. Remove one of the clutch retainer brackets, allowing the bottom of the clutch to turn.

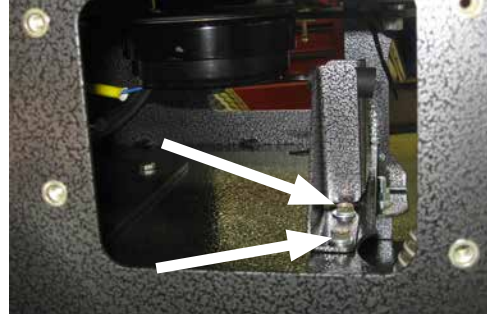

7. Place the machine in the head change position.
8. Remove the belt by slipping it off the center gearbox pulley. Turning the head assembly will make it easier to remove belt from the pulley.



9. Lower the machine back to the floor in the operating position.
10. Locate the clutch wiring harness and disconnect the plug. Pull harness through engine mounting plate. Cut the cable tie securing harness to frame.
11. Loosen bolt that fastens tensioner body to bracket. This will allow the belt to be removed from the tensioner.
12. Remove old belt from the machine.
13. With the belt removed, check the fasteners and condition of all the drive components.
14. Install new belt, routing it around the clutch pulley, tensioner pulley, and through front of frame.
15. Tighten tensioner bolt.
16. Using the large diameter pulley on the head assembly, rotate the pulley until the belt snaps into place.
17. Using the head assembly pulley, turn the drive components. Check for any interference and proper tightness.
18. Route clutch harness back through engine plate and re-connect. Replace cable tie to secure harness to frame.
19. Reattach the frame access panel and the pulley cover.

CAUTION! DO NOT run the machine without covers installed.

Shear Bolt Replacement

1. Push the machine to a level work surface.
2. Turn the LP Cylinder off and remove it from the machine.
3. To replace a shear pin, place the machine in the head change position (See *Head Change* section).
4. Determine which head drive assembly has a broken shear pin by turning the head assemblies with your hands.
5. Remove the cover plate on the front of the gearbox support brackets to expose the shear coupling.

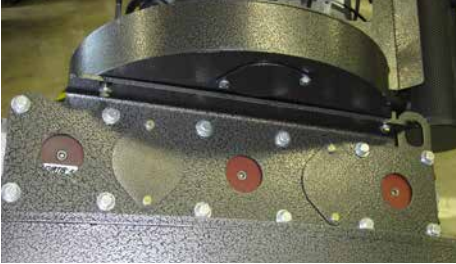

6. Remove any remaining pieces of the shear bolt that failed.
7. Turn the head assembly until the holes in the gearbox shaft align with the hole in the shear coupling.
8. Install a new shear bolt. (**Part #: SA029400**)
9. Replace cover plate.

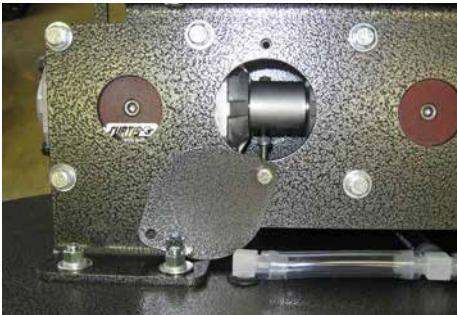

Battery Maintenance

The battery supplied with this machine is a sealed, absorbed glass mat (AGM), maintenance free type. It never needs servicing. When battery replacement is necessary (**Part #: MP120800**).

1. Push machine to level surface.
2. Turn off LP cylinder and remove it.

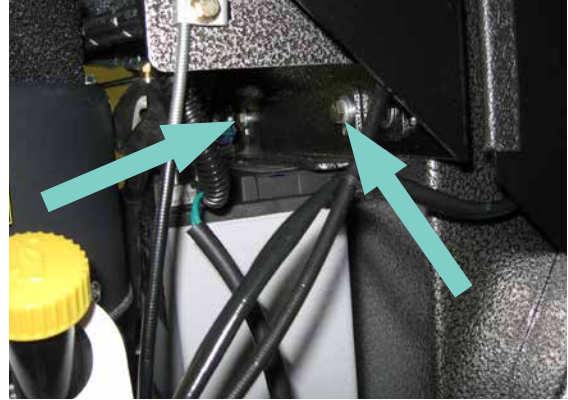

3. Disconnect the BLACK negative battery cable first. Disconnect the RED positive battery cable last.
4. Remove the two bolts shown and then remove the battery retaining bracket.
5. Lift out old battery and replace with new battery.
6. Secure battery with battery retaining bracket.
7. Connect the RED positive battery cable first. Connect the BLACK negative battery cable last.

NOTE: Dispose of old battery in the proper manner. Most auto parts stores accept used batteries for recycling.

PROPOSITION 65 WARNING

- Battery posts, terminals, and related accessories contain lead and lead compounds, chemicals known to the State of California to cause cancer and reproductive harm.
- Batteries also contain other chemicals known to the State of California to cause cancer.
- Wash hands after handling.

Gearbox Maintenance

Check Gearbox Oil Level:

1. Push machine to level surface.
2. Turn off LP cylinder and remove it.
3. Level the machine by raising or lowering the axle with the "T-Handle" adjustment over the axle.
4. Place a rag underneath the drain port of each gearbox to prevent oil from leaking onto the machine.
5. Loosen the oil drain plugs from front of the gearboxes. If oil starts to leak out, then the gearboxes do not need oil. If the oil does not start to leak out, add oil (AGMA 5EP Gear Oil or equivalent gear lubricant) until the oil level is just below the bottom of the oil drain hole.

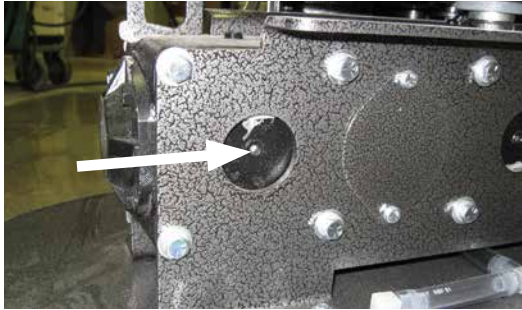

6. Add thread sealant to the oil drain plug, install in gearbox, and tighten.

Re-Lubrication: Service life and efficiency of gears and bearings will be affected by oxidation and contamination of the lubricating oil. Improved performance will be obtained by periodic re-lubrication in accordance with the following recommendations.

After an initial break-in period of approximately 500 hours, the gear oil in each gearbox should be completely drained and replaced. Under normal conditions, once the break-in oil has been changed at 500 hours, the drive should be re-lubricated at intervals of approximately 2500 hours of operation.

Changing Gearbox Oil / Changing Gearbox:

1. Push machine to a level surface.
2. Turn off LP cylinder and remove it.
3. Rock the machine back by pushing down on one of the foot pegs while pulling back on the handle.
4. Remove the Skirt from the machine (see *the Skirt* section).
5. Remove the pad holders, brushes, or head assemblies from the drivers by rotating the heads toward the center of the machine (see *Head Change* section).

CAUTION! ENGINE AND EXHAUST COMPONENTS MAY BE HOT. USE EXTREME CAUTION WHEN WORKING NEAR THESE COMPONENTS.

6. Remove the left side cover plate by removing the (2) 1/4" bolts.



7. Remove the pulley cover by removing the (6) 1/4" bolts

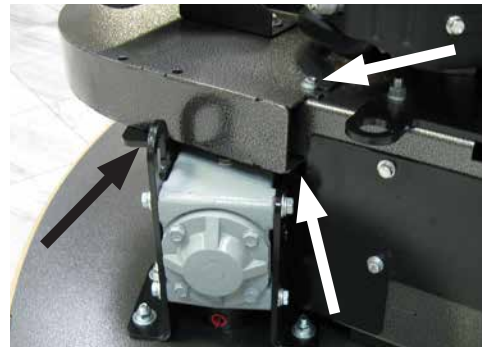
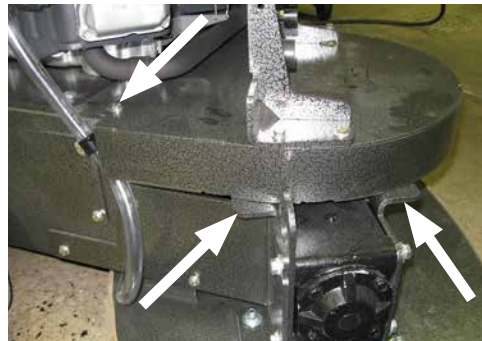

8. Remove the cap from the gearbox support spacer on each head. Turn each head until the set screws align with the access hole. Remove both of the two set screws in each driver hub.



- Remove the 1/4" bolt from the center of each driver assembly. Remove the driver assembly from the gearbox shaft. (Note: Slowly threading a 3/8"-16 X 4" Tap Bolt into the bottom of the driver assembly will push the driver assembly off of the gearbox shaft).

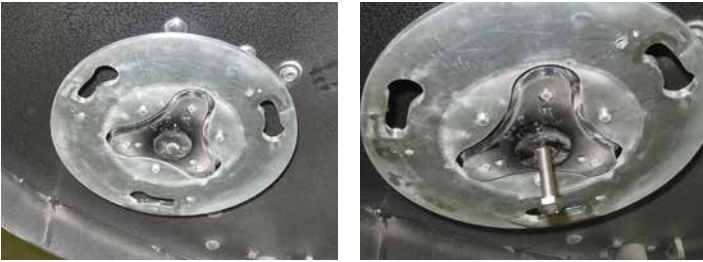

- Remove the drive belt from the gearbox pulley.

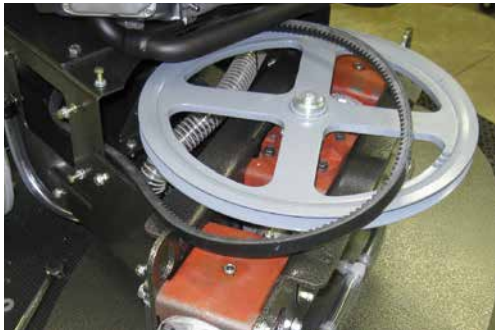

- Remove the two 3/8" bolts that attach the gearbox support brace to the gearbox assembly.

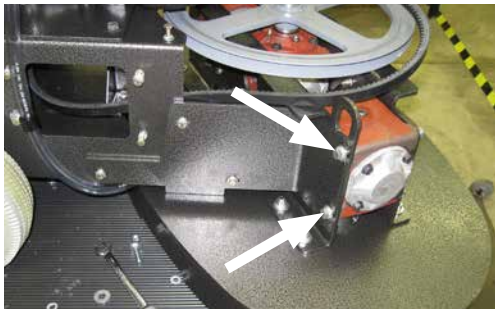

- Remove the (8) bolts that attach the gearbox assembly to the deck. (Note: Mark the gearbox assembly so that it cannot be installed on the machine backwards).



- (Note: This step requires a hoist or the assistance of another person.) Tilt the gearbox assembly toward the front of the machine and lift off the deck.

Changing Gearbox Oil

- Remove the oil plug from each gearbox (3).

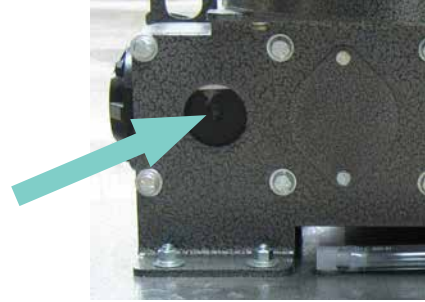

- Tilt the gearbox assembly over on its side so that the oil can drain. (Note: Place a catch pan under the assembly.)



- After the oil has drained, turn the gearbox assembly over on the other side so the fill ports are turned up.
- Add 16oz. (473 ml) AGMA 5EP Gear Lubricant or equivalent gear lubricant to each gearbox.
- The oil level in each gear box should be just below the bottom of the oil drain port when the gearbox assembly is setting upright on a level surface.

WARNING! ALL GEARBOXES MUST BE FILLED TO PROPER LEVEL WITH RECOMMENDED LUBRICANT BEFORE OPERATION.

- Install plug in each gearbox using a thread sealant and properly tighten.
- Dispose of used oil properly.
- Check gearbox oil level every 100 hours and add oil if needed.

Gearbox Replacement:

1. Remove the front gearbox mount plate from the gearbox assembly by removing the twelve (12) bolts from the front of the gearboxes.

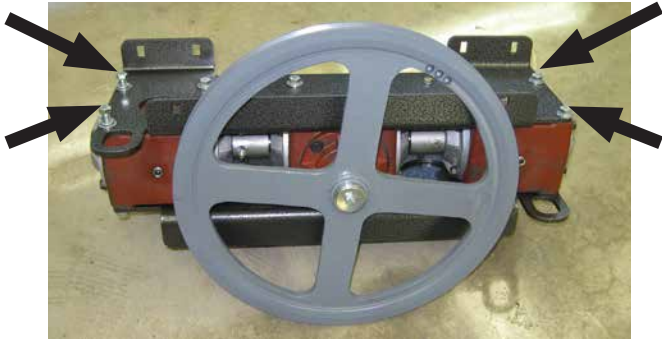

2. Remove the shear pin from the coupling of the gearbox being replaced.
3. Remove the remaining bolts that fasten the gearbox to the rear mounting plate.
4. Remove the gearbox from the gearbox assembly.
5. Prior to installing the new gearbox, verify the oil level by removing the oil drain plug. (Note: Refer to Changing Gearbox Oil section for the proper oil level and the recommended oil type.)
6. Attach the new gearbox to the gearbox assembly by first inserting the input shaft into the shear coupling and then align the mounting holes with the rear mounting plate. Start the bolts, but do not tighten.
7. Turn the gearbox pulley until the hole in the shear pin coupling aligns with the hole in the gearbox shaft. With the holes aligned insert the shear pin assembly, but do not tighten.
8. When the gearbox is aligned with the center gearbox, tighten the bolts retaining it to the rear mounting plate. Then tighten the shear pin assembly to the shear coupling.
9. Attach the front mounting plate to the gearbox assembly using the twelve (12) bolts and tighten.
10. Turn the gearbox pulley to check for proper alignment and verify the new gearbox is working properly.

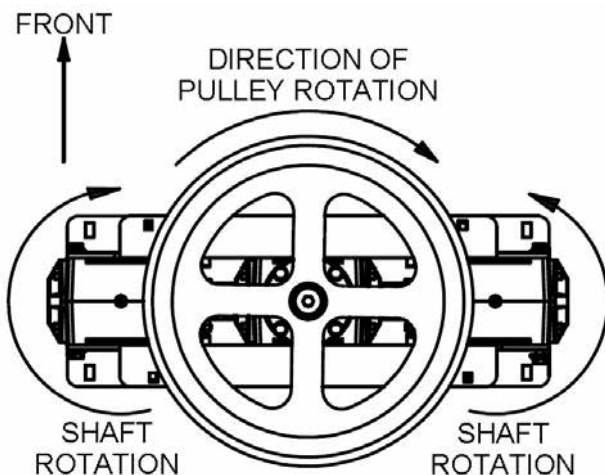

NOTE: Use diagram to verify proper orientation of gearbox asm.

11. Reverse steps 1-10 to reassemble the gearbox assembly to the machine.

NOTE: When attaching the gearbox assembly to the deck, make sure the gearboxes are seated properly and centered on the gearbox support spacers.

NOTE: Apply Anti-Seize to the gearbox shafts prior to installing the driver assemblies.

NOTE: Clean set screws and apply a medium strength threadlocker prior to assembly.

Maintenance: Lash and end play should be checked every time the drive is relubricated. If too much lash or end play is felt, the drive should be inspected. Contact a certified APEC technician.

Operating Temperature: During the initial break-in period, the operating temperature of the unit should not exceed 250°F (121°C). After break-in, the normal operating temperature should not exceed 220°F (104°C).

Machine Storage

Only authorized, trained personnel should have access to propane cylinders and machines.

1. Remove propane fuel cylinder when not in use and store it outside in a storage cage in accordance with NFPA Handbook 58 CAN/CGAB149.2. Do not release or bleed propane inside the building. Please consult your local Fire Marshal to ensure that you are in compliance with local fire codes.
2. Store machine away from objects that may fall and damage it.
3. Never store machine or fuel cylinders near an open flame or heat-producing device.
4. Make sure machine is cleaned properly before storing.
5. Never store machine with cylinders installed, or store spare cylinders in an enclosed van or trailer.
6. Store machine in a dry location, temperature not to exceed 120°F (50°C).

Repacking the Machine

Refer to *Unpacking* and repack the machine using original packing materials and container. Store machine in a dry location, temperature not to exceed 120°F (50°C).

Loading the Machine

1. Turn the machine OFF.
2. Remove Skirt. See Removing & Installing Skirt section.
3. Hook the Transport handle to the bracket under the deck.



4. With two people, one pushing the machine and one pulling the machine with the transport handle, load the machine onto the truck or trailer.



5. Secure the machine with ratchet straps.



Transporting the Machine

When transporting a propane powered floor machine with the fuel cylinder installed, the cylinder should be securely fastened with the service valve closed and the machine should be secured in the vehicle. Any propane fuel cylinders not installed should be securely fastened to avoid movement and damage. Never store machine with cylinder installed or store spare cylinders in an enclosed van or trailer. It is a good practice to check propane cylinders for overfilling before transporting them. If overfilled, correct before loading them in the vehicle by venting the excess propane outside in a safe area using the bleeder valve.

Machine Specifications

<u>Starting:</u>	12VDC, 275 CCA, AGM Starter Battery
Battery:	MP120800
<u>Deck:</u>	Fabricated Steel Sheet Metal Construction with a Powder Coat Finish
<u>Sound Level:</u>	< 89 dB(A)
<u>Vibration:</u>	Less than 2.5 m/s ²
<u>Engine:</u>	Kawasaki FS481V, 603cc Air Cooled
<u>Engine Speed:</u>	Idle - 1800-2000 rpm High Idle - 3600 rpm
<u>Engine Oil:</u>	SAE 30 w/ API Service SH or SJ
<u>Engine Oil Capacity:</u>	Filter not removed - 1.6qt (1.5L) Filter removed - 1.8qt (1.7L)
<u>Engine Oil Filter:</u>	KA490657007
<u>Engine Air Filter:</u>	KA110130752 (<i>Paper Element</i>)
<u>Engine Air Filter:</u>	KA110137046 (<i>Foam Element</i>)
<u>Spark Plug:</u>	KA920702112
<u>Spark Plug Gap:</u>	0.025 in. (0.635 mm)
<u>LP Cylinder Type:</u>	MP105900 - 20lb (9.1 kg) Vapor Withdraw
<u>Deck Drive:</u>	Electric Clutch with B-Section Belt
Clutch:	MP4787
Drive Belt:	MP273000
<u>Fuse:</u>	SS2570 (20A)
<u>Splash Skirt:</u>	MP495000

Machine Dimesions:

Pad Size:	(2) x 17" (43.2 cm)
Driver Speed:	255 - 410 RPM
Width:	36" (91.4 cm)
Length (Max):	60.0" (152.4 cm)
Height (Max):	46.3" (117.6 cm)
Weight:	538 lbs (<i>w/o cylinder</i>) (244 kg)
Head Width:	33.5" (85.1 cm) Effective

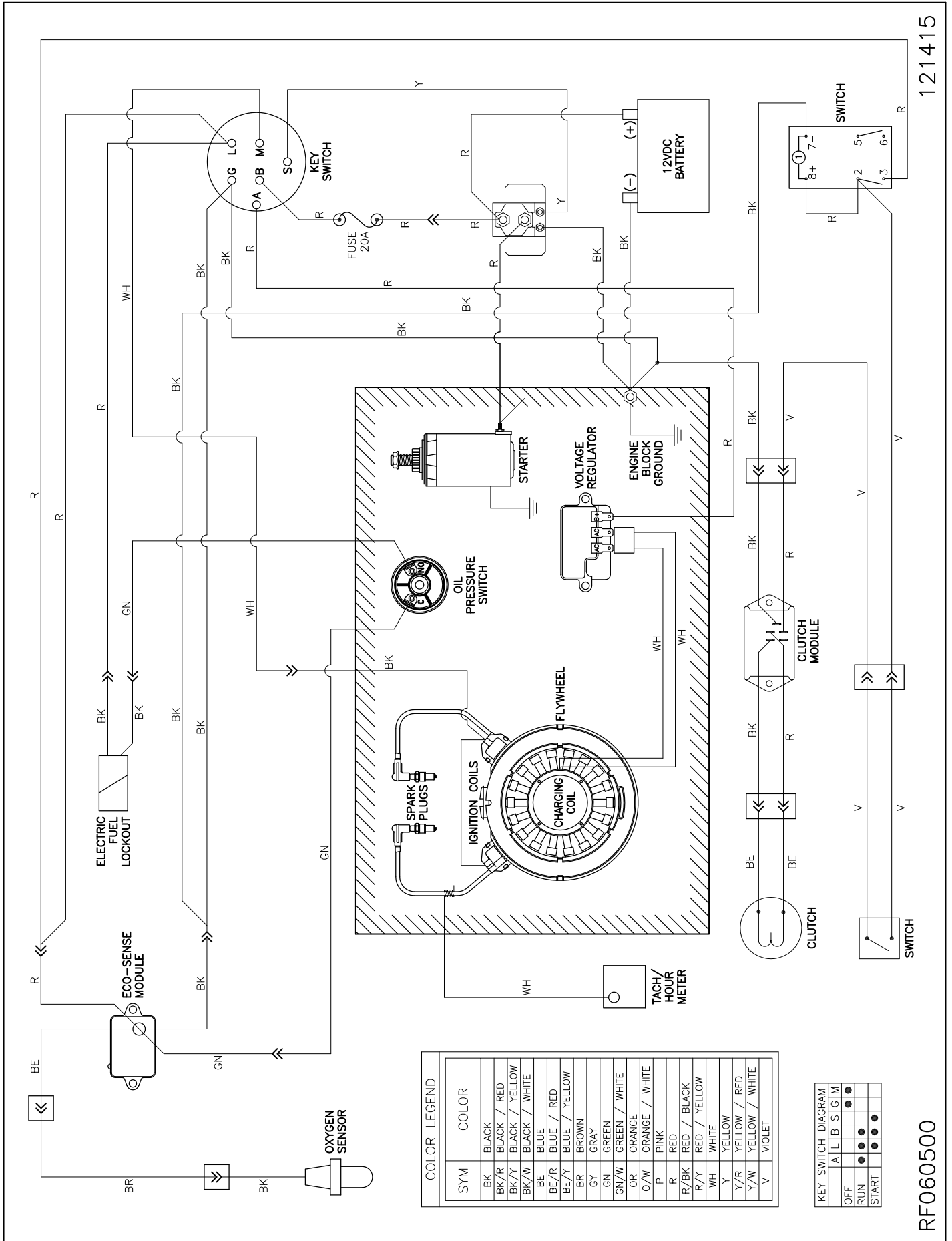

COLOR LEGEND

SYM	COLOR
BK	BLACK
BK/R	BLACK / RED
BK/Y	BLACK / YELLOW
BK/W	BLACK / WHITE
BE	BLUE
BE/R	BLUE / RED
BE/Y	BLUE / YELLOW
BR	BROWN
GY	GRAY
GN	GREEN
GN/W	GREEN / WHITE
OR	ORANGE
O/W	ORANGE / WHITE
P	PINK
R	RED
R/BK	RED / BLACK
R/Y	RED / YELLOW
WH	WHITE
Y	YELLOW
Y/R	YELLOW / RED
Y/W	YELLOW / WHITE
V	VIOLET

KEY SWITCH DIAGRAM

	A	L	B	S	G	M
OFF						●
RUN	●					●
START	●	●	●	●	●	●

121415

RF060500

Connections

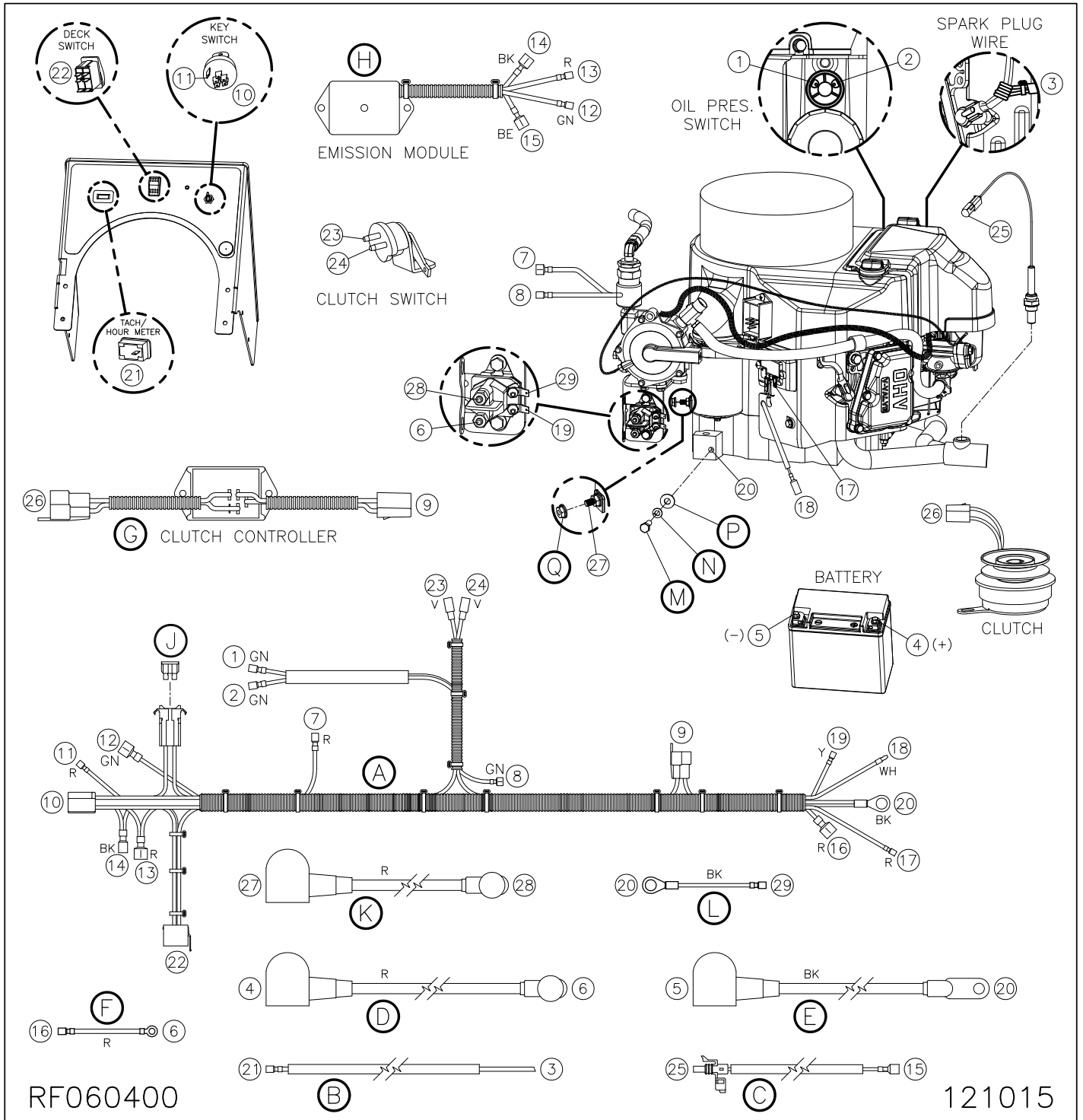

Item	Ref. No.	Description	Qty	Item	Ref. No.	Description	Qty
A	MP400900	HARNES, WIRING, MAIN	1	J	SS2570	FUSE, 20A	1
B	MP311500	WIRE, METER, HOUR	1	K	MP366700	CABLE, BATTERY, POSITIVE, 9"	1
C	MP373000	WIRE, SENSOR, OXYGEN	1	L	MP427700	WIRE, BLACK, 12"	1
D	MP2011	CABLE, BATTERY, POSITIVE	1	M	NB065100	BOLT, HEX, M8 X 25MM	1
E	MP2012	CABLE, BATTERY, NEGATIVE	1	N	NB6111	WASHER, LOCK, 5/16"	1
F	MP354900	WIRE, SOLENOID, BATTERY	1	P	NB9267	WASHER, FLAT, 5/16"	1
G	MP442500	CONTROLLER, CLUTCH, ASM.	1	Q	NB9545	NUT, FLANGE, 1/4"	1
H	MP402300	MODULE, EMISSION, ASM.	1				

Engine Assembly

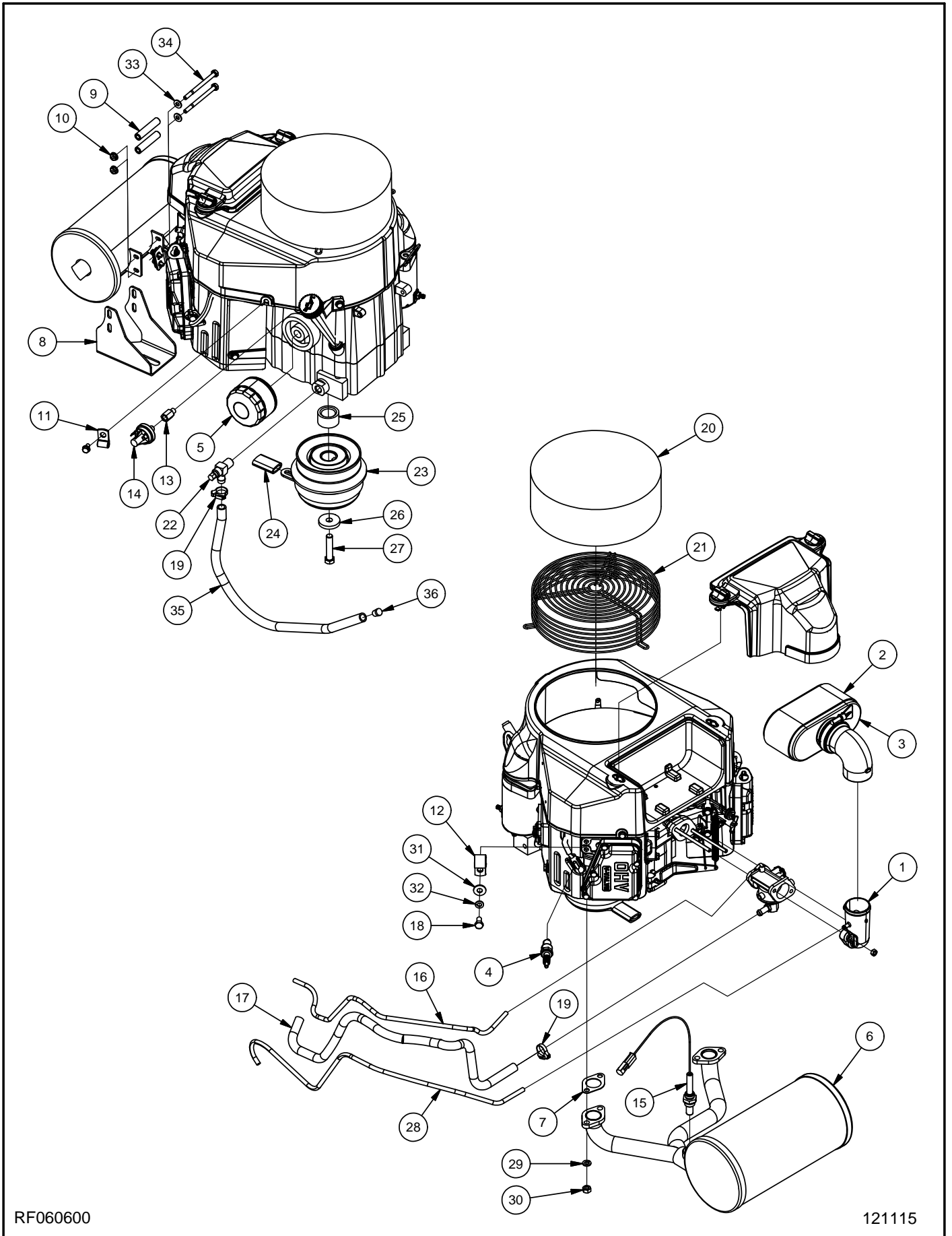

RF060600

121115

Engine Assembly (continued)

<u>Item</u>	<u>Ref. No.</u>	<u>Description</u>	<u>Qty</u>	<u>Item</u>	<u>Ref. No.</u>	<u>Description</u>	<u>Qty</u>
1	KA160600742	PIPE, INTAKE	1	19	NB7282	CLAMP, HOSE, 3/8"	2
2	KA110137046	FILTER, FOAM, AIR	1	20	MP371300	FILTER, INTAKE, ENGINE	1
3	KA110130752	ELEMENT, FILTER, AIR	1	21	MP371200	CAGE, INTAKE, ENGINE	1
4	KA920702112	PLUG, SPARK, NGK, BPR4ES	1	22	MP072300	DRAIN, OIL	1
5	KA490657007	FILTER, OIL	1	23	MP4787	CLUTCH, ASM	1
6	MP364900	MUFFLER, CATALYST	1	24	MP4790	TUBING, RUBBER	2"
7	KA110607016	GASKET, MUFFLER	2	25	MP298000	SPACER, CLUTCH (TOP)	1
8	MP455601	BRACKET, BRACE, MUFFLER	4	26	MP4805	SPACER, CLUTCH (BOTTOM)	1
9	MP455900	SPACER, 1/2" OD X 1/4" ID	2	27	NB032300	BOLT, HEX, 7/16" X 2"	1
10	NB9545	NUT, FLANGE, 1/4"	1	28	NB2460	HOSE, VACUUM, 5/32"	31"
11	NB8125	CLAMP, 1/4" ID	1	29	KA461DA0800	WASHER, LOCK, 8MM	4
12	NB8310	CLAMP, 3/4"	1	30	KA922107027	NUT, HEX, M8	4
13	MP044800	ADAPTER, CONVERSION	2"	31	NB9267	WASHER, FLAT, 5/16"	1
14	MP019200	SWITCH, PRESSURE, DP	1	32	NB6111	WASHER, LOCK, 5/16"	1
15	MP466500	SENSOR, OXYGEN	1	33	NB3350	WASHER, FLAT, 1/4"	2
16	NB2460	HOSE, VACUUM, 5/32"		34	NB068500	BOLT, HEX, 1/4" X 3-1/2"	2
17	NB2470	LINE, FUEL, 3/8"		35	MP4515	TUBING, DRAIN, OIL	18"
18	NB065000	BOLT, HEX, M8 X 16		36	NB1621	PLUG, RED	1

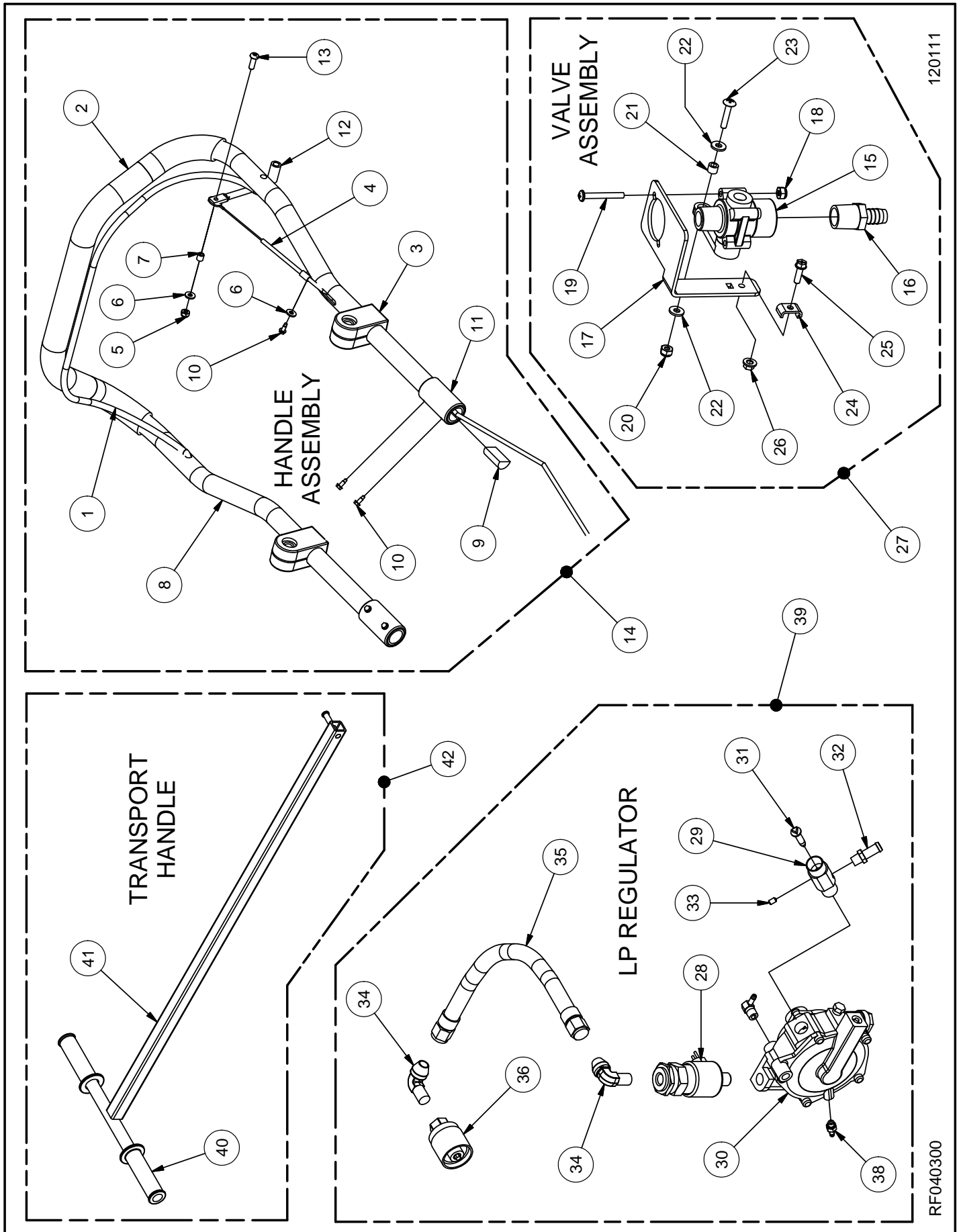

120111

RF040300

Regulator & Handle Assembly (continued)

<u>Item</u>	<u>Ref. No.</u>	<u>Description</u>	<u>Qty</u>	<u>Item</u>	<u>Ref. No.</u>	<u>Description</u>	<u>Qty</u>
1	MP042000	BAIL, BLACK	1	22	NB9645	WASHER, FLAT, #10	2
2	MP038600	GRIP, HANDLE	1	23	NB5350	SCREW, #10 X 1"	1
3	MP042100	BLOCK, SLIDE, HANDLE	2	24	KA921707001	CLAMP	1
4	MP106500	CABLE, THROTTLE	1	25	KA921502182	BOLT, M5	1
5	NB9735	NUT, LOCK, #10	1	26	NIG5055	NUT, FLANG, 5MM	1
6	NB9645	WASHER, FLAT, #10	2	27	MP300800	VALVE, ASM.	1
7	NB028300	BUSHING, CABLE	1	28	MP317500	FUELOCK, 12V, ASM.	1
8	MP389101	HANDLE, BULKHEAD	1	29	MP015100	FITTING, FUEL ADJUST	1
9	MP400400	BLOCK, GUIDE, CABLE	1	30	SA026300	REGULATOR, LP	1
10	NB4382	SCREW, #8 X 1/2"	5	31	MP017300	SCREW, ADJUST, FUEL	1
11	MP045600	SLEEVE, STOP, HANDLE	2	32	MP018900	FITTING, H.BARB, 1/8" NPT	1
12	MP049800	TUBE, VINYL, 1/4" ID	1"	33	NB005200	SCREW, SET, #10-24 X 5/16"	1
13	NB049000	SCREW, 1/4" X 3/4"	1	34	MP4330	FITTING, 49 X 6	2
14	MP400300	HANDLE, ASM.	1	35	MP4300	HOSE, LP FUEL, 18"	1
15	MP416900	VALVE, TWO-WAY	1	36	MP4500	COUPLER, REGO	1
16	MP164100	FITTING, 1/2" HB X 1/2" MNPT	1	37	MP372400	FITTING, ELBOW, 1/8" NPT	1
17	MP146100	BRACKET, VALVE	1	38	MP371100	FITTING, 1/4" X 3/16" HB	1
18	NB030700	NUT, LOCK, #10	2	39	MP416300	REGULATOR, LP, ASM.	1
19	NB027500	SCREW, #10 X 1-1/2"	2	40	MP237400	GRIP, HANDLE	2
20	NB9735	NUT, LOCK, #10	1	41	MG003500	HANDLE, TRANSPORT	1
21	NB039000	BUSHING, PIVOT	1	42	MG003400	HANDLE, TRANSPORT, ASM.	1

Bulkhead & Control Panel Assembly

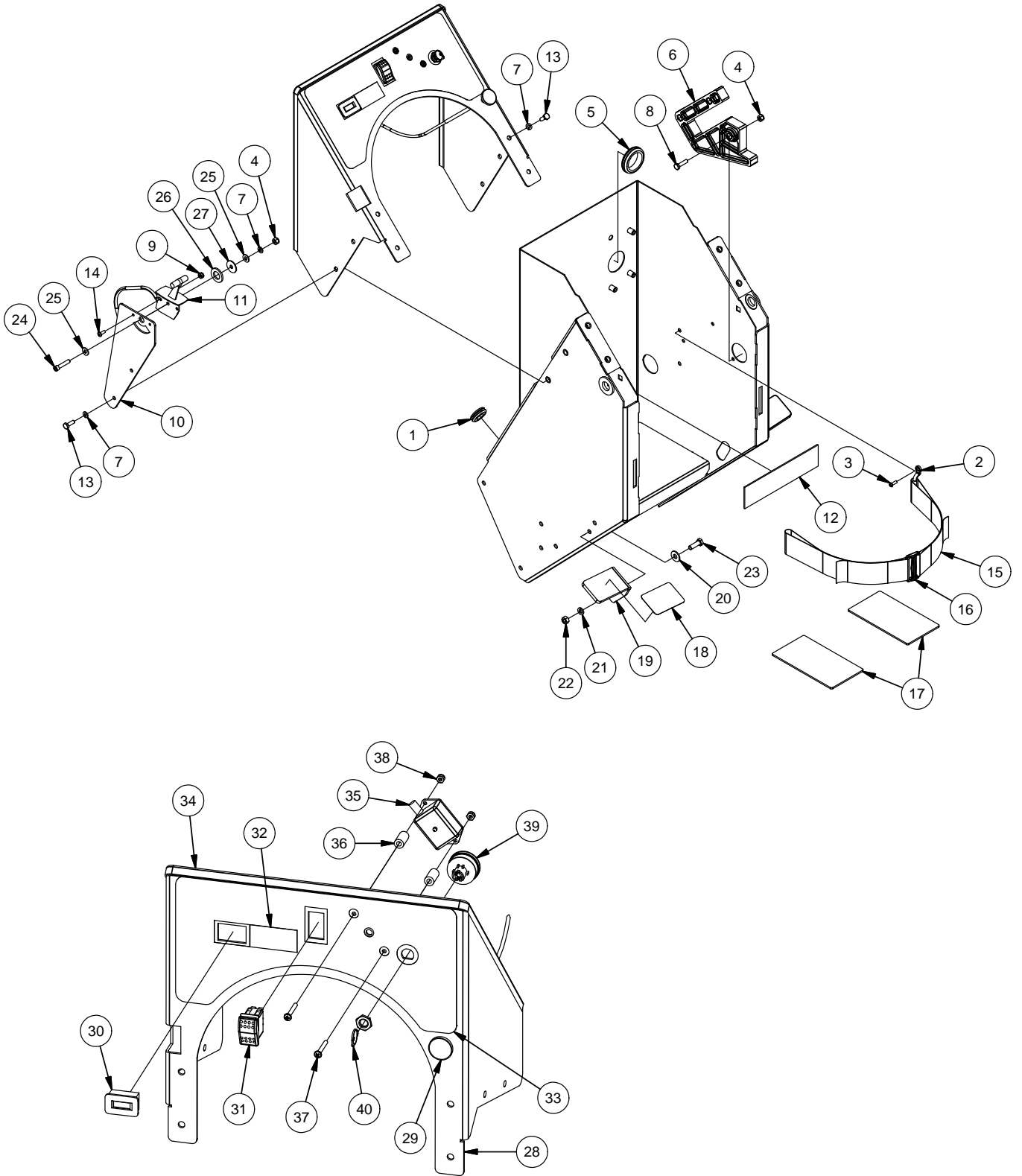

Bulkhead & Control Panel Assembly (continued)

<u>Item</u>	<u>Ref. No.</u>	<u>Description</u>	<u>Qty</u>	<u>Item</u>	<u>Ref. No.</u>	<u>Description</u>	<u>Qty</u>
1	NB009900	GROMMET, 11/16"	1	21	NB6111	WASHER, LOCK, 5/16"	4
2	RV009500	LOOP, FOOTMAN	2	22	NB3260	NUT, HEX, 5/16"	4
3	NB010400	SCREW, #10 X 5/8"	4	23	NB6545	BOLT, HEX, 5/16" X 1"	4
4	NB3275	NUT, LOCK, 1/4"	7	24	NB064100	BOLT, HEX, 1/4" X 1-1/4"	1
5	NB6514	GROMMET, 1-1/2" ID	2	25	NB3350	WASHER, FLAT, 1/4"	2
6	MP039300	PLATE, LOCK, HANDLE	2	26	NB060900	WASHER, FLAT, M16	1
7	NB6110	WASHER, LOCK, 1/4"	9	27	NB035000	WASHER, FENDER, 1/4" X 1"	1
8	NB6530	BOLT, HEX, 1/4" X 1"	6	28	MP408301	PANEL, CONTROL	1
9	NB9735	NUT, LOCK, #10	2	29	MP290400	CABLE, CONTROL	1
10	MP295301	BRACKET, THROTTLE	1	30	MP280400	METER, HOUR / TACH	1
11	MP402600	CABLE, THROTTLE	1	31	MP180000	SWITCH, ROCKER	1
12	MP6600	FELT, BLACK	(3) 8"	32	MP497100	DECAL, RPM	1
13	NB019100	BOLT, HEX, 1/4" X 3/4"	8	33	MP496400	DECAL, DASH	1
14	NB034100	SCREW, #10 X 1/2"	2	34	IN1015	TRIM	4 FT
15	MP368100	STRAP, 2" X 23"	2	35	MP402300	MODULE, EMISSION, ASM.	1
16	MP367600	SLIDE, STRAP, 2"	1	36	NB008600	SPACER, .50" OD X .25" ID	2
17	MP120700	PAD, BATTERY	2	37	NB027500	SCREW, #10 X 1-1/2"	2
18	MP210400	TREAD, PEDAL	2	38	NB9735	NUT, LOCK, #10	2
19	MP410701	PEDAL, FOOT	2	39	MP199000	SWITCH, IGNITION	1
20	NB9267	WASHER, FLAT, 5/16"	4	40	KC4834001	KEY, IGNITION (REPLACEMENT)	1

Frame Assembly

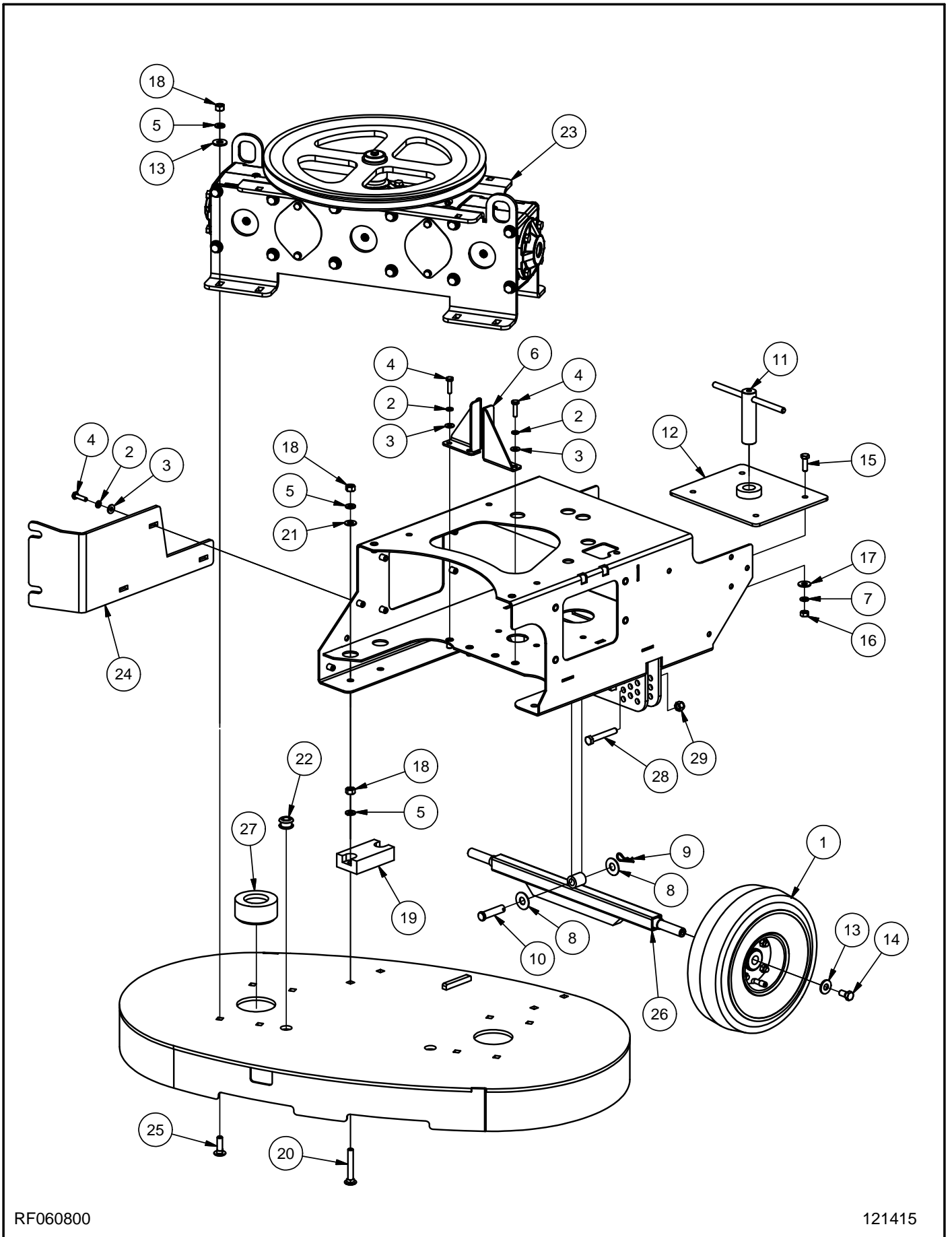

RF060800

121415

Frame Assembly (continued)

<u>Item</u>	<u>Ref. No.</u>	<u>Description</u>	<u>Qty</u>	<u>Item</u>	<u>Ref. No.</u>	<u>Description</u>	<u>Qty</u>
1	MP294300	WHEEL, 10"	2	16	NB3260	NUT, HEX, 5/16"	4
2	NB6110	WASHER, LOCK, 1/4"	7	17	NB9267	WASHER, FLAT, 5/16"	4
3	NB3350	WASHER, FLAT, 1/4"	7	18	NB046200	NUT, HEX, 3/8"	16
4	NB6530	BOLT, HEX, 1/4" X 1"	7	19	MP405401	BLOCK, SPACER, DECK	2
5	MX1075	WASHER, LOCK, 3/8"	16	20	NB053600	BOLT, CARRIAGE, 3/8" X 2-1/2"	4
6	MP295501	BRACKET, RETAINER	2	21	MX1080	WASHER, FLAT, 3/8"	4
7	NB6111	WASHER, LOCK, 5/16"	4	22	NB6525	GROMMET, 1/2" ID	2
8	NB034600	WASHER, FLAT, 1/2"	2	23	MP455400	GEARBOX, 34", ASM.	1
9	NB8175	PIN, 3/32"	1	24	MP401501	BRACKET, BRACE, DECK	1
10	NB033800	PIN, CLEVIS, 1/2" X 2"	1	25	NB5520	BOLT, CARRIAGE, 3/8" X 1-1/4"	8
11	MP297600	ADJUST, AXLE, ASM.	1	26	MP406400	AXLE	1
12	MP281100	PLATE, HUB	1	27	MP403601	SPACER, SUPPORT, G.BOX	2
13	NB3450	WASHER, FLAT, 3/8"	10	28	NB1588	BOLT, HEX, 3/8" X 2-1/2"	2
14	NB6851	BOLT, HEX, 3/8" X 3/4"	2	29	NB3267	NUT, LOCK, 3/8"	2
15	NB6545	BOLT, HEX, 5/16" X 1"	4				

Gearbox Assembly

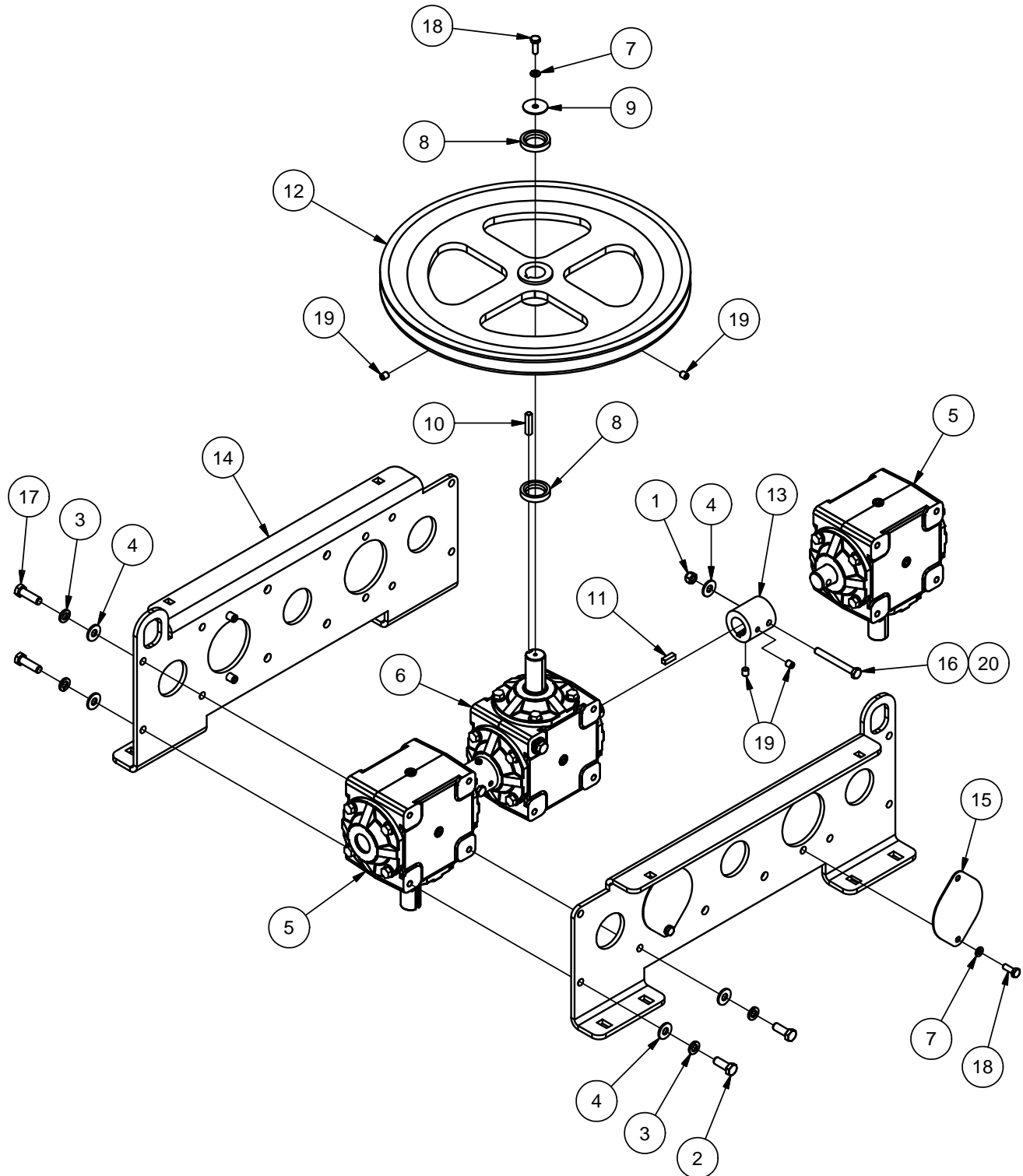

RF060900

121515

Gearbox Assembly (continued)

<u>Item</u>	<u>Ref. No.</u>	<u>Description</u>	<u>Qty</u>	<u>Item</u>	<u>Ref. No.</u>	<u>Description</u>	<u>Qty</u>
1	NB3265	NUT, LOCK, 5/16"	2	11	MP250500	KEY, 1/4" X 3/4"	2
2	NB6042	BOLT, HEX, 3/8" X 1"	22	12	MP400200	PULLEY, 1" X 15.75"	1
3	MX1075	WASHER, LOCK, 3/8"	24	13	MP455000	COUPLING, SHEAR, 5/16"	2
4	NB9267	WASHER, FLAT, 5/16"	26	14	MP416400	PLATE, MOUNTING, G.BOX	2
5	MP454600	GEARBOX, 1", R. ANGLE	2	15	MP405101	PLATE, COVER	2
6	MP454700	GEARBOX, 1", T-DRIVE	1	16	NB068400	BOLT, HEX, 5/16" X 2-3/4"	2
7	NB6110	WASHER, LOCK, 1/4"	5	17	NB6044	BOLT, HEX, 3/8" X 1-1/4"	2
8	MP371700	SPACER, 1.50" OD	2	18	NB6535	BOLT, HEX, 1/4" X 3/4"	5
9	NB006400	WASHER, FENDER, 1/4"	1	19	NB2463	SCREW, SET, 5/16"	6
10	MP326400	KEY, 1/4" X 1-1/4"	1	20	SA029400	BOLT, SHEAR, 5/16", KIT	1

Front Main Assembly

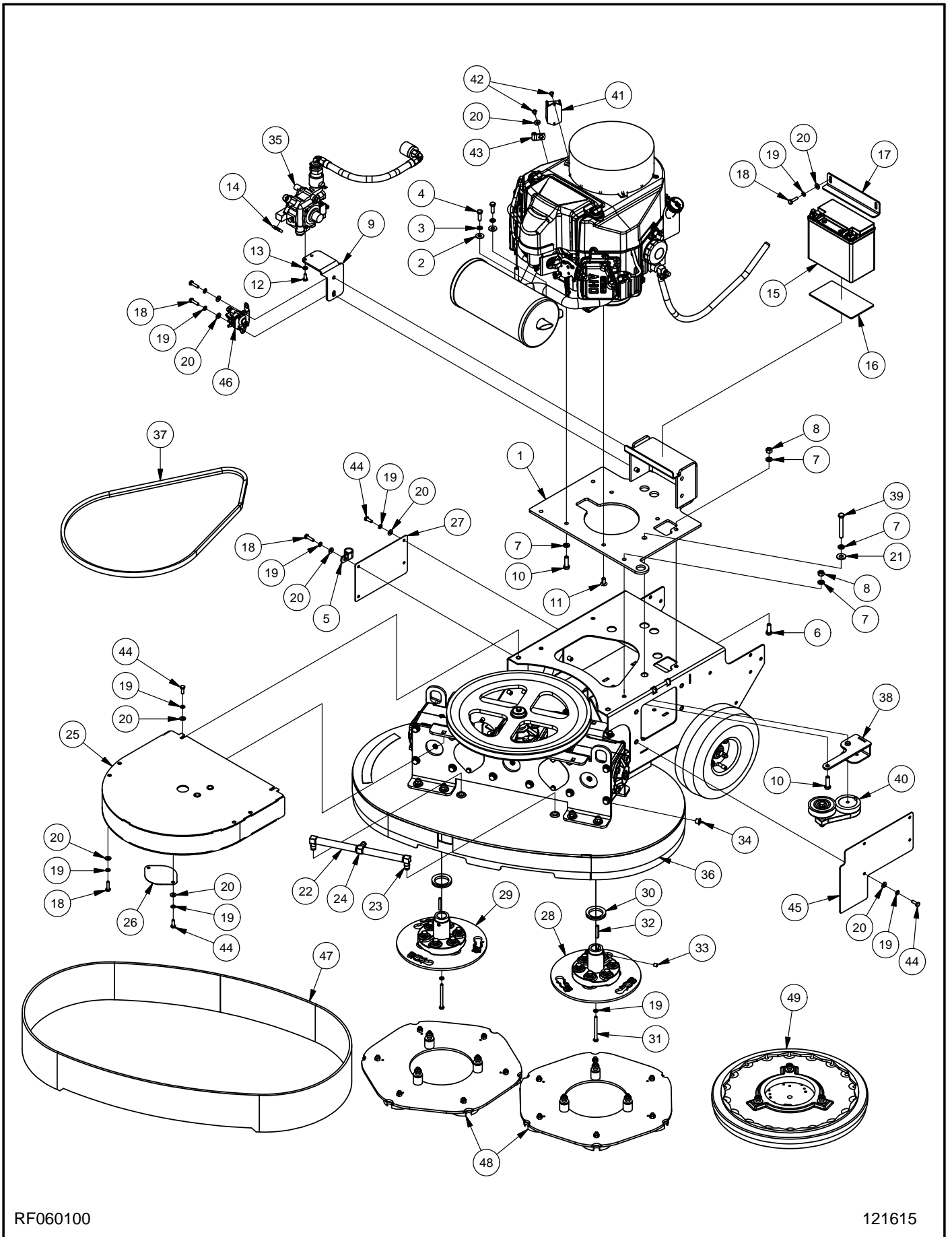

RF060100

121615

Front Main Assembly (continued)

<u>Item</u>	<u>Ref. No.</u>	<u>Description</u>	<u>Qty</u>	<u>Item</u>	<u>Ref. No.</u>	<u>Description</u>	<u>Qty</u>
1	MP416800	PLATE, ENGINE, ASM.	1	27	MP296401	PANEL, ACCESS	1
2	NB9267	WASHER, FLAT, 5/16"	2	28	MP408100	HUB, DRIVE, LEFT, ASM.	1
3	NB6111	WASHER, LOCK, 5/16"	2	29	MP408200	HUB, DRIVE, RIGHT, ASM.	1
4	NB6545	BOLT, HEX, 5/16" X 1"	2	30	NB055700	SEAL, V-RING, 1.5" ID	2
5	NB8130	CLAMP, 3/4"	1	31	NB056500	BOLT, HEX, 1/4" X 3"	2
6	NB6042	BOLT, HEX, 3/8" X 1"	3	32	MP7802	KEY, 1/4" X 1-1/2"	2
7	MX1075	WASHER, LOCK, 3/8"	8	33	NB2463	SCREW, SET, 5/16" X 3/8"	4
8	NB046200	NUT, HEX, 3/8"	4	34	NB066300	PLUG, PULL, 1/2"	2
9	MP404101	BRACKET, REGULATOR	1	35	MP416300	REGULATOR, ASM.	1
10	NB6044	BOLT, HEX, 3/8" X 1-1/4"	4	36	MP398400	TAPE, ANTI-SLIP	(2) 48"
11	NB065800	PLUG, HOLE, 5/16"	1	37	MP273000	BELT, BX-59	1
12	NB003200	BOLT, HEX, 1/4" X 5/8"	2	38	MP441500	BRACKET, TENSIONER	1
13	MX1115	WASHER, STAR, 1/4"	2	39	NB067800	BOLT, HEX, 3/8" X 2-3/4"	1
14	NB7282	CLAMP, HOSE	1	40	MP442200	TENSIONER, BELT, ASM.	1
15	MP120800	BATTERY, AGM, 12VDC	1	41	MP442500	CONTROLLER, CLUTCH, ASM.	1
16	MP120700	PAD, BATTERY	1	42	NB064900	SCREW, #10 X 1/2"	2
17	MP295601	BRACKET, BATTERY	1	43	NB8125	CLAMP, 1/4"	1
18	NB6530	BOLT, HEX, 1/4" X 1"	8	44	NB019100	BOLT, HEX, 1/4" X 3/4"	11
19	NB6110	WASHER, LOCK, 1/4"	21	45	MP495401	PANEL, ACCESS, FRAME	1
20	NB3350	WASHER, FLAT, 1/4"	20	46	MP367100	SOLENOID, STARTER, 12VDC	1
21	NB3450	WASHER, FLAT, 3/8"	1	47	MP495000	SKIRT, SPLASH	1
22	MP178000	TUBING, VINYL, 1/2"	(2) 5'	48	MP496100	PLATE, DRIVER, 17.5", ASM.	2
23	MP165300	FITTING, ELBOW, 1/2"	2	49	MP178800	PAD HOLDER, 17"	2
24	MP165200	FITTING, TEE, 1/2"	1	50	MP012700	RETAINER, PAD (NOT SHOWN)	2
25	MP495900	COVER, PULLEY, ASM.	1	51	MP178900	BRUSH, 17", GRIT (NOT SHOWN)	2
26	MP405101	PLATE, COVER, ACCESS	1	52	MP179100	BRUSH, 17", XTRA (NOT SHOWN)	2

Rear Main Assembly

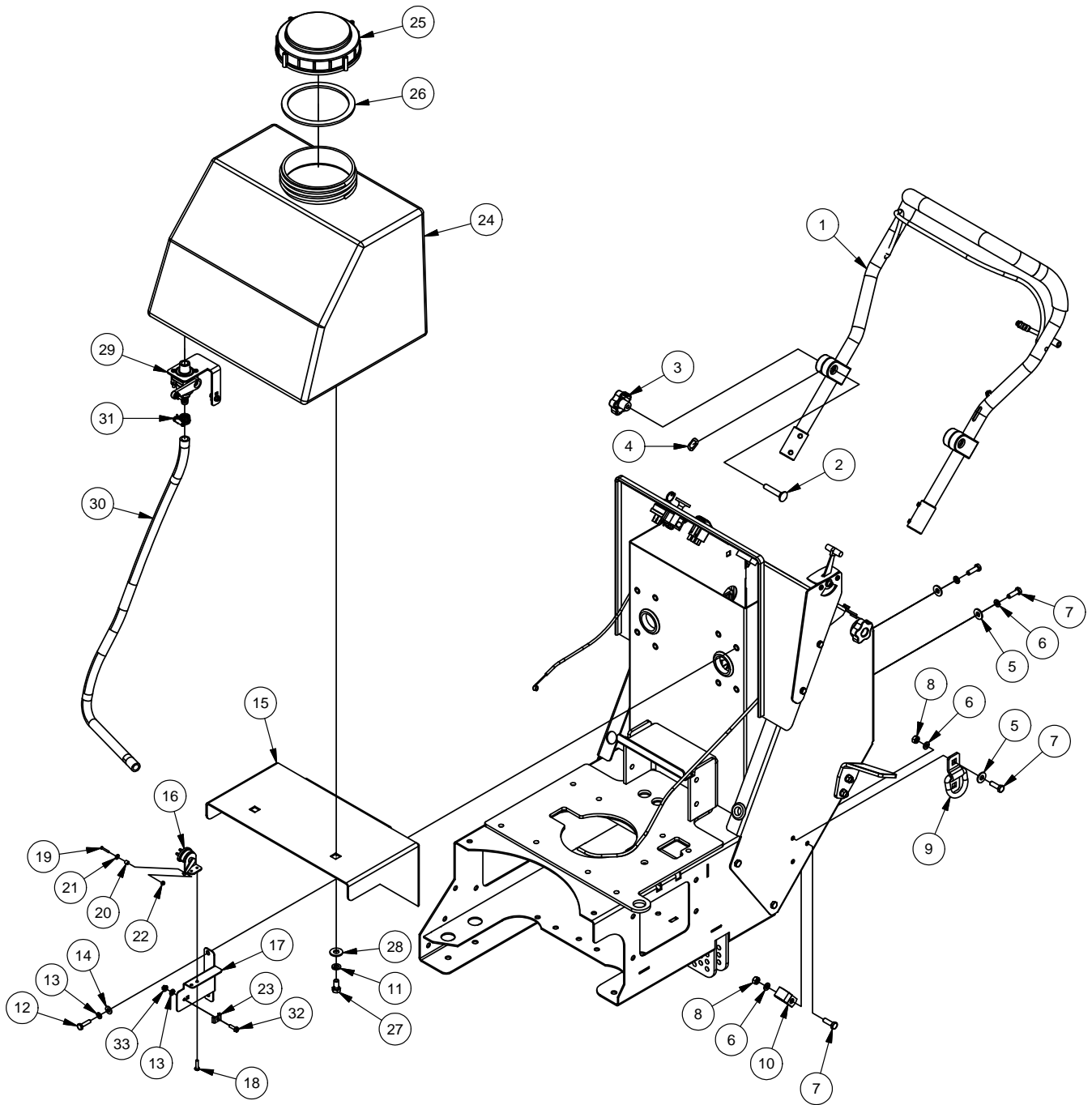

RF060200

121615

Rear Main Assembly (continued)

<u>Item</u>	<u>Ref. No.</u>	<u>Description</u>	<u>Qty</u>	<u>Item</u>	<u>Ref. No.</u>	<u>Description</u>	<u>Qty</u>
1	MP400300	HANDLE, ASM.	1	18	NB040400	SCREW, #10 X 3/4"	2
2	NB010100	BOLT, CARRIAGE, 3/8" X 2"	2	19	NB9625	SCREW, #4 X 3/4"	1
3	RV005100	KNOB, HANDLE	2	20	NB038900	SPACER, THREADED, #4 X 1/4"	1
4	NB011400	WASHER, WAVE, 1" OD	2	21	NB007100	WASHER, FLAT, #6	1
5	NB9267	WASHER, FLAT, 5/16"	6	22	NB007000	NUT, LOCK, #4	1
6	NB6111	WASHER, LOCK, 5/16"	12	23	MP098700	RETAINER, PIN, HITCH	1
7	NB6545	BOLT, HEX, 5/16" X 1"	12	24	MP281500	TANK, WATER	1
8	NB3260	NUT, HEX, 5/16"	10	25	MP152700	CAP, SCREW, #6	1
9	MP287900	RING, FLIP, 3/8"	2	26	MP152800	GASKET, CAP, 6"	1
10	NB8130	CLAMP, 3/4"	1	27	NB6851	BOLT, HEX, 3/8" X 3/4"	2
11	MX1075	WASHER, LOCK, 3/8"	2	28	NB3450	WASHER, FLAT, 3/8"	2
12	NB6530	BOLT, HEX, 1/4" X 1"	6	29	MP300800	VALVE, ASM.	1
13	NB6110	WASHER, LOCK, 1/4"	7	30	MP178000	TUBING, VINYL, 1/2"	40"
14	NB3350	WASHER, FLAT, 1/4"	6	31	NB043300	CLAMP, HOSE, 1/2"	1
15	MP296501	BRACKET, TANK	1	32	KA921502182	BOLT	1
16	MG002100	SWITCH, CLUTCH	1	33	NIG5055	NUT, FLANGE, 5MM	1
17	MP296601	BRACKET, SWITCH	1				

Head / Driver Assembly

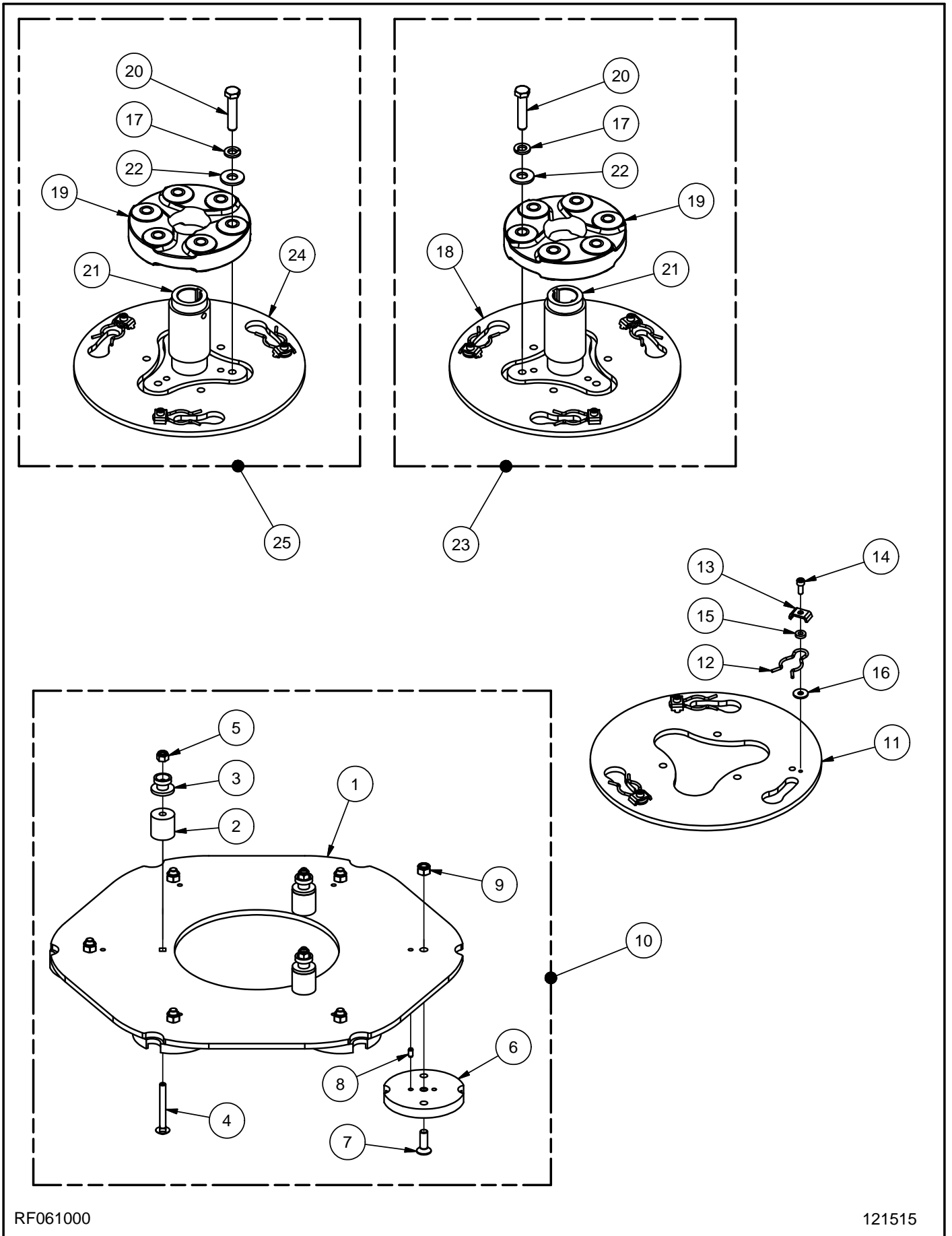

RF061000

121515

Head / Driver Assembly (continued)

Item	Ref. No.	Description	Qty	Item	Ref. No.	Description	Qty
1	MP496001	PLATE, DRIVER, 17.5"	1	14	NB060500	SCREW, SH, #10 X 1/2"	3
2	MP496600	SPACER, NYLON, 1" OD X 1"L	3	15	NB060600	WASHER, NYLON, .44" ID	3
3	MP197400	LUG, P74	3	16	NB060700	WASHER, NYLON, .63" OD	3
4	NB072000	BOLT, CARRIAGE, 1/4" X 2-1/4"	3	17	MX1075	WASHER, LOCK, 3/8"	6
5	NB3275	NUT, LOCK, 1/4"	3	18	MP312100	PLATE, CLUTCH, LEFT, ASM.	1
6	MP309200	HOLDER, LIPPAGE	6	19	MP317700	COUPLING, FLEXI	1
7	NB071800	SCREW, CS, M8 X 25MM	6	20	NB024500	BOLT, HEX, 3/8" X 1-3/4"	6
8	NB047800	PIN, ROLL, 3/16" X 3/8"	6	21	MP407200	HUB, DRIVE	1
9	NB071900	NUT, LOCK, M8	6	22	NB3450	WASHER, FLAT, 3/8"	6
10	MP496100	PLATE, DRIVER, 17.5", ASM.	1	23	MP408100	HUB, LEFT, ASM.	1
11	MP331100	PLATE, CLUTCH	1	24	MP312000	PLATE, CLUTCH, RIGHT, ASM.	1
12	NB024100	PIN, HITCH	3	25	MP408200	HUB, RIGHT, ASM.	1
13	MP098700	RETAINER, PIN, HITCH	3				

Diamonds



DP310RE - DISC, 3", REPAIR
DP310REK - DISC, 3", REPAIR, KIT (6 DISCS)



DP310PR - DISC, 3", PREP
DP310PRK - DISC, 3", PREP, KIT (6 DISCS)



DP310P1 - DISC, 3", POLISH 1
DP310P1K - DISC, 3", POLISH 1, KIT (6 DISCS)



DP310P2 - DISC, 3", POLISH 2
DP310P2K - DISC, 3", POLISH 2, KIT (6 DISCS)



DP310RE - DISC, 3", POLISH 3
DP310REK - DISC, 3", POLISH 3, KIT (6 DISCS)



DP310RE - DISC, 3", POLISH 4
DP310REK - DISC, 3", POLISH 4, KIT (6 DISCS)

Small Off-Road Engine Certification Warranty Form

Emission Control Warranty Statement

Your Warranty Rights and Obligations

The California Air Resources Board and Amano Pioneer Eclipse Corporation is pleased to explain the emissions control system's warranty on your 2016 small off-road engine. In California, new equipment that use small off-road engines must be designed, built, and equipped to meet the State's stringent anti-smog standards. Amano Pioneer Eclipse Corporation must warrant the emissions control system on your small off-road engine for the period listed below provided there has been no abuse, neglect or improper maintenance of your equipment. Your emissions control system may include parts such as: carburetor's or fuel injection system, ignition system, catalytic converters, fuel tanks, valves, filters, clamps, connectors, and other associated components. Also, included may be hoses, belts, connectors, sensors, and other emission-related assemblies. Where a warrantable condition exists, Amano Pioneer Eclipse Corporation will repair your small off-road engine at no cost to you including diagnosis, parts and labor.

Manufacturer's Warranty Coverage

This emissions control system is warranted for two years. If any emissions-related part on your equipment is defective, the part will be repaired or replaced by Amano Pioneer Eclipse Corporation.

Owner's Warranty Responsibilities

- (a) As the small off-road engine owner, you are responsible for performance of the required maintenance listed in your owner's manual. Amano Pioneer Eclipse Corporation recommends that you retain all receipts covering maintenance on your small off-road engine, but Amano Pioneer Eclipse Corporation cannot deny warranty solely for the lack of receipts or your failure to ensure the performance of all scheduled maintenance.
- (b) As the small off-road engine owner, you should however be aware that Amano Pioneer Eclipse Corporation may deny you warranty coverage if your small off-road engine or a part has failed due to abuse, neglect, or improper maintenance or unapproved modifications.
- (c) You are responsible for presenting your small off-road engine to an Amano Pioneer Eclipse Corporation distribution center or service center as soon as the problem exists. The warranty repairs should be completed in a reasonable amount of time, not to exceed 30 days. If you have a question regarding your warranty coverage, you should contact Amano Pioneer Eclipse Corporation at 1-800-367-3550.

Defects Warranty Requirements

- (A) The warranty period begins on the date the engine or equipment is delivered to an ultimate purchaser.
- (B) **General Emissions Warranty Coverage.** Amano Pioneer Eclipse Corporation as the manufacturer of each small off-road engine or equipment must warrant to the ultimate purchaser and each subsequent owner that the engine or equipment is:
 - (1) Designed, built, and equipped so as to conform with all applicable regulations adopted by the Air Resources Board; and
 - (2) Free from defects in materials and workmanship that causes the failure of a warranted part for a period of two years.
- (C) The warranty on emissions-related parts will be interpreted as follows:
 - (1) Any warranted part that is not scheduled for replacement as required maintenance in the written instructions required by subsection (D) must be warranted for the warranty period defined in Subsection (B2). If any such part fails during the period of warranty coverage, it must be repaired or replaced by the manufacturer according to Subsection (C4) below. Any such part repaired or replaced under the warranty must be warranted for the remaining warranty period.
 - (2) Any warranted part that is scheduled only for regular inspection in the written instructions required by subsection (D) must be warranted for the warranty period defined in Subsection (B2). A statement in such written instructions to the effect of "repair or replace as necessary" will not reduce the period of warranty coverage. Any such part repaired or replaced under warranty must be warranted for the remaining warranty period.

- (3) Any warranted part that is scheduled for replacement as replacement as required maintenance in the written instructions required by subsection (D) must be warranted for the period of time prior to the first scheduled replacement point for that part. If the part fails prior to the first scheduled replacement, the part must be repaired or replaced by the engine manufacturer according to Subsection (C4) below. Any such part repaired or replaced under warranty must be warranted for the remainder of the period prior to the first scheduled replacement point for the part.
- (4) Repair or replacement of any warranted part under the warranty must be performed at no charge to the owner at a warranty station.
- (5) Notwithstanding the provisions of Subsection (C4) above, warranty services or Repairs must be provided at all manufacturer distribution centers that are franchised to service the subject engines.
- (6) The owner must not be charged for diagnostic labor that leads to the Determination that a warranted part is in fact defective, provided that such diagnostic work is performed at a warranty station.
- (7) The manufacturer is liable for damages to other engine components Proximately caused by a failure under warranty of any warranted part.
- (8) Throughout the emissions warranty period defined in Subsection (B2), the manufacturer must maintain a supply of warranted parts sufficient to meet the expected demand for such parts.
- (9) Any replacement part may be used in the performance of any warranty Maintenance or repairs and must be provided without charge to the owner. Such use will not reduce the warranty obligations of the manufacturer.
- (10) Add-on or modified parts that are not exempted by the Air Resources Board may not be used. The use of any non-exempted add-on or modified parts will be grounds for disallowing a warranty claim. The manufacturer will not be liable to warrant failures of warranted parts caused by the use of a non-exempted add-on or modified part.
- (11) The manufacturer issuing the warranty shall provide any documents that describe that manufacturer's warrant procedures or policies within five working days of request by the Air Resources Board.

(D) Emission Warranty Parts List

- (1) Fuel Metering System
 - (a) Carburetor, internal parts, and pressure regulator.
 - (b) Cold start enrichment system.
- (2) Air Induction System
 - (a) Intake manifold.
 - (b) Air filter.
- (3) Ignition System
 - (a) Spark Plugs.
 - (b) Magneto or electronic ignition system.
 - (c) Spark advance/retard system.
- (4) Exhaust System
 - (a) Exhaust manifold.
- (5) Miscellaneous Items Used in Above Systems
 - (a) Electronic Fuel Cut-off control.
 - (b) Vacuum, temperature, time sensitive valves, and switches.
 - (c) Hoses, belts, connectors, and assemblies.

Amano Pioneer Eclipse Corporation will furnish with each new engine written instructions for the maintenance and use of the engine by the owner.

Exception: This warranty does not apply to any machine models that do not have a catalyst muffler.



SAFETY AWARENESS FORM FOR PROPANE MACHINES

The following must be completed before an employee may use a propane machine!

I have read the "Operators Manual" and understand it.

Name: _____ Date: _____
(Print or Type)

Demonstrate to your instructor that you can do the following properly and safely:

How to prepare the propane machine for operation:

- A. Install pads.....
- B. Check oil.....
- C. Adjust handle.....
- D. Check fuel cylinder for overfilling.....
- E. Install fuel cylinder.....
- F. Do you have a MSDS for propane?.....

How to operate a propane machine:

- A. Start and stop the engine.....
- B. Emergency stop.....
- C. Clean air filter.....

Cautions:

- A. Allow only qualified, trained personnel to operate the machine.
- B. Use only D.O.T. approved fuel cylinders supplied by Amano Pioneer Eclipse.
- C. Always store fuel cylinders outside in a proper enclosure.
- D. Never vent a fuel cylinder inside.
- E. Always wear a CO detector badge.
- F. Never leave the machine running unattended.
- G. Know what to do and whom to call in case of emergency.

When all items are checked off and this form is signed by an instructor or supervisor, you may operate a propane machine.

Employee Signature: _____ Date: _____

Instructor/Supervisor Signature: _____ Date: _____

Limited Warranty

PE430GP

TO QUALIFY FOR THIS WARRANTY

- (1) Machine must be registered at the time of purchase on a form provided by Amano Pioneer Eclipse Corporation. Your Amano Pioneer Eclipse Distributor is responsible for the registration of your machine. Please cooperate with your Distributor in supplying necessary information on the card.
- (2) The machine must have been purchased from Amano Pioneer Eclipse Corporation or an authorized Amano Pioneer Eclipse Distributor.
- (3) This warranty extends to the original purchaser only and is not transferable to subsequent owners.

TIME PERIODS

- (1) Propane engine warranted by engine manufacturer for (2) years.
- (2) Battery warranted by battery manufacturer for (1) year.
- (3) Valve train warranted by Amano Pioneer Eclipse for (1) year.
- (4) ONE (1) YEAR WARRANTY - For the PE430GP.
Warranted to be free from defects in material and workmanship for a period of one (1) year from the date of purchase by the original owners. (See Exclusions)

EXCLUSIONS (Not Covered by Warranty)

- (1) Parts that fail through normal wear by reason of their characteristics (cords, pads, belts, wheels, pad holder, or other consumable parts).
- (2) This warranty does not extend to parts affected by misuse, neglect, abuse or improper maintenance. All defective parts must be returned to the distributor for credit.

THE OBLIGATION OF AMANO PIONEER ECLIPSE CORPORATION

- (1) The obligation of Amano Pioneer Eclipse under this warranty is limited to repairing or replacing, at its option, any part which is proven to be defective in material or workmanship under normal use for the applicable period stated above.
- (2) Warranty repairs will be made by your Amano Pioneer Eclipse Distributor without charge for parts and labor. They will be compensated with a warranty labor rate of \$45.00 per hour, for the first year of ownership.
- (3) Parts repaired or replaced under this warranty are warranted only during the balance of the original warranty period. All defective parts replaced under these warranties become the property of Amano Pioneer Eclipse.

WARRANTY SERVICE

To obtain warranty service, take your machine and proof of purchase to any authorized Amano Pioneer Eclipse Distributor. Amano Pioneer Eclipse will not reimburse expenses for service calls or travel. For the Distributor in your area, call Amano Pioneer Eclipse Customer Service Department at 800-367-3550 or 336-372-8080. If you are dissatisfied with the service that you receive, call or write Amano Pioneer Eclipse Customer Service Department for further assistance.

INSTRUCTIONS AND CONDITIONS FOR WARRANTY REIMBURSEMENT

- Order replacement part: Orders will be processed and charged, as normal procedure.
- Call Amano Pioneer Eclipse for R/A number.
- You will need the Engine Serial Number, Machine Serial Number, and the Machine Model Number.
- Parts must be returned, accompanied with the R/A number to be eligible for warranty credit.
- All Warranty Parts will be shipped prepaid UPS Ground, any other method will be at the recipients expense.
- Freight on any Warranty Part after 30 days must be paid for by the Purchaser.
- Warranty labor rate is \$45.00 per hour.
- Credit will be issued upon completion of the above steps, at the above rates.

DISCLAIMER OF CONSEQUENTIAL

AMANO PIONEER ECLIPSE DISCLAIMS ANY RESPONSIBILITY FOR LOSS OF USER TIME OF THE AMANO PIONEER ECLIPSE MACHINE OR ANY OTHER INCIDENTAL OR CONSEQUENTIAL DAMAGE EXCEPT AS STATED IN THE WARRANTY APPLICABLE TO EACH MACHINE. EXCEPT AS STATED IN SUCH WARRANTIES, THE COMPANY DOES NOT OTHERWISE WARRANT ANY MACHINE AND NO WARRANTY, EXPRESS, IMPLIED OR STATUTORY IS MADE BY THE COMPANY.

Copyright 2016 Amano Pioneer Eclipse Corporation



Amano Pioneer Eclipse Corporation

1 Eclipse Rd ● PO Box 909
Sparta, North Carolina 28675 ● USA
www.pioneereclipse.com

+1-336-372-8080
1-800-367-3550
Fax 1-336-372-2913

EC Machinery Directive 2006/42/EC,
EC Restriction of Hazardous Substances Directive (2011/65/EU)
Harmonized Standards Applied: EN 12100-1, EN12100-2