

SABER™

GLIDE

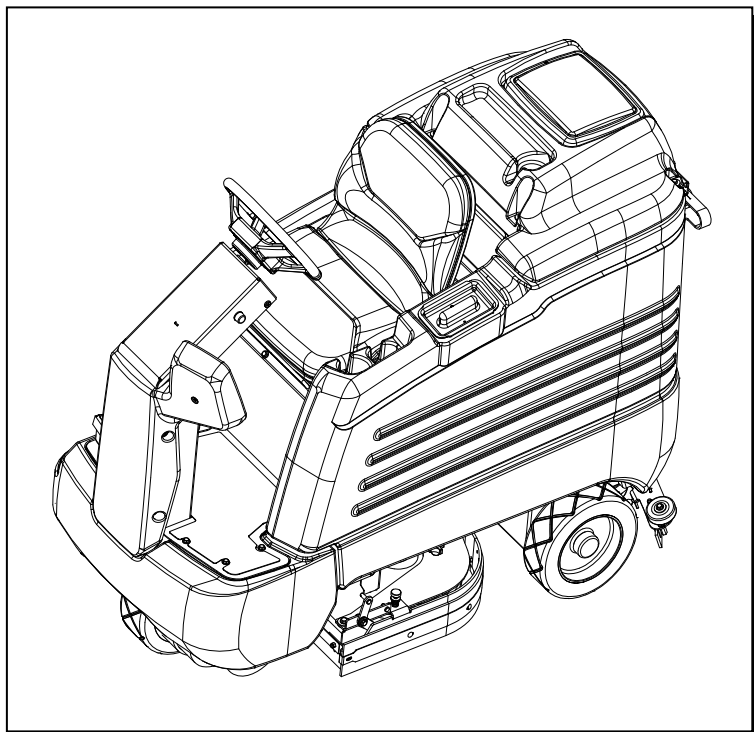

SCRUBBER



Operating Instructions (ENG)
Bedienungsanleitung (GER)
Istruzioni operative (ITA)
Manuel d'utilisation (FRE)

MODELS: SGE28
10052480

SGE36
10052500

SGE32
10052490

SGEO32
10052520

AFTER SN: 1000136404

QUEST® ... for Continuous Improvement.
Windsor's Quality Management System is Certified ISO 9001.

CE
IPX4

Read these instructions before using the machine
Bitte lesen Sie diese Anleitungen, bevor Sie die Maschine in Gebrauch nehmen
Leggere attentamente le presenti istruzioni prima di azionare la macchina
Lire ce manuel avant d'utiliser la machine



MACHINE DATA LOG/OVERVIEW

MODEL	_____
DATE OF PURCHASE	_____
SERIAL NUMBER	_____
SALES REPRESENTATIVE #	_____
DEALER NAME	_____
OPERATIONS GUIDE NUMBER	_____
PUBLISHED	_____

YOUR DEALER

Name: _____

Address: _____

Phone Number: _____

OVERVIEW

The Saber Glide is a battery powered, ride-on, hard floor scrubber intended for commercial use. The appliance applies a cleaning solution onto a hard floor, scrubs the floor with brushes or pads, and then vacuums the soiled water back into the recovery tank.

Warranty Registration

Thank you for purchasing a Windsor product. Warranty registration is quick and easy. Your registration will allow us to serve you better over the lifetime of the product.

To register your product go to:

www.windsorind.com/WarrantyRegistration.aspx

For customer assistance:

1-800-444-7654



TABLE OF CONTENTS

Machine Data Log/Overview	2
Table of Contents	3

HOW TO USE THIS MANUAL

How to use this Manual	1-1
------------------------------	-----

SAFETY

Important Safety Instructions	2-1
Hazard Intensity Level	2-2
Safety Label Location	2-3

OPERATIONS

Technical Specifications	3-1
How the Machine Works	3-3
Components	3-4
Controls	3-5
Machine Operation	3-14
Pre-Run Machine Inspection	3-14
Starting Machine	3-14
Filling the Solution Tank	3-14
Scrubbing	3-14
Emergency Stop Procedures	3-15
Emptying & Cleaning Tanks	3-16

MAINTENANCE

Maintenance	4-1
Batteries	4-2
Battery Maintenance	4-2
Checking Battery Specific Gravity	4-2
Charging the Batteries	4-3
Changing Batteries	4-4
Battery Connections	4-4
Battery Tray Drain Hose	4-4
Squeegee	4-5
Adjusting Pitch	4-5
Replace/Rotate Rear Squeegee Blade	4-6
Removing Squeegee Assembly	4-6
Replace/Rotate Front Squeegee Blade	4-6
Side Squeegee	4-7
Replace/Rotate Side Squeegee Blades	4-7
Adjusting the Side Squeegee Deflection	4-7
Scrub Brush Replacement	4-8
Brake	4-9
Steering Chain Tensioner	4-9
Vacuum Motor	4-10
Brush Motor	4-11
Traction Motor	4-12
Fuse	4-12
Circuit Breakers	4-12
Squeegee Actuator	4-13
Scrub Deck Actuator	4-14
Transporting Machine	4-15
Jacking Machine	4-16

Service Schedule	4-17
Machine Troubleshooting	4-18

GROUP PARTS LIST

Brake- From SN.	5-1
Brake- To SN.	5-3
Circuit Breaker	5-5
Control Panel	5-7
Decal	5-9
Front Bumper & Floor	5-11
Fwd/Rev Pedal	5-13
Scrub Brush/Driver	5-15
Scrub Deck-28 in Disk	5-17
Scrub Deck Side Squeegee-28 in Disk	5-19
Scrub Deck Lift-28 & 32 in	5-21
Scrub Deck-32 in	5-23
Scrub Deck Side Squeegee-32 in	5-25
Scrub Deck-36 in Main	5-27
Scrub Deck-36 in Retractable	5-29
Scrub Deck Side Squeegee-36 in	5-31
Scrub Deck Lift-36 in	5-33
Seat & Side Cover	5-35
Solution Delivery	5-37
Squeegee-28 in & 36 in	5-39
Squeegee -32 in	5-41
Squeegee Lift	5-43
Steering-Upper	5-45
Steering-Lower	5-47
Tank	5-49
Tank Cover	5-51
Vacuum	5-53
Wheel & Frame	5-55
Wheel Motor	5-57
Wiring-Battery	5-59
Wiring-Main Harness	5-61
Wiring-Main Harness Connection	5-63
Wiring-Control Panel Group	5-65
Wiring-Drive Motor	5-67
Wiring Diagram	5-69
Suggested Spare Parts	5-70
Accessory Pump-Option	5-71
Back-Up Alarm-Option	5-73
Dual Vacuum Motor-Option	5-75
Warning Light-Option	5-77
EC Declaration of Conformity	5-79
Serial Numbers	5-82
Warranty	

HOW TO USE THIS MANUAL

This manual contains the following sections:

- HOW TO USE THIS MANUAL
- SAFETY
- OPERATIONS
- MAINTENANCE
- PARTS LIST

The HOW TO USE THIS MANUAL section will tell you how to find important information for ordering correct repair parts.

Parts may be ordered from authorized Windsor dealers. When placing an order for parts, the machine model and machine serial number are important. Refer to the MACHINE DATA box which is filled out during the installation of your machine. The MACHINE DATA box is located on the inside of the front cover of this manual.

MODEL _____
DATE OF PURCHASE _____
SERIAL NUMBER _____
SALES REPRESENTATIVE # _____
DEALER NAME _____
OPERATIONS GUIDE NUMBER _____
PUBLISHED _____

Copyright 2002 Windsor Industries, Printed in USA

The model and serial number of your machine are located to the front of the battery compartment for the machine.

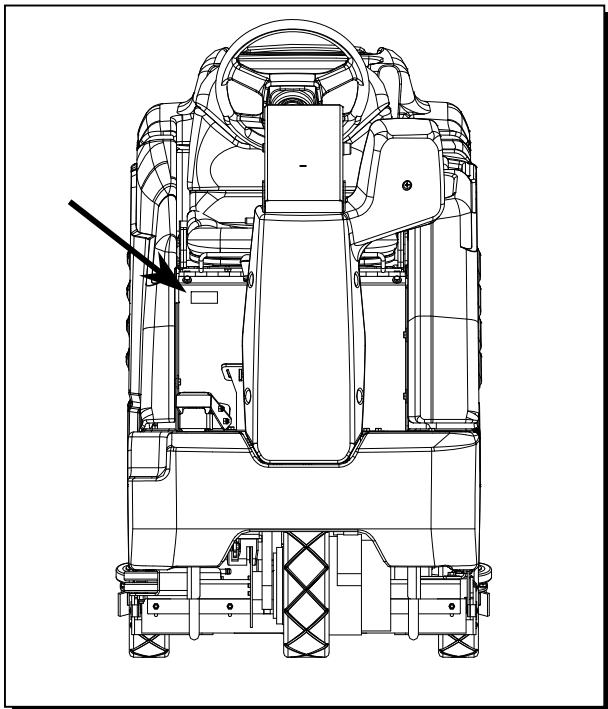

The SAFETY section contains important information regarding hazard or unsafe practices of the machine. Levels of hazards are identified that could result in product or personal injury, or severe injury resulting in death.

The OPERATIONS section is to familiarize the operator with the operation and function of the machine.

The MAINTENANCE section contains preventive maintenance to keep the machine and its components in good working condition. They are listed in this general order:

- Batteries
- Scrub Brushes
- Adjusting Squeegee
- Service Schedule
- Machine Troubleshooting

The PARTS LIST section contains assembled parts illustrations and corresponding parts list. The parts lists include a number of columns of information:

- **REF** – column refers to the reference number on the parts illustration.
- **PART NO.** – column lists the part number for the part.
- **PRV NO.** – reference number
- **QTY** – column lists the quantity of the part used in that area of the machine.
- **DESCRIPTION** – column is a brief description of the part.
- **SERIAL NO. FROM** – If this column has an (*) and a Reference number, see the SERIAL NUMBERS page in the back of your manual. If column has two asterisk (**), call manufacturer for serial number. The serial number indicates the first machine the part number is applicable to. The main illustration shows the most current design of the machine. When a boxed illustration is shown, it displays the older design.
- **NOTES** – column for information not noted by the other columns.

NOTE: If a service or option kit is installed on your machine, be sure to keep the KIT INSTRUCTIONS which came with the kit. It contains replacement parts numbers needed for ordering future parts.

NOTE: The number on the lower left corner of the front cover is the part number for this manual.

IMPORTANT SAFETY INSTRUCTIONS

When using an battery powered appliance, basic precaution must always be followed, including the following:

READ ALL INSTRUCTIONS BEFORE USING THIS MACHINE.



WARNING:

To reduce the risk of fire, electric shock, or injury:

Use only indoors. Do not use outdoors or expose to rain.

Use only as described in this manual. Use only manufacturer's recommended components and attachments.

If the machine is **not working properly**, has been dropped, damaged, left outdoors, or dropped into water, return it to an authorized service center.

Do not operate the machine with any openings blocked. Keep openings free of debris that may reduce airflow.

This machine **is not** suitable for picking up hazardous dust.

Machine can cause a fire when operating near flammable vapors or materials. Do not operate this machine near flammable fluids, dust or vapors.

This machine is suitable for commercial use, for example in hotels, schools, hospitals, factories, shops and offices for more than normal housekeeping purposes.

Maintenance and repairs **must be done** by qualified personnel.

If foam or liquid comes out of machine, **switch off immediately**.

Disconnect battery before cleaning or servicing.

Before the machine is discarded, the batteries **must be removed** and properly disposed of.

Make sure all warning and caution labels **are legible and properly attached** to the machine.

During operation, attention shall be paid to other persons, especially children.

Before use all covers and doors shall be put in the positions specified in the instructions.

When leaving unattended, secure against unintentional movement.

The machine shall only be operated by instructed and authorized persons.

When leaving unattended, switch off or lock the main power switch to prevent unauthorized use.

Only chemicals recommended by the manufacturer shall be used.

This appliance has been designed for use with the brushes specified by the manufacturer. The fitting of other brushes may affect its safety.

SAVE THESE INSTRUCTIONS

HAZARD INTENSITY LEVEL

The following symbols are used throughout this guide as indicated in their descriptions:

HAZARD INTENSITY LEVEL

There are three levels of hazard intensity identified by signal words -**WARNING** and **CAUTION** and **FOR SAFETY**. The level of hazard intensity is determined by the following definitions:

⚠ WARNING

WARNING - Hazards or unsafe practices which COULD result in severe personal injury or death.

⚠ CAUTION

CAUTION - Hazards or unsafe practices which could result in minor personal injury or product or property damage.

FOR SAFETY: To identify actions which must be followed for safe operation of equipment.

Report machine damage or faulty operation immediately. Do not use the machine if it is not in proper operating condition. Following is information that signals some potentially dangerous conditions to the operator or the equipment. Read this information carefully. Know when these conditions can exist. Locate all safety devices on the machine. Please take the necessary steps to train the machine operating personnel.

FOR SAFETY:

DO NOT OPERATE MACHINE:

Unless Trained and Authorized.

Unless Operation Guide is Read and understood.

In Flammable or Explosive areas.

In areas with possible falling objects.

WHEN SERVICING MACHINE:

Avoid moving parts. Do not wear loose clothing; jackets, shirts, or sleeves when working on the machine. Use Windsor approved replacement parts.

⚠ WARNING

Batteries emit hydrogen gas. Explosion or fire can result. Keep sparks and open flame away. Keep solution tank in raised position when charging. Keep sparks and flames away from the batteries. Do not smoke around batteries.

⚠ WARNING

Disconnect batteries before working on machine. Only qualified personnel should work inside machine. Always wear eye protection and protective clothing when working on or near batteries. Avoid skin contact with the acid contained in the batteries.

⚠ WARNING

Never allow metal to lie across battery tops.

SAFETY LABEL LOCATION

NOTE: These drawings indicate the location of safety labels on the machine. If at any time the labels become illegible, promptly replace them.



SAFETY DECAL
86252530
PRV NO. 81494

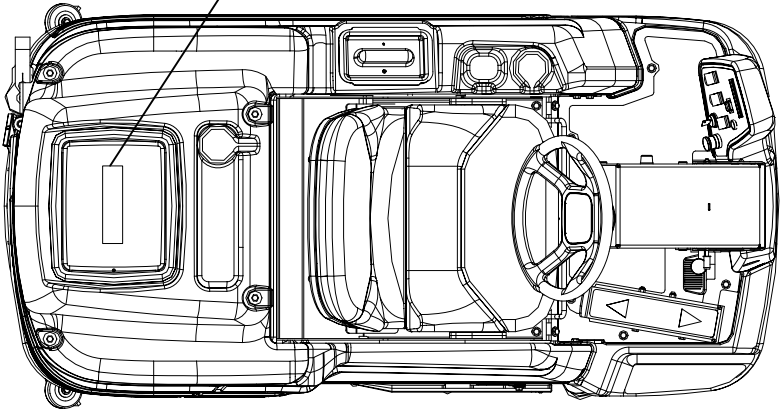

BATTERY CAUTION
86252520
PRV NO. 80885

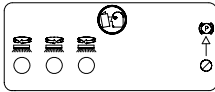

CIRCUIT BREAKER
86244130
PRV. NO 500859 - 28 IN & 32 IN
86244140
PRV NO. 500861 - 36 IN

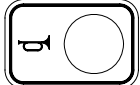

HORN DECAL
86248210
PRV NO. 81349

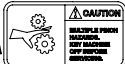
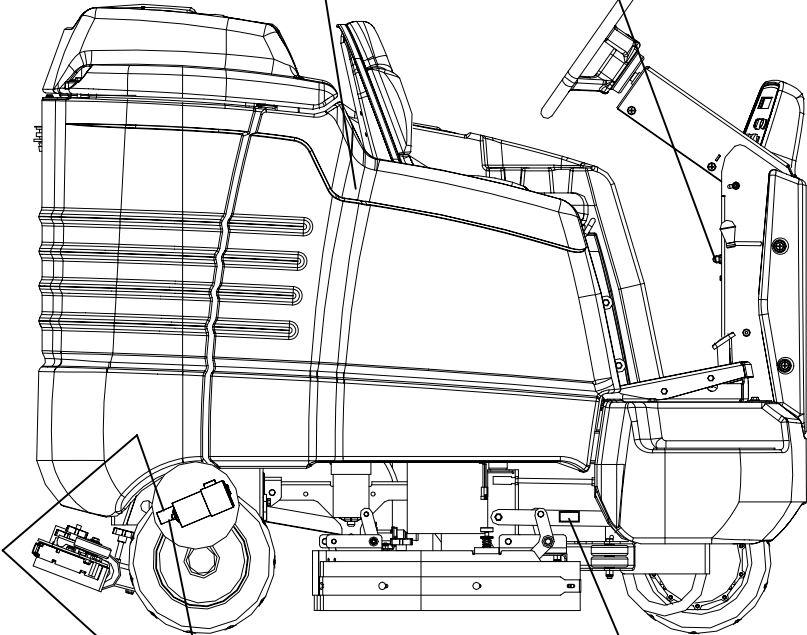

PINCH POINT WARNING
86243830
PRV NO. 500663



PINCH POINT WARNING
86243830
PRV NO. 500663 (2)
* 36 IN MODEL ONLY

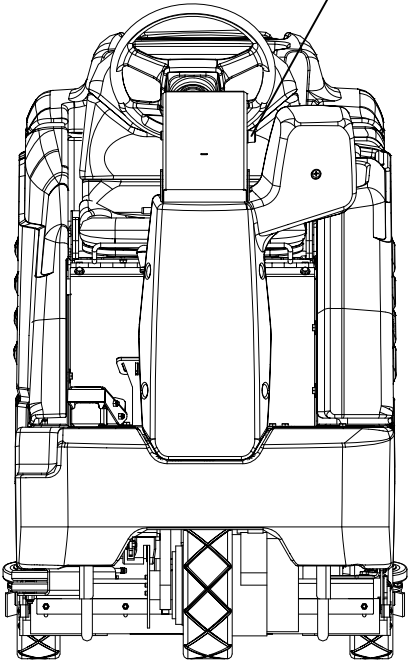

TECHNICAL SPECIFICATIONS

ITEM	DIMENSION/CAPACITY
Nominal power	2.9 kW
Rated Voltage	36 Volts DC
Rated Amperage	80 amps (28in & 32in) 95 amps (36in)
Batteries	6 x 6 Volt 250-335 AH @20 hr. rate
Scrub Brush Motors	2 x 1.0 HP (746 W) 28in & 32in 3 x 1.0 HP (746 W) 36in
Vacuum Motor(s)	1 x .75 HP (560 W) Standard, second motor optional
Propelling Motor	1.3 HP (1000 W)
Mass (GVW)	1810 lbs (820 kg) 28in & 32in 1840 lbs (835kg) 36in
Weight empty without batteries	790 lbs (360 kg) 28in & 32in 825 lbs (375 kg) 36in
Solution Control	Gravity feed, fully variable with automatic shut off in neutral
Solution tank capacity	30 gal (115 L)
Recovery tank capacity	30 gal (115 L)
Scrub brush diameter for 28 in. (71 cm) disk scrub head	14 inch (35.5 cm)
Scrub brush diameter for 32 in. (81 cm) disk scrub head	16 inch (40.6 cm)
Scrub brush diameter for 36 in. (91 cm) disk scrub head	12 inch (30.5 cm)
Scrub brush pressure	0-225 lbs (0-1000N) 28in & 32in 0-150 lbs (0-667N) 36in
Scrub brush speed	300 rpm
Tires – Front – Rear	11.8 in. (30.0cm) Solid Polyurethane 12 in. (30.5 cm) Solid Scrubber Compound
Foundation Pressure	108 lbs./in ² (745 kPa)
Maximum Speed	4.1 miles/hour (6.5 Km/hour)
Frame Construction	Powder coated steel
Brakes	Mechanical band with hand lock parking brake
Minimum aisle u-turn width with 28 in. (71 cm), 32 in. (81 cm) or 36 in. (91 cm) disk scrub head	66 inches (168 cm)
Maximum rated climb and descent angle	7.5 degrees

TECHNICAL SPECIFICATIONS

ITEM	MEASURE
Height 1	51 inches (130 cm)
Height 2	56.6 inches (144 cm)
Length	63.5 inches (161 cm)
Width without squeegee and scrub head	31 inches (79 cm)
Width of squeegee	33 inches (84 cm)
Width of scrub path for 28 in. (71 cm)	28 inches (71 cm)
Width of scrub path for 32 in. (81 cm)	32 inches (81 cm)
Width of scrub path for 36 in. (91 cm)	28-36 inches (71-91 cm)

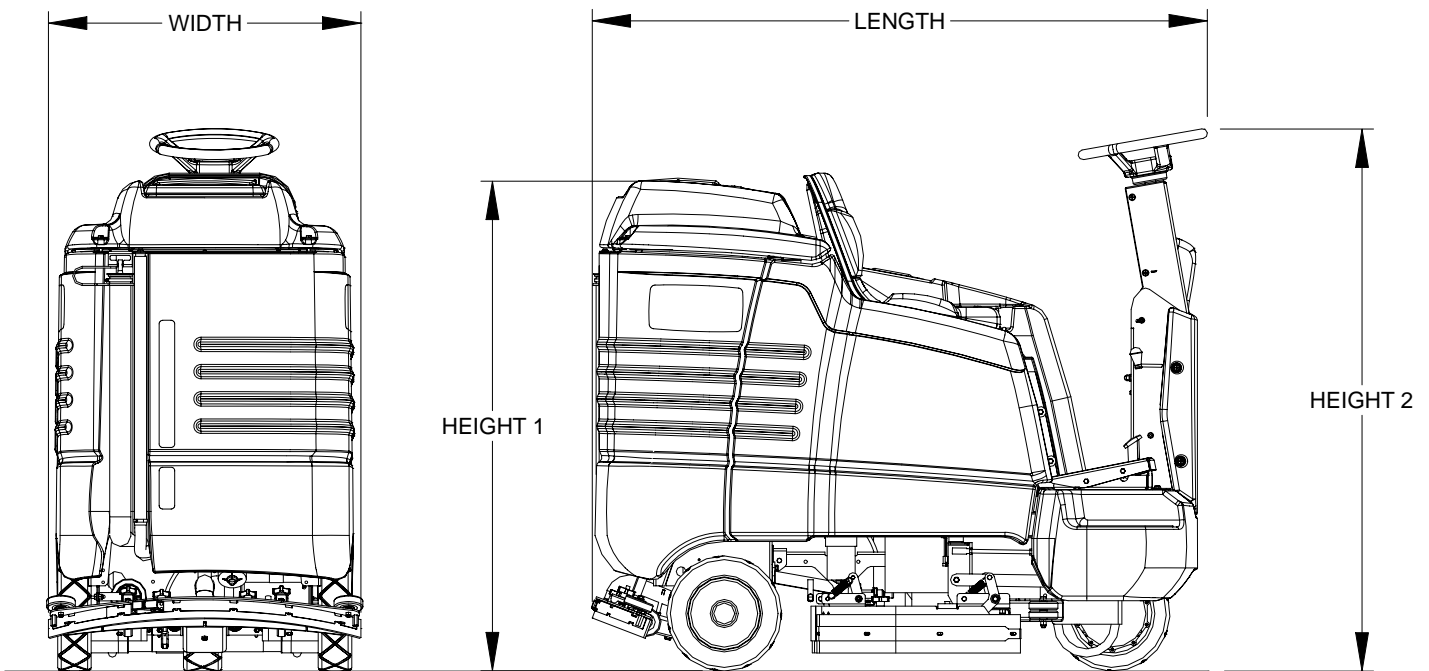

SPECIAL NOTES:

The sound pressure level at the operator's ear was measured to be 72.3 dBA. This was a nearfield, broad-band measurement taken in a typical industrial environment on a tile floor. This appliance contains no possible source of impact noise. The instantaneous sound pressure level is below 63 Pa.

The weighted root mean square acceleration at the operator's arms was measured to be below 2.5m/s^2 . This was a tri-axial, third-octave-band measurement made during normal operation on a composite tile floor. The measurement and related calculations were made in accordance with ANSI S3.34-1986.

HOW THE MACHINE WORKS

The Saber Glide is a battery powered, self-propelled, hard floor scrubber intended for commercial use. The appliance applies a cleaning solution onto a hard floor, scrubs the floor with brushes, and then vacuums the soiled water back into the recovery tank.

The machine's primary systems are the solution system, scrub system, recovery system, and operator control system.

The function of the solution system is to store cleaning solution and deliver it to the scrub system. The solution system consists of the solution tank, strainer, valve and controls. The solution tank stores cleaning solution (water and detergent) until it is delivered to the scrub system. The strainer protects the valve from debris. The valve is a solenoid type valve, which controls the delivery of cleaning solution to the scrub system. The valve automatically prevents solution flow unless the scrub brushes are turned on and the machine is being propelled. The solution control switch controls the amount of cleaning solution delivered to the scrub system by controlling the amount of time the valve is open.

The function of the scrub system is to scrub the floor.

The 28 in. and 32 in. disk scrub systems consists of two rotary type disk scrub brushes, motors, scrub deck skirt, lift actuator and controls. The brushes scrub the floor as the motors drive the brushes. The brush drive hubs allow the scrub brushes to follow irregularities and changes in the floor without losing contact with the floor. The scrub deck skirts and side squeegees control the cleaning solution on the floor so that the squeegee can pick it up. The one touch switch controls the motors and lift actuator to turn the motors on and lower the deck, or turn the motors off and raise the deck. The brush pressure switch controls the down pressure on the scrub deck.

The 36 in. disk scrub system consists of three rotary type disk scrub brushes, motors, scrub deck skirts, lift actuator, shift actuator and controls. The brushes scrub the floor as the motors drive the brushes. The brush drive hubs allow the scrub brushes to follow irregularities and changes in the floor without losing contact with the floor. The scrub deck skirts and side squeegees control the cleaning solution on the floor so that the squeegee can pick it up. The one touch switch controls the motors and lift actuator to turn the motors on and lower the deck, or turn the motors off and raise the deck. The brush pressure switch controls the down pressure on the scrub deck. The scrub deck shift switch controls the position of the retractable scrub deck.

The function of the recovery system is to vacuum the soiled water back into the recovery tank. The recovery system consists of the squeegee, vacuum motor, filter, recovery tank and controls. The squeegee wipes the dirty solution off the floor as the machine moves forward. The vacuum motor provides suction to draw the dirty solution off the floor and into the recovery tank. The filter protects the vacuum fan from debris and foam. The recovery tank stores the dirty solution.

The float switch in the tank activates the recovery tank full indicator, shuts off the scrub motors and solution flow, raises the scrub deck then squeegee, and shuts off vacuum motor.

The function of the operator control system is to control the direction and speed of the machine. The directional control system consists of the direction/speed control pedal, steering wheel, brake pedal, propel controller, and drive wheel. The direction/speed pedal signals forward or reverse direction and speed. The controller interprets signals from the direction/speed pedal to command the drive wheel to propel or slow the machine. The steering wheel points the drive wheel in the direction desired by the operator. The brake can be used to hold the machine on slopes.

COMPONENTS

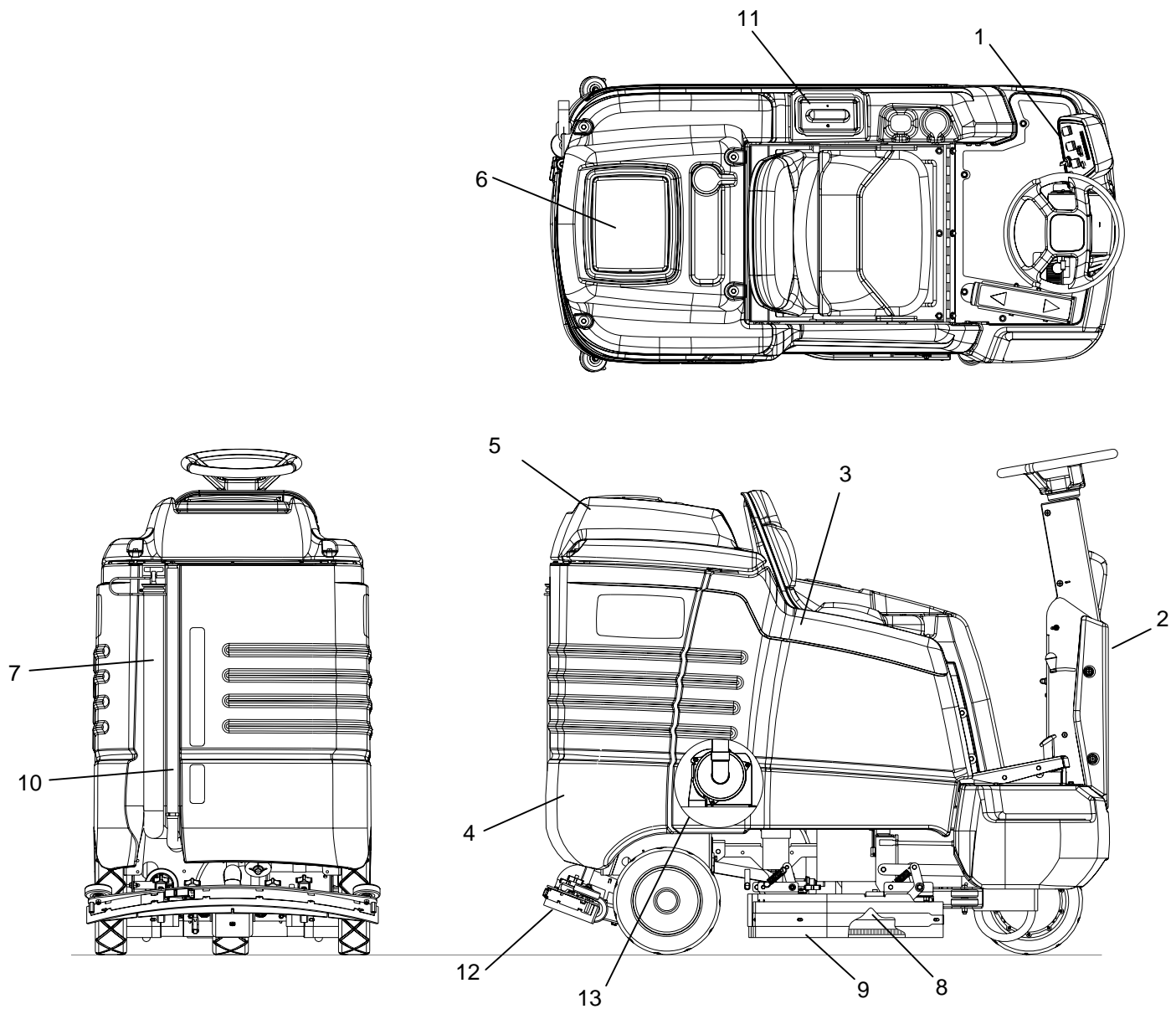

- 1. Control panel
- 2. Front cover
- 3. Side cover
- 4. Tank
- 5. Recovery tank cover
- 6. Recovery tank dome
- 7. Recovery tank drain hose
- 8. Scrub head
- 9. Scrub head side squeegee
- 10. Solution tank drain hose
- 11. Solution tank cover
- 12. Squeegee
- 13. Vacuum motor

CONTROLS

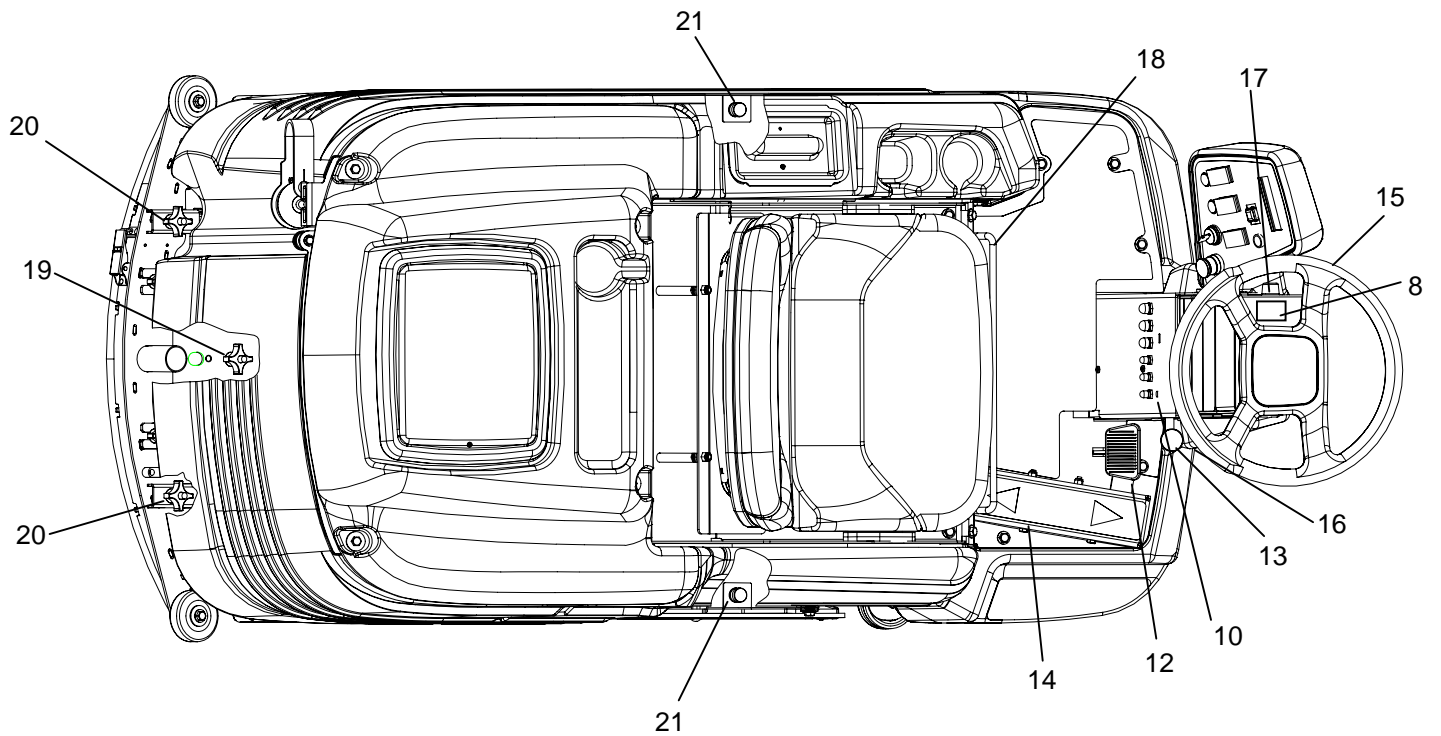
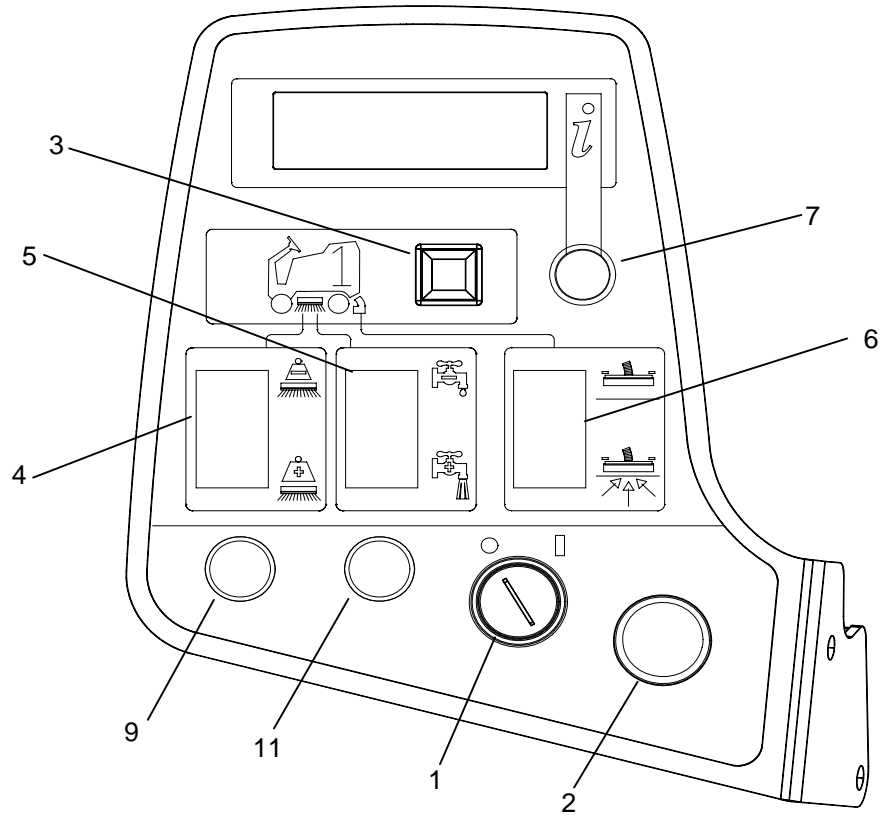

1. Key switch
2. Emergency stop button
3. One touch switch
4. Brush pressure switch
5. Solution control switch
6. Vacuum/squeegee switch
7. Display toggle switch
 - Information Screen 1
 - Information Screen 2
 - Hour meter
 - Fault codes and special icons
 - Battery meter
8. Scrub Deck Shift Switch (36in only)
9. Recycle switch (optional)
10. Recycle indicator light (optional)
11. Headlight switch (optional)
12. Brake pedal
13. Parking brake lever
14. Directional control pedal and speed reduction feature.
15. Steering wheel
16. Steering tilt lever
17. Horn button
18. Seat adjustment grab bar
19. Squeegee camber adjustment knob
20. Squeegee deflection adjustment knob
21. Side squeegee deflection adjustment knob

1. KEY SWITCH

Controls the power for the machine functions. To turn the machine power on, rotate key clockwise. When the key is turned on the battery symbol will flash for 12 seconds while the system runs self-diagnostics and returns scrub deck and squeegee to raised position, if necessary. The controller will not respond to other commands until this routine is complete. To turn the machine power off, rotate key counterclockwise.

INFORMATION DISPLAY

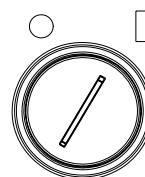

2. EMERGENCY STOP BUTTON

This safety feature is designed to cut all power to the machine at any time. To shut the machine power off, push the Emergency Stop switch. To reset the machine, rotate the switch clockwise.

INFORMATION DISPLAY

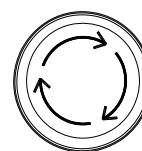
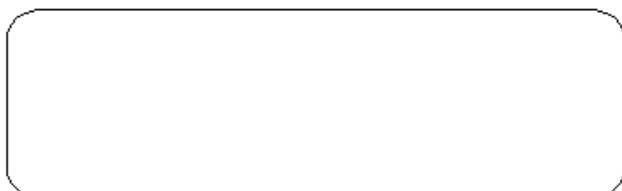

CONTROLS

3. ONE TOUCH SWITCH

This switch controls the scrub brushes and vacuum all in one touch.

To start scrubbing, press the one touch switch. The brush drive motors will turn on, the scrub deck will lower to the "light scrub" position, the solution will flow at "two bars" rate, the squeegee will lower and the vacuum will turn on. The information display window will show which functions are operating. If the direction control pedal is in the neutral position for more than two seconds the brushes and solution flow will stop. If the one touch switch is activated without brushes installed, the brush motors will stop, the scrub deck will rise, and the brush pressure indicator will display error code 9000. To stop scrubbing, press the one touch switch. The brush drive motors will turn off, the scrub deck will raise the solution flow will stop, the squeegee will raise after a 15 second delay, and the vacuum motor will turn off. This delay is to clear the vacuum hose of recovered solution.

INFORMATION DISPLAY

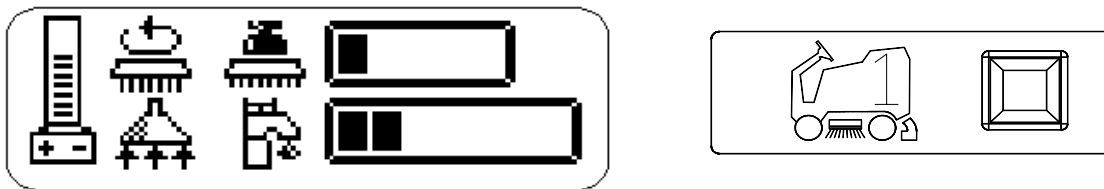

4. BRUSH PRESSURE SWITCH

This switch controls the amount of brush pressure to the floor. There are 5 different pressure settings. To decrease the amount of down pressure, press the top of the brush pressure switch (-). To increase the amount of down pressure, press the bottom of the brush pressure switch (+). The information display screen will show the amount of pressure.

NOTE: Press switch and hold momentarily each time to change brush pressure.

INFORMATION DISPLAY

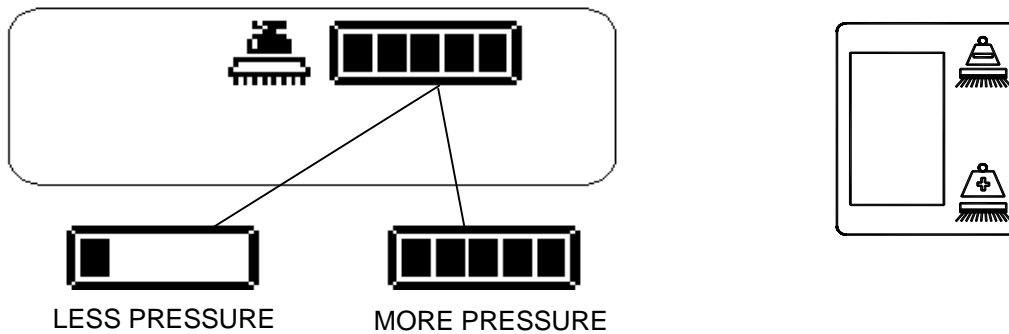

5. SOLUTION CONTROL SWITCH

This switch controls the amount of solution flow to the scrub deck. There are 7 different flow settings. To increase the solution flow, press the solution control switch (+). To decrease solution flow, press the top of the switch (-). If the brush motors are turned off or the direction control pedal is in neutral, the flow is automatically interrupted until the motors are turned on again, or the drive pedal is moved forward or reverse. This feature prevents unintentional draining of the solution tank and allows the operator to adjust the solution flow to the scrub deck without resetting each time the scrubbing operation is interrupted. If recycling option is installed, this switch controls the amount of solution flow to the scrub deck by controlling the speed of the pump.

NOTE: Press switch and hold momentarily each time to change solution flow.

INFORMATION DISPLAY

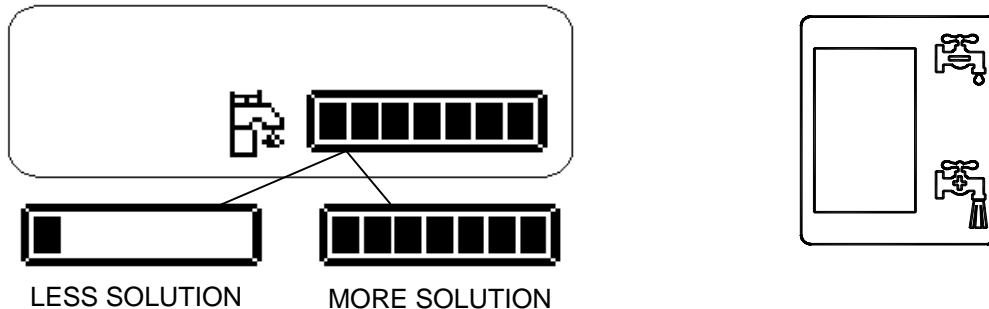

6. VACUUM/SQUEEGEE SWITCH

This switch independently controls the vacuum motor and squeegee position. To start the vacuum motor and lower the squeegee to the floor, press the bottom of the switch. To raise the squeegee and turn off the vacuum motor, press the top of the switch. The squeegee will raise after a 15 second delay, and the vacuum motor will turn off 15 seconds later, in order to clear vacuum hose of recovered solution.

INFORMATION DISPLAY

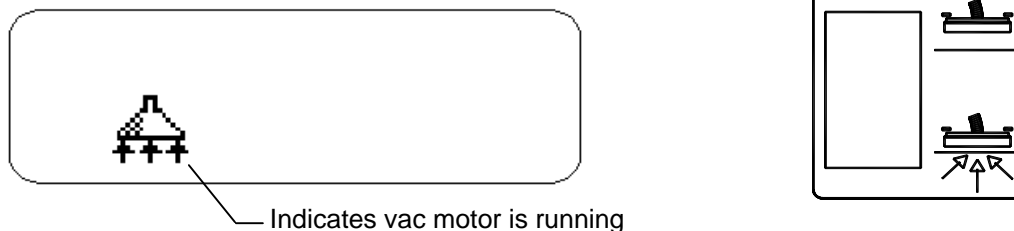

CONTROLS

7. DISPLAY TOGGLE SWITCH

The display toggle switch allows you to change the information display screen. Two screens are available.

- INFORMATION DISPLAY –SCREEN 1

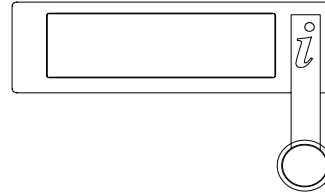

- INFORMATION DISPLAY –SCREEN 2
- The hour meter is viewed on screen 2 of the information display. Hours are displayed for key ON time, brush run time, and traction motor time.

 A rounded rectangular frame containing a battery icon, a brush motor icon, and three digital displays. The top display shows '00000.0' with a key icon to its right. The middle display shows '00000.0' with a brush motor icon to its right. The bottom display shows '00000.0' with a traction motor icon to its right. Lines connect these icons to text descriptions on the right.

Key ON Hours:
Records the entire time that the key is on.

Brush Run Time:
Records the time spent with the brushes running and gives true brush motor time.

Traction Motor Time:
Records the time spent propelling the machine and gives true traction motor time.

- Fault codes/icon will appear on either display screen when the controller detects a problem within the electrical system. The codes/icons are used to assist users as well as service technicians in identifying and correcting problems. See troubleshooting section for more information on fault codes. The machine must be keyed off, then on again, to clear fault code after repair.

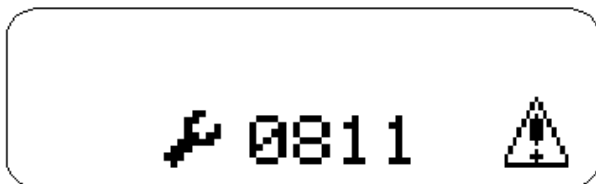

- Icon appears if throttle is depressed when the key is turned on. To correct, lift foot off of throttle. If this does not clear the icon, the throttle may be damaged and should be checked by a qualified service technician.



- The float switch is located inside the recovery tank. The purpose of the float switch is to notify the user that the recovery tank is full. When the float switch is activated, the scrub brush motors and solution flow will stop, the scrub deck will raise, the squeegee will rise after 60 seconds, and the vacuum motor will turn off 10 seconds later.



- The battery meter can be viewed at the left side of either information screen 1 or information screen 2. The level of battery charge is indicated by the horizontal bars in the battery meter box. When the batteries require charging, the icon will flash and a battery inhibit icon will appear on the right side of either information screen. Scrub and solution functions that are running when the battery inhibit icon appears will be automatically shut off. It is not possible to restart scrub functions while the battery inhibit is displayed. The controller reserves enough battery charge to allow pick-up of residual water and transport back to a charging station.



8. SCRUB DECK SHIFT SWITCH (36 IN ONLY)

- This switch controls the position of the retractable scrub deck. To extend the scrub deck, press and hold the top of the switch. To retract the scrub deck, press and hold the bottom of the switch.



CONTROLS

9. RECYCLE SWITCH (OPTIONAL)

This switch controls the solution recycle pump. To start recycle pump, press the switch. A green light above the circuit breakers will indicate that pump is on. The solution control switch will control the speed of the pump and therefore the amount of solution flow to the scrub deck. Make sure there is an adequate amount of water in recovery tank before starting recycle pump, and turn off recycle pump when water level reaches filter. To stop the solution recycle pump, press the switch. The pump will stop and the green indicator light will turn off, and the solenoid valve will resume control of solution flow to the scrub deck.



10. RECYCLE INDICATOR LIGHT (OPTIONAL)

This light will turn on when the recycle pump is on, and turn off when the recycle pump is off.



11. HEADLIGHT SWITCH (OPTIONAL)

Turns on optional headlight for improved visibility in low light areas.



12. BRAKE PEDAL

The brake pedal is located on the floor to the right side of the steering column pedestal. The pedal operates the disc brake on the drive wheel. To slow or stop the vehicle, apply pressure to the brake pedal.

13. PARKING BRAKE LEVER

The black knob located on the right side of the steering column pedestal is used to set the parking brake. To set the parking brake, fully depress the brake pedal and push the parking brake knob. To release the parking brake, fully depress the brake pedal. Then release pressure on the brake pedal. The parking brake knob will return it to its' released position.

FOR SAFETY: Before leaving or servicing machine; stop on level surface, set parking brake, turn off machine and remove key.



14. DIRECTIONAL CONTROL PEDAL AND SPEED REDUCTION FEATURE

This pedal controls the direction of travel and the speed of the vehicle. Slowly pressing the front of the pedal causes the machine to travel forward. Pressing the rear of the pedal causes the vehicle to travel in reverse. The vehicle speed can be controlled by varying the pressure on the front or rear of the pedal.

FOR SAFETY: The vehicle can coast for a short distance after releasing the directional pedal. Remove the foot from pedal and use brakes to slow or stop the machine.

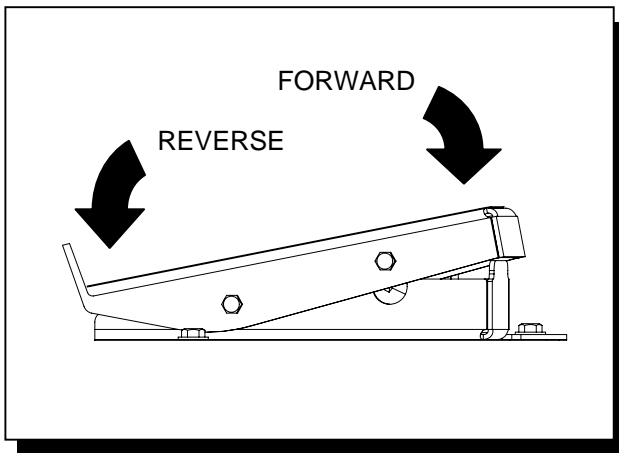

SPEED REDUCTION FEATURE

Maximum speed of machine can be decreased to 80% of maximum by disconnecting wire 3 white from wire 16 white, located between controller and LCD display. Machine is set at 100% speed setting at factory.

CONTROLS

15. STEERING WHEEL

The steering wheel turns the front wheel causing the machine to change direction.

16. STEERING TILT LEVER

The steering tilt lever is located on the right side of the steering wheel. To engage the tilt adjustment, pull on the lever and adjust the steering column to desired position. Release lever and allow it to lock into desired position.

17. HORN BUTTON

The horn button is located on left side of the steering column. The horn is activated by pressing the horn button.

18. SEAT ADJUSTMENT GRAB BAR

The seat adjustment grab bar is located in front of seat at the bottom. While in a standing position, grasp the back of the seat and the seat adjustment grab bar and lift seat into the adjustment slot and lower into one of the locking positions. Adjust the seat to the desired position.

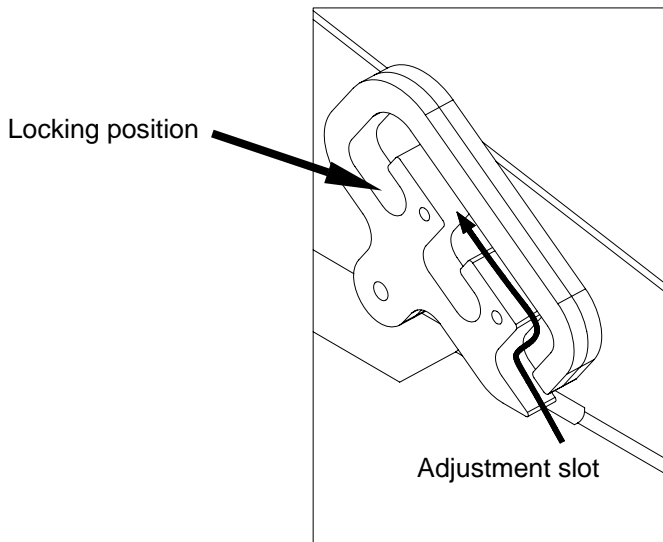

19. SQUEEGEE CAMBER ADJUSTMENT KNOB

The squeegee camber adjustment knob is located at the center of the squeegee at the rear of the machine. (See maintenance section for adjustment).

20. SQUEEGEE DEFECTION ADJUSTMENT KNOB

The squeegee deflection knobs are located at the rear of the machine, one on either side of the squeegee assembly. (See maintenance section for adjustment).

21. SIDE SQUEEGEE DEFECTION ADJUSTMENT KNOB

Side squeegee adjustment knobs are located above the scrub deck. (See maintenance section for adjustment).

PRE-RUN MACHINE INSPECTION

1. Do a pre-run inspection to find possible problems that could cause poor performance or lost time from breakdown. Follow the same procedure each time to avoid missing steps. Visually check for exterior damage, leaks, damaged or worn tires.
2. Check brushes or pads and drivers for proper installation and wear. Weekly check scrub deck skirts for proper contact with floor. See BRUSHES in MAINTENANCE SECTION.
3. Check squeegee for wear and proper adjustment. See SQUEEGEE ADJUSTMENT in MAINTENANCE SECTION.
4. Check for securely attached drain hose, plug, and caps.
5. Check battery condition, recharge if necessary. See BATTERIES in maintenance section.
6. Check the brakes and steering for proper operation. See BRAKES and STEERING in MAINTENANCE SECTION.

STARTING MACHINE

NOTE: Perform pre-run machine check before operating machine.

FOR SAFETY: Before starting machine, make sure that all safety devices are in place and operating properly.

1. The operator should be in the seat with the right foot on the brake pedal or with the parking brake on. The directional pedal must be in the neutral position to avoid unintentional movement.

NOTE: The Operator must be in position on the seat to activate machine in desired direction.

2. Turn the key switch clockwise to the "ON" position.
3. Release the brake, then press lightly on the directional pedal in the desired direction and drive to the filling area.

FILLING THE MACHINE

FOR SAFETY: Before leaving or servicing machine; stop on level surface, set parking brake, turn off machine and remove key.

1. Set squeegee and scrub deck to up position, set parking brake, and turn off key switch.
2. Remove solution tank cover.



WARNING

Flammable materials can cause an explosion or fire.

Do not use flammable materials in the tanks.

3. The solution tank can be filled to the FULL marking of the fill inlet. Leave room for detergent. The solution tank capacity is 30 gallons (114 liters). The water must not be hotter than 140° (60°C) to prevent damage to the tank. Measure the required amount of chemical into the solution tank after filling with water. Dry chemicals should be thoroughly mixed before being added into solution tank. Commercially available, high alkaline floor cleaners are suitable for use in the solution system.
4. Inspect solution tank cover vent for obstructions. Replace solution tank cover.

SCRUBBING

Plan the scrubbing pattern in advance. The longest track is around the perimeter of the area to be cleaned. For efficient operation, the runs should be the longest possible without turning, stopping, or raising or lowering scrub deck/squeegee.

In order to achieve the best possible results, the area which is to be cleaned should be swept before scrubbing. Large debris, strings and wire must be removed to prevent being caught in brushes or squeegee.

The machine will automatically raise the squeegee slightly when reverse travel is selected. If the machine is allowed to stand in neutral with the scrub deck down for more than 2 seconds, the solutions flow stops and brush motors stop. If either forward or reverse travel is selected, the solution flow will continue in the same setting and the scrub brush motors will continue in their same setting once movement of machine begins. Overlap the brush path and avoid transporting over previously cleaned areas.

INEFFICIENT SCRUBBING PATH

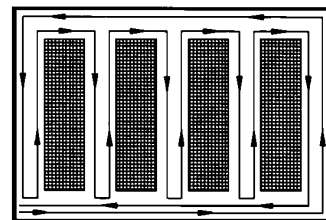

RECOMMENDED SCRUBBING PATH

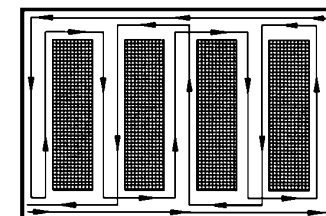

MACHINE OPERATION

TO BEGIN SCRUBBING

⚠ CAUTION When operating the machine around people, pay close attention for unexpected movement. Use extra caution around children.

1. Place right foot on brake pedal or check to make sure parking brake has been set.
2. With directional pedal in neutral turn key switch to "ON".
3. Release brake.
4. Press the directional pedal to travel in the desired direction and steer to the start of the scrub pattern.
5. Press the one-touch switch (#1) on the control panel. The brush motors will start, the scrub deck will lower to the light scrub position, the solution will begin to flow, the squeegee will lower to the floor and the vacuum motors will start.
6. Adjust the speed of the machine, solution flow and scrub brush pressure as necessary.

NOTE: Once solution flow rate is set it is not necessary to shut off solution when stopping scrubbing. Solution flow is automatically shut off when brush motors stop. When brush motors are activated, flow automatically resumes.

⚠ WARNING Flammable liquids and/or reactive metals can cause explosions or fire! Do not pick up.

TO STOP SCRUBBING

1. Press the one-touch switch (#1) on the control panel. The brush motors will stop and the scrub deck will raise to the park position. After 15 seconds, the squeegee will raise, and 15 seconds later the vacuum motor will turn off. This delay is to clear the vacuum hose of recovered solution.
2. Allow directional pedal to return to neutral.
3. Apply brake to stop machine.
4. Turn key switch off.
5. Set parking brake.

FOR SAFETY: Before leaving or servicing machine; stop on level surface, set parking brake, turn off machine and remove key.

EMERGENCY STOP PROCEDURE

1. Turn key switch to off position. If an electrical problem is suspected push in emergency stop button.
2. Release pressure on directional pedal.
3. Apply brakes.

NOTE: Turning the key switch off during normal running operation will stop all motors and actuators. When the key is turned back on the system will automatically return scrub deck and squeegee to raised position.

DOUBLE SCRUB

Floors which are heavily soiled or have thick accumulation of floor finish may not clean sufficiently with one pass. In these cases it will be necessary to double scrub.

To double scrub, make the first pass over the surface being cleaned with the squeegee up, the solution on, and brushes down. This allows the solution to stay in contact with the soil while loosening the surface accumulation with the brushes. Allow time for the first application to stay in contact with floor. Length of time between the first and second pass depends on amount of accumulation and the type of chemical being used. A second scrubbing with the squeegee down and again the solution and brushes on will further loosen soil. The additional application of solution will further assist the difficult cleaning job. Caution should be used when double scrubbing, maintain safe driving speed on wet floors.

EMPTYING AND CLEANING TANKS

RECOVERY TANK

1. Touch the one-touch switch (#1) on the control panel to raise the scrub deck, stop the motors, and solution flow, raise the squeegee and turn off vacuum motors.
2. Park the machine next to a floor drain. Drain hose is on left rear corner of machine.
3. Turn off the key switch and set the machine's parking brake.
4. Unhook the drain hose from retainer. Unscrew T-handle on plug enough to loosen plug and lower hose in direction of drain. Stand behind end of hose. Recovered solution will come out with force. Slowly remove plug from drain hose.
5. Remove recovery tank dome.
6. Flush the recovery tank out with clean water. Repeat until clean water comes out of drain hose. Do not use water hotter than 140° (60°C) to clean the tank. Damage to tank may occur.
7. Replace plug and secure drain hose in bracket.
8. If machine is to be stored, leave recovery tank dome open and drain hose plug off.

SOLUTION TANK

1. Park the machine next to a floor drain. Drain hose is on left rear adjacent to recovery tank drain hose.
 2. Turn off the key switch and set the machine's parking brake.
 3. Unhook the small drain hose from the retainer. Lower hose in direction of the drain.
 4. Remove the solution tank cover.
 5. Flush the solution tank out with clean water and run several gallons of clean water through systems. Do not use water hotter than 140° F (60° C) to clean tank. Damage may occur.
- NOTE:** Never allow solution to remain in tank. Damage to tank, seals and valves could occur.
6. Secure drain hose in bracket.

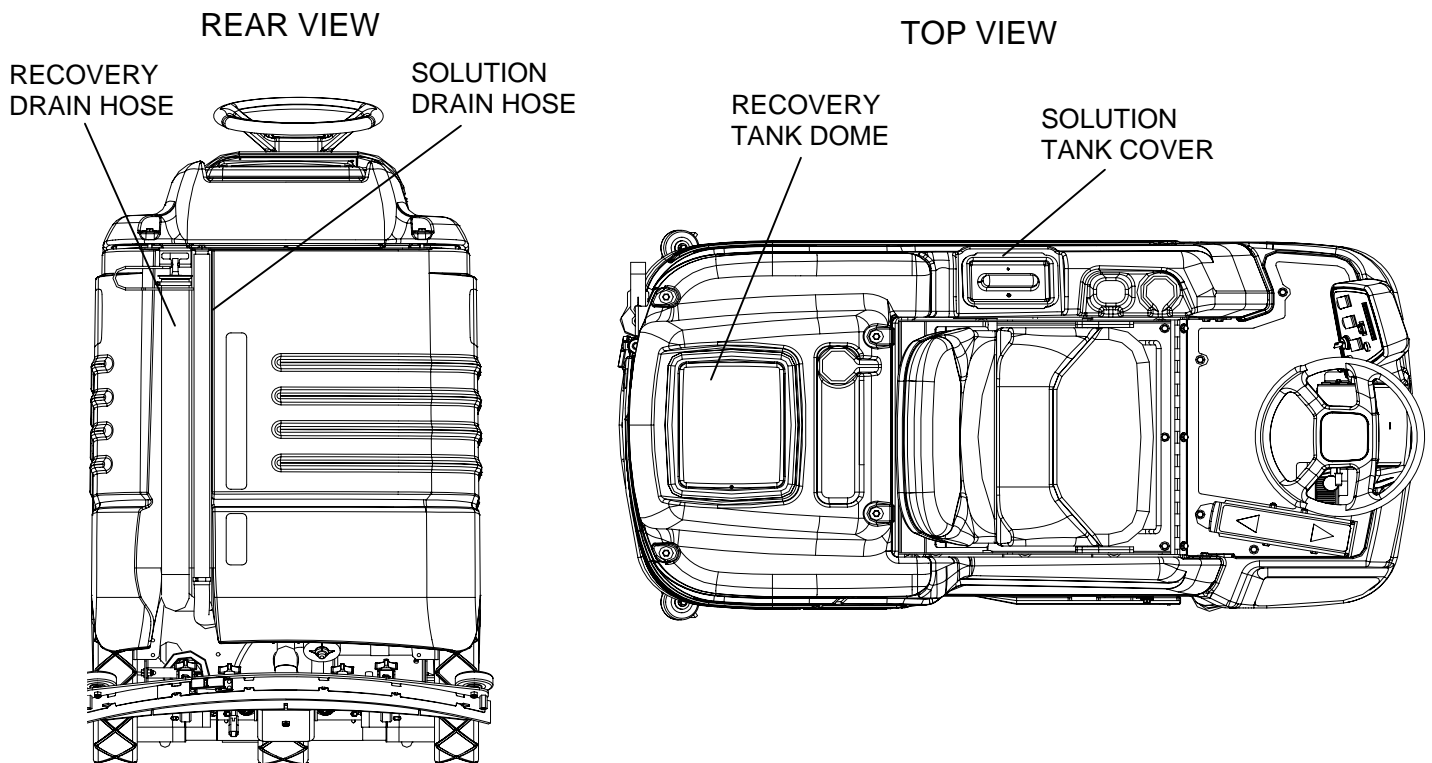

MAINTENANCE

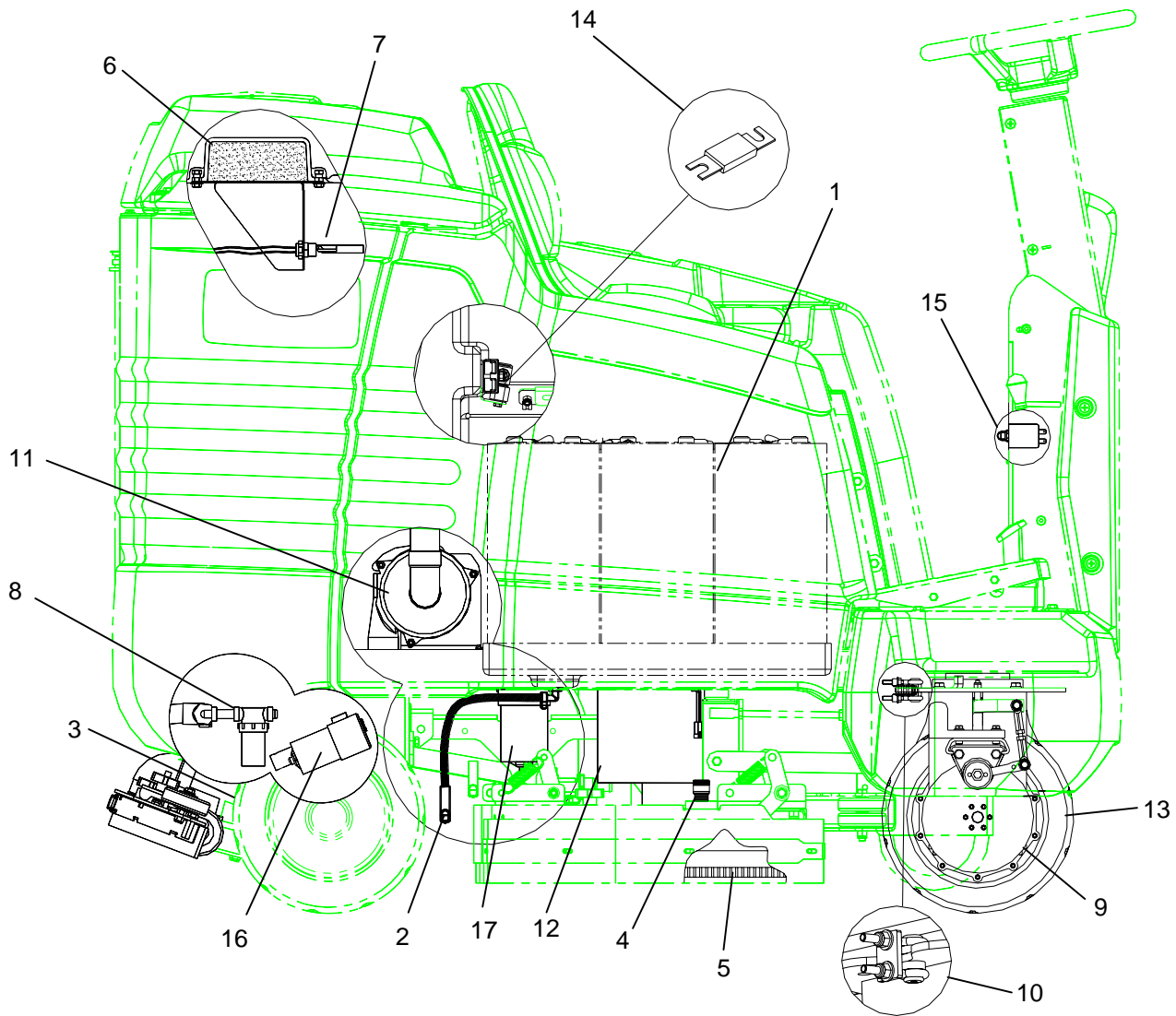

- | | |
|-----------------------------|------------------------------|
| 1. Batteries | 9. Brake |
| 2. Battery Tray Drain Hose | 10. Steering Chain Tensioner |
| 3. Squeegee Adjustment | 11. Vacuum Motor |
| 4. Side Squeegee Adjustment | 12. Brush Motor |
| 5. Scrub Brushes | 13. Traction Motor |
| 6. Vacuum Filter | 14. Fuse |
| 7. Float Switch | 15. Circuit Breaker |
| 8. Solution Strainer | 16. Squeegee Lift Actuator |
| | 17. Scrub Lift Actuator |

1. BATTERIES

The batteries provide the power to operate the machine. The batteries require regular maintenance to keep them operating at peak efficiency.

To get the greatest life from the batteries charge them when their charge level reaches 25% of a full charge. Use a hydrometer to check the charge level.

Do not allow the batteries to remain in a discharged condition for any length of time. Never expose a discharged battery to temperatures below freezing. Discharged batteries will freeze causing cracked case. Do not operate the machine if the batteries are in poor condition or if they have a charge level below 25%, specific gravity below 1.177.

Keep all metallic objects off the top of the batteries, as they may cause a short circuit. Replace worn or damaged cables and terminals.

Check the electrolyte level in each battery cell before and after charging the batteries. Never add acid to the batteries, use water. Do not allow water level to fall below the battery plates. Portions of plates exposed to air will be destroyed. Do not overfill. Keep plugs firmly in place at all times.

⚠ WARNING When servicing machine, avoid contact with acid.

⚠ WARNING Batteries emit hydrogen gas. Explosion or fire can result. Keep sparks and open flame away. Keep covers open when charging.

⚠ WARNING Wear eye protection and protective clothing when working with batteries.

⚠ WARNING Charge batteries in a well ventilated area.

BATTERY MAINTENANCE

1. When cleaning the batteries, use a solution of baking soda and water. Do not allow the cleaning fluid to enter the battery cells. Electrolyte will be neutralized.
2. Maintain the proper electrolyte level in each battery cell. If a cell should accidentally overflow, clean immediately.
3. Do not add water until the battery is fully charged.
4. Wipe off the top of the batteries at least once a week.
5. Test battery condition with a hydrometer at least once a week.

6. Ensure that all connections are tight and all corrosion removed.
7. Every 4 to 6 months, remove the batteries from the machine and clean the battery cases and battery compartment.

NOTE: Do not take readings immediately after adding water. If the water and acid are not thoroughly mixed, the reading may not be accurate.

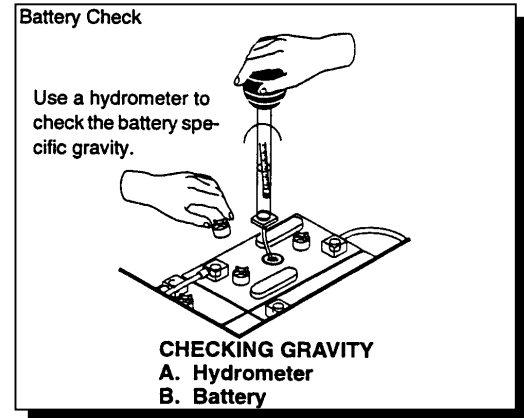

To find the correct specific gravity reading when the temperature of the battery electrolyte is other than 80° F (27° C).

Add (+) to the specific gravity reading

SPECIFIC GRAVITY	BATTERY CONDITION
1.265	100% CHARGED
1.225	75% CHARGED
1.190	50% CHARGED
1.155	25% CHARGED
1.120	DISCHARGED

0.004 (4 points), for each 10° F (6° C) above 80° F (27° C) Subtract (-) from the specific gravity reading 0.004 (4 points), for each 10° F (6° C) below 80° F (27° C).

MAINTENANCE

TO CHARGE BATTERIES

When servicing machine, avoid contact with acid.

⚠ WARNING

Batteries emit hydrogen gas. Explosion or fire can result. Keep sparks and

⚠ WARNING

open flame away. Keep covers open when charging.

⚠ WARNING

Wear eye protection and protective clothing when working with batteries.

⚠ WARNING

Charge batteries in a well ventilated area.

1. Stop the machine in a clean, well ventilated area next to the charger.
2. Turn the machine off and set parking brake.

FOR SAFETY: Before leaving or servicing machine, stop on level surface, apply parking brake, turn off machine and remove key.

3. Raise the seat and raise the support arm to lock in place.

⚠ WARNING

Batteries emit hydrogen gas. Explosion or fire can result. Keep sparks and open flame away. Keep covers open when charging.

4. Check the electrolyte level in each battery cell. Before charging, add just enough water to cover up the plates. After recharging has completed, add just enough water to bring up the level to the indicator ring. If water level is too high before charging, normal expansion of the electrolytes may cause and overflow, resulting in loss of battery acid balance and damage to the machine.
5. Replace battery caps, and leave them in place while charging.
6. Unplug the battery connector from the machine. Unplug the battery charger from power outlet.

FOR SAFETY: When charging, connect the charger to the batteries before connecting the charger to the AC wall outlet. Never connect the charger to the AC first. Hazardous sparks may result.

7. Use a 36 volt DC charger which will automatically shut off when the batteries are fully charged to charge the six battery pack.

8. Plug the charger into the battery connector. Plug battery charger into power outlet. The charger gauge should indicate that the batteries are charging. If the charger does not automatically start up, verify that charger is plugged into batteries.
9. When the batteries are fully charged, disconnect the charger from the batteries.
10. Connect the batteries to the machine connector.
11. Check the electrolyte level. It should be up to the indicator ring. If necessary, add distilled water.
12. Lower the seat.

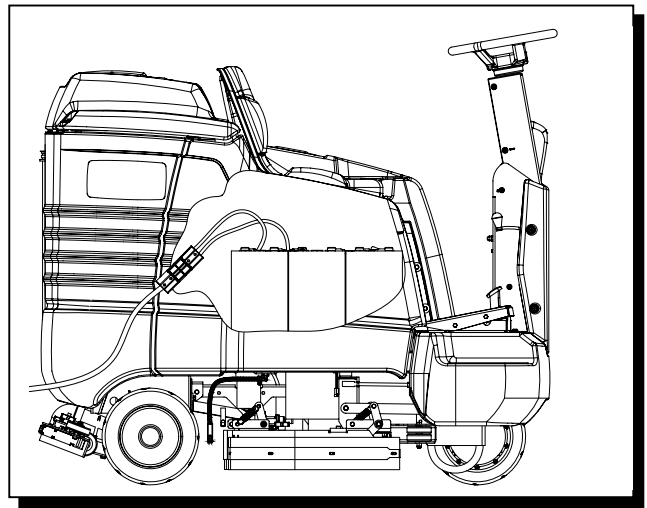

LOW BATTERY SHUT-DOWN

The electronic system is equipped with battery voltage sensors. When the batteries are exhausted to a preset level, the scrubbing system will shut down to protect the batteries from damage, and the battery lockout icon will appear on the display.



TO REMOVE BATTERIES

1. Stop the machine in a clean area next to the charger.
2. Turn off machine and set parking brake.

FOR SAFETY: Before leaving or servicing machine, stop on level surface, apply parking brake, turn off machine and remove key.

3. Raise the seat plate.
4. Remove side cover.
5. Disconnect battery pack from the machine.
6. Use the proper size open end wrench to disconnect main ground wire first and secure cable terminal away from batteries.
7. Disconnect main positive lead and secure cable terminal away from battery/batteries.
8. Loosen both terminals on each jumper cable and remove one at a time.
9. Prepare a suitable battery site to place batteries.
10. Attach suitable battery lifting device and lift batteries from the machine.

⚠ CAUTION

Batteries are a potential environmental hazard. Consult your battery supplier for safe disposal methods.

TO REPLACE BATTERIES

1. Refer to diagram. Place batteries in battery compartment.
2. Connect all jumper cables positive to negative to the six batteries.
3. Connect the positive cable to battery in the position shown.
4. Connect negative cable to battery in the position shown.

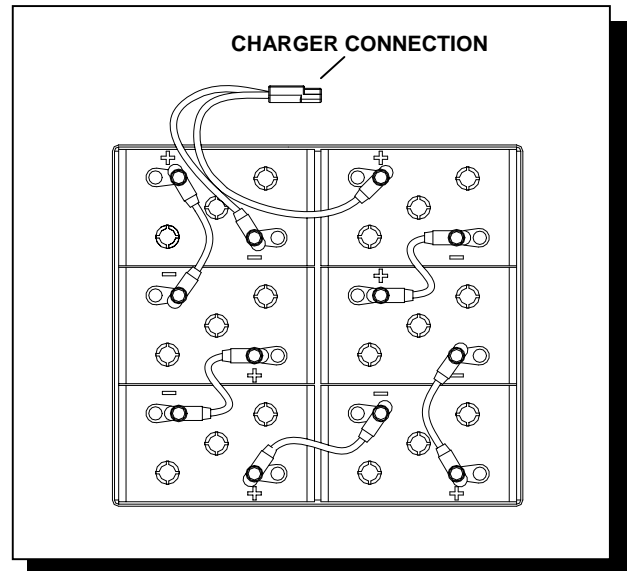

2. BATTERY TRAY DRAIN HOSE

This hose is used to drain any excess water that collects at the bottom of the battery tray. The hose is located underneath the machine. Reference battery section.

⚠ CAUTION

When servicing machine, avoid contact with battery acid.

⚠ WARNING

Wear eye protection and protective clothing when working with batteries

MAINTENANCE

3. SQUEEGEE ADJUSTMENT

Adjusting the squeegee is a two-part process. First, the squeegee tool must have correct pitch in order for the squeegee blade to have the same deflection at each tip as well as the center. The pitch adjustment is facilitated by the use of a spirit level mounted on the squeegee tool. The second adjustment is the amount of deflection or down pressure on the squeegee.

TO ADJUST SQUEEGEE PITCH

1. Choose a smooth, level surface. Turn on the key switch, release the machine parking brake, lower the squeegee and drive forward at least 2 feet (60 cm).
2. With the squeegee down, stop the machine and set the parking brake. Do not allow the machine to roll back.

FOR SAFETY: Before leaving or servicing machine; stop on level surface, turn off machine and remove key.

3. Determine the differences, if any, in deflection of the squeegee blade between each end and the middle. Proper adjustment is obtained when deflection is equal all the way across tool. This should correspond to the bubble being in the middle position of the spirit level.
4. To decrease the deflection of the squeegee blade at the ends, turn knob on squeegee trailing arm clockwise. To increase the deflection at the ends of the squeegee assembly, turn knob counter clockwise.
5. Again check the deflection of the squeegee blades. Repeat steps 1 through 4 until the deflection is equal across the entire rear squeegee blade.

TO ADJUST SQUEEGEE DEFLECTION

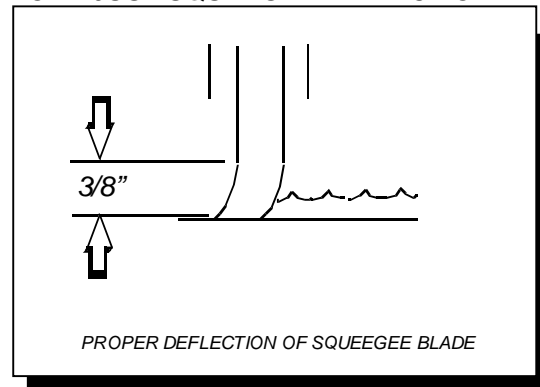

1. Choose a smooth, level surface. Lower the squeegee and drive forward at least 2 feet.
2. With the squeegee down, stop the machine and set the parking brake. Do not allow the machine to roll back.

FOR SAFETY: Before leaving or servicing machine; stop on level surface, turn off machine and remove key.

3. Observe the amount of squeegee deflection. It should deflect 3/8in (9.5 mm) across the entire width of the squeegee.
4. To increase the squeegee deflection, turn the knobs over the squeegee floor wheels counterclockwise. To decrease the squeegee deflection turn the knob over the squeegee floor wheels clockwise. Each knob can be adjusted separately to insure that the blade curls evenly from end to end.
5. Turn on the key switch, release the parking brake. Raise, then lower squeegee assembly. Drive forward at least 2 feet.
6. Repeat steps 2 through 5 until deflection of 3/8 in (9.5 mm) is reached.

TO REPLACE OR ROTATE REAR SQUEEGEE BLADES

1. With the squeegee in the up position, turn off the key switch and set the parking brake.

FOR SAFETY: Before leaving or servicing machine; stop on level surface, turn off machine and remove key.

2. Unlock and pull open latch on rear of squeegee tool.
3. Remove blade retainer straps from squeegee tool.
4. Remove squeegee blade from locating pins on squeegee tool and rotate to new position or replace as required.
5. Install blade on locating pins of squeegee tool.
6. Install squeegee retainer straps.
7. Fasten and lock latch. Latch is adjustable. Adjust latch only tight enough to take up slack in retaining strap.

NOTE: Changing of squeegee blades does not always necessitate a readjustment. Refer to section on adjusting squeegee.

TO REMOVE SQUEEGEE ASSEMBLY

1. With the squeegee in the up position, turn off the key switch and set the parking brake.

FOR SAFETY: Before leaving or servicing machine; stop on level surface, turn off machine and remove key.

2. Disconnect vacuum hose and loosen the two squeegee retaining knobs.
3. Pull squeegee assembly rearward from the lifting carrier.
4. With squeegee assembly on bench inspect or repair as necessary.
5. To reinstall, align squeegee assembly to lift carrier. Push forward until squeegee is fully engaged.
6. Tighten knobs.
7. Attach vacuum hose.

TO REPLACE OR ROTATE FRONT SQUEEGEE BLADES

1. With squeegee assembly on bench, loosen retaining bolt and locking nut on the left side of the retaining strap.
2. Remove front retainer strap.
3. Remove squeegee blade from locating pins on squeegee tool and rotate to new position or replace as required.
4. Install blade on locating pins of squeegee tool.
5. Replace front retainer strap.
6. Secure strap by tightening retaining bolt and locking nut on retainer strap.

NOTE: Changing of squeegee blades does not always necessitate a readjustment. Refer to section on adjusting squeegee.

MAINTENANCE

4. SIDE SQUEEGEE ADJUSTMENT

TO REPLACE OR ROTATE SIDE SQUEEGEE BLADES (28 in. & 32 in.)

1. Loosen the locking knob and pivot the side squeegee out as if to expose the brush.
2. Loosen and remove the three nuts and bolts securing squeegee blades.
3. Remove the retaining strap and squeegee blade and rotate or replace squeegee blade.
4. Install blade and retaining strap on locating pin and reinstall three bolts and nuts.
5. Tighten nuts. Do not over tighten nuts as this will damage the retaining strap and deform the squeegee blade.
6. Pivot the side squeegee back into place and tighten the locking knob.

ADJUSTING THE SIDE SQUEEGEE DEFLECTION

Side squeegee should deflect approximately 3/8 in. when in use. If the blade is under curled it will skip low spots and leave puddles. If the blade is over curled or worn it will smear water and leave stripes and streaks.

1. Choose a smooth level surface. Lower the scrub deck to the floor and drive forward slowly while observing the curl and squeegee performance.
2. To increase the curl, turn the deflection adjustment knob counter clockwise.
3. To decrease the curl, turn the deflection adjustment knob clockwise.

TO REPLACE OR ROTATE SIDE SQUEEGEE BLADES (36 in.)

Left Side Squeegee

1. Loosen the locking knob and unscrew it until it is near the top of the stud. Remove the side squeegee assembly.
2. Loosen and remove the three nuts and bolts securing the squeegee blade.
3. Remove the retaining strap and squeegee blade and rotate or replace the blade.
4. Install blade and retaining strap on locating pin and reinstall three nuts and bolts.
5. Tighten nuts. Do not over tighten nuts as this will damage the retaining strap and deform the squeegee blade.
6. Replace the side squeegee and tighten the knob.

Right Side Squeegee and Secondary Side Squeegee Blade

1. Loosen the locking knob and unscrew it until it is near the top of the stud. Remove the side squeegee assembly.
2. Loosen and remove the three nuts and bolts securing the secondary squeegee blade.
3. Remove the retaining strap and squeegee blade and rotate or replace the blade.
4. Reinstall the blade, retaining strap and fasteners.
5. Do not over tighten nuts as this will damage the retaining strap and deform the squeegee blade.
6. To access the right side squeegee blade, the secondary blade bracket must be removed. Remove two bolts holding the secondary blade bracket and set the bracket aside.
7. Loosen and remove the three nuts and bolts securing the side squeegee blade.
8. Remove the retaining strap and squeegee blade and rotate or replace the blade.
9. Install blade and retaining strap on locating pin and reinstall three nuts and bolts.
10. Tighten nuts. Do not over tighten nuts as this will damage the retaining strap and deform the squeegee blade.
11. Replace the secondary squeegee blade bracket.
12. Replace the side squeegee and tighten the knob.

ADJUSTING (36 in.)

The adjusting procedure is the same for all side squeegees.

The right side squeegee is provided with two adjusting knobs to allow greater control of the curl from front to rear.

5. SCRUB BRUSHES

There are five different types of brushes available to cover applications from cleaning heavily soiled floors to polishing. A pad driver is also available to take advantage of the many cleaning pads on the market and further add to the flexibility of the machine. Please refer to the following to assist in selecting the proper brush or pad for the work at hand.

UNCOATED FLOORS

Aggressive Grit is a nylon fiber impregnated with silicone carbide grit. It grinds away stain, soil, and removes surface material.

Mild Grit is a less aggressive silicone carbide grit suitable for cleaning medium soil conditions. Advantages are faster ground speed than nylon bristles on light solid applications.

Nylon is a general-purpose scrub brush with stiff bristles.

Polypropylene works well for maintaining concrete, wood and tile floors.

FINISHED FLOORS

Nylon bristles are used in a variety of applications on coated or uncoated surfaces.

Polypropylene bristles work on a variety of floor surfaces. Does not soften in water

White Pads (Polishing) are used for dry polishing to achieve a high-gloss appearance, or surface washing on highly polished or burnished floors.

Red Pads (Buffing) are used for light-duty scrubbing. When used with a mild detergent they will provide surface cleaning without removing the finish.

Blue Pads (Scrubbing) are used for heavy-duty scrubbing and light stripping. The blue pads remove less finish than brown stripping pads, yet will remove black marks, stains and dirt.

Brown Pads (Stripping) are used for easy and complete removal of old floor waxes/finishes. They will quickly remove ground in dirt, black heel marks, and spills. When used with the proper stripper, this pad leaves the floor clean and ready for finishing.

REPLACING OR INSTALLING SCRUB BRUSHES

The scrub brushes should be checked before each days work for wire, string, wear, or damage. The scrub brushes should be replaced if brush bristles are missing or if shorter than 5/8 inch.

NOTE: For uniform scrubbing, scrub brushes must be replaced as a set.

28 in. & 32 in.

1. With the scrub deck up, turn off the machine and set the parking brake.
2. Loosen side squeegee locking knob, and pivot side squeegee away from scrub deck.
3. Locate release lever on top of brush or pad driver. With finger rotate release lever against spring pressure counter clockwise. Brush/pad driver will release and drop down.
4. To reinstall, center the cut out of the release lever plate on brush/pad driver to be installed under the brush drive hub.
5. Raise brush/pad drive up until assembly contacts brush hub. Rotate slightly until drive engages release lever plate.
6. While holding upward pressure, rotate brush/pad driver assembly clockwise. When fully engaged, release lever plate will rotate under spring pressure to lock assembly.

NOTE: Check that release plate is completely closed and pad/brush is securely attached. Damage to driver or brush could occur.

7. Repeat the procedure for the opposite side of the machine.

36 in. (Right Side and Center)

1. With scrub deck up and retracted, turn off the machine and set the parking brake.
2. Loosen side squeegee locking knob and unscrew it until it is near the top of the stud. Remove the side squeegee assembly.

NOTE: For the best access to the center brush, remove the right brush.

MAINTENANCE

3. Locate release lever on top of brush or pad driver. With finger rotate release lever against spring pressure counter clockwise. Brush/pad driver will release and drop down.
4. To reinstall, center the cut out of the release lever plate on brush/pad driver to be installed under the brush drive hub.
5. Raise brush/pad driver up until assembly contacts brush hub. Rotate slightly until driver engages release lever plate.
6. While holding upward pressure, rotate brush/pad driver assembly clockwise. When fully engaged, release lever plate will rotate under spring pressure to lock assembly.

NOTE: Check that release plate is completely closed and pad/brush is securely attached. Damage to driver or brush could occur.

7. Repeat the procedure for the opposite side of the machine.
8. The center brush should be changed from the right side.
9. Reinstall the side squeegees.

6. VACUUM FILTER

The vacuum filter is located inside the recovery tank. The vacuum filter prevents debris from entering the vacuum motor. Daily remove and clean filter of any debris for maximum airflow.

7. FLOAT SWITCH

The float switch is located inside the recovery tank. The purpose of the float switch is to notify the user that the recovery tank is full. When the float switch is activated, the scrub brush motors and solution flow will stop, the scrub deck will raise, the squeegee will rise after 60 seconds, and the vacuum motor will turn off 10 seconds later.



Icon appears on information screen 1 when float switch is activated.

8. SOLUTION STRAINER

The solution strainer is located behind the right rear wheel of the Glide. The solution strainer protects the solenoid valve from debris. If there is little or no solution flow to the ground, check the strainer for debris. Drain the solution tank and clean the solution strainer.

To remove the strainer, turn the bottom part of the strainer counterclockwise until the bottom is separated. Clean out the debris from the wire mesh

and re-assemble. Make sure the O-ring gasket is in place when re-assembled.

9. BRAKE

(Refer to Brake Group in the Parts section of the manual).

The brake pedal and parking brake operate the self-centering front wheel disc brake. The disc and caliper should be inspected every 200 hours of operation for cracks and disc wear. The brake should be adjusted so that the disc pads are as close to the disc as possible, without causing brakes to drag.

BRAKE ADJUSTMENT

FOR SAFETY: Before leaving or servicing machine, stop on a level surface, turn off machine and remove key.

1. Disconnect batteries from machine.
2. Turn the steering wheel fully to the left.
3. Locate the brake adjustment screw on the brake caliper.
4. Loosen the lock nut.
5. Turn adjustment screw in until finger tight, then back off 1/8 turn.
6. Hold adjustment screw and tighten lock nut.

10. STEERING CHAIN TENSIONER

(Refer to Steering Group in parts section of manual).

The steering chain transfers power from the steering shaft to the drive wheel, controlling steering response. Check the chain condition and tension every 200 hours of operation. Proper chain tension is important to maintain steering response. The chain should deflect 1/16 in. Use a light spray lube if needed.

STEERING CHAIN TENSIONER ADJUSTMENT

1. Locate chain tensioner bolts.
2. To increase tension, tighten lock nuts retaining chain tension plate.
3. To decrease tension, loosen lock nuts retaining chain tension plate.

11. VACUUM MOTOR

(Refer to the Vacuum Group in the parts section of manual)

⚠ WARNING

Do not use a pressure washer to clean around the vacuum motors. Use tap pressure only. Care must be taken so that water is not directed into vacuum motor air intakes.

CHANGING VACUUM MOTOR

1. Remove side cover.
2. Disconnect electrical connector to the vacuum motor.
3. Loosen clamp and disconnect hose from vacuum intake.
4. Loosen clamp and disconnect vacuum muffler from vacuum outlet.
5. Remove vacuum motor mounting bracket bolts, which are located under frame.
6. Remove vacuum motor from mounting bracket assembly.
7. Reverse steps to install.

Vacuum Motor Carbon Brushes Replacement (Windsor)

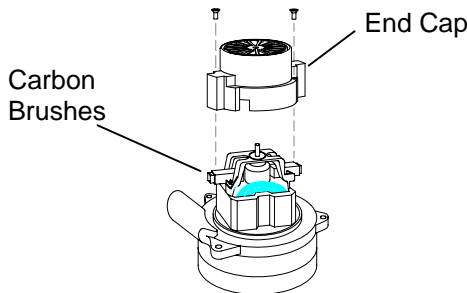

If armature commutator is grooved, extremely pitted or not concentric, the motor will need to be replaced or sent to a qualified service center.

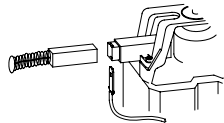

Important:

These brushes wear quicker as the length shortens due to increased heat. Spring inside brush housing will damage motor if brushes are allowed to wear away completely.

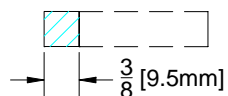

Periodically check the length of the carbon brushes. Replace both carbon brushes when either is less than 3/8" (9.5mm) long.

Vacuum Motor Carbon Brushes Replacement (Ametek)

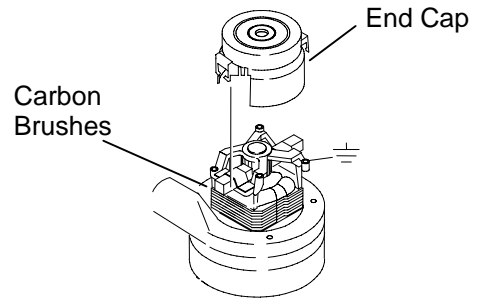

If armature commutator is grooved, extremely pitted or not concentric, the motor will need to be replaced or sent to a qualified service center.

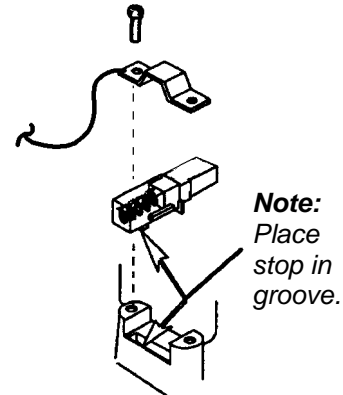

Important:

These brushes wear quicker as the length shortens due to increased heat. Spring inside brush housing will damage motor if brushes are allowed to wear away completely.

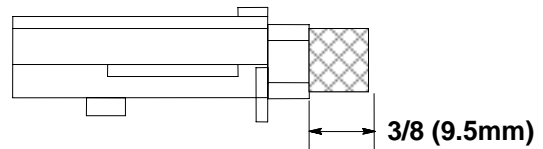

Periodically check the length of the carbon brushes. Replace both carbon brushes when either is less than 3/8" (9.5mm) long.

MAINTENANCE

12. BRUSH MOTOR

(Refer to Brush Motor Group in parts section of manual).

WARNING

Do not use a pressure washer to clean around the brush motors. Use tap pressure only.

CHANGING BRUSH MOTORS

1. With the scrub deck in the stored position, disconnect brush motor wiring connector from harness.
2. Loosen side squeegee locking knob, and pivot side squeegee away from scrub deck to access and remove scrub brushes or pad drivers.
3. Remove retaining bolt, lock washer, flat washer and star drive from brush motor shaft.
4. Remove 4 brush motor mounting bolts located under scrub deck.
5. Remove brush motor. If needed, lower scrub deck for more clearance.
6. Reverse steps to install.

BRUSH MOTOR CARBON BRUSH REPLACEMENT

1. Scribe alignment marks on motor barrel to motor cap and motor barrel to motor frame.
2. Remove end cap from motor.
NOTE: Motors contain two wave washers in cap. Do not lose these.
3. Release brush from spring tension. Remove screw connecting brush wire lead to brush holder. Clean brush holder to insure free movement.
4. Install new brush and reinstall connecting screw and lead.
5. When all new brushes are installed. Place all in retracted position, held into brush holder by spring tension.
6. Carefully place end cap onto bearing on motor shaft.
NOTE: On motors use care to assure wave washer alignment.
7. With end cap in partially installed position, release all brushes to contact position with motor commutator.
NOTE: Failure to insure all brushes are released will result in motor failure.
8. Reset end cap and realign with scribe marks on motor barrel.
9. Maintain alignment between motor barrel base and cap, and between motor barrel and motor frame. Reinstall the two attach bolts from cap into base

13. TRACTION MOTOR

⚠ WARNING Do not use a pressure washer to clean around the brush motors. Use tap pressure only.

TRACTION MOTOR CARBON BRUSH REPLACEMENT

FOR SAFETY: Before leaving or servicing machine, stop on a level surface, turn off machine and remove key.

1. Disconnect batteries from machine.
2. Turn the steering wheel fully to the right.
3. Disconnect the electrical connection to the traction motor (keeping note of which wire is positive and negative). Use a wrench to hold locking nuts while loosening connector nut to prevent threaded stud from turning.
4. Scribe alignment mark on motor barrel to motor cap.
5. Remove end cap from motor.
NOTE: Motors contain two wave washers in cap. Do not lose these.
6. Release brush from spring tension. Remove screw connecting brush wire lead to brush holder. Clean brush holder to insure free movement.
7. Install new brush and reinstall connecting screw and lead.
8. When all new brushes are installed. Place all in retracted position, held into brush holder by spring tension.
9. Carefully place end cap onto bearing on motor shaft.
NOTE: On motors use care to assure wave washer alignment.
10. With cap end in partially installed position, release all brushes to contact position with motor commutator.
NOTE: Failure to insure all brushes are released will result in motor failure).
11. Maintain alignment between motor barrel base and cap. Reinstall the two attach bolts from cap into base.

14. FUSE

The fuse is a one-time circuit protection device designed to stop the flow of electrical current in the event of an electrical overload. If fuse is blown, it must be replaced.

The fuse is located inside the battery compartment.

15. CIRCUIT BREAKERS

Interrupt the flow of power in the event of an electrical overload. When a circuit breaker is tripped, reset it by pressing the exposed button. If a circuit breaker continues to trip, the cause of the electrical overload should be found and corrected.

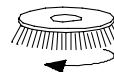

25 Amp. Protects the left scrub brush motor.

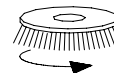

25 Amp. Protects the right scrub brush motor. (28 in & 32 in)
Protects the center brush motor (36 in)

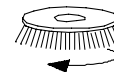

25 Amp. Protects the right scrub brush motor. (36 in)

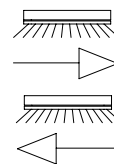

2 Amp. Protects the scrub deck shift actuator (36 in)

MAINTENANCE

16. SQUEEGEE ACTUATOR REMOVAL/REPLACEMENT

FOR SAFETY: Before leaving or servicing machine, stop on a level surface, turn off machine and set parking brake.

1. Remove squeegee to gain access to lift system.
2. Lower squeegee lift linkage, if possible, by pressing bottom of vacuum/squeegee switch and turn key to the off position.
3. Remove lower clevis pin by removing rue ring and washer from clevis pin, then pull pin out from squeegee lift bracket and actuator.
4. Remove upper clevis pin (ball detent type) by pulling on it's ring (located on left side), then pull it out from the frame and actuator. Pull actuator down to remove from the machine, make sure not to allow actuator barrel position to move.
5. Disconnect actuator from wire harness.
6. Reverse steps to install.

SQUEEGEE ACTUATOR ADJUSTMENT

The actuator will need to be adjusted when replaced. The actuator needs to be set such that it does not bind against itself in the raised/retracted position, and does not bind against the axle in the lowered/extended position.

To adjust the actuator:

1. While holding actuator barrel to prevent it from spinning, apply power to the actuator such that it is fully extended. Positive power to white wire, and negative/ground to black. Limit switch within actuator will stop it.
2. Turn barrel out one or more full turns to assure that when it is retracted it will not bind against itself.
3. While holding actuator barrel to prevent it from spinning, apply power to the actuator such that it is fully retracted. Positive power to black wire, and negative/ground to white wire. Limit switch within actuator will stop it.
4. With actuator fully retracted, turn barrel in until it touches the base of the threaded shaft.
5. At the bottomed out position, turn the barrel out **1 full turn**, then enough to allow connection to lift linkage.
6. Connect actuator to lift linkage and check that in the raised/retracted position it does not bind against itself, and in the lowered/extended position does not bind against the axle
7. If further adjustment is needed, disconnect the actuator from squeegee lift linkage and turn the barrel one half-turn at a time in to eliminate binding against axle, or out to eliminate binding against itself.

17. SCRUB DECK ACTUATOR REMOVAL/REPLACEMENT

FOR SAFETY: Before leaving or servicing machine, stop on a level surface, turn off machine and set parking brake.

28 IN. & 32 IN.

1. Lower scrub deck, if possible, by pressing one-touch switch and turn key to off position.
2. Remove lower clevis pin by removing rue ring from clevis pin, then pull pin out from scrub deck lift bracket and actuator.
3. Remove upper clevis pin (ball detent type) by pulling on it's ring (located on left side), then pull it out from the frame and actuator. Remove from the machine, make sure not to allow actuator barrel position to move.
4. Disconnect actuator from wire harness.
5. Reverse steps to install.

36 IN.

1. Lower scrub deck, if possible, by pressing one touch switch and turn key to off position.
2. Disassemble actuator from lift brackets on deck by loosening, but not removing, nuts.
3. Remove upper clevis pin by removing rue ring from clevis pin, then pull pin out from frame and actuator.
4. Disconnect actuator from wire harness.
5. Reverse steps to install.

SCRUB DECK ACTUATOR ADJUSTMENT

The actuator will need to be adjusted when replaced. The actuator needs to be set such that the scrub deck stops barely touch the rubber bumpers on the frame in the raised/retracted position.

To adjust the actuator:

1. While holding actuator barrel to prevent it from spinning, apply power to the actuator such that it is fully extended. Positive power to white wire, and negative/ground to black. Limit switch within actuator will stop it.
2. Turn barrel out one or more full turns to assure that when it is retracted it will not bind against itself.
3. While holding actuator barrel to prevent it from spinning, apply power to the actuator such that it is fully retracted. Positive power to black wire, and negative/ground to white wire. Limit switch within actuator will stop it.
4. With actuator fully retracted, turn barrel in until it touches the base of the threaded shaft.
- 5a. **For 28 IN. & 32 IN.**
At the bottomed out position, turn the barrel out **3 full turns**, then enough to allow connection to lift linkage.
- 5b. **For 36 IN.**
At the bottomed out position, turn the barrel out just enough to allow connection to lift brackets.
6. Connect actuator to lift linkage and check that in the raised/retracted position the stops on the scrub deck barely touch the rubber bumpers on the frame.

NOTE: If further adjustment is needed, disconnect the actuator from scrub deck lift linkage and turn the barrel one half-turn at a time in to make scrub deck stops closer to bumpers, or out to eliminate excessive pressure against bumpers.

TRANSPORTING MACHINE

TOWING OR PUSHING MACHINE

The machine may be towed for short distances at speeds not to exceed 5 mph. Be careful to avoid damaging machine. Attach towing device at tie down point. The machine may be pushed by hand from the rear.

NOTE: To avoid damage caused by regenerative voltage, disconnect traction motor before towing or pushing machine.

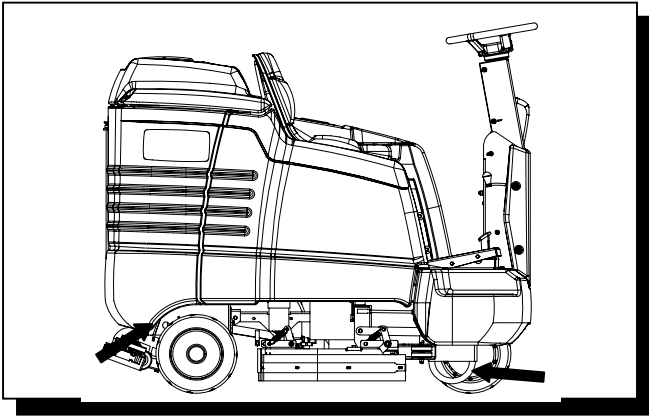

MACHINE TIE-DOWNS

There are two tie points located at the rear, side of the machine frame and two at the front corners. Tie-down devices must be of the proper type and strength. The combined strength of all tie-downs must be strong enough to lift two times the weight of the machine. Tie-downs must be positioned to prevent the machine from moving forward, backward, or either side to side. Use all four corners of the machine with the tie-downs running out opposite directions. Tie-downs must be attached to the transporting vehicle securely.

PREPARATION FOR TRANSPORTING

Remove squeegee tool to eliminate interference with tie-downs.

Scrub head must be in the up position before loading.

NOTE: When transporting the machine on a trailer or in a truck, in addition to using tie-downs, be sure to set the parking brake, and block the tires to prevent the machine from rolling.

MACHINE JACKING

The machine may be jacked up for service or inspection by using the specified jack locations. Always block the tires when jacking up the machine.

FOR SAFETY: Before leaving or servicing machine; Stop on level surface, set parking brake, turn off machine and remove key.

The rear jack points are the frame just behind the rear wheels. Remove the squeegee tool before jacking.

NOTE: See *Squeegee Tool Removal in Maintenance Section*.

The front jacking point is the front bumper.

TO JACK UP MACHINE

1. Empty the recovery and solution tank.
2. Turn the key switch off and set the parking brake.

FOR SAFETY: Before leaving or servicing machine; Stop on level surface, set parking brake, turn off machine and remove key.

3. Block the tires that are not being raised to prevent the machine from rolling.

FOR SAFETY: When servicing machine, block machine tires before raising machine.

4. Using a jack of adequate capacity. Raise the machine using the designated jack points.

FOR SAFETY: When servicing machine, use hoist or jack of adequate capacity, jack machine at designated jack locations only. Block machine with jack stands when raised.

5. When machine is raised, use jack stands at the designated jack locations. Support the front of the machine by placing jack stands or solid wood blocks under the U-shaped stabilizer bars.

FOR SAFETY: Block machine at designated jack locations with jack stands when raised.

6. Slowly lower the machine onto the jack stands.
7. Be sure that the machine is secure.
8. Service or inspect the machine as required.
9. When finished working on the machine, raise the machine off the jack stands.
10. Remove the jack stands.
11. Lower the machine to the floor. Block wheels as they are lowered.
12. Remove wheel block after machine has been completely lowered.

MACHINE STORAGE

If the machine is to be stored for extended periods of time, the following steps must be taken to minimize the chance of corrosion or deposits forming.

1. Drain both solution and recovery tanks. Clean soil and chemical build up from tank. Flush with clean water including the solution delivery system. Leave solution tank lid and recovery tank dome open.
2. Raise the rear squeegee assembly and the scrub deck.
3. Remove brushes and rinse with clean water. Dry thoroughly.
4. Wash squeegee blades with clean water.
5. Park the machine in a cool, dry area.
6. Check the charge level of the batteries monthly. Recharge when batteries drop below 25% charge. If suitable space exists to store batteries from machine, remove from machine.
7. Perform next lubrication interval.



MAINTENANCE

SERVICE SCHEDULE





MAINTENANCE	BEFORE EACH WORK PERIOD	AFTER EACH WORK PERIOD	50 HRS	100 HRS	200 HRS
Check water level of batteries after charging; add distilled water if necessary	*				
Check that recovery tank cover seals tightly	*				
Visually check for damaged or worn tires	*				
Check brushes or pads for proper installation	*				
Check vacuum hose connections	*				
Check that squeegee is securely attached and properly adjusted	*				
Check that side squeegees are properly adjusted	*				
Check for securely attached drain hose, plug and caps	*				
Check brakes and steering for proper operation	*				
Inspect vacuum filter for debris		*			
Clean out solution tank and filter, check flow		*			
Run vacuum motors to dry		*			
Clean brushes or pads and check wear		*			
Clean main and side squeegee blades and check wear		*			
Clean out recovery tank and vacuum filter		*			
Clean and inspect float shutoff		*			
Clean outside of tanks, check for damage		*			
Store with covers off tanks		*			
Charge batteries		*			
Check side squeegee for wear			*		
Clean off top of batteries			*		
Check battery cells with hydrometer			*		
Inspect scrub deck skirts			*		
Clean solution strainers			*		
Check battery connections are tight			*		
Clean battery cases and battery compartment				*	
Check parking brake adjustment					*
Check brakes discs and calipers for damage or wear					*
Clean pivot points on squeegee and scrub deck					*
Check all motors for carbon brush wear					*
Check motor commutators					*
Check steering chain tensioner					*

NOTE: Traction drive, wheels and batteries should be serviced based on traction drive hour meter. The scrub brush hour meter should be used for all other service schedule items.

MACHINE TROUBLESHOOTING

PROBLEM	CAUSE	ERROR CODE	SOLUTION
No power to machine	Battery disconnected		Check connections of all battery cable connections
	Emergency shut-off activated		Reset
	Battery cables corroded		Clean connections
	Main fuse blown		Replace fuse
	Faulty key switch		Replace switch
Little or no propel	Low battery charge		Charge batteries
	Machine turned on with pedal not in neutral position		Allow pedal to return to neutral Restart.
	Wheels spin		Decrease brush pressure
	Controller overheated	7802/7801	Allow cool down period
	Loose motor connection	7800	Check wires and connections from controller to motor
	Loose throttle connections or faulty throttle potentiometer	0814	Check wires and connections from throttle to LCD and potentiometer resistance
	Loose brake switch connection or faulty brake switch		Check connections and switch continuity
	Loose seat switch connection or faulty seat switch		Check connections and switch continuity
Forward speed only	Faulty throttle		Check throttle
Reverse speed only	Faulty throttle		Check throttle
Poor or no water pick-up	Squeegee out of adjustment		Adjust squeegee
	Debris caught on squeegee		Remove debris
	Worn squeegee blades		Rotate or replace squeegee blades
	Vacuum hose clogged		Clear obstruction from hose
	Vacuum hose disconnected from squeegee or recovery tank		Reconnect vacuum hose
	Vacuum hose damaged		Replace hose
	Vacuum motor inlet filter dirty		Clean or replace inlet filter
	Recovery tank not sealed		Replace damaged seals
	Foam filling recovery tank		Empty recovery tank use less or different detergent Use defoamer
Squeegee will not go up/down	Loose connection		Check wires and connections from controller to actuator
	Faulty actuator		Repair/replace actuator

MACHINE TROUBLESHOOTING

PROBLEM	CAUSE	ERROR CODE	SOLUTION
Vacuum motor does not run, or runs slowly	Recovery tank full		Drain recovery tank
	Recovery tank float switch dirty		Clean float switch
	Loose motor connection	7700	Check motor wires and connections
	Worn vacuum motor brushes		Replace brushes, check commutator
Poor scrubbing performance	Debris caught in scrub brushes		Remove debris
	Worn brushes or pads		Replace brushes or pads
	Improper detergent, brush or pad used		Contact equipment or application specialists
	Low scrub brush down pressure		Increase brush pressure
	Low battery charge		Charge batteries
Uneven scrubbing or brush wear on 36 IN.	Deck and/or brush drivers not level.		Adjust parallel links and/or shim brush drivers with washers.
Little or no solution flow to the floor	Solution tank empty		Fill solution tank
	Solution flow turned off or set too low		Turn on or increase flow setting
	Solution strainer plugged		Clean solution strainer
	Solution system plumbing obstructed		Clear obstruction from plumbing
	Solution solenoid valve obstructed or stuck		Clean or replace valve
	Vent hole in solution tank lid obstructed		Clear obstruction from vent hole
	Faulty solenoid valve connection		Check wiring to solution valve
Brush motors do not run, or run slowly	Circuit breaker(s) tripped	7600	Reset circuit breaker(s)
	Low battery charge		Charge battery
	Loose connection	7600	Check motor wires and connection
	Worn brush motor brushes		Replace brushes, check commutator
Scrub deck will not go down/up	Loose connection	9000	Check motor wires and connections
	Faulty actuator	9000	Repair/replace actuator
Scrub deck goes down, then raises	No brushes or pad drivers on machine	9000	Install brushes or pad drivers
Error code not listed is displayed	Controller detects electrical problem		Contact service technician

MACHINE TROUBLESHOOTING - CONTROLLER FAULT CODES

ERROR CODE	PROBLEM	SOLUTION
None	LCD display on, but incomplete	Disconnect batteries and wait 1 minute before re-applying power.
0A01	Power down error	Disconnect batteries and wait 1 minute before re-applying power.
0204	Memory corrupt	Replace controller.
All 080_ codes	Throttle wiring	Check for short or open circuits in throttle wiring.
All 140_ Codes		Check for short circuit between B+ and traction output.
All 310_ Codes	Possible short circuit of motors, auxiliary outputs (headlight, recycle pump, or back-up alarm), wiring or damaged controller	Check for short circuits. If code is present after short circuits are repaired, replace controller.
7500	LCD module communications timeout	Wiring fault on 6-way serial link between controller and display.
7501	LCD module settings corrupt	Disconnect batteries and wait 1 minute before re-applying power.
All 760_ Codes	Brush motor or brush circuit fault	Check for short or open circuits in brush motors or wiring.
All 770_ Codes	Vacuum motor or vacuum circuit fault	Check for short or open circuits in vacuum motor(s) or wiring.
7800	Traction motor open circuit fault	Check for open circuit on propel motor or wiring.
7801	Traction motor overcurrent error	Check for short circuit on propel motor or wiring.
7802	Traction motor in power foldback state	Propel motor current has exceeded current limit for the foldback time.
All 790_ Codes	Emergency stop error	E-stop input active or wiring fault.
9000	Brush current requirement not satisfied	Check that brushes or pads are installed. Check for open circuit in scrub lift actuator, circuit breaker or wiring.

BRAKE – FROM SERIAL NUMBER *(8)

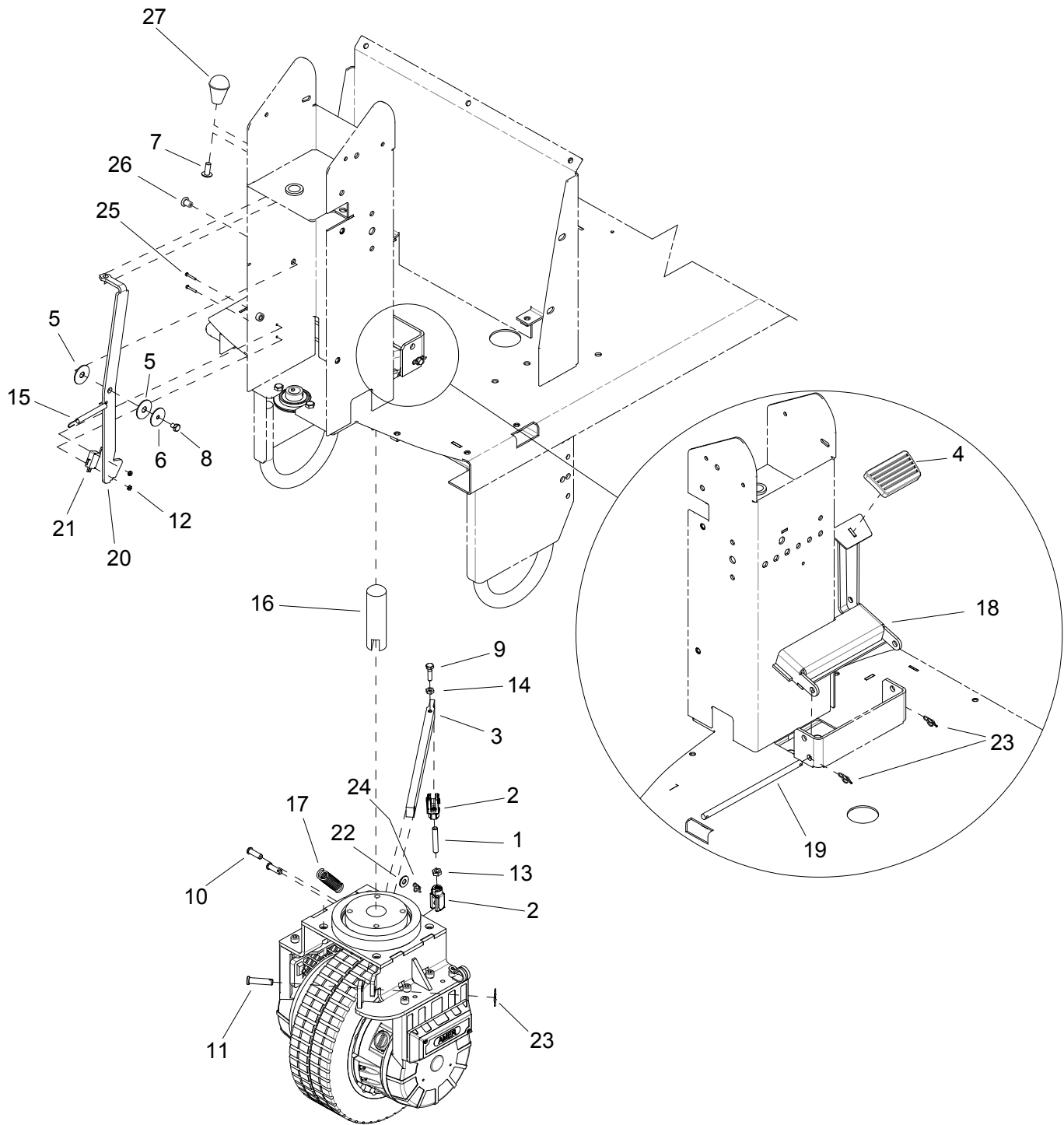

BRAKE – FROM SERIAL NUMBER *(8)

REF	PART NO.	PRV NO.	QTY	DESCRIPTION	SERIAL NO. FROM	NOTES:
1	86358900	-	1	ROD, 5/16-24 ADJUSTMENT		
2	86358860	-	2	ROD END, CLEVIS 5/16-24		
3	86358790	-	1	ARM, BRAKE LEVER		
4	86355600	-	1	PAD, BRAKE PEDAL		
5	86279620	87200	2	WASHER,.4ID X 1.3OD NYLON		
6	86278940	87008	1	WASHER 1/4 ID X 1-1/4 OD PLT		
7	86276890	70752	1	SCREW 5/16-18X3/4 PTHMS SS		
8	86276880	70751	1	SCR, 1/4-20 X 3/8 HHCS SS		
9	86273810	70018	1	SCR, 1/4-20 X 1 HHCS SS		
10	86272550	66485	2	PIN, CLEVIS, 5/16 X 1.00 PLTD		
11	86272400	66232	1	PIN, CLEVIS 3/8 X 1.50 PLTD		
12	86271280	57163	2	NUT, 4-40 W/STAR WASHER		
13	86271130	57127	1	NUT, 5/16-24 HEX JAM PLTD		
14	86270930	57065	1	NUT, 1/4-20 JAM SS		
15	86255560	82855	1	SPRING, .31X .04X 3.0EXT,CS,ZC		
16	86252040	67470	1	ROD, BRAKE PUSH		
17	86226830	73268	1	SPRING EXT .68D X3.00L X.098W		
18	86093360	66363	1	PEDAL, BRAKE, SRS		
19	86078400	66356	1	PIN, CLEVIS 3/8 X 8.26 SS		
20	86077270	51367	1	LEVER, PARKING BRAKE		
21	86028630	72082	1	SWITCH, PT17 SOL LEVER BENT		
22	86010670	87029	2	WASHER 5/16 FLAT SS		
23	86008670	80606	3	COTTER 3/8" RING		
24	86008660	80605	2	COTTER 5/16" RING		
25	86006720	70245	2	SCREW 4-40 X 3/4 PPHMS		
26	86005860	57273	1	NUT 1/4-20 X 12MM HEX BARREL		
27	86004800	48030	1	KNOB, PT20 SOLUTION LEVER		

*SEE SERIAL NUMBER PAGE.

BRAKE – TO SERIAL NUMBER *(8)

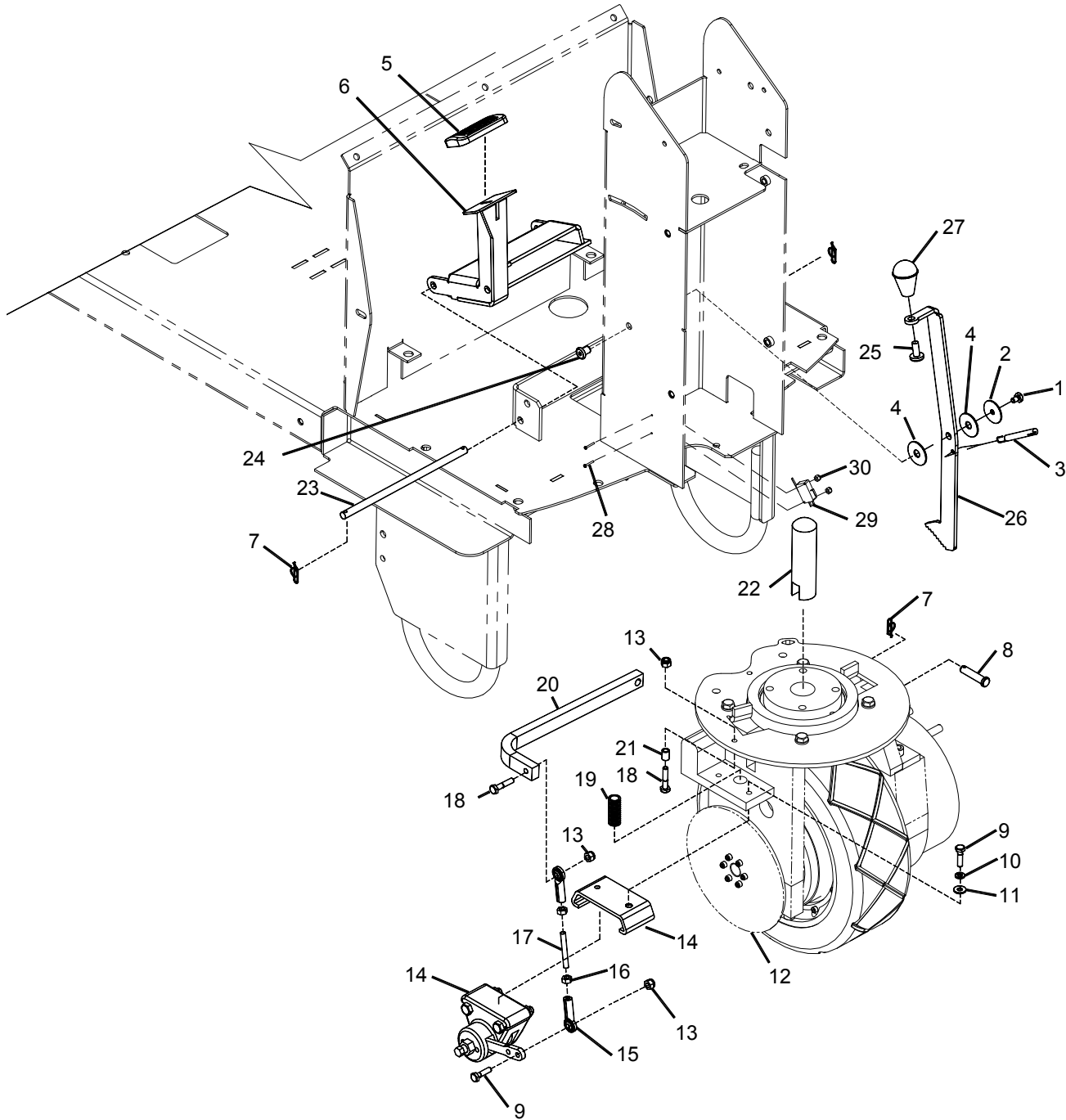

BRAKE – TO SERIAL NUMBER *(8)

REF	PART NO.	PRV NO.	QTY	DESCRIPTION	SERIAL NO. FROM	NOTES:
1	86276880	70751	1	SCR, 1/4-20 X 3/8 HHCS SS		
2	86278940	87008	1	WASHER, 1/4ID X 1-1/4OD PLTD		
3	86255560	82855	1	SPRING, .31 X .04 X 3.0 EXT CS ZC		
4	86279620	87200	2	WASHER, .4ID X 1.3OD NYLON		
5	86355600	-	1	PAD, BRAKE PEDAL		
6	86355540	-	1	PEDAL, BRAKE SRS		
7	86008670	80606	3	COTTER, 3/8" RING		
8	86248980	81438	1	PIN,CLEVIS 3/8" X 1.75 PLTD		
9	86273810	70018	3	SCR, 1/4-20 X 1 HHCS SS		
10	86010780	87162	2	WASHER, 1/4 SPLIT LOCK PLTD		
11	86010630	87013	2	WASHER, 1/4ID X 5/8OD SS		
12	86215650	29251	1	DISK, BRAKE		
13	86005810	57245	3	NUT, 1/4-20 HEX NYLOCK SS		
14	86073850	140466	1	CALIPER, CLOCKWISE BRAKE		
14A	86135470	83050	1	CALIPER ACTUATING PIN		SERVICE ONLY
14B	86134940	83051	1	BACKING PLATE, CALIPER		SERVICE ONLY
14C	86135480	83052	1	PUCK CALIPER		SERVICE ONLY
14D	86010330	83053	1	CALIPER, ANVIL SUB-ASSEMBLY		SERVICE ONLY
15	86251790	67480	2	ROD END, BALL JOINT 1/4-28		
16	86271600	57225	2	NUT, 1/4-28 HEX		
17	86065800	05003	1	ARM, LOWER VAC CONTROL		
18	86273820	70019	2	SCR, 1/4-20 X 1.25 HHCS		
19	86254960	730266	1	SPRING, COMP .67 OD X 1.63 X .08		
20	86066010	140458	1	ARM, BRAKE LEVER		
21	86087430	73206	1	SPACER, 3/8OD X .058W X 1/2L CRS		
22	86252040	67470	1	ROD, BRAKE PUSH		
23	86078400	66356	1	PIN, CLEVIS 0.375 X 8.26L		
24	86005860	57273	1	NUT, 1/4-20 X 12MM HEX BARREL		
25	86276890	70752	1	SCR, 5/16-18 X 3/4 PTHMS SS		
26	86258470	51367	1	LEVER, PARKING BRAKE		
27	86004800	48030	1	KNOB		
28	86006720	70245	2	SCR, 4-40 X 3/4 PPHMS	1000092267	
29	86028630	72082	1	SWITCH, SOL LEVER BENT	1000092267	
30	86271280	57163	2	NUT, 4-40 W/STAR WASHER	1000092267	

*SEE SERIAL NUMBER PAGE.

CIRCUIT BREAKER GROUP

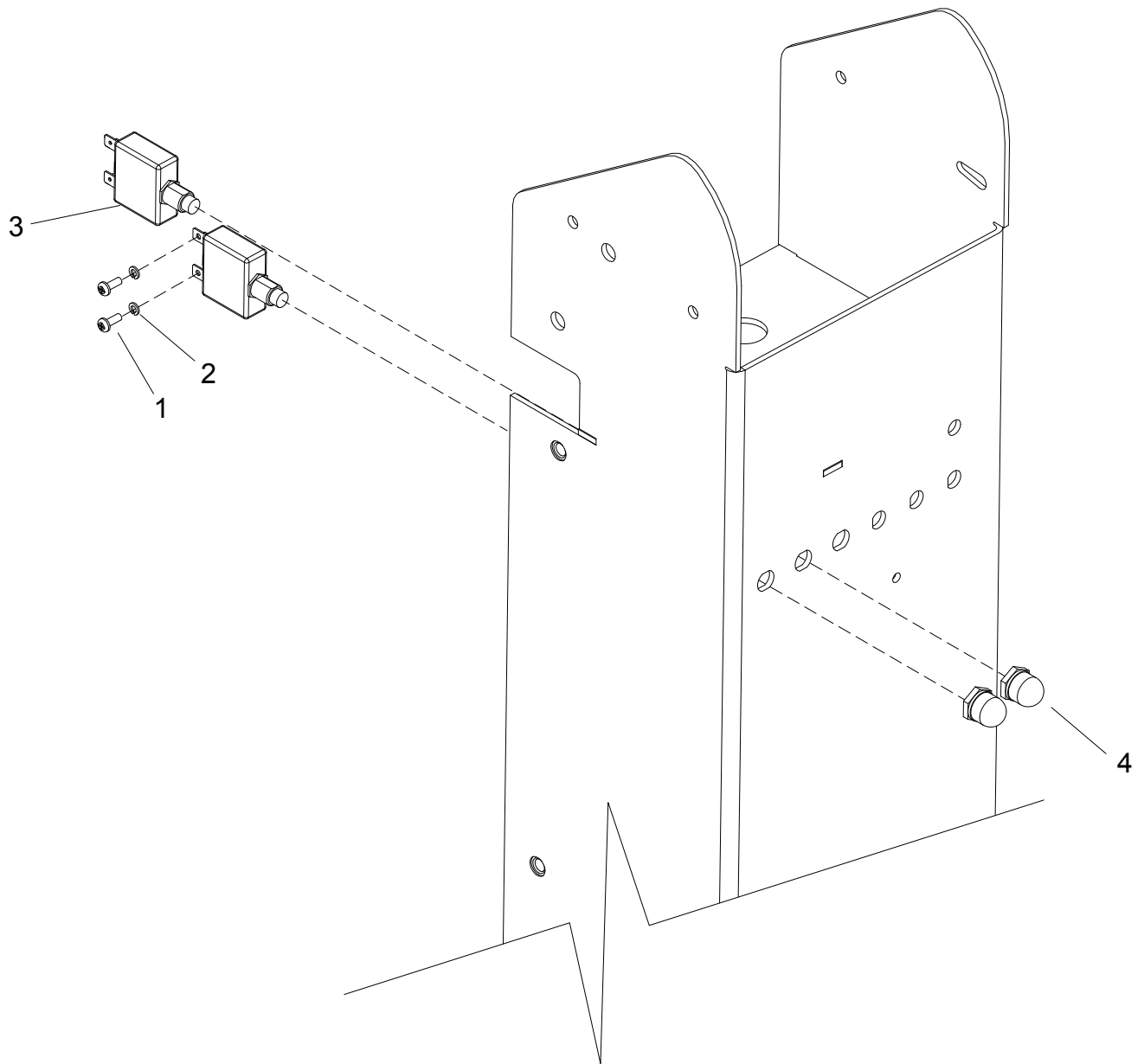

CIRCUIT BREAKER GROUP

REF	PART NO.	PRV NO.	QTY	DESCRIPTION	SERIAL NO. FROM	NOTES:
1	86273990	70067	4/6	SCR, 6-32 X 3/8 PPHMS		4 per 28 & 32/6 per 36
2	86279300	87134	4/6	WASHER, #6 LOCK		4 per 28 & 32/6 per 36
3	86001920	14607	2/3	BREAKER, 25A 50VDC CIRCUIT		2 per 28 & 32/3 per 36
4	86008900	80845	2/3	BOOT, SEAL-PUSH BUTTON 7/16-28		2 per 28 & 32/3 per 36

CONTROL PANEL GROUP

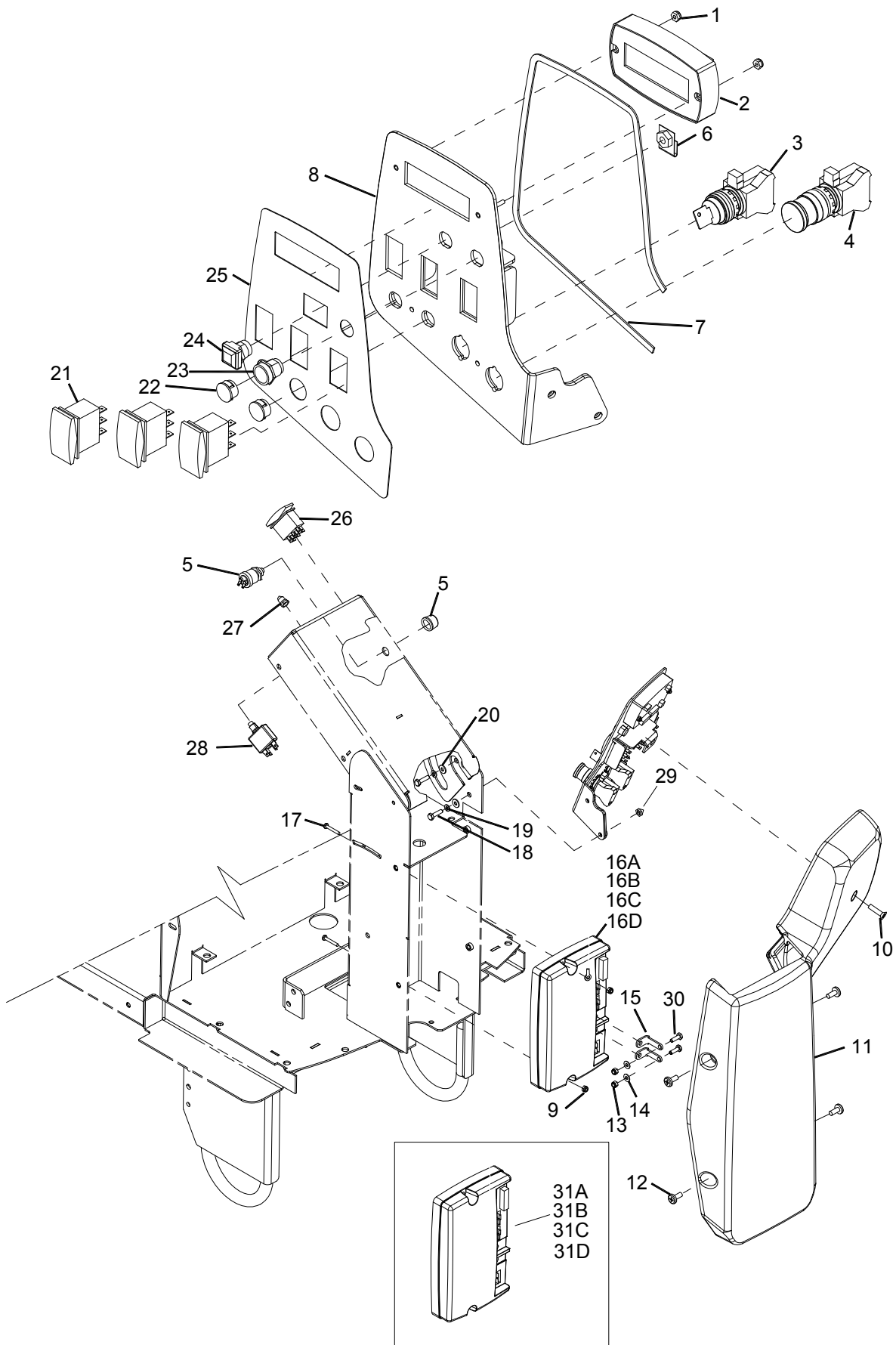

CONTROL PANEL GROUP

REF	PART NO.	PRV NO.	QTY	DESCRIPTION	SERIAL NO. FROM	NOTES:
1	86270920	57049	2	NUT, 6-32 HEX NYLOCK SS		
2	86005550	54183	1	MODULE, LCD		
3A	86007190	72161	1	SWITCH, KEY DPST		
3B	86004860	48073	REF	KEY		SERVICE ONLY
4	86007180	72160	1	SWITCH, EMERGENCY STOP		
5	86257280	81371	1	SWITCH, PUSH BUTTON		
6	86271820	57270	1	NUT, 5/16-18 CAPTIVE "J" PLTD		
7	86238000	36216	1	GASKET, .06T X .25W X 26.5L		
8	86093320	66364	1	PANEL CONTROL		
9	86270990	57090	2	NUT, 10-32 HEX NYLOCK SS		
10	86276900	70753	1	SCR, 5/16-18 X 1-1/4 PFHMS SS		
11	86003230	27936	1	COVER, FRONT SMALL RIDER		
12	86276890	70752	4	SCR, 5/16-18 X 3/4 PTHMS SS		
13	86271910	57295	2	NUT, 5/16-18 FLEXLOCK		
14	86010670	87029	2	WASHER, 5/16 FLAT SS		
15	86068850	140219	2	BRACKET, CABLE ATTACH	*(1)	
16A	86364300	-	1	CONTROLLER, GLIDE 28/32 AMER	*(8)	28 IN & 32 IN
16B	86364310	-	1	CONTROLLER, GLIDE 36 AMER	*(8)	36 IN
16C	86364340	-	1	CONTROLLER, GLIDE 28/32 GEL AMER	*(8)	28 IN & 32 IN WITH SEALED BATTERIES
16D	86364320	-	1	CONTROLLER, GLIDE 36 GEL AMER	*(8)	36 IN WITH SEALED BATTERIES
17	86274410	70195	2	SCR, 10-32 X 1.25 SS		
18	86273810	70018	2	SCR, 1/4-20 X 1 HHCS SS		
19	86010780	87162	2	WASHER, 1/4 SPLIT LOCK		
20	86010630	87013	2	WASHER, 1/4ID X 5/8 OD SS		
21	86007520	730142	3	SWITCH, SPDT 3-POSITION MOM		
22	86250190	66365	2	PLUG, DD .625-.550		
23	86007480	730124	1	SWITCH ASM, SEALED PUSHBUTTON		
24	86007470	730123	1	SWITCH ASM, SEALED PUSH SQ		
25	86243510	500563	REF	LABEL, CONTROL PANEL		
26	86007210	72165	1	SWITCH, DPDT 3-POSITION ROCKER		36 IN. ONLY
27	86002010	14942	1	BOOT, 3/8 CIRCUIT BREAKER		36 IN. ONLY
28	86001450	140541	1	BREAKER, 2A 250VAC, 50VDC		36 IN. ONLY
29	86271940	57299	1	NUT, 1/4-20 ACORN SS		
30	86275760	70540	2	SCR, 5/16-18 X 1 HHCS GR8 PLTD	*(1)	
31A	86002660	270070	1	CONTROLLER, GLIDE 28/32		28 IN & 32 IN
31B	86002670	270071	1	CONTROLLER, GLIDE 36		36 IN
31C	86002680	270072	1	CONTROLLER, GLIDE 28/32 GEL		28 IN & 32 IN WITH SEALED BATTERIES
31D	86027700	270075	1	CONTROLLER, GLIDE 36 GEL		36 IN WITH SEALED BATTERIES

* SEE SERIAL NUMBER PAGE.

** CALL MANUFACTURER FOR SERIAL NUMBER.

DECAL GROUP

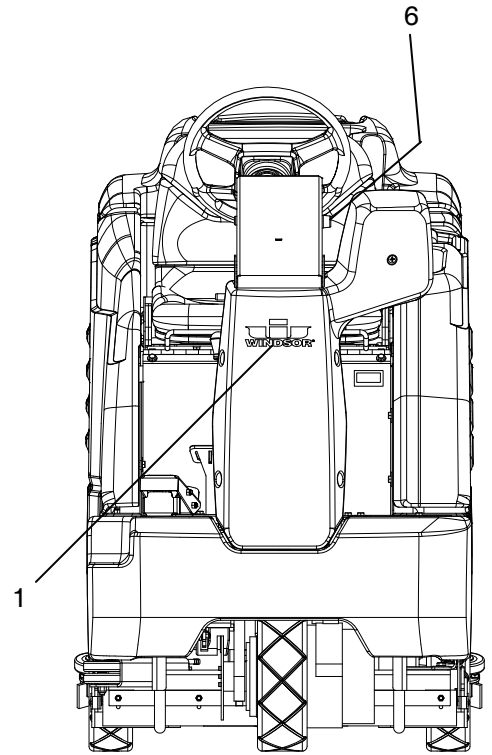
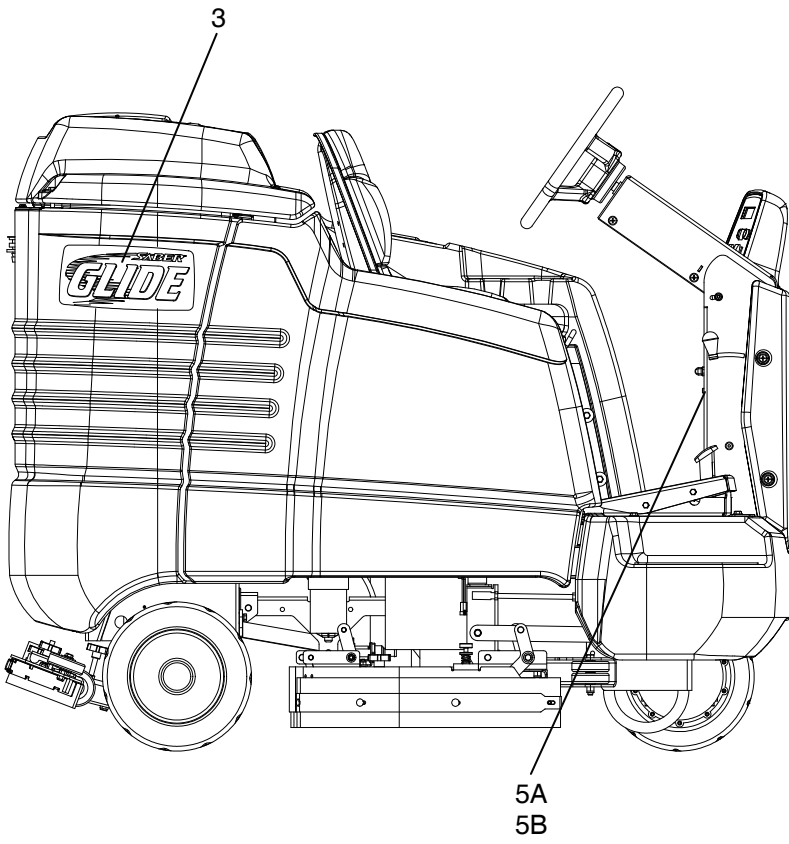
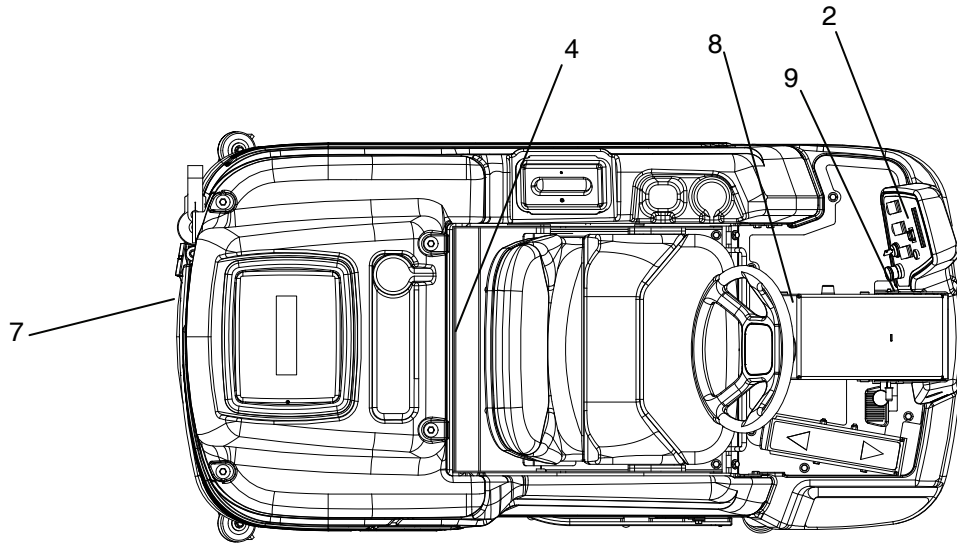

DECAL GROUP

REF	PART NO.	PRV NO.	QTY	DESCRIPTION	SERIAL NO. FROM	NOTES:
1	86004970	50990	1	LABEL, WINDSOR LOGO DOMED		
2	86243510	500563	1	LABEL, CONTROL PANEL		
3	86243570	500574	2	LABEL, GLIDE		
4	86243500	500562	1	LABEL, SRS CHARGING		
5A	86244130	500859	1	LABEL, GLIDE TRIO + CB		28 IN & 32 IN
5B	86244140	500861	1	LABEL, GLIDE 36 TRIO + CB		36 IN.
6	86248210	81349	1	OVERLAY, HORN		
7	86243580	500575	1	LABEL, SOLUTION FILL GLIDE		
8	86243810	500651	1	LABEL, DECK SHIFT 36 INCH		36 IN. ONLY
9	86243820	500662	1	LABEL, COVER SMALL RIDER		

NOTE: SEE "SAFETY LABEL LOCATION" PAGE FOR SAFETY LABEL INFORMATION.

FRONT BUMPER & FLOOR GROUP

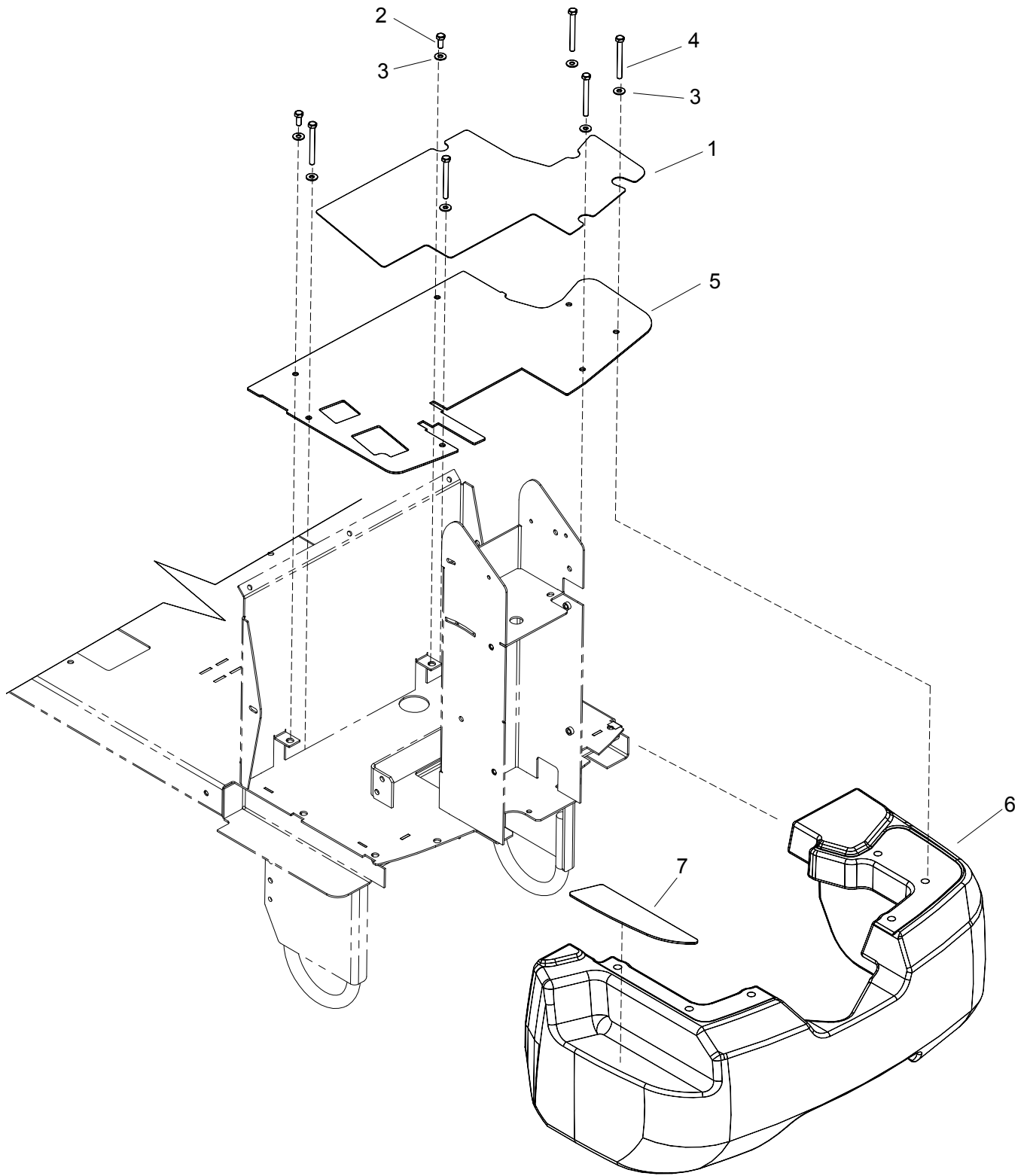

FRONT BUMPER & FLOOR GROUP

REF	PART NO.	PRV NO.	QTY	DESCRIPTION	SERIAL NO. FROM	NOTES:
1	86248350	66360	1	PAD, FLOOR		
2	86276780	70728	2	SCR, 5/16-18 X 3/4 HHCS SS		
3	86010670	87029	7	WASHER, 5/16 FLAT SS		
4	86276910	70754	5	SCR, 5/16-18 X 3 HHCS SS NP		
5	86082320	62952	1	PLATE, FLOOR		
6	86031840	27958	1	COVER, BUMPER DK GRY		
7	86248360	66361	1	PAD, STEP		

FORWARD/REVERSE PEDAL

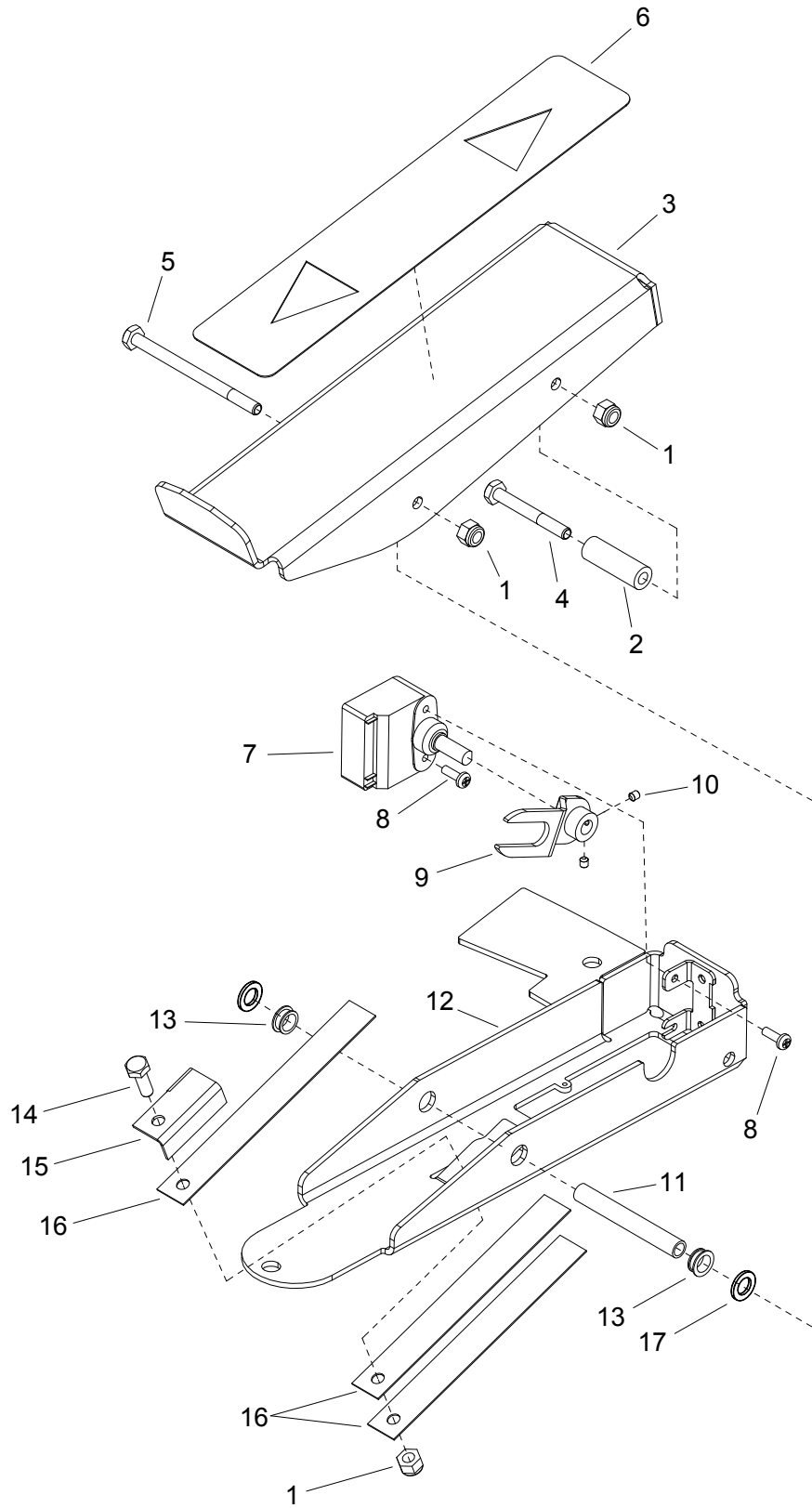

FORWARD/REVERSE PEDAL

REF	PART NO.	PRV NO.	QTY	DESCRIPTION	SERIAL NO. FROM	NOTES:
1	86005810	57245	3	NUT, 1/4-20 HEX NYLOCK SS		
2	86007380	730088	1	SPACER, .50D X .26ID X 1.5L		
3	86078310	66382	1	PEDAL, SMALL RIDER		
4	86273850	70022	1	SCR, 1/4-20 X 2 HHCS		
5	86276940	70758	1	SCR, 1/4-20 X 3.5 HHCS SS NP		
6	86248340	66346	1	PAD, FWD/REV PEDAL		
7	86006330	66343	1	POTENTIMETER, TROTTLE		
8	86276930	70757	2	SCR, 8X1/2 PPH TYPE B SMS SP		
9	86093140	51379	1	LINK, SMALL RIDER THROTTLE		
10	86278060	70759	2	SET SCR, M4 X 4MM NP		
11	86089660	78532	1	TUBE, 3/8 OD X 2.96 L		
12	86091500	140577	1	BASE, SMALL RIDER PEDAL		
13	86228750	09082	2	BEARING, 3/8" FLANGED NYLON		
14	86273780	70015	1	SCR, 1/4-20 X 3/4 HHCS SS NP		
15	86010300	830117	1	BRKT, SPRING ALIGNMENT		
16	86010290	830116	3	SPRING, FLAT		
17	86010680	87030	2	WASHER, 3/8 ID X 3/4 OD NYLON		

SCRUB BRUSH/PAD DRIVER

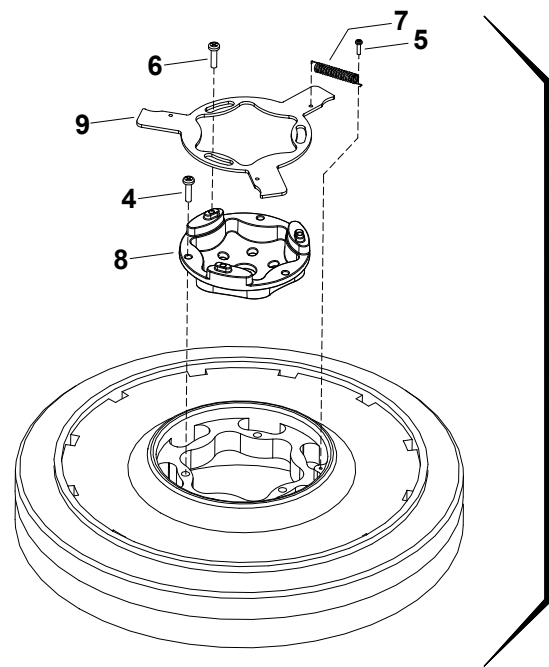
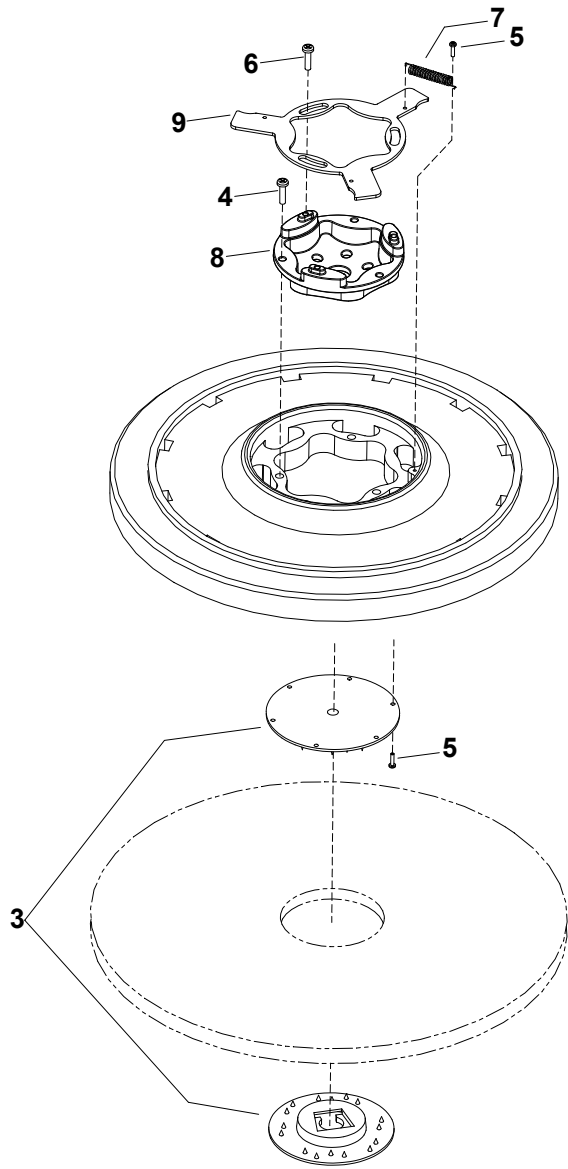

2A
2B
2C
2D

SCRUB BRUSH/PAD DRIVER

28 IN. DISK:

REF	PART NO.	PRV NO.	QTY	DESCRIPTION	SERIAL NO. FROM	NOTES:
1	86000250	02412	2	PAD DRIVER, 14" SD		
2A	86000260	02413	2	BRUSH, 14" POLYPROPYLENE SD		
2B	86000270	02414	2	BRUSH, 14" NYLON SD		
2C	86000280	02416	2	BRUSH, 14" MILD GRIT SD		
2D	86283850	02417	2	BRUSH, 14" SUPER AGG SD		
3	86005070	51284	1	LOCK, PAD CENTER SNAP, TWO STEP		
4	86276590	70695	3	SCR, #12 X 1 PPHSMS SS		
5	86276580	70694	1	SCR, 8-32 X 3/4 PTHMS		
6	86276600	70696	3	SCR, #10 X 3/4 PTHSMS SS		
7	86007910	73817	1	SPRING, EXT .31 D X 2.0 L X .03 W SS		
8	86007280	730011	1	SOCKET, DRIVE BRUSH		
9	86005940	62852	1	PLATE, BRUSH RELEASE		

32 IN. DISK:

REF	PART NO.	PRV NO.	QTY	DESCRIPTION	SERIAL NO. FROM	NOTES:
1	86000290	02418	2	PAD DRIVER, 16" SD		
2A	86000300	02419	2	BRUSH, 16" POLYPROPYLENE SD		
2B	86000310	02420	2	BRUSH, 16" NYLON SD		
2C	86000330	02422	2	BRUSH, 16" MILD GRIT SD		
2D	86000340	02423	2	BRUSH, 16" SUPER AGG SD		
3	86005070	51284	1	LOCK, PAD CENTER SNAP, TWO STEP		
4	86276590	70695	3	SCR, #12 X 1 PPHSMS SS		
5	86276580	70694	1	SCR, 8-32 X 3/4 PTHMS		
6	86276600	70696	3	SCR, #10 X 3/4 PTHSMS SS		
7	86007910	73817	1	SPRING, EXT .31 D X 2.0 L X .03 W SS		
8	86007280	730011	1	SOCKET, DRIVE BRUSH		
9	86005940	62852	1	PLATE, BRUSH RELEASE		

36 IN. DISK:

REF	PART NO.	PRV NO.	QTY	DESCRIPTION	SERIAL NO. FROM	NOTES:
1	86000170	02400	3	PAD DRIVER, 12" SD		
2A	86000180	02401	3	BRUSH, 12" POLYPROPYLENE SD		
2B	86000190	02402	3	BRUSH, 12" NYLON SD		
2C	86000200	02404	3	BRUSH, 12" MILD GRIT SD		
2D	862838200	02405	3	BRUSH, 12" SUPER AGG SD		
3	86005070	51284	1	LOCK, PAD CENTER SNAP, TWO STEP		
4	86276590	70695	3	SCR, #12 X 1 PPHSMS SS		
5	86276580	70694	1	SCR, 8-32 X 3/4 PTHMS		
6	86276600	70696	3	SCR, #10 X 3/4 PTHSMS SS		
7	86007910	73817	1	SPRING, EXT .31 D X 2.0 L X .03 W SS		
8	86007280	730011	1	SOCKET, DRIVE BRUSH		
9	86005940	62852	1	PLATE, BRUSH RELEASE		

SCRUB DECK GROUP

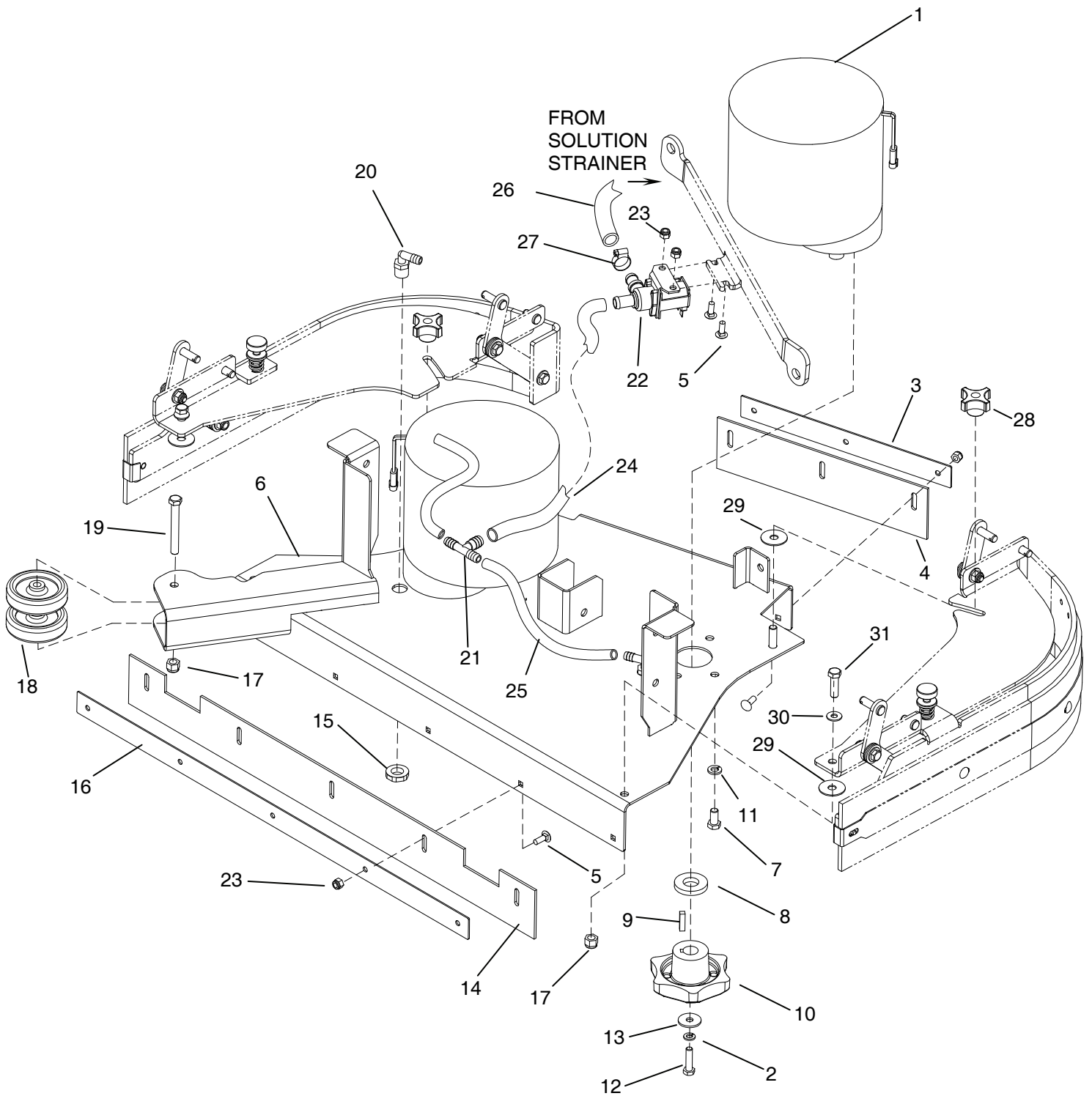

SCRUB DECK GROUP

REF	PART NO.	PRV NO.	QTY	DESCRIPTION	SERIAL NO. FROM	NOTES:
1	86005250	53258	2	MOTOR ASM, 36V 330 RPM GEAR		
1A	86001890	14418	REF	BRUSH SET, MOTOR		SERVICE ONLY
2	86279130	87083	2	WASHER, 5/16 SPLIT		
3	86087940	730104	1	STRAP, REAR SQUEEGEE		
4	86253910	730101	1	SKIRT, REAR		
5	86276950	70772	10	SCR, 1/4-20 X 3/4 CARRIAGE SS		
6	86093960	62962	1	SCRUB DECK, 28 SMALL RIDER		
7	86276970	70774	8	SCR, 3/8-16 X 3/4 HHCS SS		
8	86279530	87173	2	WASHER, .765 ID X 1.31 OD X .090 T SS		
9	86004810	48040	2	KEY, 1/4 SQ X 1.00		
10	86003420	29220	2	DRIVER, BRUSH SD		
11	86010790	87163	8	WASHER, 3/8 SPLIT LOCK		
12	86007020	70673	2	SCR, 5/16-18 X 1.25 HHCS SS		
13	86279630	87212	2	WASHER, .344ID X 1.13OD X .09T		
14	86253900	730099	1	SKIRT, FRONT		
15	86271830	57283	2	NUT, 3/8 NPT PLASTIC		
16	86087930	730103	1	STRAP, FRONT SQUEEGEE		
17	86005630	57022	3	NUT, 3/8-16 HEX NYLOCK THIN SS		
18	86010890	89059	2	WHEEL, BUMPER		
19	86276400	70642	1	SCR, 3/8-16 X 3 HHCS		
20	86001550	40043	2	HOSEBARB, 3/8MPT X 3/8 90D		
21	86003580	34327	1	FITTING, 1/8" X 3/8" X 3/8" RED		
22	86009710	82312	1	VALVE, 36VDC SOL. 1/2" HOSEBARB		
-	86003460	29260	-	DIAPHRAGM SRVC PART SLND		SERVICE ONLY
-	86136820	47395	-	SOLENOID SPRING KIT		SERVICE ONLY
23	86005810	57245	10	NUT, 1/4-20 HEX NYLOCK SS		
24	86281480	39390	1	HOSE, 1/2 ID NYLOBRAID 14"		
25	86280860	39053	2	HOSE, 3/8 NYLOBRAID X 7"		
26	86282180	39613	1	HOSE, 1/2 ID NYLOBRAID X 17"		
27	86233150	20042	1	CLAMP, 3/8 HOSE (D-SLOT)		
28	86009200	81535	2	KNOB, 3/8-16 4 PRONG ALUM		
29	86279620	87200	4	WASHER, .4 ID X 1.3 OD NYLON		
30	86010770	87143	2	WASHER, 7/16 ID X 1 D X .08 FLT SS		
31	86276920	70755	2	SCR, 3/8-16 X 1 HHCS SS NP		

SCRUB DECK SIDE SQUEEGEE GROUP

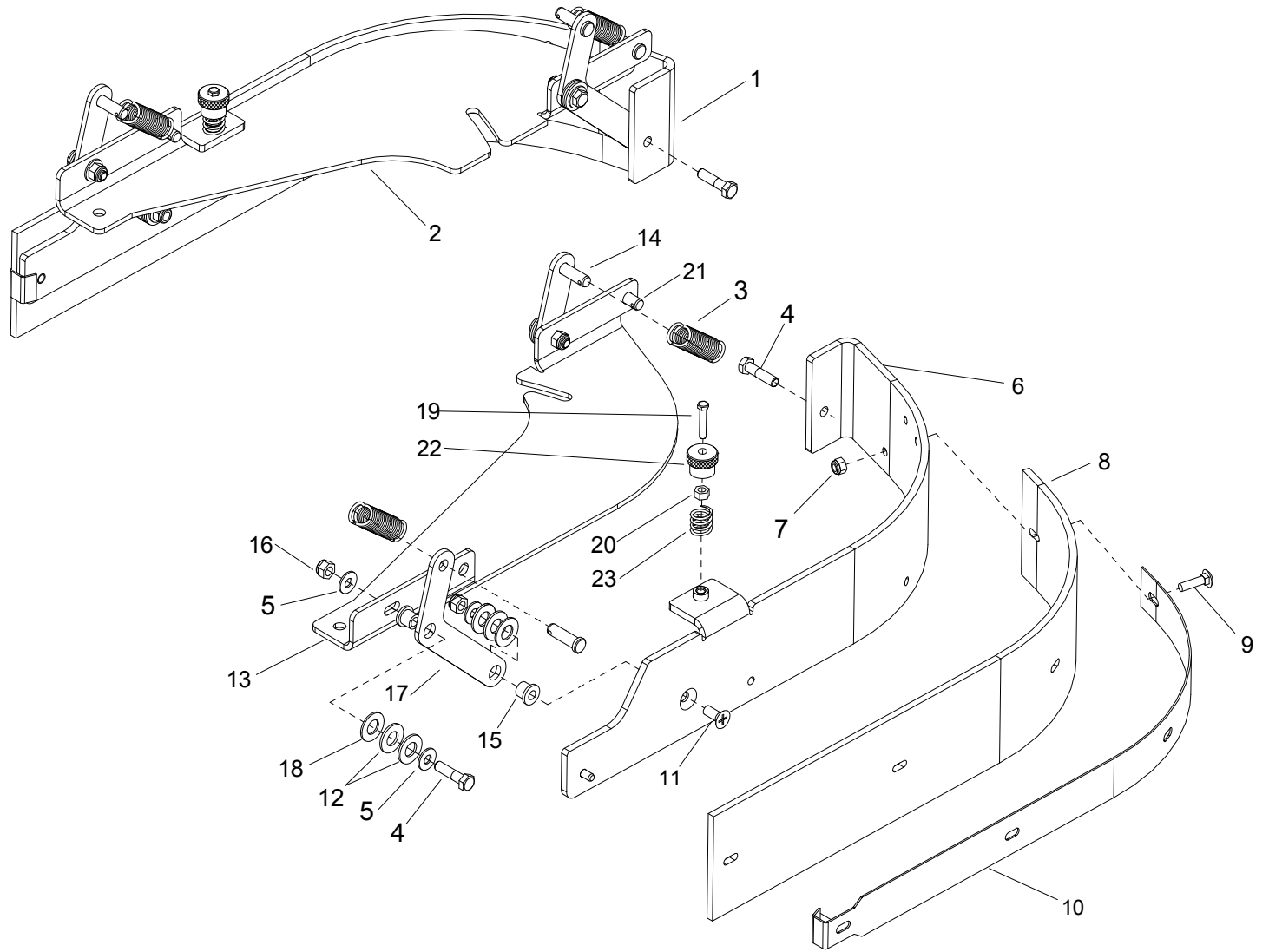

SCRUB DECK SIDE SQUEEGEE GROUP

REF	PART NO.	PRV NO.	QTY	DESCRIPTION	SERIAL NO. FROM	NOTES:
1	86094220	730106	1	SKIRT, RIGHT		
2	86082160	62923	1	PLATE, RIGHT DECK		
3	86226830	73268	4	SPRING, EXT .68D X 3.00L X .098W		
4	86007020	70673	6	SCR, 5/16-18 X 1.25 HHCS SS		
5	86010670	87029	10	WASHER, 5/16 FLAT SS		
6	86094230	730107	1	SKIRT, LEFT		
7	86005810	57245	6	NUT, 1/4-20 HEX NYLOCK SS		
8	86007420	730100	2	SQUEEGEE, SIDE BLADE LINATEX		
9	86276960	70773	6	SCR, 1/4-20 X1.0 CARRIAGE SS		
10	86087920	730102	2	STRAP, SIDE SQUEEGEE		
11	86276900	70753	2	SCR, 5/16-18 X 1.25 PFHMS SS NP		
12	86279380	87146	16	WASHER, 1/2" ID X 1" D X .08" NYL		
13	86082170	62924	1	PLATE, LEFT DECK		
14	86272580	80638	4	PIN, CLEVIS 3/8" X 1.25" PLTD		
15	86228840	09124	8	BEARING, FLANGED .314 D X .502 OD		
16	86270830	57023	8	NUT, 5/16-18 HEX NYLOCK SS		
17	86065960	05162	4	ARM, SKIRT LINKAGE		
18	86259410	87206	8	WASHER, THRUST .51 ID X 1 OD X .063		
19	86277090	70786	2	SCR, 5/16-18 X 3 HHMS FL THD SS		
20	86005650	57031	2	NUT, 5/16-18 HEX		
21	86272380	66217	4	PIN, CLEVIS 3/8 X 3/4		
22	86242120	48090	2	KNOB, 1.0 OD X 5/16-18		
23	86226810	73245	2	SPRING, COMP .72D X 2.0L X .067W		

SCRUB DECK LIFT GROUP

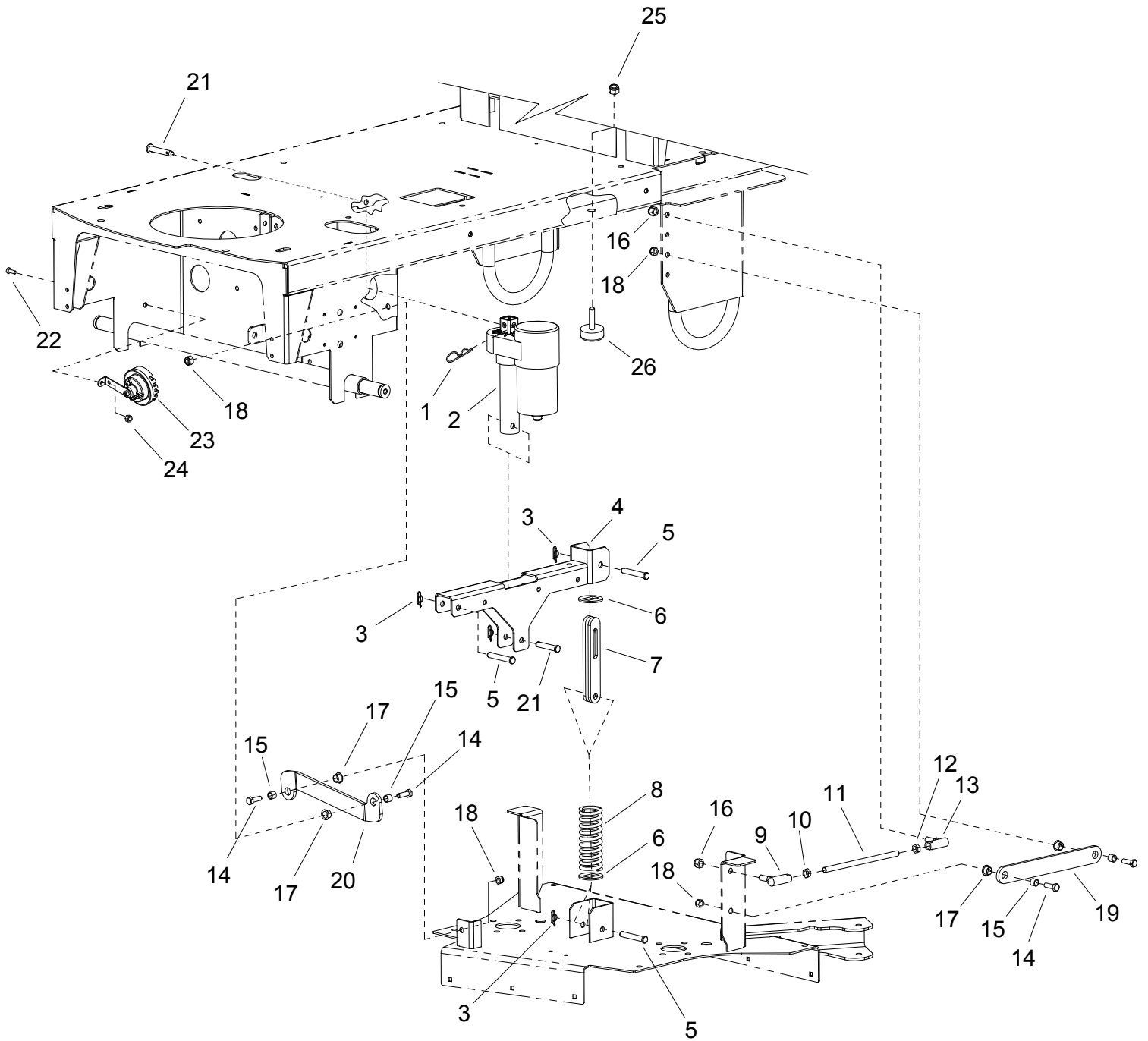

SCRUB DECK LIFT GROUP

REF	PART NO.	PRV NO.	QTY	DESCRIPTION	SERIAL NO. FROM	NOTES:
1	86272600	80657	1	PIN, COTTER, HAIR. 148" DIA X 3/4	*(2)	
2	86352950	-	1	ACTUATOR, 36VDC, 2.0 STROKE	*(7)	
3	86008670	80606	4	COTTER, 3/8" RING		
4	86092250	29254	1	DECK LIFT ASM		
5	86008720	80637	3	PIN, CLEVIS 3/8" X 2.375 PLTD		
6	86090270	87204	2	WASHER, RECTANGULAR HOLE		
7	86077470	51362	2	LINK, DECK LIFT		
8	86254880	730005	1	SPRING, COMP 1.687OD X 4.5L X .234W		
9	86001320	140353	2	BALL JOINT ASSY, 3/8-24 LH		
10	86005830	57263	2	NUT, 3/8-24 UNF LH		
11	86006440	67415	2	ROD, SCRUB LIFT		
12	86005800	57217	2	NUT, 3/8-24 HEX JAM		
13	86008810	80697	2	BALL JOINT ASSY, 3/8-24 RH		
14	86276920	70755	6	SCR, 3/8-16 X 1 HHCS SS NP		
15	86008460	80102	6	SPACER, .500OD X .391ID X .400		
16	86271530	57216	4	NUT, 3/8-24 HEX NYLOCK		
17	86009050	81324	6	BEARING, 1/2ID X 11/32L NYLON		
18	86005630	57022	6	NUT, 3/8-16 HEX NYLOCK THIN SS		
19	86077330	31373	2	LINKAGE, .25 X 1.25 X 9.25		
20	86066790	140503	1	BAR, PANHARD		
21	86248970	81406	2	PIN, CLEVIS 3/8 X 2		
22	86276780	70728	1	SCR, 5-16-18 X 3/4 HHCS SS		
23	86008550	80583	1	HORN, 36VDC		
24	86270830	57023	1	NUT, 5/16-1/8 HEX NYLOCK SS		
25	86005740	57112	2	NUT, 5/16-18 SERRATED FLG		
26	86008740	80654	2	BUMPER, ADJUSTMENT		

*SEE SERIAL NUMBER PAGE.

SCRUB DECK -32 IN

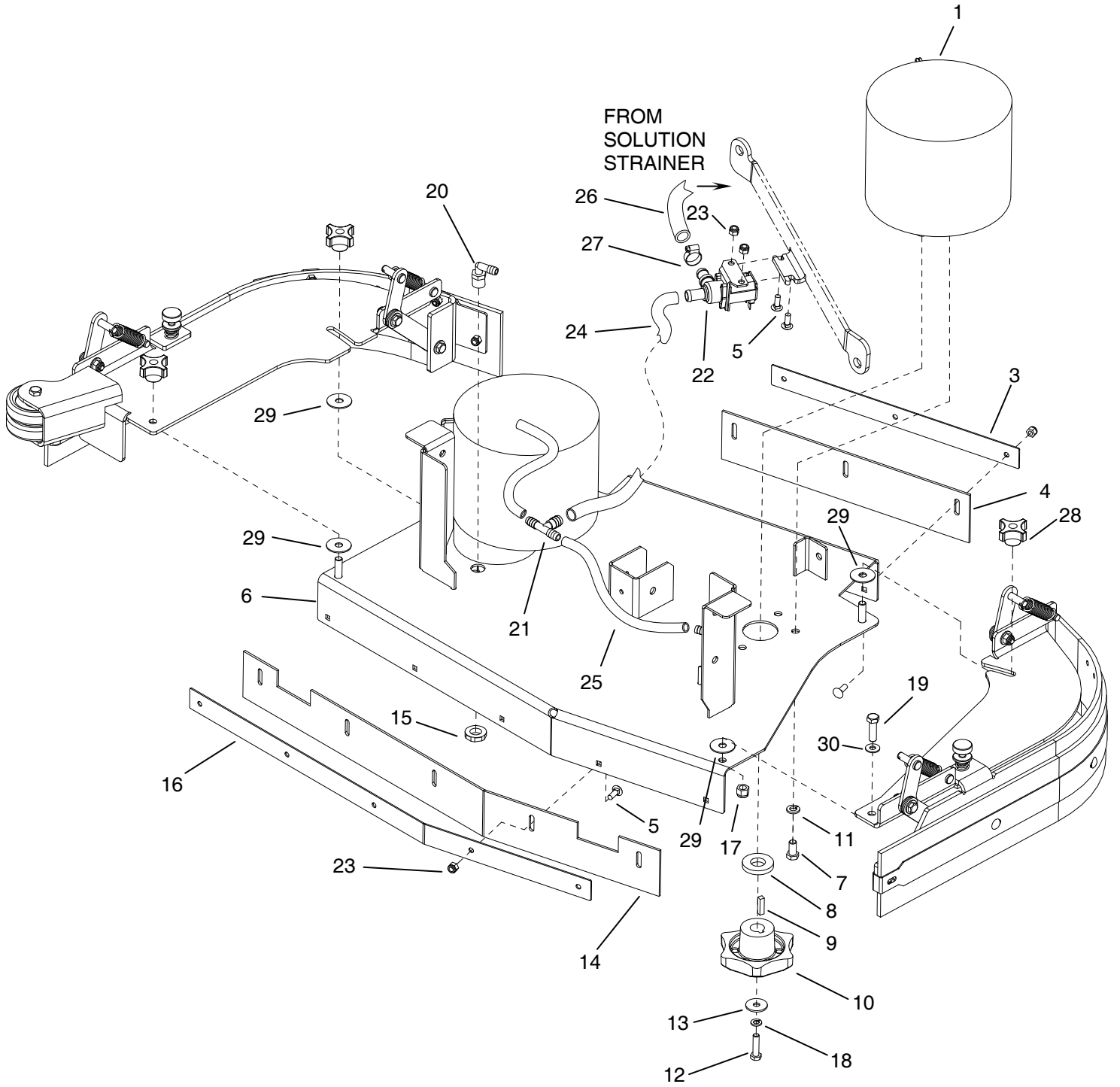

SCRUB DECK -32 IN

REF	PART NO.	PRV NO.	QTY	DESCRIPTION	SERIAL NO. FROM	NOTES:
1	86005250	53258	2	MOTOR ASM, 36V 330 RPM GEAR		
1A	86001890	14418	REF	BRUSH SET, MOTOR		SERVICE ONLY
2	86273810	70018	2	SCR, 1/4-20 X 1 HHCS SS		
3	86087950	730157	1	STRAP, 32 IN REAR SQUEEGEE		
4	86253950	730158	1	SKIRT, 32 IN REAR		
5	86276950	70772	10	SCR, 1/4-20 X 3/4 CARRIAGE SS		
6	86093980	730155	1	SCRUB DECK, 32 SMALL RIDER		
7	86276970	70774	8	SCR, 3/8-16 X 3/4 HHCS SS		
8	86279530	87173	2	WASHER, .765 ID X 1.31 OD X .09 T SS		
9	86004810	48040	2	KEY, 1/4 SQ X 1.00		
10	86003420	29220	2	DRIVER, BRUSH SD		
11	86010790	87163	8	WASHER, 3/8 SPLIT LOCK		
12	86007020	70673	2	SCR, 5/16-18 X 1.25 HHCS SS		
13	86279630	87212	2	WASHER, .344ID X 1.13OD X .09T		
14	86253900	730099	1	SKIRT, FRONT		
15	86271830	57283	2	NUT, 3/8 NPT PLASTIC		
16	86087930	730103	1	STRAP, FRONT SQUEEGEE		
17	86005630	57022	1	NUT, 3/8-16 HEX NYLOCK THIN SS		
18	86279130	87083	2	WASHER, 5/16 SPLIT		
19	86276920	70755	1	SCR, 3/8-16 X 1 HHCS SS NP		
20	86001550	40043	2	HOSEBARB, 3/8MPT X 3/8 90D		
21	86003580	34327	1	FITTING, 1/8" X 3/8" X 3/8" RED		
22	86009710	82312	1	VALVE, 36VDC SOL. 1/2" HOSEBARB		
-	86003460	29260	-	DIAPHRAGM SRVC PART SLND		SERVICE ONLY
-	86136820	47395	-	SOLENOID SPRING KIT		SERVICE ONLY
23	86005810	57245	10	NUT, 1/4-20 HEX NYLOCK SS		
24	86281480	39390	1	HOSE, 1/2 ID NYLOBRAID 14"		
25	86280860	39053	2	HOSE, 3/8 NYLOBRAID X 7"		
26	86282180	39613	1	HOSE, 1/2 ID NYLOBRAID X 17"		
27	86233150	20042	1	CLAMP, 3/8 HOSE (D-SLOT)		
28	86009200	81535	3	KNOB, 3/8-16 4 PRONG ALUM		
29	86279620	87200	4	WASHER, .4 ID X 1.3 OD NYLON		
30	86010770	87143	1	WASHER, 7/16 ID X 1 D X .08 FLT SS		

SCRUB DECK SIDE SQUEEGEE -32 IN

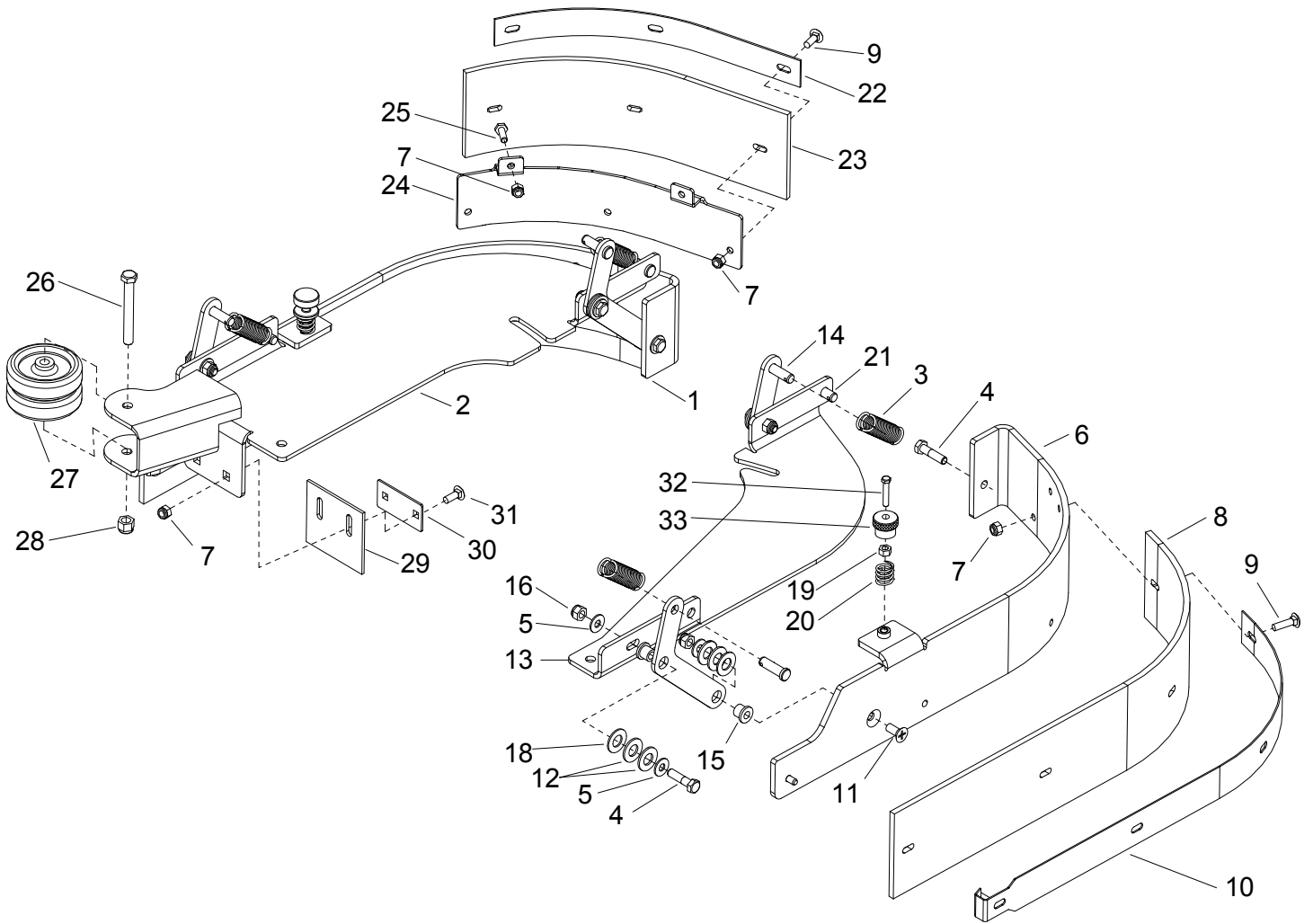

SCRUB DECK SIDE SQUEEGEE -32 IN

REF	PART NO.	PRV NO.	QTY	DESCRIPTION	SERIAL NO. FROM	NOTES:
1	86094220	730106	1	SKIRT, RIGHT		
2	86086840	730156	1	SCRUB DECK 32 SIDE SQUEEGEE		
3	86226830	73268	4	SPRING, EXT .68D X 3.00L X .098W		
4	86007020	70673	6	SCR, 5/16-18 X 1.25 HHCS SS		
5	86010670	87029	10	WASHER, 5/16 FLAT SS		
6	86094230	730107	1	SKIRT, LEFT		
7	86005810	57245	13	NUT, 1/4-20 HEX NYLOCK SS		
8	86007420	730100	2	SQUEEGEE, SIDE BLADE LINATEX		
9	86276320	70633	9	SCR, 1/4-20 X1.0 CARRIAGE BZ		
10	86087920	730102	2	STRAP, SIDE SQUEEGEE		
11	86276900	70753	2	SCR, 5/16-18 X 1.25 PHFMS SS		
12	86279380	87146	16	WASHER, 1/2" ID X 1" D X .08" NYL		
13	86082170	62924	1	PLATE, LEFT DECK		
14	86272580	80638	4	PIN, CLEVIS 3/8" X 1.25" PLTD		
15	86228840	09124	8	BEARING, FLANGED .314 D X .502 OD		
16	86270830	57023	8	NUT, 5/16-18 HEX NYLOCK SS		
17	86065960	05162	4	ARM, SKIRT LINKAGE		
18	86259410	87206	10	WASHER, THRUST .51 ID X 1 OD X .063		
19	86005650	57031	2	NUT, 5/16-18 HEX		
20	86226810	73245	2	SPRING, COMP .72D X 2.0L X .067W		
21	86272380	66217	4	PIN, CLEVIS 3/8 X 3/4		
22	86087960	730166	1	STRAP, 32 IN SIDE SQUEEGEE		
23	86007580	730167	1	SQUEEGEE, 32 SIDE BLADE		
24	86001480	140584	1	BRKT, 32 SIDE SQUEEGEE		
25	86273780	70015	2	SCR, 1/4-20 X 3/4 HHCS SS NP		
26	86276400	70642	1	SCR, 3/8-16 X 3 HHCS		
27	86010890	89059	2	WHEEL, BUMPER		
28	86005630	57022	1	NUT, 3/8-16 HEX NYLOCK THIN SS		
29	86253960	730169	1	SKIRT, 32 IN SIDE DECK		
30	86087970	730168	1	STRAP, 32 IN SIDE DECK		
31	86276950	70772	2	SCR, 1/4-20 X 3/4 CARRIAGE SS		
32	82677090	70786	2	SCR, 5/16-18 X 3 HHMS FL THD SS		
33	86242120	48090	2	KNOB, 1.0 OD X 5/16-18		

SCRUB DECK-36 IN MAIN

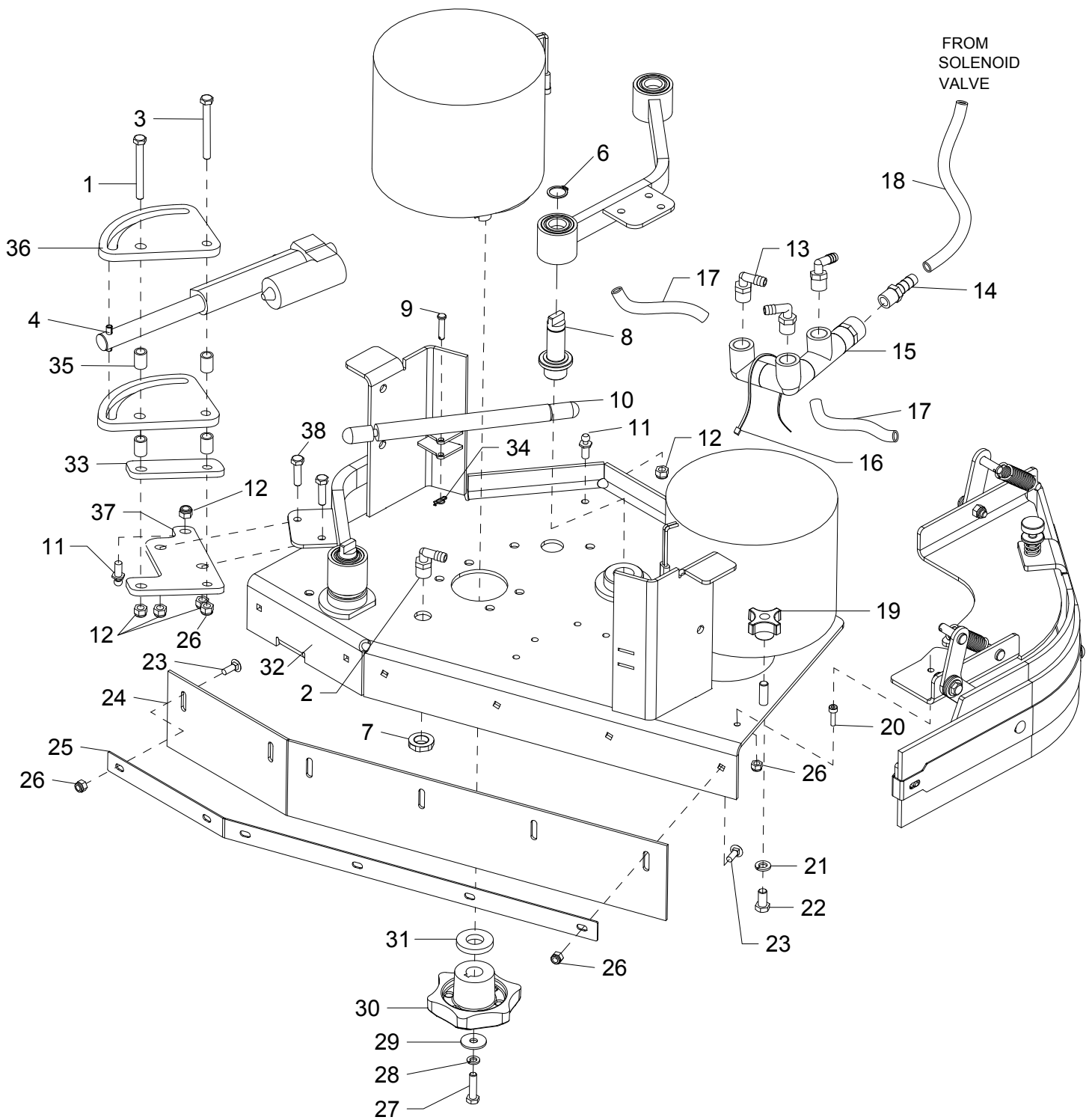

SCRUB DECK-36 IN MAIN

REF	PART NO.	PRV NO.	QTY	DESCRIPTION	SERIAL NO. FROM	NOTES:
1	86276910	70754	1	SCR, 5/16-18 X 3 HHCS SS NP		
2	86001550	40043	2	HOSEBARB, 3/8 MPT X 3/8 90 D		
3	86273960	70061	1	SCR, 1/4-20 X 3 HHCS F. THD SS		
4	86000840	05171	1	ACTUATOR ASM		
5	86005250	53258	2	MOTOR ASM, 36V 330 RPM GEAR		
5A	86001890	14418	REF	BRUSH SET, MOTOR		SERVICE ONLY
6	86223470	67449	2	RING, 20MM EXTERNAL SNAP		
7	86271830	57283	2	NUT, 3/8 NPT PLASTIC		
8	86253250	730152	2	SHAFT, PIVOT		
9	86272620	80670	1	PIN, CLEVIS 1/4 X 1.125 PLTD		
10	86007570	730165	1	SPRING, GAS 300 NEWTONS		
11	86256500	80649	2	STUD, BALL GAS SPRING		
12	86270830	57023	5	NUT, 5/16-18 HEX NYLOCK SS		
13	86236170	34277	3	FITTING, 1/2 MPT X 3/8 BARB 90		
14	86197910	40022	1	HOSEBARB, 1/2 MPT X 1/2 POLY DL		
15	86033220	54185	1	MANIFOLD, SOLUTION FEED SRS		
16	86264920	27049	2	CABLE TIE, 7"		
17	86281410	39361	2	HOSE, 3/8 NYLOBRAID X 7.5		
18	86281480	39390	1	HOSE, 1/2 ID NYLOBRAID X 14"		
19	86009200	81535	1	KNOB, 3/8-16 4 PRONG ALUM		
20	86274110	70094	1	SCR, 1/4-20 X 1/2 SHCS		
21	86010790	87163	8	WASHER, 3/8 SPLIT LOCK		
22	86276970	70774	8	SCR, 3/8-16 X 3/4 HHCS		
23	86276950	70772	6	SCR, 1/4-20 X 3/4 CARRIAGE SS		
24	86007410	730098	1	SKIRT, FRONT 36" DECK		
25	86087900	730090	1	STRAP, FRONT SKIRT		
26	86005810	57245	8	NUT, 1/4-20 HEX NYLOCK SS		
27	86007020	70673	2	SCR, 5/16-18 X 1.25 HHCS SS		
28	86279130	87083	2	WASHER, 5/16 SPLIT LOCK PLTD		
29	86279630	87212	2	WASHER, .344 ID X 1.13 OD X .09 T		
30	86003420	29220	2	DRIVER, BRUSH SD		
31	86279530	87173	2	WASHER, .765 ID X 1.31 OD X .09 T SS		
32	86093970	730111	1	SCRUB DECK, 36" MIN		
33	86087280	730183	1	SPACER, PLATE		
34	86008650	80604	1	COTTER, 1/4 RING		
35	86087290	730195	4	SPACER, .5OD X .334ID X .860L		
36	86082570	62993	2	PLATE, ACTUATOR RETAINER		
37	86070300	140610	1	BRKT, ACTUATOR RETAINER		
38	86276780	70728	2	SCR, 5/16-18 X 3/4 HHCS SS		

SCRUB DECK-36 IN RETRACTABLE

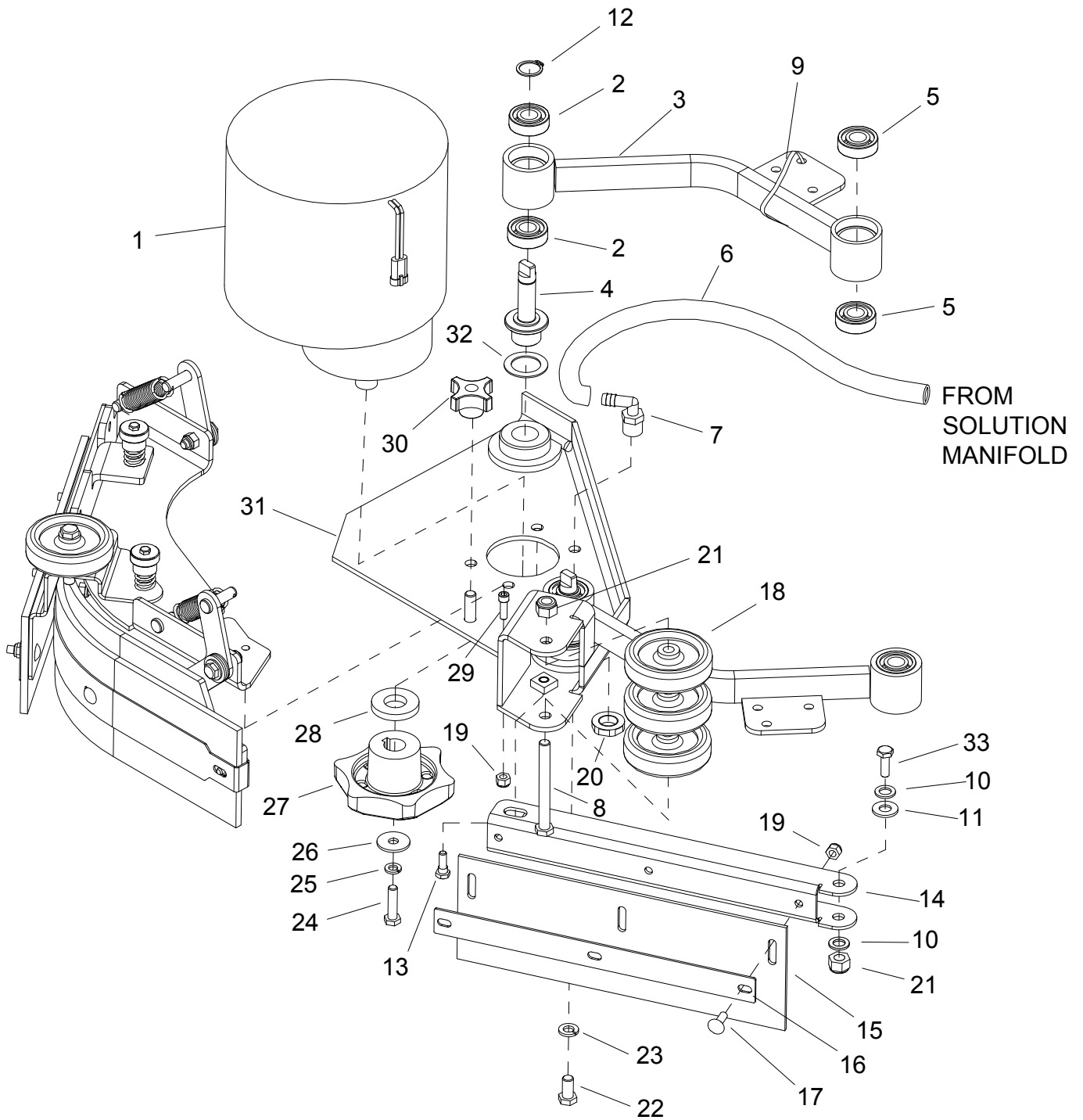

SCRUB DECK-36 IN RETRACTABLE

REF	PART NO.	PRV NO.	QTY	DESCRIPTION	SERIAL NO. FROM	NOTES:
1	86005250	53258	1	MOTOR ASM, 36V 330 RPM GEAR		
1A	86001890	14418	REF	BRUSH SET, MOTOR		SERVICE ONLY
2	86009550	82045	4	BEARING, 1.38 X .59 X .43 L SS		
3	86093020	05165	2	LINKAGE, SWING		
4	86009520	82035	2	SHAFT, DRIVER CYL. SCRUB		
5	86228930	09145	4	BEARING, BALL 20MM X 37MM		
6	86281440	39365	1	HOSE, 3/8 ID NYLOBRAID X 25"		
7	86001550	40043	1	HOSEBARB, 3/8 MPT X 3/8 90 D		
8	86277860	70787	1	SCR, 3/8-16 X 3.75 HHCS SS		
9	86264920	27049	1	CABLE TIE, 7"		
10	86010770	87143	2	WASHER, 7/16 ID X 1 D X .08 FLT SS		
11	86279620	87200	1	WASHER, .41 D X 1.3 OD NYLON		
12	86007670	73166	2	SNAP RING, EXTERNAL		
13	86278130	70737	1	SHOULDER BOLT, 3/8 X 3/8 SS		
14	86069540	140472	1	BRKT, SWING SKIRT CHANNEL		
15	86007400	730095	1	SKIRT, SWING BLADE		
16	86087910	730091	1	STRAP, SWING SKIRT		
17	86276950	70772	3	SCR, 1/4-20 X 3/4 CARRIAGE		
18	86010890	89059	3	WHEEL, BUMPER		
19	86005810	57245	4	NUT, 1/4-20 HEX NYLOCK SS		
20	86271830	57283	1	NUT, 3/8 NPT PLASTIC		
21	86005630	57022	2	NUT, 3/8-16 HEX NYLOCK THIN SS		
22	86276970	70774	4	SCR, 3/8-16 X 3/4 HNCS SS		
23	86010790	87163	4	WASHER, 3/8 SPLIT LOCK		
24	86007020	70673	1	SCR, 5/19-18 X 1.25 HHCS SS		
25	86279130	87083	1	WASHER, 5/16 SPLIT LOCK PLTD		
26	86279630	87212	1	WASHER, .344 ID X 1.12 OD X .09 T PLT		
27	86003420	29220	1	DRIVER, BRUSH SD		
28	86279530	87173	1	WASHER, .765 ID X 1.31 OD X .09 T SS		
29	86274110	70094	1	SCR, 1/4-20 X 1/2 SHCS		
30	86009200	81535	1	KNOB, 3/8-16 4 PRONG ALUM		
31	86094490	730110	1	SWING, DECK ASM		
32	86278870	80634	2	WASHER, 1.015 ID X 1.5 D X .055 T		
33	86276470	70652	1	SCR, 3/8-16 X 2.25 HHCS SS		

SCRUB DECK SIDE SQUEEGEE-36 IN

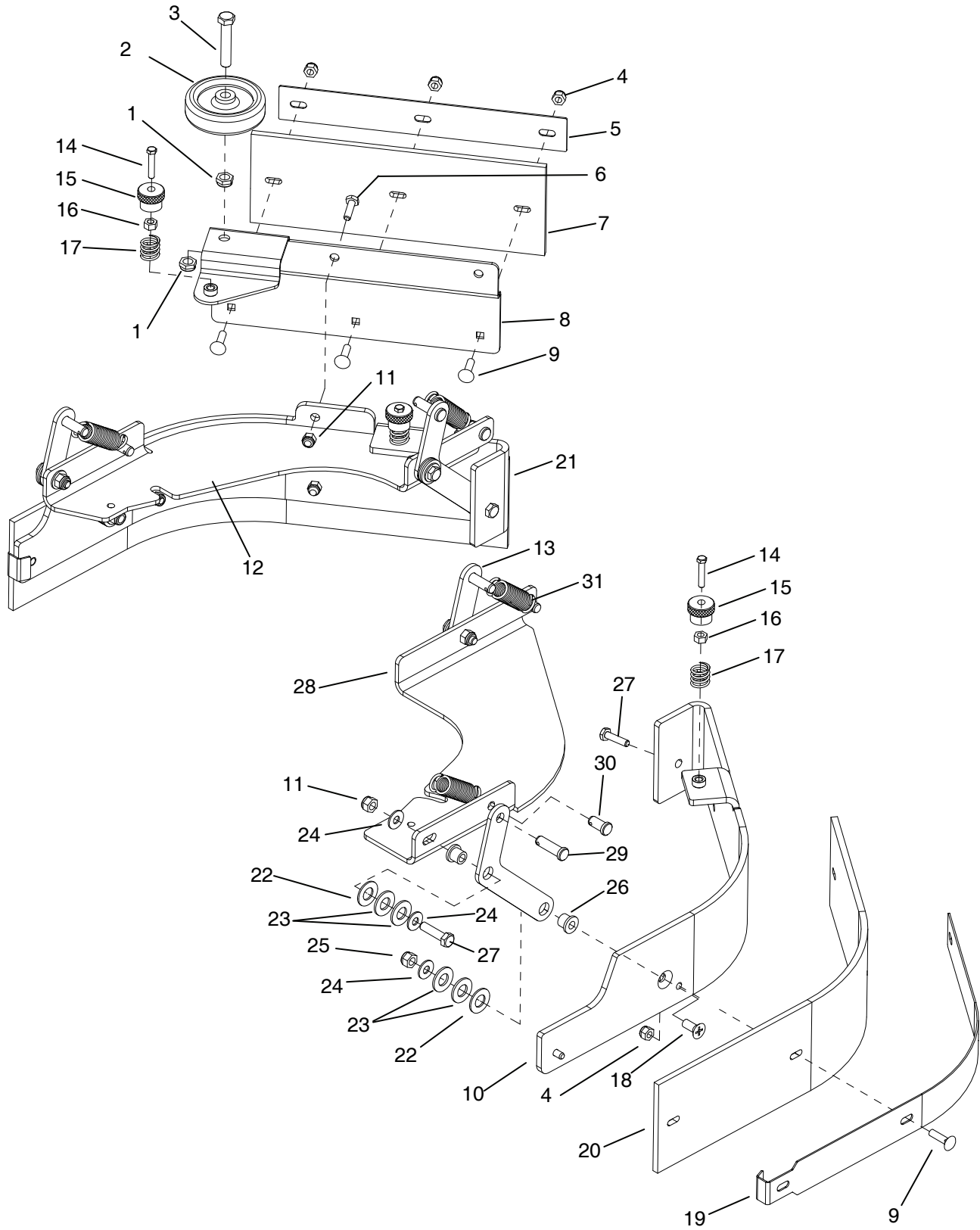

SCRUB DECK SIDE SQUEEGEE-36 IN

REF	PART NO.	PRV NO.	QTY	DESCRIPTION	SERIAL NO. FROM	NOTES:
1	86005630	57022	2	NUT, 3/8-16 HEX NYLOCK THIN SS		
2	86010890	89059	1	WHEEL, BUMPER		
3	86274010	70070	1	SCR, 3/8-16 X 2 HHCS		
4	86005810	57245	9	NUT, 1/4-20 HEX NYLOCK SS		
5	86087860	62944	1	STRAP, SECONDARY SQUEEGEE		
6	86276780	70728	2	SCR, 5/16-08 X 3/4 HHCS SS		
7	86007550	730154	1	SQUEEGEE BLADE, SECONDARY		
8	86069580	140478	1	BRKT, SECONDARY SQUEEGEE		
9	86276960	70773	9	SCR, 1/4-20 X 1 CARRIAGE SS		
10	86083740	730094	1	PLATE, SQUEEGEE LEFT		
11	86270830	57023	6	NUT, 5/16-18 HEX NYLOCK SS		
12	86082220	62934	1	PLATE, RIGHT SQUEEGEE		
13	86065960	05162	4	ARM, SKIRT LINKAGE		
14	86277090	70786	3	SCR, 5/16-18 X 3 HHMS FL THD SS		
15	86242120	48090	3	KNOB, 1.0 OD X 5/16-18		
16	86005650	57031	3	NUT, 5/16-18 HEX		
17	86226810	73245	3	SPRING, COMP .72 X 2.0 L X .067 W		
18	86277120	70792	2	SCR, 5/16-18 X 1.00 PFHMS SS		
19	86087890	730089	2	STRAP, SIDE SQUEEGEE		
20	86007390	730093	2	SQUEEGEE, SIDE BLADE LINATEX		
21	86083730	730092	1	PLATE, SQUEEGEE RIGHT		
22	86259410	87206	8	WASHER, THRUST .51 ID X 1 OD X .063		
23	86279380	87146	16	WASHER 1/2 ID X 1 D X .08 NYL		
24	86010670	87029	10	WASHER, 5/16 FLAT SS		
25	86271840	57285	2	NUT, 5/16-18 HEX NYLOCK THIN SS		
26	86228840	09124	8	BEARING, FLANGED .314 D X .502 OD		
27	86007020	70673	6	SCR, 5/16-18 X 1.25 HHCS SS		
28	86082200	62932	1	PLATE, LEFT SQUEEGEE		
29	86272580	80638	4	PIN, CLEVIS 3/8 X 1.25 PLTD		
30	86272380	66217	4	PIN, CLEVIS 3/8 X 3/4 PLTD		
31	86226830	73268	4	SPRING, EXT .68D X 3.00L X .098W		

SCRUB DECK LIFT-36 IN

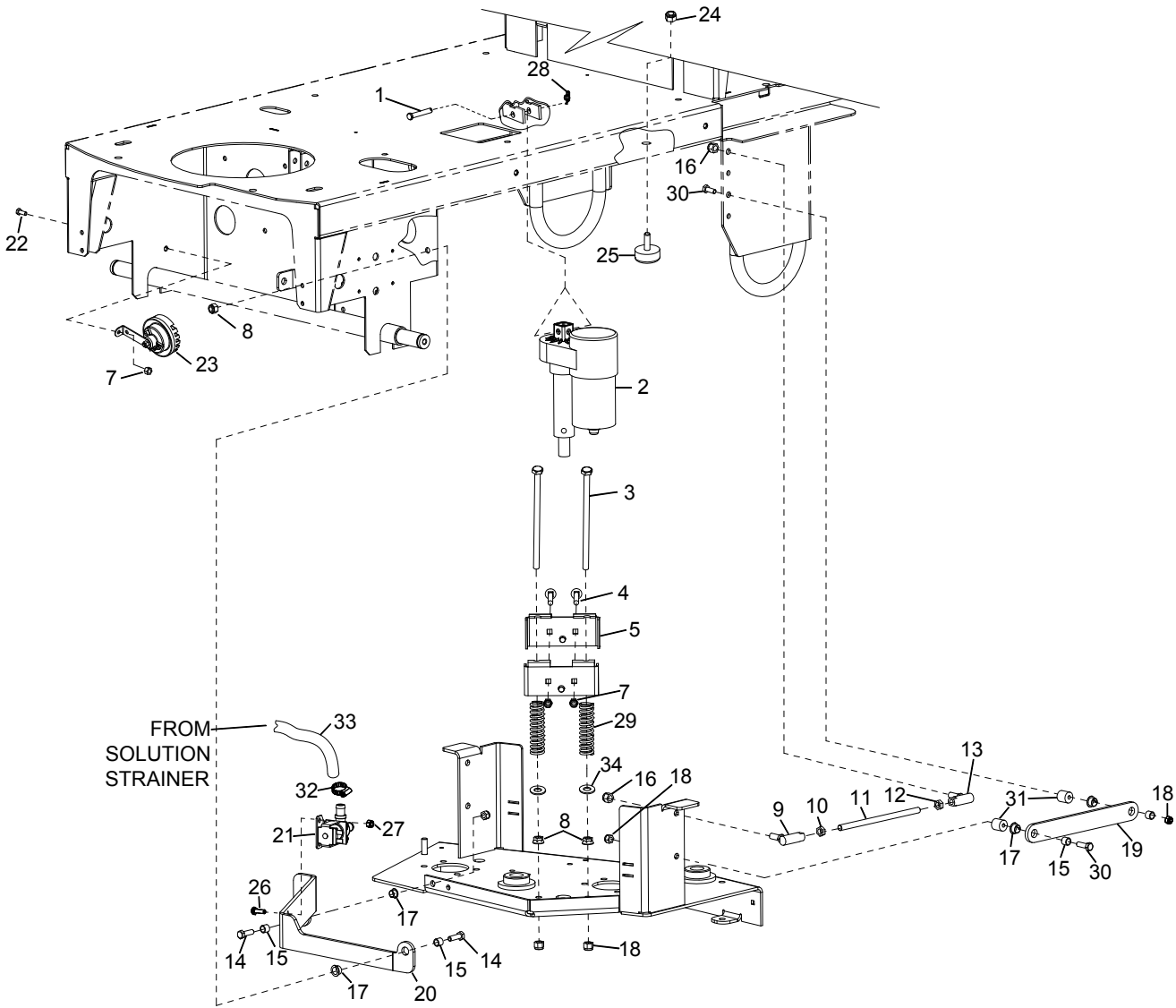

SCRUB DECK LIFT-36 IN

REF	PART NO.	PRV NO.	QTY	DESCRIPTION	SERIAL NO. FROM	NOTES:
1	86008720	80637	1	PIN, CLEVIS 3/8" X 2.375" PLTD		
2	86014490	-	1	ACTUATOR, 36VDC 5.0 STRK SG36	*(3)	WAS 86000830
3	86277860	70787	2	SCR, 3/8-16 X 3.75 HHCS SS		
4	86275960	70570	2	SCR, 5/16-18 X 2.5 CARRIAGE GR5		
5	86091720	140579	2	BRKT, ACTUATOR LIFT SRS		
6	86093970	730111	1	SCRUB DECK, 36" MIN		
7	86270830	57023	3	NUT, 5/16-18 HEX NYLOCK SS		
8	86270880	57032	2	NUT, 3/8-16 SERRATED FLG		
9	86001320	140353	2	BALL JOINT ASSY, 3/8-24 LH		
10	86005830	57263	2	NUT, 3/8-24 UNF LH		
11	86006440	67415	2	ROD, SCRUB LIFT		
12	86005800	57217	2	NUT, 3/8-24 HEX JAM		
13	86008810	80697	2	BALL JOINT ASSY, 3/8-24 RH		
14	86276920	70755	4	SCR, 3/8-16 X 1 HHCS SS NP		
15	86008460	80102	6	SPACER, .500OD X .391ID X .400		
16	86271530	57216	4	NUT, 3/8-24 HEX NYLOCK		
17	86009050	81324	6	BEARING, 1/2ID X 11/32L NYLON		
18	86005630	57022	8	NUT, 3/8-16 HEX NYLOCK THIN SS		
19	86077330	31373	2	LINKAGE, .25 X 1.25 X 9.25		
20	86066780	140500	1	BAR, PANHARD		
21	86009710	82312	1	VALVE, 36VDC SOL 1/2" HOSEBARB		
-	86003460	29260	-	DIAPHRAGM, SRVC PART SLND		SERVICE ONLY
-	86004620	47295	-	SOLENOID SPRING KIT		SERVICE ONLY
22	86276780	70728	1	SCR, 5-16-18 X 3/4 HHCS SS		
23	86008550	80583	1	HORN, 36VDC		
24	86005740	57112	2	NUT, 5/16-1/8 SERRATED FLANGE		
25	86008740	80654	2	BUMPER, ADJUSTMENT		
26	86273780	70015	2	SCR, 1/4-20 X 3/4 HHCS SS NP		
27	86005810	57245	2	NUT, 1/4-20 HEX NYLOCK SS		
28	86008670	80606	1	COTTER, 3/8 RING		
29	86255430	81311	2	SPRING, COMP 1.00 X 3.5 L X .135 W		
30	86274010	70070	2	SCR, 3/8-16 X 2 HHCS		
31	86254250	730163	2	SPACER, 1.0 OD X .391 ID X 1.13 L		
32	86233150	20042	1	CLAMP, 3/8 HOSE		
33	86282060	39563	1	HOSE, 1/2 ID NYLOBRAID X 21.5		
34	86010730	87088	2	WASHER, 5/8 ID X 1.18 X .06 SS		

*SEE SERIAL NUMBER PAGE.

SEAT & SIDE COVER

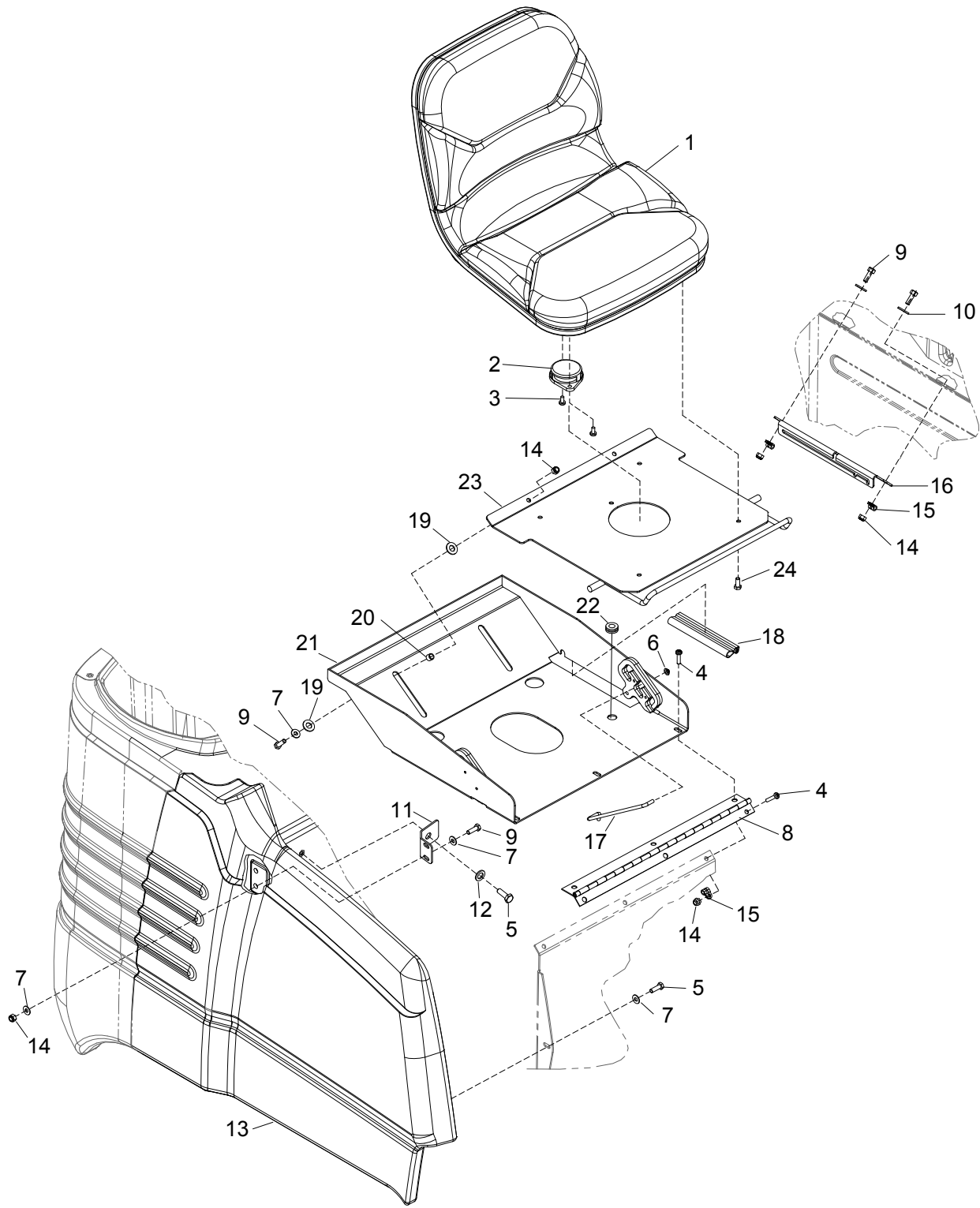

SEAT & SIDE COVER

REF	PART NO.	PRV NO.	QTY	DESCRIPTION	SERIAL NO. FROM	NOTES:
1	86253150	730087	1	SEAT, SUPER SUBURBAN BLK VINYL		
2	86257070	72175	1	SWITCH, SEAT		
3	86006580	70085	2	SCR, 1/4-20 X 1/2 PPHMS SS		
4	86276890	70752	6	SCR, 5/16-18 X 3/4 PTHMS SS		
5	86276780	70728	2	SCR, 5/16-18 X 3/4 HHCS SS		
6	86271240	57154	1	NUT, CAP 1/4 DIA RETAINING PLT		
7	86010670	87029	7	WASHER, 5/16 FLAT SS		
8	86239640	41430	1	HINGE, SMALL RIDER		
9	86006560	70083	6	SCR, 5/16-18 X 1 HHCS SS		
10	86279650	87222	2	WASHER, SEAL 5/16 X 3/4 OD		
11	86069700	140494	1	BRKT, SIDE COVER		
12	86279630	87212	1	WASHER, .344ID X 1.13OD X .09T PLT		
13	86288400	27937	1	COVER, SIDE SMALL RIDER		
14	86270830	57023	7	NUT, 5/16-18 HEX NYLOCK SS		
15	86233440	82857	3	CLAMP, 1/4 CUSHIONED		
16	86069710	140496	1	BRKT, PROP ROD		
17	86086550	67477	1	ROD, PROP		
18	86282780	32053	1	EDGING, SEAT DECK		
19	86279380	87146	4	WASHER, 1/2" ID X 1" D X .08" NYL		
20	86008460	80102	2	SPACER, .500 OD X .91 ID X .400		
21	86093760	62960	1	PLATE, SEAT SLIDE		
22	86238470	80690	1	GROMMET, INSULATION 1/2"		
23	86093750	62959	1	PLATE, ROD ASM		
24	86277040	70781	4	SCR, 5/16-18 X 1/2 HHCS SS NP		

SOLUTION DELIVERY

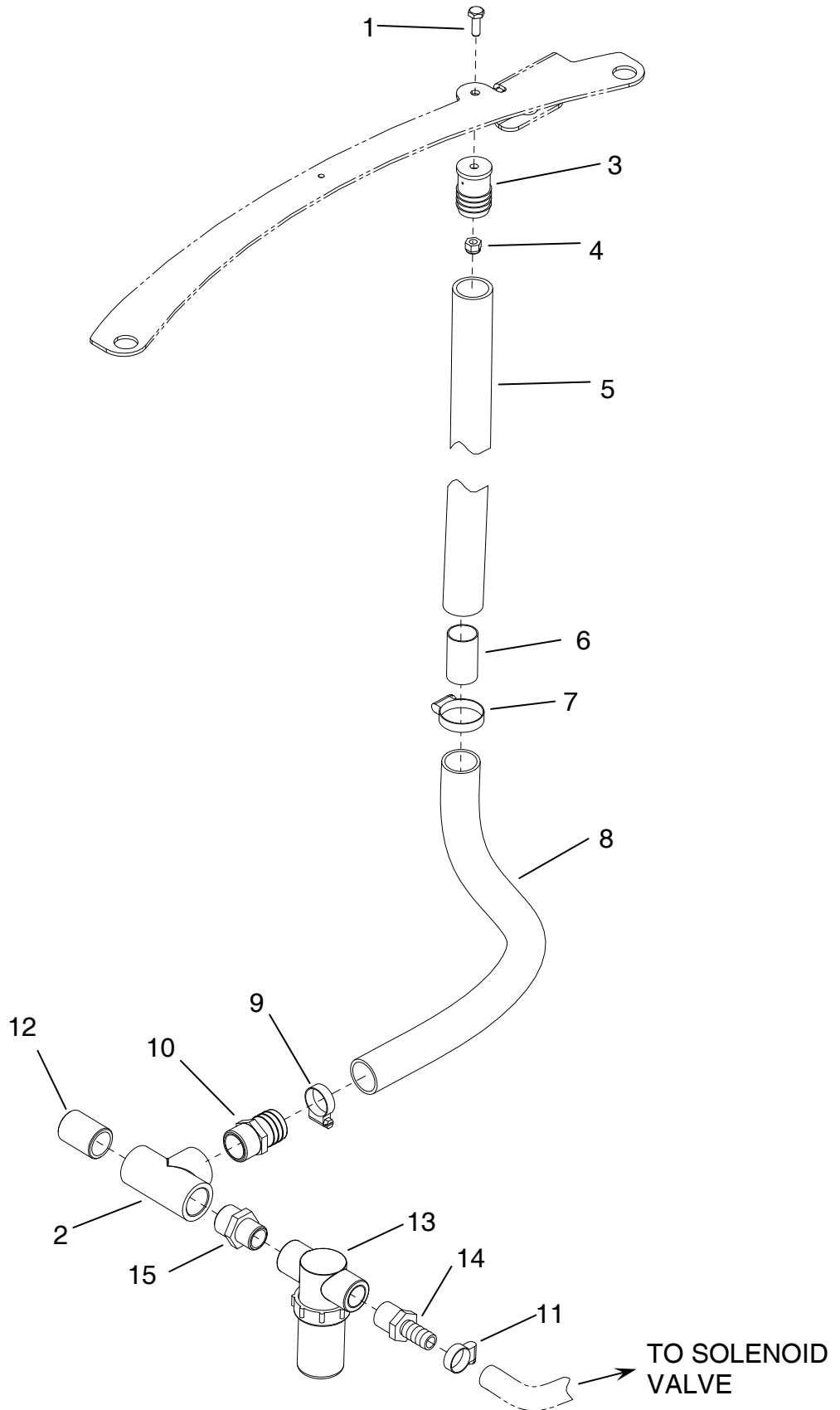

SOLUTION DELIVERY

REF	PART NO.	PRV NO.	QTY	DESCRIPTION	SERIAL NO. FROM	NOTES:
1	86273780	70015	1	SCR, 1/4-20 X 3/4 HHCS SS NP		
2	86198050	81923	1	TEE, 3/4 FPT		
3	86076820	40053	1	HOSEBARB, SOLUTION HOSE MTG		
4	86005810	57245	1	NUT, 1/4-20 HEX NYLOCK SS		
5	86282150	39596	1	HOSE, 1" X 28 VINYL		
6	86236180	34387	1	FITTING, 3/4" COUPLING		
7	86233300	20101	1	CLAMP, 1.25" WORM GEAR SS		
8	86240150	39595	1	HOSE, 1 X 12" DRAIN		
9	86233110	20018	1	CLAMP, 1.0" WORM GEAR		
10	86240330	40051	1	HOSEBARB, 3/4 MPT X 1"H PVC DL		
11	86233150	20042	1	CLAMP, 3/8 HOSE (D-SLOT)		
12	86247760	80960	1	NIPPLE, 3/4 CLOSE		
13	86256040	730151	1	STRAINER, 1/2 FPT 40 MESH		
13A	86007250	730000	REF	STRAINER, DEEP 40 MESH		SERVICE ONLY
13B	86005870	59021	REF	O-RING, FILTER SEAL		SERVICE ONLY
14	86197910	40022	1	HOSEBARB, 1/2 MPT X 1/2 POLY		
15	86236860	82362	1	FITTING, 3/4 MPT X 1/2 MPT REDUCER		

SQUEEGEE – 28 IN & 36 IN

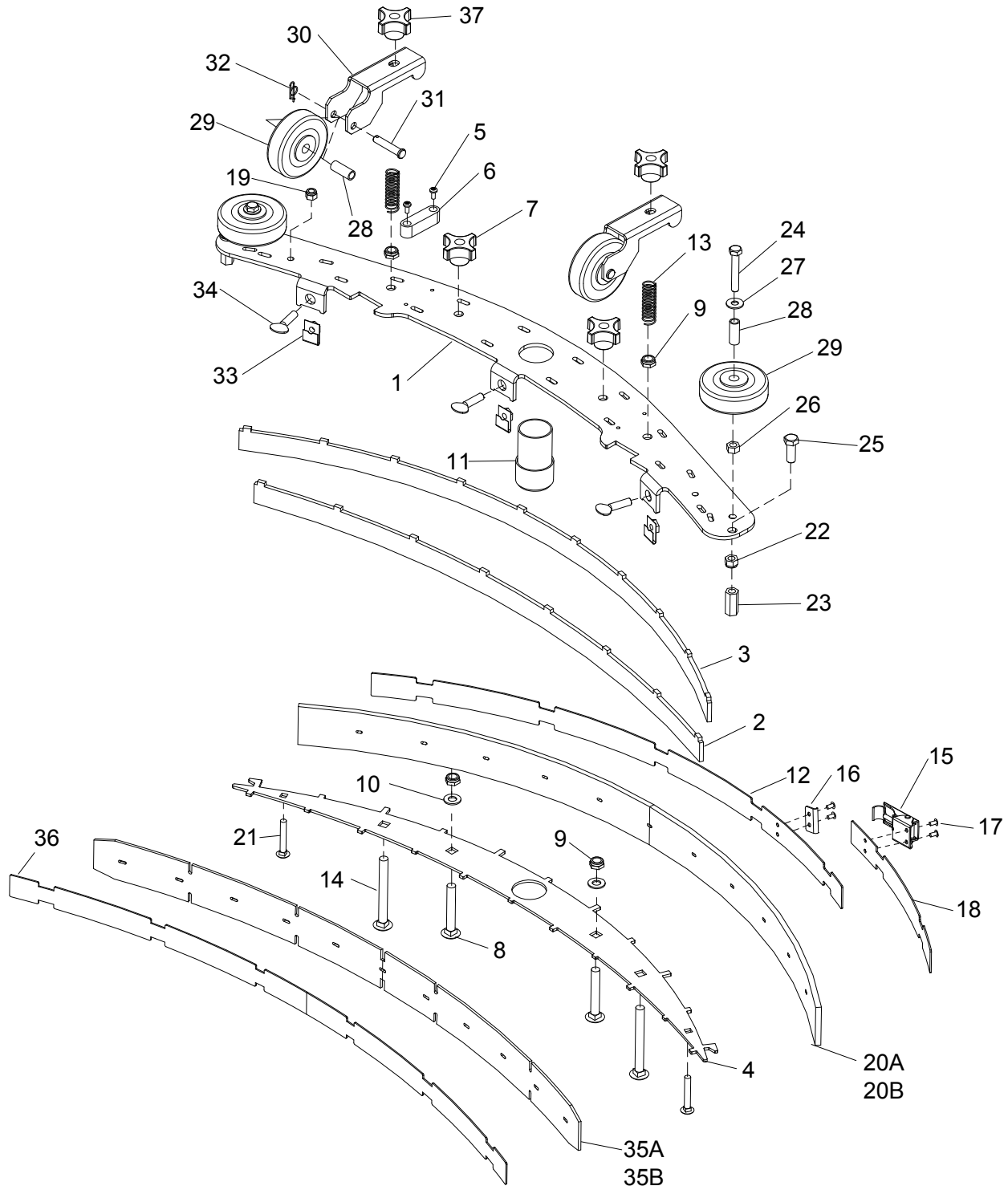

SQUEEGEE -28 IN & 36 IN

REF	PART NO.	PRV NO.	QTY	DESCRIPTION	SERIAL NO. FROM	NOTES:
1	86082500	62979	1	PLATE, SQUEEGEE TOP 32 IN		
2	86082510	62980	1	PLATE, SQG VERTICAL FILLER (F)		
3	86082520	62981	1	PLATE, SQG VERTICAL FILLER (R)		
4	86082530	62982	1	PLATE, SQUEEGEE BOTTOM 32 IN		
5	86274130	70098	2	SCR, 8-32 X 3/8 PHTC 'F' PLTD		
6	86009910	82576	1	VIAL, LEVEL		
7	86009200	81535	2	KNOB, 3/8-16 4 PRONG ALUM		
8	86276870	70748	2	SCR, 3/8-16 X 2.50 CARRIAGE SS		
9	86005630	57022	4	NUT, 3/8-16 HEX NYLOCK THIN SS		
10	86010680	87030	2	WASHER, 3/8ID X 3/4OD NYLON		
11	86008390	78493	1	TUBE ASM, SQUEEGEE VAC		
12	86001850	14413	1	BAND, REAR SQUEEGEE		
13	86007780	73576	2	SPRING, COMP .60D X 2.0L X .045W		
14	86276990	70776	2	SCR, 3/8-16 X 3.5 CARRIAGE SS		
15	86009170	81488	1	LATCH, SQUEEGEE STRAP		
16	86009180	81489	1	STRIKER, SQUEEGEE STRAP REAR		
17	86006400	67380	4	RIVET, 5/32 OF X 1/8 GRIP		
18	86001860	14414	1	BAND, REAR SQUEEGEE		
19	86271870	57290	2	NUT, 1/4-20 HEX NYLOCK THIN SS		
20A	86001440	140533	1	BLADE, SQUEEGEE REAR LINATEX 1/4		
20B	86229610	140585	REF	BLADE, SQUEEGEE REAR GUM 1/4		OPTION
20C	86001880	14416	REF	BLADE, SQUEEGEE REAR LINATEX 3/16		OPTION
20D	86229620	140597	REF	BLADE, SQUEEGEE REAR URETHANE		OPTION
21	86277000	70777	2	SCR, 1/4-20 X 1.5 CARRIAGE SS		
22	86270830	57023	2	NUT, 5/16-18 HEX NYLOCK SS		
23	86005840	57269	2	NUT, 3/8-16 HEX COUPLING SS		
24	86276980	70775	2	SCR, 5/16-18 X 2 HHCS SS		
25	86276920	70755	2	SCR, 3/8-16 X 1 HHCS SS NP		
26	86005650	57031	2	NUT, 5/16-18 HEX		
27	86010670	87029	2	WASHER, 5/16 FLAT SS		
28	86001350	140390	4	BUSHING, SPANNER .435 X 1.10		
29	86011020	89202	4	WHEEL, 3" DIA CUSHION RUBBER		
30	86069870	140531	2	BRACKET, SQG WHEEL		
31	86006270	66276	2	PIN, CLEVIS 5/16 X 1.625 LG		
32	86008660	80605	2	COTTER, 5/16" RING		
33	86271820	57270	3	NUT, 5/16-18 CAPTIVE "J" PLTD		
34	86007040	70680	3	SCR, 5/16-18 X 1 THUMB SS TYPE P		
35A	86001490	140598	1	BLADE, SQUEEGEE FRONT (5-SLOTS)		
35B	86001870	14415	REF	BLADE, SQUEEGEE FRONT (3-SLOTS)		OPTION
36	86001840	14412	1	BAND, SQUEEGEE FRONT		
37	86004890	48095	2	KNOB, ALUM 3/8-16 NYLOCK NUT SS		

NOTE: COMPLETE SQUEEGEE ASSEMBLY IS AVAILABLE, PART NO. 86026550, PRV NO. 47405.

SQUEEGEE 32-IN

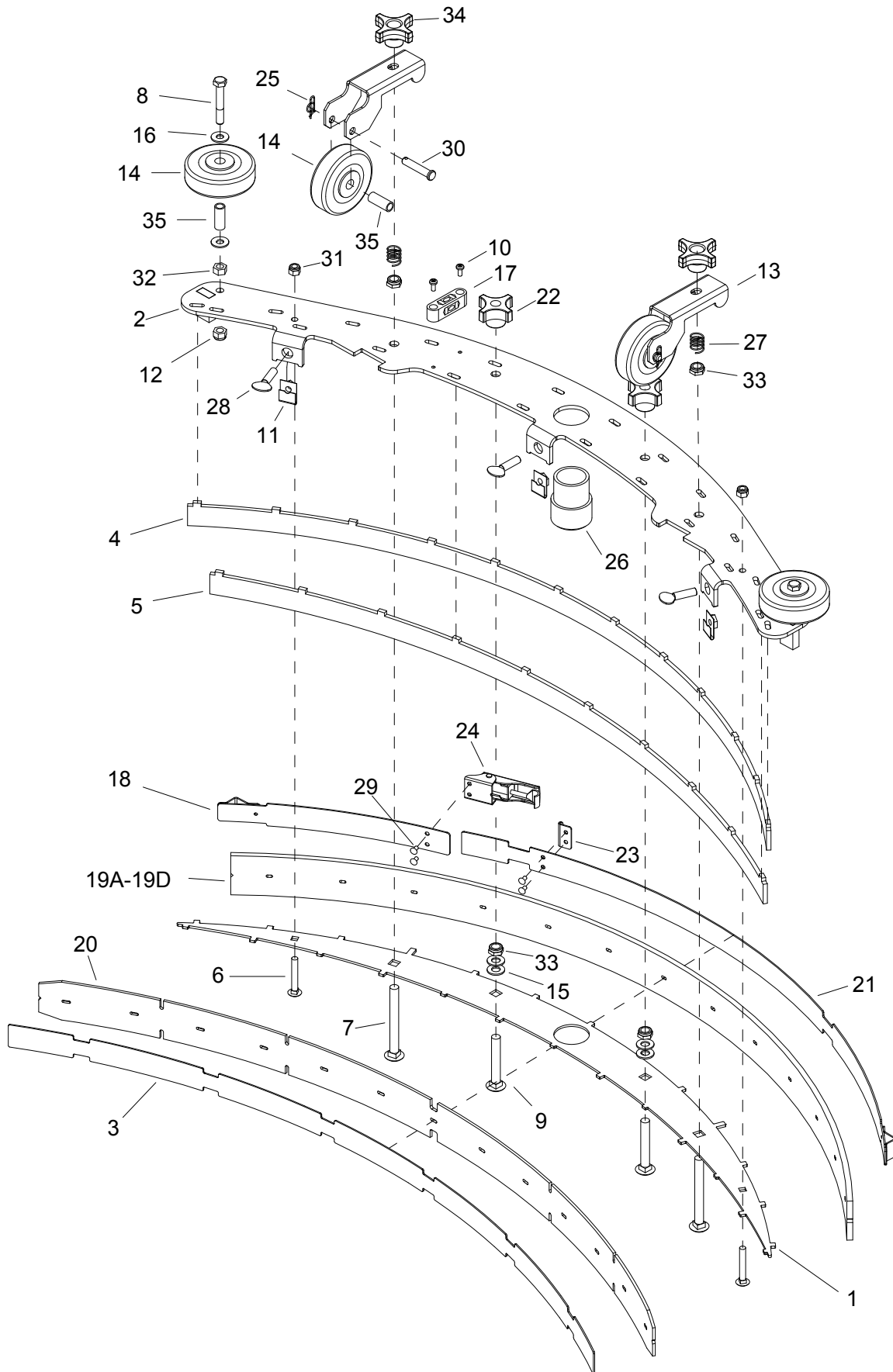

SQUEEGEE-32 IN

REF	PART NO.	QTY	DESCRIPTION	SERIAL NO. FROM	NOTES:
1	86351700	1	PLATE, SQUEEGEE BOTTOM		
2	86351680	1	PLATE ASM, SQUEEGEE TOP 37"		
3	86351630	1	BAND, FRONT SQUEEGEE		
4	86351560	1	PLATE, SQU. VERT. FILL. 32" R		
5	86351550	1	PLATE, SQG. VERT. FILL. 32" F		
6	86277000	2	SCR, 1/4-20 X 1.75 CARRIAGE SS		
7	86276990	2	SCR, 3/8-16 X 3.50 CARRIAGE SS		
8	86276980	2	SCR, 5/16-18 X 2.00 HHCS SS		
9	86276870	2	SCR, 3/8-16 X 2.50 CARRIAGE SS		
10	86274130	2	SCR, 8-32 X 3/8 PHTC 'F' PLTD		
11	86271820	3	NUT, 5/16-18 CAPTIVE "J" PLTD		
12	86270830	2	NUT, 5/16-18 HEX NYLOCK SS		
13	86069870	2	BRKT, SQG WHEEL		
14	86011020	4	WHEEL, 3" DIA. CUSHION RUBBER		
15	86010680	4	WASHER, 3/8 X 3/4 NYL		
16	86010670	4	WASHER, 5/16 X 3/4 SS		
17	86009910	1	VIAL, LEVEL		
18	86009890	1	WELDMENT, REAR SQG BAND SHORT		
19A	86009840	1	SQUEEGEE, REAR BLADE LINATEX		
19B	86009960	REF	SQUEEGEE REAR BLADE BLUE TILE		OPTION
19C	86009980	REF	SQUEEGEE, REAR BLADE BUTTONS		OPTION
19D	86255700	REF	SQUEEGEE BLADE REAR URETHANE 37"		OPTION
20	86009830	1	SQUEEGEE, FRONT BLADE LINATEX		
21	86009820	1	WELDMENT, REAR SQUEEGEE BAND		
22	86009200	2	KNOB, 3/8-16 4 PRONG		
23	86009180	1	STRIKER, SQUEEGEE STRAP REAR		
24	86009170	1	LATCH, SQUEEGEE STRAP		
25	86008660	2	COTTER, 5/16 RING		
26	86008390	1	TUBE, SQUEEGEE VAC		
27	86007780	2	SPRING, COMP .60D X2.0 X.045		
28	86007040	3	SCR, 5/16-18X1 THUMB SS TYPE P		
29	86006400	4	RIVET, 5/32 OD X 1/8 GRIP		
30	86006270	2	PIN, CLEVIS		
31	86005810	2	NUT, 1/4-20 HEX NYLOCK SS		
32	86005650	2	NUT, 5/16-18 HEX		
33	86005630	4	NUT, 3/8-16 HEX NYLOCK THIN SS		
34	86004890	2	KNOB,4 PRONG ALUM 3/8-16 NUT		
35	86001350	4	BUSHING, SPANNER .435 X 1.10		

NOTE: COMPLETE SQUEEGEE ASSEMBLY IS AVAILABLE, PART NO. 86008450, PRV NO. 800615.

SQUEEGEE LIFT

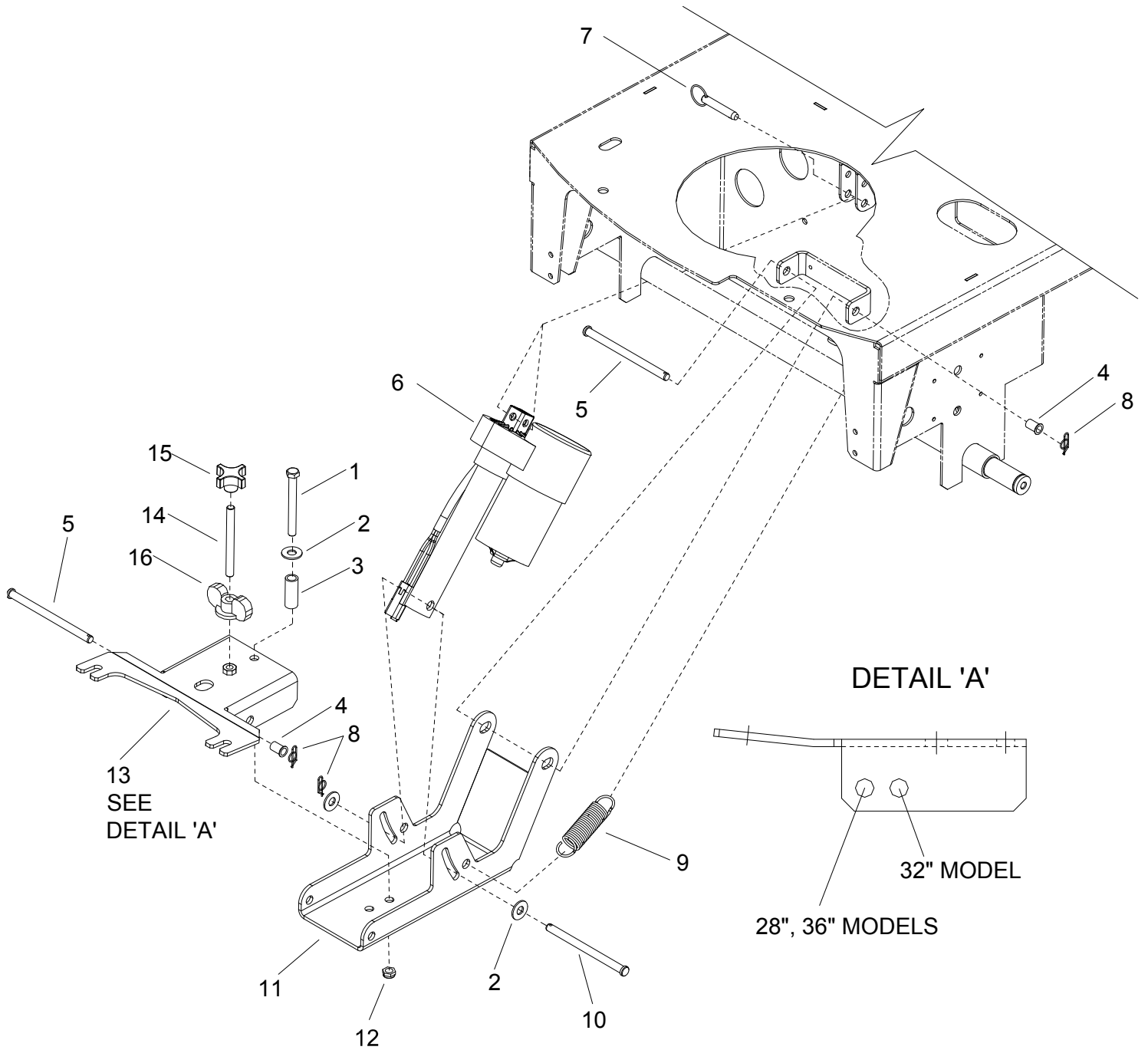

SQUEEGEE LIFT

REF	PART NO.	PRV NO.	QTY	DESCRIPTION	SERIAL NO. FROM	NOTES:
1	86277860	70787	1	SCR, 3/8-16 X 3.75 HHCS SS		
2	86010770	87143	3	WASHER, 7/16ID X 1D X .08 FLT SS		
3	86010160	82830	1	SPRING, .62 X .09 X 1.6 CS ZC GRND		
4	86008870	80815	4	BEARING, FLANGED 3/8" ID 11/16"		
5	86008860	80808	2	PIN, CLEVIS 3/8" X 5.5"L PLTD		
6	86353510	-	1	ACTUATOR 36VDC 2.0 STRK DBLSPD	*(9)	
7	86248910	66369	1	PIN, QUICK RELEASE 0.38 X 1.5		
8	86008670	80606	3	COTTER, 3/8" RING		
9	86255310	73979	2	SPRING, EXT. 1.00OD X 4.0L		
10	86272710	82060	1	PIN, CLEVIS 3/8 X 5.25 PLTD		
11	86091710	140473	1	BRACKET, SQUEEGEE LIFT		
12	86005630	57022	1	NUT, 3/8-16 HEX NYLOCK THIN SS		
13	86009860	82541	1	WELDMENT, SQUEEGEE MOUNT		
14	86088270	730121	1	STUD, 3/8-24 X 4.0 SS		
15	86010050	82696	1	KNOB, 3/8-24 INSERT		
16	86271980	57303	1	NUT, 3/8-24 WING, SS	*(4)	

*SEE SERIAL NUMBER PAGE.

STEERING-UPPER

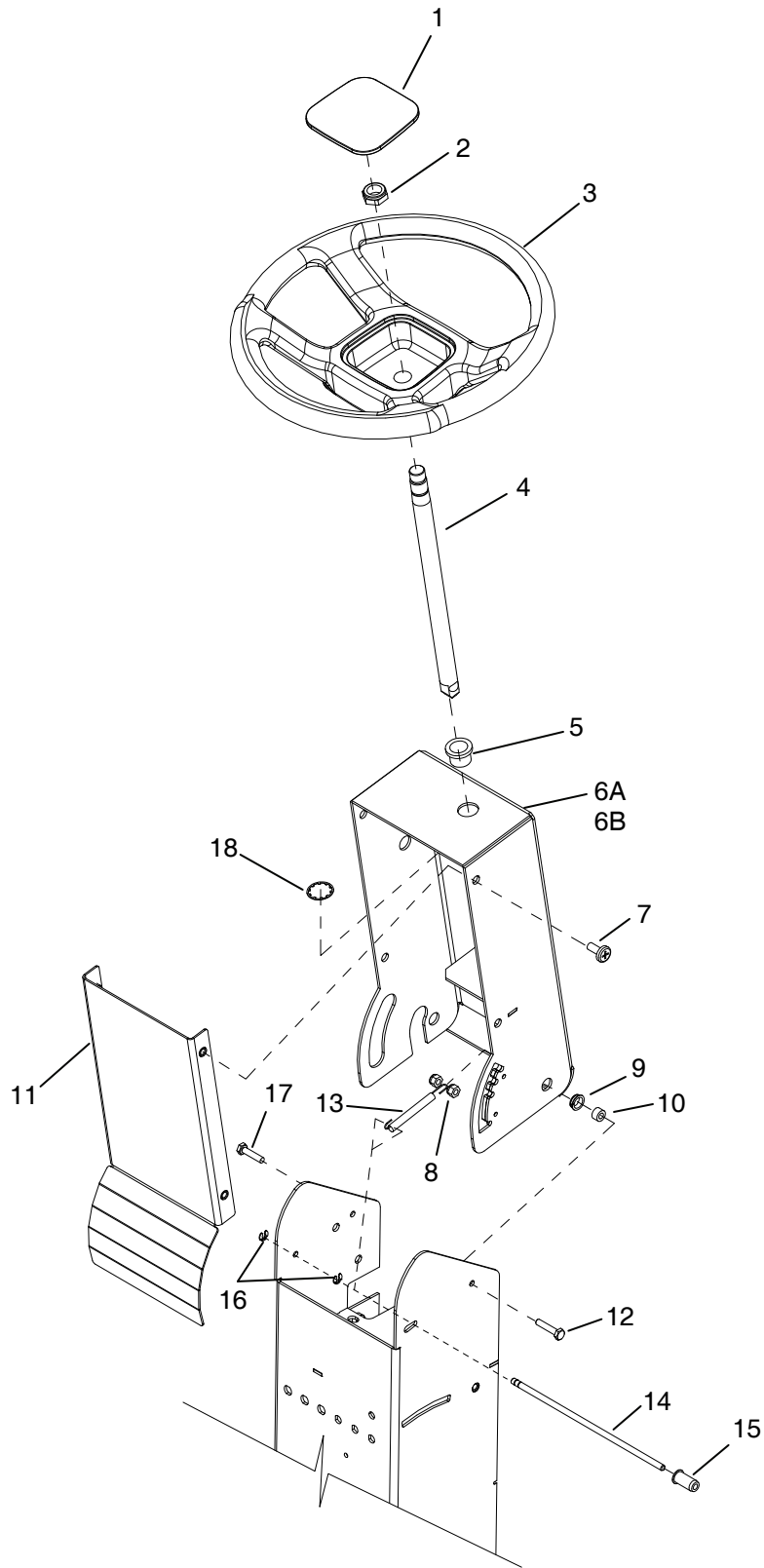

STEERING-UPPER

REF	PART NO.	PRV NO.	QTY	DESCRIPTION	SERIAL NO. FROM	NOTES:
1	86234810	27945	1	COVER, STEERING WHEEL		
2	86271610	57228	1	NUT, 5/8-18 HEX NYLOCK THIN		
3	86259610	730117	1	WHEEL, STEERING 40 SPLINE HUB		
4	86253230	730085	1	SHAFT, UPPER STEERING		
5	86228790	09111	2	BEARING, FLANGE .88OD X .75ID X .75		
6A	86092190	730118	1	COLUMN, UPPER STEERING		28 IN. & 32 IN.
6B	86092200	730160	1	COLUMN, 36 UPPER STEERING		36 IN.
7	86276890	70752	4	SCR, 5/16-8 X 3/4 PTHMS SS		
8	86005810	57245	3	NUT, 1/4-20 HEX NYLOCK SS		
9	86228580	09025	2	BEARING, 1/2 ID CYLINDER		
10	86231260	140486	2	BUSHING, .50D X .26 X .3L SS		
11	86075360	23697	1	COVER, STEERING COLUMN		
12	86273820	70019	1	SCR, 1/4-20 X 1.25 HHCS		
13	86255560	82855	1	SPRING, .31 X .04 X .3.0		
14	86252060	67475	1	ROD, STEERING LOCK		
15	86005620	57021	1	NUT, 1/4-20 X .962 WELL		
16	86006410	67381	2	RING, 1/4 CLIP		
17	86273810	70018	1	SCR, 1/4-20 X 1 HHCS SS		
18	86005610	57016	2	NUT, 7/8 DIA PUSHLOCK		

STEERING- LOWER

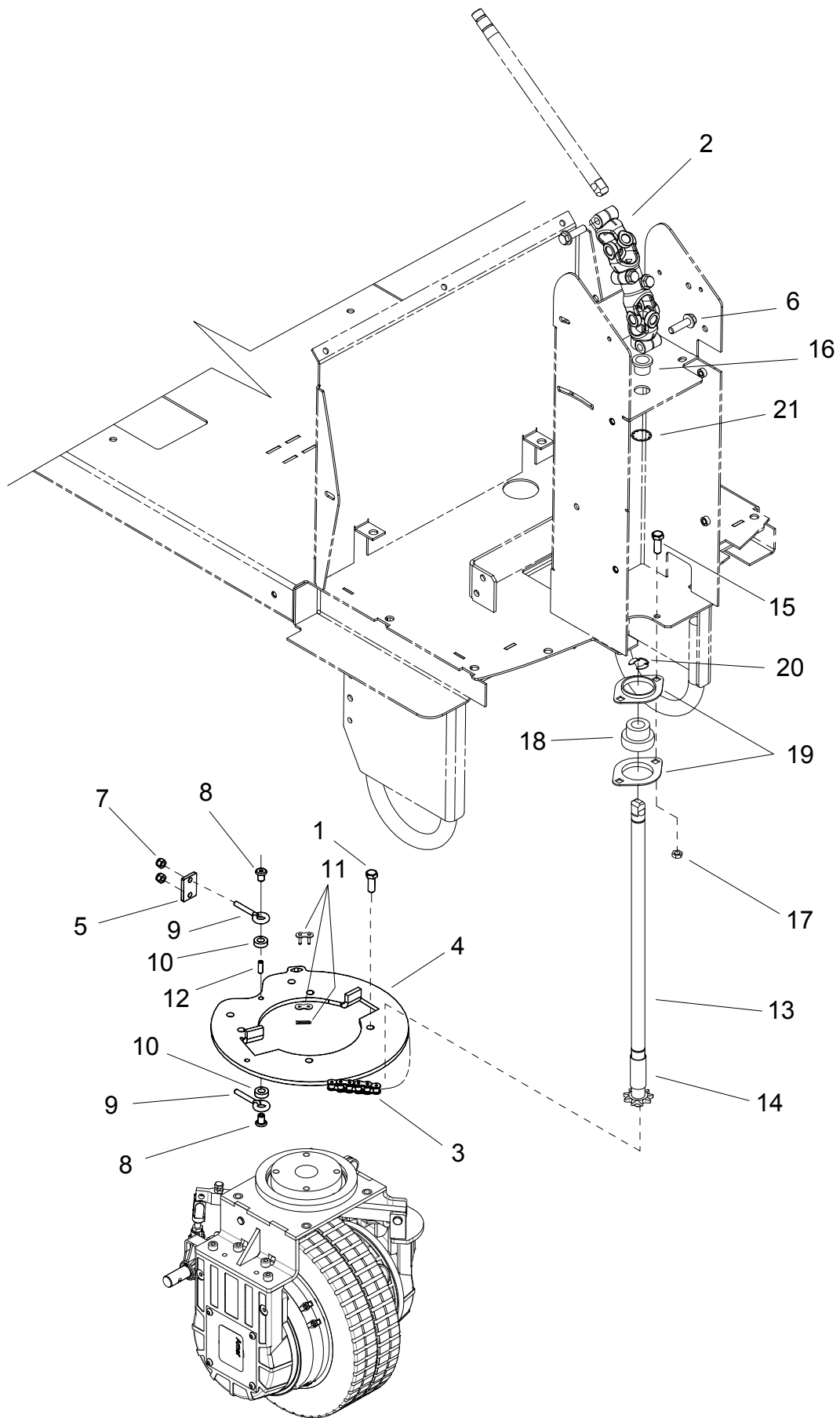

STEERING- LOWER

REF	PART NO.	PRV NO.	QTY	DESCRIPTION	SERIAL NO. FROM	NOTES:
1	86276970	70774	4	SCR, 3/8-16 X 3/4 HHCS SS NP		
2	86258330	45011	1	UNIVERSAL JOINT, DOUBLE		
3	86232800	27946	1	CHAIN, #40-1/2 PITCH X 36		
4	86082310	62951	1	PLATE, STEERING		
5	86082840	66362	1	PLATE, CHAIN TENSIONER		
6	86288410	70762	4	SCR, M10-1.5 X 35MM HHFS		
7	86005810	57245	2	NUT, 1/4-20 HEX NYLOCK SS		
8	86005860	57273	2	NUT, 1/4-20 X 12MM HEX BARREL		
9	86270310	70760	2	EYEBOLT, 1/4-20 X 1.5 PLTD		
10	86264490	73440	2	SPACER, .75OD X .39ID X .25 HDPE		
11	86002850	27343	2	CHAIN, #40-1/2" P MASTER LINK		
12	86278070	70761	1	SET SCREW, 1/4-20 X 3/4 SS		
13	86094330	730116	1	STEERING ASM, LOWER SHAFT		
14	86087260	730132	1	SPACER, 7/8 OD X .049W X 1.75L		
15	86276780	70728	2	SCR, 5/16-18 X 3/4 HHCS SS		
16	86228790	09111	1	BEARING, FLANGE .88OD X .75ID X.75		
17	86270830	57023	2	NUT, 5/16-18 HEX NYLOCK SS		
18	86001030	09148	1	BEARING, BALL 3/4 BORE SPHERED		
19	86008610	80595	2	FLANGE, BEARING PRESS STEEL		
20	86272900	67416	1	RING, 3/4" CLIP		
21	86005610	57016	1	NUT, 7/8 DIA PUSHLOCK		

TANK

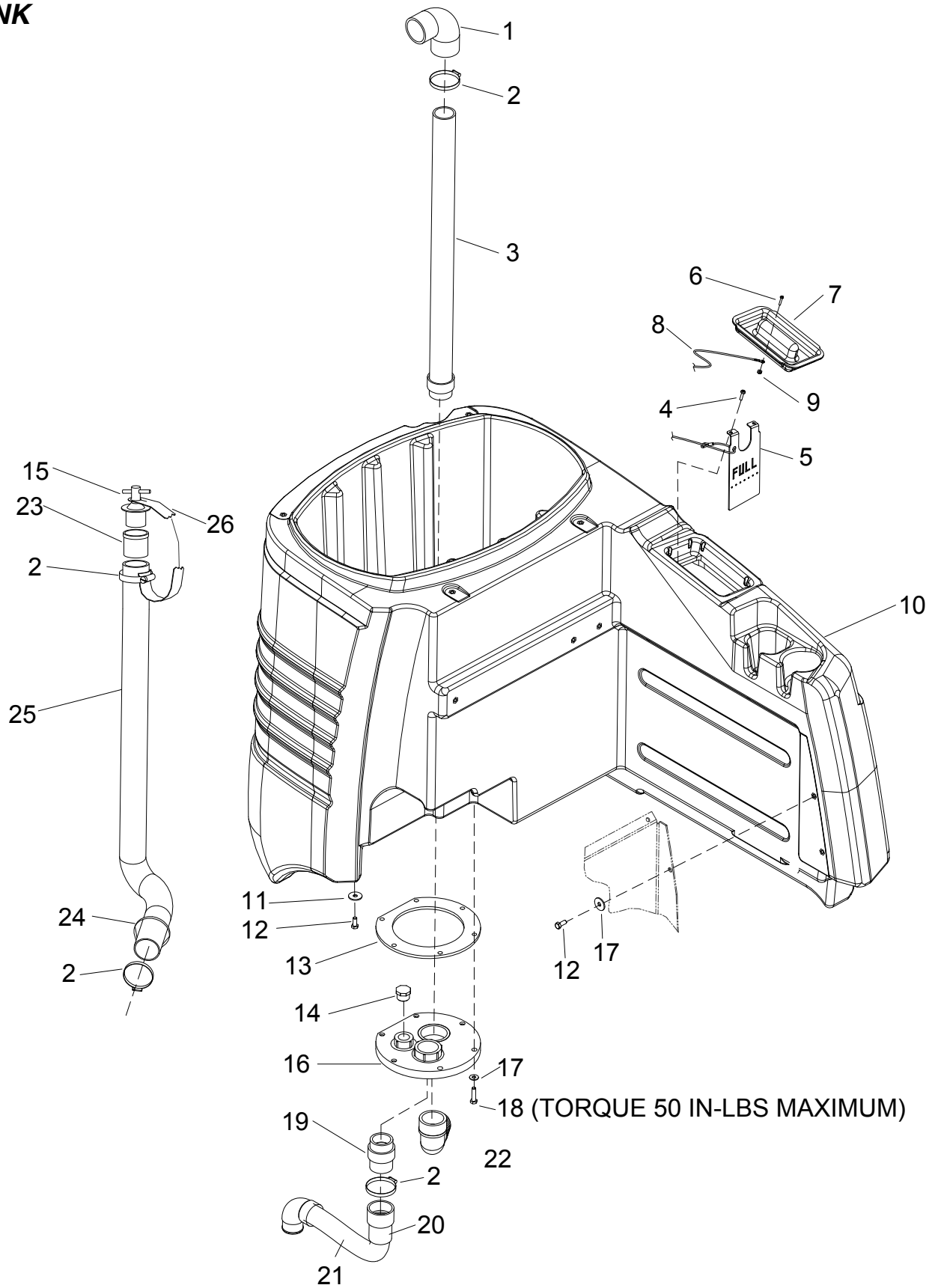

TANK

REF	PART NO.	PRV NO.	QTY	DESCRIPTION	SERIAL NO. FROM	NOTES:
1	86235580	81220	1	ELBOW, 90° RUBBER		
2	86233430	81431	4	CLAMP, 2.50 WORM GEAR		
3	86033270	78482	1	TUBE ASM, SQUEEGEE VAC		
4	86276600	70696	2	SCR, #10 X 3/4 PTHSMS SS		
5	86066310	140535	1	BAFFLE, SMALL RIDER		
6	86273950	70056	1	SCR, 6-32 X 1/2 PPHMS		
7	86234790	27827	1	COVER, CLP SOLUTION		
8	86246080	51368	1	LANYARD, 18.0 W/ LOOP & EYE		
9	86270920	57049	1	NUT, 6-32 HEX NYLOCK SS		
10	86032570	75374	1	TANK, SMALL RIDER		
11	86279630	87212	2	WASHER, .344ID X 1.13OD X .09T PLTD		
12	86276780	70728	4	SCR, 5/16-18 X 3/4 HHCS SS		
13	86237790	35260	1	GASKET, TANK PLATE		
14	86006260	66240	1	PLUG, 3/4" MPT PVC		
15	86006340	66347	1	PLUG, 1-3/4 DRAIN HOSE		
16	86033140	62930	1	PLATE ASM, TANK FITTING		
17	86010670	87029	8	WASHER, 5/16 FLAT SS		
18	86007020	70673	6	SCR, 5/16-18 X 1.25 HHCS SS		
19	86033290	78500	1	TUBE ASM, SQUEEGEE		
20	86234900	27508	1	CUFF, VAC HOSE BLACK		
21	86004420	39609	1	HOSE ASM, 1.5 BLK VAC X 14		
22	86240450	40085	1	HOSEBARB, 90° 2 NPT X 2		
23	86076830	40086	1	HOSEBARB, 2.0		
24	86002830	27196	1	CABLE TIE, .375 X 24.7		
25	86004410	39594	1	HOSE, 2 X 33.5" DRAIN		
26	86008400	78499	1	TETHER, 2 IN DRAIN PLUG		

TANK COVER

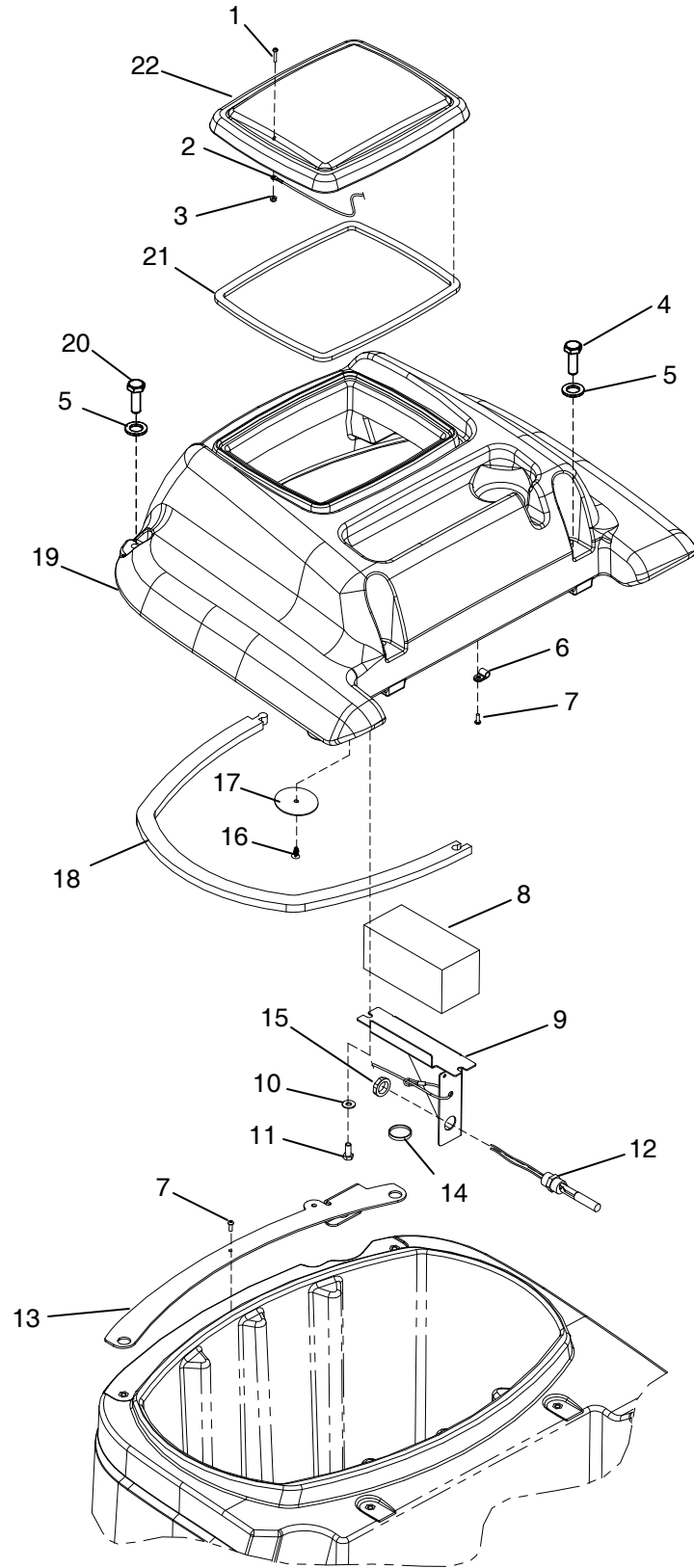

TANK COVER

REF	PART NO.	PRV NO.	QTY	DESCRIPTION	SERIAL NO. FROM	NOTES:
1	86273950	70056	1	SCR, 6-32 X 1/2 PPHMS		
2	86246080	51368	1	LANYARD, 18.0 W/ LOOP & EYE		
3	86270920	57049	1	NUT, 6-32 HEX NYLOCK SS		
4	86276910	70754	2	SCR, 5/16-18 X 3 HHCS SS NP		
5	86279630	87212	4	WASHER, .344ID X 1.13OD X .09T PLTD		
6	86198450	20005	4	CLAMP, 5/16 NYLON		
7	86006500	70024	5	SCR, #8 X 1/2 SHT METAL SS		
8	86003690	34390	1	FILTER, VAC		
9	86069740	140505	1	BRACKET, RECOVERY FILTER		
10	86010670	87029	2	WASHER, 5/16 FLAT SS		
11	86277040	70781	2	SCR, 5/16-18 X 1/2 HHCS SS		
12	86007460	730122	1	SWITCH ASM, FLOAT		
13	86082360	62956	1	PLATE, HOSE MOUNT		
14	86264930	27050	1	CABLE TIE, 3.5" UL/CSA		
15	86271850	57287	1	NUT, 1/2 NPT PLASTIC		
16	86233560	80805	1	CLIP, TREE .19 HOLE FLAT HEAD		
17	86258670	81473	1	VALVE, DISK DRAIN		
18	86238010	36217	2	GASKET, 1/2T X 1.0W X 36.88L		
19	86031830	27935	1	COVER, TANK SMALL RIDER		
20	86276790	70732	2	SCR, 5/16-18 X 1.75 HHCS SS		
21	86004010	35274	1	GASKET, DOME	*(5)	
22	86003340	28062	1	DOME, 13 X 11		

*SEE SERIAL NUMBER PAGE.

VACUUM GROUP

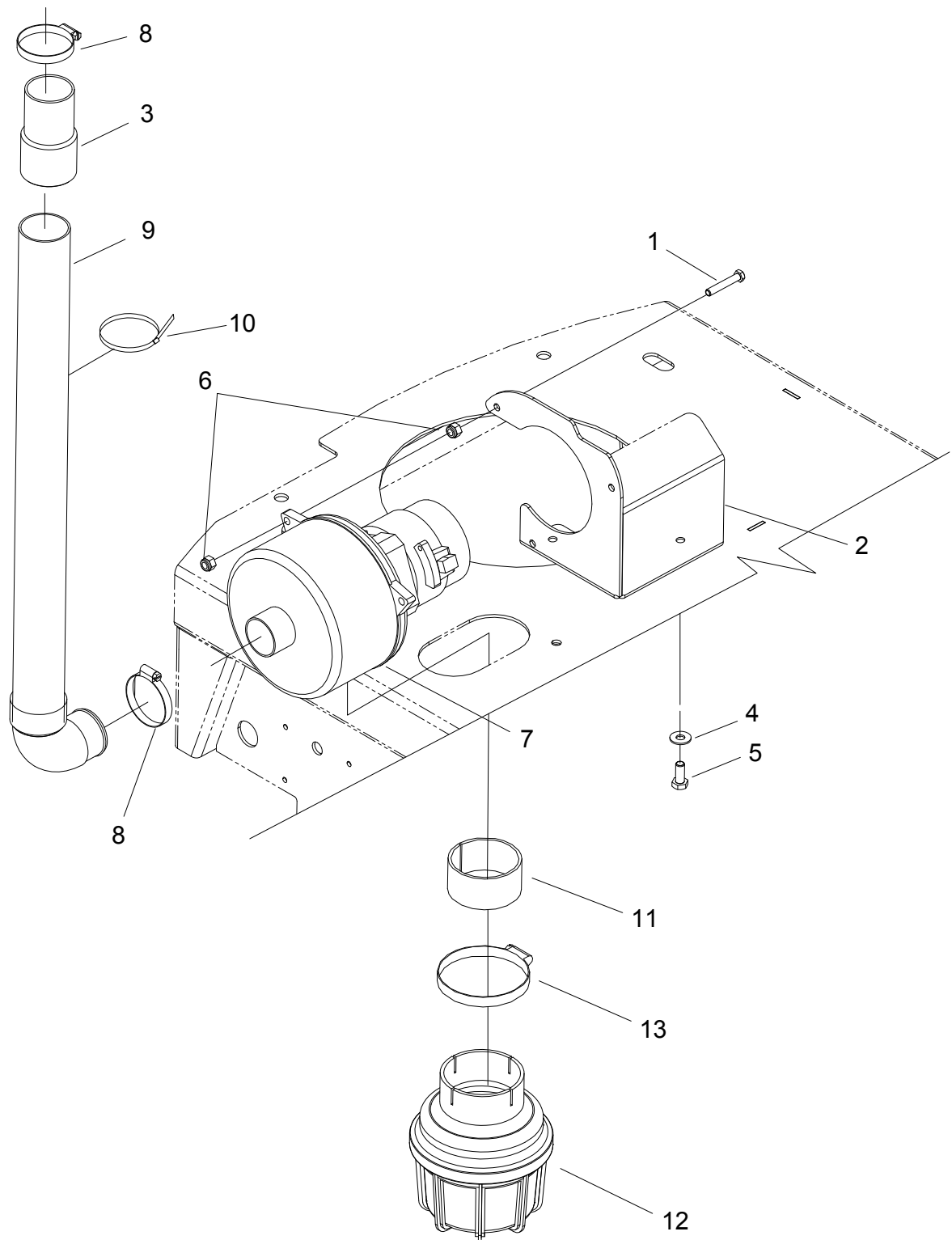

VACUUM GROUP

REF	PART NO.	PRV NO.	QTY	DESCRIPTION	SERIAL NO. FROM	NOTES:
1	86274800	70297	3	SCR, 1/4-20 X 1.5 HHMS		
2	86069560	140476	1	BRACKET, VACUUM MOUNTING		
3	86003010	27759	1	CUFF, HOSE 1.5" BLK A2161		
4	86279130	87083	2	WASHER, 5/16 SPLIT LOCK PLTD		
5	86276780	70728	2	SCR, 5/16-18 X 3/4 HHCS SS		
6	86005810	57245	6	NUT, 1/4-20 HEX NYLOCK SS		
7	86005450	53799	1	VAC MOTOR ASM, 36VDC 3 STAGE		
-	86230800	140550	1	BRUSH SET, VAC MOTOR AMETEK		SERVICE ONLY
-	86135310	140686	1	BRUSH SET, VAC 24V/36V WINDSOR		SERVICE ONLY
8	86233140	20041	2	CLAMP, 2.0" WORM GEAR		
9	86240170	39614	1	HOSE ASM, 1.5 BLK VAC X 19		
10	86264920	27049	3	CABLE TIE, 7" UL/CSA		
11	86091170	730174	1	TUBE, 2.0 OD X .05 W X 1.0 L		
12	86233430	81431	1	CLAMP, 2.50 WORM GEAR		
13	86064910	54194	1	MUFFLER, VAC MOTOR		

WHEELS & FRAME

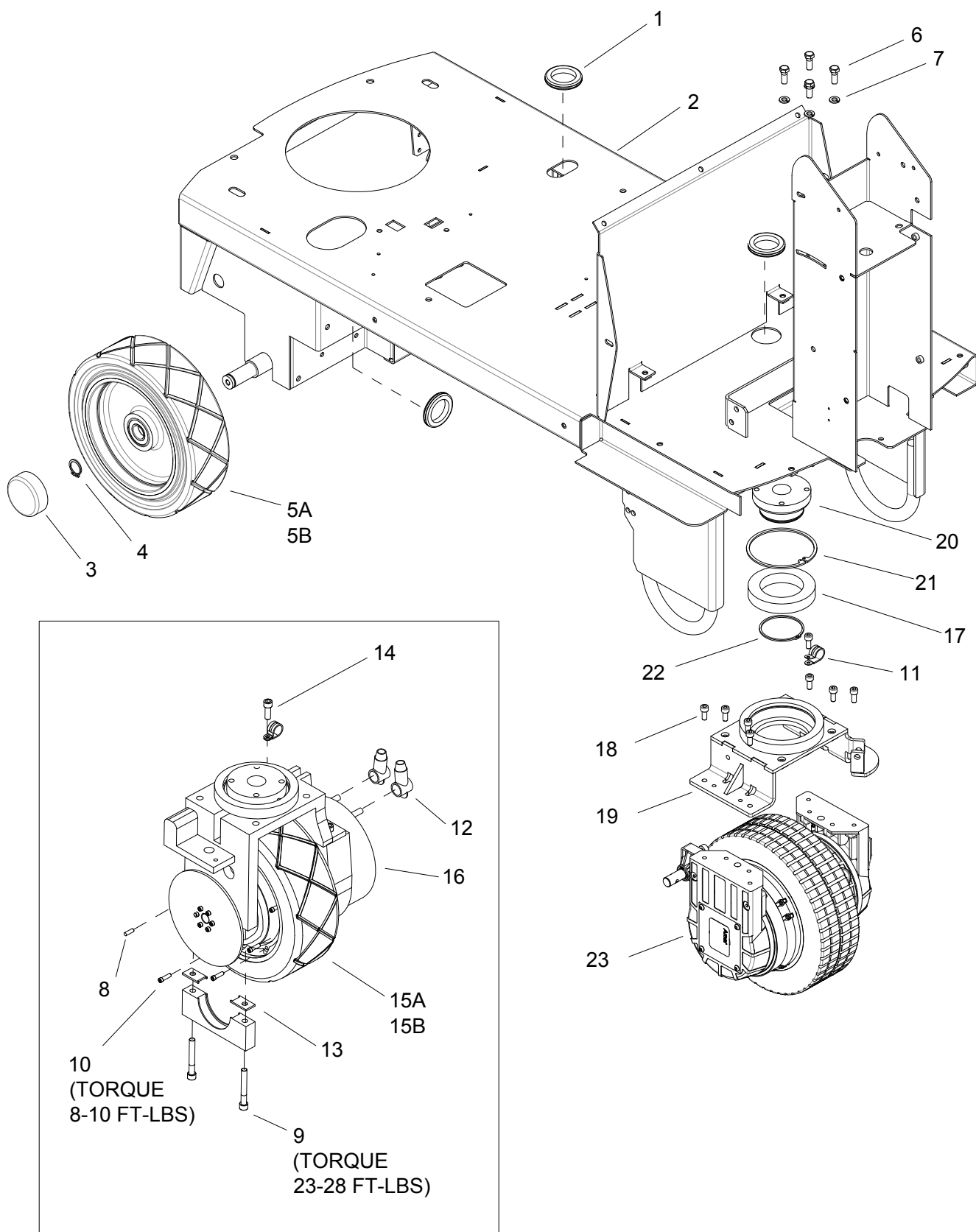

WHEELS & FRAME

REF	PART NO.	PRV NO.	QTY	DESCRIPTION	SERIAL NO. FROM	NOTES:
1	86238500	81427	3	GROMMET, 1.703ID X 2.50D X .125 GRY		
2	86092430	34385	1	FRAME, RIDER SCRUBBER		
3	86232130	17309	2	CAP, 2.75 ID X 1.0 L BLK VINYL		
4	86272910	67471	2	RING, 63/64 EXTERNAL SNAP		
5A	86011090	89224	2	WHEEL ASM, 12 X 3.5 X 8 SCRUBBER COMPOUND		
5B	86259890	89230	2	WHEEL ASM, 12 X 3.5 X 8 GRAY		OPTION
6	86276920	70755	4	SCR, 3/8-16 X 1 HHCS SS NP		
7	86010790	87163	4	WASHER, 3/8 SPLIT LOCK		
8	86317210	-	2	PIN, DOWEL M8-1.25 X 24		
9	86173150	70946	2	SCR, 3/8-16 X 2.5 SHCS BLK		
10	86277250	70818	8	SCR, M6 X 25MM HSNCS NP		
11	86233410	81270	1	CLAMP, 3/4 DIA. CUSHION .406 DIA.		
12	86008920	80889	2	BOOT, RUBBER TERM. ISOLATER		
13	86087380	730419	2	SPACER, CLAMP	*(6)	
14	86274120	70096	4	SCR 3/8-16 X 1.0 SHCS BLK		
15A	86259880	89225	1	WHEEL, 12 X 4 X 8 SCRUB COMPOUND		
15B	86259900	89253	1	WHEEL, 12 X 4 X 8 GRAY		OPTION
16	86003450	29256	1	MOTOR ASM, 36V DRV. WHEEL		
-	86001460	140552	REF	BRUSH SET, MOTOR		SERVICE ONLY
-	86215180	09142	REF	BEARING, STEERING		SERVICE ONLY
-	86004760	47417	REF	KIT, ARMATURE ASM FOR 29256		SERVICE ONLY
-	86222190	54188	REF	MOTOR & GEARBOX FOR 29256		SERVICE ONLY
-	86217990	34403	REF	FRAME, STEERING MOUNT ASM (29256)		SERVICE ONLY
-	86215190	09143	REF	BEARING, 60ID X 95OD		SERVICE ONLY
17	86215180	09142	1	BEARING 75ID X 115OD	*(8)	
18	86274650	70254	8	SCR, M8 X 18 SHCS PLTD	*(8)	
19	86358720	-	1	BRKT ASM, DRIVE MOUNT	*(8)	
20	86358910	-	1	COUPLING, FRONT WHEEL	*(8)	
21	86358920	-	1	RING, 4-1/2" INTERNAL SNAP	*(8)	
22	86358930	-	1	RING, 3" EXTERNAL SNAP	*(8)	
23	86358950	-	1	MOTOR ASM, 36V DRIVE	*(8)	

*SEE SERIAL NUMBER PAGE.

**CALL MANUFACTURER FOR SERIAL NUMBER.

WHEEL MOTOR -SERVICE PARTS

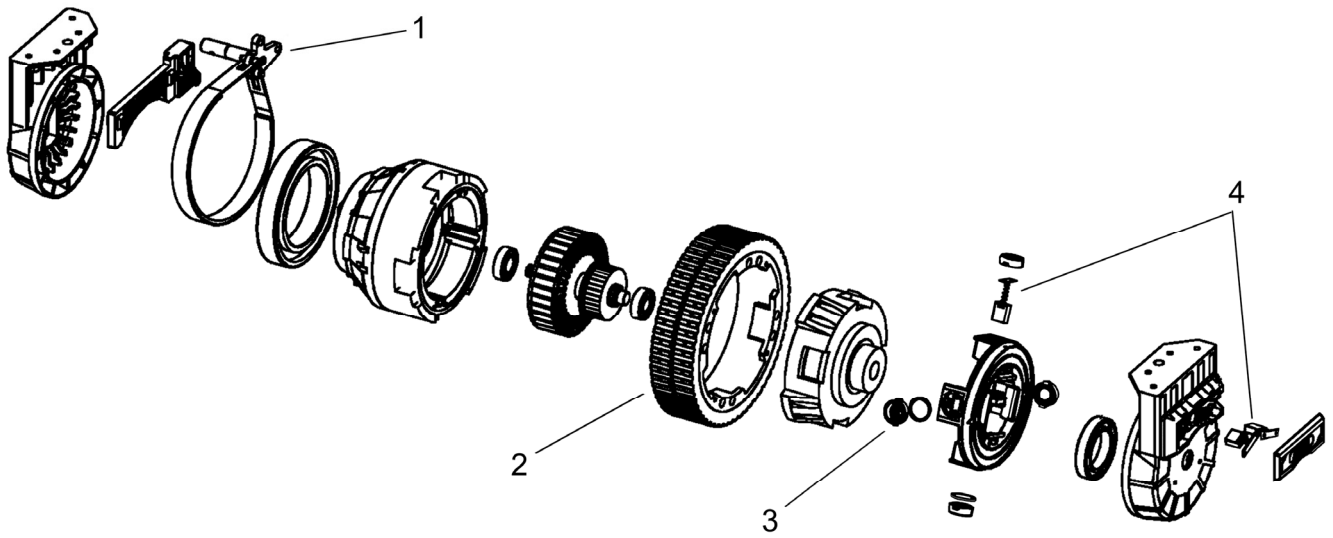

WHEEL MOTOR-SERVICE PARTS

REF	PART NO.	PRV NO.	QTY	DESCRIPTION	SERIAL NO. FROM	NOTES:
1	86366970	-	1	BAND BRAKE KIT	*(8)	
2	86366960	-	1	WHEEL, RED POLY 300 X 90	*(8)	
3	86366980	-	1	BRUSH CAP AND O-RING KIT	*(8)	
4	86366950	-	1	BRUSH KIT	*(8)	

*SEE SERIAL NUMBER PAGE.

WIRING-BATTERY

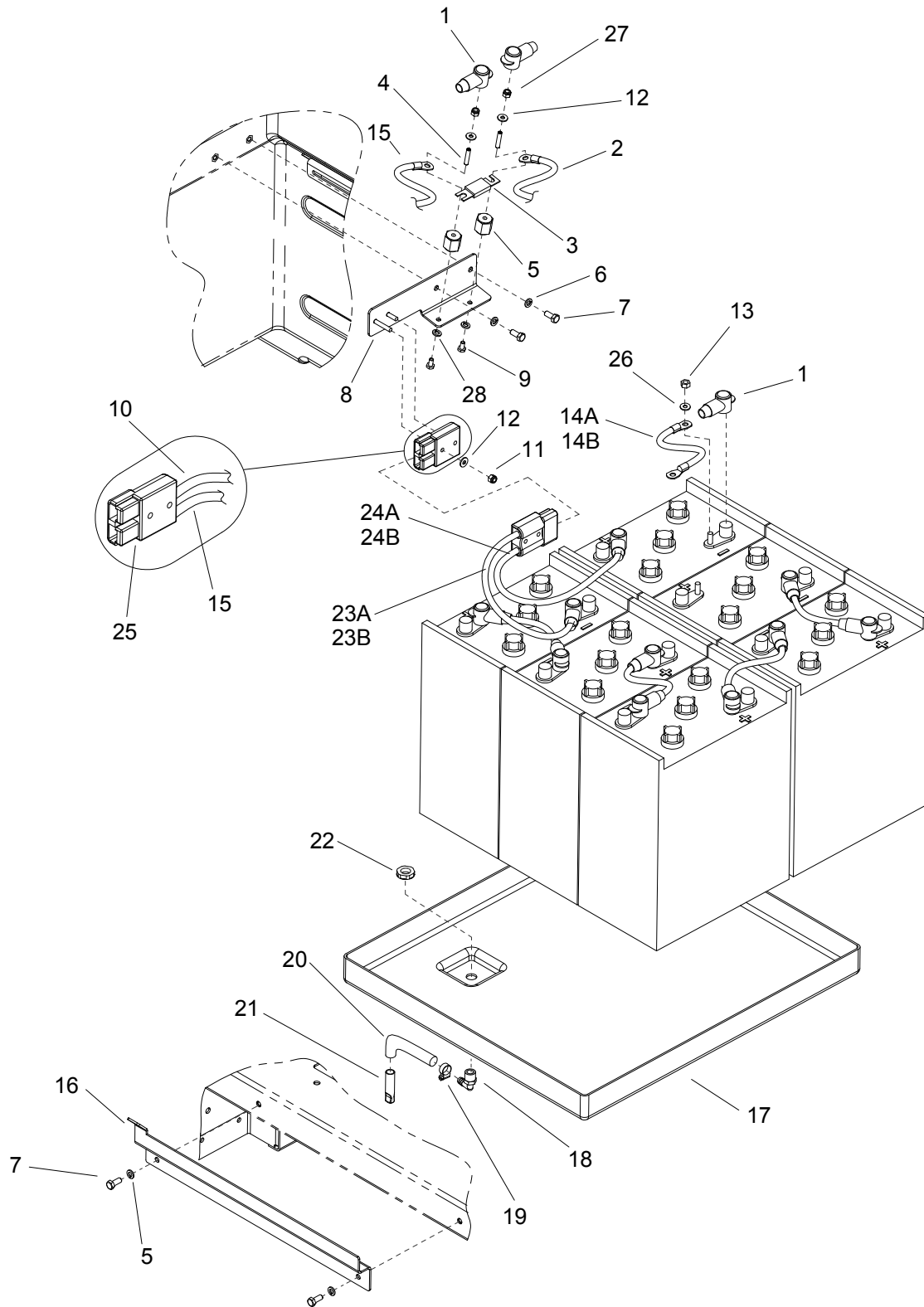

WIRING-BATTERY

REF	PART NO.	PRV NO.	QTY	DESCRIPTION	SERIAL NO. FROM	NOTES:
1	86008920	80889	14	BOOT, RUBBER TERM. ISOLATOR		
2	86232040	830957	1	CABLE, 4GA BLACK X 78.5"		
3	86008790	80687	1	FUSE, 125 AMP		
4	86006850	70393	2	SET SCR, 1/4-20 X 1.25L		
5	86255910	73659	2	STANDOFF, 1/4-20 X 1.0 HEX INS		
6	86279130	87083	4	WASHER, 5/16 SPLIT LOCK PLTD		
7	86276780	70728	4	SCR, 5/16-18 X 3/4 HHCS SS		
8	86069720	140497	1	BRACKET, BATTERY CONNECTOR		
9	86273830	70020	2	SCR, 1/4-20 X 1/2 HHCS SS		
10	86260310	82687	1	WIRE, 4 X 77BK C. TERM X 5/16 RING		
11	86005810	57245	1	NUT, 1/4-20 HEX NYLOCK SS		
12	86010630	87013	3	WASHER, 1/4ID X 5/8OD SS		
13	86271910	57295	12	NUT, 5/16-18 FLEXLOCK		
14A	86009000	81131	5	WIRE, 4X9.5BK 5/16RINGX5/16RING		
14B	86002510	23125	5	CABLE ASM, BAT. JUMPER X 15"		
15	86260510	880377	1	WIRE, 4 X 6 BK C.TERM X 5/16 RING		
16	86069690	140493	1	BRACKET, BATTERY		
17	86395350	-	1	TRAY, BATTERY GLIDE		
18	86001550	40043	1	HOSEBARB, 3/8 MPT X 3/8 90D		
19	86233090	20016	1	CLAMP, 1/4ID HOSE		
20	86281820	39509	1	HOSE, 3/8 VINYL X 16"		
21	86002030	17298	1	CAP, .460ID X 1.5L BLK VINYL		
22	86271830	57283	1	NUT, 3/8 NPT PLASTIC		
23A	86010860	880353	1	WIRE, 4X20 BK CTERM X5/16RING		
23B	86002580	23191	1	CABLE, 4 X 27 BK C TERM X B CLAMP		
24A	86010850	880352	1	WIRE, 4X20RD CTERM X 5/16RING		
24B	86002570	23190	1	CABLE, 4 X 27 RD C. TERM X B CLAMP		
25	86008760	80682	2	CONNECTOR, BATTERY GRY 175 AMP		
26	86010670	87029	12	WASHER, 5/16 FLAT SS		
27	86005710	57105	2	NUT, 1/4-20 HEX W/ STAR WASHER		
28	86010780	87162	2	WASHER, 1/4 SPLIT LOCK		
29	86233360	28038	1	CLAMP, CABLE KIT SY945		
30	86270890	57034	1	NUT, ACORN 10-32		
31	86010650	87018	1	WASHER, #10 X 9/16 OD		
32	86273980	70066	1	SCREW, 10-32 X 3/4 PPHMS SS		
33	86312710	-	2	BLOCK, 3.5 X 4 X 5		FOR 86312720 BATTERIES

WIRING GROUP-MAIN HARNESS

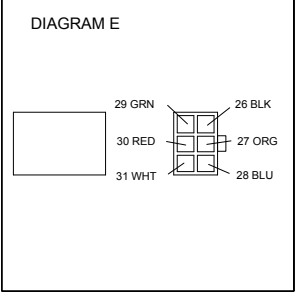
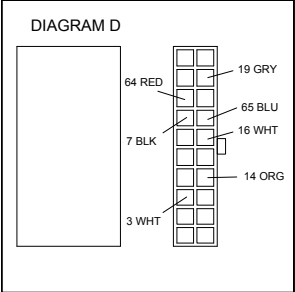
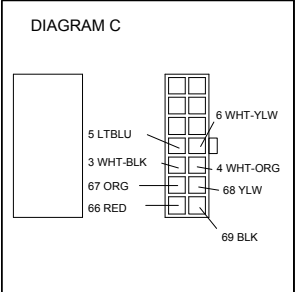
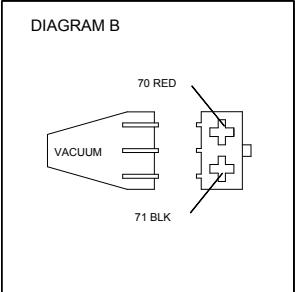
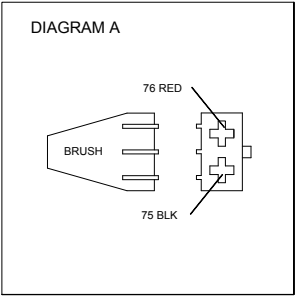
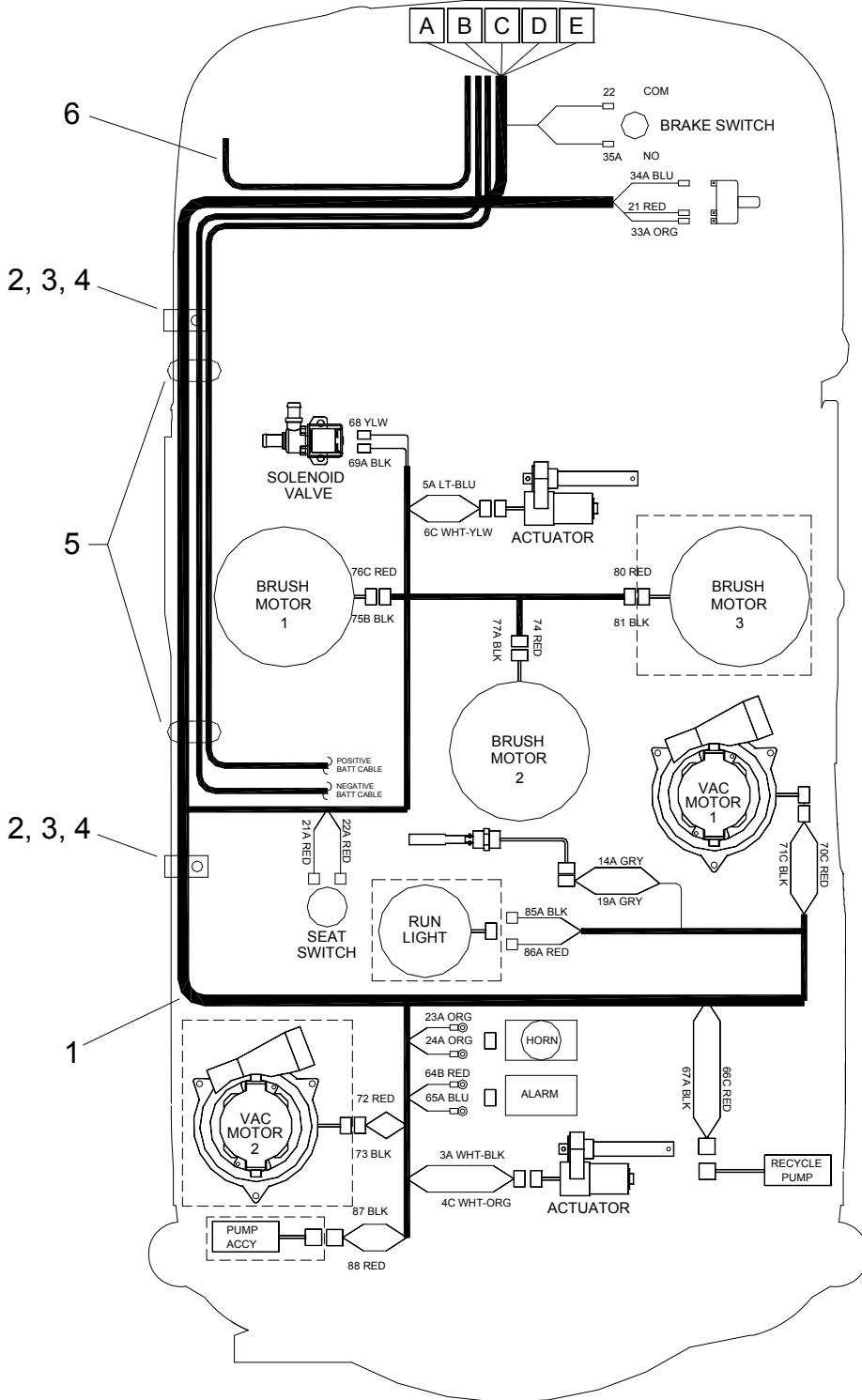

INDICATES OPTIONAL ACCESSORY

WIRING GROUP - MAIN HARNESS

REF	PART NO.	PRV NO.	QTY	DESCRIPTION	SERIAL NO. FROM	NOTES:
1	86239500	880421	1	HARNESS, SRS UPPER		
2	86233390	80887	2	CLAMP, 7/8 DIA "P" CUSHIONED		
3	86273780	70015	2	SCR, 1/4-20 X 3/4 HHCS SS		
4	86005810	57245	2	NUT, 1/4-20 HEX NYLOCK SS		
5	86264920	27049	2	CABLE TIE, 7" UL/CSA		
6	86239510	880422	REF	LCD HARNESS		

WIRING GROUP - MAIN HARNESS CONNECTION

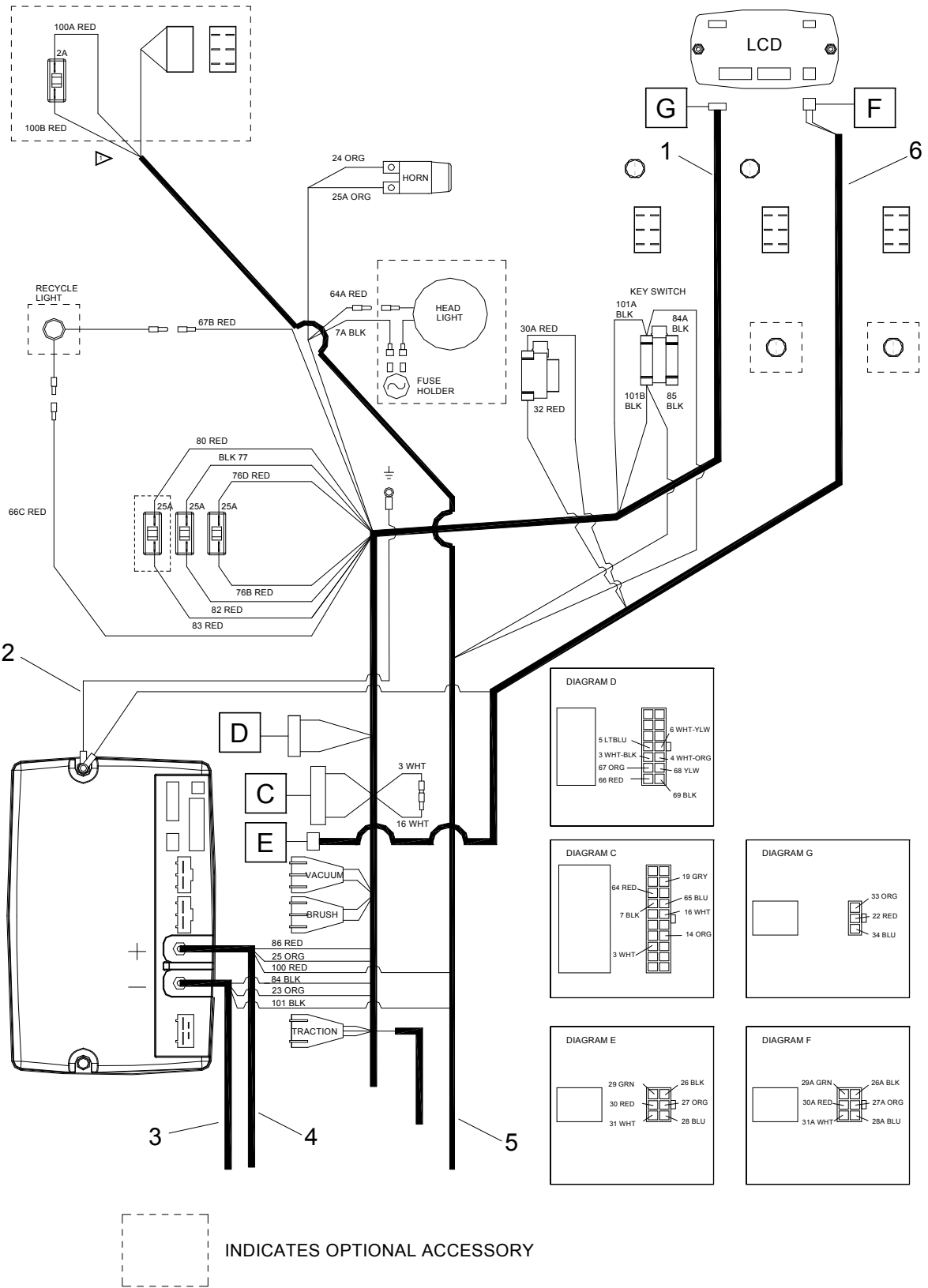

WIRING GROUP-MAIN HARNESS CONNECTION

REF	PART NO.	PRV NO.	QTY	DESCRIPTION	SERIAL NO. FROM	NOTES:
1	86239500	880421	REF	HARNESS SRS UPPER		
2	86267290	880262	1	WIRE, 14" GRN/18 76008 X 76011		
3	86260310	82687	REF	WIRE, 4 X 77BK C. TERM X 5/16 RING		
4	86232040	830957	REF	CABLE, 4GA BLACK X 78.5"		
5	86239010	41462	1	HARNESS, DECK SHIFT		36 IN ONLY
6	86239510	880422	1	LCD HARNESS		

NOTE: Maximum speed of machine can be decreased to 80% of maximum by disconnecting wire 3 white from wire 16 white. Machine is set at 100% speed setting at factory.

WIRING GROUP-CONTROL PANEL GROUP

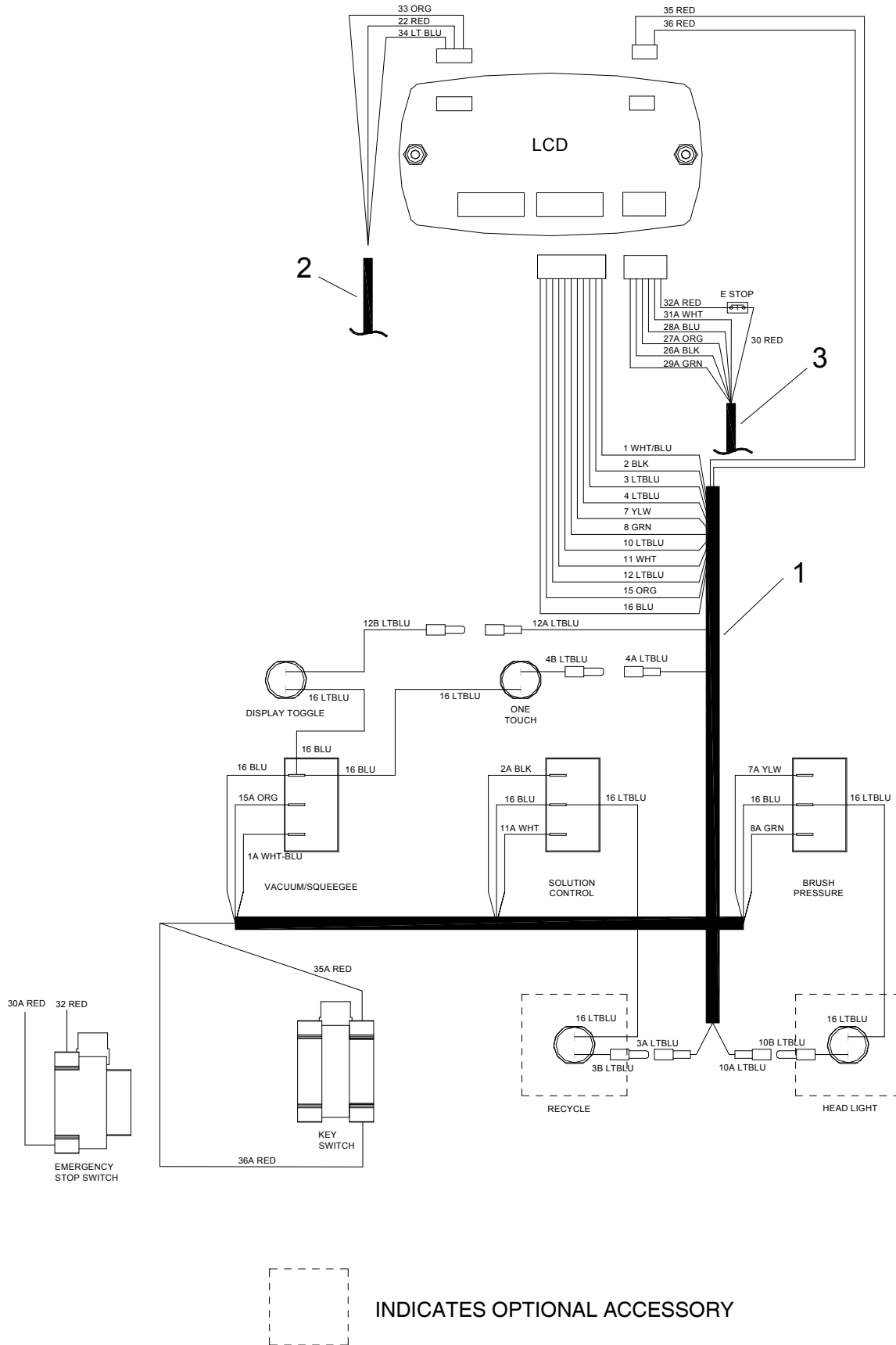

WIRING GROUP-CONTROL PANEL

REF	PART NO.	PRV NO.	QTY	DESCRIPTION	SERIAL NO. FROM	NOTES:
1	86239490	880378	1	HARNESS, CONTROL		
2	86239500	880421	REF	HARNESS, GLIDE TRIO +		
3	86239510	880422	REF	HARNESS, GLIDE LCD		

WIRING-DRIVE MOTOR

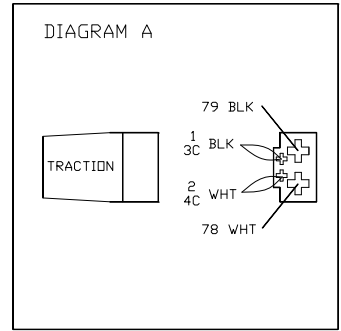
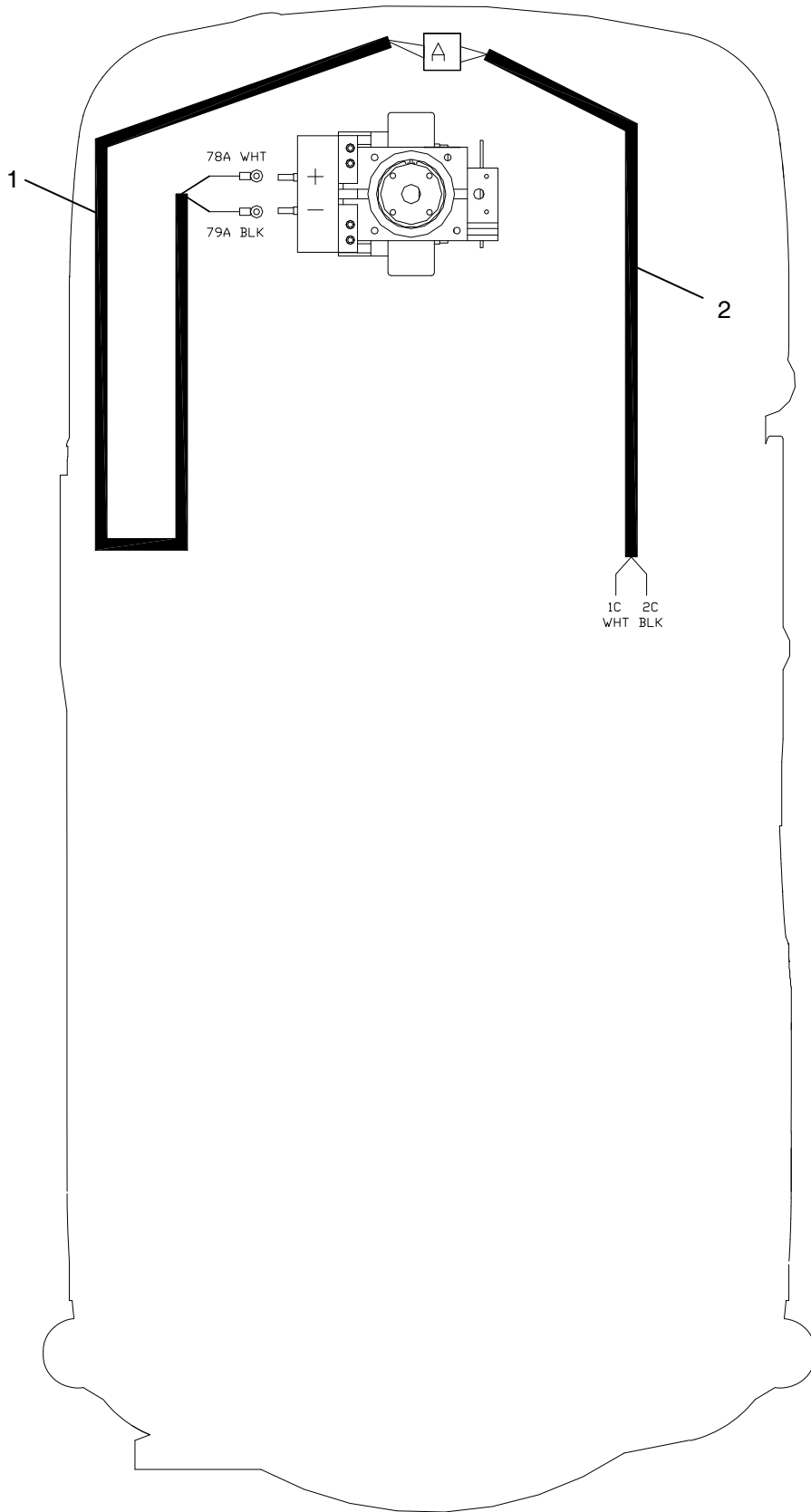

WIRING -DRIVE MOTOR

REF	PART NO.	PRV NO.	QTY	DESCRIPTION	SERIAL NO. FROM	NOTES:
1	86010870	880379	1	HARNESS, PROPEL		
2	86261660	880424	1	WIRE HARNESS, FCM GLIDE		SGEO28, SGEO32 ONLY

WIRING DIAGRAM

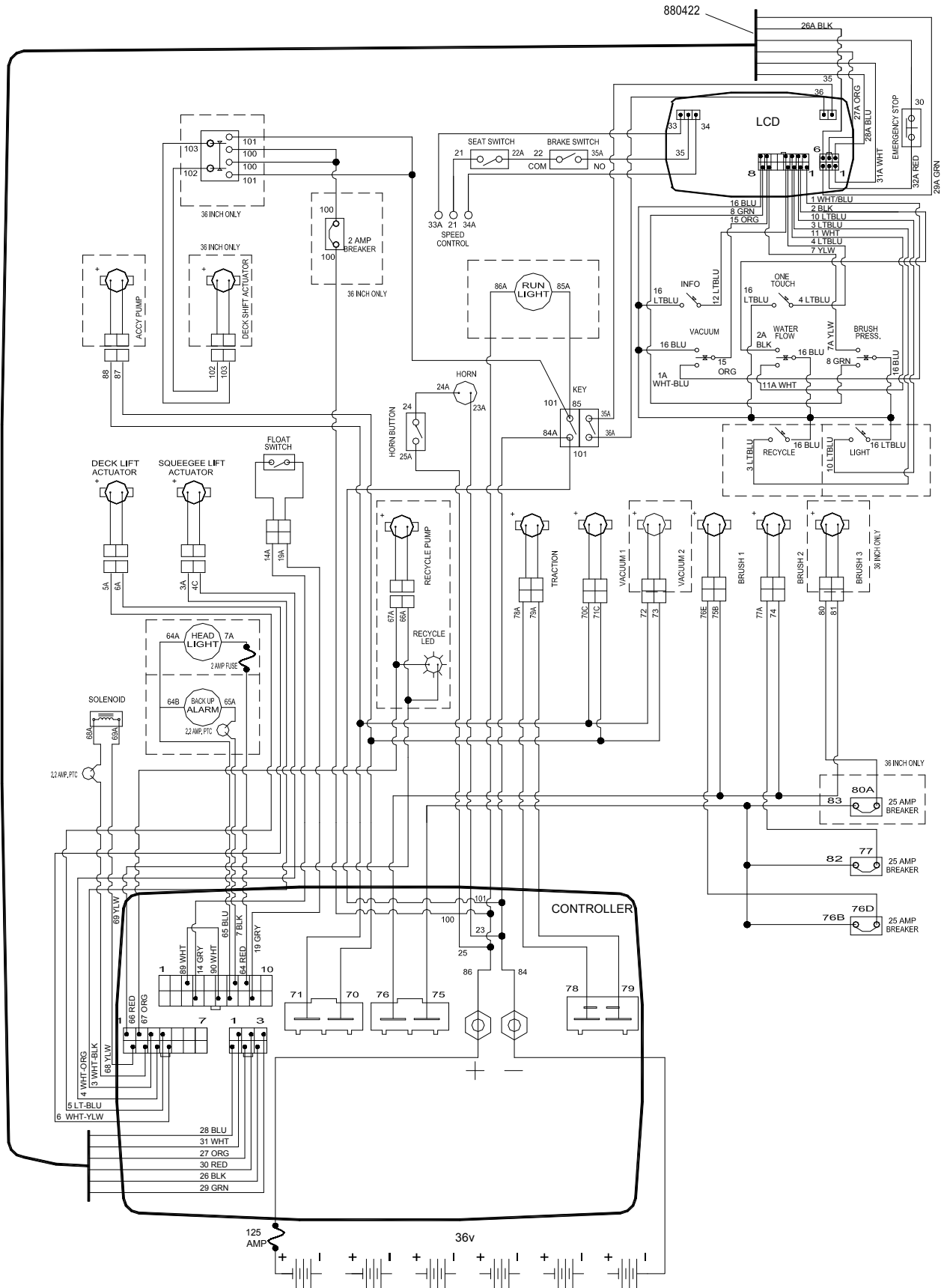

SUGGESTED SPARE PARTS

PART NO.	PRV NO.	DESCRIPTION	SERIAL NO. FROM	NOTES:
86008790	80687	FUSE, 125 AMP		
86001870	14415	BLADE, SQUEEGEE FRONT		
86001440	140533	BLADE. SQUEEGEE REAR		
86003690	34390	FILTER, VAC		
86007420	730100	SQUEEGEE, SIDE BLADE LINATEX		28 IN. & 32 IN.
86007580	730167	SQUEEGEE, 32 SIDE BLADE		32 IN.
86007390	730093	SQUEEGEE, SIDE BLADE LINATEX		36 IN.
86007550	730154	SQUEEGEE BLADE, SECONDARY		36 IN.
86004860	48073	KEY, SWITCH		
86005450	53799	VAC MOTOR ASM, 36VDC 3 STAGE		
86230800	140550	BRUSH SET, VACUUM MOTOR AMETEK		
86135310	140686	BRUSH SET, VAC 24V/36V WINDSOR		
86001460	140552	BRUSH SET, DRIVE MOTOR		
86001890	14418	BRUSH SET, SCRUB MOTOR		
86009200	81535	KNOB, 3/8-16 4 PRONG ALUM		
86215180	09142	STEERING PIVOT BEARING		
86002850	27343	CHAIN, #40, 1/2"P MASTER LINK		
86007380	730088	SPACER, .5 OD X .26 ID X 1.5L		
86005610	57016	NUT, 7/8 DIA PUSHLOCK		
86007460	730122	SWITCH ASM, FLOAT		
86001920	14607	BREAKER, 25A 50VDC CIRCUIT		
86002010	14942	BOOT, 3/8 CIRCUIT BREAKER		
86008900	80845	BOOT, SEAL-PUSH BUTTON		
86004420	39609	HOSE ASM, 1.5 BLK VAC X 14		
86002030	17298	CAP, .460ID X 1.25L VINYL		
86007250	730000	40 MESH, STRAINER		
86135480	83052	BRAKE PUCK		
86010330	83053	BRAKE ANVIL		
86006340	66347	RECOVERY DRAIN PLUG		

NOTES:

ACCESSORY PUMP-OPTION

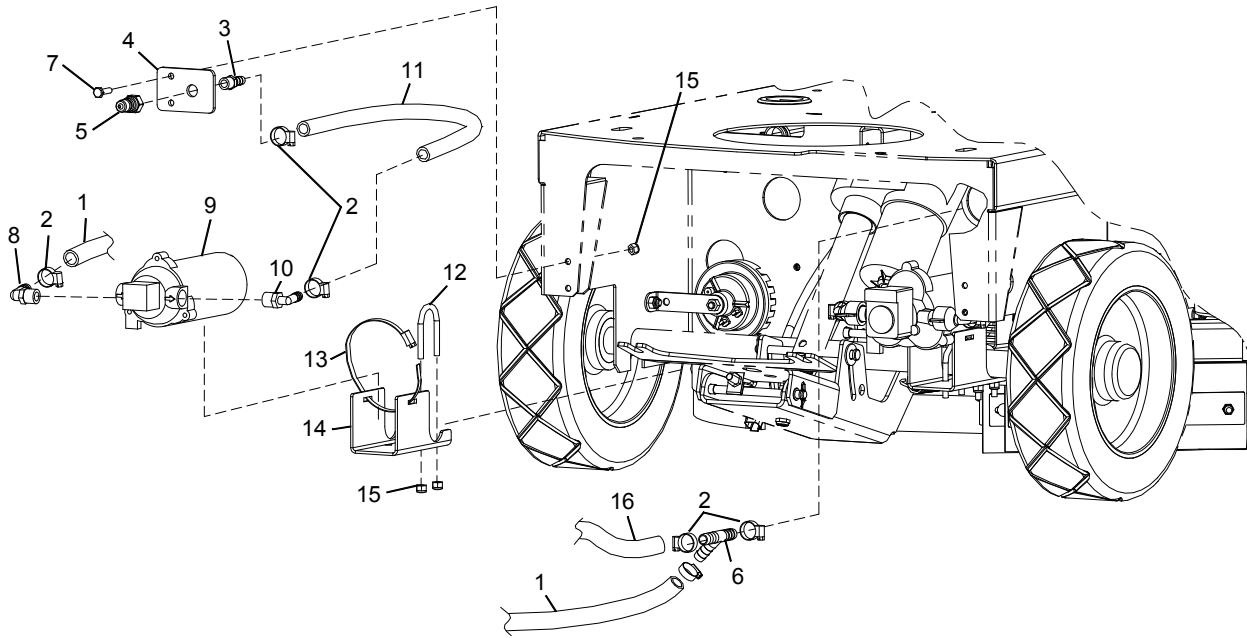

ACCESSORY PUMP-OPTION

REF	PART NO.	PRV NO.	QTY	DESCRIPTION	SERIAL NO. FROM	NOTES:
1	86282170	39611	1	HOSE, 1/2 NYLOBRAID X 26		
2	86233150	20042	6	CLAMP, 3/8 HOSE (D-SLOT)		
3	86197550	40014	1	HOSEBARB, 1/4MPT X 3/8 DL		
4	86081820	62838	1	PLATE, ACCESSORY BULKHEAD		
5	86005580	56012	1	NIPPLE, 1/4 FPT OD		
6	86240410	40078	1	HOSEBARB, 1/2 TEE		
7	86273810	70018	2	SCR, 1/4-20 X 1 HHCS SS		
8	86197940	40027	1	HOSEBARB, 3/8 MPT X 1/2 90 D DL		
9	86006100	65176	1	PUMP ASM, 36V ACCESSORY		
10	86001550	40043	1	HOSEBARB, 3/8 MPT X 3/8 90D		
11	86281520	39413	1	HOSE, 3/8 NYLOBRAID X 17"		
12	86226900	14236	2	U-BOLT, 1/4-20 X 1.5		
13	86233370	80651	1	CLAMP, HOSE WORM DRIVE 2.7-3.7		
14	86069980	140556	1	BRKT, PUMP MOUNT		
15	86005810	57245	6	NUT, 1/4-20 HEX NYLOCK SS		
16	86281000	39241	1	HOSE, 1/2 WIRE BOUND X 10"		

BACK-UP ALARM-OPTION

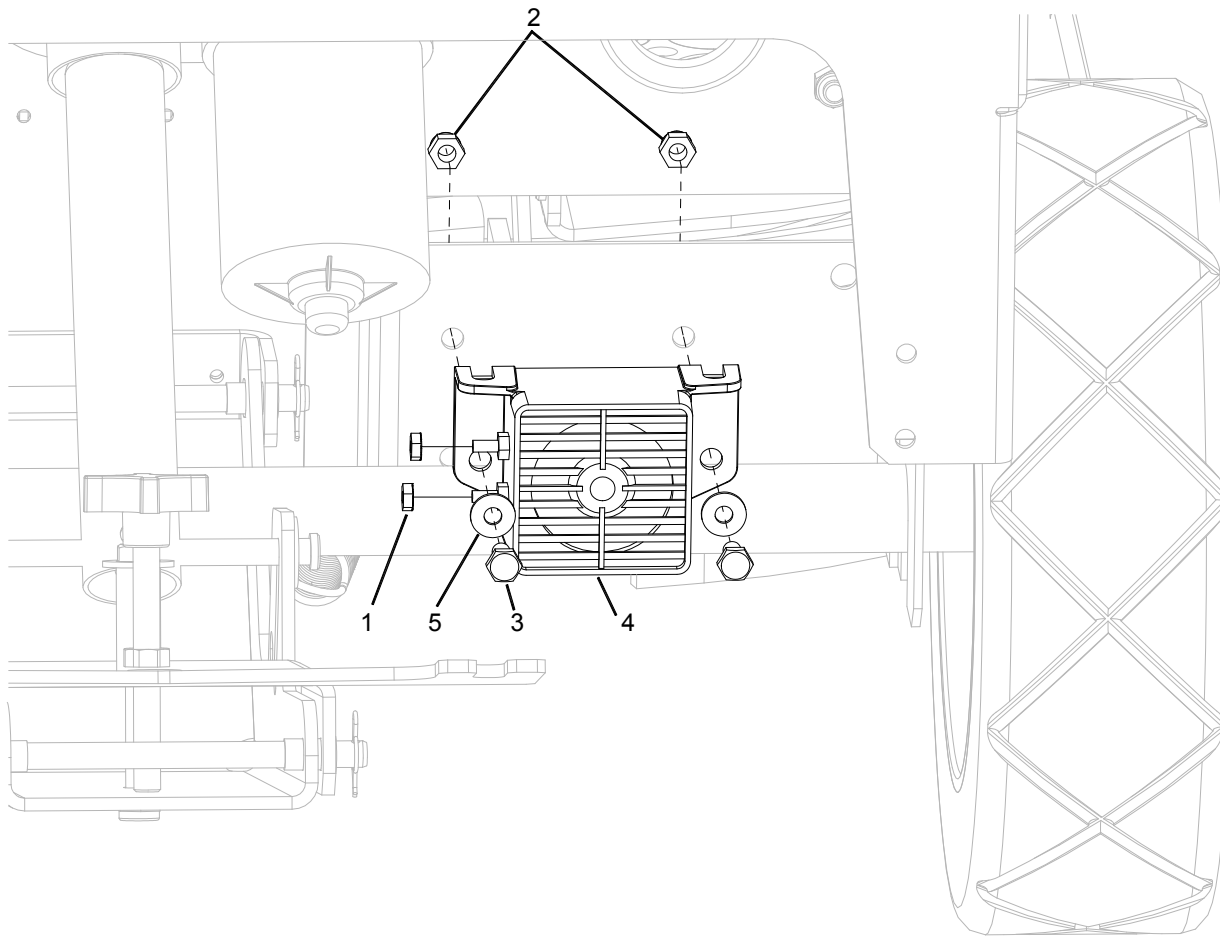

BACK-UP ALARM-OPTION

REF	PART NO.	PRV NO.	QTY	DESCRIPTION	SERIAL NO. FROM	NOTES:
1	86005720	57106	2	NUT, 8-32 W/ STAR WASHER PLTD		
2	86005810	57245	2	NUT, 1/4-20 HEX NYLOCK SS		
3	86273750	70011	2	SCR, 1/4-20 X 5/8 HHCS SS NP		
4	86227260	82332	1	ALARM, BACK UP		
5	86010630	87013	2	WASHER, 1/4 ID X 5/8 OD SS		

DUAL VACUUM MOTOR-OPTION

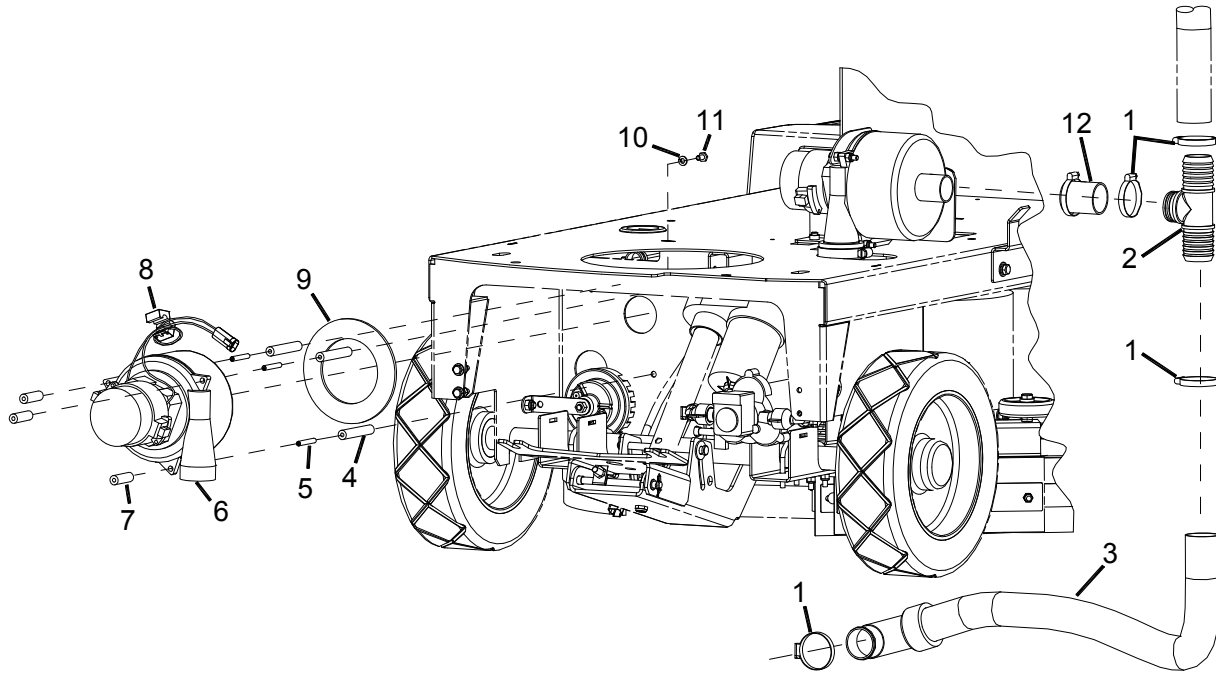

DUAL VACUUM MOTOR-OPTION

REF	PART NO.	PRV NO.	QTY	DESCRIPTION	SERIAL NO. FROM	NOTES:
1	86233140	20041	4	CLAMP, 2.0" WORM GEAR		
2	86076840	40092	1	HOSEBARB, 1.50 TEE MACHINED		
3	86004370	39547	1	HOSE ASM, 1.5 BLK VAC X 21		
4	86007770	73566	3	SPACER, 1/2 OD X 3.0 W/1/4-20 AL		
5	86276370	70638	3	SCR, 1/4-20 X 1.75 SSSCU		
6	86005450	53799	1	VAC MOTOR ASM, 36VDC 3 STAGE		
-	86230800	140550	1	BRUSH SET, VACUUM AMETEK		SERVICE ONLY
-	86135310	140686	1	BRUSH SET, VAC 24V/36V WINDSOR		SERVICE ONLY
7	86005620	57021	3	NUT, 1/4-20 X .962 WELL		
8	86235780	34164	1	FERRITE CLAMP, 1.14 X 1.28 X .583		
9	86003750	35122	1	GASKET, 230V C17EI/C20 VAC MOTOR		
10	86010780	87162	3	WASHER, 1/4 SPLIT LOCK		
11	86273830	70020	3	SCR, 1/4-20 X 1.2 HHCS SS		
12	86076800	39612	1	HOSE, 1.5 ID X 2.0 L		

WARNING LIGHT-OPTION

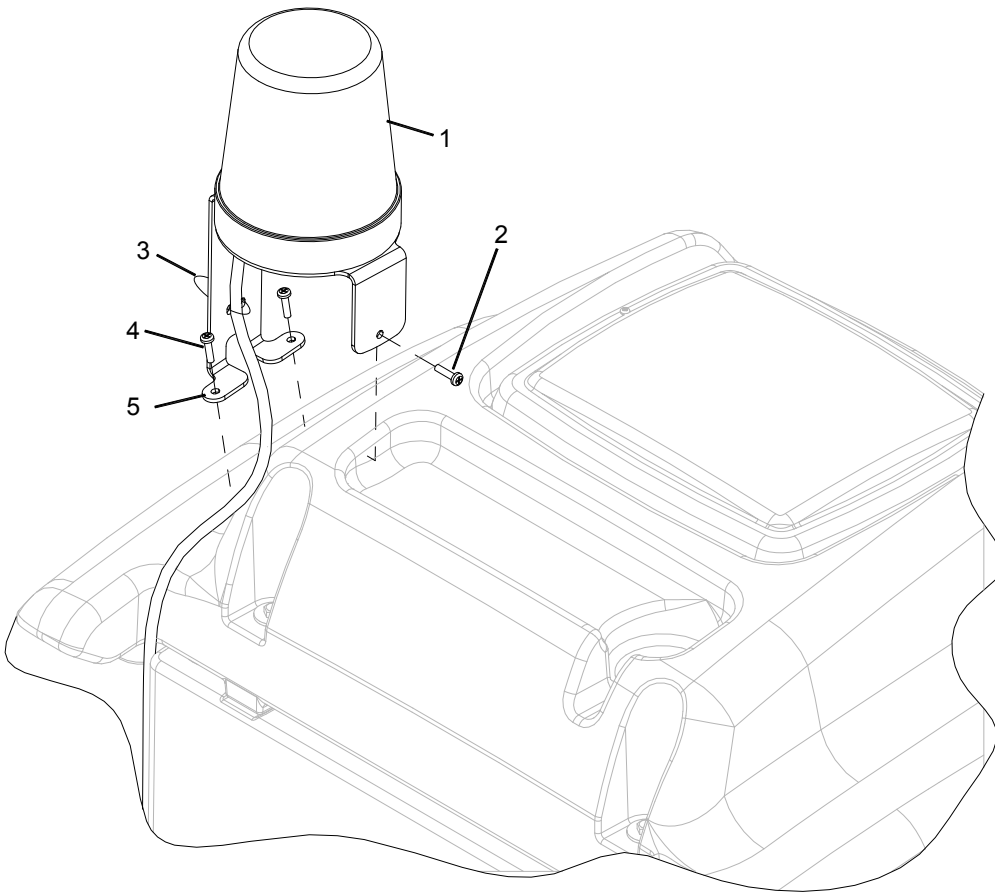

WARNING LIGHT-OPTION

REF	PART NO.	PRV NO.	QTY	DESCRIPTION	SERIAL NO. FROM	NOTES:
1	86025990	51286	1	LIGHT ASM, FLASHING 36V AMBER		
2	86276600	70696	3	SCR, #10 X 3/4 PTHSMS SS		
3	86264950	27746	5	CABLE TIE, .19W X 11.5L BLK		
4	86275730	70534	3	SCR, 1/4-14 X 3/4 TEKS/3 HWHS PLTD		
5	86069970	140555	1	BRKT, LIGHT MOUNT		



Manufacturers of Innovative Building Maintenance Equipment

Windsor Industries, Inc.
1351 West Stanford Avenue
Englewood, CO 80110 USA

Phone: 303.762.1800
FAX: 303.762.0817
<http://www.windsorind.com>

EC Declaration of Conformity

We herewith declare, Windsor Industries, Inc.
1351 W. Stanford Ave.
Englewood, CO 80110-5545 USA

that the following product complies with the appropriate essential health and safety requirements of the relevant EC Directives listed below, based on the relevant sections of the applicable EC standards and other normative documents.

Product:	Saber Glide 28	Saber Glide 32
	Saber Glide 28 Gel	Saber Glide 32 Gel
	Saber Glide 28 Euro	Saber Glide 32 Euro

Product Identification: Rated 36 VDC 80 A

Trademark:



Model/Type Ref.:	SG28	SG32
	SGG28	SGG32
	SGE28	SGE32

Product Description: This product is a battery powered, self-propelled, wet floor scrubber intended for commercial use.

Applicable EC Directives:
EC Machinery Directive
(89/392/EEC & 91/368/EEC & 93/44/EEC & 93/68/EEC)
EC Low Voltage Directive
(73/23/EEC & 93/68/EEC)
EC Directive of Electromagnetic Compatibility
(89/336/EEC & 93/68/EEC)

Applicable Harmonized Standards:
EN 60335-1: 1991
EN 60335-2-67: 1992
EN 60335-2-72: 1995
EN 55022: 1998-09
EN 55011: 1998-05
EN 61000-6-2: 1999
EN 61000-4-2: 1995
EN 61000-4-3: 1997

Authorized Signature

3/20/03
Date

Title of Signature: Vice President, Windsor Industries, Inc.





Manufacturers of Innovative Building Maintenance Equipment

Windsor Industries, Inc.
1351 West Stanford Avenue
Englewood, CO 80110 USA

Phone: 303.762.1800
FAX: 303.762.0817
<http://www.windsorind.com>

EC Declaration of Conformity

We herewith declare, Windsor Industries, Inc.
1351 W. Stanford Ave.
Englewood, CO 80110-5545 USA

that the following product complies with the appropriate essential health and safety requirements of the relevant EC Directives listed below, based on the relevant sections of the applicable EC standards and other normative documents.

Product: Saber Glide 36
Saber Glide 36

Product Identification: Rated 36 VDC 95 A

Trademark:



Model/Type Ref.: SG36
SGE36

Product Description: This product is a battery powered, self-propelled, wet floor scrubber intended for commercial use.

Applicable EC Directives: EC Machinery Directive
(89/392/EEC & 91/368/EEC & 93/44/EEC & 93/68/EEC)
EC Low Voltage Directive
(73/23/EEC & 93/68/EEC)
EC Directive of Electromagnetic Compatibility
(89/336/EEC & 93/68/EEC)

Applicable Harmonized Standards: EN 60335-1: 1991
EN 60335-2-67: 1992
EN 60335-2-72: 1995
EN 55022: 1998-09
EN 55011: 1998-05
EN 61000-6-2: 1999
EN 61000-4-2: 1995
EN 61000-4-3: 1997

Authorized Signature

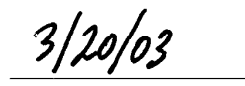
Date

Title of Signature: Vice President, Windsor Industries, Inc.

QUEST for Continuous Improvement.
Windsor's Quality Management System is Certified ISO 9001.



Manufacturers of Innovative Building Maintenance Equipment

Windsor Industries, Inc.
1351 West Stanford Avenue
Englewood, CO 80110 USA

Phone: 303.762.1800
FAX: 303.762.0817
<http://www.windsorind.com>

EC Declaration of Conformity

We herewith declare, Windsor Industries, Inc.
1351 W. Stanford Ave.
Englewood, CO 80110-5545 USA

that the following product complies with the appropriate essential health and safety requirements of the relevant EC Directives listed below, based on the relevant sections of the applicable EC standards and other normative documents.

Product: Saber Glide 28 Saber Glide 28 Gel
Saber Glide 32 Saber Glide 32 Gel

Product Identification: Rated 36 VDC 80 A

Trademark:



Model/Type Ref.: SG28 SGG28
SG32 SGG32

Product Description: This product is a battery powered, self-propelled, wet floor scrubber intended for commercial use.

Applicable EC Directives: EC Machinery Directive
(89/392/EEC & 91/368/EEC & 93/44/EEC & 93/68/EEC)
EC Low Voltage Directive
(73/23/EEC & 93/68/EEC)
EC Directive of Electromagnetic Compatibility
(89/336/EEC & 93/68/EEC)

Applicable Harmonized Standards: EN 60335-1: 1991
EN 60335-2-67: 1992
EN 60335-2-72: 1995
EN 55022: 1998-09
EN 55011: 1998-05
EN 61000-6-2: 1999
EN 61000-4-2: 1995
EN 61000-4-3: 1997

Authorized Signature

8-19-02
Date

Title of Signature: Vice President, Windsor Industries, Inc.

QUEST
For Continuous Improvement.
Windsor's Quality Management System is Certified ISO 9001.

SERIAL NUMBERS

REF. NO.	MODEL: SERIAL #
1	SGE28, SGE32, SGE36, SGEO28, SGEO32: 1000167297
2	SGE28, SGE32, SGE36, SGEO28, SGEO32: 1000160306
3	SGE28, SGE32, SGE36, SGEO28, SGEO32: 1000168775
4	SGE28, SGE32, SGE36, SGEO28, SGEO32: 1000128511
5	SGE28, SGE32, SGE36, SGEO28, SGEO32: 1000167777
6	SGE28, SGE32, SGE36, SGEO28, SGEO32: 1000161812
7	10052480000030, 10052490000225, 10052500000003, 10052520000001
8	10052480000032, 10052490000266, 10052500000003, 10052520000001
9	10052480000032, 10052490000283, 10052500000003, 10052520000001