

# **CUTTER** *SABER™*



## Walk Behind Scrubber

Operating instructions (ENG)

**MODELS:**

**SC326**  
**10052220**

**SCC326**  
**10052260**

**BSCSC326**  
**10052890**

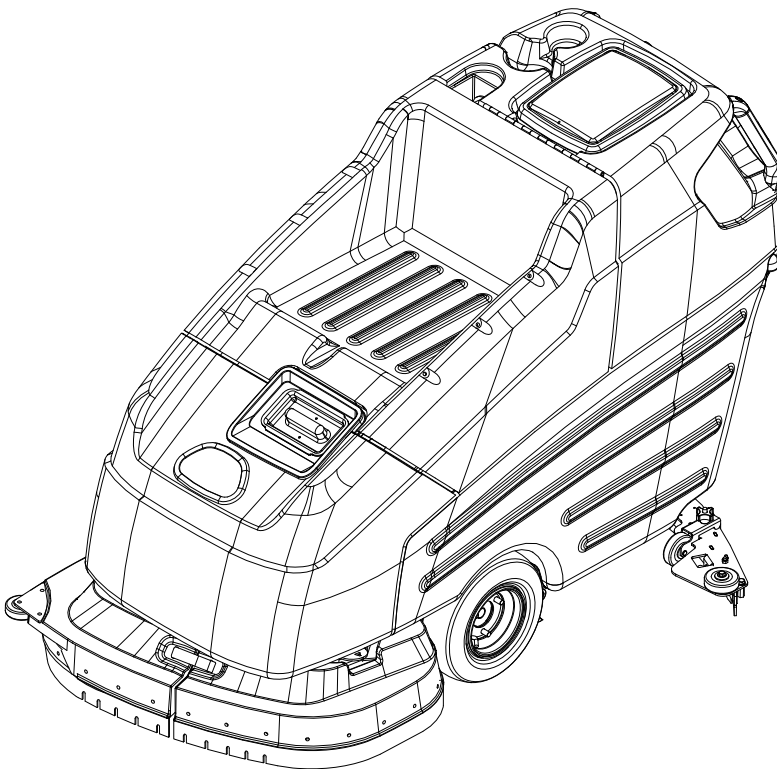

Prior to Serial Number:

10052220000148

10052260000052

10052890000034

Or call Manufacturer.



Read these instructions before using the machine.



Model:	_____
Date of Purchase:	_____
Serial Number:	_____
Dealer:	_____
Address:	_____
Phone Number:	_____
Sales Representative:	_____

### Overview

The Saber Cutter is a battery powered, self-propelled, hard floor scrubber intended for commercial use. The appliance applies a cleaning solution onto a hard floor, scrubs the floor with brushes or pads, and then vacuums the soiled water back into the recovery tank.

## Warranty Registration

Thank you for purchasing a Windsor product. Warranty registration is quick and easy. Your registration will allow us to serve you better over the lifetime of the product.

To register your product go to :  
[www.windsorind.com/WarrantyRegistration.aspx](http://www.windsorind.com/WarrantyRegistration.aspx)

For customer assistance:  
1-800-444-7654



<b>Machine Data Label</b> .....	<b>2</b>	Lift Handle .....	46
Overview .....	2	Lift Handle Linkage .....	48
<b>Table of Contents</b> .....	<b>3</b>	Recovery Tank .....	50
<b>How To Use This Manual</b> .....	<b>4</b>	Scrub Brush/Pad Driver 32 IN. ....	52
 		Scrub Deck Aqua-Mizer .....	54
<i>Safety</i>		Scrub Deck Motors .....	56
Important Safety Instructions .....	5	Scrub Deck Skirt .....	58
Hazard Intensity Level .....	6	Scrub Deck Lift Linkage .....	60
Safety Label Location .....	7	Scrub Deck Lift Linkage .....	62
 		Solution .....	64
<i>Operations</i>		Squeegee .....	68
Technical Specifications .....	8	Squeegee Lift Linkage (Lower) .....	70
How The Machine Works .....	10	Vacuum .....	72
Components .....	11	Wheels & Frame .....	74
Controls .....	12	Wiring-Battery .....	76
<b>Machine Operation</b> .....	<b>16</b>	Wiring Group - Control Panel .....	78
Pre-Run Machine Inspection .....	16	Wiring Group - Main Harness .....	80
Starting Machine .....	16	Wiring Group - Schematic-SC326 .....	82
Emergency Stop Procedures .....	16	Wiring Group - Schematic-SCC326 .....	83
Filling Solution Tank .....	16	 	
Normal Scrubbing .....	17	<i>Options</i>	
Solution Tank .....	18	Brake .....	86
Recovery Tank .....	18	Emergency Stop .....	88
 		Accessory Pump .....	90
<i>Maintenance</i>		Battery Charger-SCC326 .....	92
Service Schedule .....	19	 	
Batteries .....	21	Suggested Spare Parts .....	94
To Charge The Batteries .....	22		
Changing Batteries .....	23		
<b>Squeegee Blades</b> .....	<b>24</b>		
Adjusting Squeegee .....	24		
To Remove Squeegee Assembly .....	24		
To Adjust Squeegee Pitch .....	25		
To Adjust Amount of Rear Squeegee Deflection ..	25		
To Replace Aqua-Mizer Squeegee Blades .....	25		
Scrub Brushes .....	26		
Recovery Tank Float Shut-Off .....	26		
Solution Strainer .....	27		
Changing Brush Motors .....	27		
Traction Motor .....	28		
Circuit Breakers .....	28		
Brush Shroud & Brush Skirts .....	28		
Vacuum Motor .....	29		
Machine Troubleshooting .....	31		
<i>Parts</i>			
Control Handle .....	36		
Cover (Front) & Tank Mount .....	38		
Cover (Top) & Tank Mount .....	40		
Decal .....	42		
Electrical Panel .....	44		

## How To Use This Manual

This manual contains the following sections:

- How to Use This Manual
- Safety
- Operations
- Maintenance
- Parts List

The HOW TO USE THIS MANUAL section will tell you how to find important information for ordering correct repair parts.

Parts may be ordered from authorized dealers. When placing an order for parts, the machine model and machine serial number are important. Refer to the MACHINE DATA box which is filled out during the installation of your machine. The MACHINE DATA box is located on the inside of the front cover of this manual.

Model:	_____
Date of Purchase:	_____
Serial Number:	_____
Dealer:	_____
Address:	_____
Phone Number:	_____
Sales Representative:	_____

The model and serial number of your machine is located on the back of the machine.

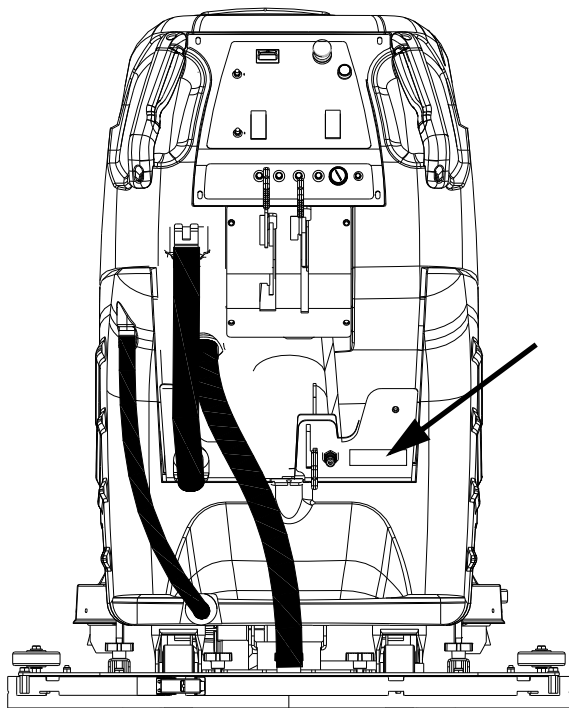

The SAFETY section contains important information regarding hazardous or unsafe practices of the machine. Levels of hazards are identified that could result in product damage, personal injury, or severe injury resulting in death.

The OPERATIONS section is to familiarize the operator with the operation and function of the machine.

The MAINTENANCE section contains preventive maintenance to keep the machine and its components in good working condition. They are listed in this general order:

- Batteries
- Scrub Brushes
- Adjusting Squeegee
- Scrub Deck Skirts
- Squeegee Blade
- Service Schedule

The PARTS LIST section contains assembled parts illustrations and corresponding parts list. The parts lists include a number of columns of information:

- **REF** – column refers to the reference number on the parts illustration.
- **PART NO.** – column lists the part number for the part.
- **QTY** – column lists the quantity of the part used in that area of the machine.
- **DESCRIPTION** – column is a brief description of the part.
- **SERIAL NO. FROM** – If this column has an (\*) and a Reference number, see the SERIAL NUMBERS page in the back of your manual. If column has two asterisk (\*\*), call manufacturer for serial number. The serial number indicates the first machine the part number is applicable to. The main illustration shows the most current design of the machine. When a boxed illustration is shown, it displays the older design.
- **NOTES** – column for information not noted by the other columns.

*NOTE: If a service or option kit is installed on your machine, be sure to keep the KIT INSTRUCTIONS which came with the kit. It contains replacement parts numbers needed for ordering future parts.*

*NOTE: The manual part number is located on the lower left corner of the front cover.*

# Important Safety Instructions

When using this machine, basic precaution  
must always be followed, including the following:

**READ ALL INSTRUCTIONS BEFORE USING THIS MACHINE.**

**⚠ WARNING:** To reduce the risk of fire, electric shock, or injury:

**Use only** indoors. Do not use outdoors or expose to rain.

**Use only** as described in this manual. Use only manufacturer's recommended components and attachments.

If the machine **is not working properly**, has been dropped, damaged, left outdoors, or dropped into water, return it to an authorized service center.

**Do not** operate the machine with any openings blocked. Keep openings free of debris that may reduce airflow.

This machine **is not** suitable for picking up hazardous dust.

**Machine can cause a fire** when operating near flammable vapors or materials. Do not operate this machine near flammable fluids, dust or vapors.

**This machine is suitable for commercial use, for example in hotels, schools, hospitals, factories, shops and offices for more than normal housekeeping purposes.**

Maintenance and repairs **must be done** by qualified personnel.

If foam or liquid comes out of machine, **switch off immediately**.

**Disconnect** battery before cleaning or servicing.

Before the machine is discarded, the batteries **must be removed** and properly disposed of.

Make sure all warning and caution labels **are legible and properly attached** to the machine.

**During operation**, attention shall be paid to other persons, especially children.

**Before use** all covers and doors shall be put in the positions specified in the instructions.

**When leaving unattended**, secure against unintentional movement.

**The machine shall only** be operated by instructed and authorized persons.

**When leaving unattended**, switch off or lock the main power switch to prevent unauthorized use.

**Only chemicals recommended** by the manufacturer shall be used.

**This appliance has been designed** for use with the brushes specified by the manufacturer. The fitting of other brushes may affect its safety.

**Do not** use on surfaces having a gradient exceeding 2% unless the optional parking brake is installed on the machine.

**READ AND SAVE THESE INSTRUCTIONS**

The following symbols are used throughout this guide as indicated in their descriptions:

### Hazard Intensity Level

There are three levels of hazard intensity identified by signal words -**WARNING** and **CAUTION** and **FOR SAFETY**. The level of hazard intensity is determined by the following definitions:

#### **⚠ WARNING:**

**WARNING** - Hazards or unsafe practices which COULD result in severe personal injury or death.

#### **⚠ CAUTION:**

**CAUTION** - Hazards or unsafe practices which could result in minor personal injury or product or property damage.

***FOR SAFETY: To Identify actions which must be followed for safe operation of equipment.***

Report machine damage or faulty operation immediately. Do not use the machine if it is not in proper operating condition. Following is information that signals some potentially dangerous conditions to the operator or the equipment. Read this information carefully. Know when these conditions can exist. Locate all safety devices on the machine. Please take the necessary steps to train the machine operating personnel.

***FOR SAFETY:***

**DO NOT OPERATE MACHINE:**

Unless Trained and Authorized.

Unless Operation Guide is Read and understood.

In Flammable or Explosive areas.

In areas with possible falling objects.

***WHEN SERVICING MACHINE:***

**Avoid moving parts. Do not wear loose clothing; jackets, shirts, or sleeves when working on the machine. Use Windsor approved replacement parts.**

#### **⚠ WARNING:**

**Batteries emit hydrogen gas. Explosion or fire can result. Keep sparks and open flame away. Keep top cover in raised position when charging. Keep sparks and flames away from the batteries. Do not smoke around batteries.**

#### **⚠ WARNING:**

**Disconnect batteries before working on machine. Only qualified personnel should work inside machine. Always wear eye protection and protective clothing when working on or near batteries. Avoid skin contact with the acid contained in the batteries.**

#### **⚠ WARNING:**

**Never allow metal to lie across battery tops.**

### Safety Label Location

NOTE: These drawings indicate the location of safety labels on the machine. If at any time the labels become illegible, promptly replace them.

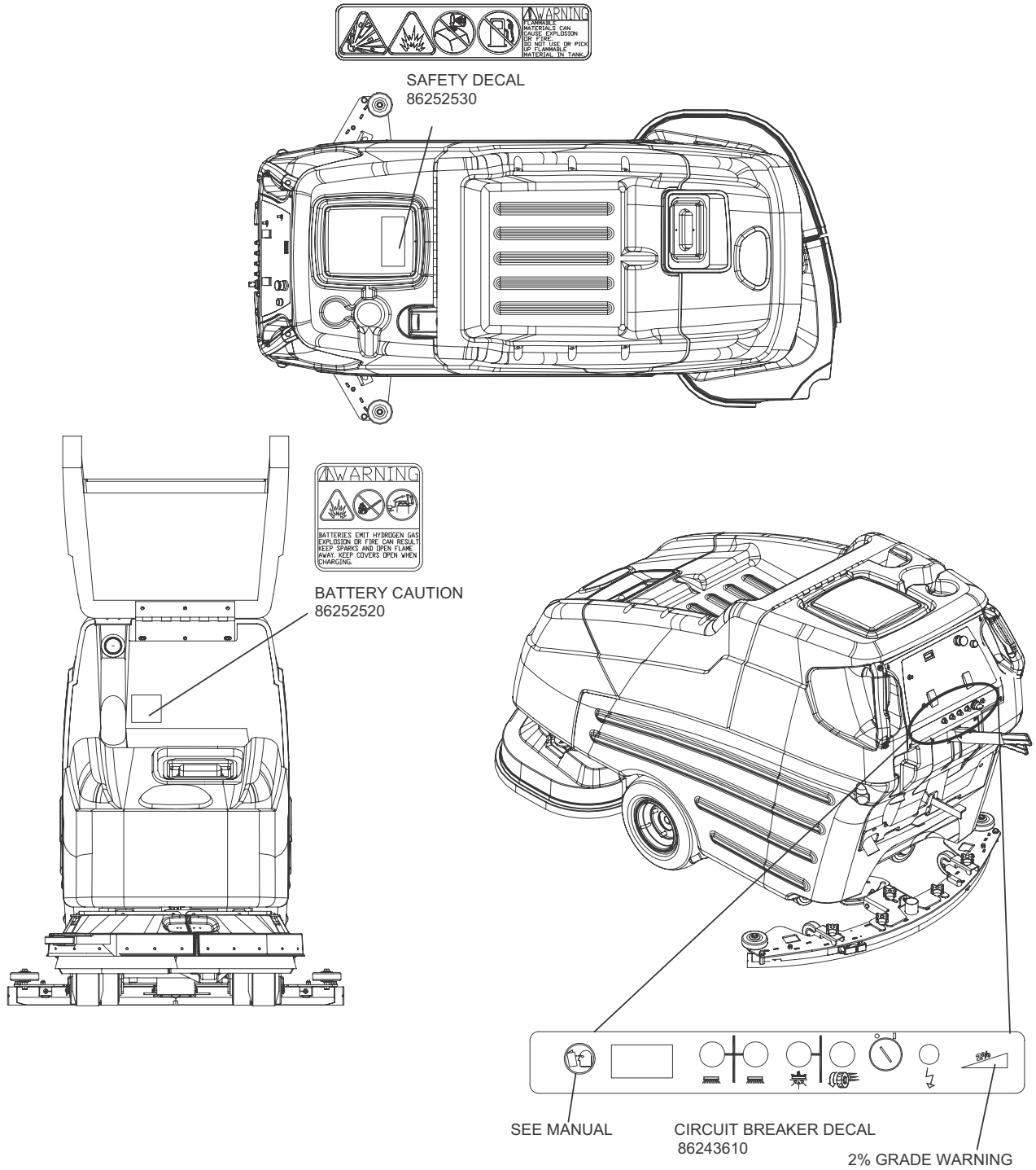

**Technical Specifications**

ITEM	DIMENSION/CAPACITY
Nominal power	2160 W
Rated Voltage	36 Volt DC
Rated Amperage	60 amps
Batteries	6 x 6 volt 250-305-335 AH @ 20 Hr rate
Scrub Brush Motors	2 x .75 hp (.56 kW )
Vacuum Motor	3 Stage .75 hp (.56 kW )
Propelling Motor	.75 hp (.56 kW )
Mass (GVW)	1265 lb (574 kg) w/335 AH batteries
Weight empty without batteries	433 lb (196 kg)
Solution Control	Gravity feed, fully variable with automatic shut-off in neutral
Solution tank capacity	32 gal (118 L)
Recovery tank capacity	35 gal (123 L)
Scrub brush diameter 32 in. (81 cm) scrub head	16 in (41 cm)
Scrub brush pressure	Mechanical, 80 lbs floating
130 lbs restricted (356n-578n)	
Scrub brush speed	200 rpm
Tires	2 x 12 in (30.5 cm) Non-Mark Foam Fill
Casters	2 x 4 in (10.2 cm) polyurethane, Non-Mark
Foundation Pressure	64 lbs/in <sup>2</sup> (441 kPa)
Maximum Speed	3.2 miles/hour (5.2 kW/hour)
Frame Construction	Powder coated steel
Brakes (optional)	Tire lock parking
Minimum aisle u-turn width with 32 in. (81 cm) scrub head	69 inches (175 cm)
Maximum rated climb and descent angle with empty tanks and without optional parking brake	2%
Maximum rated climb and descent angle with full tanks and without optional parking brake	2%



### Technical Specifications

ITEM	MEASURE
Height	46 in (117 cm)
Length with 32 in. (81 cm) scrub head	71 in (180)
Width without squeegee and scrub head	28 in (71 cm)
Width of squeegee for 32 in. (81 cm) scrub head	39 in (99 cm)
Width of scrub path for 32 in. (81 cm) scrub head	32 in (81 cm)

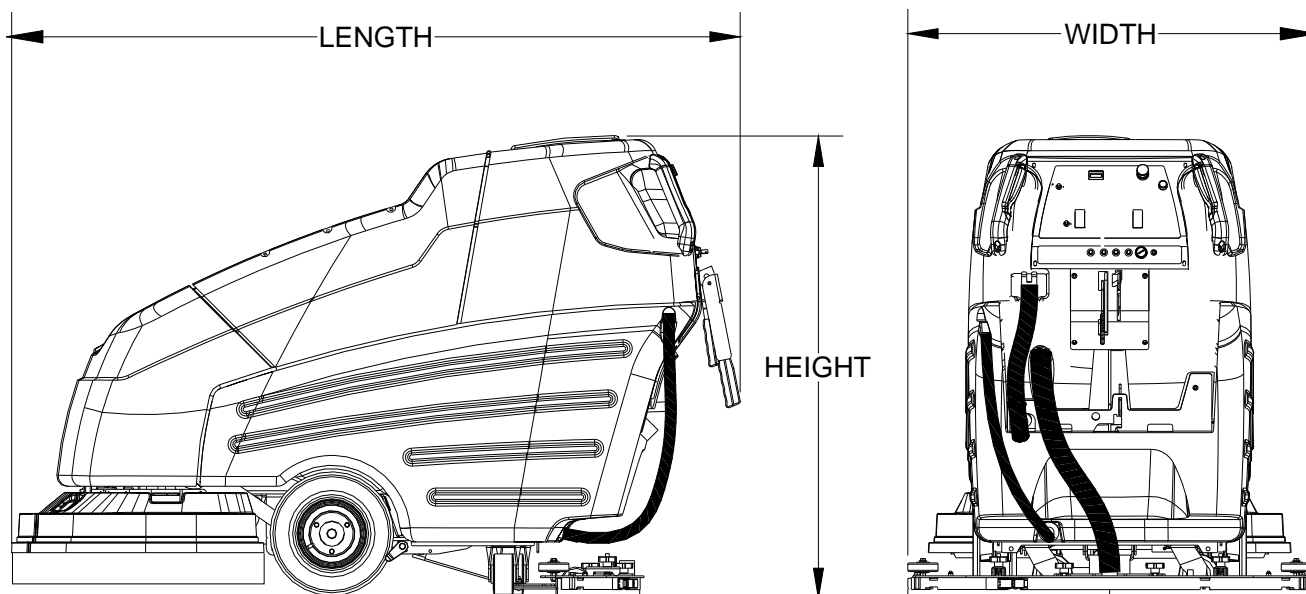

#### SPECIAL NOTES:

The sound pressure level at the operator's ear was measured to be 75 dBA. This was a nearfield, broad-band measurement taken in a typical industrial environment on a tile floor. This appliance contains no possible source of impact noise. The instantaneous sound pressure level is below 63 Pa.

The weighted root mean square acceleration at the operator's arms was measured to be below 2.5m/s<sup>2</sup>. This was a tri-axial, third-octave-band measurement made during normal operation on a composite tile floor. The measurement and related calculations were made in accordance with ANSI S3.34-1986.

### How The Machine Works

The Saber Cutter is a battery powered, self-propelled, hard floor scrubber intended for commercial use. The appliance applies a cleaning solution onto a hard floor, scrubs the floor with brushes, and then vacuums the soiled water back into the recovery tank.

The machine's primary systems are the solution system, scrub system, recovery system, and directional control system.

The function of the solution system is to store cleaning solution and deliver it to the scrub system. The solution system consists of the solution tank, strainer, valve and controls. The solution tank stores cleaning solution (water and detergent) until it is delivered to the scrub system. The strainer protects the valve from debris. The valve is a solenoid type valve, which controls the delivery of cleaning solution to the scrub system. The valve automatically prevents solution flow unless the scrub brushes are turned on and the machine is being propelled. The solution control knob controls the amount of cleaning solution delivered to the scrub system by controlling the amount of time the valve is open.

The function of the scrub system is to scrub the floor. The scrub system consists of two rotary type disk scrub brushes, motors, scrub deck skirt, lift mechanism and controls. The brushes scrub the floor and the motors drive the brushes. The brush drive hubs allow the scrub brushes to follow irregularities and changes in the floor without losing contact with floor. The scrub deck skirt controls the cleaning solution on the floor so that the squeegee can pick it up. The brush lever is used to raise and lower the deck.

The function of the recovery system is to vacuum the soiled water back into the recovery tank. The recovery system consists of the squeegee, vacuum motor, float ball filter, recovery tank and controls. The squeegee wipes the dirty solution off the floor as the machine moves forward. The vacuum motor provides suction to draw the dirty solution off the floor and into the recovery tank. The recovery tank stores the dirty solution. The float ball filter protects the vacuum fan from debris and shuts off air going to the recovery tank when tank is full. When flow of air is shut off the vacuum motor will continue to run. At this time the recovery tank must be drained.

The function of the directional control system is to control the direction and speed of the machine. The directional control system consists of the propel control buttons, reverse button, speed control knob/potentiometer, controller and transaxle. The propel controls actuate switches which cause the machine to move forward. For reverse motion depress the reverse button while depressing one of the propel controls. The speed control knob actuates a potentiometer, which signals speed. The controller interprets the forward/reverse signals from the switches and the speed signal from the potentiometer to command the transaxle to propel the machine in the direction, and at the speed, desired.

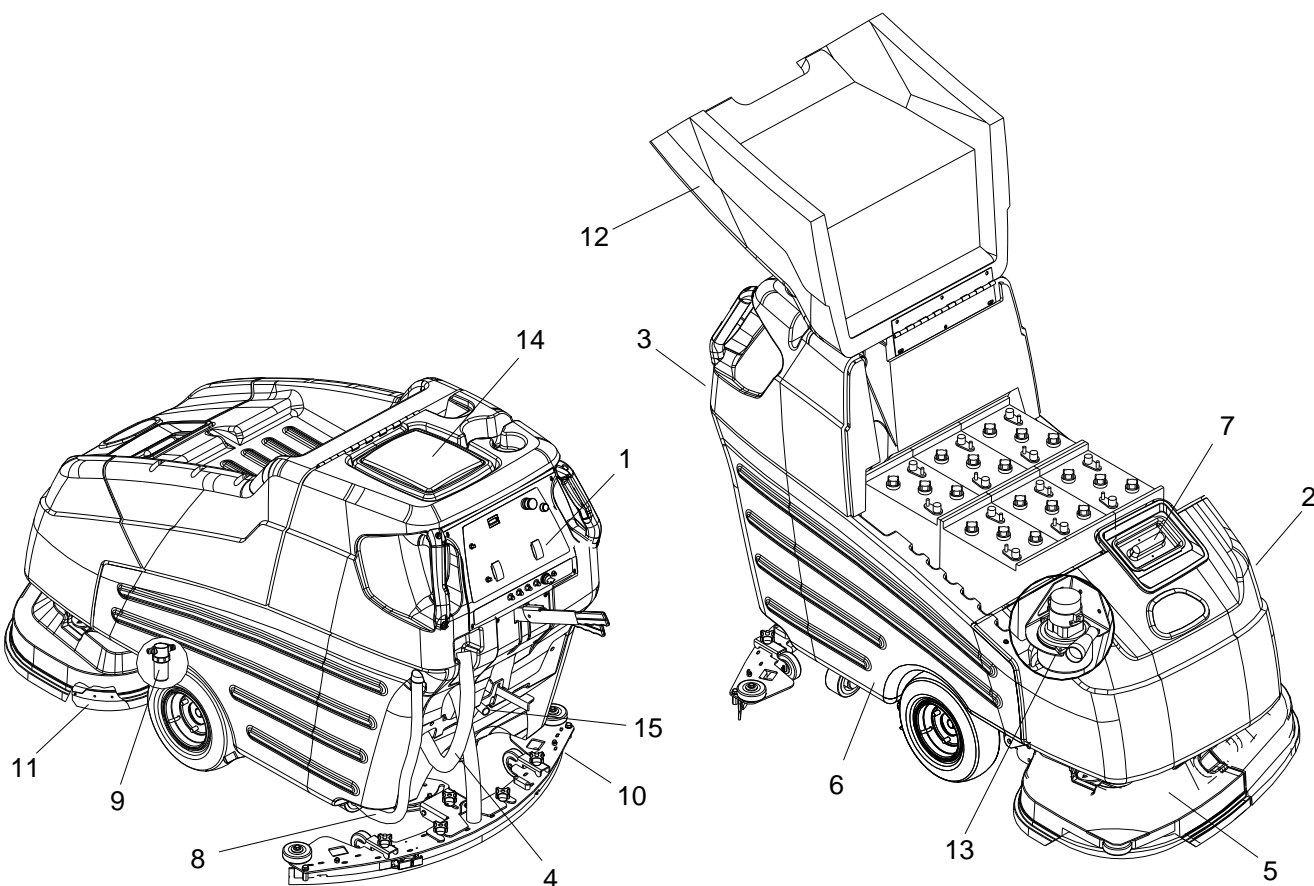
**Components**

1. Control Panel
2. Front Cover
3. Recovery Tank
4. Recovery Tank Drain Hose
5. Scrub Head Shrouds
6. Solution Tank
7. Solution Tank Cover
8. Solution Tank Drain Hose
9. Solution Strainer
10. Squeegee
11. Aqua-Mizer
12. Top Cover
13. Vacuum Motor
14. Recovery Tank Dome
15. Accessory Pump Port (Optional)

Controls

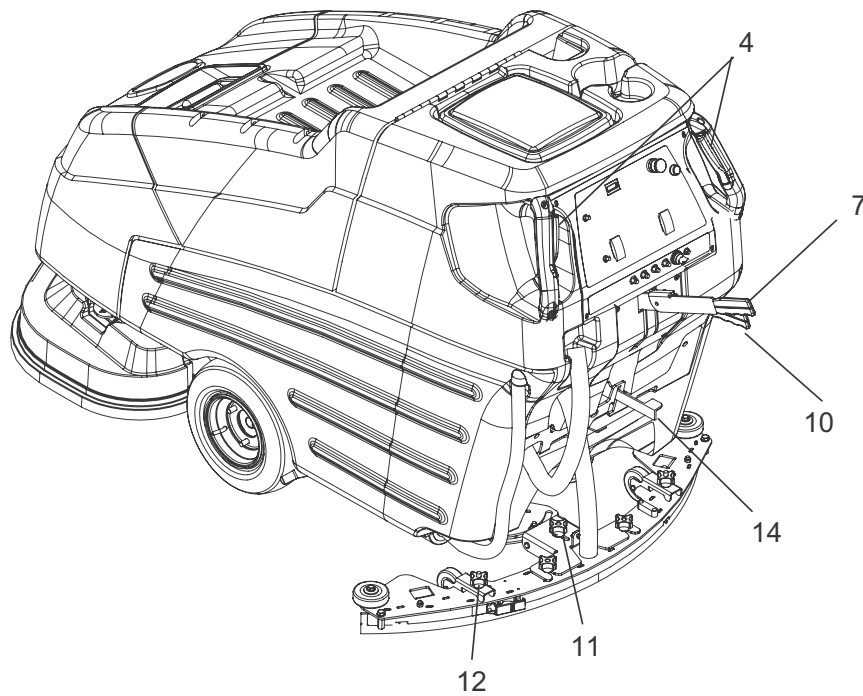
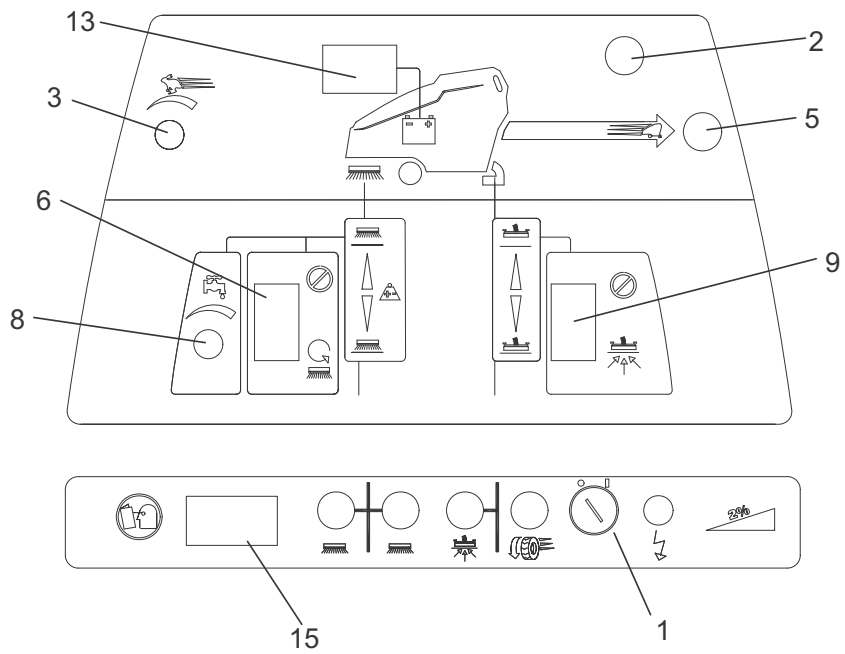

1. Key Switch
2. Emergency Shut-Off Switch
3. Speed Control Knob
4. Propel Control Lever
5. Reverse Button
6. Brush Switch
7. Brush Lift Lever
8. Solution Control Knobs
9. Vacuum Switch
10. Squeegee Lift Lever
11. Squeegee Pitch Adjustment Knob
12. Squeegee Deflection Adjustment Knobs
13. Battery Charge Level Indicator
14. Parking Brake (Optional)
15. Hour Meter (Optional)

#### 4. PROPEL CONTROL LEVERS

Controls the machine direction, and scrub brushes and solution flow.

To propel machine forward, squeeze either propel lever.

The scrub brushes will not rotate and the solution will not flow to scrub deck with the propel levers in neutral.

#### 5. REVERSE BUTTON

Controls the reverse function.

To propel machine backward, push the reverse button while squeezing either propel lever.

#### 6. BRUSH SWITCH

Controls the scrub brush motors.

To turn scrub brushes on, press the bottom of the switch. The brushes will not rotate with the propel control levers in neutral.

To turn scrub brushes off, press the top of the switch.

#### 1. KEY SWITCH

Controls the power for machine functions.

To turn machine on, rotate key clockwise.

To turn machine off, rotate key counterclockwise.

***FOR SAFETY: Always remove the key when machine is unattended or during service to prevent unauthorized movement.***

#### 2. EMERGENCY SHUT-OFF SWITCH (OPTIONAL)

Shuts off machine.

To shut off machine, push the switch.

To restart machine, rotate the switch clockwise.

#### 3. SPEED CONTROL KNOB

Controls the speed of the machine.

To increase speed, rotate knob clockwise.

To decrease speed, rotate knob counterclockwise.

### **7. BRUSH PRESSURE LEVER**

Adjusts the amount of brush pressure to the floor by raising or lowering the scrub deck.

To apply brush pressure, lower brush pressure lever to floating position.

To apply additional pressure, place lever in restricted position. Lock the lever into the lower notch. Push the lever forward to move in a downward motion. Pull back on lever and release for floating position.

To decrease brush pressure, raise lever to up position.

### **8. SOLUTION CONTROL KNOB**

Controls solution flow to scrub deck.

To increase flow, rotate knob clockwise.

To decrease flow, rotate knob counterclockwise.

If the brush motors are turned off or the propel control levers are in neutral, the flow is automatically interrupted until the motors are turned on again. This feature prevents unintentional draining of the solution tank and allows the operator to adjust the solution flow to the scrub deck without resetting each time the scrubbing operation is interrupted.

### **9. VACUUM SWITCH**

Controls the vacuum motor.

To start vacuum motor, press the bottom of the switch.

To stop vacuum motor, press the top of the switch.

### **10. SQUEEGEE LIFT LEVER**

Raises and lowers the squeegee.

To lower the squeegee, lift the lever from its raised position.

To raise the squeegee, lift the lever from its lowered position.

### **11. SQUEEGEE PITCH ADJUSTMENT KNOB**

Adjusts the deflection at the ends of the squeegee.

To increase squeegee blade deflection at the ends, turn knob counterclockwise.

To decrease squeegee blade deflection at the ends, turn knob clockwise.

### **12. SQUEEGEE DEFLECTION ADJUSTMENT KNOBS**

Adjusts the deflection along the entire length of the squeegee.

To increase squeegee blade deflection along the entire length, turn the two knobs at the squeegee ends counter-clockwise.

To decrease squeegee blade deflection along the entire length, turn the two knobs at the squeegee ends clockwise.

### **13. BATTERY CHARGE LEVEL INDICATOR**

Indicates the charge level of the batteries.

The meter display is divided into 10 vertical bars. Bar illuminated on the far right indicate full charge. Bars flashing near the left side indicate the batteries should be recharged. Further operation of the machine could damage the machine or the batteries.

When the machine is left overnight with less than a full charge, the display may initially indicate a full charge. It will also indicate a full charge if the batteries are disconnected, then reconnected. After a few minutes of operation the meter will give the correct charge level.

### **14. PARKING BRAKE (OPTIONAL)**

Locks front wheels to prevent unintentional movement.

To set parking brake, push down to lock notch.

To release parking brake, push down and over out of the lock down notch.

### **15. HOUR METER (OPTIONAL)**

Records the number of hours the machine has been in operation. This information is useful in determining when to service the machine.

### Machine Operation

#### Pre-Run Machine Inspection

Do a pre-run inspection to find possible problems that could cause poor performance or lost time from breakdown. Follow the same procedure each time to avoid missing steps.

*NOTE: See maintenance section for pre-run machine inspection checklist items.*

#### Starting Machine

*NOTE: Perform pre-run machine check before operating machine.*

**FOR SAFETY: Before starting machine, make sure that all safety devices are in place and operating properly.**

1. Turn the machine power on.
2. Release the parking brake, if your machine is equipped with this option.
3. Engage the direction propel levers for the desired direction.

#### Emergency Stop Procedures

1. Release the propel levers.
2. Turn machine power off with key switch.
3. If an electrical problem is suspected push in emergency stop button, if machine is equipped with this option.
4. Apply brakes, if your machine is equipped with this option.

#### Filling Solution Tank

**FOR SAFETY: Before leaving or servicing machine; stop on level surface, turn off machine and remove key.**

1. Turn the machine power off.
2. Set the parking brake if your machine is equipped with this option.
3. Remove solution tank cover.
4. Fill the solution tank with clean water, leaving enough room for the required amount of cleaning solution. The solution tank capacity filled to 2" (5 cm) from bottom of fill inlet is 23 gallons (87 liters). The water must not be hotter than 140 F (60 C) to prevent damage to the tank.
5. Measure the chemical into the solution tank. Liquid chemicals should be added to the solution tank after filling with water. Dry chemicals should be thoroughly mixed before being added into solution tank. Commercially available, high alkaline floor cleaners, are suitable for use in the solution system.

*NOTE: Read the chemical manufacturers recommended proportion instructions.*

6. Replace solution tank cover.

#### **⚠ WARNING:**

**Flammable materials can cause an explosion or fire. Do not use flammable materials in the tanks.**





## Double Scrub

For floors which are heavily soiled or have thick accumulations of floor finish may not clean sufficiently with one pass. In these cases it will be necessary to double scrub.

1. To double scrub, make the first pass over the surface being cleaned with the squeegee up, vacuum off, the solution on, Aqua-Mizer removed and brushes down. This allows the solution to stay in contact with the soil while loosening the surface accumulation with the brushes. Allow time for the first application to stay in contact with the floor. Length of time between the first and second pass depends on amount of accumulation and the type of chemical being used. A second scrubbing with the squeegee down and again the solution and brushes on will further loosen soil. The additional application of solution will further assist the difficult cleaning job.

**FOR SAFETY:** When using machine, go slow on inclines and slippery services.

## Emptying And Cleaning Tanks

2. Park the machine next to a floor drain. Drain hose is on left rear corner of the machine.
3. Turn the machine power off and set parking brake, if your machine is equipped with this option.

## Solution Tank

1. Loosen small drain hose from the retainer, then lower hose in direction of the drain.
2. Remove the solution tank cover.
3. Flush the solution tank out with clean water and run several gallons of clean water through systems. Do not use water hotter than 140°F (60°C) to clean tank. Damage may occur.

*NOTE: Never allow solution to remain in tank. Damage to tank, seals and valves could occur.*

4. Secure drain hose into the retainer.

## Recovery Tank

1. Unhook the large drain hose from the retainer. Unscrew the T-handle on plug enough to loosen plug, then lower hose in direction of the drain. Do not stand in front of end of hose. Recovered solution will come out with force. Slowly remove plug from drain hose.
2. Remove the recovery tank dome. Flush the recovery tank out with clean water. Do not use water hotter than 140°F (60°C) to clean tank. Damage may occur.
3. Clean off the float shut-off system and inspect for free movement of float. The float shut-off system is located in the rear of the recovery tank.
4. Replace the drain plug and secure drain hose in bracket.
5. If machine is to be stored, leave the recovery tank dome off.

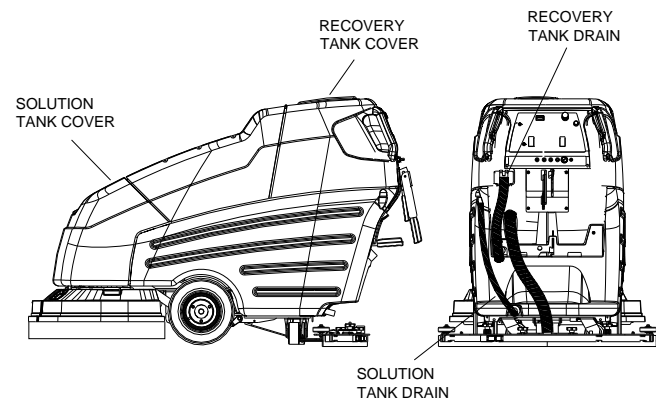

## Service Schedule

MAINTENANCE	DAILY	WEEKLY	MONTHLY	50 HRS	100 HRS	200 HRS
Check batteries after charging; add water if necessary	*					
Check pad wear to prevent buildup of chemicals	*					
Check linkages and connectors for wear and damage	*					
Check hoses for wear, blockages, or damage	*					
Clean squeegee; check for adjustment; inspect for wear	*					
Check handles, switches, knobs, domes, and gaskets for damage	*					
Clean out recovery tank	*					
Clean out solution tank; remove and clean screen	*					
Clean outside of all tanks; check for damage	*					
Run vac motor for at least one minute to allow motor to dry	*					
Store with dome off tank to allow the tank to dry	*					
Check scrub deck splash skirt		*				
Check batteries for corrosion, cracks and evidence of overheating			*			
Check all bearings for noise			*			
Check all gaskets for wear and leakage			*			
Check vac motor carbon brushes			*			
Check brushes for wear; ensure bristles are not damaged			*			
Check linkages for wear and damage			*			
Grease wheels and casters			*			
Grease axle			*			
Check squeegee blades for wear and frame for damage			*			
Check overall performance of machine			*			
Lubricate squeegee caster				*		
Clean batteries and terminals					*	
Thoroughly clean the machine					*	
Check carbon brushes in all vacuum, brush drive, and propel motors						*
Blow out dust in motors						*
Inspect motor commutators						*
Clean chains, cables and pulleys						*
Clean pivot points on squeegee and scrub deck linkages						*

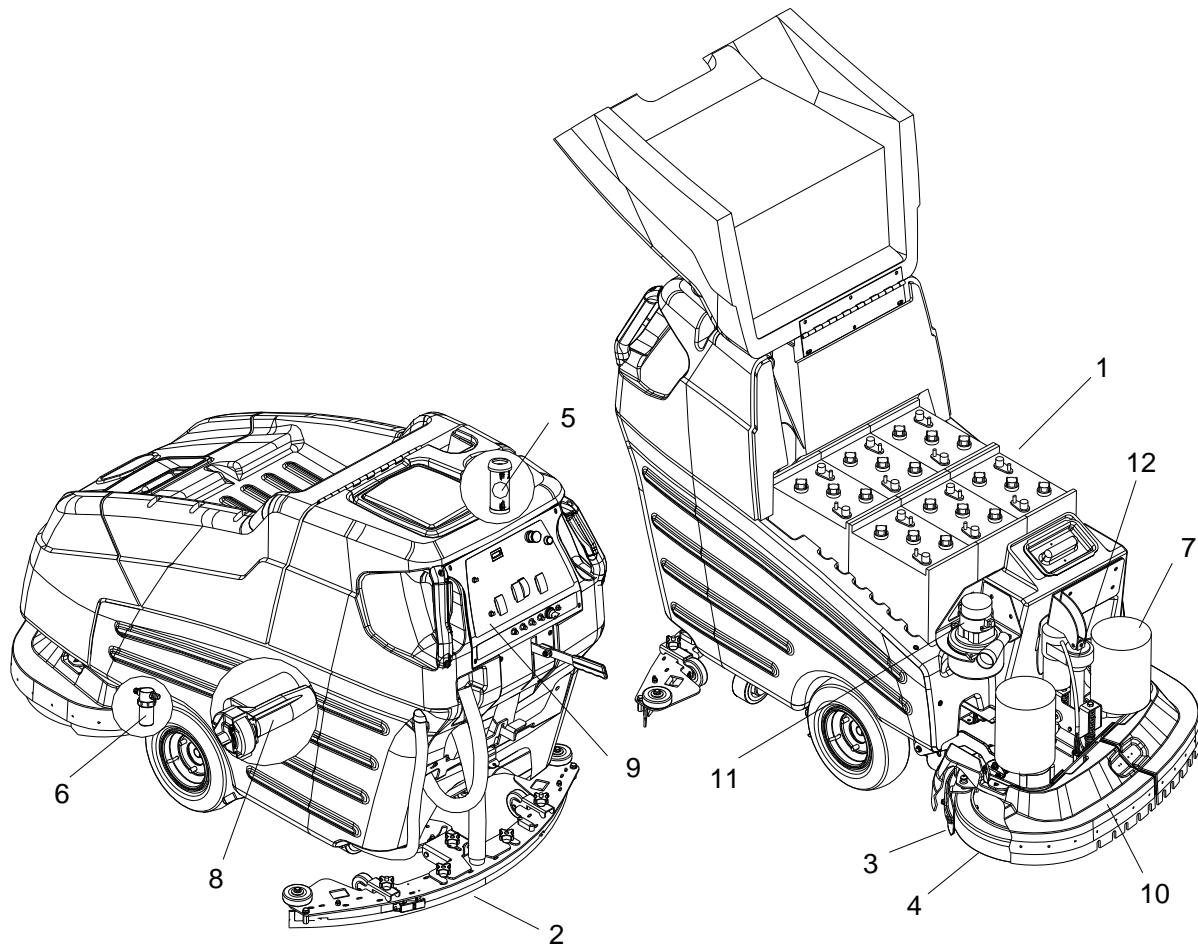

1. Batteries
2. Squeegee
3. Aqua Mizer
4. Scrub Brushes
5. Recovery Tank Float Shut-Off
6. Solution Strainer
7. Brush Motor
8. Traction Motor
9. Circuit Breakers
10. Brush Shroud & Brush Skirts
11. Vacuum Motor
12. Actuator Scrub Deck

## Batteries

The batteries provide the power to operate the machine. The batteries require regular maintenance to keep them operating at peak efficiency.

The machine batteries will hold their charge for long periods of time, but they can only be charged a certain number of times. To get the greatest life from the batteries, charge them when their charge level reaches 25% of a full charge. Use a hydrometer to check the charge level.

Do not allow the batteries to remain in a discharged condition for any length of time. Never expose a discharged battery to temperatures below freezing. Discharged batteries will freeze causing cracked cases. Do not operate the machine if the batteries are in poor condition or if they have a charge level below 25% (specific gravity below 1.155).

Keep all metallic objects off the top of the batteries, as they may cause a short circuit. Replace worn or damaged cables and terminals.

Check the electrolyte level in each battery cell before and after charging the batteries. Never add acid to the batteries, use distilled water. Do not allow water level to fall below the battery plates. Portions of plates exposed to air will be destroyed. Do not overfill. Keep plugs firmly in place at all times.

### **⚠ CAUTION:**

**When servicing machine, avoid contact with battery acid.**

### **⚠ WARNING:**

**Batteries emit hydrogen gas. Explosion or fire can result. Keep sparks and open flame away. Keep covers open when charging.**

### **⚠ WARNING:**

**Wear eye protection and protective clothing when working with batteries.**

### **⚠ WARNING:**

**Charge batteries in a well ventilated area.**

## BATTERY MAINTENANCE

1. When cleaning the batteries, use a solution of baking soda and water. Do not allow the cleaning fluid to enter the battery cells, electrolyte will be neutralized.
2. Maintain the proper electrolyte level in each battery cell. If a cell should accidentally overflow, clean immediately.
3. Wipe off the top of the batteries at least once a week.
4. Test battery condition with a hydrometer at least once a week.
5. Ensure that all connections are tight and all corrosion removed.
6. Every 4 to 6 months, remove that batteries from the machine and clean the battery cases and battery compartment.

### Checking Battery Specific Gravity

Use a hydrometer to check the battery specific gravity.

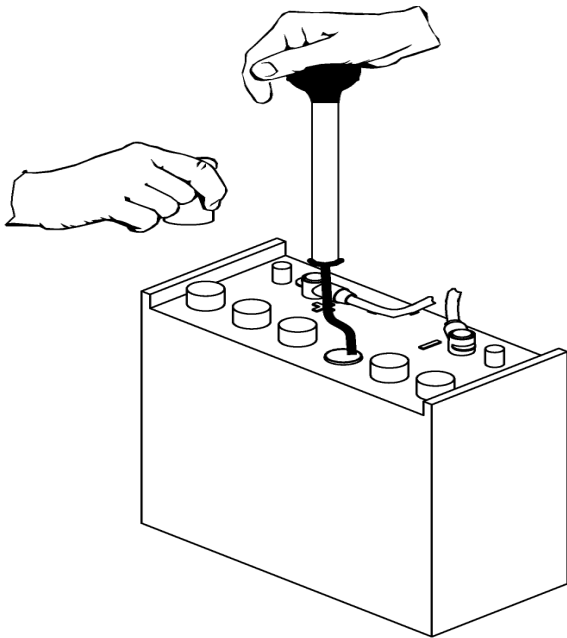

### CHECKING GRAVITY

- a. Hydrometer
- b. Battery

*NOTE: Do not take readings immediately after adding distilled water, if the water and acid are not thoroughly mixed, the reading may not be accurate.*

Check the hydrometer readings against this chart.

SPECIFIC GRAVITY @ 80°F (27°C)	BATTERY CONDITION
1.265	100% CHARGED
1.225	75% CHARGED
1.190	50% CHARGED
1.155	25% CHARGED
1.120	DISCHARGED

*NOTE: If the readings are taken when the battery electrolyte is any temperature other than 80°F (27°C), the reading must be temperature corrected.*

To find the corrected specific gravity reading when the temperature of the battery electrolyte is other than 80°F (27°): Add (+) to the specific gravity reading 0.004 (4 points), for each 10°F (6°C) above 80° (27°C).

Subtract (-) from the specific reading 0.004 (4 points), for each 10°F (6°C) below 80°F (27°C).

### To Charge The Batteries

#### **⚠ WARNING:**

When servicing machine, avoid contact with battery acid.

#### **⚠ CAUTION:**

Batteries emit hydrogen gas. Explosion or fire can result. Keep sparks and open flame away. Keep covers open when charging.

#### **⚠ WARNING:**

Wear eye protection and protective clothing when working with batteries.

#### **⚠ WARNING:**

Charge batteries in a well ventilated area. Leave the battery cover open.

Use a 36 volt, 18 amp maximum output or 25 amp (depending on the size of the batteries), DC charger which will automatically shut off when the batteries are fully charged.

1. Stop the machine in a clean, well ventilated area next to the charger.
2. Turn "OFF" machine.

**FOR SAFETY: Before leaving or servicing machine; stop on level surface, turn off machine and remove key.**

3. Raise the battery cover

#### **⚠ WARNING:**

Batteries emit hydrogen gas. Explosion or fire can result. Keep sparks and open flame away. Keep covers open when charging.

4. Check the electrolyte level in each battery cell. Before charging, add just enough distilled water to cover the plates. After charging is complete, add just enough distilled water to bring up the level to the indicator ring. If the water level is too high before charging, normal expansion rate of the electrolyte may cause an overflow. Resulting in a loss of battery acid balance and damage the machine.

5. Replace the battery caps, and leave them in place while charging.
6. Unplug the battery connector from the machine.

**FOR SAFETY: When charging, connect the charger to the batteries before connecting the charger to the AC wall outlet. Never connect the charger to the AC wall outlet first. Hazardous sparks may result.**

7. Plug the charger connector into the battery connector. Connect the charger AC plug to a wall outlet. The charger gauge should indicate that the batteries are charging.
8. When the batteries are fully charged, disconnect the charger from the AC wall outlet, then disconnect the charger from the batteries.
9. Connect the batteries to the machine connector.
10. Check the electrolyte level. It should be up to the indicator ring. If necessary, add distilled water.
11. Lower the battery cover.

## Changing Batteries

Stop the machine in a clean area next to the charger. Turn off machine.

**FOR SAFETY: Before leaving or servicing the machine; stop on level surface, turn off machine and remove key.**

1. Raise the battery cover.
2. Disconnect battery pack from machine.
3. Use the proper size open end wrench to disconnect main ground wire first and secure cable terminal away from batteries.
4. Disconnect main positive lead and secure cable terminals away from batteries.
5. Loosen both terminals on each jumper cable and remove one at a time.
6. Prepare a suitable site to place the batteries.
7. Attach suitable battery lifting device and lift batteries from the machine.

### **⚠ WARNING:**

Batteries are a potential environmental hazard. Consult your battery supplier for safe disposal methods.

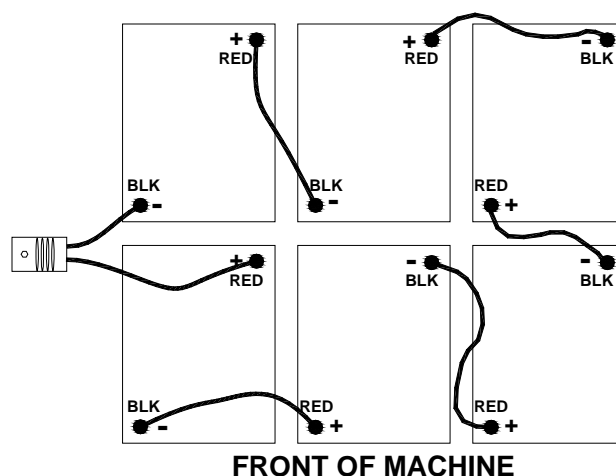

### Squeegee Blades

The front squeegee blade allows solution to pass through channels in the blade into the squeegee assembly while maintaining vacuum to provide lift. The front blade has four wear surfaces and can be rotated for extended life. The front blade should not require regular replacement under normal use.

The rear blade wipes the floor to a near dry condition. It is important the rear blade be in good condition to properly do its job. As with the front, each squeegee blade assembly has four wear surfaces for extended service.

Check both the front and rear squeegee blades for damage, wear, and adjustment each day in the pre-run check. Change the front blade if it is torn or has an uneven edge. Change the rear blade if it is less than 1/2 the original thickness.

### Adjusting Squeegee

Adjusting the squeegee is a two-part process. First, the squeegee assembly must have correct pitch in order for the squeegee blade to have the same deflection at each tip as well as the center. The knob on the squeegee linkage controls the pitch adjustment. The second adjustment is the deflection. Knobs on each end of the squeegee control this.

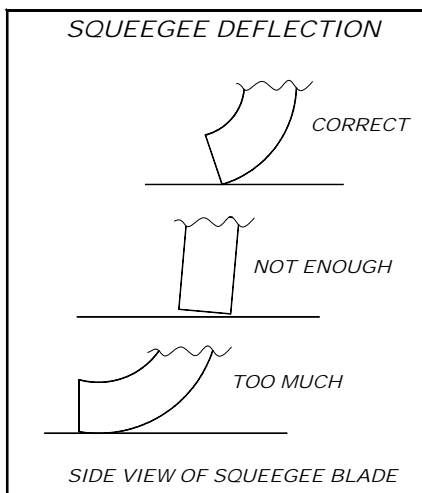

### To Remove Squeegee Assembly

1. With the squeegee in the up position, turn key switch "OFF".
2. Disconnect vacuum hose from squeegee and loosen both knobs.
3. Pull squeegee assembly rearward from the lifting carrier.
4. Inspect or repair as necessary and reinstall.

### To Replace or Rotate Rear Squeegee Blades

1. With the squeegee in the up position, turn key switch "OFF".

**FOR SAFETY: Before leaving or servicing machine; stop on level surface, turn off machine and remove key.**

2. Remove the squeegee assembly from the machine. Unlatch and remove blade retainer strap and remove squeegee blade.
3. Rotate the squeegee to new edge position or replace as required. Each blade has four new edge positions.
4. Install blade on locating pins of squeegee assembly.
5. Install squeegee retainer strap.
6. Fasten and lock latch, adjust latch only tight enough to take up slack in retaining strap.

### To Replace or Rotate Front Squeegee Blades

1. With the squeegee in the up position, turn key switch "OFF".
2. Remove the squeegee from the machine. Loosen three thumbscrews and remove the retainer strap and squeegee blade.
3. Rotate the squeegee to new edge position or replace as required. Each blade has four new edge positions. When installing the front blade, tighten the center thumbscrew first. Insure that the retainer strap is pressed against the blade before tightening the outer screws.



## To Adjust Squeegee Pitch

1. Choose a smooth, level surface. Turn "ON" the key switch. Lower the squeegee and drive forward at least 2 feet (60cm.).
2. With the squeegee down, stop the machine. Do not allow machine to roll back.

**FOR SAFETY: Before leaving or servicing the machine; stop on level surface, turn off machine and remove key.**

3. Determine the differences, if any, in deflection of the squeegee blade between each end and the middle. Proper adjustment is obtained when deflection is equal all the way across the squeegee blade. The bubble level should also indicate when the squeegee is adjusted properly. When the air bubble is in the center of the vial, the deflection should be even across the squeegee blade.
4. To decrease the deflection of the squeegee blade at the ends, tighten knob near the squeegee center. To increase the deflection at the ends of the squeegee assembly, loosen knob.
5. Check the deflection of the squeegee blades again. Repeat steps 1 through 4 until the deflection is equal across the entire rear squeegee blade.

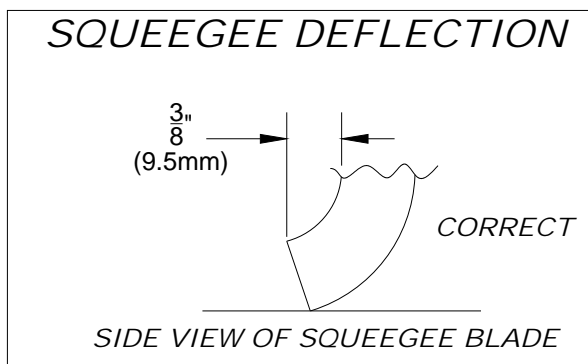

## To Adjust Amount of Rear Squeegee Deflection

1. Choose a smooth, level surface. Lower the squeegee and drive forward at least 2 feet (60cm).
2. With the squeegee down, stop the machine. Do not allow machine to roll back.

**FOR SAFETY: Before leaving or servicing machine; stop on level surface, turn off machine and remove key.**

3. Observe the amount of squeegee deflection. It should deflect 3/8 in. (9.5mm) across the entire width of the squeegee.
4. To increase the squeegee deflection, turn the 2 knobs at the squeegee ends counter-clockwise. To decrease the deflection, turn the knobs clockwise.  
*NOTE: The deflection should be consistent along the length of the squeegee. If the deflection varies from end to end the knobs can be adjusted independently to correct the variation.*
5. Turn on the key switch. Raise, then lower squeegee assembly. Drive forward at least 2 feet (60cm).
6. Repeat steps 2 through 4 until deflection of 3/8 in. (9.5mm) is reached.

## To Replace Aqua-Mizer Squeegee Blades

These squeegee blades have two wear edges. To use the second edge:

1. Remove deck shrouds.
2. Remove brushes or pad drivers.
3. Remove each of the Aqua-Mizer squeegee systems.
4. Remove the hardware from each system that retains the blade.
5. Flip the blades and replace hardware.
6. Re-install each Aqua-Mizer system, brushes or pad drivers and shrouds.

### Scrub Brushes

There are four different types of brushes available to cover applications from cleaning heavily soiled floors to polishing. A pad driver is also available to take advantage of the many cleaning pads on the market. Please refer to the following to assist in selecting the proper brush or pad for the work at hand.

### Uncoated Floors

**Aggressive Grit** is a nylon fiber impregnated with silicone carbide grit. It grinds away stain, soil, and removes surface material.

**Mild Grit** is a less aggressive silicone carbide grit suitable for cleaning medium soil conditions. Advantages are faster ground speed than nylon bristles on light solid applications.

**Polypropylene** is a general-purpose scrub brush with stiff bristles. Polypropylene works well for maintaining concrete, wood and tile floors.

### Finished Floors

**Nylon bristles** are used in a variety of applications on coated or uncoated surfaces.

**White Pads** (Polishing) are used for dry polishing to achieve a high-gloss appearance, or surface washing on highly polished or burnished floors.

**Red Pads** (Buffing) are used for light-duty scrubbing. When used with a mild detergent they will provide surface cleaning without removing the finish.

**Blue Pads** (Scrubbing) are used for heavy-duty scrubbing and light stripping. The blue pads remove less finish than brown stripping pads, yet will remove black marks, stains and dirt.

**Black Pads** (Stripping) are used for easy and complete removal of old floor waxes/finishes. They will quickly remove ground in dirt, black heel marks, and spills. When used with the proper stripper, this pad leaves the floor clean and ready for finishing.

The scrub brushes should be checked before each days work for wire, string, wear and damage.

### Replacing or Installing Scrub Brushes

1. With the scrub deck up, turn "OFF" the machine.

**FOR SAFETY: Before leaving or servicing the machine; stop on level surface, turn OFF machine and remove key.**

2. Remove the brush cover shrouds.
3. Locate release lever on top of brush or pad driver. Rotate release lever counter-clockwise and the brush/pad driver will release and drop down.
4. To reinstall, center the brush driver under the brush drive hub. Raise until it contacts brush driver assembly. Turn clockwise until release lever plate locks into position.
5. Replace the brush cover shrouds.

*NOTE: Check that release plate is completely closed and pad/brush is securely attached. Damage to driver or brush could occur.*

### Recovery Tank Float Shut-Off

When water is no longer being vacuumed from the floor and the vacuum fan is operating, the ball float has engaged. The vacuum motor will not vacuum water with recovery tank full. The recovery tank must be drained.

1. The float shut-off screen can be cleaned in or out of the machine.
2. To clean the float shut-off while it is inside the machine wipe material off screen then rinse. Check that the ball is also clean and moves freely.
3. To remove the float shut-off, grasp the screen with one hand and the connected tube with the other. Tilt and pull the float screen assembly to pull it off the barb on the tube.
4. To install, place one hand on the tube, and then tilt and push the float screen assembly over the barb on the tube.

## Solution Strainer

The solution strainer is located in front of the left front wheel. The solution strainer protects the solenoid valve from debris. If there is little or no solution flow to the ground, check the strainer for debris. Drain the solution tank and clean the solution strainer. To remove the strainer, turn the bottom part of the strainer counter-clockwise until the bottom is separated. Clean out the debris from the wire mesh and re-assemble. Make sure the O-ring gasket is in place when re-assembled.

## Brush Motor

### **WARNING:**

Do not use a pressure washer to clean around the brush motors. Use tap pressure only.

## Changing Brush Motors

1. With the scrub deck in the stored position, disconnect brush motor wiring connector from harness.
2. Remove shrouds from scrub deck to access and remove scrub brushes or pad drivers.
3. Remove retaining bolt, lock washer, flat washer and star drive from brush motor shaft.
4. Remove 4 brush motor mounting bolts located under scrub deck.
5. Remove brush motor.
6. Reverse steps to install.

## Brush Motor Carbon Brush Replacement

1. Scribe alignment mark on motor barrel to motor cap. Remove two bolts.
2. Remove end cap from motor.  
*NOTE: Motors contain two wave washers in cap. Do not lose these.*
3. Release brush from spring tension. Remove screw connecting brush wire lead to brush holder. Clean brush holder to insure free movement.
4. Retract spring and install new brush. Install connector screw and lead.
5. When all new brushes are installed. Place all in retracted position, held into brush holder by spring tension.
6. Carefully place end cap onto bearing on motor shaft.  
*NOTE: Use care to assure wave washer alignment.*
7. With end cap in partially installed position, release all brushes to contact position with motor commutator.  
*NOTE: Failure to insure all brushes are released will result in motor failure.*
8. Reset end cap and realign with scribe marks on motor barrel. Reinstall the two attach bolts from cap into base.
9. Maintain alignment between motor barrel base and cap.

## Traction Motor

### **⚠ WARNING:**

Do not use a pressure washer to clean around the motors. Use tap pressure only.

## Traction Motor Carbon Brush Replacement

**FOR SAFETY: Before leaving or servicing machine, stop on a level surface, turn off machine and remove key.**

1. Disconnect batteries from machine.
2. Disconnect the electrical connection to the traction motor.
3. Remove brush cap.
4. Release brush from spring tension. Remove screw connecting brush wire lead to brush holder. Clean brush holder to insure free movement.
5. Install new brush and reinstall connecting screw and lead.
6. When all new brushes are installed. Place all in retracted position, held into brush holder by spring tension.
7. Carefully replace brush cap onto bearing on motor shaft.

## Circuit Breakers

Circuit breakers interrupt the flow of power in the event of an electrical overload. When a circuit breaker is tripped, reset it by pressing the exposed button. If a circuit breaker continues to trip, the cause of the electrical overload should be found and corrected.

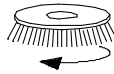

30 Amp. Protects the left scrub brush motor.

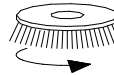

30 Amp. Protects the right scrub brush motor.



25 Amp. Protects the vacuum motor.



25 Amp. Protects the propel motor.



3 Amp. Protects the machine controls.

## Brush Shroud & Brush Skirts

Contain the water in the shroud area. The skirt will flex over uneven floors and also as the brush or pad wears. As the brush wears the shrouds can be adjusted so that skirt does not have to flex so much.

Remove three bolts on each side that fasten the bracket to the cover and re-assemble in the top holes. When the brushes are replaced with new ones move the covers back to the lower set of holes.

## Vacuum Motor

(Refer to the Vacuum Group in the parts section of manual)

### **⚠ WARNING:**

Do not use a pressure washer to clean around the vacuum motors. Use tap pressure only. Care must be taken so that water is not directed into vacuum motor air intakes.

## CHANGING VACUUM MOTOR

1. Disconnect batteries from machine.
2. Remove front cover.
3. Disconnect electrical connector to the vacuum motor.
4. Loosen clamp and disconnect hose from vacuum intake.
5. Remove vacuum motor mounting bracket bolts.
6. Remove vacuum motor from mounting bracket.
7. Reverse steps to install.

### Vacuum Motor Carbon Brushes Replacement (Windsor)

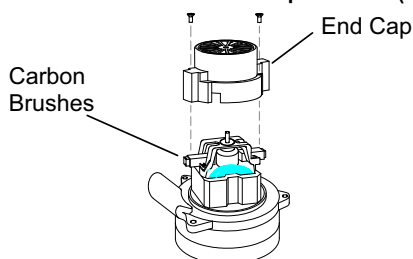

If armature commutator is grooved, extremely pitted or not concentric, the motor will need to be replaced or sent to a qualified service center.

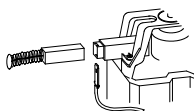

#### **Important:**

These brushes wear quicker as the length shortens due to increased heat. Spring inside brush housing will damage motor if brushes are allowed to wear away completely.

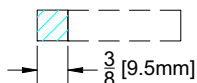

Periodically check the length of the carbon brushes. Replace both carbon brushes when either is less than 3/8" (9.5mm) long.

### Vacuum Motor Carbon Brushes Replacement (Ametek)

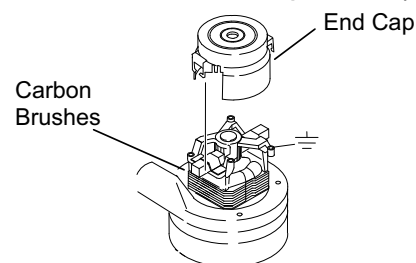

If armature commutator is grooved, extremely pitted or not concentric, the motor will need to be replaced or sent to a qualified service center.

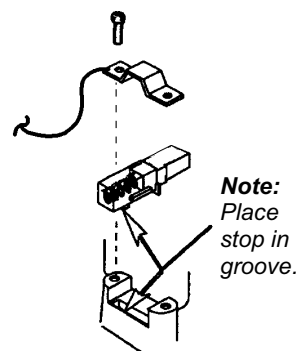

#### **Important:**

These brushes wear quicker as the length shortens due to increased heat. Spring inside brush housing will damage motor if brushes are allowed to wear away completely.

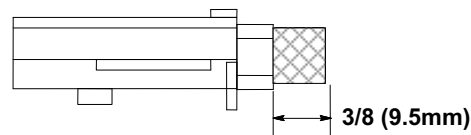

Periodically check the length of the carbon brushes. Replace both carbon brushes when either is less than 3/8" (9.5mm) long.

**Greasing Axle**

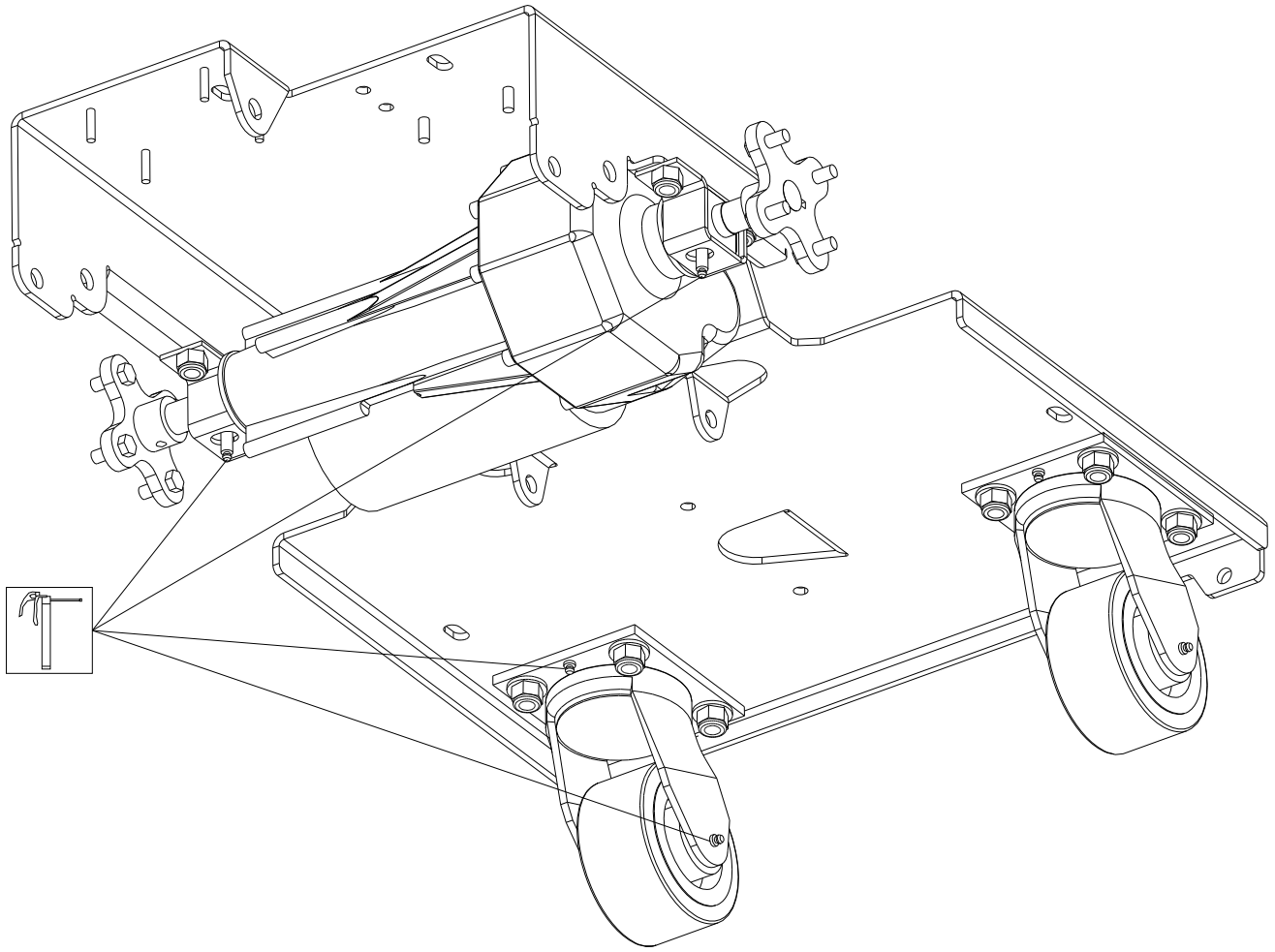

**RECOMMENDED GREASING:**  
1-2 strokes of Mobiltemp®78 or compatible clay-based  
or calcium-based grease.  
**NOTE:** Use hand operated grease gun only.

## Machine Troubleshooting

PROBLEM	CAUSE	SOLUTION
Poor or no water pick-up	Squeegee out of adjustment	Adjust squeegee
	Debris caught on squeegee	Remove debris
	Worn squeegee blades	Rotate or replace squeegee blades
	Vacuum hose clogged	Clear obstruction from hose
	Vacuum hose disconnected from squeegee or recovery tank	Reconnect vacuum hose
	Vacuum hose damaged	Replace vacuum hose
	Recovery tank not sealed	Place recovery tank dome on tank. Replace damaged gaskets.
	Foam filling recovery tank	Empty recovery tank Use less or different detergent Use defoamer
Vacuum motor does not run, or runs slowly	Recovery tank full	Drain recovery tank
	Recovery tank float system dirty	Clean float system
	Circuit breaker tripped	Reset circuit breaker
	Loose connection	Check motor wires and connections
	Faulty vacuum switch	Replace switch
	Worn vacuum motor brushes	Replace brushes, check commutator
Poor scrubbing performance	Debris caught in scrub brushes	Remove debris
	Worn brushes or pads	Replace brushes or pads
	Improper detergent, brush or pad used	Contact equipment or application specialist
	Low scrub brush down pressure	Increase brush pressure
	Low battery charge	Charge batteries
Brush motors do not run, or runs slowly	Circuit breaker(s) tripped	Reset circuit breaker(s)
	Loose connection	Check motor wires and connection
	Faulty brush motor contactor	Replace contactor
	Worn brush motor brushes	Replace brushes, check commutator

**Machine Troubleshooting**

<b>PROBLEM</b>	<b>CAUSE</b>	<b>SOLUTION</b>
Little or no solution flow to the floor	Solution tank empty	Fill solution tank
	Solution flow turned off or set too low	Turn on or increase flow setting
	Solution strainer plugged	Clean solution strainer
	Solution hoses obstructed	Clear obstruction from hose
	Solution solenoid valve obstructed or stuck	Clean or replace
No power to machine	Vent hole in solution tank lid obstructed	Clear obstruction from vent hole
	Battery disconnected	Check all battery cable connections
	Emergency shut-off activated (If included)	Reset
	Battery connections corroded	Clean connections
	Faulty main contactor	Replace contactor
Little or no propel	Faulty key switch	Replace switch
	Low battery charge	Charge batteries
	Wheels spin	Decrease brush pressure
	Controller overheated	Allow cool down period Adjust brush shroud if needed
	Loose connection	Check motor wires and connection





*Notes:*

---

# PARTS

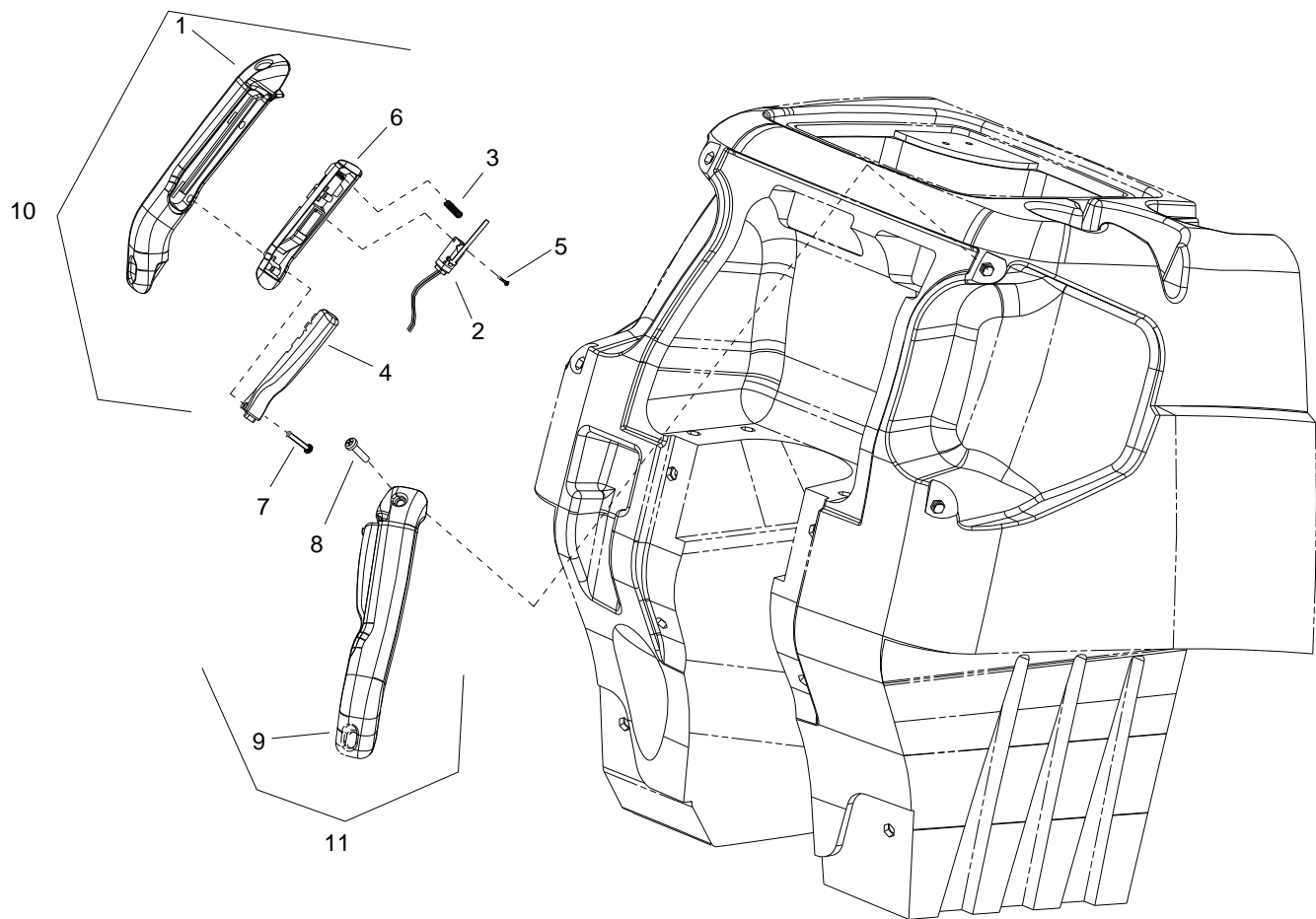

REF	PART NO.	QTY	DESCRIPTION	SERIAL NO. FROM	NOTES
1	86238730	1	HANDLE, LEFT		
2	86257230	2	SWITCH, SPST MOM NO W/LEVER		
3	86254920	2	SPRING, COMP .24ODX1.25X.018		
4	86231480	2	BUTTON, PROPEL		
5	86277070	2	SCREW, 4-40 X .625 PHPNHMS STL ZNPLT		
6	86240990	2	HOUSING, BUTTON		
7	86277060	4	SCREW, 8-32 X .875 PHPNHTC		
8	86277050	4	SCREW, 5/16-18 X .75 SCHCS SS		
9	86238740	1	HANDLE, RIGHT		
10	86004120	-	PROPEL HANDLE ASM LEFT		SERVICE ONLY
11	86004130	-	PROPEL HANDLE ASM RIGHT		SERVICE ONLY

Cover (Front) & Tank Mount

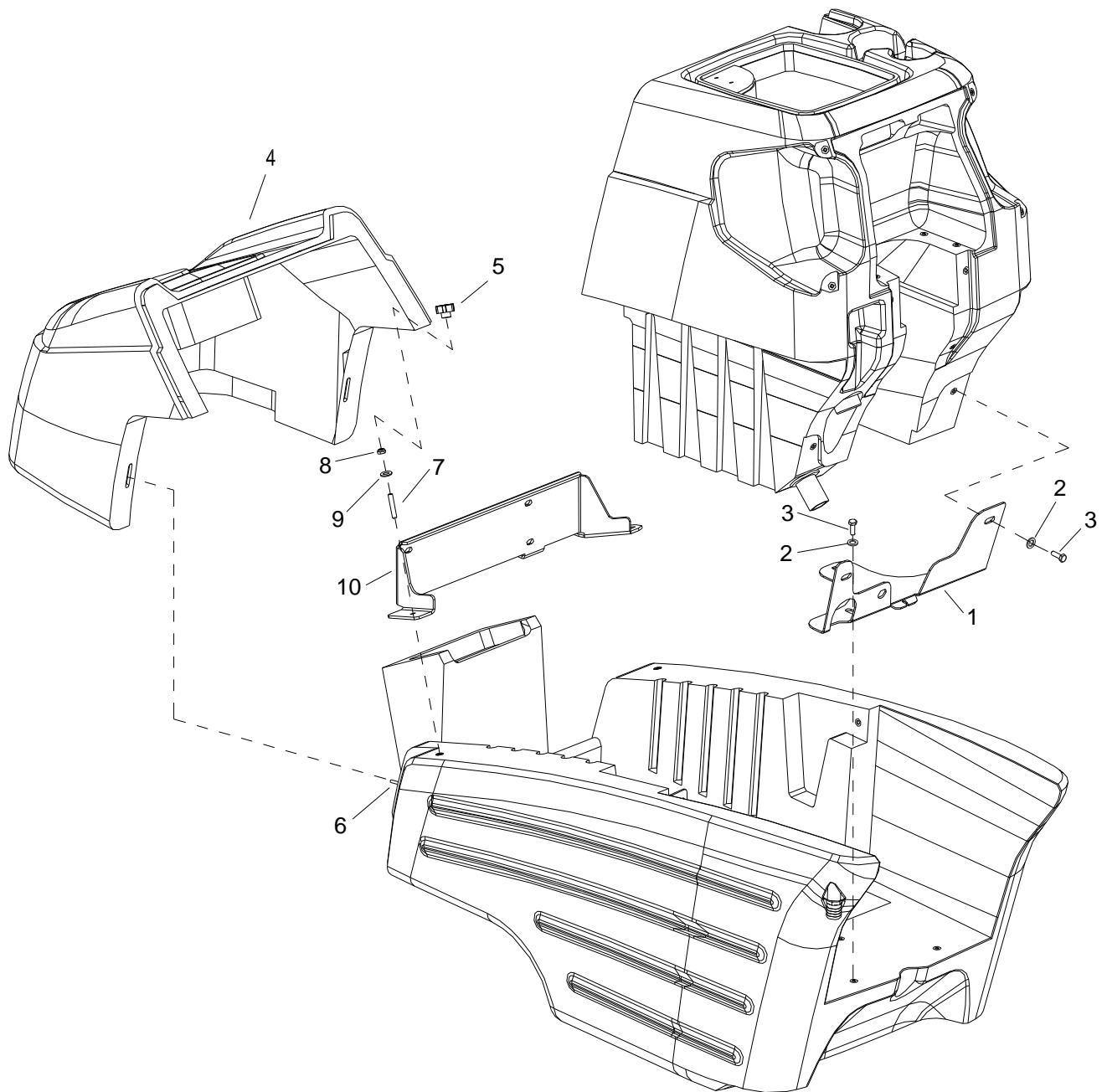

REF	PART NO.	QTY	DESCRIPTION	SERIAL NO. FROM	NOTES
1	86073690	2	BRT, REC TO SOL W/BRAKE 36V		
2	86010670	2	WASHER 5/16 FLAT SS		
3	86276780	5	SCREW, 5/16-18 X .75 HHCS SS		
4	86062550	1	COVER, FRONT, 36V, GRY		
5	86377890	2	KNOB, 1.36" DIA X 5/16-18		
6	86276380	4	SCREW, 5/16-18 X 1.25 SCHSET CP SS		
7	86279630	3	WASHER, 5/16 X 1.13 X .09 FLT		
8	86065990	1	ARM, TANK SUPPORT		
9	86010720	1	WASHER, M10 X 30 X 2.5 FNDR ZNPLT		
10	86276920	1	SCREW, 3/8-16 X 1 HHCS SS NP		

Cover (Top) & Tank Mount

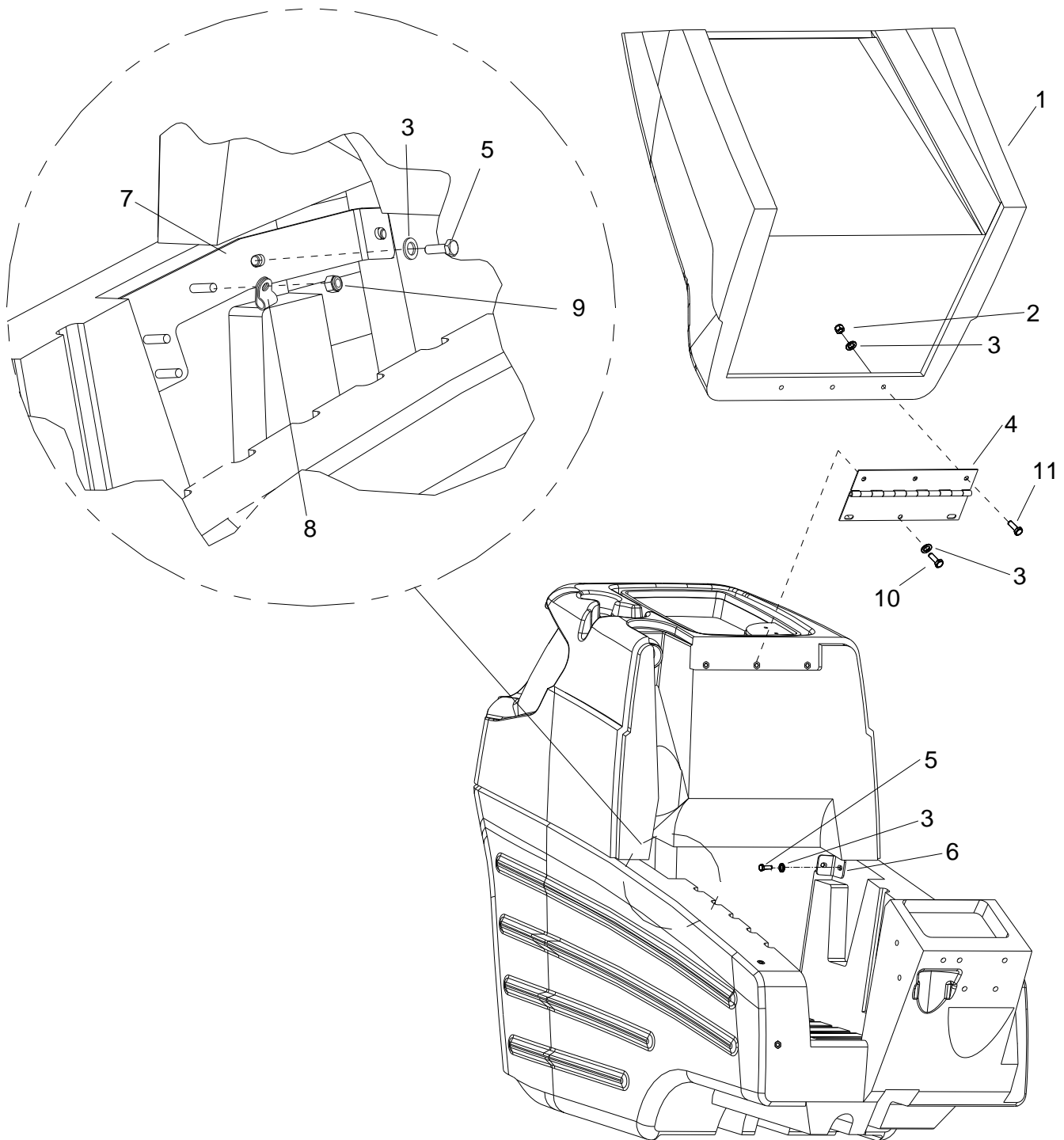



REF	PART NO.	QTY	DESCRIPTION	SERIAL NO. FROM	NOTES
1	86062560	1	COVER, TOP, 36V, GRY		
2	86271840	3	NUT 5/16-18 HEX NYLOCK THIN SS		
3	86010670	10	WASHER 5/16 FLAT SS		
4	86239650	1	HINGE, COVER TO TANK 36V		
5	86276780	4	SCREW, 5/16-18 X .75 HHCS SS		
6	86069840	1	BRKT, TANK LEFT 36V		
7	86069850	1	BRKT, TANK RIGHT, 36V		
8	86233390	1	CLAMP, 7/8 DIA "P~CUSHIONED		
9	86271870	1	NUT, 1/4-20 HEXTHIN NYLOCK SS		
10	86276490	3	SCREW, 5/16-18 X .625 HHCS SS		
-	86292630	1	NET, CARGO		NOT SHOWN
11	86276780	3	SCREW, 5/16-18 X .75 HHCS SS		

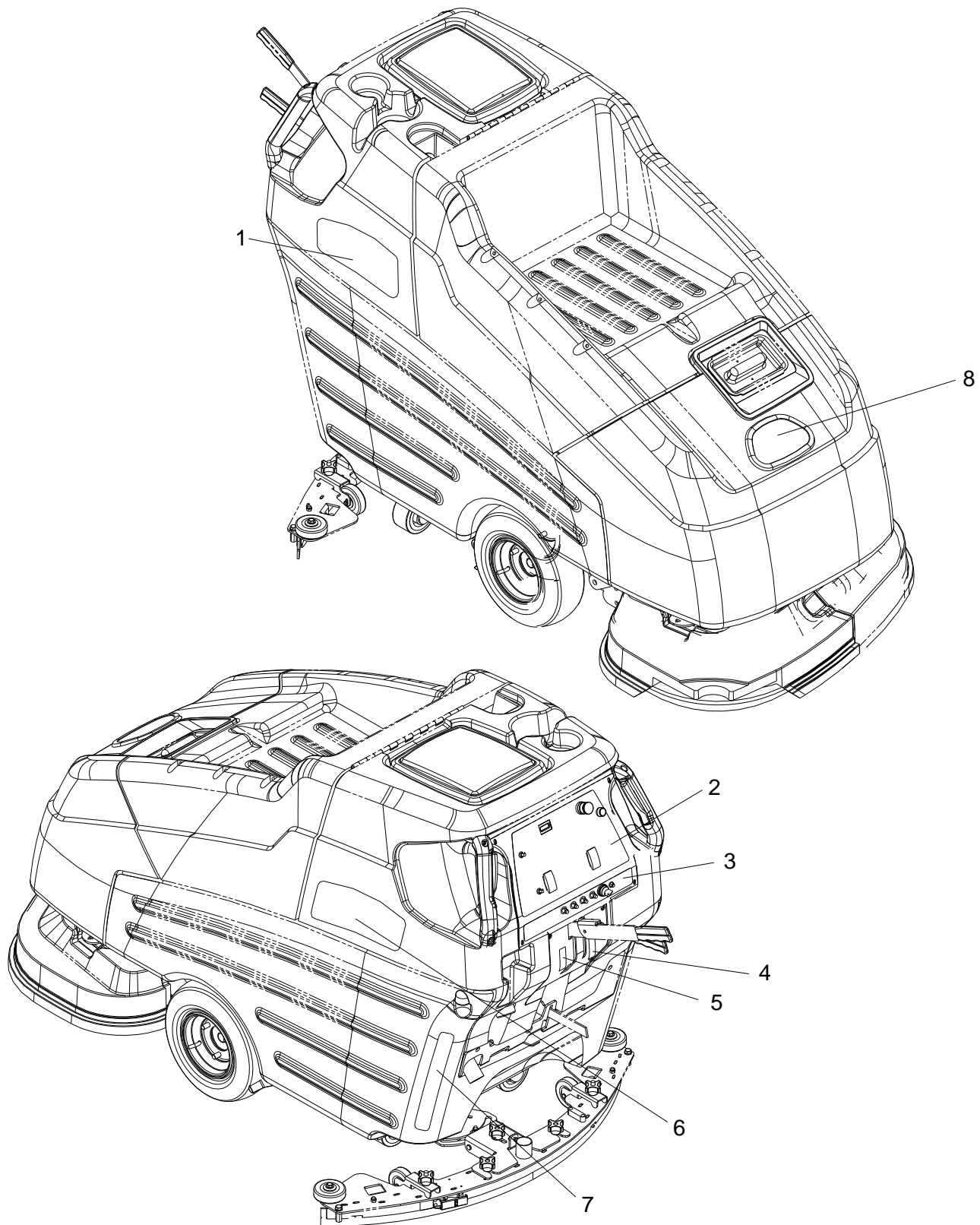

REF	PART NO.	QTY	DESCRIPTION	SERIAL NO. FROM	NOTES
1	86243560	1	LABEL, CUTTER RIGHT		
2	86243620	1	LABEL, ELEC. PANEL 36V BASIC		
3	86243610	1	LABEL, ELECT PANEL, LOWER 36V		
4	86243600	1	LABEL, SQUEEGEE LEVER		
5	86243590	1	LABEL, BRUSH LEVER		
6	86243550	1	LABEL, CUTTER LEFT		
7	86243710	1	LABEL, SOLUTION FILL 36V		
8	86004970	1	LABEL WINDSOR LOGO DOMED		

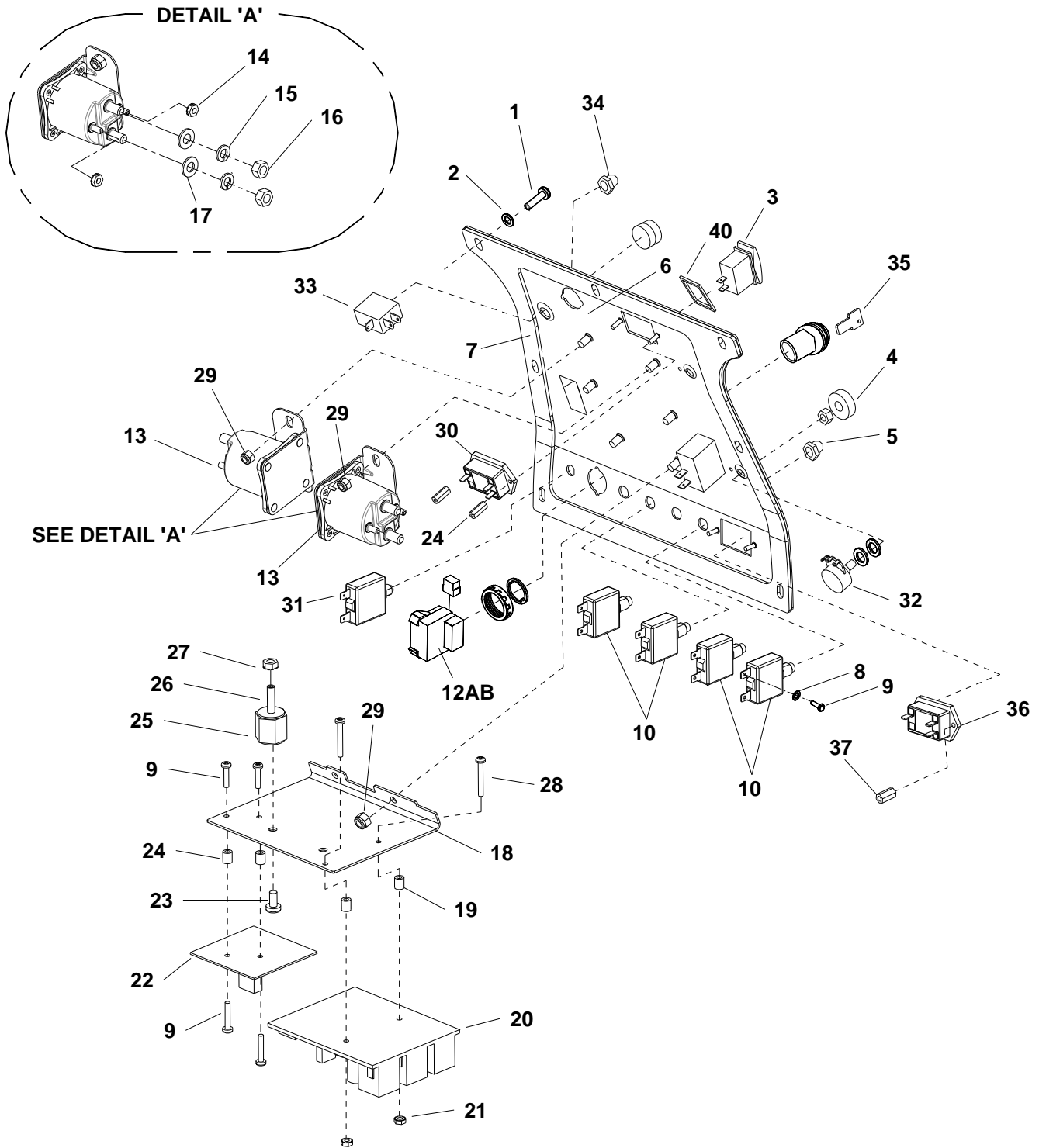

REF	PART NO.	QTY	DESCRIPTION	SERIAL NO. FROM	NOTES
1	86276290	7	SCREW, 10 X .75 PHPNHMS BLK ZNPLT		
2	86294250	7	WASHER, .19ID X .5 X .09TK BLK		
3	86007140	2	SWITCH SPST 2-POSITION ROCKER		
4	86242110	2	KNOB, .90OD X .25 COLLET		
5	86008900	4	BOOT, SEAL-PUSH BUTTON 7/16-28		
6	86082850	1	PLATE, ELEC. PANEL, 36V BASIC		
7	86237820	1	GASKET, ELEC. PANEL, 36V		
8	86279300	8	WASHER, 6 X .25 X .031 SPL SS		
9	86273990	12	SCREW, 6-32 X .375 PHPNHMS SS		
10	86001910	4	BREAKER, 30A 50VDC CIRCUIT		
11	-	-	-		
12A	86007170	1	SWITCH KEY TWO POSITION		
12B	86193750	-	SW,RTRY NON-ILLUM TM		OPTIONAL
13	86371450	2	RELAY 36VDC 100AMP HD		
14	86005700	4	NUT, 10-32 HEXSTRW LK STL ZNPLT		
15	86279480	4	WASHER, 5/16 X .588 X .028 EXTLK		
16	86271120	4	NUT, 5/16-18 BRASS		
17	86010760	2	WASHER, 5/16 X .688 X .065 FLT STL ZNPLT		
18	86082820	1	PLATE, ELECT. PANEL, BACK		
19	86254440	2	SPACER,.166IDX.313ODX.375L AL		
20	86002940	1	CONTROLLER, 36VDC PROPEL MOTOR		
21	86270850	2	NUT, 8-32 HEX NYLOCK SS		
22	86003250	1	CIRCUIT BOARD SOL FLOAT WIRED		
23	86276880	1	SCREW, 1/4-20 X .375 HHCS SS		
24	86255890	2	STANDOFF, 6-32 X 1.0 HEX NYL		
25	86255910	1	STANDOFF, 1/4-20 X 1.0 HEX INS		
26	86006850	1	SCREW, 1/4-20 X 1.25 SCHSET CP SS		
27	86005710	1	NUT, 1/4-20 HEXSTRW LK STL ZNPLT		
28	86273910	2	SCREW, 8-32 X 1 PHPNHMS SS		
29	86271870	6	NUT, 1/4-20 HEXTHIN NYLOCK SS		
30	86246930	1	METER,36V BATTERY CHARGE LEVEL		
31	86002000	1	BREAKER, 3 AMP 1681-090-300		
32	86006310	1	POTENTIOMETER, 50K OHMS		SERVICE ONLY
33	86257030	1	SWITCH, MOMENTARY DPST		
34	86002010	1	BOOT, 3/8 CIRCUIT BREAKER		
35	86004860	1	KEY, SWITCH		SERVICE ONLY
36	86005530	4	METER, 12-48 VDC LED HOUR	1000096610	
37	86255900	1	STANDOFF, 6-32 X 5/8 HEX NYL	1000099610	
38	86267340	2	WIRE, 22" RED/18 76040 X 76075	1000099610	NOT SHOWN
39	86267360	1	WIRE, 14" BLK/18 76011 X 76040	1000099610	NOT SHOWN
40	86238030	2	GASKET, SWITCH CARLING		

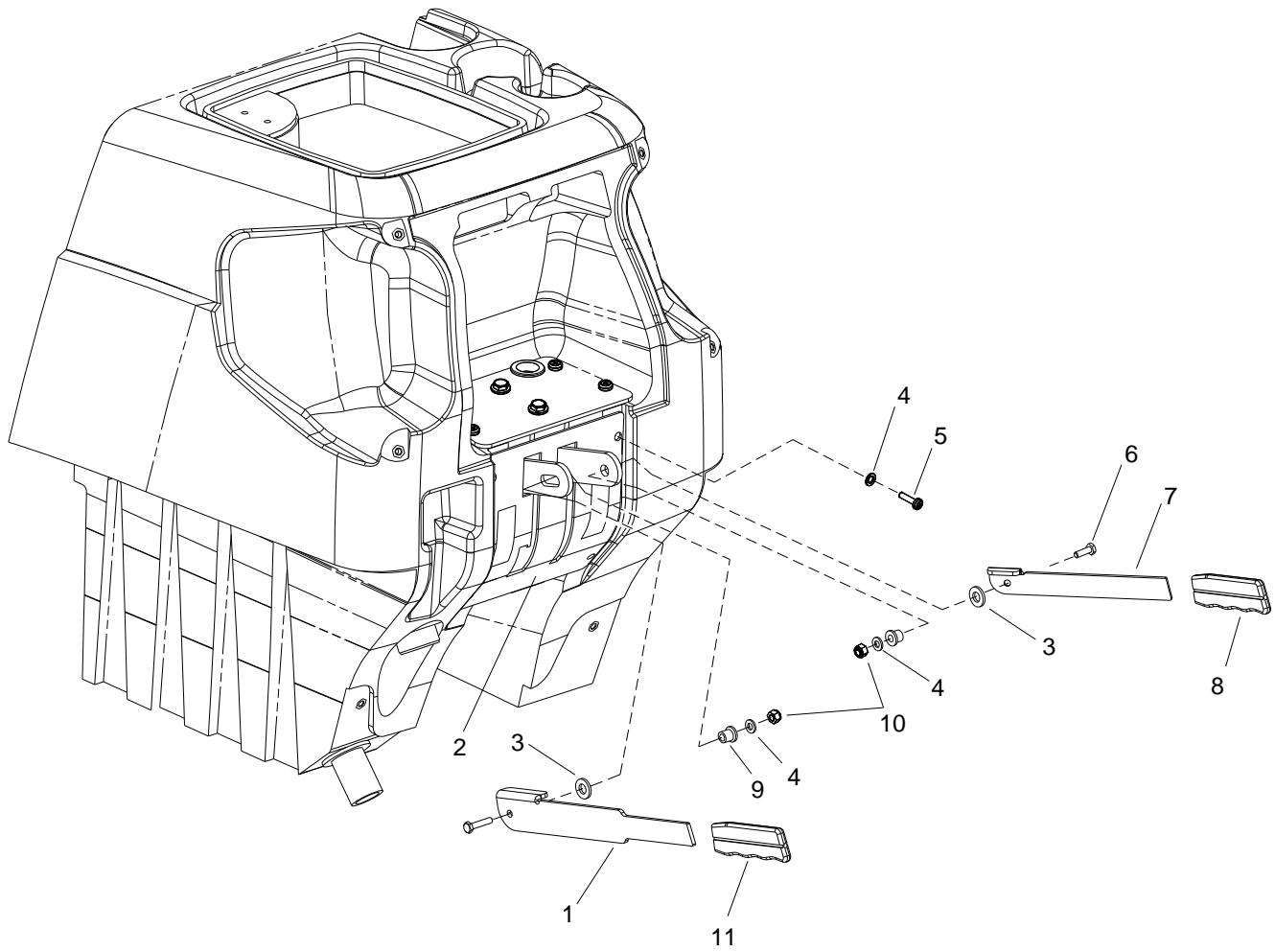

REF	PART NO.	QTY	DESCRIPTION	SERIAL NO. FROM	NOTES
1	86077260	1	LEVER, DECK SWING		
2	86082900	1	PLATE LEVER NOTCH BASIC 36V		
3	86259400	2	WASHER THRUST.51 ID X 1 ODBRO		
4	86010670	6	WASHER 5/16 FLAT SS		
5	86276780	4	SCREW, 5/16-18 X .75 HHCS SS		
6	86006930	2	SCREW, 5/16-18 X 1 SCHBTNHCS SS		
7	86066860	1	BAR, SQG LIFT SWING 36V		
8	86238360	1	GRIP, 3/16 X 1.0 ORANGE		
9	86228840	2	BUSHING, .314 X .502 X .5 FLG		
10	86271840	2	NUT 5/16-18 HEX NYLOCK THIN SS		
11	86238350	1	GRIP, 3/16 X 1.0 BLUE		

# Lift Handle Linkage

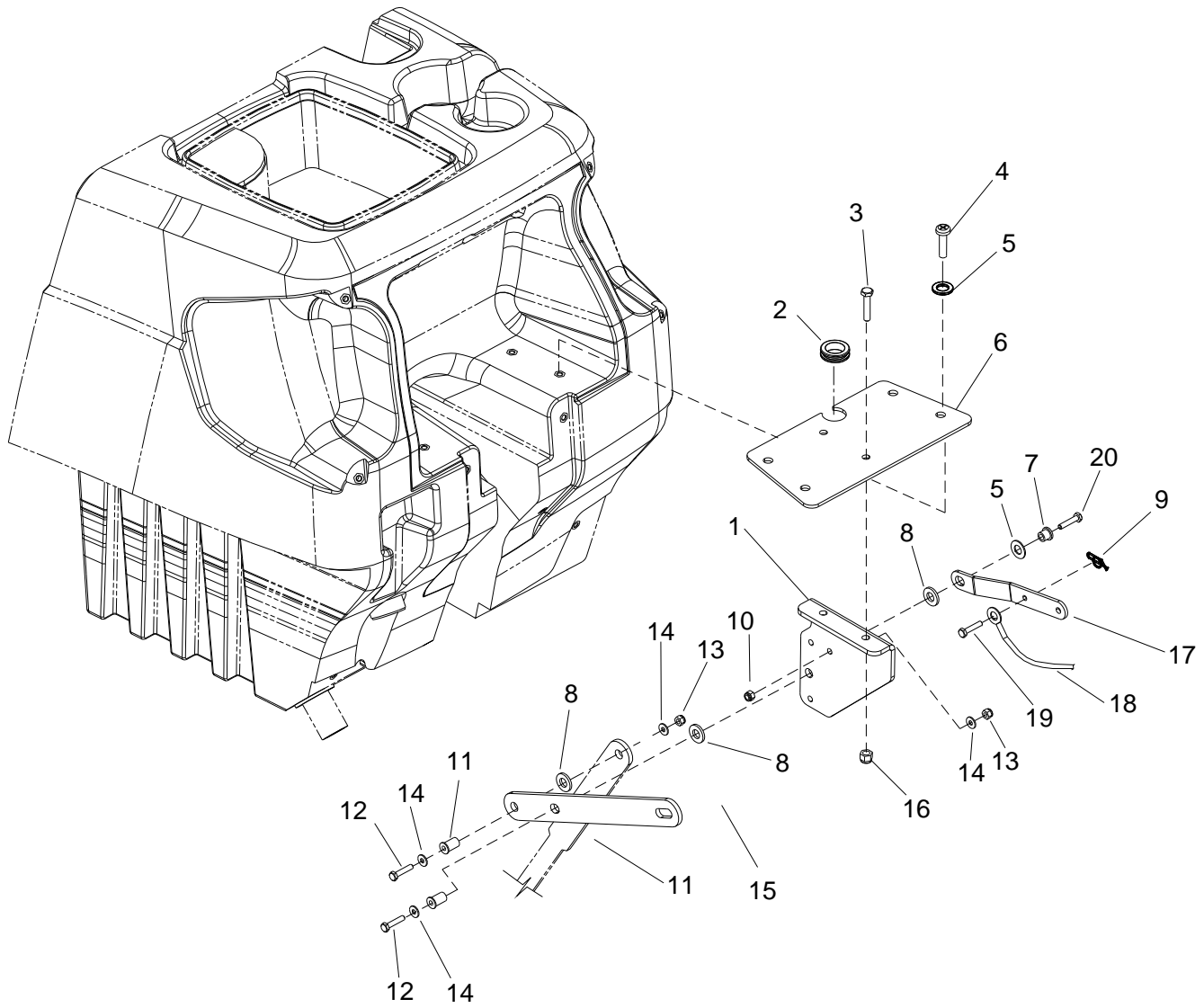



REF	PART NO.	QTY	DESCRIPTION	SERIAL NO. FROM	NOTES
1	86069830	1	BRKT, LEVER, PIVOT BOTTOM 36V		
2	86238430	1	GROMMET 1.00 ID 3/16 GRIP		
3	86276920	2	SCREW, 3/8-16 X 1 HHCS SS NP		
4	86276780	5	SCREW, 5/16-18 X .75 HHCS SS		
5	86010670	5	WASHER 5/16 FLAT SS		
6	86082890	1	PLATE, PIVOT TOP		
7	86228840	1	BUSHING, .314 X .502 X .5 FLG		
8	86259400	3	WASHER THRUST.51 ID X 1 ODBRO		
9	86008650	1	COTTER, 1/4" RING		
10	86271840	2	NUT 5/16-18 HEX NYLOCK THIN SS		
11	86228900	2	BUSHING, .252 X .503 X .75 FLG		
12	86273820	2	SCREW, 1/4-20 X 1.25 HHMS SS		
13	86271870	2	NUT, 1/4-20 HEXTHIN NYLOCK SS		
14	86010630	4	WASHER, 1/4 X .625 FLT SS		
15	86066840	1	BAR, DECK LIFT FIXED, 36V		
16	86005630	2	NUT, 3/8-16 HEXTHIN NYLOCK SS		
17	86077210	1	LEVER SQG LIFT FIXED		
18	86003240	1	CABLE .125X26.5,0707,SS,LB,E-E		
19	86009560	1	PIN, CLEVIS 1/4 X .625 STL ZNPLT		
20	86007020	1	SCREW, 5/16-18 X 1.25 HHCS SS NP		
21	86006560	1	SCREW, 5/16-18 X 1 HHCS SS NP		

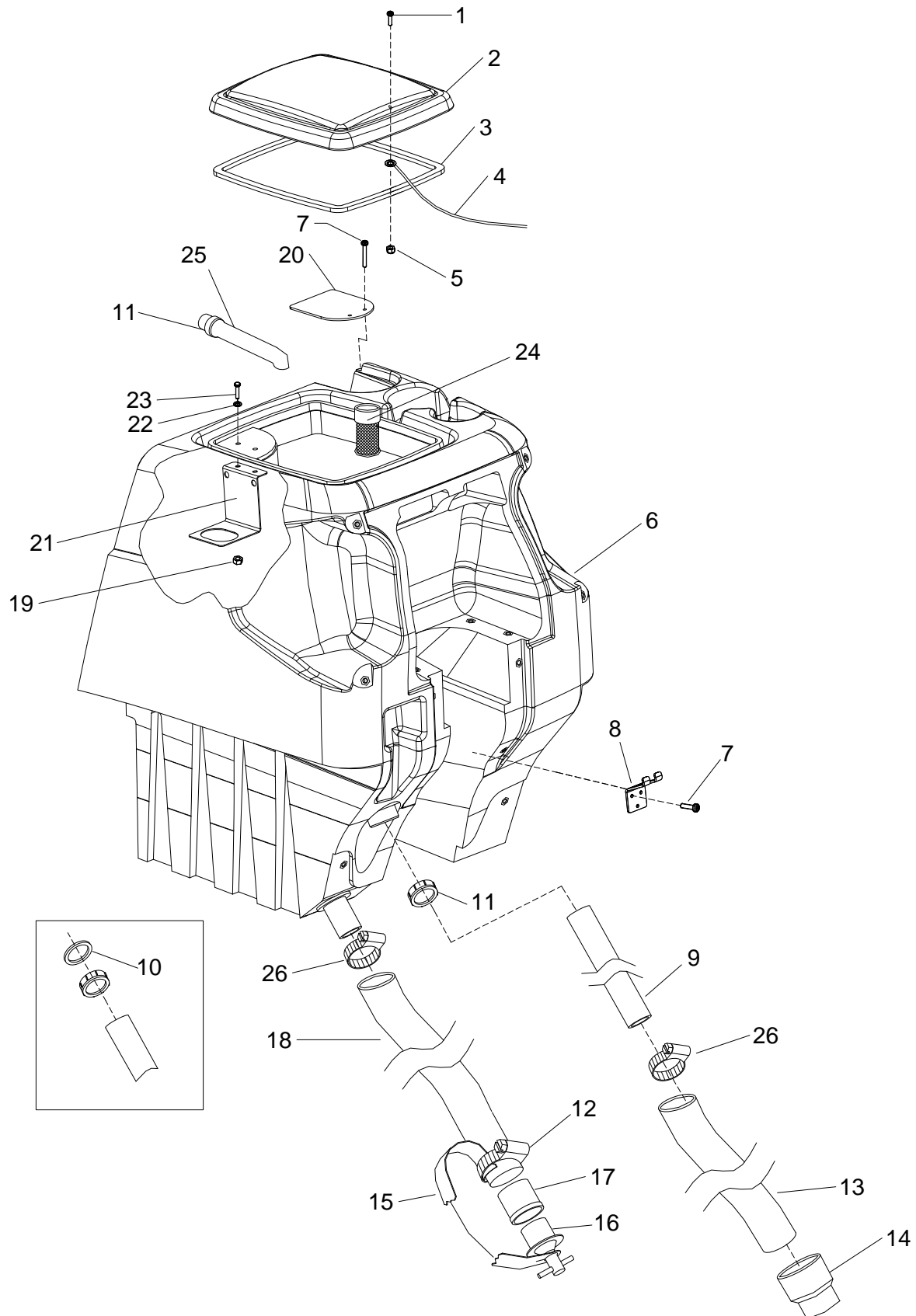

REF	PART NO.	QTY	DESCRIPTION	SERIAL NO. FROM	NOTES
1	86273950	1	SCR, 6-32 X 1/2 PPHMS SS		
2	86003340	1	DOME, 13 X 11		
3	86003990	1	GASKET, DOME		
4	86246080	1	LANYARD, 18.0 W/ LOOP & EYE		
5	86270920	1	NUT, 6-32 HEX NYLOCK SS		
6	86032560	1	TANK REC, 36V,GRY		
7	86276290	5	SCREW, 10 X .75 PHPNHMS BLK ZNPLT		
8	86001190	1	BRACKET, RECOVERY HOSE MTG		
9	86089630	1	TUBE, 1.5 PVC X 24.0		
10	86237650	2	GASKET, 1 1/2 COMPRESSION		
11	86372080	2	NUT 1.5 SLIP JOINT		
12	86002400	1	CLAMP, 2.0" WORM GEAR X .312W		
13	86004180	1	HOSE 1.5 BLK VAC X 28"		
14	86002840	1	CUFF, 1.5 SLIP X 1.5 HOSE		
15	86008400	1	TETHER, DRAIN PLUG		
16	86006240	1	DRAIN PLUG 1 1/4"		
17	86004450	1	HOSEBARB, 1.5 DOUBLE MCHD		
18	86004260	1	HOSE 1.5 X 24.0 DRAIN		
19	86271870	2	NUT, 1/4-20 HEXTHIN NYLOCK SS		
20	86075540	1	COVER, VACUUM HOSE		
21	86069780	1	BRKT, VAC INTAKE		
22	86010630	2	WASHER, 1/4 X .625 FLT SS		
23	86273810	2	SCREW, 1/4-20 X 1 HHCS SS		
24	86236410	1	FLOAT VAC SHUT OFF		
25	86257860	1	TUBE, 1.5 WASTE		
26	86233140	2	CLAMP, 2.0" WORM GEAR		



REF	PART NO.	QTY	DESCRIPTION	SERIAL NO. FROM	NOTES
1	86000290	2	PAD DRIVER, 16" SD		
2A	86000300	2	BRUSH 16" POLYPROPYLENE SD		
2B	86000310	2	BRUSH 16" NYLON SD		
2C	86000320	2	BRUSH 16" NYLON POLISH SD		
2D	86000330	2	BRUSH 16" MILD GRIT SD		
2E	86000340	2	BRUSH 16" SUPER AGGRESSIVE SD		
3	86005070	1	LOCK PAD CENTER SNAP,TWO STEP		
4	86276590	3	SCREW, 12-11 X 1 PHPNHSMS SS TYPEA		
5	86276580	4	SCREW, 8-32 X .75 PHTRHMS SS		
6	86276600	3	SCREW, 10-12 X .75 PHTRHSMS SS TYPEA		
7	86007910	1	SPRING EXT .31D X 2.0L X .03W		
8	86007280	1	SOCKET, DRIVE BRUSH		
9	86005940	1	PLATE BRUSH RELEASE		

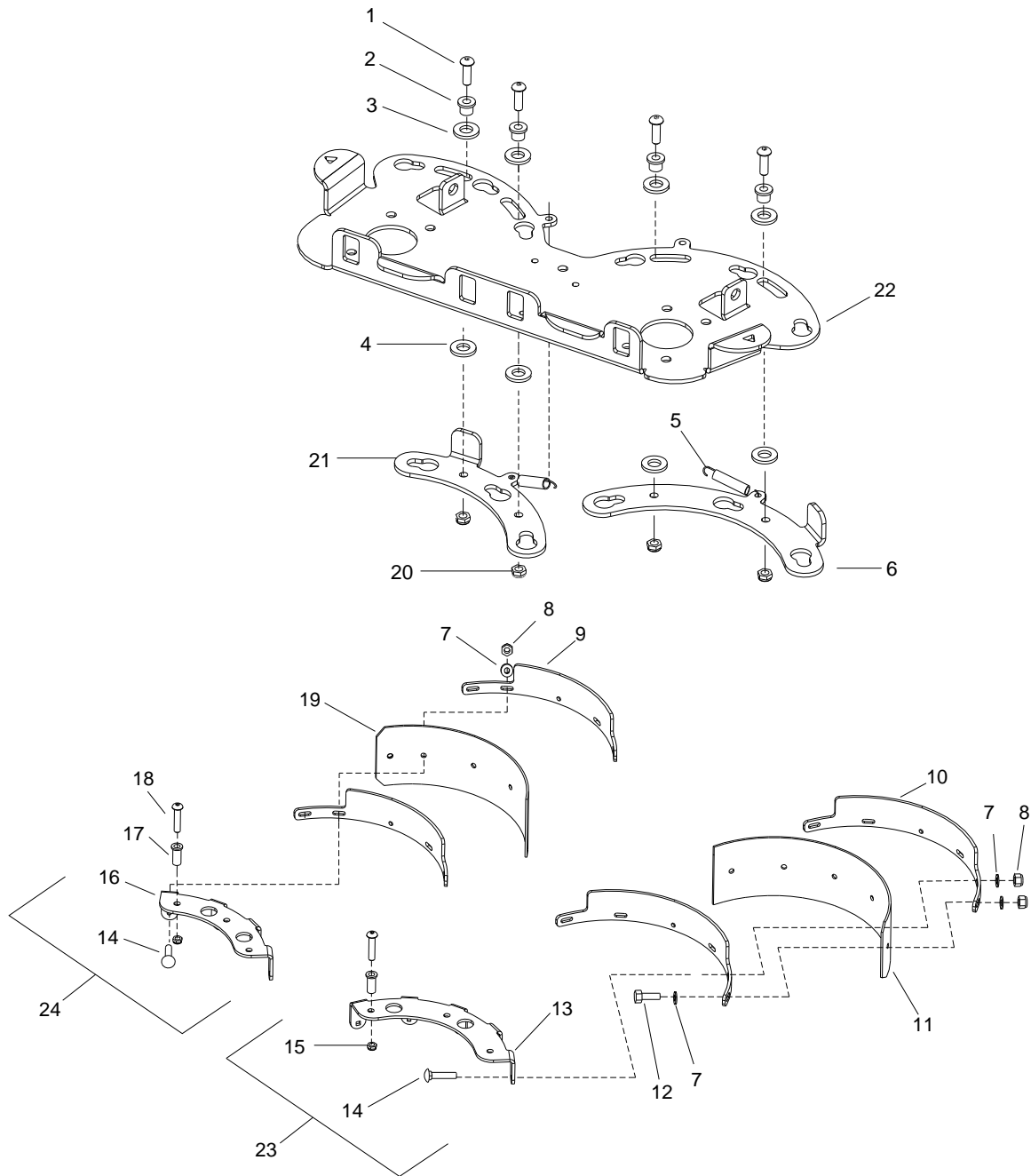

REF	PART NO.	QTY	DESCRIPTION	SERIAL NO. FROM	NOTES
1	86006930	4	SCREW, 5/16-18 X 1 SCHBTNHCS SS		
2	86228840	4	BUSHING, .314 X .502 X .5 FLG		
3	86259420	4	WASHER, .510 X 1 X .093 THR		
4	86259400	4	WASHER THRUST .51 ID X 1 OD BRO		
5	86255060	2	SPRING, EXT .43D X2.50L X.047W		
6	86249590	1	PLATE, AQ LOCK LEFT 16 IN		
7	86010630	13	WASHER, 1/4 X .625 FLT SS		
8	86271870	11	NUT, 1/4-20 HEXTHIN NYLOCK SS		
9	86256020	2	STRAP, AQ, BACK, R 16 INCH		
10	86256010	2	STRAP, AQBACK, L 16 INCH		
11A	86001430	1	BLADE AQ LEFT 16 INCH		
11B	86135160	1	BLADE, AQ LT 16 INCH URETHANE		
12	86273810	2	SCREW, 1/4-20 X 1 HHCS SS		
13	86082870	1	PLATE, AQ ATTACH L, 16	"	
14	86276960	9	SCREW, 1/4-20 X 1 CARR SS		
15	86005630	6	NUT, 3/8-16 HEXTHIN NYLOCK SS		
16	86082880	1	PLATE, AQ, ATTACH R 16 IN		
17	86228910	6	BUSHING, .377 X .502 X 1.25 FLG BRZ		
18	86276860	6	SCREW, 3/8-16 X 1.75 SCHBTNHCS SS		
19A	86001420	1	BLADE AQ RIGHT 16 INCH		
19B	86135170	1	BLADE, AQ RT 16 INCH URETHANE		
20	86082380	4	NUT, 5/16-18 HEX NYLOCK THIN SS		
21	86249600	1	PLATE, AQ LOCK RIGHT 16 IN		
22	86236670	1	FRAME, 36V SCRUB DECK		
23	86024960	-	AQUA-MIZER 32 IN SCRUBHEAD LT		SERVICE ONLY
24	86004700	-	AQUA-MIZER 32IN SCRUBHEAD RT		SERVICE ONLY

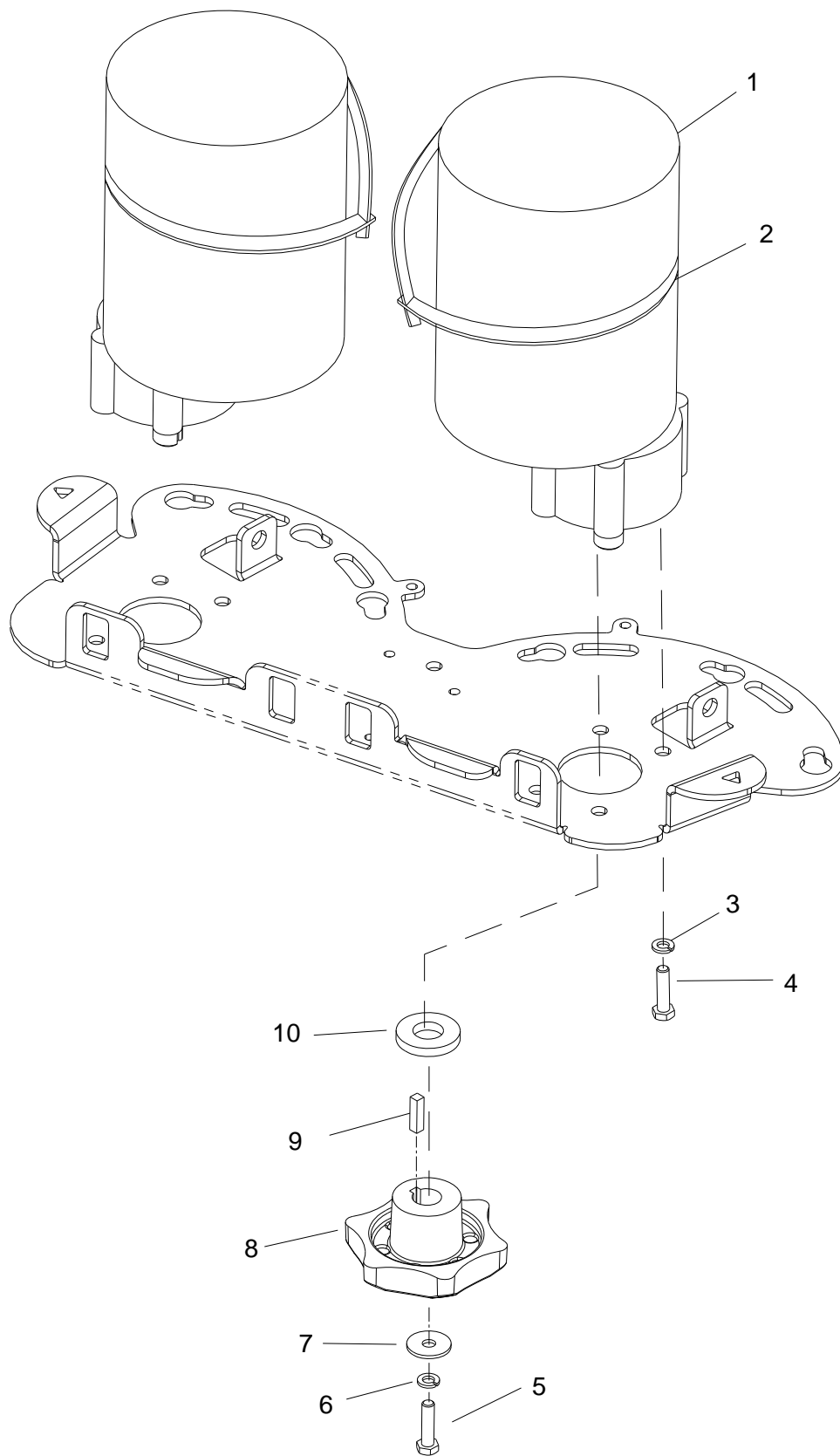



REF	PART NO.	QTY	DESCRIPTION	SERIAL NO. FROM	NOTES
1	86005340	2	MOTOR 36VDC 200RPM 3/4HP GEAR		
2	86002830	2	CABLE TIE .375 X 24.7		
3	86010790	8	WASHER, 3/8 X .680 X .094 SPL STL ZNPLT		
4	86276970	8	SCREW, 3/8-16 X .75 HHCS SS		
5	86007020	2	SCREW, 5/16-18 X 1.25 HHCS SS NP		
6	86279130	2	WASHER, 5/16 X .583 X .078 SPL STL ZNPLT		
7	86279630	2	WASHER, 5/16 X 1.13 X .09 FLT		
8	86003420	2	DRIVER, BRUSH SD		
9	86004810	2	KEY, 1/4 X 1/4 X 1 LCSTL		
10	86279640	2	WASHER, .780 X 1.63 X .25 FLT YW ZNPLT		

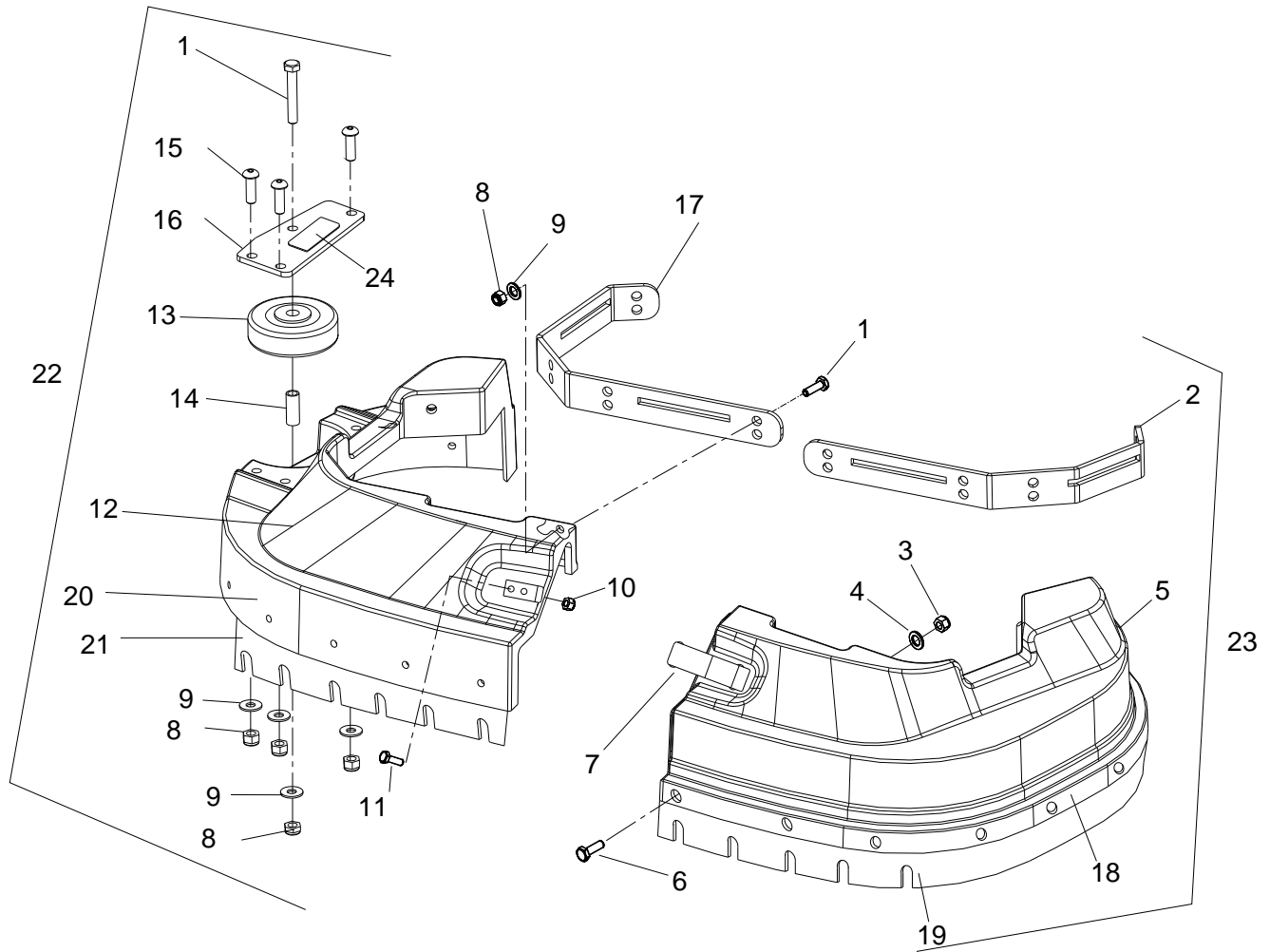

REF	PART NO.	QTY	DESCRIPTION	SERIAL NO. FROM	NOTES
1	86006930	11	SCREW, 5/16-18 X 1 SCHBTNHCS SS		
2	86070050	1	BRKT, SHROUD RETAINER LEFT	1000094309	
3	86271900	19	NUT, 10-24 HEXTHIN NYLOCK SS		
4	86010650	19	WASHER, 10 X .562 X .032 FLT STL PSVT		
5	86022470	1	SHROUD, SCRUBDECK 32 IN (RAW)		
6	86277110	19	SCREW, 10-24 X .75 PHPNHMS SS	1000094309	
7	86161800	1	LATCH & CONCEALED KEEPER		
8	86271840	1	NUT 5/16-18 HEX NYLOCK THIN SS	1000094309	
9	86292500	12	WASHER, 5/16 X .562 X .063 FLT STL PSVT		
10	86270920	4	NUT, 6-32 HEX NYLOCK SS		
11	86273950	4	SCR, 6-32 X 1/2 PPHMS SS	1000094309	
12	86062970	1	SHROUD, SCRUB DECK 32 IN RIGHT		
13	86011020	1	WHEEL 3" DIA CUSHION RUBBER		
14	86001350	1	BUSHING, SPANNER .435 X 1.10		
15	86277150	1	SCREW, 5/16-18 X 2 SCHBTNHCS SS	1000094309	
16	86082950	1	PLATE, BUMPER WHEEL ATTACH	1000094309	
17	86070040	1	BRKT, SHROUD RETAINER RIGHT		
18	86066410	1	BAND, SKIRT LEFT 32 INCH		
19	86007530	1	SKIRT 32 INCH LEFT		
20	86066400	1	BAND, SKIRT RIGHT 32 INCH		
21	86007540	1	SKIRT 32 INCH RIGHT		
22	86004710	-	SHROUD ASM 32" RIGHT SCRUBHEAD		SERVICE ONLY
23	86004720	-	SHROUD ASM 32" LEFT SCRUBHEAD		SERVICE ONLY
24	86244100	1	LABEL, AQUA-MIZER		

# Scrub Deck Lift Linkage

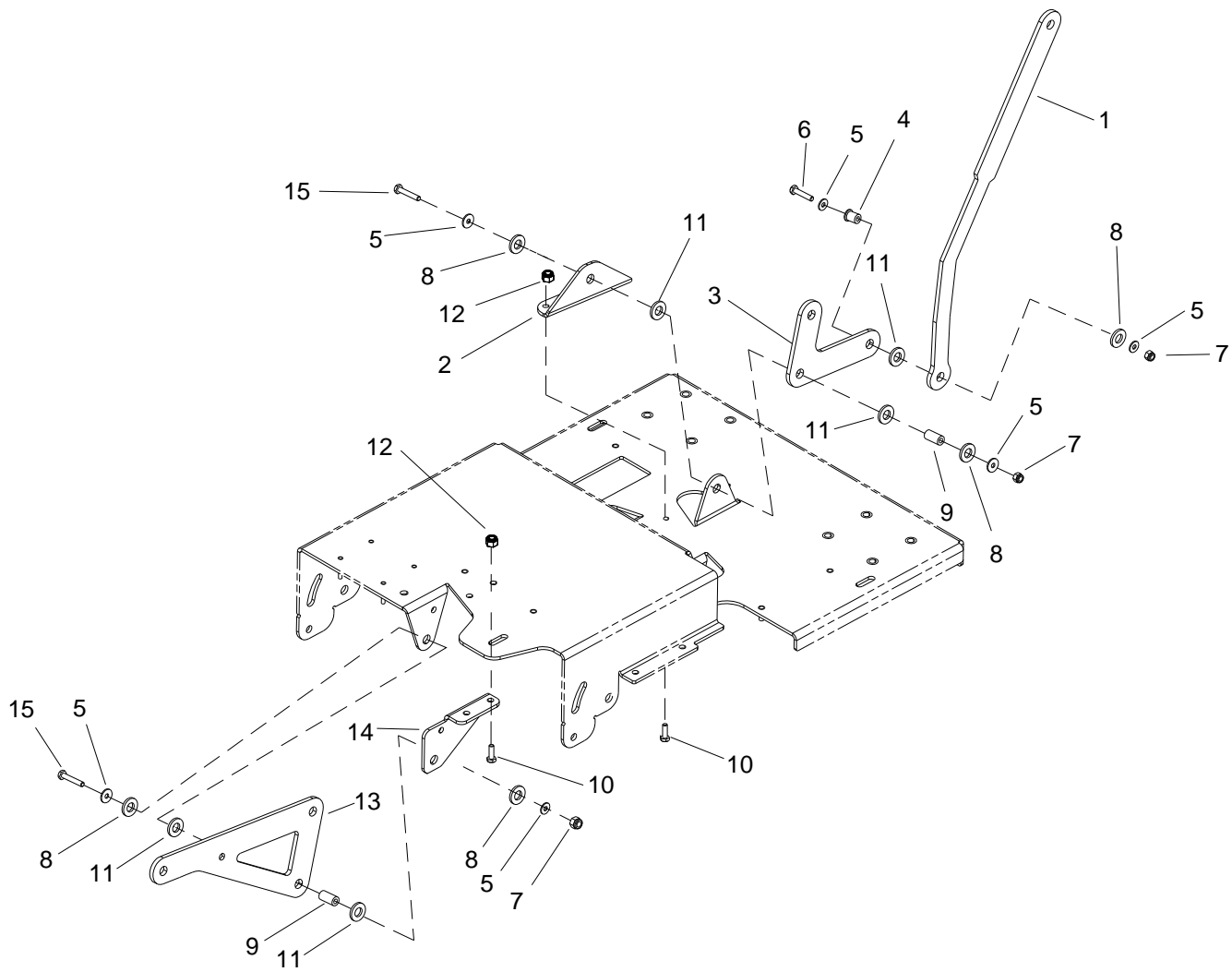

REF	PART NO.	QTY	DESCRIPTION	SERIAL NO. FROM	NOTES
1	86066820	1	BAR VERT. LINKAGE, REAR		
2	86070000	1	BRKT, BELLCRANK SPRT. REAR 36V		
3	86066830	1	BAR, DECK LINKAGE, REAR		
4	86228900	1	BUSHING, .252 X .503 X .75 FLG		
5	86010630	6	WASHER, 1/4 X .625 FLT SS		
6	86273820	1	SCREW, 1/4-20 X 1.25 HHMS SS		
7	86271870	3	NUT, 1/4-20 HEXTHIN NYLOCK SS		
8	86259410	5	WASHER, .510 X 1 X .063 THR		
9	86228920	2	BEARING,.252 ID X.503 ODX.1.0		
10	86276780	4	SCREW, 5/16-18 X .75 HHCS SS		
11	86259400	5	WASHER THRUST.51 ID X 1 ODBRO		
12	86271840	4	NUT 5/16-18 HEX NYLOCK THIN SS		
13	86066800	1	BAR, LINKAGE, FRONT		
14	86070010	1	BRKT, FRAME MOUNT 36V		
15	86273740	2	SCREW, 1/4-20 X 1.5 HHCS SS		

# Scrub Deck Lift Linkage

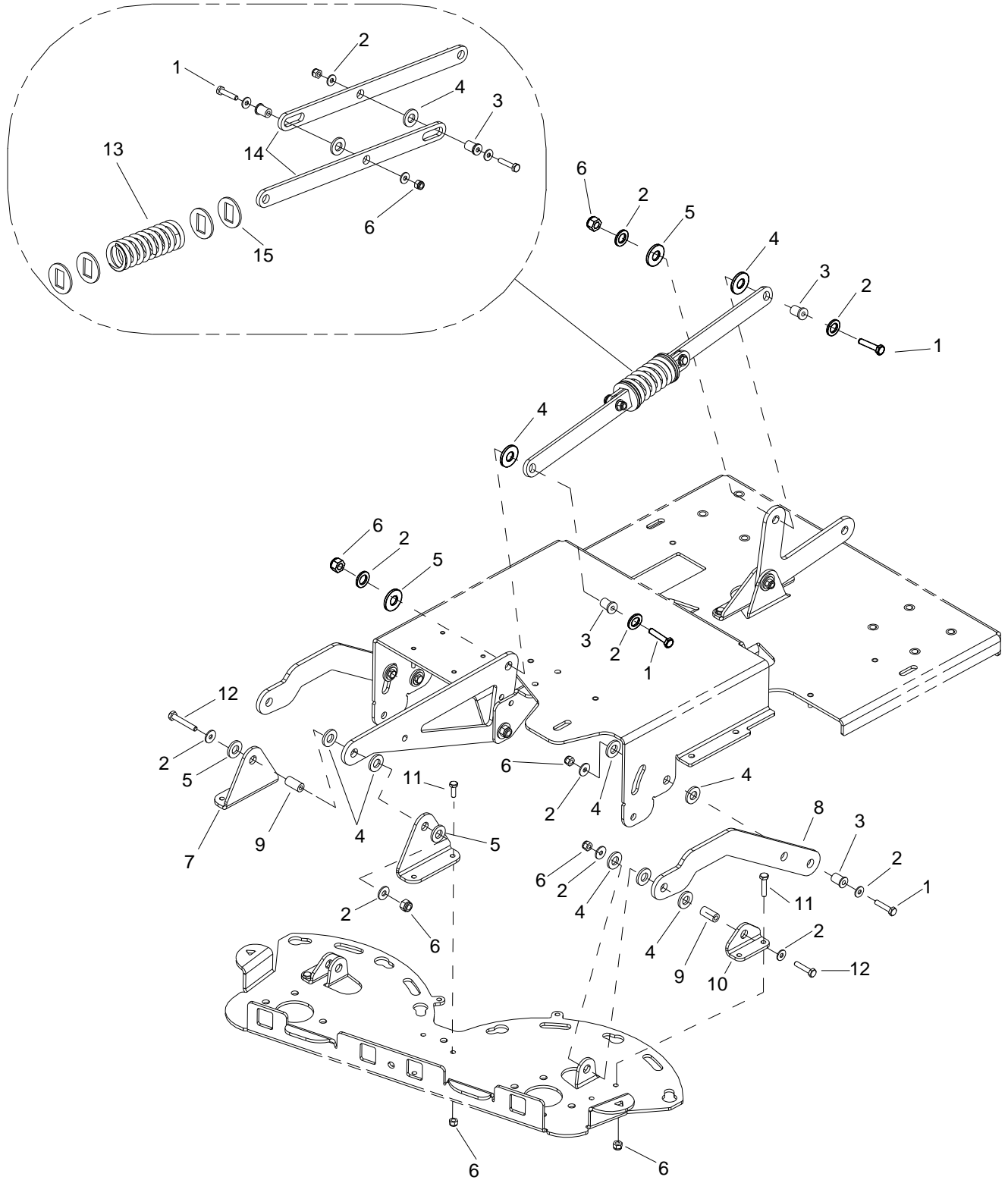

REF	PART NO.	QTY	DESCRIPTION	SERIAL NO. FROM	NOTES
1	86273820	7	SCREW, 1/4-20 X 1.25 HHMS SS		
2	86010630	24	WASHER, 1/4 X .625 FLT SS		
3	86228900	8	BUSHING, .252 X .503 X .75 FLG		
4	86259400	20	WASHER THRUST.51 ID X 1 ODBRO		
5	86259410	6	WASHER, .510 X 1 X .063 THR		
6	86271870	18	NUT, 1/4-20 HEXTHIN NYLOCK SS		
7	86070200	1	BRKT, SCRUB DECK LIFT, R.H.		
8	86066850	2	BAR, LINKAGE RIGHT		
9	86228920	4	BEARING, .252 ID X .503 OD X 1.0		
10	86070030	2	BRKT, ANGLE SUPPORT 36V		
11	86273780	8	SCREW, 1/4-20 X .75 HHCS SS NP		
12	86273740	4	SCREW, 1/4-20 X 1.5 HHCS SS		
13	86254880	1	SPRING,COMP 1.687ODX4.5LX.234W		
14	86066760	2	BAR, TENSIONER		
15	86090270	4	WASHER, RECTANGULAR HOLE		
16	86070210	1	BRKT, SCRUB DECK LIFT, L.H.		
17	86276610	1	SCREW, 1/4-20 X 1.25 PHPNHMS SS		

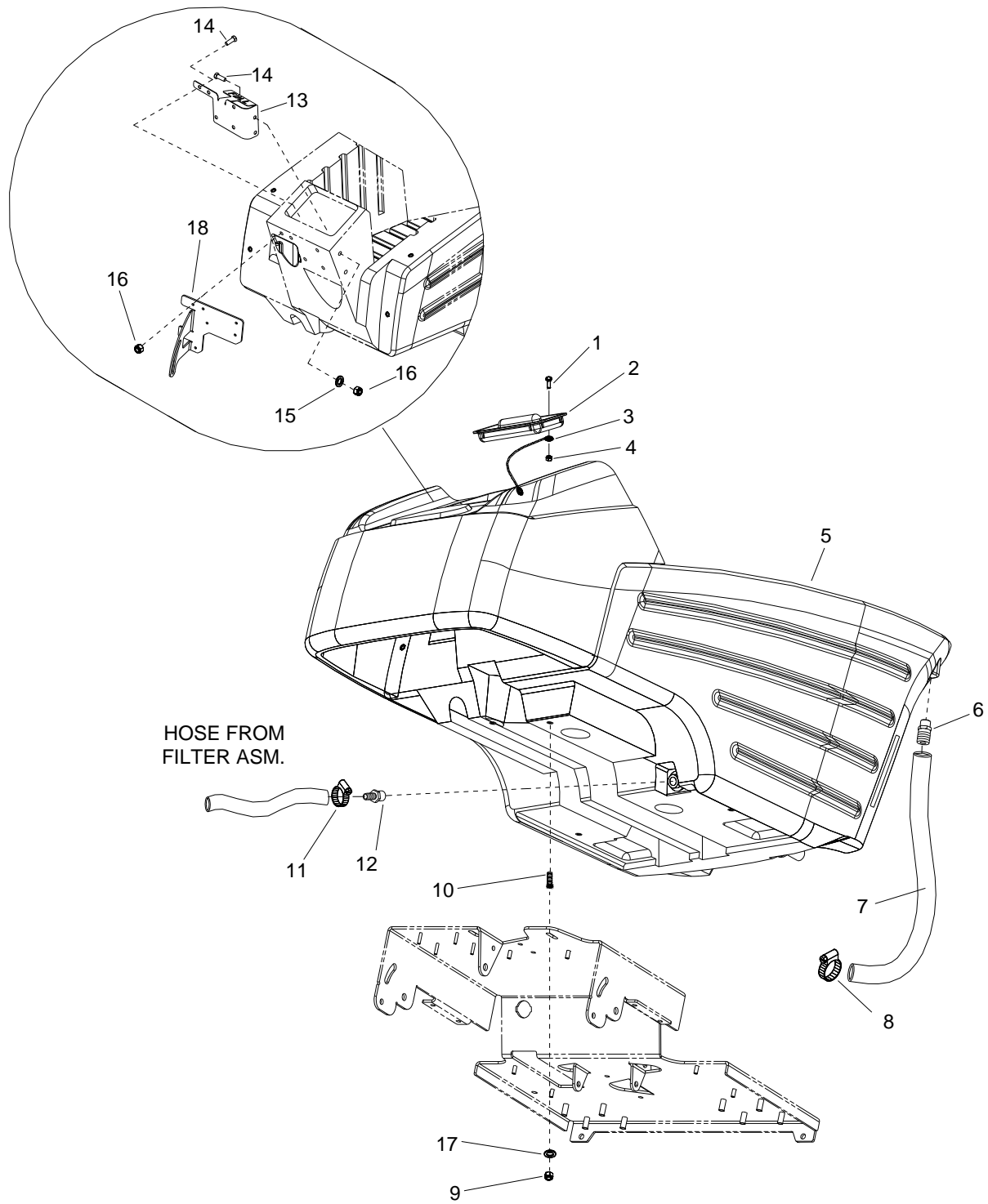



REF	PART NO.	QTY	DESCRIPTION	SERIAL NO. FROM	NOTES
1	86273950	1	SCR, 6-32 X 1/2 PPHMS SS		
2	86234790	1	COVER, CLP SOLUTION		
3	86246080	1	LANYARD, 18.0 W/ LOOP & EYE		
4	86014810	1	NUT, 6-32 ACORN SS		
5	86032550	1	TANK SOL, 36V, BLU		
6	86240460	1	HOSEBARB 1/2MPT X 1.0 HOSE		
7	86282050	1	HOSE 1ID X .12W CLR X 24.5"		
8	86233110	1	CLAMP, 1.0" WORM GEAR		
9	86271840	4	NUT 5/16-18 HEX NYLOCK THIN SS		
10	86276380	4	SCREW, 5/16-18 X 1.25 SCHSET CP SS		
11	86233150	1	CLAMP, 3/8 HOSE (D-SLOT)		
12	86197910	1	HOSEBARB 1/2 MPT X 1/2 POLY DL		
13	86070090	1	BRKT, SOLUTION FILL 36V		
14	86276920	7	SCREW, 3/8-16 X 1 HHCS SS NP		
15	86278910	2	WASHER, 3/8 X .875 X .05 FLT SS		WAS 87003
16	86005630	7	NUT, 3/8-16 HEXTHIN NYLOCK SS		
17	86010670	4	WASHER 5/16 FLAT SS		
18	86070190	1	BRKT, SCRUB DECK GUIDE 36V		

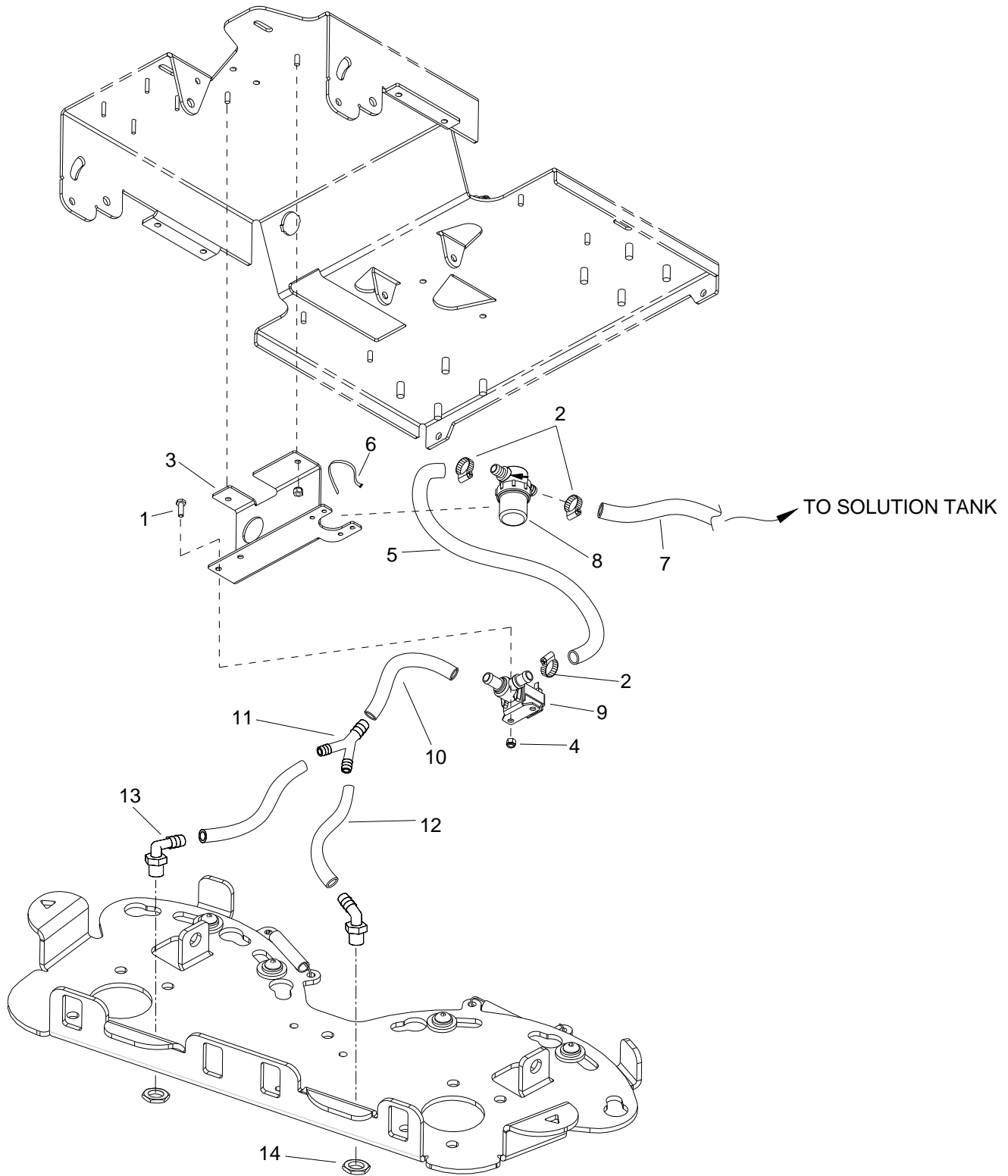

REF	PART NO.	QTY	DESCRIPTION	SERIAL NO. FROM	NOTES
1	86273750	2	SCREW, 1/4-20 X .625 HHCS SS NP		
2	86233150	3	CLAMP, 3/8 HOSE (D-SLOT)		
3	86070020	1	BRKT, FLTR/SOLND MOUNT 36V		
4	86271870	4	NUT, 1/4-20 HEXTHIN NYLOCK SS		
5	86282190	1	HOSE, 1/2ID WIRE BOUND X 13"		
6	86264940	2	CABLE TIE 11.38" UL/CSA		
7	86271690	2	NUT, 10-24 JT CONN BLK		
8	86007560	1	STRAINER 1/2 HOSE 20 MESH		
-	86005870	-	O-RING SEAL FILTER RON-VIK		SERVICE ONLY
-	86007750	-	SCREEN, 20 MESH STRAINER SCRBR		SERVICE ONLY
-	86002860	-	CAP STRAINER 26/32		SERVICE ONLY
9	86009710	1	VALVE 36VDC SOL.1/2" HOSEBARB		
-	86003460	-	PROTECTION PART SRVC PART SLND		SERVICE ONLY
-	86136820	-	SERVICE SLND SPRG KIT		SERVICE ONLY
10	86281100	1	HOSE 1/2ID WIRE BOUND X 7"		
11	86003580	1	FITTING, 1/2" X 3/8 X 3/8 RED. T		
12	86280820	2	HOSE 3/8ID NYLOBRD X 10"		
13	86001550	2	HOSEBARB, 3/8MPT X3/8 90D		
14	86240280	1	HOSE, 1/2ID WIRE BOUND X 8"		

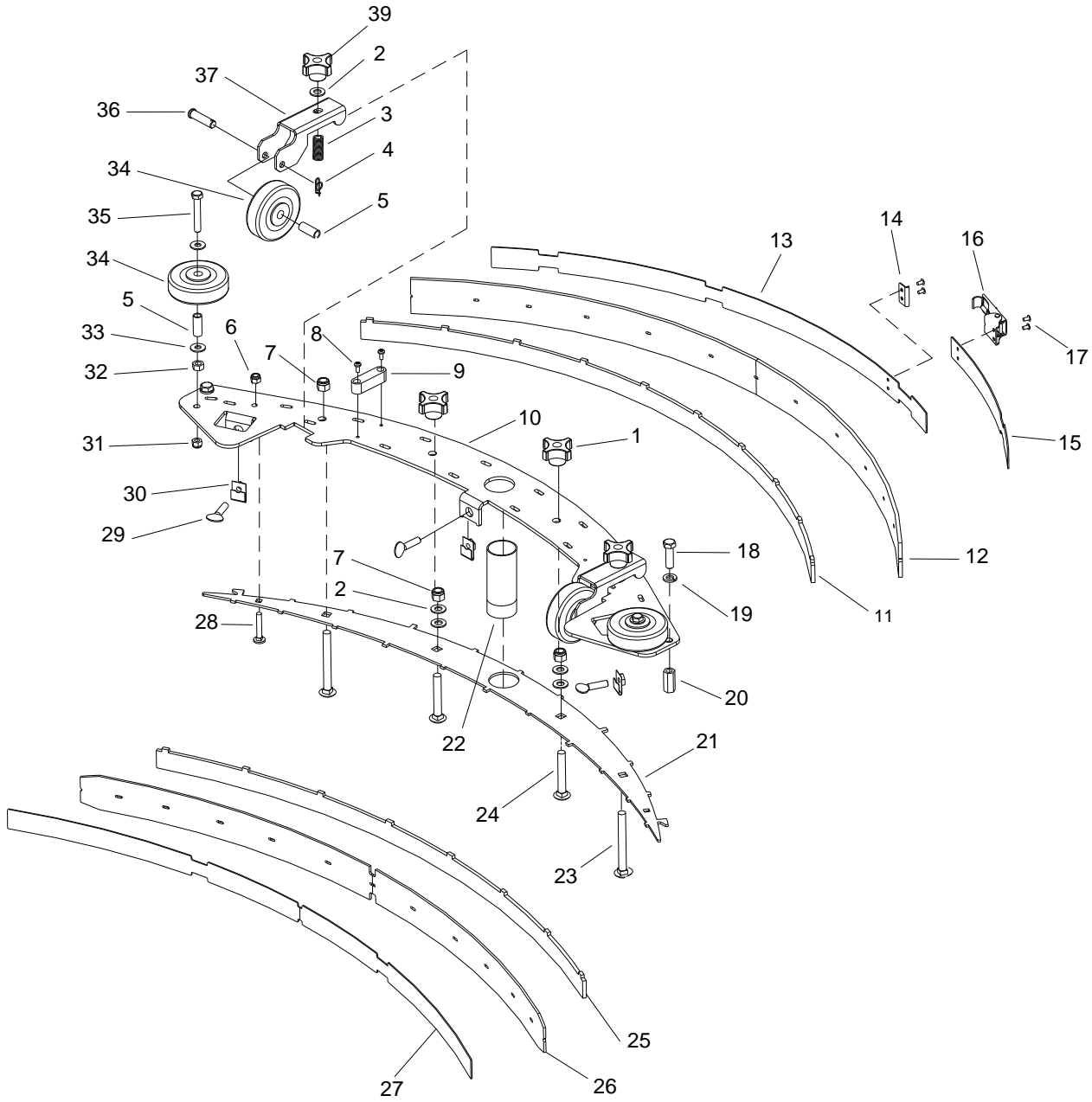

REF	PART NO.	QTY	DESCRIPTION	SERIAL NO. FROM	NOTES
1	86009200	2	KNOB, 3/8-16 4 PRONG ALUM	1000099023	WAS 4
2	86010680	6	WASHER, 3/8 FLT NYL		
3	86007780	2	SPRING COMP .60D X 2.0L X .045W		
4	86008660	2	COTTER 5/16" RING		
5	86001350	4	BUSHING, SPANNER .435 X 1.10		
6	86271870	2	NUT, 1/4-20 HEXTHIN NYLOCK SS		
7	86005630	4	NUT, 3/8-16 HEXTHIN NYLOCK SS		
8	86274130	2	SCREW, 8-32 X .375 PHPNHTC		
9	86009910	1	VIAL, LEVEL		
10	86082460	1	PLATE, SQUEEGEE TOP 40"		
11	86082480	1	PLATE, SQG REAR 40"		
12A	86007490	1	SQUEEGEE, REAR BLADE, LINTEX		
12B	86137040	1	STRIPPER BLADE REAR URETHANE		
13	86066360	1	BAND, SQUEEGEE REAR		
14	86009180	1	STRIKER, SQUEEGEE STRAP REAR		
15	86001330	1	BAND, SQUEEGEE REAR (S)		
16	86009170	1	LATCH, SQUEEGEE STRAP		
17	86006400	4	RIVET, 5/32 X .062-.125GL POP AL		
18	86276920	2	SCREW, 3/8-16 X 1 HHCS SS NP		
19	86010790	2	WASHER, 3/8 X .680 X .094 SPL STL ZNPLT		
20	86005840	2	NUT, 3/8-16 CPL SS		
21	86082490	1	PLATE, SQUEEGEE BOTTOM 40"		
22	86008390	1	TUBE ASM, SQUEEGEE VAC		
23	86276990	2	SCREW, 3/8-16 X 3.5 CARR SS		
24	86276870	2	SCREW, 3/8-16 X 2.5 CARR SS		
25	86082470	1	PLATE, SQG FRONT 40" SPACER		
26A	86009830	1	SQUEEGEE FRONT BLATT LINATEX		
26B	86137050	1	STRIPPER BLADE FRONT URETHANE		
27	86066350	1	BAND, SQUEEGEE FRONT		
28	86277000	2	SCREW, 5/16-18 X 1 THUMB SS		
29	86007040	3	SCREW, 5/16-18 X 1 THUMB SS		
30	86271820	3	NUT, 5/16-18 X .028-.056PR CAGE		
31	86271840	2	NUT 5/16-18 HEX NYLOCK THIN SS		
32	86005650	2	NUT, 5/16-18 HEX STL ZNPLT		
33	86010670	4	WASHER 5/16 FLAT SS		
34	86011020	4	WHEEL 3" DIA CUSHION RUBBER		
35	86276980	2	SCREW, 5/16-18 X 2 HHCS SS		
36	86006270	2	PIN, CLEVIS 5/16 X 1.63 PLTD		
37	86069870	2	BRKT, SQG WHEEL		
38	86026540	-	SQUEEGEE ASM, 32 IN SCRUBHEAD		SERVICE ASM
39	86004890	2	KNOB,ALUM 3/8-16 NYLOCK NUT SS	1000099023	

# Squeegee Lift Linkage (Lower)

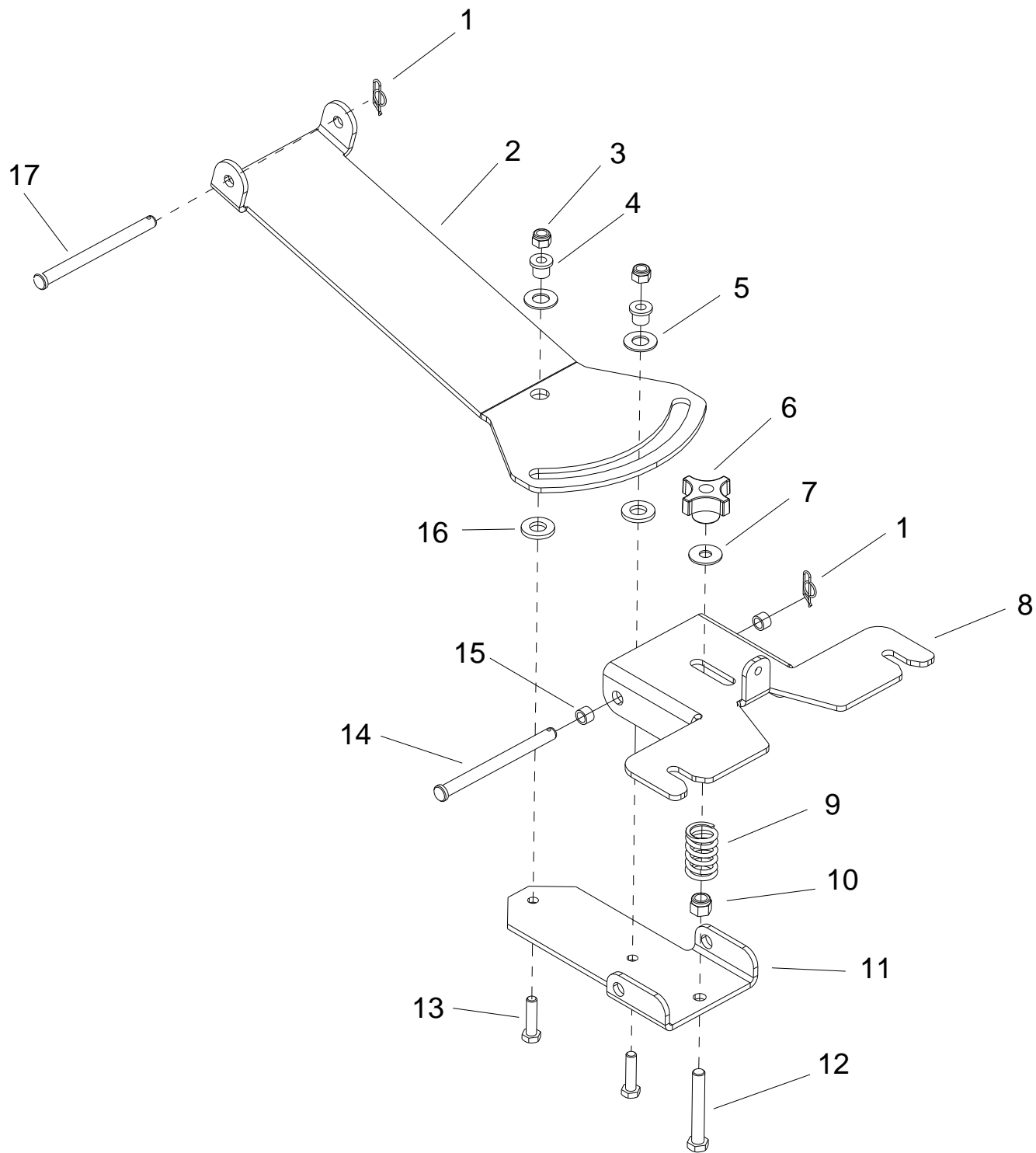

REF	PART NO.	QTY	DESCRIPTION	SERIAL NO. FROM	NOTES
1	86008670	2	COTTER 3/8" RING		
2	86069450	1	BRKT, SQG PIVOT LIFT		
3	86271840	2	NUT 5/16-18 HEX NYLOCK THIN SS		
4	86228840	2	BUSHING, .314 X .502 X .5 FLG		
5	86259410	2	WASHER, .510 X 1 X .063 THR		
6	86009200	1	KNOB, 3/8-16 4 PRONG ALUM		
7	86279510	1	WASHER 3/8 FLAT		
8	86082150	1	PLATE, SQUEEGEE MOUNT		
9	86007270	1	SPRING COMP 1.10OD X 2.0L X .148W		
10	86005630	1	NUT, 3/8-16 HEXTHIN NYLOCK SS		
11	86072530	1	BRKT, CAMBER PIVOT		
12	86276870	1	SCREW, 3/8-16 X 2.5 CARR SS		
13	86277130	2	SCREW, 5/16-18 X 1 CARR SS		
14	86249060	1	PIN, CLEVIS 3/8 X 4.625 STL ZNPLT		
15	86008870	2	BUSHING, 3/8 X .688 FLG		
16	86259400	2	WASHER THRUST.51 ID X 1 ODBRO		
17	86008860	1	PIN, CLEVIS 3/8 X 5.5 STL ZNPLT		

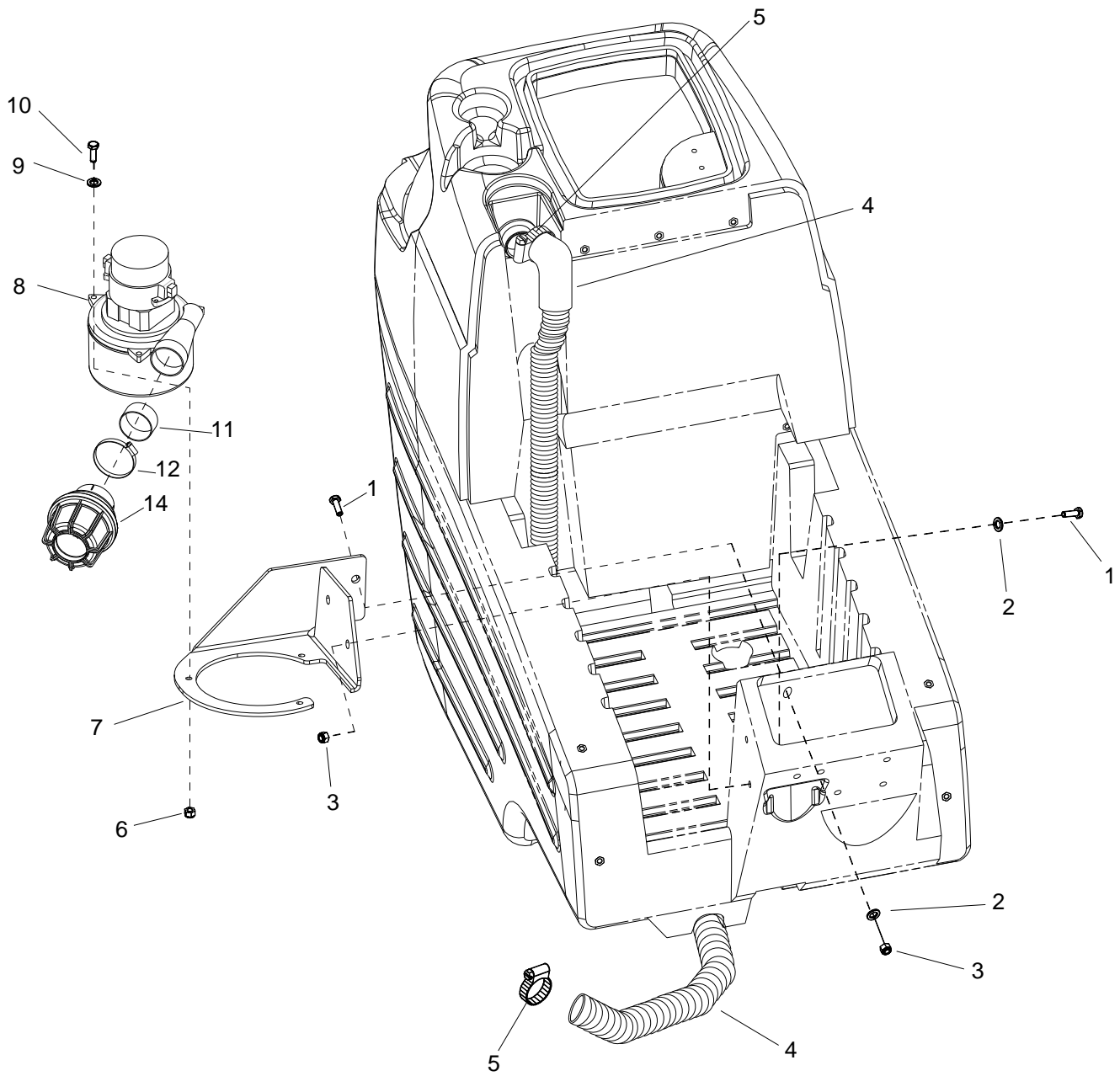



REF	PART NO.	QTY	DESCRIPTION	SERIAL NO. FROM	NOTES
1	86276920	3	SCREW, 3/8-16 X 1 HHCS SS NP		
2	86278910	3	WASHER, 3/8 X .875 X .05 FLT SS		
3	86005630	3	NUT, 3/8-16 HEXTHIN NYLOCK SS		
4	86001620	1	HOSE ASSEMBLY 1.5 BLK VAC X 67		
5	86002400	2	CLAMP, 2.0" WORM GEAR X .312W		
6	86271870	3	NUT, 1/4-20 HEXTHIN NYLOCK SS		
7	86069820	1	BRKT, VACUUM MOUNT, 36V		
8	86005450	1	VAC MOTOR ASM, 36VDC 3 STAGE		
-	86230800	-	BRUSH SET, 36V 3ST VAC AMETEK		SERVICE ONLY
-	86326980	-	BRUSH SET 24/36V VAC WINDSOR	1000122411	SERVICE ONLY
9	86010630	3	WASHER, 1/4 X .625 FLT SS		
10	86273810	3	SCREW, 1/4-20 X 1 HHCS SS		
11	86091170	1	TUBE, 2.0 OD X 1.0L		
12	86233430	1	CLAMP 2.50 WORM GEAR		
13	-	-	-		
14	86064910	1	MUFFLER, VAC MOTOR	1000122451	

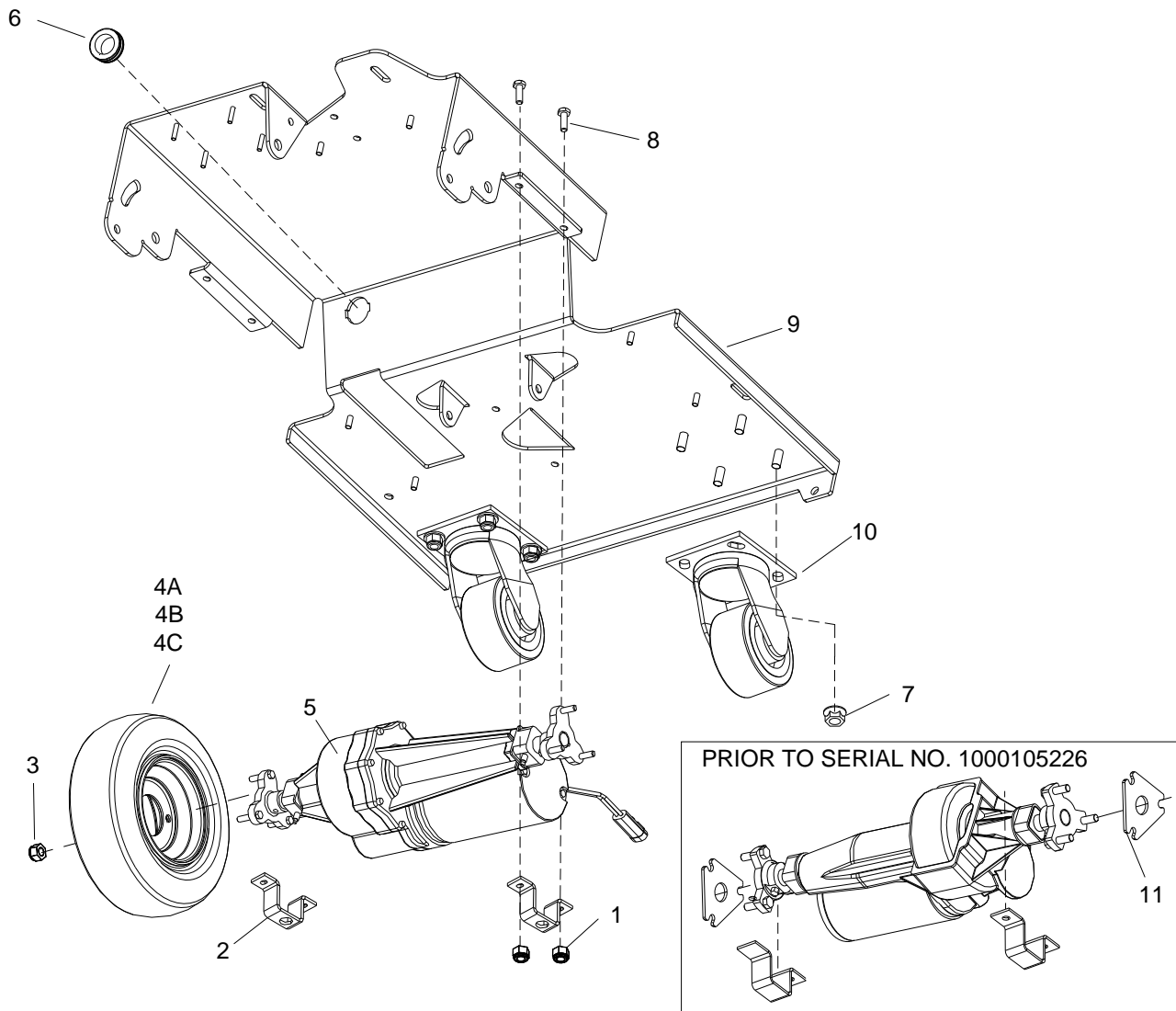

REF	PART NO.	QTY	DESCRIPTION	SERIAL NO. FROM	NOTES
1	86271840	4	NUT 5/16-18 HEX NYLOCK THIN SS		
2	86215770	2	BRKT, TRANSAXLE MOUNT 36V		
3	86010090	6	NUT, 7/16-20 WHL STL ZNPLT		
4A	86090640	2	WHEEL ASM, 12" FMFL N-MARKING		OPTIONAL (STANDARD ON BSCSC326)
4B	86137410	-	WHEEL ASM, 12" SOLID SCBR CMPD		OPTIONAL
4C	86010370	2	WHEEL ASM, 12" FMFL BLK KNOBBY		
5	86000770	1	AXLE, MOTOR DRIVE 36VDC		
-	86001360	-	BRUSH SET, CCL MOTORS		SERVICE ONLY
-	86135870	-	HUB KIT, TRANSAXLE 8.600-077.0		SERVICE ONLY
6	86238430	1	GROMMET 1.00 ID 3/16 GRIP		
7	86270880	8	NUT, 3/8-16 SERFLG STL ZNPLT		
8	86006560	4	SCREW, 5/16-18 X 1 HHCS SS NP		
9	86236660	1	FRAME, MAIN 36 VOLT		
10	86002310	2	CASTER, 4DIA X 2 W X 3.56 R		
11	86087270	2	SPACER, TRANXZXLE 36V	1000105226	SERVICE ONLY

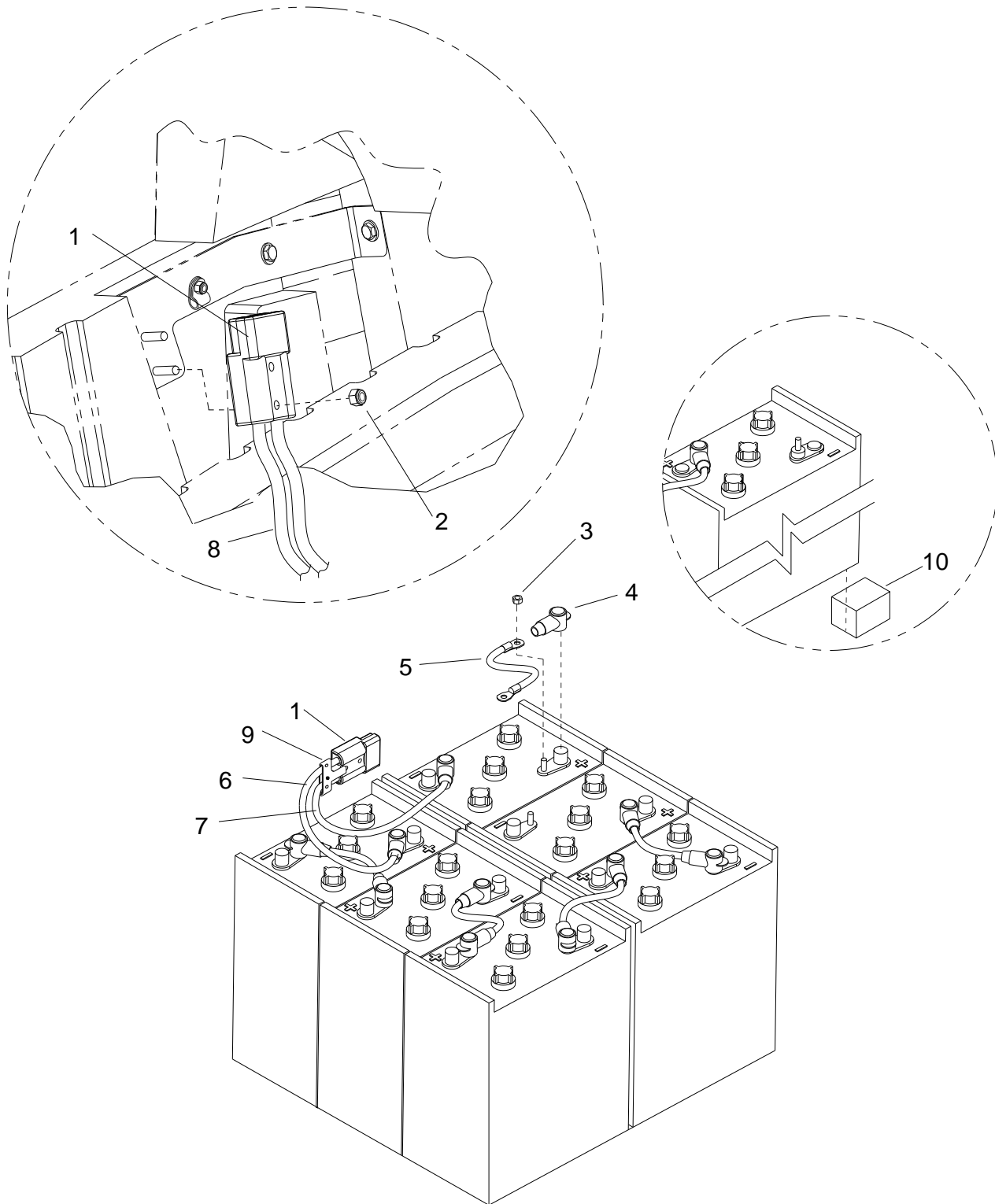

REF	PART NO.	QTY	DESCRIPTION	SERIAL NO. FROM	NOTES
1	86008760	1	CONNECTOR 175 DCA GRY W/O TERMS		
2	86271870	2	NUT, 1/4-20 HEXTHIN NYLOCK SS		
3	86271910	12	NUT, 5/16-18 FLEX LK STL GRA CDPLT		
4	86008920	12	BOOT, RUBBER TERM. ISOLATOR		
5	86009000	5	WIRE, 4 X 9.5 BK 5/16 RING X 5/16 RING		
6	86010850	1	WIRE, 4X20RD CTERM X 5/16RING		
7	86010860	1	WIRE, 4X20 BK CTERM X5/16RING		
8	86260520	2	WIRE, 4X67 BK CTERM X 5/16RING		
9	86233360	1	CLAMP, CABLE KIT		
10	86312710	2	BLOCK, 3.5 X 4 X 5 FOAM		FOR 86312720 BATTERIES



REF	PART NO.	QTY	DESCRIPTION	SERIAL NO. FROM	NOTES
1	86239000	1	HARNESS, PANEL BASIC		
2	86261210	2	DIODE ASM, 76008 X 76008		
3	86003410	1	DIODE ASM, 76075 X 76075		
4	86267340	2	WIRE, 22" RED/18 76040 X 76075		
5	86269300	1	WIRE, 16" RED/18 STRIP X STRIP		
6	86267360	1	WIRE, 14" BLK/18 76011 X 76040		

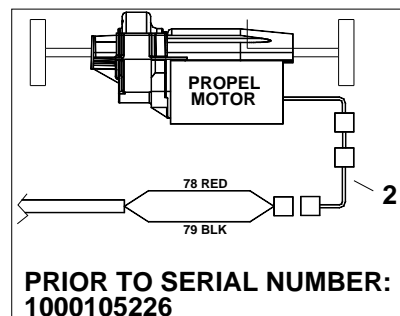
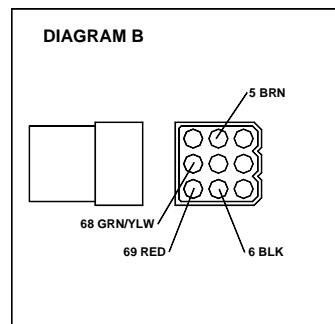
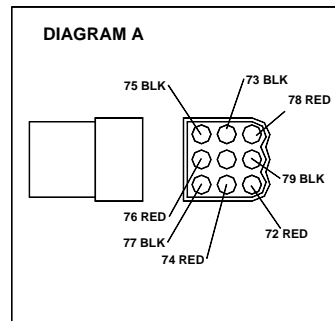
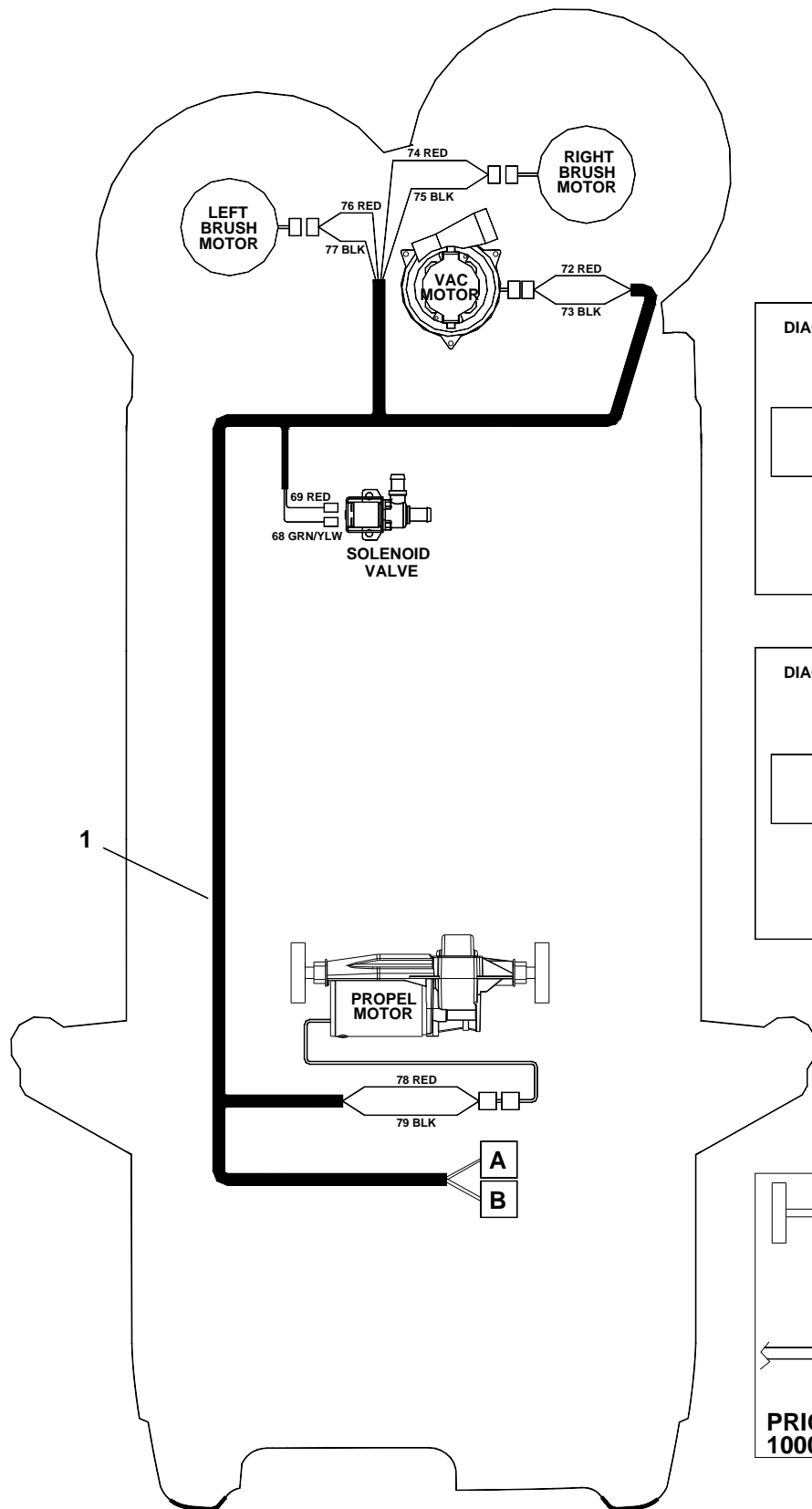



REF	PART NO.	QTY	DESCRIPTION	SERIAL NO. FROM	NOTES
1	86238980	1	HARNESS, MAIN		
2	86260400	1	WIRE ASM, REV POALRITY JUMPER		SERVICE ONLY

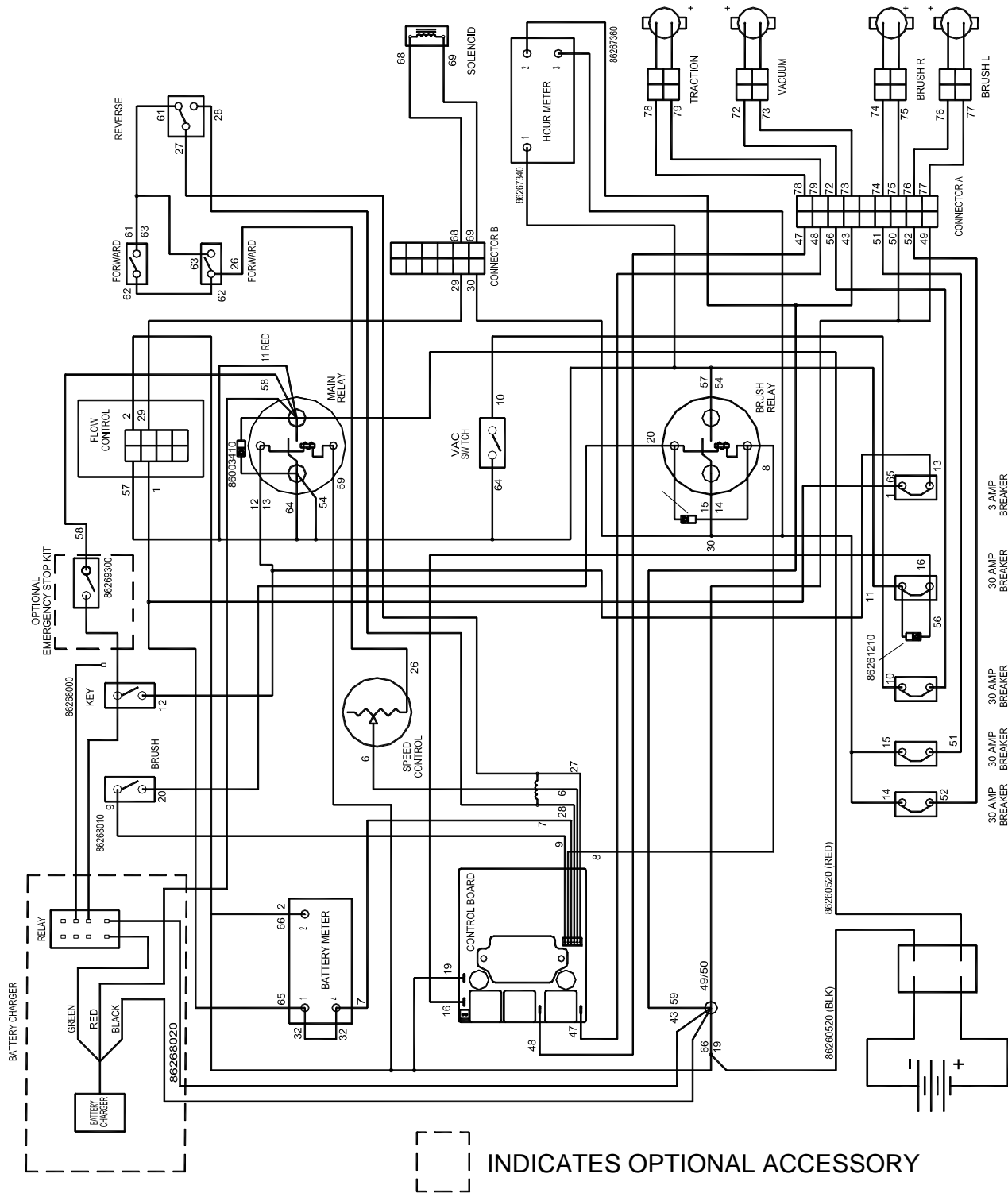

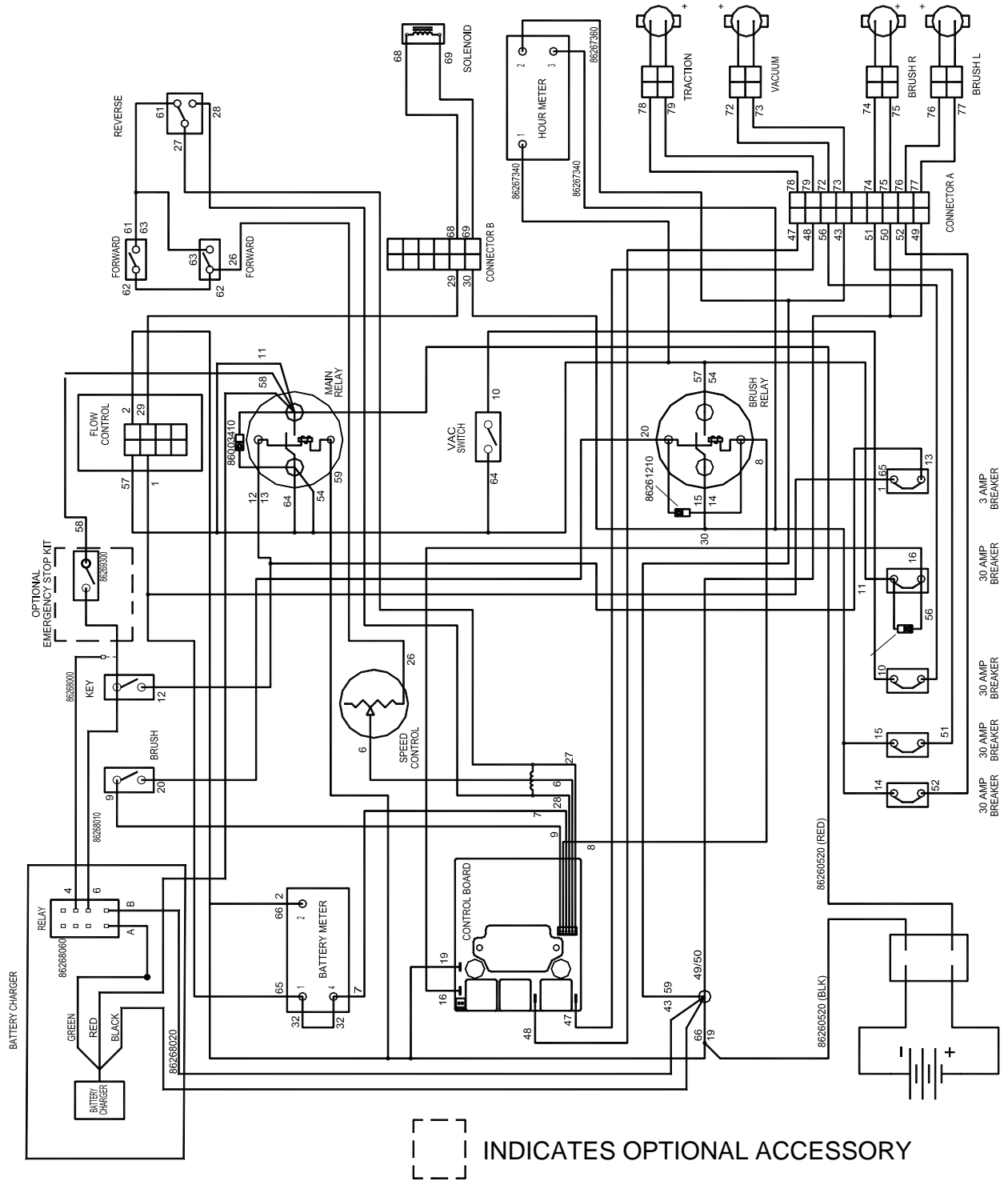

*Notes:*

---

# OPTIONS

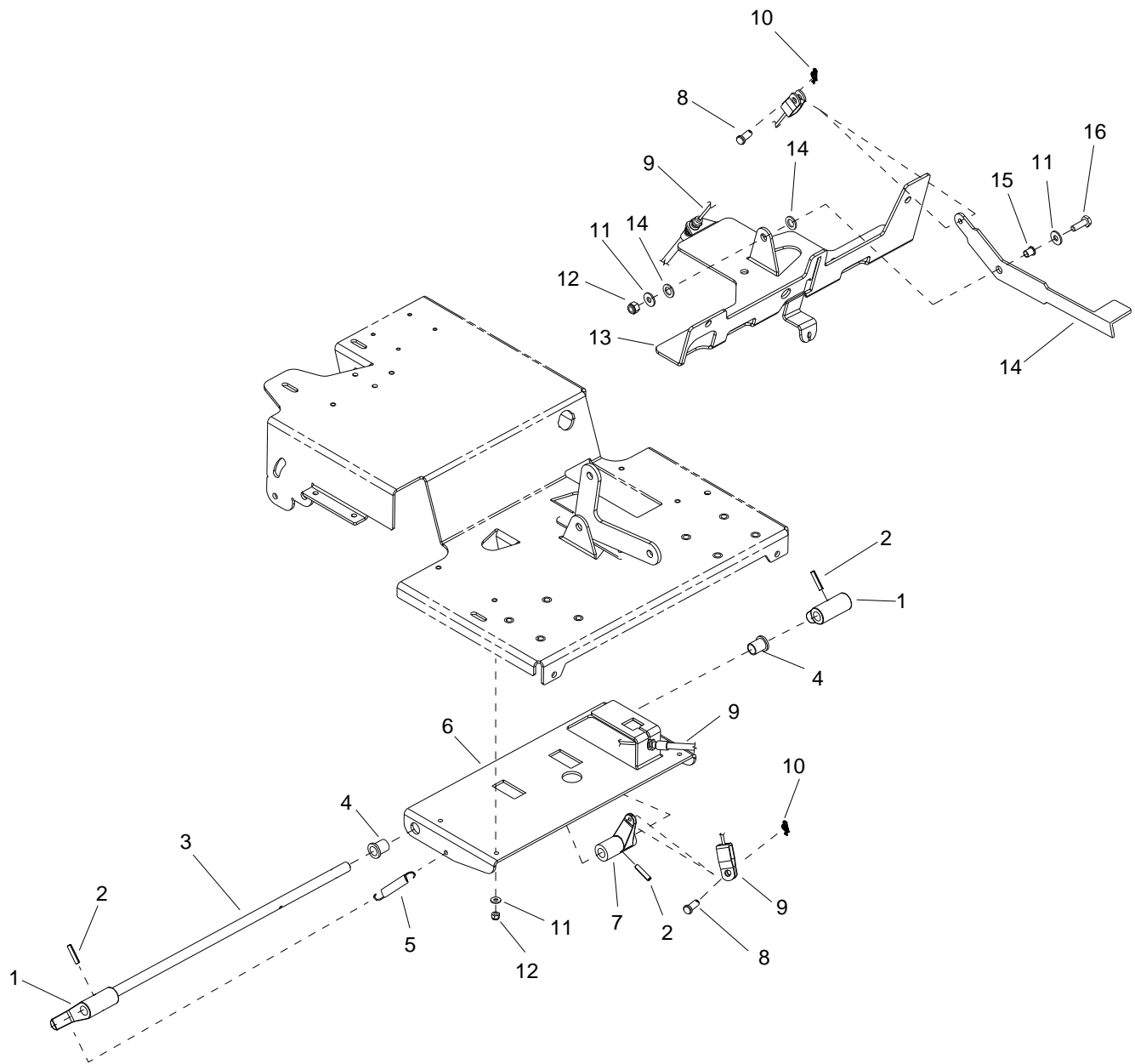

REF	PART NO.	QTY	DESCRIPTION	SERIAL NO. FROM	NOTES
1	86248370	2	PAD, BRAKE		
2	86006220	3	PIN, ROLL 1/4 X 1.25 STL ZNPLT		
3	86251800	1	ROD BRAKE 36V		
4	86231330	2	BUSHING, .6270 X .753 X 1 FLG BRZ		
5	86255060	2	SPRING, EXT .43D X2.50L X.047W		
6	86070070	1	BRKT, LOWER BRAKE MOUNT 24V		
7	86234850	1	CRANK, BRAKE		
8	86272610	2	PIN, CLEVIS 5/16 X .75 STL ZNPLT		
9	86231820	1	CABLE, PARK BRAKE		
10	86008660	2	COTTER, 5/16" RING		
11	86010630	6	WASHER, 1/4 X .625 FLT SS		
12	86271870	5	NUT, 1/4-20 HEXTHIN NYLOCK SS		
13	86070150	1	BRKT, TANK MOUNT 24V		
14	86259400	2	WASHER THRUST.51 ID X 1 ODBRO		
15	86228900	1	BUSHING, .252 X .503 X .75 FLG		
16	86273820	1	SCREW, 1/4-20 X 1.25 HHMS SS		
17	86077280	1	LEVER, BRAKE		

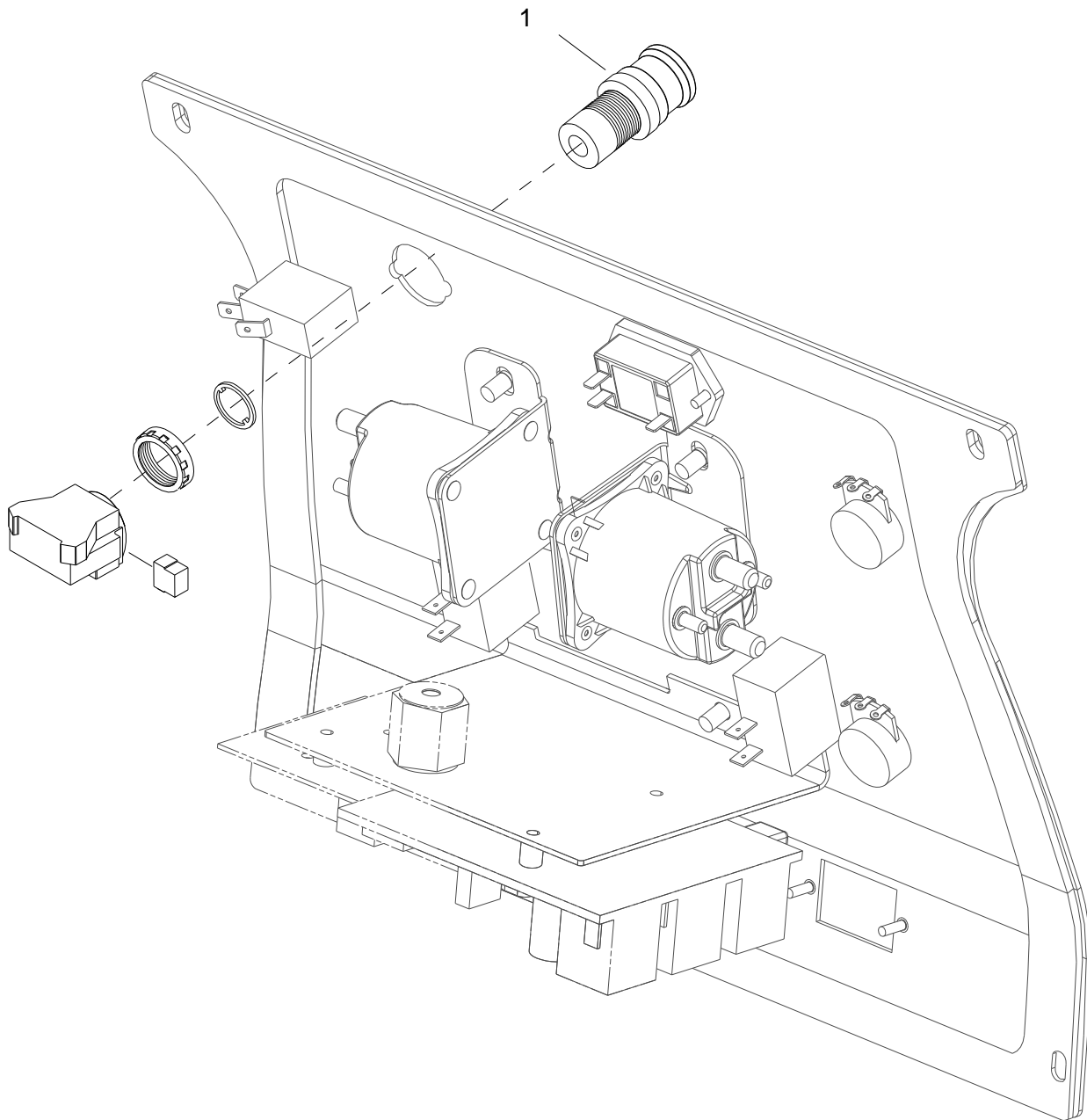



<b>REF</b>	<b>PART NO.</b>	<b>QTY</b>	<b>DESCRIPTION</b>	<b>SERIAL NO. FROM</b>	<b>NOTES</b>
1	86007180	1	SWITCH EMERGENCY STOP		
2	86269300	1	WIRE, 16" RED/18 STRIP X STRIP		NOT SHOWN

# Accessory Pump

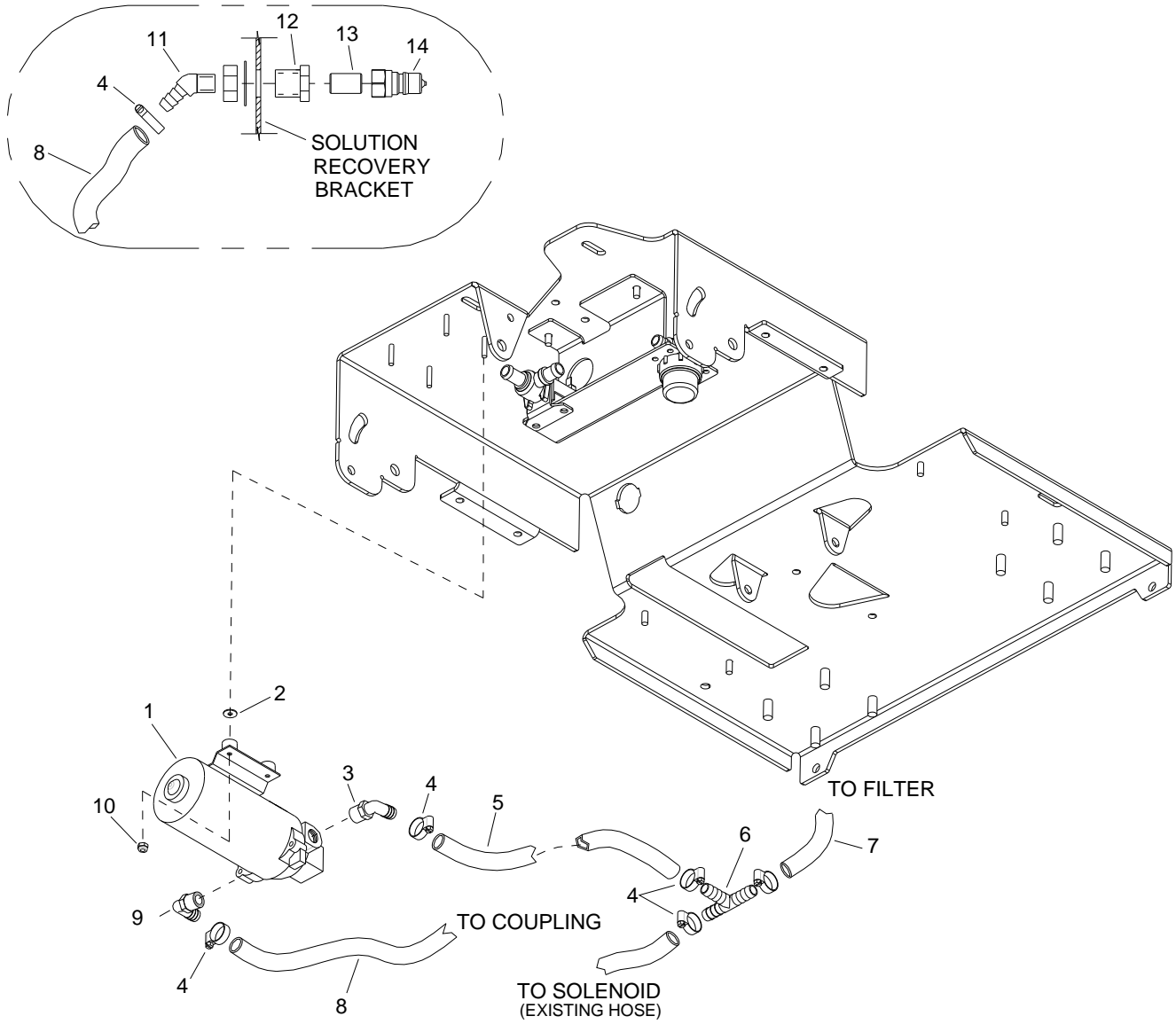

REF	PART NO.	QTY	DESCRIPTION	SERIAL NO. FROM	NOTES
1	86006100	1	PUMP ASM, 36V ACCESSORY		
2	86010650	4	WASHER, 10 X .562 X .032 FLT STL PSVT		
3	86197940	1	HOSEBARB, 3/8MPT X 1/2 90D DL		
4	86233150	6	CLAMP, 3/8 HOSE (D-SLOT)		
5	86280750	1	HOSE, 1/2 WIREBOUND X 21"		
6	86240410	1	HOSEBARB, 1/2 TEE		
7	86282110	1	HOSE, 1/2ID WIRE BOUND X 5.5"		
8	86282200	1	HOSE 3/8ID WIRE BOUND X 40"		
9	86001550	1	HOSEBARB, 3/8MPT X 3/8 90D		
10	86270990	4	NUT, 10-32 HEX NYLOCK SS		
11	86197620	1	HOSEBARB, 1/4MPT X 3/8 45D DL		
12	86002470	1	COUPLING, 1/4 ANCHOR W/1" HEX		
13	86005590	1	NIPPLE, 1/4 CLOSE		
14	86005580	1	NIPPLE 1/4 FPT QD		
-	86239020	1	HARNESS PUMP KIT ADAPTER		NOT SHOWN
-	86264940	1	CABLE TIE 11.38" UL/CSA		NOT SHOWN

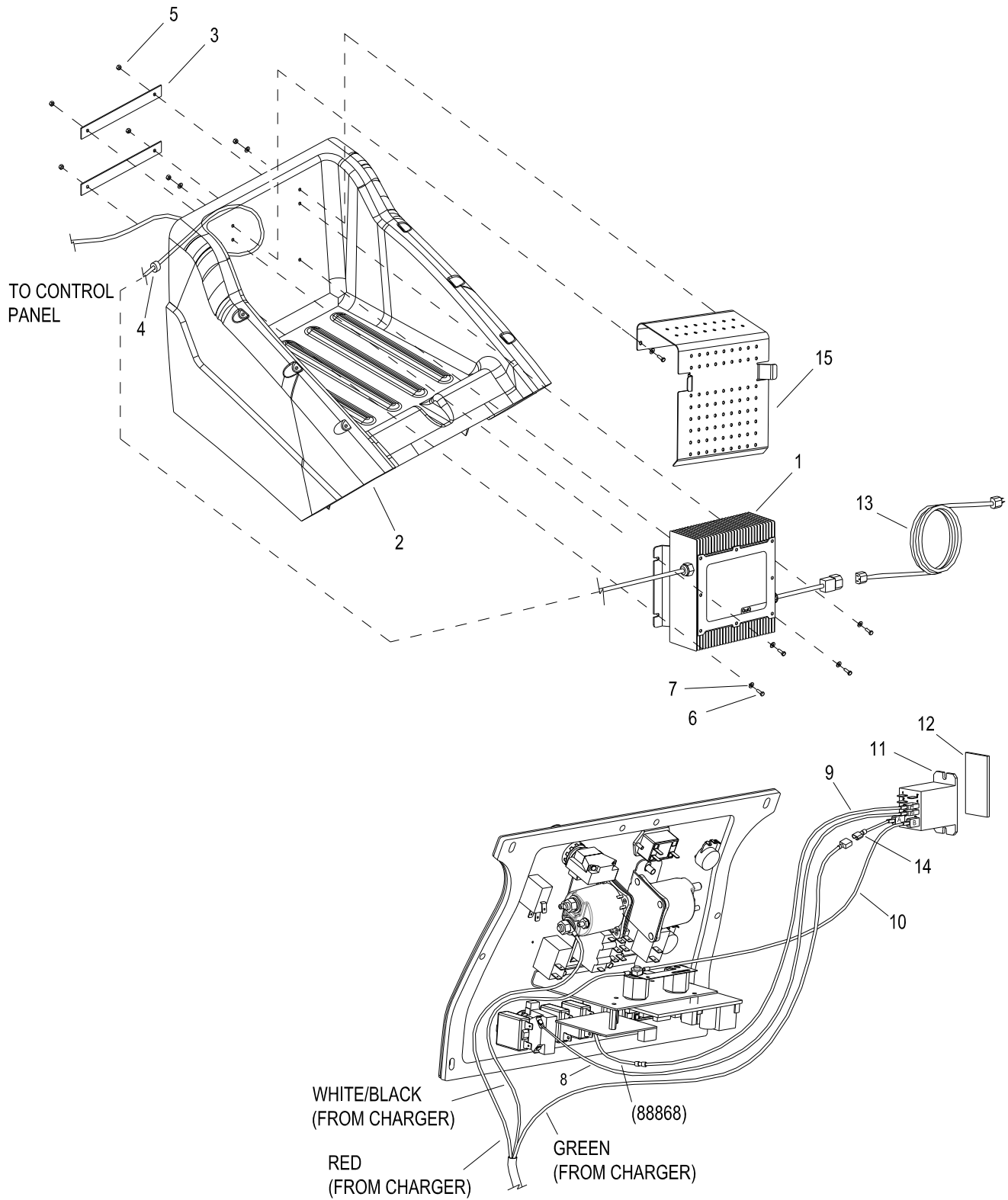

REF	PART NO.	QTY	DESCRIPTION	SERIAL NO. FROM	NOTES
1	86232950	1	CHARGER, DELTA-Q, 36V, 21A		
2	86031800	1	COVER, TOP, 36V GRY OBC		
3	86073430	2	BRKT, CHARGER DELTA-Q		
4	86226550	1	GROMMET, 1/2 ID X 1/4 GROOVE		
5	86005810	6	NUT, 1/4-20 HEX NYLOCK SS		
6	86275490	6	SCREW, 1/4-20 X 1 SCHBTNHCS BLKOX		
7	86279520	8	WASHER, 1/4 X .625 X .065 FLT BLK ZNPLT		
8	86268010	1	WIRE, 20" RED/16 76033 X STRIP		
9	86268000	1	WIRE, 12" RED/16 76033 X 76009		
10	86268020	1	WIRE, 20" BLK/16 76001 X 76033		
11	86251410	1	RELAY 15A 36V MINI		
12	86133400	0.125	TAPE, 1/32T X 1.0 2SA		
13	86234390	1	SP CORD ASM, 16/3 SJTW X 2M IEC		
14	86268060	1	WIRE, 2" GRN/16 76033 X 76044		
15	86075390	1	COVER, CHARGER DELTA-Q		

*Suggested Spare Parts*

<b>PART NO.</b>	<b>DESCRIPTION</b>	<b>SERIAL NO.FROM</b>	<b>NOTES</b>
86001910	BREAKER, 30A 50VDC CIRCUIT		
86002000	BREAKER, 3 AMP 1681-090-300		
86006370	RELAY 36VDC 100AMP HVY DUTY		
86007140	SWITCH SPST 2-POSITION ROCKER		
86009200	KNOB, 3/8-16 4 PRONG ALUM		
86007490	SQUEEGEE, REAR BLADE, LINTEX		
86009830	SQUEEGEE FRONT BLATT LINATEX		
86003990	GASKET, DOME		
86236410	FLOAT VAC SHUT OFF		
86001430	BLADE AQ LEFT 16 INCH		
86001420	BLADE AQ RIGHT 16 INCH		
86004860	KEY, SWITCH		
86007530	SKIRT 32 INCH LEFT		
86007540	SKIRT 32 INCH RIGHT		
86230800	BRUSH SET, 36V 3ST VAC AMETEK		
86326980	BRUSH SET 24/36V VAC WINDSOR		

