

Spare parts list
(5.971-060.0) Spare parts list Pivot

Table of contents

Spare parts list Pivot (5.971-060.0)	3
10 Retaining bracket and switch (0.201-344.0)	4
11 Retaining bracket (0.201-345.0).....	5
12 Switch (0.201-346.0).....	8
20 Top part (0.201-347.0)	10
30 Bottom part individual parts (0.201-356.0)	13
31 Brush housing (0.201-357.0).....	14
32 Transmission (0.201-303.0)	16
40 Accessories pad roll (0.162-883.0)	19

Spare parts list Pivot (5.971-060.0)

Pos	Material #	Name
10	0.201-344.0	Retaining bracket and switch
20	0.201-347.0	Top part
30	0.201-356.0	Bottom part individual parts
40	0.162-883.0	Accessories pad roll

10 Retaining bracket and switch (0.201-344.0)

Pos	Material #	Name	Qty.	Unit
11	0.201-345.0	Retaining bracket	1.000	ST
12	0.201-346.0	Switch	1.000	ST

11 Retaining bracket (0.201-345.0)

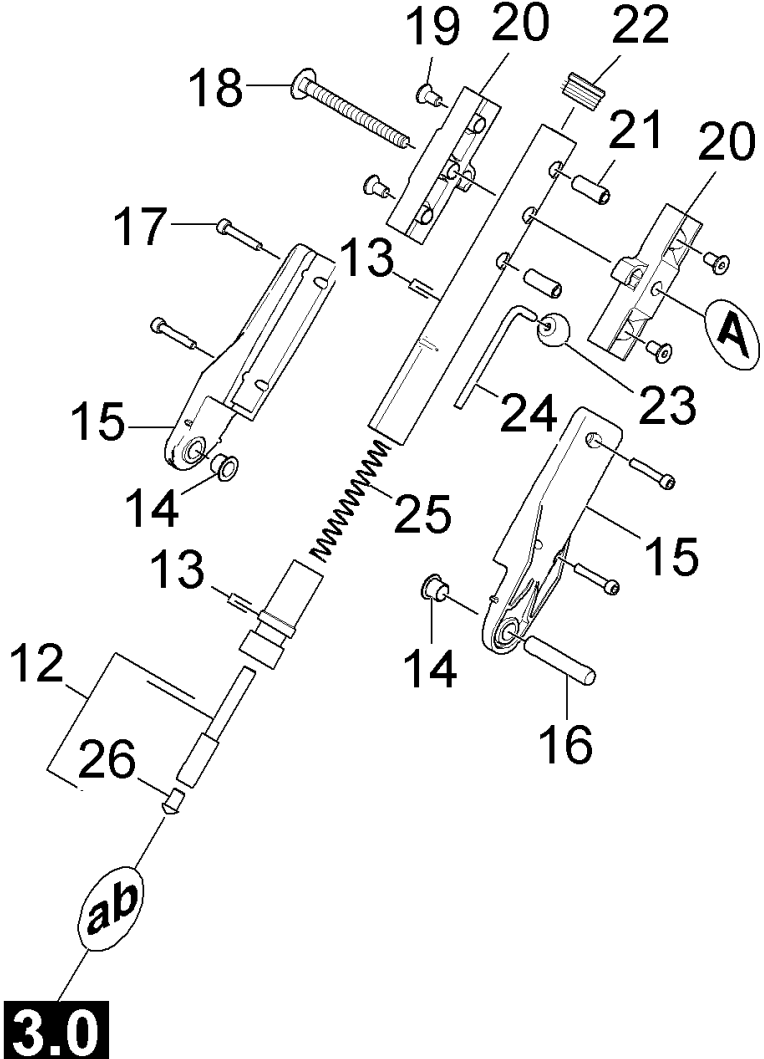
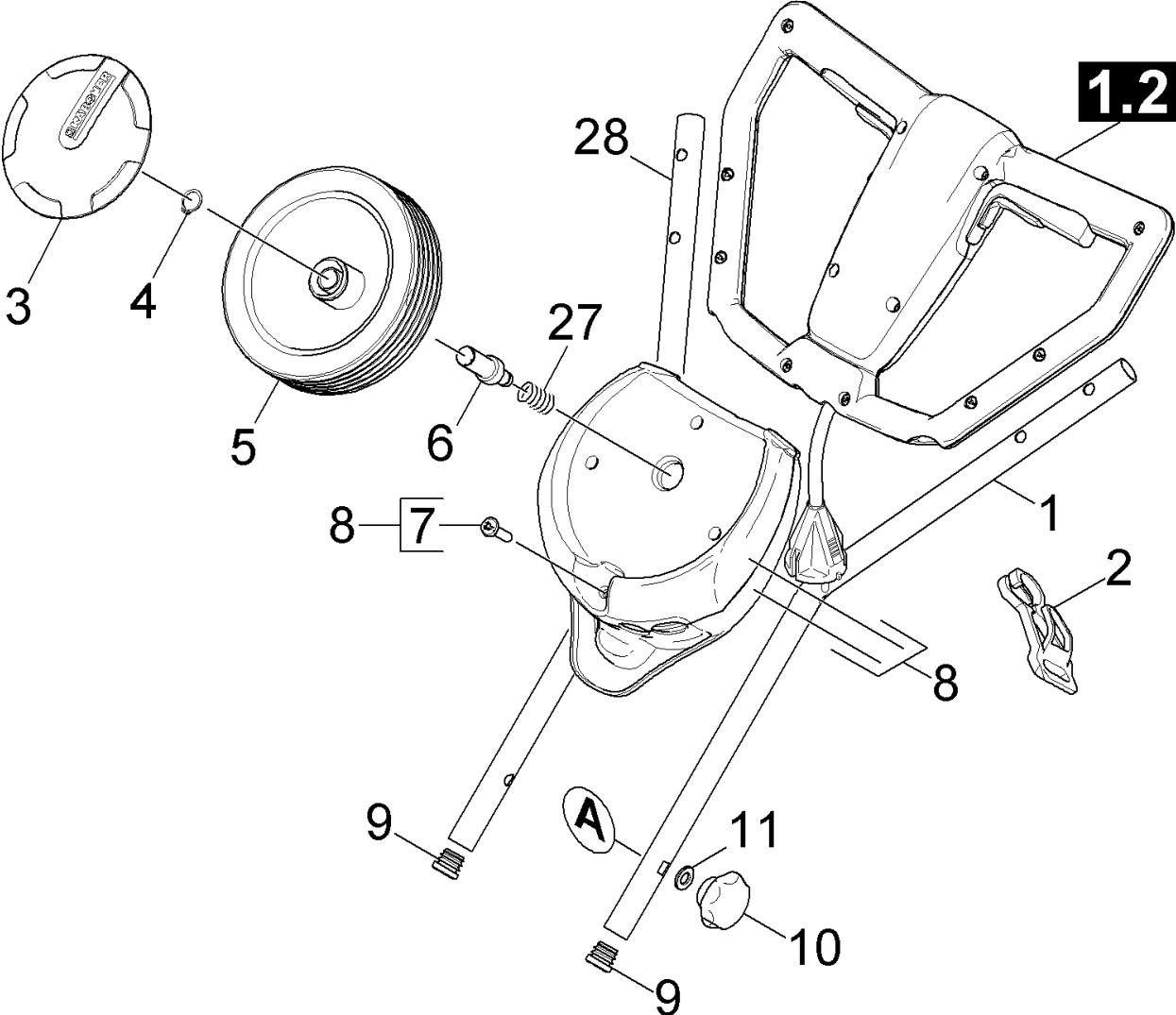

11 Retaining bracket (0.201-345.0)

ET/VT (spare/wear parts)	Pos	Material #	Name	Qty.	Unit
	1	5.034-819.0	Retaining bracket top part	2.000	ST
	2	6.641-776.0	Strain relief	1.000	ST
	3	6.435-349.0	Wheel cab black neutrally	2.000	ST
X-X	4	7.343-005.0	Locking ring 16x1-FST-PHR DIN 471	2.000	ST
X-X	5	6.435-196.0	Wheel D 180	2.000	ST
	6	5.034-795.0	Axle feed wheel	2.000	ST
X-X	7	7.303-108.0	Screw 5x20 -10.9-R2R (In6Rd)	1.000	ST
	8	4.783-003.0	Set wheel vat	1.000	ST
	9	6.368-419.0	Drain plug pipe Ø 18-20mm	2.000	ST
	10	6.321-028.0	Star grip K 50	1.000	ST
X-X	11	7.312-005.0	Washer 10-200HV-A3E ISO 7090	1.000	ST
X	12	4.034-162.0	Spring catch bolt cap	1.000	ST
	13	4.034-161.0	Retaining bracket bottom part complete B	1.000	ST
X-X	14	6.347-084.0	Flanged bushing	2.000	ST
	15	5.031-506.0	Moulded part push handle	2.000	ST
	16	5.316-852.0	Bolt joint push handle	1.000	ST
	17	7.306-025.0	Cylinder head screw M 6x35-8.8-A2E ISO4	4.000	ST
	18	7.303-201.0	Saucer-head screw M10x110-ST-A0P DIN 60	1.000	ST
X-X	19	7.305-637.0	Countersunk screw M8x16-A2-70 ISO 10642	4.000	ST
	20	5.034-822.0	Clamping part shearing shackle	2.000	ST
	21	5.110-825.0	Sleeve with female thread	2.000	ST
	22	6.385-783.0	Plug	1.000	ST
	23	7.321-030.0	Spherical head C 25-KU.sw DIN 319	1.000	ST
	24	5.034-821.0	Bar push handle lock-in position	1.000	ST
X-X	25	5.332-320.0	Helical spring	1.000	ST

11 Retaining bracket (0.201-345.0)

ET/VT (spare/wear parts)	Pos	Material #	Name	Qty.	Unit
	26	5.368-002.0	Cap bolt	1.000	ST
	27	5.332-981.0	Pressure spring	2.000	ST
	28	4.034-207.0	Retaining bracket top part replacement B	1.000	ST

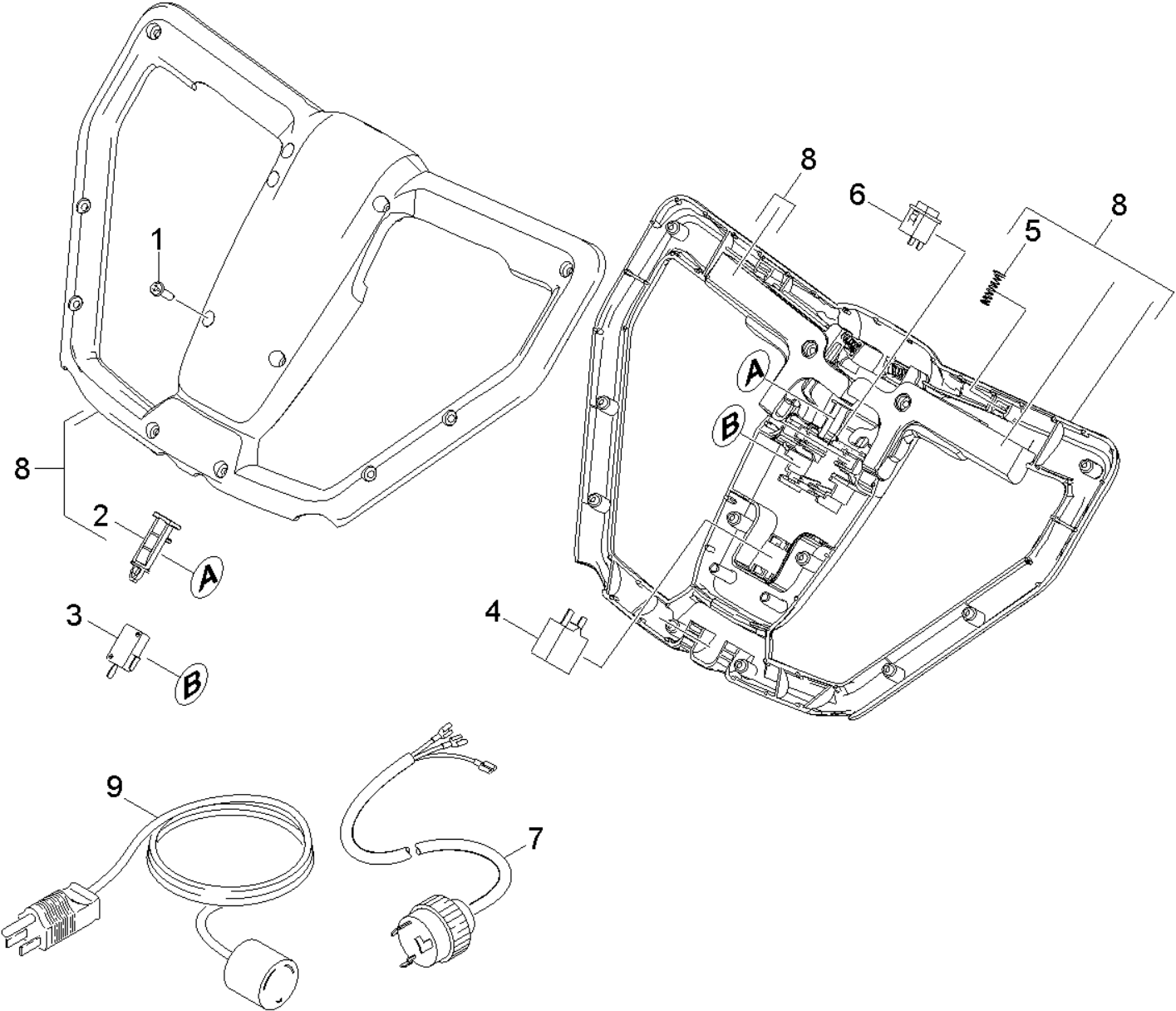

12 Switch (0.201-346.0)

ET/VT (spare/wear parts)	Pos	Material #	Name	Qty.	Unit
X-X	1	7.303-108.0	Screw 5x20 -10.9-R2R (In6Rd)	12.000	ST
	2	5.050-433.0	Slide of a press switch	1.000	ST
X-X	3	6.630-426.0	Main switch	2.000	ST
	4	6.630-428.0	Motor protecting switch 9A	1.000	ST
	5	5.332-944.0	Spring conical	5.000	ST
X	6	6.630-427.0	Switch water pump	2.000	ST
	7	6.649-696.0	Power cable SaberBlade 16	1.000	ST
	8	4.783-007.0	Set operating unit replacement	1.000	ST
	9	8.623-411.0	CORD SET,14/3 SJTW-A X 50' YLW	1.000	ST

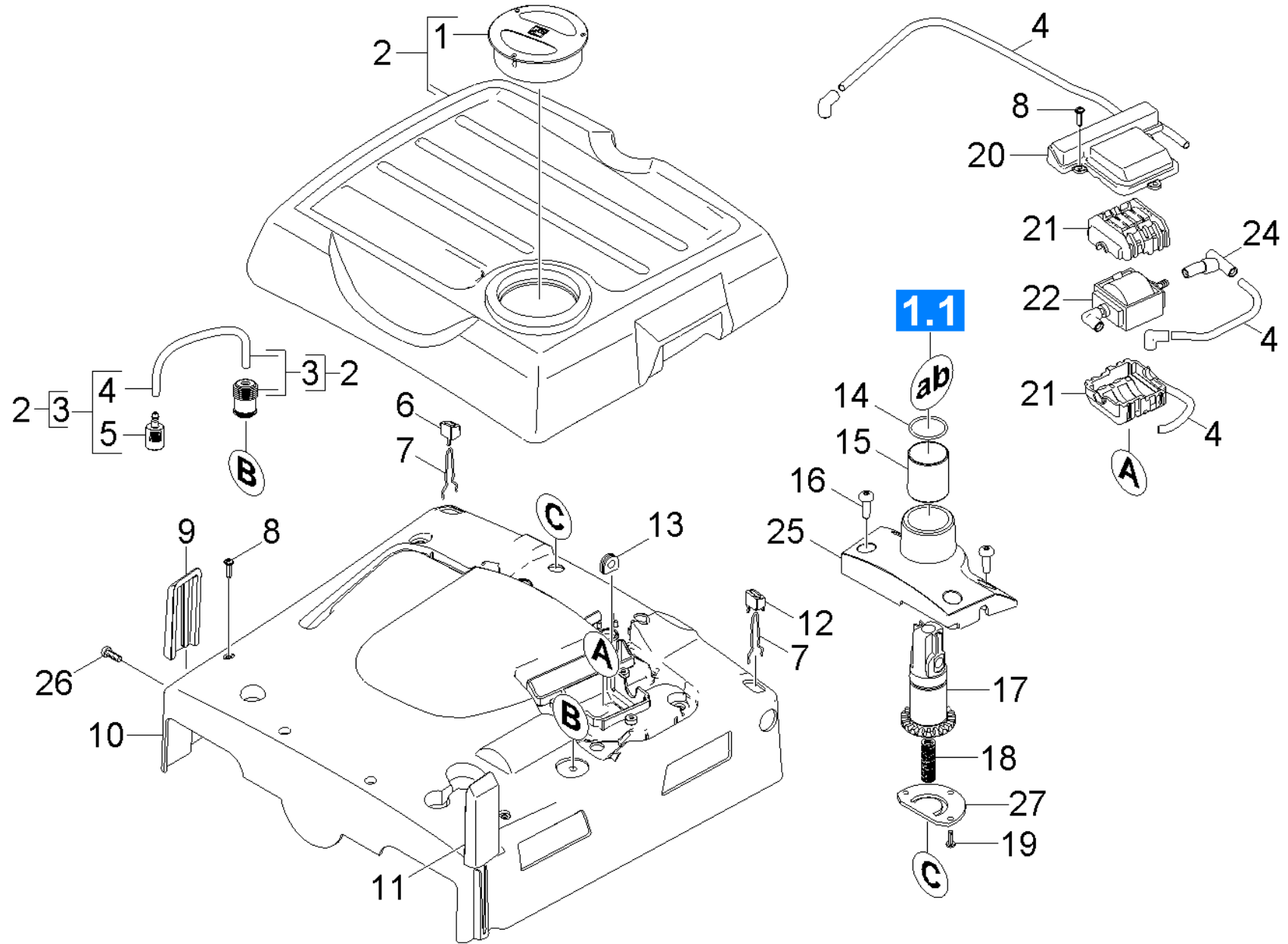

20 Top part (0.201-347.0)

ET/VT (spare/wear parts)	Pos	Material #	Name	Qty.	Unit	Footnote text
X	1	5.063-650.0	Cover	1.000	ST	
	2	4.783-010.0	Tank replacement Pivot	1.000	ST	
	3	4.034-159.0	Valve tank BRS	1.000	ST	
	4	6.388-216.0	Hose DN 5	4.000	M	TO ORDER AS CUT GOODS
X	5	5.731-652.0	Filter with weight	1.000	ST	
	6	5.050-728.0	Pusher rear grey	1.000	ST	
	7	5.034-839.0	Spring feed wheel	2.000	ST	
X-X	8	7.303-108.0	Screw 5x20 -10.9-R2R (In6Rd)	9.000	ST	
	9	5.050-516.0	Ram protection right	1.000	ST	
	10	5.050-909.0	Cover brush housing Pivot	1.000	ST	
	11	5.050-517.0	Ram protection left	1.000	ST	
	12	5.050-726.0	Pusher front feed wheel grau	1.000	ST	
	13	6.648-064.0	Cable bushing	2.000	ST	
	14	6.362-605.0	O-Ring seal 36,17x 2,62	1.000	ST	
	15	6.403-042.0	Plain bearing 40/44x50	1.000	ST	
X-X	16	7.303-069.0	Screw M 8x25-ST-R3R (IN6RD)	4.000	ST	
	17	5.033-479.0	Moulded part beam joint	1.000	ST	
	18	6.330-140.0	Pressure spring	1.000	ST	
X-X	19	7.306-193.0	Screw M6x16 -A2-70 (In6Rd)	3.000	ST	
	20	5.050-410.0	Cover pump	1.000	ST	
	21	5.050-408.0	Bearing pump	1.000	ST	
X-X	22	6.473-532.0	Motor pump 120V 60Hz	1.000	ST	
X	24	4.050-956.0	Check valve	1.000	ST	
X	25	5.050-527.0	Flange drawbar worked	1.000	ST	
	26	6.303-057.0	Countersunk screw 5,0X 16-ST-A2R	2.000	ST	

20 Top part (0.201-347.0)

ET/VT (spare/wear parts)	Pos	Material #	Name	Qty.	Unit	Footnote text
X-X	27	4.060-835.0	Plate stop swivel joint	1.000	ST	

30 Bottom part individual parts (0.201-356.0)

Pos	Material #	Name	Qty.	Unit
31	0.201-357.0	Brush housing	1.000	ST
32	0.201-303.0	Transmission	1.000	ST

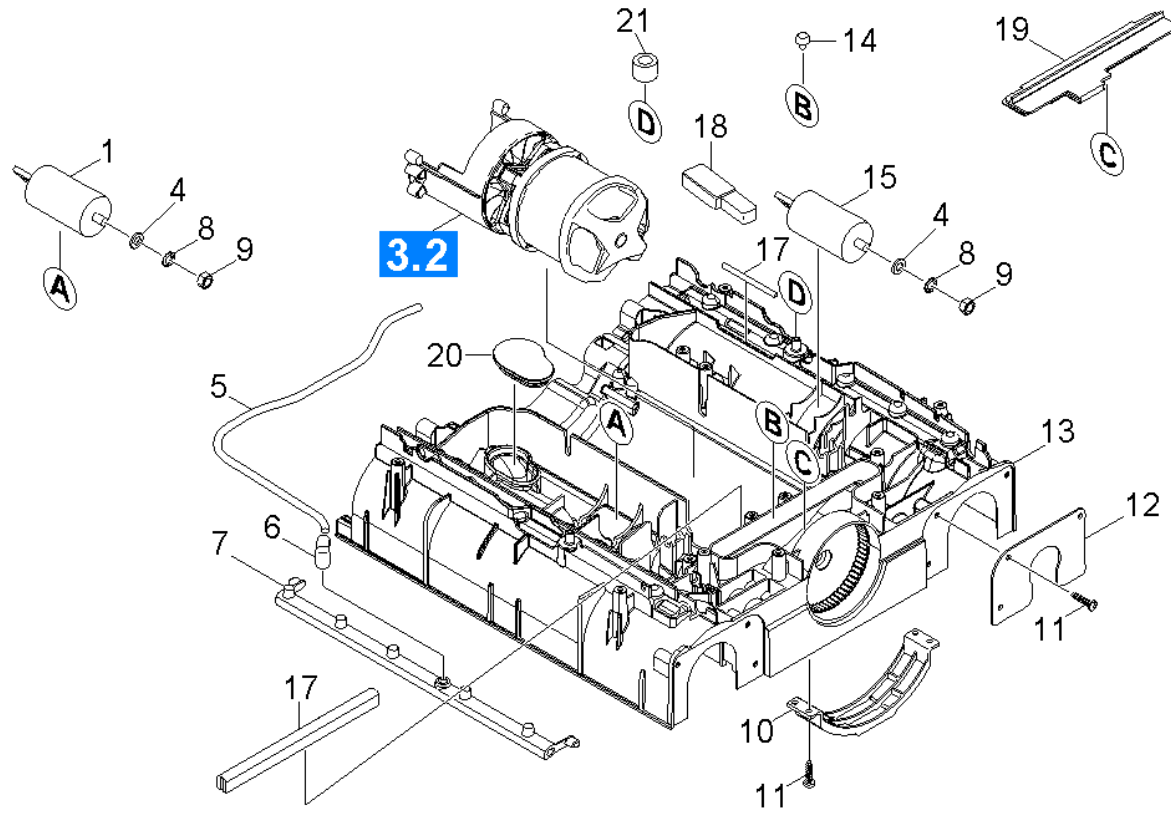

31 Brush housing (0.201-357.0)

ET/VT (spare/wear parts)	Pos	Material #	Name	Qty.	Unit	Footnote text
	1	6.661-220.0	Capacitor	1.000	ST	
X-X	4	7.312-004.0	Washer 8 -200HV-A3E ISO 7090	2.000	ST	
	5	6.388-216.0	Hose DN 5	1.000	M	TO ORDER AS CUT GOODS
	6	5.050-411.0	Angle bushing water distributor	2.000	ST	
	7	5.050-409.0	Water distributor	2.000	ST	
	8	7.312-233.0	Serrated lock washer A8,4-FSt-A3E DIN67	2.000	ST	
X-X	9	7.311-004.0	Hexagon nut M8 -8-A3E ISO 4032	2.000	ST	
X	10	5.050-592.0	Edge protection	2.000	ST	
X-X	11	7.303-212.0	Screw 5x20 -A2-70 (In6Rd)	14.000	ST	
	12	5.034-799.0	Plate brush holder	2.000	ST	
	13	5.050-307.0	Brush housing	1.000	ST	
	14	6.339-249.0	Rubber buffer motor	2.000	ST	
X	15	6.661-221.0	Capacitor	1.000	ST	
X-X	17	6.273-055.0	Profile gasket	2.000	M	TO ORDER AS CUT GOODS
X	18	6.682-975.0	Starting electronic MAS (d) 100-120V	1.000	ST	
	19	5.050-421.0	Sealing carriage	1.000	ST	
	20	5.050-422.0	Sealing air circulation	1.000	ST	
X-X	21	5.034-894.0	Joint ring	2.000	ST	

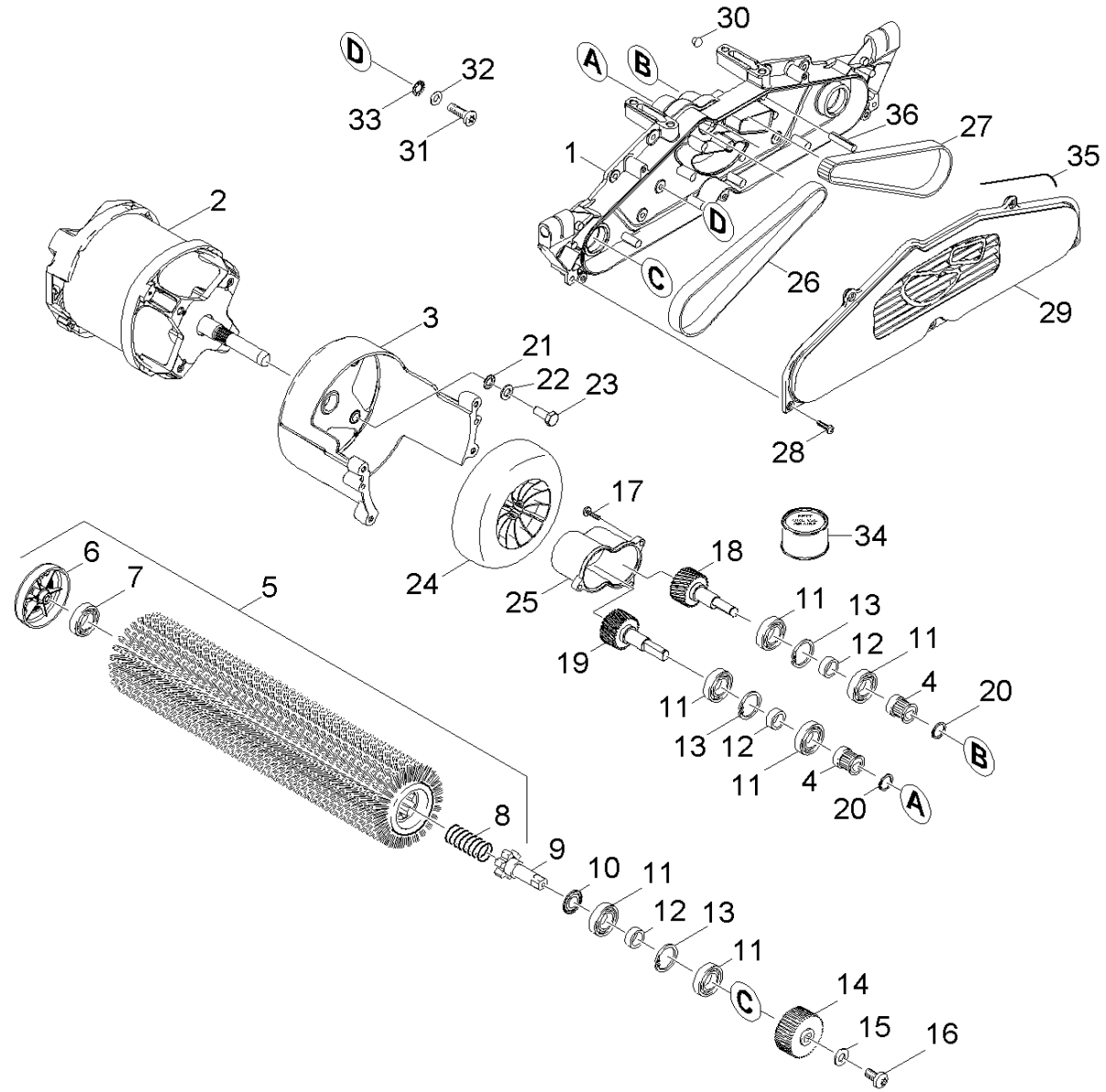

32 Transmission (0.201-303.0)

ET/VT (spare/wear parts)	Pos	Material #	Name	Qty.	Unit	var. information	Footnote text
	1	5.050-445.0	Gear case worked	1.000	ST		
	2	6.680-046.0	Electric motor 1,1 kW 120 V	1.000	ST		
	3	5.050-432.0	Flange motor worked	1.000	ST		
X-X	4	5.625-318.0	Belt pulley 21Z	2.000	ST		
X-X	5	4.762-251.0	Roller brush orange (old colour red)	2.000	ST		
X-X	5	4.762-481.0	Roller brush black complete	2.000	ST		
X-X	5	4.762-250.0	Roller brush white (old colour black)	2.000	ST		
X-X	5	4.762-252.0	Roller brush green (old colour grey)	2.000	ST		
X-X	5	4.762-274.0	Roller brush horsehair nature BR VS 400	2.000	ST		
X-X	5	4.762-458.0	Roller brush red complete	2.000	ST		
X-X	6	4.038-677.0	Sheet metal component thread deflector	2.000	ST		
X-X	7	6.401-363.0	Ball bearing	2.000	ST		
X-X	8	5.332-114.0	Helical spring	2.000	ST		
	9	5.100-571.0	Driveshaft 59mm	2.000	ST		
X-X	10	6.363-292.0	Joint ring NILOS 6002	2.000	ST		
X-X	11	7.401-115.0	Ball bearing 6002-2RS -WÄELZLAGST DIN 62	8.000	ST		
X-X	12	5.110-686.0	Spacer sleeve	4.000	ST		
X-X	13	7.343-231.0	Locking ring 32x1,2 -St-ph DIN 472	4.000	ST		
X-X	14	5.625-357.0	Belt pulley 56Z HTD 3M	2.000	ST		
X-X	15	7.312-292.0	Washer 6 -A2 ISO 7093-1	2.000	ST		
X-X	16	7.306-192.0	Screw M 6x 12-A2-70 (In6Rd)	2.000	ST		
	17	7.303-039.0	Screw M5x16 -St-A2R (In6Rd)	3.000	ST		
X-X	18	4.100-125.0	Shaft gear left BR VS	1.000	ST		
X-X	19	4.100-234.0	Shaft gear right	1.000	ST		
X-X	20	7.343-003.0	Locking ring 12x1-Rf-St DIN 471	2.000	ST		

32 Transmission (0.201-303.0)

ET/VT (spare/wear parts)	Pos	Material #	Name	Qty.	Unit	var. information	Footnote text
	21	7.312-233.0	Serrated lock washer A8,4-FSt-A3E DIN67	4.000	ST		
X-X	22	7.312-017.0	Washer 8-A2 ISO 7089	4.000	ST		
X-X	23	7.304-397.0	Hexagonal head screw M8x20-8.8-A2E ISO	4.000	ST		
X	24	5.050-358.0	Blower wheel	1.000	ST		
	25	5.050-357.0	Cover gear	1.000	ST		
X-X	26	6.348-444.0	Toothed belt HTD-420-3M-15 CXPIII	1.000	ST		
X-X	27	6.348-431.0	Toothed belt HTD-474-3M-15 CXPIII	1.000	ST		
X-X	28	7.303-108.0	Screw 5x20 -10.9-R2R (In6Rd)	6.000	ST		
	29	5.050-310.0	Cover gear case	1.000	ST		
	30	6.368-347.0	Cap D5	1.000	ST		
X-X	31	7.306-105.0	Screw M6x30 -8.8-R3R (In6Rd)	4.000	ST		
X-X	32	7.312-003.0	Washer 6 -200HV-A3E ISO 7090	1.000	ST		
	33	7.312-232.0	Serrated lock washer A6,4-FSt-A3E DIN 6	4.000	ST		
	34	6.288-095.0	Viscous oil	1.000	ST	50g	
	35	6.273-037.0	Seal string cellular rubber 3	1.000	M		TO ORDER AS CUT GOODS
	36	7.314-944.0	Spring pin 5x24-St ISO 8752	2.000	ST		

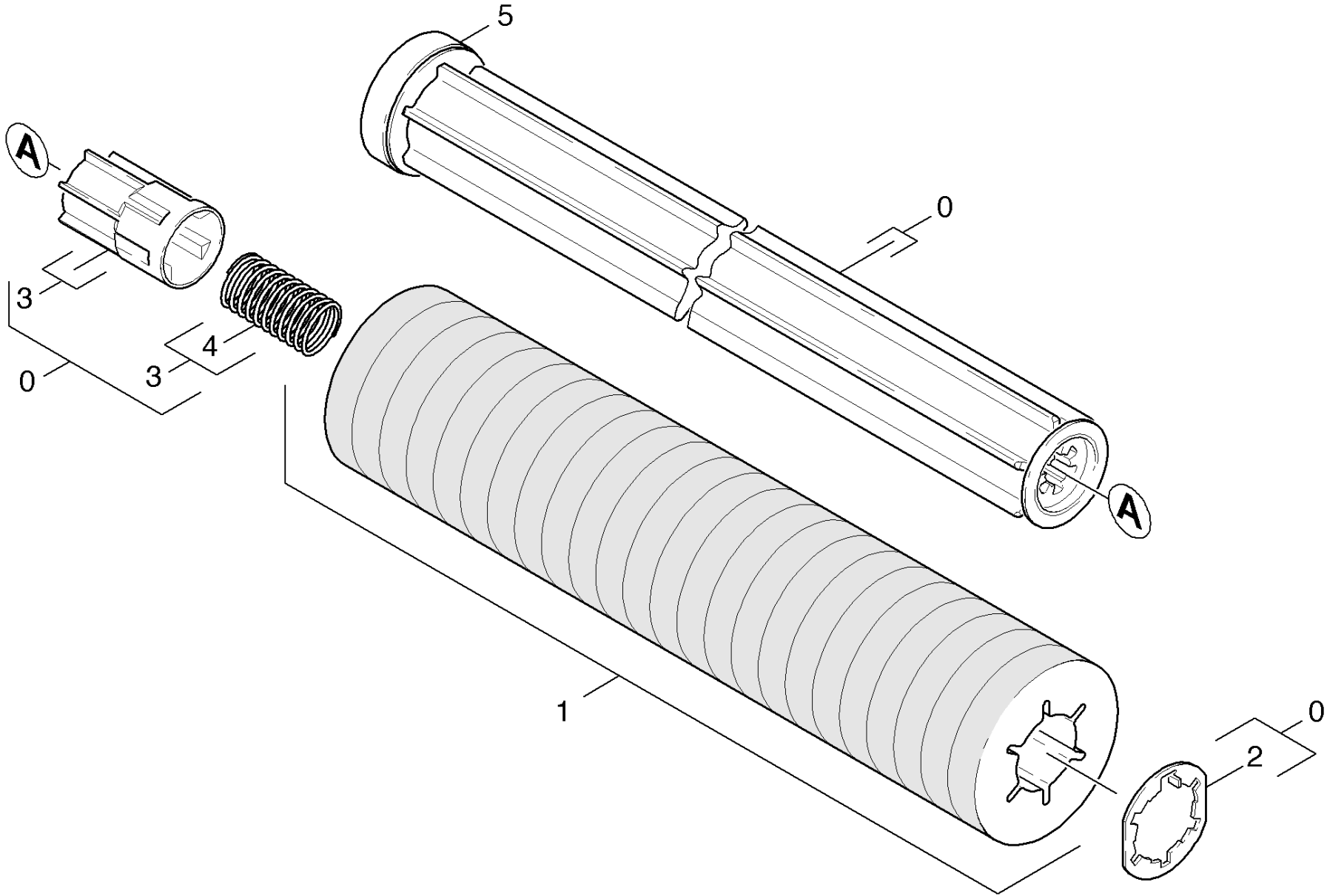

40 Accessories pad roll (0.162-883.0)

ET/VT (spare/wear parts)	Pos	Material #	Name	Qty.	Unit	from ser.nr.	up to ser.nr.
X-X	0	4.762-228.0	Roll Pad BR VS 400	1.000	ST	0000000000	0000000000
X-X	1	6.369-726.0	Pad red with sleeve	1.000	ZSA	0000000000	0000000000
	1	6.369-727.0	Pad white with sleeve BR VS 400	1.000	ZSA	0000000000	0000000000
X-X	1	6.369-724.0	Pad yellow with sleeve	1.000	ZSA	0000000000	0000000000
X-X	1	6.369-725.0	Pad green with sleeve	1.000	ZSA	0000000000	0000000000
	2	4.115-003.0	Washer closure	1.000	ST	0000000000	0000000000
	3	5.120-313.0	Hub pad roll BR VS	1.000	ST	0000000000	0000000000
	4	5.332-469.0	Helical spring	1.000	ST	0000000000	0000000000
X-X	5	4.038-677.0	Sheet metal component thread deflector	1.000	ST	0000000000	0000000000