



# **Spare Parts List**

**(1.008-025.0)**

**Clipper 12 115V**

From Serial Number (Ref No1\*)

\*See Serial Number Page  
or call manufacturer

## *How to Use this Spare Parts List*

---

The PARTS LIST section contains assembled parts illustrations and corresponding parts list. The parts lists include a number of columns of information:

- REF - column refers to the reference number on the parts illustration.
- PART NO. - column lists the part number for the part.
- QTY - column lists the quantity of the part used in that area of the machine.
- DESCRIPTION - column is a brief description of the part.
- SERIAL NO. FROM - If this column has an (\*) and a Reference number, see the SERIAL NUMBERS page in the back of your manual. If column has two asterisk (\*\*), call manufacturer for serial number. The serial number indicates the first machine the part number is applicable to. The main illustration shows the most current design of the machine. When a boxed illustration is shown, it displays the older design.
- NOTES - column for information not noted by the other columns.

**NOTE:** *If a service or option kit is installed on your machine, be sure to keep the KIT INSTRUCTIONS which came with the kit. It contains replacement parts numbers needed for ordering future parts.*

<b>How to Use this Spare Parts List</b> .....	<b>2</b>
<b>Table of Contents</b> .....	<b>3</b>
Frame Assembly .....	4
Brush Assembly .....	6
Pump .....	8
Vacuum Shoe .....	10
Control Panel .....	12
Solution Tank & Vacuum .....	14
Recovery Tank .....	16
Wiring Diagram .....	18
Serial Number .....	19



REF	PART NO.	QTY	DESCRIPTION	SERIAL NO. FROM	NOTES
1	86300070	2	HUBCAP, 9.75" WHEEL, BLACK		
2	86033080	1	FRAME, CLIPPER 12		
3	86004340	1	HOSE ASM, 1.5 BLK VAC X 15.5		
4	86001660	2	HUBCAP, 5/8" SHAFT		
5	86238820	1	HARNESS, MAIN, CLP/ADM		
6	86239610	1	HINGE, TANK TO FRAME		
7	86026150	1	MOTOR ASM, BRUSH CLP FAMILY		
8	86005640	10	NUT, 10-32 HEX NYLOCK		
9	86005810	3	NUT, 1/4-20 HEX NYLOCK SS		
10	86198530	2	FOAM TAPE, 1/8 THK X 3/4 1SDA		
11	86249430	1	PLATE, BRUSH MTR CLAMP		
12	86006020	1	PULLEY, 1.4 OD, 6GR, MICRO-V		
13	86254480	2	SPACER, HANDLE PIVOT		
14	86238200	2	GEAR, 40 TOOTH		
15	86006580	2	SCR, 1/4-20 X 1/2 PPHMS SS		
16	86273980	10	SCR, 10-32 X 3/4 PPHMS		
17	86005710	3	NUT, 1/4-20 HEX W/ STAR WASHER		
18	86010630	2	WASHER, 1/4 ID X 5/8 OD SS		
19	86010660	2	WASHER, 1/4 LOCK EXT STAR SS		
20	86010650	10	WASHER, #10 X 9/16 OD		
21	86006550	2	SET SCR, 10-32 X 1/4 KCP		
22	86256190	1	STRAIN RELIEF, 90 DEGREE		
23	86276610	1	SCR, 1/4-20 X 1.25 PPHMS SS		
24	86226050	2	WHEEL, 9.75" X 1.5"		
25	86066230	1	AXLE, 5/8 X 17.06L		
26	86134490	10	HEAT SHRINK, 3/4 ID UL/CSA		
27	86253090	1	SEAL, FRAME/TANK		
28	86233140	1	CLAMP, 2.0" WORM GEAR		
29	86276500	6	SCR, 5/16-18 X 3.5 SHCS PLATED		
30	86279130	6	WASHER, 5/16 SPLIT LOCK PLTD		
31	86069290	1	BRKT, CLP HANDLE SUPPORT		
32	86069300	1	BRKT, CLP HANDLE SUPPORT LT		
33	86274760	2	SCR, 1/4-20 X 1/2 HHCS PLTD		
34	86006530	2	SCR, 1/4-20 X 1 PPHMS SS		
35	86272160	1	PIN, ROLL 1/8" X 1.0"L		

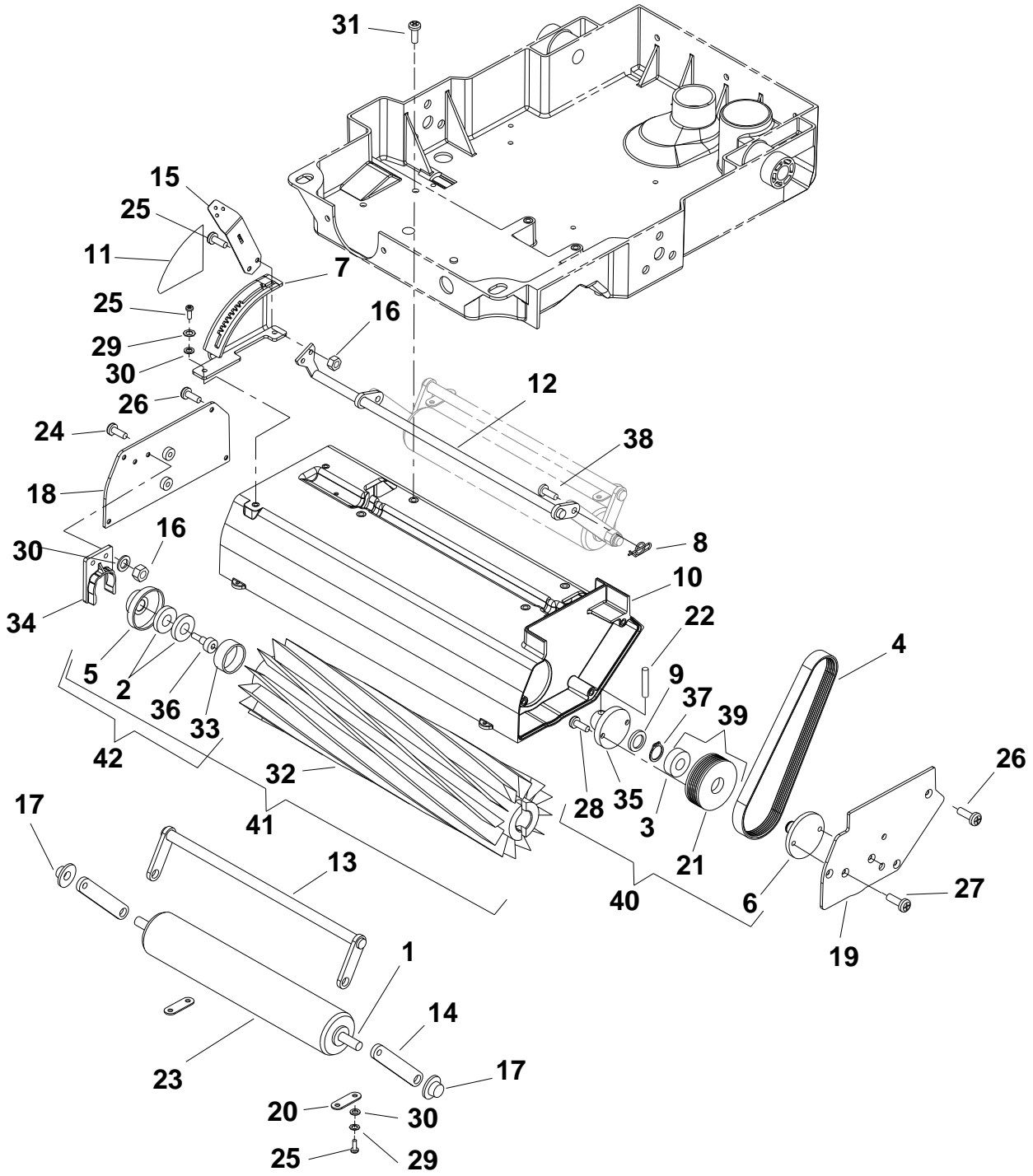

REF	PART NO.	QTY	DESCRIPTION	SERIAL NO.FROM	NOTES
1	86000730	1	AXLE, ROLLER		
2	86228890	2	BEARING, R6 3/8 ID		
3	86000900	2	BEARING, 1.125ODX.500IDX.375		
4	86001100	1	BELT, 180J6 MICRO-V		
5	86227150	1	ADAPTER, BRUSH BRG. DIE CAST		
6	86001300	1	BRKT, BRUSH PULLEY		
7	86001310	1	BRKT, BRUSH HEIGHT		
8	86008650	2	COTTER, 1/4" RING		
9	86342240	1	SPACER, .81 X 1.06 X .125		
10	86240970	1	HOUSING, BRUSH, 18"		
11	86396740	1	LABEL, BRUSH HEIGHT		
12	86093080	1	LINKAGE, ASM, BRUSH HEIGHT		
13	86005110	1	LINKAGE ASM, ROLLER SUPPORT		
14	86005120	2	LINK, ROLLER, FRONT		
15	86005130	1	LEVER, HEIGHT ADJUSTMENT		
16	86005640	4	NUT, 10-32 HEX NYLOCK		
17	86005850	2	NUT, 3/8 DIA CAP, TYPE PUSH PLT		
18	86249410	1	PLATE, BRUSH HOUSING RH		
19	86249420	1	PLATE, BRUSH HOUSING LH		
20	86005930	2	PLATE, AXLE RETAINER		
21	86250680	1	PULLEY, 2.2 OD, 6GR, MICRO-V		
22	86006220	1	PIN, ROLL 1/4 X 1.25L		
23	86006430	1	ROLLER, 1.9 DIA X 10.5 LG		
24	86006510	2	SCR, 10-32 X 5/8 PFHMS		
25	86006590	6	SCR, 10-32 X 1/2 PPHMS SS DL		
26	86006650	7	SCR, 10-32 X 1/2 FHMS SS		
27	86006700	2	SCR, 10-32 X 3/8 FHMS SS		
28	86275530	2	SCR, #10-24 X 1/2 SHCS		
29	86010640	4	WASHER, #10 LOCK EXT STAR SS		
30	86010650	6	WASHER, #10 X 9/16 OD		
31	86007030	4	SCREW, 1/4-20 X .625 PHTRHMS STL DL		
32	86230630	1	BRUSH, 18L X 3.38 OD G2		
33	86251710	1	RING, TOLERANCE 7/8 ID X 1/2 W		
34	86003070	1	CLIP, BEARING		
35	86003370	1	DRIVER, BRUSH		
36	86278130	1	SHLDR BOLT, 3/8 OD X 3/8 L SS NP		
37	86272770	1	RING, 1/2 EXT. SNAP		
38	86272510	2	PIN, CLEVIS 1/4 X 1/2 PLTD		
39	86006030	1	PULLEY ASM, BRUSH		
40	86003390	1	DRIVER ASM, BRUSH		
41	86001150	1	BRUSH ASM, 18 IN		
42	86004750	REF	KIT,BRNG/ADPTR EXTRCTR		

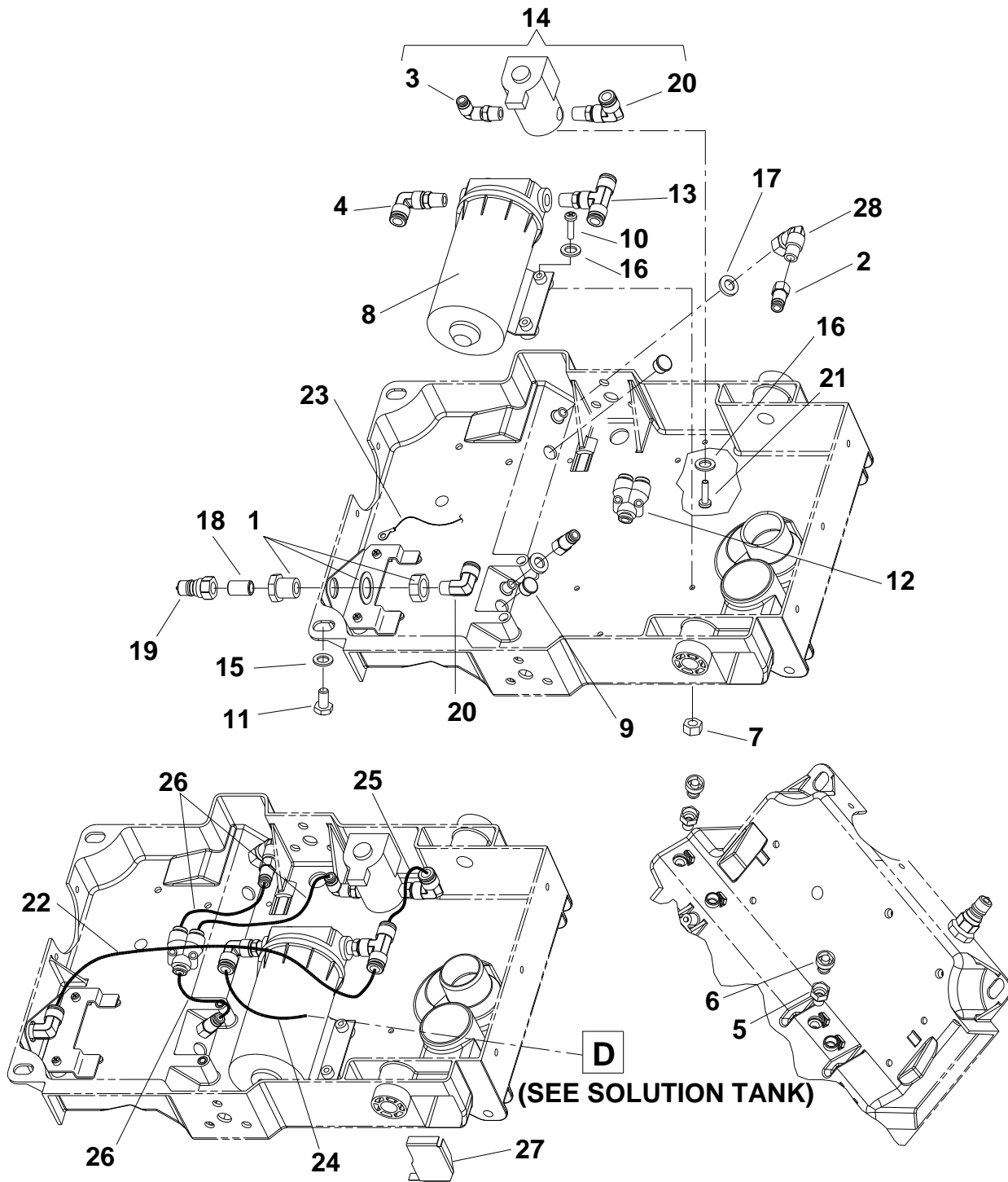



REF	PART NO.	QTY	DESCRIPTION	SERIAL NO. FROM	NOTES
1	86002470	1	COUPLING, 1/4 ANCHOR W/1" HEX		
2	86002480	2	CONNECTOR, 1/8FPT X 1/4 TUBEQC		
3	86003470	1	ELBOW, SWIVEL, 1/4MPTX1/4TUBE		
4	86003490	1	ELBOW, SWIVEL, 3/8MPTX3/8TUBEQC		
5	86004570	2	JET BODY, MINI PROMAX BODY		
6	86004580	2	JET, MINI PROMAX 9504		
7	86005640	2	NUT, 10-32 HEX NYLOCK		
8	86026390	1	PUMP ASM, 115V 100 PSI W/CONN		
9	86250140	2	PLUG, 9/16 OD BLK NYLON		
10	86274410	2	SCR, 10-32 X 1.25 PPHMS		
11	86273750	2	SCR, 1/4-20 X 5/8 HHCS SS		
12	86003640	1	FITTING, 1/4 TUBE,"Y", QC		
13	86008360	1	TEE, 3/8 MPT X 3/8 TUBE, QC		
14	86026940	1	VALVE ASM, SOLENOID CLP FAMILY		
15	86010810	2	WASHER, 1/4"IDX1.0OD. FLAT SS		
16	86010650	4	WASHER, #10 X 9/16 OD		
17	86010820	2	WASHER, 7/16 X 3/4 X .19RUBBER		
18	86005590	1	NIPPLE, 1/4 CLOSE		
19	86005580	1	NIPPLE, 1/4 FPT QD		
20	86003500	2	ELBOW, 1/4 MPT X 3/8 TUBE, QC		
21	86274290	2	SCR, 10-32 X 3/8 PPHMS SS		
22	86004400	1	HOSE, 3/8 ID NYL11 YLW X 29"		
23	86267400	1	WIRE, 22" GRN/18 76011 X 76011		
24	86281890	1	HOSE, 3/8 URETHANE X 29"		
25	86004350	1	HOSE, 3/8 NYLON X 6"		
26	86281900	3	HOSE, 1/4 URETHANE X 6"		
27	86253020	1	SCREEN, INTAKE		
28	86197400	1	ELBOW, 1/8NPT STREET		

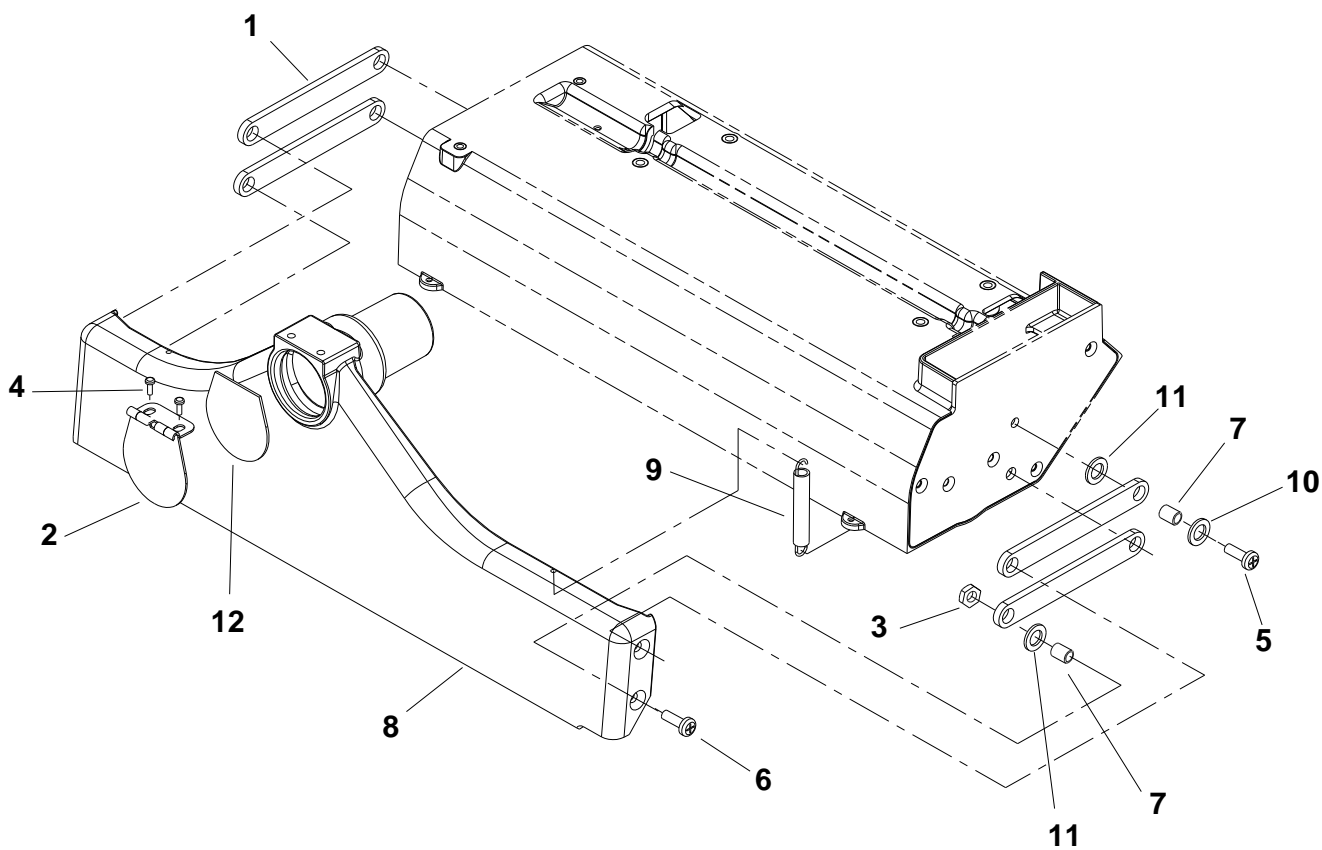

REF	PART NO.	QTY	DESCRIPTION	SERIAL NO.FROM	NOTES
1	86227350	4	ARM, VAC SHOE PARALLEL		
2	86234760	1	COVER, ACCESSORY PORT		
3	86005810	4	NUT, 1/4-20 HEX NYLOCK SS		
4	86006790	2	SCR, 10-32 X 3/8 HHTR W/STAR		
5	86275120	4	SCR, 1/4-20 X.75 PPHMS PHIL		
6	86006840	4	SCR, 1/4-20 X 1 FHCS PLTD		
7	86008130	8	SPACER, 3/8ODX.058WX.2814,CRS		
8	86258630	1	VAC SHOE, 18"		
9	86008120	2	SPRING, EXT .38D X2.75L X.055W		
10	86010630	4	WASHER, 1/4 ID X 5/8 OD SS		
11	86010700	8	WASHER, WAVE 3/8ID X3/4D X.125		
12	86003780	1	GASKET, ACCESSORY PORT		

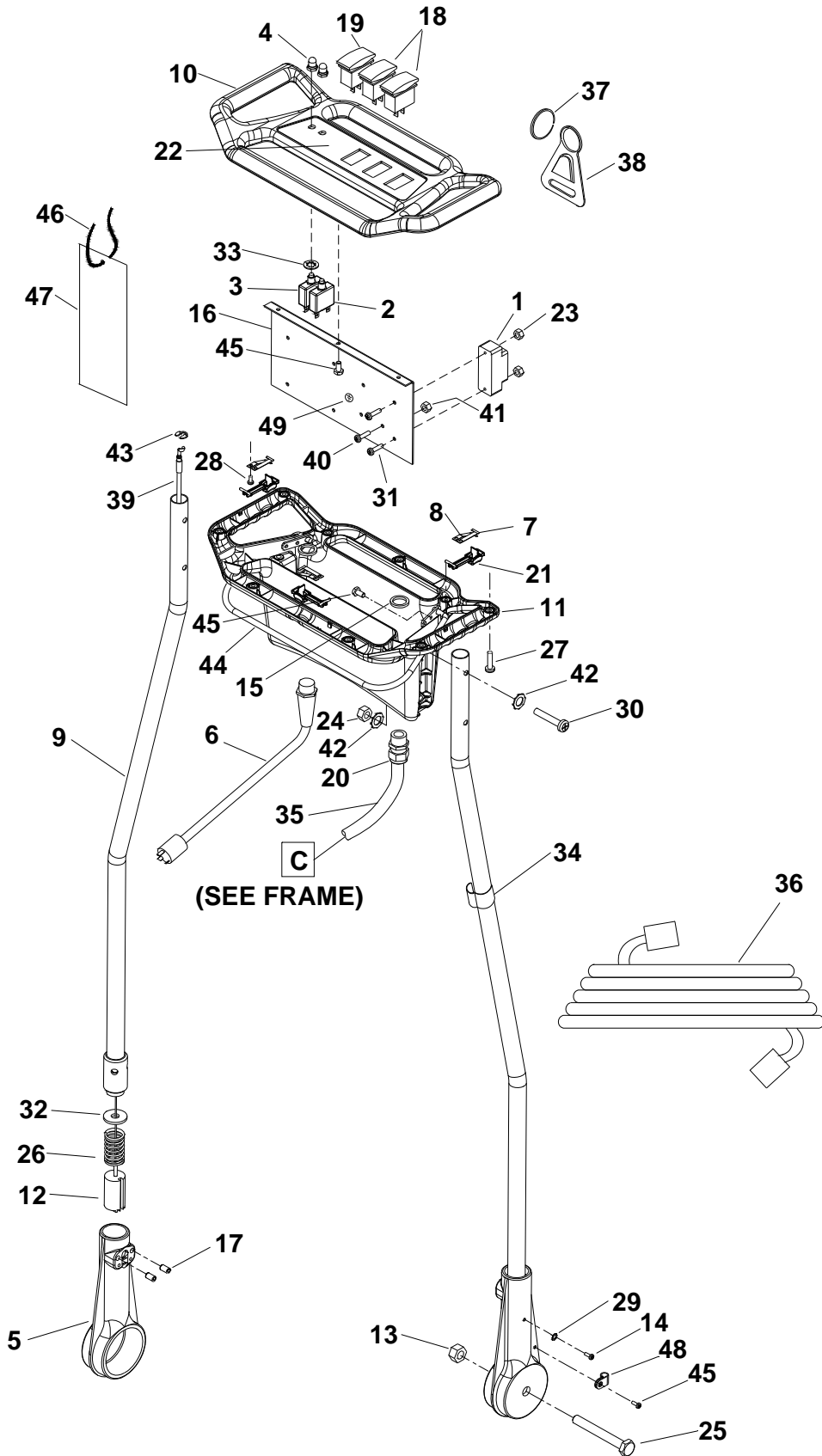

REF	PART NO.	QTY	DESCRIPTION	SERIAL NO. FROM	NOTES
1	86001240	1	TERMINAL BLOCK, 115V (3-4-3)		
2	86001980	1	BREAKER, 15A 250VAC 50VDC		
3	86230210	1	BREAKER, 6A VDE CIRCUIT		
4	86002010	2	BOOT, 3/8 CIRCUIT BREAKER		
5	86240890	2	HOUSING, CLP HANDLE PIVOT		
6	86234320	1	CORD ASM, 14/3 X 22" YLW		
7	86003130	3	CONTACT, ELECTRICAL, FLAT		
8	86003140	3	CONTACT, ELECTRICAL, BENT		
9	86004090	2	HANDLE, CLP12 WELDED		
10	86004100	1	HANDLE, CONTROL PANEL FRONT		
11	86004110	1	HANDLE, CONTROL PANEL REAR		
12	86005010	2	LOCK, HANDLE POSITION		
13	86005790	2	NUT, 1/2-13HEXNYLOCK THIN PLTD		
14	86273990	2	SCR, 6-32 X 3/8 PPHMS		
15	86005670	2	NUT, 1/2 NPT CONDUIT		
16	86081530	1	PLATE, CONTROL PANEL, CLP/ADM		
17	86277980	4	SET SCR, 5/16-18 X 1/2 CONE PT		
18	86007140	2	SWITCH, SPST 2-POSITION ROCKER		
19	86007200	1	SWITCH, DPDT3-POSITION ROCKER		
20	86256180	1	STRAIN RELIEF, 1/2 NPT (.48ID)		
21	86401390	3	TRIGGER, SWITCH		
22	86395800	1	LABEL, CONTROL PANEL, CLP/ADM		
23	86005760	2	NUT, 6-32 W/STAR WASHER PLTD		
24	86005810	4	NUT, 1/4-20 HEX NYLOCK SS		
25	86276510	2	SCR, 1/2-13 X 4.75HHCS GR5 PLT		
26	86226840	2	SPRING, COMP .88D X1.4L X.100W		
27	86006870	9	SCR, #10 X 3/4 PPHST TYPE B		
28	86006620	6	SCR, 6-32 X 1/4 PPHMS SS		
29	86279020	2	WASHER, #6 LOCK EXT STAR SS		
30	86274150	4	SCR, 1/4-20 X 1.75 PPHMS SS		
31	86006710	2	SCR, 6-32 X 1.0 PH BLK NYLON		
32	86010720	2	WASHER, M10 X 30 PLTD		
33	86010750	2	WASHER, 3/8 ID INT.LOCK THIN		
34	86198480	2	CLIP, POWER CORD		
35	86238820	REF	HARNESS, MAIN CLP/ADM		
36	86234110	1	CORD SET,14/3 SJTW-A X 50' YLW		
37	86272840	1	RING, 2" DIA SPLIT		
38	86256170	1	STRAIN RELIEF, CORD HOOK		
39	86003120	2	CABLE, .06 X 40, 0707, SS		
40	86006830	1	SCR, 10-32 X 1" PPHMS		
41	86005700	3	NUT, 10-32 W/STAR WASHER PLTD		
42	86010660	6	WASHER, 1/4 LOCK EXT STAR SS		
43	86006410	2	RING, 1/4 KLIP		
44	86092980	1	LEVER ASM, CLP HANDLE ADJ		
45	86006790	5	SCR, 10-32 X 3/8 HHTR W/STAR		
46	86002870	1	CORD, 99807 1/8 X 12"		
47	86396900	1	CARD, INSTRUCTION CLP12		
48	86002370	1	CLAMP, 7/16 DIA NYLON UL		
49	86245040	1	LABEL, GROUND SYMBOL		

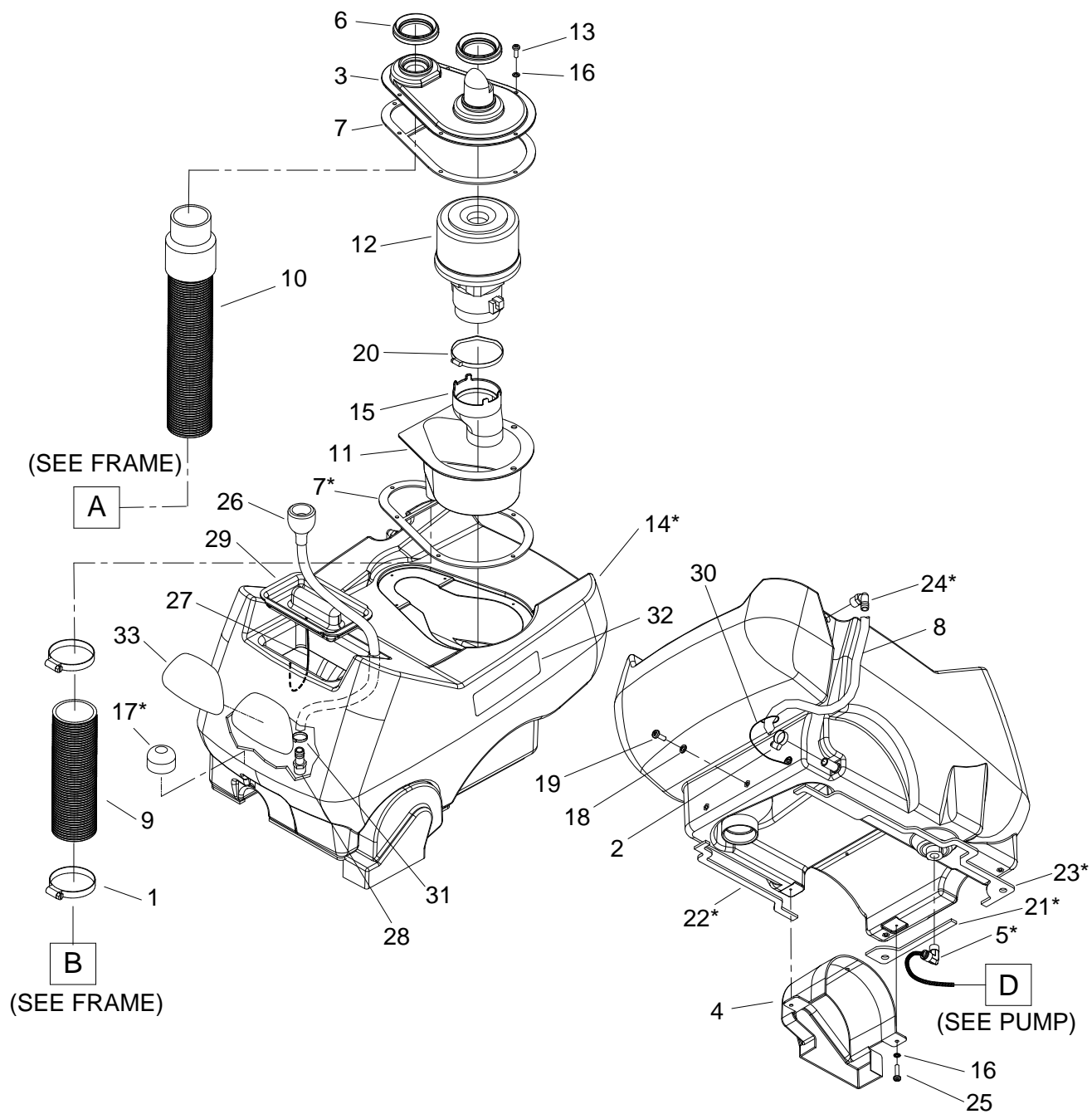

REF	PART NO.	QTY	DESCRIPTION	SERIAL NO. FROM	NOTES
1	86233140	2	CLAMP, 2.0" WORM GEAR		
2	86233150	1	CLAMP, 3/8 HOSE (D-SLOT)		
3	86003080	1	COVER, VAC MOTOR		
4	86003090	1	COVER, BELT		
5	86235500	1	ELBOW, 3/8 MPT X 3/8 TUBE, PLASTIC		
6	86003790	2	GASKET, TANK TO VAC COVER		
7	86003920	2	GASKET, VAC COVER (CLP FAMILY)		
8	86281880	1	HOSE, 1/2 CLEAR X 12		
9	86240100	1	HOSE, 1.5 BLK VAC X 5.0		
10	86004340	REF	HOSE ASM, 1.5 BLK VAC X 15.5		
11	86240980	1	HOUSING, VAC MOTOR		
12	86026880	1	VAC MOTOR ASM, CLP FAMILY		
-	86135320		BRUSH SET, 120V VAC, WINDSOR		SERVICE ONLY
13	86275690	6	SCR, #10 X 1.0 PPHST TYPE B		
14	86032280	1	TANK, CLP SOLUTION		
15	86259070	1	VENT, COOLING AIR LARGE		
16	86010650	8	WASHER, #10 X 9/16 OD		
17	86007970	1	STRAINER, 3/8 IN. NPT 60 MESH		
18	86010630	3	WASHER, 1/4 ID X 5/8 OD SS		
19	86006580	3	SCR, 1/4-20 X 1/2 PPHMS SS DL		
20	86233260	1	CLAMP, 3.5" WORM GEAR		
21	86003950	1	GASKET, TANK, L-F		
22	86003960	1	GASKET, TANK, L-R		
23	86003970	1	GASKET, TANK, RH		
24	86197940	1	HOSEBARB, 3/8MPTX1/2 90D DL		
25	86006600	2	SCR, #10 X 3/4 PPHST TYPE B		
26	86260690	1	HOSE ASSY- FILL HOSE		
27	86002870	1	CORD, 99807 1/8 X 12"		
28	86197920	1	HOSEBARB, 1/2MPT X 3/8 DL		
29	86234790	1	COVER, CLP SOLUTION		
30	86246060	1	LANYARD, .06 X 2.88		
31	86233090	1	CLAMP 1/4 ID HOSE		
32	86395820	2	LABEL, CLIPPER SIDE		
33	86395400	1	LABEL, WINDSOR LOGO DOMED		
-	86026680	1	TANK ASM, SOLUTION CLP12		INCLUDES 5, 7, 14, 17, 21, 22, 23 AND 24

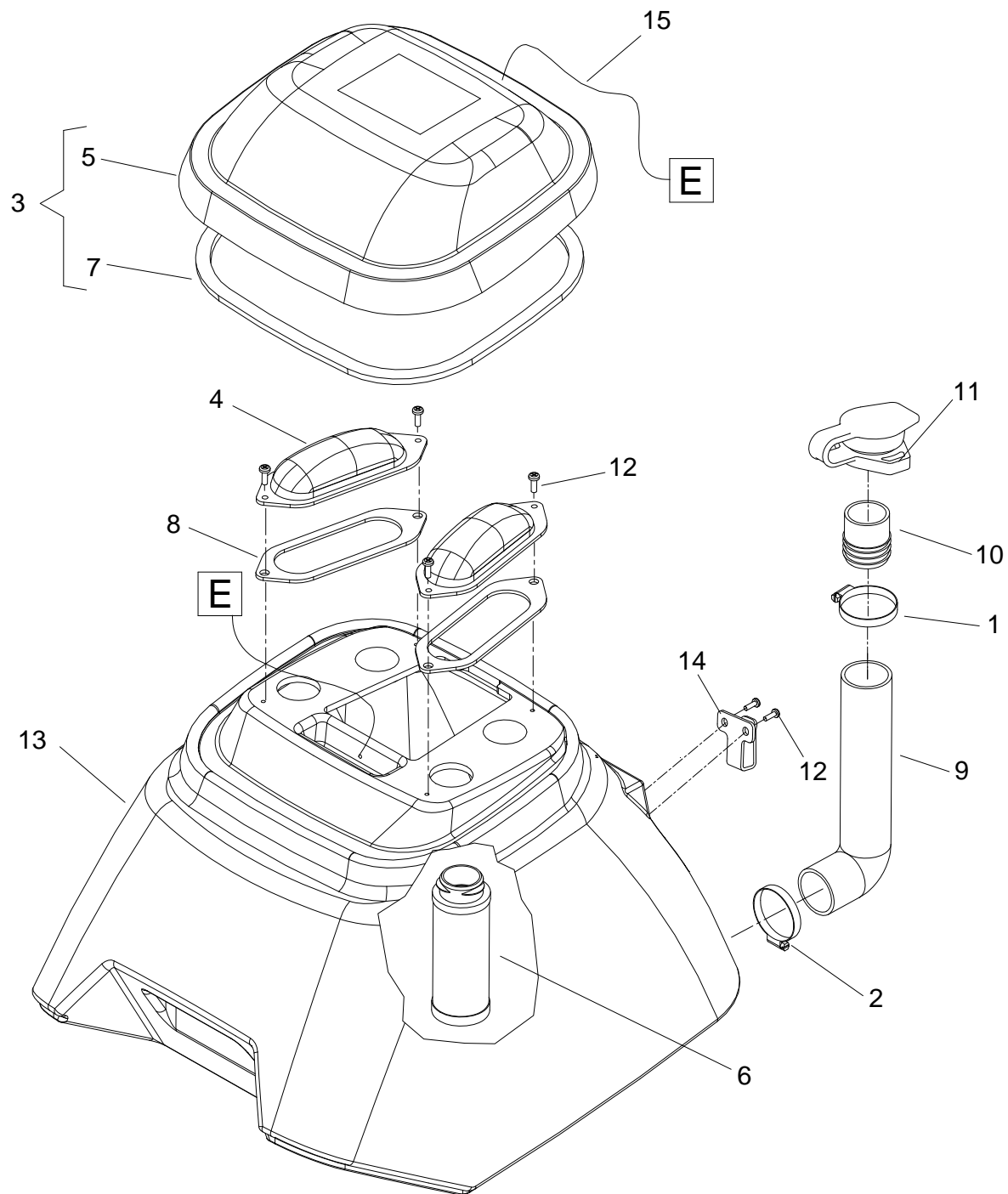



REF	PART NO.	QTY	DESCRIPTION	SERIAL NO.FROM	NOTES
1	86002400	1	CLAMP, 2.0" WORM GEAR X .312		
2	86233140	1	CLAMP, 2.0" WORM GEAR		
3	86003330	1	DOME ASM, CLP FAM		
4	86003110	2	COVER, REC. TANK		
5	86235280	1	DOME, S/C EXTRACTORS		
6	86003630	1	FLOAT SHUT-OFF		
7	86003910	1	GASKET, DOME		
8	86003930	2	GASKET, PORT COVER		
9	86004200	1	HOSE, 1.5 X 12.0 DRAIN		
10	86004510	1	HOSE, INSERT		
11	86401400	1	HOSE, CAP		
12	86006600	6	SCR, #10 X 3/4 PPHST TYPE B		
13	86032290	1	TANK, CLP RECOVERY		
14	86001370	1	BRKT, HOSE HOOK		
15	86002870	1	CORD, 99807 1/8 X 12"		

# Wiring Diagram

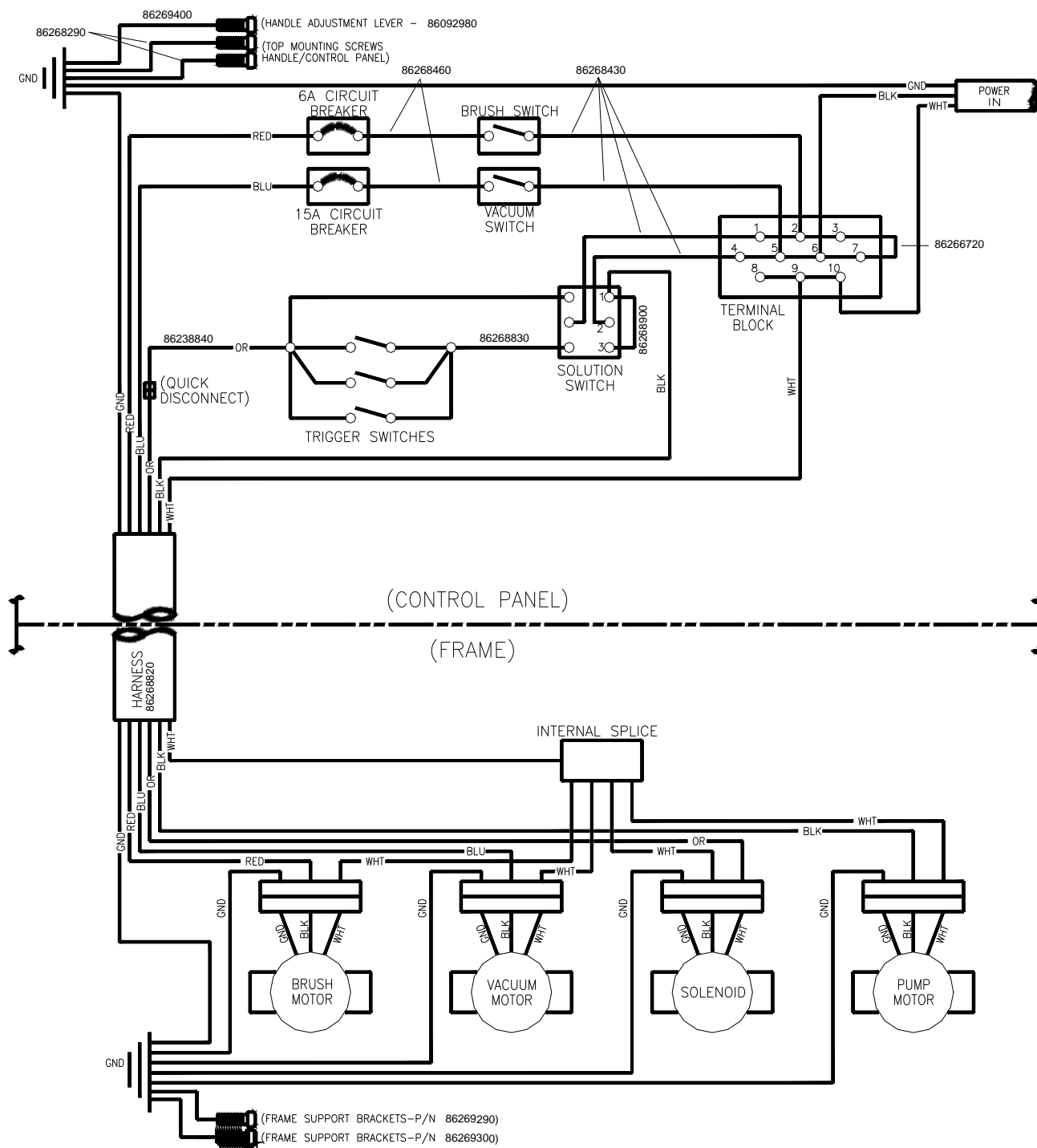

REF. NO.	MODEL: SERIAL #
1	N/A