

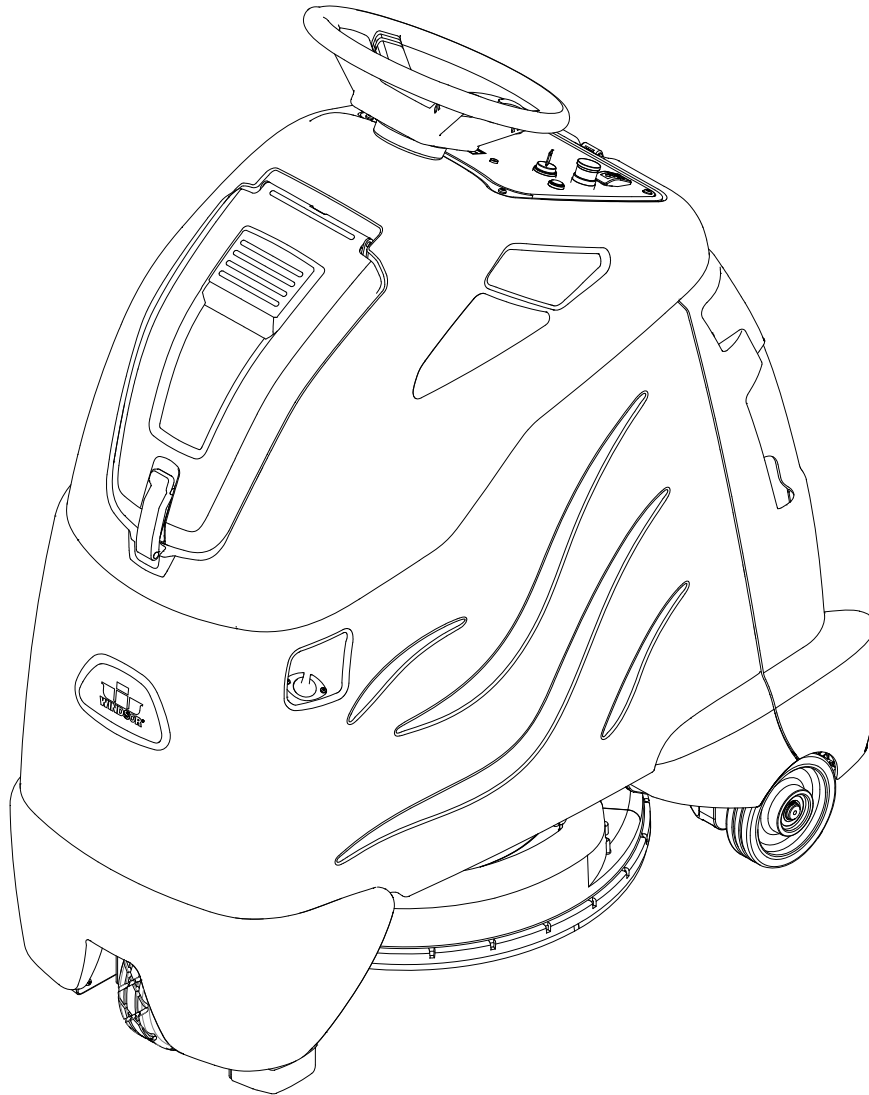

Chariot[®] 2

iGloss 20

Operating instructions (ENG)



MODELS: **CBPS20**
10020310

CBPSC20
10020320

CBPL20
10020330

CBPLC20
10020340

CBAL20
10020350

CBALC20
10020360

Prior to Serial Number (Ref No. 10*)
See Serial number page or call
manufacturer.

Read these instructions before using the machine.



Model: _____

Date of Purchase: _____

Serial Number: _____

Dealer: _____

Address: _____

Phone Number: _____

Sales Representative: _____

Overview

The Chariot iGloss 20 burnisher is a battery powered, ride-on, hard floor burnisher intended for commercial use. This machine applies a high luster to hard floor surfaces.

Warranty Registration

Thank you for purchasing a Windsor product. Warranty registration is quick and easy. Your registration will allow us to serve you better over the lifetime of the product.

To register your product go to :
www.windsorind.com/WarrantyRegistration.aspx
For customer assistance:
1-800-444-7654



Machine Data Label2
 Overview2
Table of Contents3
How To Use This Manual4

Safety

IMPORTANT SAFETY INSTRUCTIONS5
 HAZARD INTENSITY LEVEL7
 SAFETY LABEL LOCATIONS9

Operation

Technical Specifications10
 How This Machine Works12
 Components13
 Pre-Run Machine Inspection20
 Starting Machine20
 Emergency Stop Procedure20
 Operating the Machine21
 Normal Burnishing21

Maintenance

Service Schedule22
 Checking Battery Specific Gravity26
 Changing Batteries28
 Battery Charger Programming29
 Burnishing Pad31
 Burnisher Motor Carbon Brush Ring Replacement32
 Deck Actuator Removal / Replacement32
 Vacuum - Optional34
 Body Assembly Removal36
 Drive Unit Removal36
 Drive Motor38
 Drive Motor Carbon Brush Replacement38
 Drive Chain Tension38
 Inclines39
 Machine Tie-Downs40
 Troubleshooting41

Parts

Body Brace46
 Body Lower48
 Body Lower Mounting50
 Bumper52
 Burnishing Deck54
 Burnishing Deck Mounting56
 Burnishing Deck Lift58
 Burnishing Deck - Pad Driver60
 Console - Bag Enclosure62
 Console - Hinge64
 Control Panel66
 Control Panel68
 Charger-Optional70
 Decals72
 Drive-Chain74
 Drive-Lower76
 Drive Mounting78
 Frame & Rear Wheels80
 Pedal Platform82
 Pedal Platform Mounting84
 Steering86
 Vacuum-Optional88
 Wiring-Battery90
 Wiring Diagram 192
 Wiring Diagram 294
 Wiring Diagram 396
 Wiring Diagram 498
 Wiring Diagram 5100
 Wiring Diagram 6102
 Wiring Diagram 7104
 Wiring Diagram 8106
 Suggested Spare Parts108

How To Use This Manual

This manual contains the following sections:

- HOW TO USE THIS MANUAL
- SAFETY
- OPERATIONS
- MAINTENANCE
- PARTS LIST

The HOW TO USE THIS MANUAL section will tell you how to find important information for ordering correct repair parts.

Parts may be ordered from authorized Windsor dealers. When placing an order for parts, the machine model and machine serial number are important. Refer to the MACHINE DATA box which is filled out during the installation of your machine. The MACHINE DATA box is located on the inside of the front cover of this manual.

Model:	_____
Date of Purchase:	_____
Serial Number:	_____
Dealer:	_____
Address:	_____
Phone Number:	_____
Sales Representative:	_____

The model and serial number of your machine are located below the battery compartment of the machine.

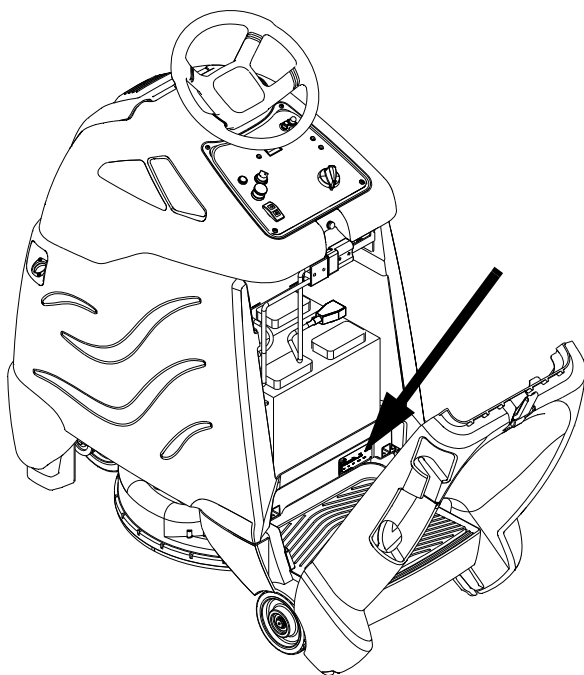

The SAFETY section contains important information regarding hazard or unsafe practices of the machine. Levels of hazards are identified that could

result in product or personal injury, or severe injury resulting in death.

The OPERATIONS section is to familiarize the operator with the operation and function of the machine.

The MAINTENANCE section contains preventive maintenance to keep the machine and its components in good working condition. They are listed in this general order:

- Batteries
- Brush Deck
- Circuit Protection
- Drive Motor and Brake
- Service Schedule
- Vacuum Motor
- Machine Troubleshooting

The PARTS LIST section contains assembled parts illustrations and corresponding parts list. The parts lists include a number of columns of information:

REF - column refers to the reference number on the parts illustration.

PART NO. - column lists the part number for the part.

PRV NO. - Reference No.

QTY - column lists the quantity of the part used in that area of the machine.

DESCRIPTION - column is a brief description of the part.

SERIAL NO. FROM - If this column has an (*) and a Reference number, see the SERIAL NUMBERS page in the back of your manual. If column has two asterisk (**), call manufacturer for serial number.

The serial number indicates the first machine the part number is applicable to. The main illustration shows the most current design of the machine.

When a boxed illustration is shown, it displays the older design.

NOTES - column for information not noted by the other columns.

NOTE: If a service or option kit is installed on your machine, be sure to keep the KIT INSTRUCTIONS which came with the kit. It contains replacement parts numbers needed for ordering future parts.

The number on the lower left corner of the front cover is the part number for this manual.

IMPORTANT SAFETY INSTRUCTIONS

When using an electrical appliance, basic precaution must always be followed, including the following:

READ ALL INSTRUCTIONS BEFORE USING THIS MACHINE.

⚠ WARNING: To reduce the risk of fire, electric shock, or injury:

Use only indoors. Do not use outdoors or expose to rain.

Use only as described in this manual. Use only manufacturer's recommended components and attachments.

If the machine is not working properly, has been dropped, damaged, left outdoors, or dropped into water, return it to an authorized service center.

Do not operate the machine with any openings blocked. Keep openings free of debris that may reduce airflow.

This machine is not suitable for picking up hazardous dust.

Machine can cause a fire when operating near flammable vapors or materials. Do not operate this machine near flammable fluids, dust or vapors.

This machine is suitable for commercial use, for example in hotels, schools, hospitals, factories, shops and offices for more than normal housekeeping purposes.

Maintenance and repairs must be done by qualified personnel.

Disconnect battery before cleaning or servicing.

Before the machine is discarded, the batteries must be removed and properly disposed of.

Make sure all warning and caution labels are legible and properly attached to the machine.

During operation, attention shall be paid to other persons, especially children.

Before use all covers and doors shall be put in the positions specified in the instructions.

When leaving unattended, secure against unintentional movement.

The machine shall only be operated by instructed and authorized persons.

When leaving unattended, switch off or lock the main power switch to prevent unauthorized use.

This appliance has been designed for use with the pads specified by the manufacturer. The fitting of other pads may affect its safety.

Do not use on surfaces having a gradient of over 10% (6 degrees).

SAVE THESE INSTRUCTIONS

MESURES DE SÉCURITÉ IMPORTANTES

Lors de l'utilisation d'un appareil à batteries, il est nécessaire de respecter systématiquement des mesures de sécurité de base, comme suit :

⚠ AVERTISSEMENT: PRENEZ NOTE DE TOUTES CES MESURES AVANT D'UTILISER CETTE MACHINE.

Pour réduire les risques d'incendie, de chocs électriques, ou de blessures :

N'utiliser cette machine qu'en intérieur. Ne jamais l'utiliser à l'extérieur ou dans la pluie.

N'utiliser cette machine que comme décrit dans le présent manuel. N'utiliser que les composants et les accessoires conseillés par le fabricant.

Lorsque la machine ne fonctionnant pas correctement, a fait l'objet d'une chute ou d'une détérioration, a été laissée à l'extérieur, est tombée dans l'eau, la retourner au centre de service agréé.

Ne pas opérer la machine lorsque les conduits de ventilation sont bloquées. Débarrasser les débris des conduits, car ils peuvent réduire l'écoulement d'air.

Cette machine n'est pas adaptée au ramassage de poussières dangereuses

Cette machine peut provoquer un incendie lorsqu'elle est utilisée près de vapeurs ou de matériaux inflammables. Ne pas l'utiliser près de liquides, de poussières ou de vapeurs inflammables.

Cette machine est destinée à un usage commercial. Elle est recommandée davantage pour les domaines hôtelier, scolaire, hospitalier, industriel ou pour les bureaux, les chaînes de magasin, que pour un usage domestique normal.

L'entretien et les réparations de la machine doivent être effectuées par un personnel qualifié.

Si de la mousse ou du liquide sort de la machine, la mettre hors tension immédiatement.

Déconnecter les batteries avant de nettoyer la machine ou de la soumettre à un entretien.

Avant de se débarrasser de la machine, il est nécessaire de retirer les batteries et de les jeter correctement.

S'assurer que toutes les plaques d'avertissement ou de précaution sont lisibles et fixées correctement sur la machine.

Durant la manoeuvre de la machine, prendre garde aux personnes environnantes et notamment aux enfants.

Avant l'utilisation de la machine, veiller à positionner tous les couvercles et portes comme indiqué dans les instructions.

Lorsque la machine est laissée sans surveillance, s'assurer qu'elle ne se déplace pas de manière accidentelle.

Cette machine ne doit être manoeuvrée que par un personnel expérimenté et qualifié.

Lorsque la machine est laissée sans surveillance, la mettre hors tension ou verrouiller l'interrupteur principal afin d'empêcher un emploi non autorisé.

Seuls les produits chimiques recommandés par le fabricant doivent être utilisés.

Cette machine a été conçue pour être utilisée avec des garnitures spécifiées par le fabricant.

L'utilisation d'autres garnitures peut affecter sa sûreté.

N'employez pas sur des surfaces ayant un gradient de plus de 10% (6 degrés).

CONSERVER CES INSTRUCTIONS

The following symbols are used throughout this guide as indicated in their descriptions:

HAZARD INTENSITY LEVEL

There are three levels of hazard intensity identified by signal words -**WARNING** and **CAUTION** and **FOR SAFETY**. The level of hazard intensity is determined by the following definitions:

WARNING:

WARNING - Hazards or unsafe practices which COULD result in severe personal injury or death.

CAUTION:

CAUTION - Hazards or unsafe practices which could result in minor personal injury or product or property damage.

FOR SAFETY: To Identify actions which must be followed for safe operation of equipment.

Report machine damage or faulty operation immediately. Do not use the machine if it is not in proper operating condition. Following is information that signals some potentially dangerous conditions to the operator or the equipment. Read this information carefully. Know when these conditions can exist. Locate all safety devices on the machine. Please take the necessary steps to train the machine operating personnel.

FOR SAFETY:

DO NOT OPERATE MACHINE:

Unless Trained and Authorized.

Unless Operation Guide is Read and understood.

In Flammable or Explosive areas.

In areas with possible falling objects.

WHEN SERVICING MACHINE:

Avoid moving parts. Do not wear loose clothing; jackets, shirts, or sleeves when working on the machine. Use Windsor approved replacement parts.

WARNING:

Batteries emit hydrogen gas. Explosion or fire can result. Keep sparks and open flame away. Keep battery compartment open during charging. Keep sparks and flames away from the batteries. Do not smoke around batteries.

WARNING:

Disconnect batteries before working on machine. Only qualified personnel should work inside machine. Always wear eye protection and protective clothing when working on or near batteries. Avoid skin contact with the acid contained in the batteries.

WARNING:

Never allow metal to lie across battery tops.

Les symboles ci-dessous sont utilisés à travers ce manuel comme illustré dans leurs descriptions :

DEGRÉS DE RISQUES EN CAS DE DANGER

Il existe trois degrés de risques identifiés par les termes signalétiques -AVERTISSEMENT et ATTENTION et POUR VOTRE SÉCURITÉ. Le degré de risque est défini de la manière suivante:

⚠ AVERTISSEMENT:

AVERTISSEMENT - Dangers ou méthodes dangereuses qui POURRAIENT provoquer de graves blessures ou entraîner la mort.

⚠ ATTENTION:

ATTENTION - Dangers ou méthodes dangereuses qui pourraient provoquer des blessures légères ou une détérioration du produit ou des biens immobiliers.

POUR VOTRE SÉCURITÉ: ce signe permet d'identifier les mesures de précaution à prendre pour assurer un bon fonctionnement du matériel.

Rendre compte immédiatement d'une défaillance ou d'une détérioration de la machine. Ne pas utiliser la machine si celle-ci ne fonctionne pas correctement. Lire soigneusement les informations ci-dessous signalant certains dangers potentiels pour l'opérateur de la machine. L'opérateur doit être absolument au courant de ces dangers potentiels. Localiser tous les dispositifs de sécurité sur la machine. Il est conseillé de prendre les mesures nécessaires pour former le personnel opérateur.

POUR VOTRE SÉCURITÉ:

NE PAS MANOEUVRER LA MACHINE:

Lorsqu'on n'est pas expérimenté ou qualifié.

Lorsque le guide d'utilisation n'est pas été lu ou compris.

Dans des zones inflammables ou explosives.

Dans des zones où des objets peuvent tomber.

LORS DE L'ENTRETIEN DE LA MACHINE:

Éviter les parties amovibles. Ne pas porter de vêtements amples, tels que des vestes, des chemises ou des vêtements avec manches lors de l'utilisation de la machine. Utiliser les pièces détachées Windsor homologuées.

⚠ AVERTISSEMENT:

Les batteries émettent le gaz d'hydrogène. L'explosion ou le feu peut résulter. Étincelles de subsistance et flamme nue loin. Compartiment de batterie de subsistance ouvert en chargeant. Étincelles et flammes de subsistance loin des batteries. Ne fumez pas autour des batteries.

⚠ AVERTISSEMENT:

Déconnecter les batteries avant de travailler sur la machine. La machine ne doit être confiée qu'à un personnel qualifié. Porter systématiquement des lunettes et des vêtements de protection lors d'une intervention sur les batteries ou aux alentours. Éviter tout contact de la peau avec l'acide contenu dans les batteries.

⚠ AVERTISSEMENT:

Ne jamais placer d'objets métalliques sur le dessus des batteries.

SAFETY LABEL LOCATIONS

These drawings indicate the location of safety labels on the machine. If at any time the labels become illegible, promptly replace them.

EMPLACEMENT DE L'ÉTIQUETTE DE SÉCURITÉ

REMARQUE : Ces dessins indiquent l'emplacement des étiquettes de sécurité sur la machine. Si, à tout moment, les étiquettes deviennent illisibles, contactez votre représentant autorisé pour un remplacement rapide.

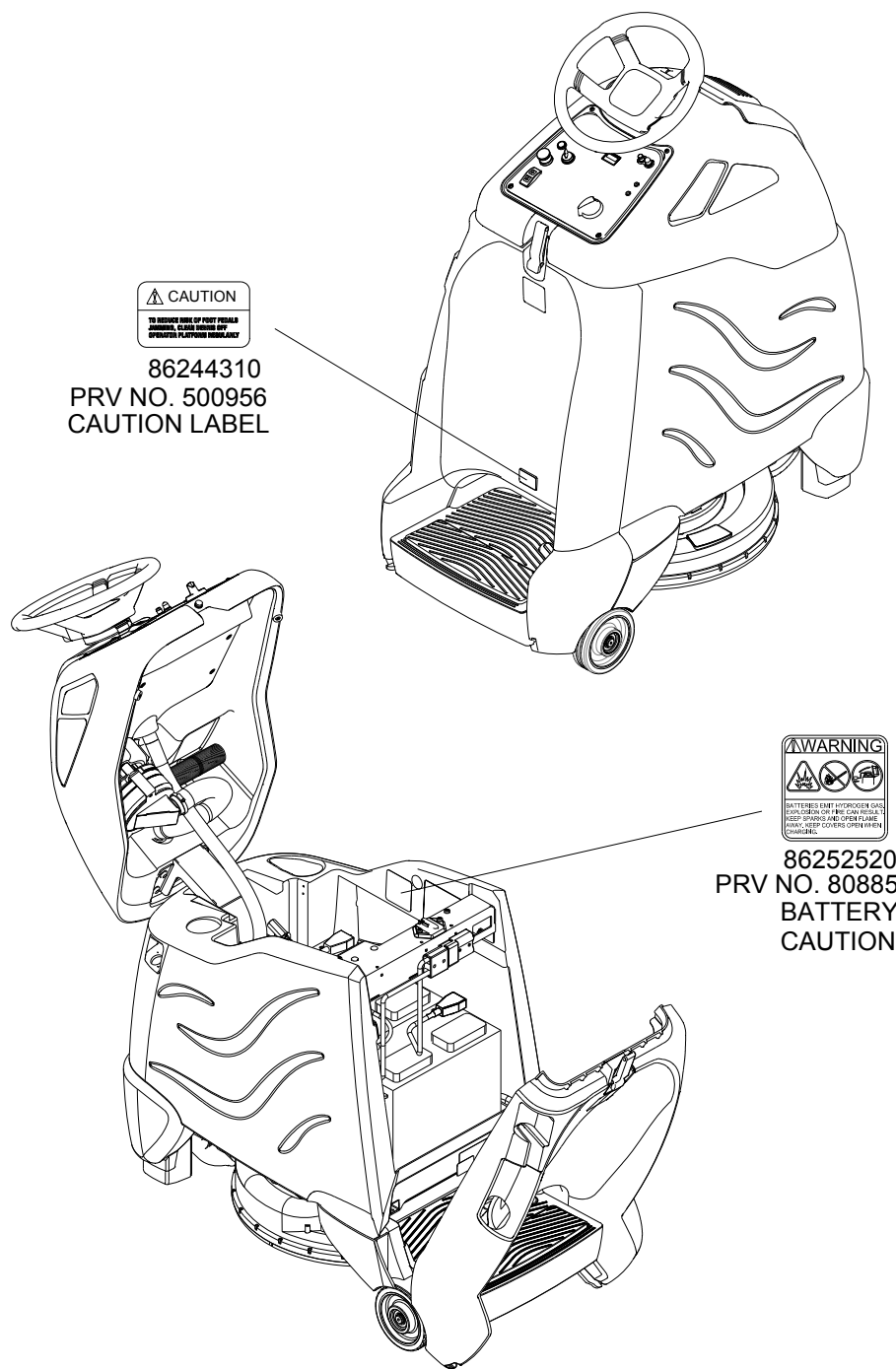

86244310
PRV NO. 500956
CAUTION LABEL



86252520
PRV NO. 80885
BATTERY
CAUTION

Technical Specifications

ITEM	DIMENSION/CAPACITY
Nominal Power	Passive Dust Control 2232W, Active Dust Control 2628W
Rated Voltage	36 Volts DC
Rated Amperage	Passive Dust Control 62A, Active Dust Control 73A
Batteries	3 X12 Volt 114 AH, 130 AH, 225AH, or 234AH @ 20 hr. rate
Battery Compartment Dimensions	21.5 in. x 15.25 in. x 16 in. tall (546mm x 387mm x 406mm tall)
Burnisher Motor	3.0 HP, 36V, 2000RPM (2237W)
Vacuum Motor	.63 HP (470 W)
Maximum flow rate of vacuum motor	72 cfm (33.98 liters per second)
Maximum suction of vacuum motor	47.3 inches of water (11.7 kPa)
Propelling Motor	.21 HP (157 W)
Mass (GVW)	838 lbs (380 kg)
Weight empty without batteries	231 lbs (105 kg)
Burnisher pad diameter	20 inch (508 mm)
Tires	8 in. (203mm) drive, 6 in. (156mm) rear, polyurethane
Maximum Speed	2.7 mph (4.3 Km/hour)
Theoretical Coverage	19,800ft ² /hr @ 2.5 mph with 2 in. overlap
Brake	Electrical parking brake, sets automatically whenever operator stops.
Minimum aisle u-turn width	51in. (1295 mm)
Maximum rated climb and descent angle	10% (6 degrees)
Vibration, hands	1.58 m/s ²
Vibration, feet	1.39 m/s ²
Uncertainty	0.5 m/s ²
Sound pressure level	Passive Dust Control 59.7 dBA, Active Dust Control 62.2 dBA
Sound power level	Passive Dust Control 76.3 dBA, Active Dust Control 80.1 dBA
Uncertainty	3.0 dBA

ITEM	MEASURE
Height	51.8 in (1316mm)
Length	44.0 in (1118mm)
Width	23.4 in. (594mm)
Width of burnish path	20 in (508mm)

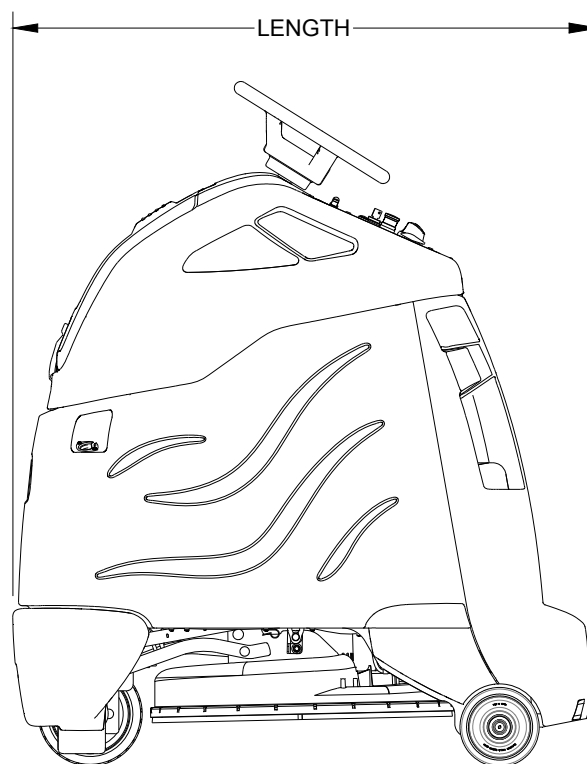
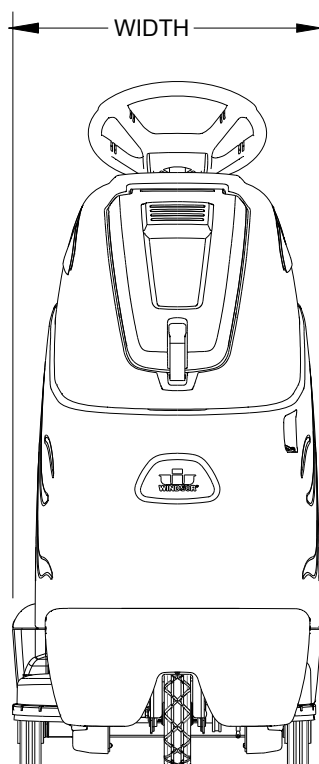

⚠ CAUTION:

This appliance is not intended for use by persons (including children) with reduced physical, sensory or mental capabilities, or lack of experience and knowledge, unless they have been given supervision or instruction concerning use of the appliance by a person responsible for their safety. Children should be supervised to ensure that they do not play with the appliance.

⚠ AVERTISSEMENT:

Cet appareil n'est pas prévu à l'usage des personnes (enfants y compris) avec des possibilités physiques, sensorielles ou mentales réduites, ou le manque d'expérience et de connaissance, à moins qu'ils aient été donnés la surveillance ou l'instruction au sujet de l'utilisation de l'appareil par une personne chargée de leur sûreté. Des enfants devraient être dirigés pour s'assurer qu'ils ne jouent pas avec l'appareil.

How This Machine Works

The Chariot® iGloss 20 is a battery powered, self-propelled, hard floor burnisher intended for commercial use. The appliance spins a high-speed burnishing pad in contact with the floor surface to produce a high luster shine.

The machine's primary systems are the burnishing system, the dust control system, and the operator control system.

The function of the burnishing system is to spin a high-speed burnishing pad in contact with a floor surface that has had a burnishable floor finish applied. The burnishing pad can be lowered to the floor and raised by the operator. The burnishing pad will spin only when the machine is directed to move by the operator.

The function of the dust control system is to collect the dust that is created during the burnishing process. It is normal for a portion of the floor finish to be removed in the form of dust during the process. While burnishing, air movement is created within the burnishing head by the spinning pad. The dust that is also created is entrained in the air stream and transported to a filter bag where it is collected and separated from the air stream. The filter bag can be easily changed without releasing the collected dust. The optional active dust control system uses a vacuum motor to improve dust collection before, during, and after burnishing.

The function of the operator control system is to control the direction and speed of the machine. The directional control system consists of the direction control drive reset switch, throttle pedal, emergency stop/brake switch, steering wheel, propel controller, and drive wheel. The directional control drive reset switch signals forward or reverse direction and makes sure the operator is on the platform before machine will propel. The controller interprets signals from the throttle pedal to command the drive wheel to propel or slow the machine. The steering wheel points the drive wheel in the direction desired by the operator. The parking brake automatically engages when the operator stops the machine. The emergency stop/brake can be used to hold the machine on slopes.

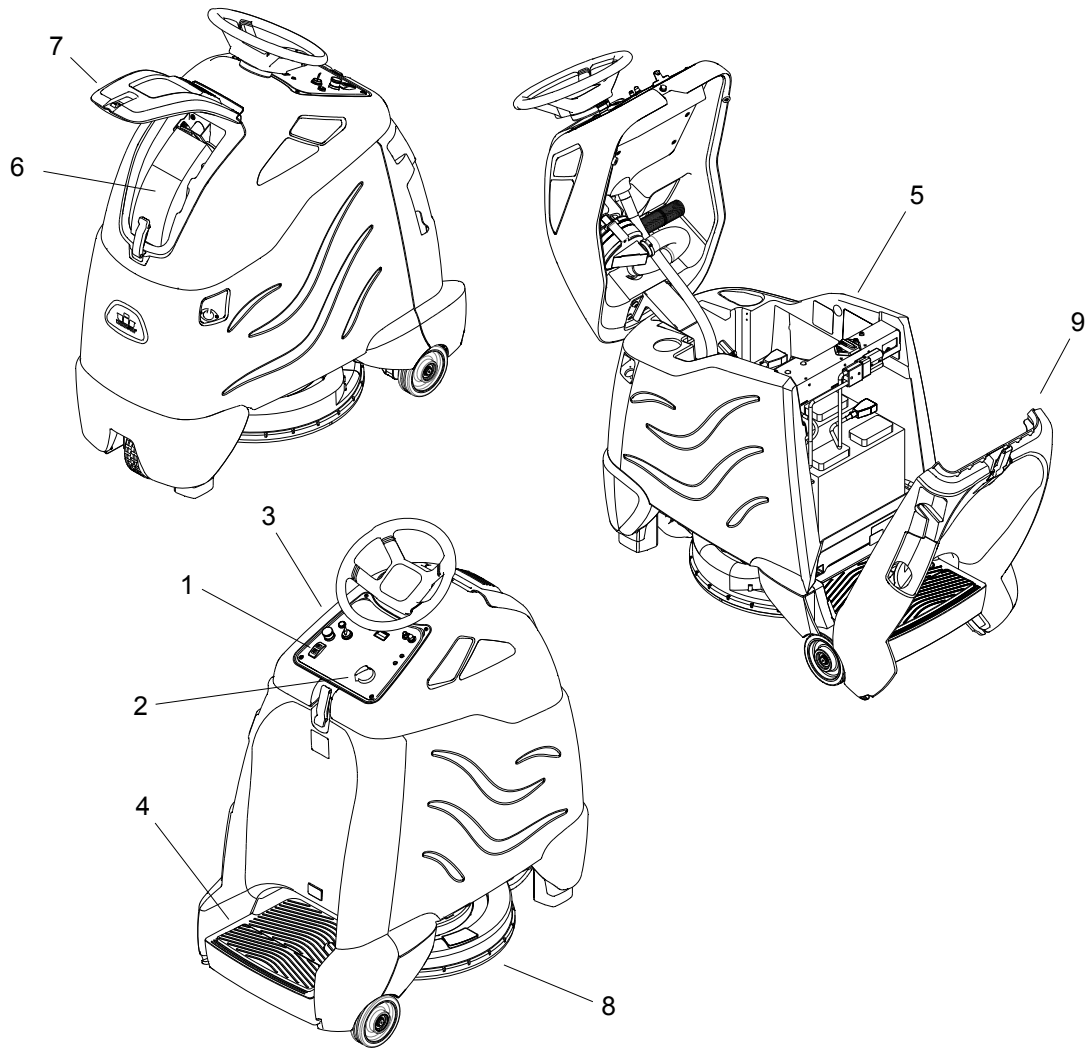

Components

- 1. Drive Control
- 2. Burnisher Controls
- 3. Control Console
- 4. Pedal Platform
- 5. Lower Body
- 6. Bag Enclosure
- 7. Bag Enclosure Cover
- 8. Burnisher Deck
- 9. Rear Cover

Components

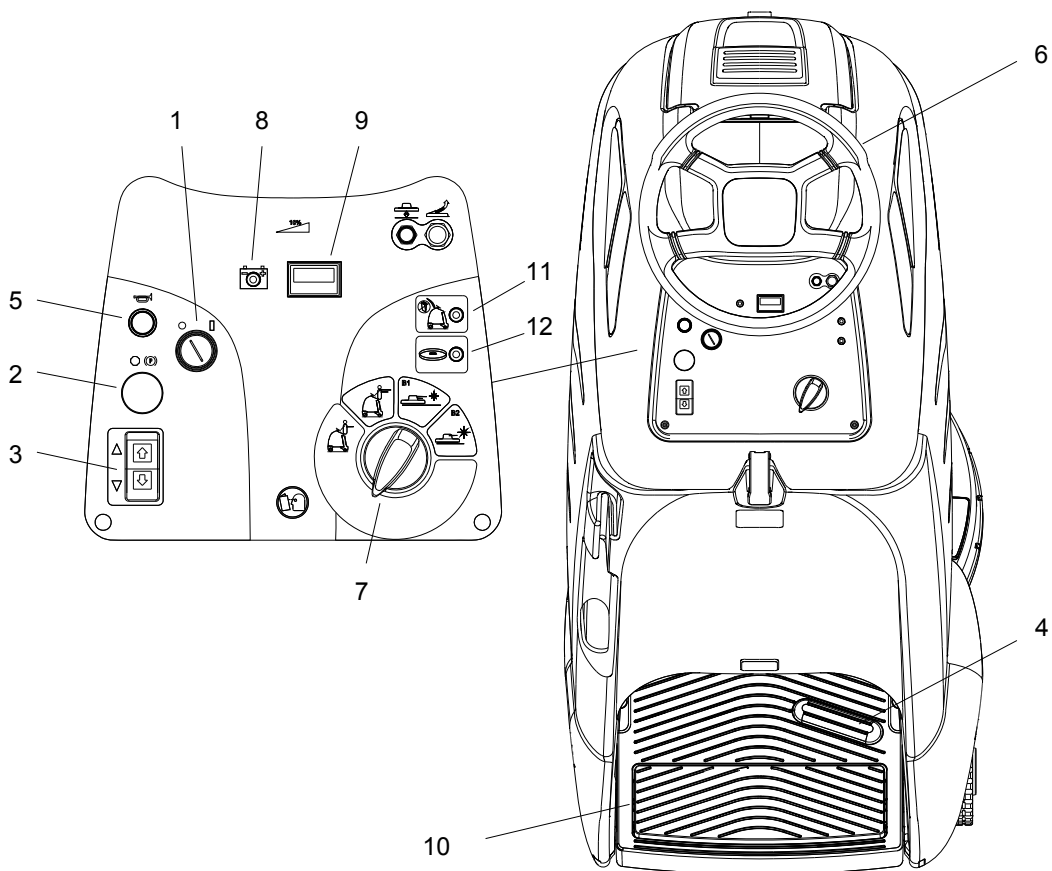

1. Key Switch
2. Emergency Stop/Brake Switch
3. Directional Control / Drive Reset Switch
4. Throttle Pedal
5. Horn Button
6. Steering Wheel
7. Speed Control/Function Select
8. Battery Discharge Indicator
9. Hour Meter
10. Operator Presence Switch
11. Bag Present indicator
12. Check Pad Indicator

1. KEY SWITCH

Controls the power for machine functions.

To turn the machine power on, rotate key clockwise.

To turn the machine off, rotate key counterclockwise.

When the key is turned on the battery symbol will flash once and stay on continuously.

2. EMERGENCY STOP/BRAKE SWITCH

This safety feature is designed to cut all power to the machine at any time and apply parking brake.

To shut the machine power off, push the Emergency Stop Switch, this will also engage the parking brake and cause the machine to stop immediately.

To reset the machine, rotate the switch clockwise.

3. DIRECTIONAL CONTROL / DRIVE RESET SWITCH

This safety feature is designed to ensure safe engagement of propel drive. Each time the machine power is turned on, or each time an operator steps on to the platform, the Drive Reset Switch must be pushed before machine will propel.

The switch controls the direction of travel of the vehicle. The lighted arrow on the switch indicates direction of travel.

To travel forward, press the top of the switch.

To travel in reverse, press the bottom of the switch.

4. THROTTLE PEDAL

Controls the speed of the vehicle within the speed control setting selected. Pressing the pedal causes the machine to travel in the direction selected by the Directional Control Switch.

To increase speed, increase pressure on the pedal.

To decrease speed, decrease pressure on the pedal.

5. HORN BUTTON

The horn is activated by pressing the horn button.

6. STEERING WHEEL

The steering wheel turns the front wheel causing the machine to change direction.

7. SPEED CONTROL

Controls the maximum speed of the machine. There are two settings, slow and fast.

To change speed, rotate the dial to either slow or fast position. The slow position is to the left (counterclockwise), fast to the right (top position).

The throttle pedal will always regulate the speed between 0 and maximum

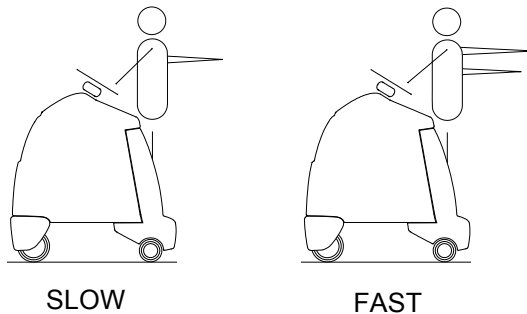

8. BATTERY DISCHARGE INDICATOR

Indicates the charge level of the batteries.

The indicator will be illuminated if the batteries have a sufficient charge. A slow, continuous flash indicates the batteries require charging.

The Battery Lockout function will activate when the batteries are low.

Once active, the LED status indicator will begin to flash slowly and the controller will inhibit the burnisher motor.

The vacuum and drive remain functional. Return the unit to the charging station and charge the batteries.

NOTES: Continuing usage may damage the batteries.

When the machine is left overnight with less than a full charge, the display may initially indicate a full charge. It will also indicate a full charge if the batteries are disconnected, then reconnected. After a few minutes of operation the indicator will give the correct charge level.

9. HOUR METER

Records the number of hours the machine has been in burnishing operation. This information is useful in determining when to service the machine.

10. OPERATOR PRESENCE SWITCH

Must be pressed down prior to any machine functions enabled.

11. BAG PRESENT INDICATOR

Notifies operator if dust collection bag is missing. LED is red when bag is missing or not properly installed.

12. CHECK PAD INDICATOR

Notifies operator of potential problem with pad or missing pad. When LED is red, operator should remove pad driver and verify pad condition and proper installation.

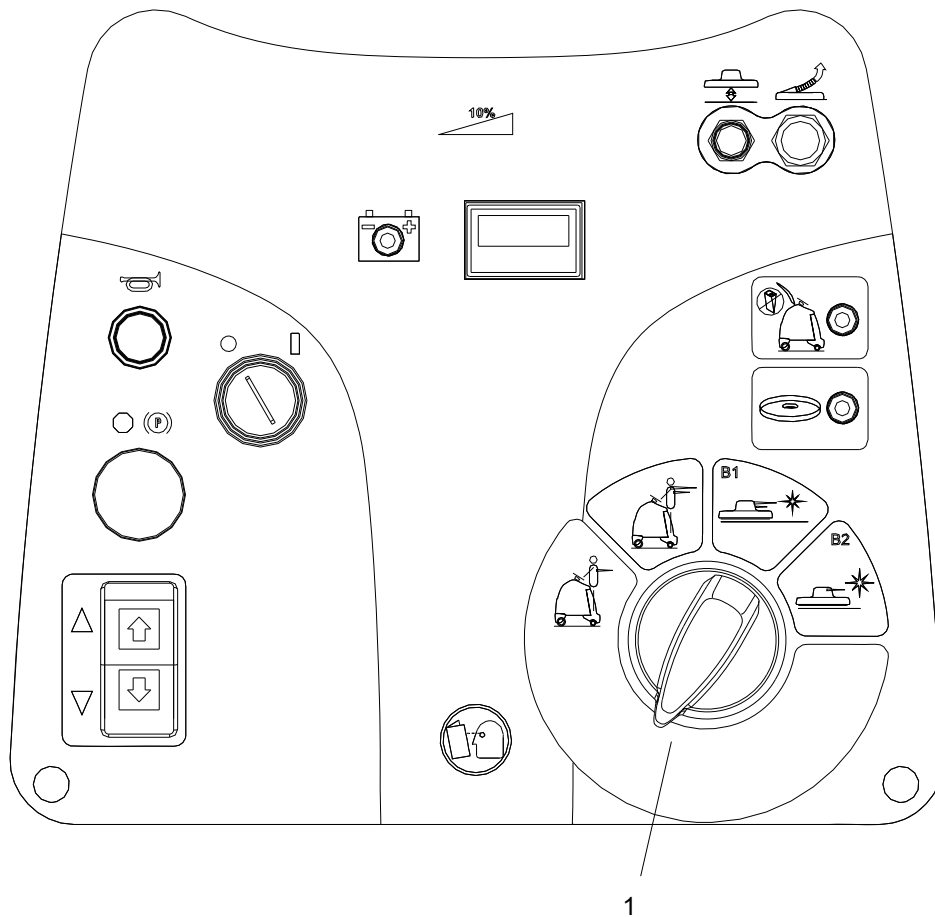

1. FUNCTION MODE SWITCH

The first two positions are for transport only. See drive controls section.

B1 - Light burnishing

This mode is used for light burnishing. In this mode the machine will propel at fast speed. The 'floating' burnisher deck is in the down position. When equipped with optional active dust collection, vacuum motor will be on.

B2 - Deep burnishing

This mode is used for deep burnishing. In this mode the machine will propel at slow speed. The 'floating' burnisher deck is in the down position. When equipped with optional active dust collection, vacuum motor will be on.

Machine Operation

Pre-Run Machine Inspection

Do a pre-run inspection to find possible problems that could cause poor performance or lost time from break-down. Follow the same procedure each time to avoid missing steps.

NOTE: See maintenance section for pre-run machine inspection checklist items.

Starting Machine

NOTE: Perform pre-run machine check before operating machine.

FOR SAFETY: Before starting machine, make sure that all safety devices are in place and operating properly.

1. Disconnect or unplug battery charger.
2. Close the cover(s).
3. Verify condition of burnishing pad, replace if necessary.
4. Verify removable pad driver is installed correctly and pad rotation lock is released.
5. The operator should be on the pedal platform. The throttle pedal must be in the neutral position.
6. Turn the machine power on by turning key switch clockwise to the "ON" position.
7. Verify dust collection bag is installed.
8. Press the Drive Reset Directional Control Switch to reset and set the intended direction for travel.
9. Press lightly on the throttle pedal with right foot

Emergency Stop Procedure

Push in emergency stop button. This will also engage the parking brake and cause the machine to stop immediately.

Operating the Machine

When operating the machine around people, pay close attention for unexpected movement. Use extra caution around children.

1. Stand on the operator platform. Throttle pedal must be in neutral position.
2. Turn machine power on.
3. Select transport speed from Function Mode Switch.
4. Press the Drive Reset/Directional Control Switch, selecting the desired travel direction.
5. Select B1 or B2 from the Function Mode Switch. Deck will Lower.
6. The pad motor will only run when the burnishing head is lowered to within 2 inches of the floor.
7. Occasionally verify "check pad" indicator light is "green". If not, stop machine, remove pad driver and check pad. Replace or flip as needed.

NOTE: To prevent possible damage to the floor surface, always keep the machine moving while the pad is spinning.

8. When the head is down and the machine is propelled, the pad motor runs.
9. When the battery light flashes it indicates discharged batteries, stop operation and charge batteries.

Normal Burnishing

Plan the burnishing pattern in advance. The longest track is around the perimeter of the area to be burnished. For efficient operation, the runs should be the longest possible without turning, stopping, or raising or lowering the burnisher head.

In order to achieve the best possible results, the area which is to be burnished should be swept and auto scrubbed before burnishing.

INEFFICIENT BURNISHING PATH

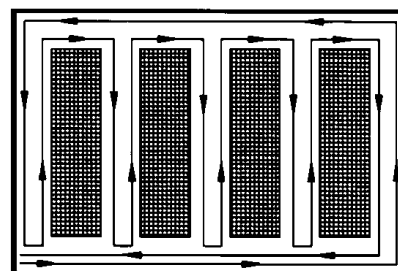

RECOMMENDED BURNISHING PATH

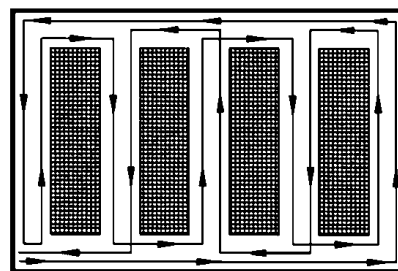

Service Schedule

MAINTENANCE	BEFORE EACH WORK PERIOD	AFTER EACH WORK PERIOD	50 HRS	100 HRS	200 HRS
Check water level of batteries after charging; add distilled water if necessary. (Wet cell only)	*				
Visually check for damaged or worn tires.	*				
Check brush or pad for proper installation.	*				
Check vacuum hose connections.	*				
Check pedal, brake and steering for proper operation.	*				
Check dust bag.		*			
Charge batteries if needed.		*			
Clean off top of batteries.			*		
Check battery cells with hydrometer. (Wet cell only)			*		
Inspect deck skirt.			*		
Check battery connections are tight.			*		
Clean battery cases and battery compartment.				*	
Check parking brake.					*
Clean pivot points on burnishing head.					*
Check all motors for carbon brush wear.					*
Check steering chain tension.					*
Check drive chain tension.					*

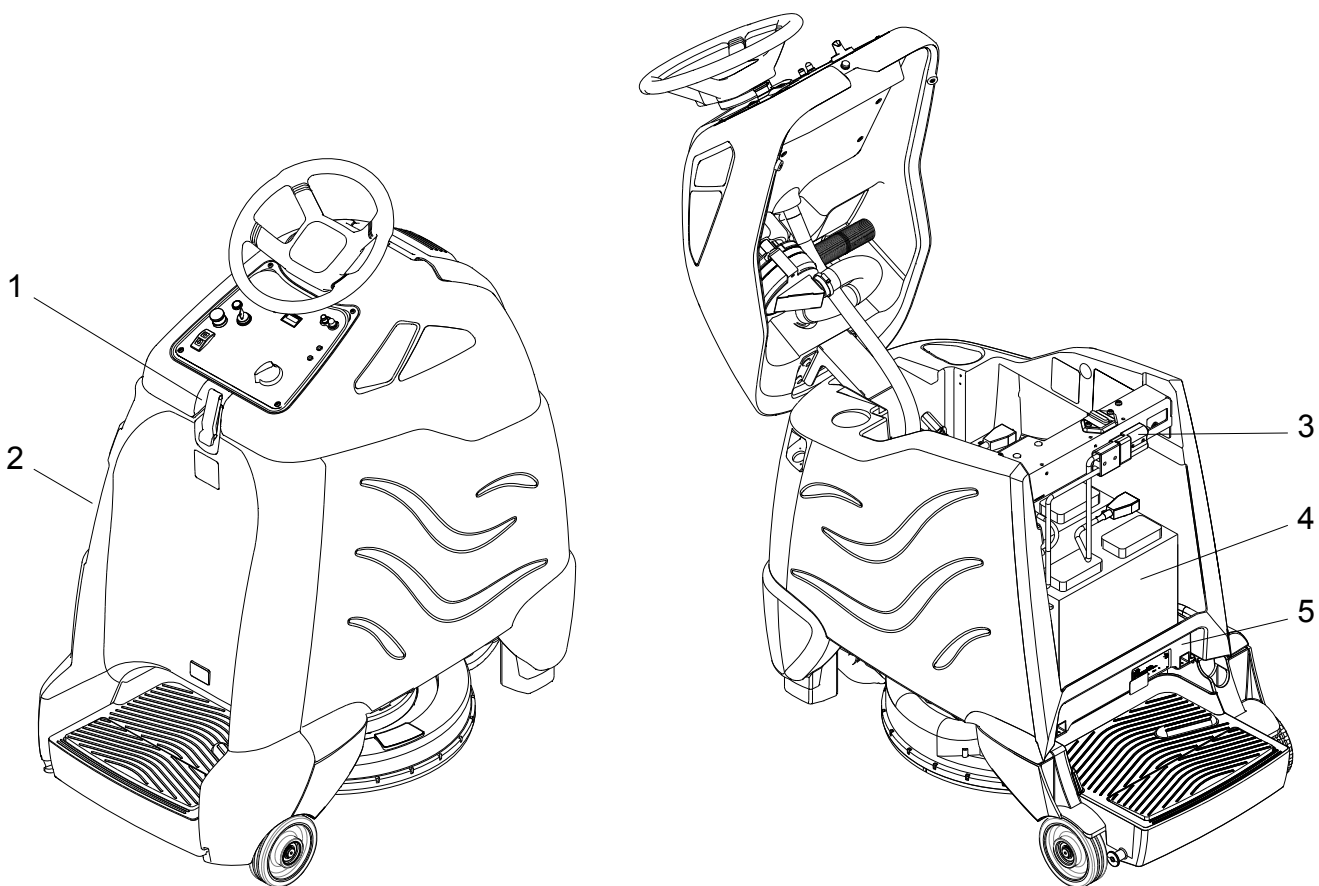

- 1. Cover Retainer Latch
- 2. Rear Cover
- 3. Battery Connector-Machine
- 4. Batteries
- 5. Battery Tray

Batteries (Wet Cell)

The batteries provide the power to operate the machine. The batteries require regular maintenance to keep them operating at peak efficiency.

The machine batteries will hold their charge for long periods of time, but they can only be charged a certain number of times. To get the greatest life from the batteries, charge them when their charge level reaches 25% of a full charge. Use a hydrometer to check the charge level.

Do not allow the batteries to remain in a discharged condition for any length of time. Never expose a discharged battery to temperatures below freezing. Discharged batteries will freeze causing cracked cases. Do not operate the machine if the batteries are in poor condition or if they have a charge level below 25% (specific gravity below 1.155).

Keep all metallic objects off the top of the batteries, as they may cause a short circuit. Replace worn or damaged cables and terminals.

Check the electrolyte level in each battery cell before and after charging the batteries. Never add acid to the batteries, use distilled water. Do not allow water level to fall below the battery plates. Portions of plates exposed to air will be destroyed. Do not overfill. Keep plugs firmly in place at all times.

WARNING:

Not all batteries require maintenance. AGM batteries are maintenance free. Do not attempt to remove sealed caps from AGM batteries. Warranty is void if caps are removed from AGM battery.

AVERTISSEMENT:

L'entretien n'est pas nécessaire pour toutes les batteries. Les batteries AGM ne nécessitent pas d'entretien. N'essayez pas d'enlever les bouchons scellés des batteries AGM. La garantie est annulée si les bouchons sont retirés des batteries AGM.

⚠ CAUTION:

When servicing machine, avoid contact with battery acid.

⚠ ATTENTION:

Lors de l'entretien de la machine, évitez tout contact avec l'acide de batterie.

⚠ WARNING:

Batteries emit hydrogen gas. Explosion or fire can result. Keep sparks and open flame away. Keep covers open when charging.

⚠ AVERTISSEMENT:

Les batteries émettent du gaz hydrogène. Une explosion ou un incendie peut en résulter. Maintenez les étincelles et les flammes nues à l'écart. Gardez les carters ouverts lors du chargement.

⚠ WARNING:

Wear eye protection and protective clothing when working with batteries.

⚠ AVERTISSEMENT:

Portez des lunettes de protection et des vêtements de protection lorsque vous travaillez avec des batteries.

⚠ WARNING:

Charge batteries in a well ventilated area.

⚠ AVERTISSEMENT:

Chargez les batteries dans un endroit bien ventilé

Battery Maintenance

1. When cleaning the batteries, use a solution of baking soda and water. Do not allow the cleaning fluid to enter the battery cells, electrolyte will be neutralized.
2. Maintain the proper electrolyte level in each battery cell. If a cell should accidentally overflow, clean immediately.
3. Wipe off the top of the batteries at least once a week.
4. Test battery condition with a hydrometer at least once a week.
5. Ensure that all connections are tight and all corrosion removed.
6. Every 4 to 6 months, remove the batteries from the machine and clean the battery cases and battery compartment.

Checking Battery Specific Gravity

Use a hydrometer to check the battery specific gravity.

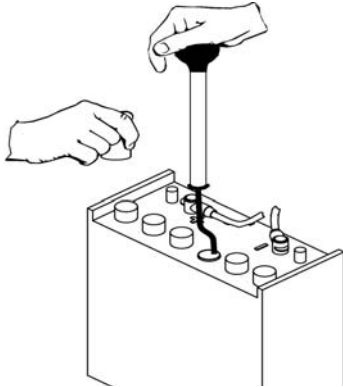

CHECKING GRAVITY

- a. Hydrometer Battery
- b. Battery

NOTE: Do not take readings immediately after adding distilled water, if the water and acid are not thoroughly mixed, the reading may not be accurate.

Check the hydrometer readings against this chart.

SPECIFIC GRAVITY @ 80° F (27°C)	BATTERY CONDITION
1.265	100% CHARGED
1.225	75% CHARGED
1.190	50% CHARGED
1.155	25% CHARGED
1.120	DISCHARGED

NOTE: If the readings are taken when the battery electrolyte is any temperature other than 80°F (27°C), the reading must be temperature corrected.

To find the corrected specific gravity reading when the temperature of the battery electrolyte is other than 80°F (27°C): Add (+) to the specific gravity reading 0.004 (4 points), for each 10°F (6°C) above 80° (27°C). Subtract (-) from the specific reading 0.004 (4 points), for each 10°F (6°C) below 80°F (27°C).

Charging Batteries

⚠ CAUTION:

When servicing machine, avoid contact with battery acid.

⚠ ATTENTION:

Lors de l'entretien de la machine, évitez tout contact avec l'acide de batterie.

⚠ WARNING:

Batteries emit hydrogen gas. Explosion or fire can result. Keep sparks and open flame away. Keep covers open when charging.

⚠ AVERTISSEMENT:

Les batteries émettent du gaz hydrogène. Une explosion ou un incendie peut en résulter. Maintenez les étincelles et les flammes nues à l'écart. Gardez les carters ouverts lors du chargement.

⚠ WARNING:

Wear eye protection and protective clothing when working with batteries.

⚠ AVERTISSEMENT:

Portez des lunettes de protection et des vêtements de protection lorsque vous travaillez avec des batteries.

⚠ WARNING:

Charge batteries in a well ventilated area.

⚠ AVERTISSEMENT:

Chargez les batteries dans un endroit bien ventilé

Use a 36 volt, 20 amp maximum output DC charger which will automatically shut off when the batteries are fully charged.

1. Stop the machine in a clean, well ventilated area next to the charger.
2. Turn "OFF" machine.

FOR SAFETY: Before leaving or servicing machine; stop on level surface, turn off machine and remove key.

3. Remove rear cover, unplug batteries from machine.

⚠ WARNING:

Batteries emit hydrogen gas. Explosion or fire can result. Keep sparks and open flame away. Keep covers open when charging.

⚠ AVERTISSEMENT:

Les batteries émettent du gaz hydrogène. Une explosion ou un incendie peut en résulter. Maintenez les étincelles et les flammes nues à l'écart. Gardez les carters ouverts lors du chargement.

4. Check the electrolyte level in each battery cell. Before charging, add just enough distilled water to cover the plates. After charging is complete, add just enough distilled water to bring up the level to the indicator ring. If the water level is too high before charging, normal expansion rate of the electrolyte may cause an overflow resulting in a loss of battery acid balance and damage the machine.

5. Replace the battery caps, and leave them in place while charging.
6. Unplug the battery connector from the machine.

FOR SAFETY: When charging, connect the charger to the batteries before connecting the charger to the AC wall outlet. Never connect the charger to the AC wall outlet first. Hazardous sparks may result.

7. Plug the charger connector into the battery connector. Connect the charger AC plug to a wall outlet. The charger gauge should indicate that the batteries are charging.
8. When the batteries are fully charged, disconnect the charger from the AC wall outlet, then disconnect the charger from the batteries.
9. Connect the batteries to the machine connector.
10. Check the electrolyte level. It should be up to the indicator ring. If necessary, add distilled water.
11. Install the rear cover.

Changing Batteries

Stop the machine in a clean area next to the charger. Turn off machine.

FOR SAFETY: Before leaving or servicing the machine; stop on level surface, turn off machine and remove key.

1. Open the console cover.
2. Remove rear cover.
3. Disconnect battery pack from machine.

Use the proper size open end wrench to disconnect main ground wire first and secure cable terminal away from batteries.

4. Disconnect main positive lead and secure cable terminals away from batteries.
5. Loosen both terminals on each jumper cable and remove one at a time.
6. Prepare a suitable site to place the batteries.

⚠ WARNING:

Attach suitable battery lifting device and lift batteries from the machine. Batteries are a potential environmental hazard. Consult your battery supplier for safe disposal methods.

⚠ AVERTISSEMENT:

Fixez le dispositif de levage de batterie approprié et levez les batteries de la machine. Les batteries constituent un danger potentiel pour l'environnement. Consultez le fournisseur de votre batterie pour c

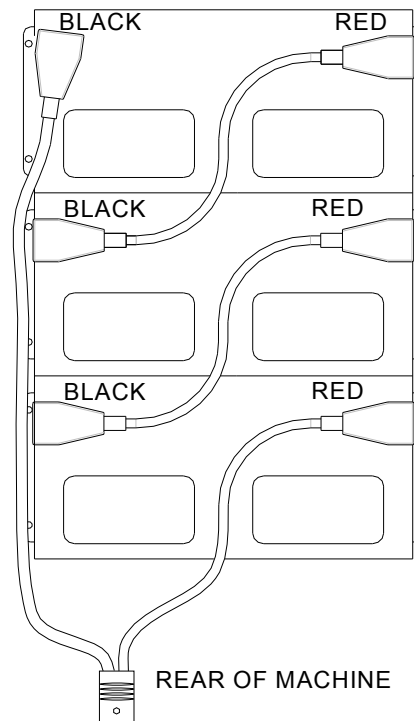

NOTE: Red (+) and Black (-) installed opposite for 225 AH (J185) battery configuration.

Battery Charger Programming

NOTE: For machines equipped with optional on-board charger. When replacing batteries, charger programming changes may be required. If replacing batteries with same type, (e.g. maintenance free batteries with maintenance free) no programming is required. When batteries with different type (e.g. maintenance free with wet cell), programming changes are required. Failure to make programming changes may lead to reduced battery life.

Programming Instructions

The charger is pre-loaded with the charge algorithms shown below:

AlgID	Description
1	Trojan J185H
5	Trojan 30XHS
42	Discover AGM EV31A-A
43	Discover AGM EV185A-A

Check Default Charge Algorithm

Enter Algorithm Display Mode:

1. Disconnect AC Power.
2. Remove positive lead from battery pack.
3. Apply AC power and the charger will display the algorithm number after the Power On Self Test:
 - a. All algorithms will display as a series of flashes of the 80% LED.
 - b. Algorithms #1 - 6 will also be indicated by the Ammeter LEDs (see Users Guide).

Examples:

☼☼☼☼ = Algorithm #3

☼☼☼ , Short Pause, ☼ = Algorithm #21

4. Algorithm number display repeats for 11 seconds, then Algorithm Display Mode ends.
5. Remove AC Power and reconnect positive lead.

Check Default Charge Algorithm

1. Enter Algorithm Display Mode (as above).
2. While Algorithm Number is displayed (for 11 seconds), touch positive lead to the battery pack positive terminal for 3.0 seconds ($\pm 0.5s$).
3. Remove lead from battery pack. Algorithm Number will increment.
4. To increment the Algorithm Number again, repeat Steps 2 and 3 within 30 seconds.
5. Touch positive lead to positive terminal and hold until relay clicks (>10 seconds). The new default algorithm is now stored.
6. Remove AC power and check default algorithm.

Contact your original equipment manufacturer if your battery pack is not supported by the charge algorithms loaded in your charger.

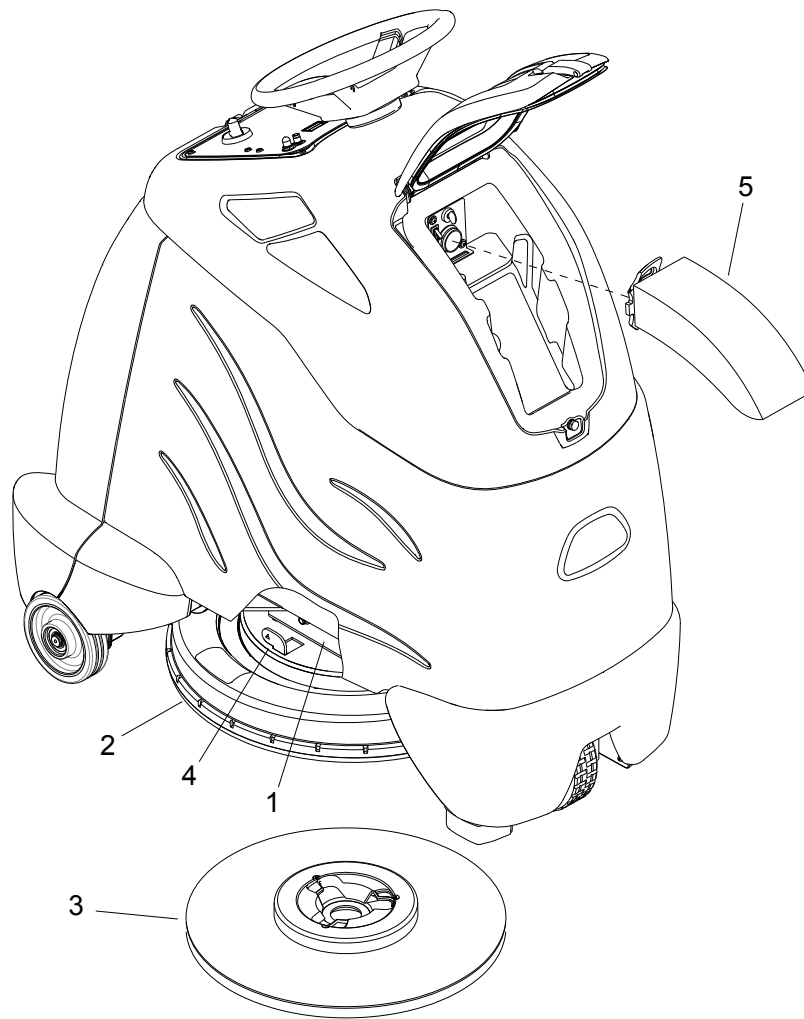

Burnishing Deck

- 1. Burnisher Motor
- 2. Skirt
- 3. Pad Driver/Pad
- 4. Pad Rotation Lock Lever

Dust Collection

- 5. Dust Bag

Burnishing Pad

Many types of pads are available for floor burnishing. Select a pad type based on floor type and floor finish for best results.

Dust Bag Replacement

1. Release latch and raise cover to access dust bag.
2. Turn thumb screw to horizontal position to release dust bag.
3. Remove dust bag at the plastic frame from the bag mounting bracket.
4. Reverse procedure to install new bag.

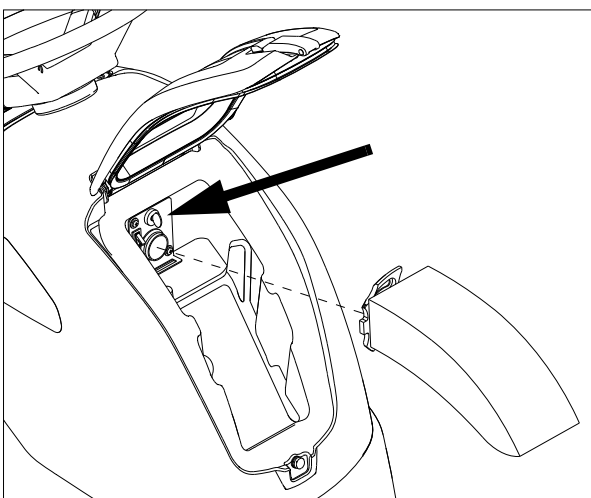

Dust Control Skirt Replacement

1. Raise burnisher deck with Function Mode Switch set to transport mode.
2. Find ends of brush skirt. Pull down on one end to release from shroud snap features. Once released from two snaps, gently pull skirt parallel to the floor to fully remove from shroud.
3. Install new skirt by pushing up into snaps one at a time working around shroud diameter.
4. Where the ends meet, trim any excess skirt with scissors or wire cutter.

Pad Replacement

1. Set the burnisher deck to the raised position.
2. To remove the pad driver:
 - Push in and hold the Pad Rotation Lock lever.
 - Grip the outside diameter of the pad and pad driver.

- Rotate firmly counterclockwise. Pad driver will disconnect from motor hub.
- Release Pad Rotation Lock lever.

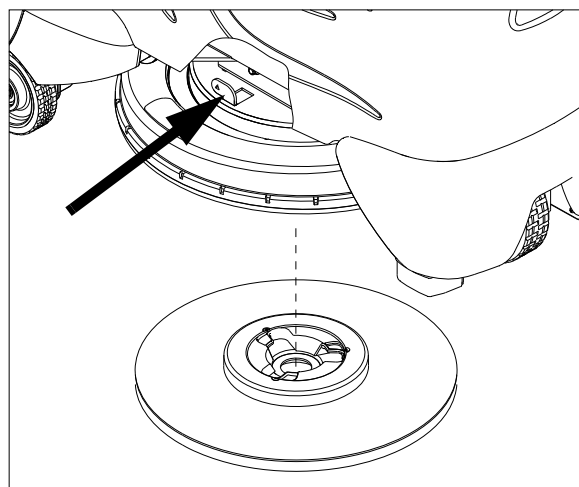

3. To remove pad from pad driver:
 - Set pad driver on flat surface with pad facing up.
 - Release pad retainer from center of pad using retainer's wire clip.
 - Peel pad off pad driver.
4. To install pad on pad driver:
 - Center the pad on pad driver with pad facing up.
 - Check the pad inner diameter where the pad fits over the raised ring of the pad retainer.
 - Install pad retainer making sure wire clips snap in place. Pad will need to compress to engage pad retainer clips
5. To install the pad driver:
 - Push in and hold the Pad Rotation Lock lever.
 - Hold the pad driver parallel to the floor under the shroud.
 - Lift pad driver up to contact hub keeping level and centered with motor shaft.
 - Rotate pad driver clockwise applying light pressure up on the hub. Pad driver will align with hub and move up.
 - Continue rotating clockwise approximately 15 degrees to fully engage hub.
 - Release Pad Rotation Lock lever.

NOTE: Final tensioning of the pad driver occurs as the motor rotates during burnishing.

Burnisher Motor Replacement

1. Remove the pad driver assembly.
2. Lower the burnisher deck using the Function Mode Switch.
3. Turn the key to the off position.
4. Unplug the battery pack from the machine.
5. Disconnect the positive and negative wires from the posts at the front of the motor. Note the positions for reassembly. Isolate the ends of the wires as batteries will be connected in step 6.
6. Unhook deck lift springs, one per side. Prevent bracket from retracting inside body of machine by using holes and temporary cross pin.
7. Remove the hardware (4X) connecting the linkage to the motor mount. Note the stack arrangement of the hardware for reassembly.
8. Plug in the battery pack. Turn on the key. Turn the Function Mode Switch to transport to raise upper linkage.
9. Slide the deck assembly from under the machine.
10. Flip the deck assembly over.
11. Slide Pad Rotation Lock lever in and hold while removing bolt and washer from pad driver hub.
12. Release Pad Rotation Lock lever slide hub and key off motor shaft.
13. Remove bolts and washers (4X) holding inner shroud and plate. Remove motor from shrouds and motor mount.
14. Reverse process to reinstall.

Burnisher Motor Carbon Brush Ring Replacement

1. Follow steps 1-9 of "Burnisher Motor Replacement" to access the top of the motor.
2. Remove flat head screws (4X) in the motor cover. Remove the cover.
3. Remove hex head screws (4X) holding the brush ring assembly to the motor casting.
4. Slide the brush ring assembly off the motor commutator.
5. Clean excessive carbon deposits off motor components with compressed air.

6. Prepare new brush assembly for use by inserting individual brush springs into brush guides. Check each brush to ensure proper movement after installing springs.
7. Depress brushes as required to insert brush housing over commutator.
8. Check area under cable lugs to make sure brush ring is seated against casting fully.
9. Replace hex head screws (4X) holding the brush ring assembly.
10. Rotate motor to check for smooth rotation.
11. Replace motor cover and flat head screws (4X).
12. Reverse steps in step 1 to reinstall to machine.

Deck Actuator Removal / Replacement

FOR SAFETY: Before leaving or servicing machine, stop on a level surface. Turn off machine.

1. Support deck under pad driver so that actuator pins can be removed.
2. Remove bumper screws (2).
3. Remove front battery.
4. Pull steering shaft.
5. Disconnect actuator from wiring harness.
6. From the underside of the machine, remove lower lifting pin from actuator.
7. Remove clevis pin from actuator upper bracket.
8. Lift actuator upward and free from machine.
9. Reverse steps to install.

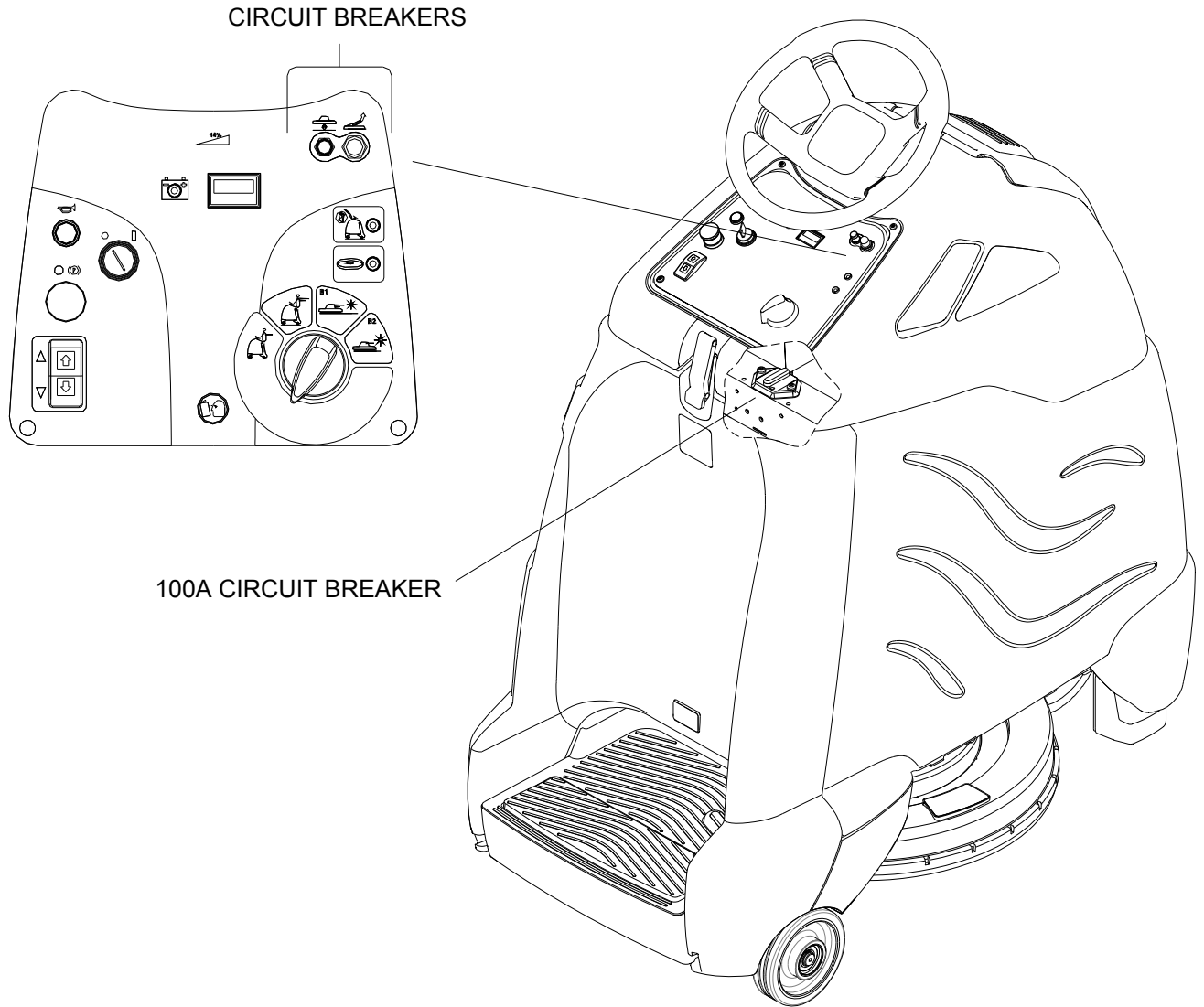

Circuit Breakers

Circuit breakers interrupt the flow of power in the event of an electrical overload. When a circuit breaker is tripped, reset it by pressing the exposed button. If a circuit breaker continues to trip, the cause of the electrical overload should be found and corrected.



1.5 Amp protects the deck lift actuator, horn & controller.



18 Amp protects the vacuum motor.

100 Amp protects the burnisher motor.

Vacuum - Optional

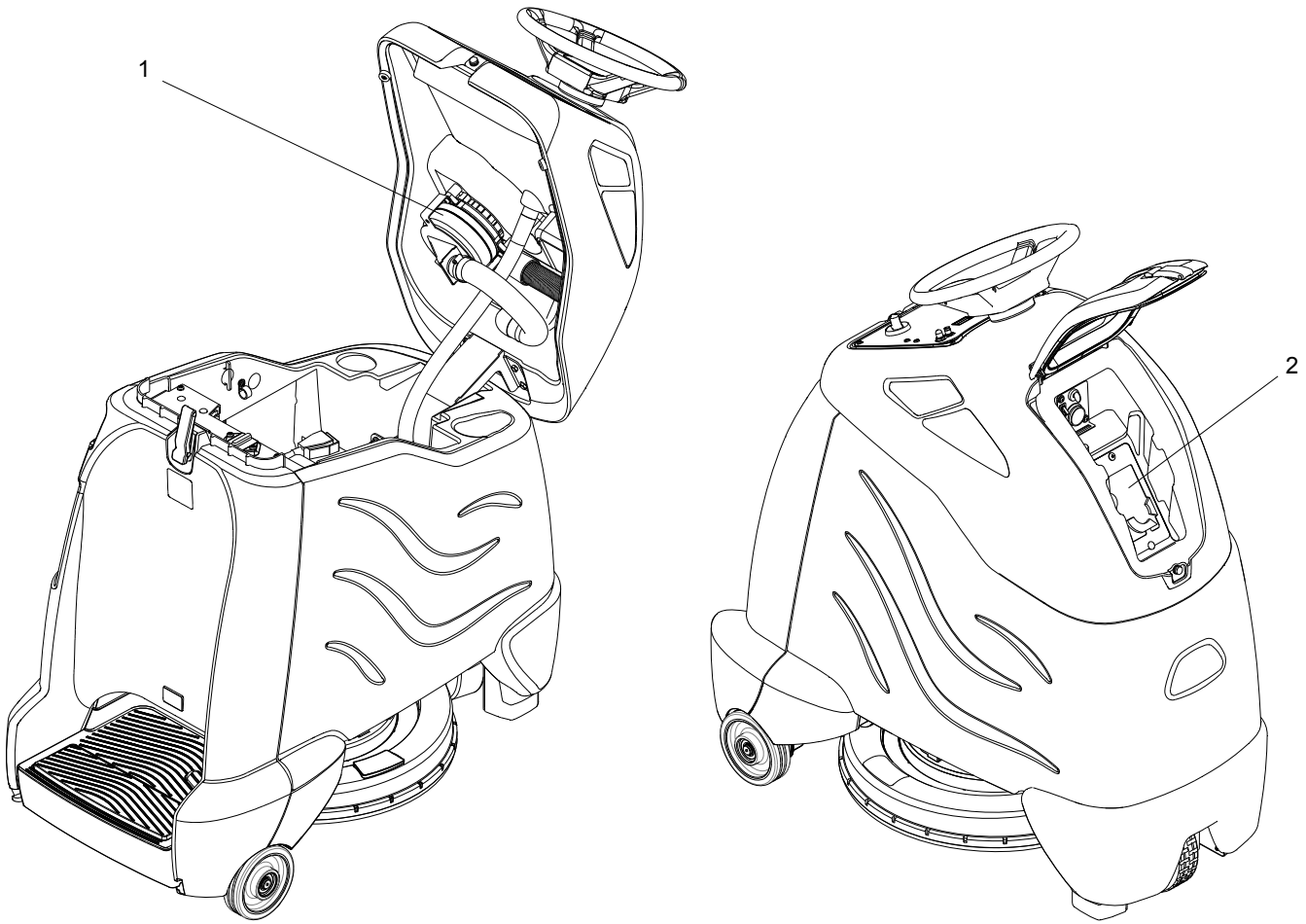

1. Vacuum Motor

2. Vacuum Filter

To Replace Vacuum Filter

1. Open dust bag cover.
2. Remove dust bag.
3. Unlock bottom of filter frame by bending it slightly and slide from under the bolt head.
4. Lift filter out of housing.
5. Reverse steps to install.

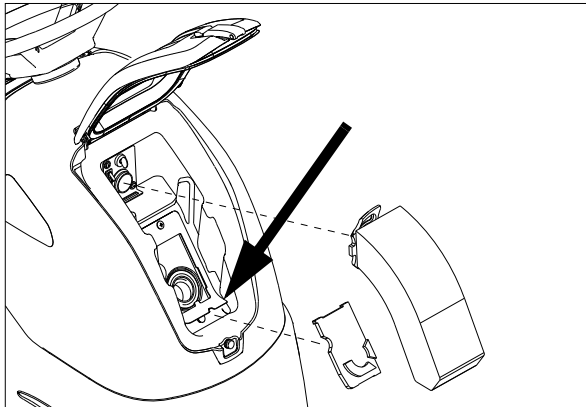

Vacuum Motor Carbon Brush Replacement

FOR SAFETY: before leaving or servicing machine, stop on a level surface, turn off machine and disconnect power.

Vacuum Motor Carbon Brushes

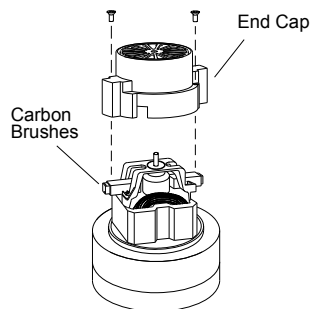

If armature commutator is grooved, extremely pitted or not concentric, the motor will need to be replaced or sent to a qualified service center.

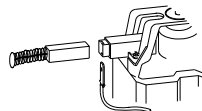

Important:

These brushes wear quicker as the length shortens due to increased heat. Spring inside brush housing will damage motor if brushes are allowed to wear away completely.

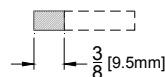

Periodically check the length of the carbon brushes. Replace both carbon brushes when either is less than 3/8" (9.5mm) long.

To Repair or Replace Vacuum Motor

1. Remove four (4) screws from top of control panel.
2. Tip control panel back from console to expose vacuum motor wires.
3. Disconnect electrical connector from the vacuum motor.
4. Replace control panel, attach with one (1) screw to secure in place.
5. Open console.
6. Remove three (3) screws and mounting bracket that secure vacuum motor.
7. Reverse steps to install.

MOUNT .80" FROM SEALING SURFACE OF CONSOLE TO THE TOP OF THE MOUNTING TABS (3).

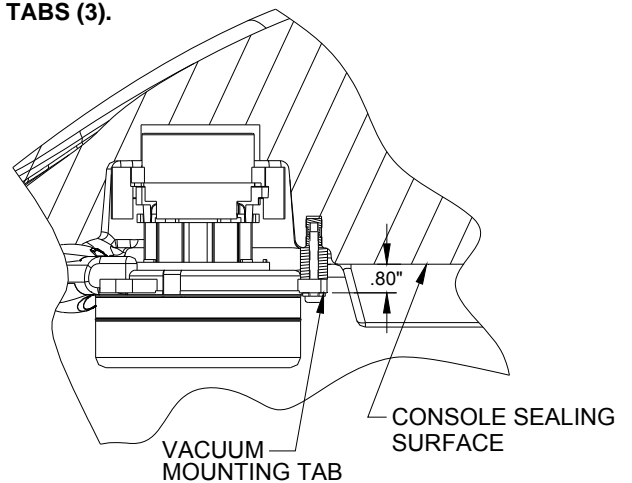

NOTE: If vacuum motor is not mounted as shown, vacuum may not seal properly, resulting in poor performance.

Body Assembly Removal

In order to access the frame or drive components, the entire tank/console cover assembly can be removed as a single unit.

Body Removal:

1. Open the console cover.
2. Remove back panel.
3. Grasp the lower end of the flexible steering shaft and pull it straight up until it is disengaged with the hex steering shaft.
4. Disconnect the five electrical plugs located just forward of the battery tray. Access plugs through front left hole in main body.
5. Remove the battery cable connection from the rear cross member.
6. Close the console cover.
7. Remove the bumper. One mounting bolt per side is located just above the tip pads on the inside.
8. Remove 6 bolts holding the body in place.
9. The body assembly can now be lifted off the chassis and set aside.
10. Reverse the process for reassembly.

Drive Unit Removal

1. Remove tank assembly.
2. Pull the brake and drive electrical connectors off of their support plate.
3. Remove the P-clamp holding the cable.
4. Lift the chain cover plate off of the motor.
5. Support the chassis on the tip pads so that the front wheel is 10 inches off the floor.
6. Locate and remove two mounting nuts and remove the drive unit from below.
7. To reinstall, reverse the process.

NOTE: The small tab at the front of the drive unit frame should line-up with the notch in the mating plate.

Drive Motor

Drive Motor Carbon Brush Replacement

⚠ WARNING:

Do not use a pressure washer to clean around the motors. Use tap pressure only.

⚠ AVERTISSEMENT:

N'utilisez pas de nettoyeur haute pression pour nettoyer autour des moteurs des brosses. Utilisez seulement la pression du robinet.

FOR SAFETY: Before leaving or servicing machine, stop on a level surface, turn off machine and remove motor carbon brushes.

1. Open the console cover.
2. Tilt the recovery tank back until it stops on the lanyard.
3. Grasp the lower end of the flexible steering shaft and pull it straight up until it is disengaged with the hex steering shaft. Place the loose end into one of the fill ports.
4. Remove the cover and gasket at the steering shaft area.
5. Grasp the drive wheel by reaching under the front bumper and turn it to near the left steering stop.
6. The drive motor carbon brushes are located under screw caps. The caps are accessible by gently moving the harness aside.
7. Rotate the drive wheel to near the right hand stop to access the right side carbon brush.
8. Replace the gasket and cover, set the drive wheel straight ahead, set the steering wheel straight ahead, and gently align the steering shaft coupling and slide onto the lower shaft.
9. Slowly close the cover and make sure the shaft slides without binding.

Drive Chain Tension

The drive chain should deflect about 1/4 inch on either side of the loop when the opposite side is tight.

To adjust chain tension:

1. Remove bumper.
2. Loosen five (5) 10mm screws that hold the drive gear motor and slide the gear motor up until the chain tension is correct. Retighten the five (5) mounting bolts.
3. Reinstall the bumper.

Pushing Machine

This machine is equipped with a drive gear engagement/disengagement lever.

The brake automatically engages and keeps the machine from moving whenever the operator stops the machine.

The drive gear can be disengaged so the machine can be pushed or towed (slowly).

When the drive gear is disengaged the machine cannot be driven.

NOTE: Front bumper removed for clarity and to show access to lever.

Lever access

Turn wheel to left and reach up under bumper and steel bracket.

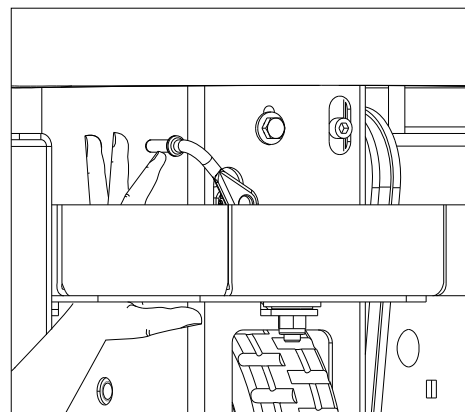

Drive gear engaged

Machine can be driven.

Rotate lever firmly in direction of arrow.

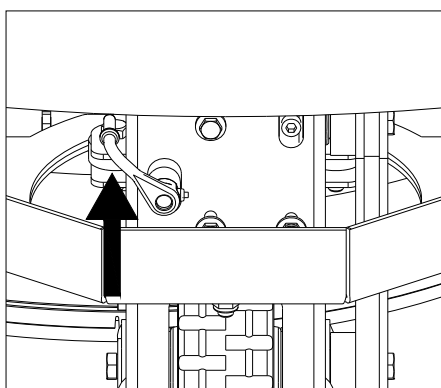
**Drive gear disengaged**

Machine can be pushed or towed (slowly).

When disengaged the machine rolls easily. Disengage on a level surface.

Rotate lever firmly in direction of arrow.

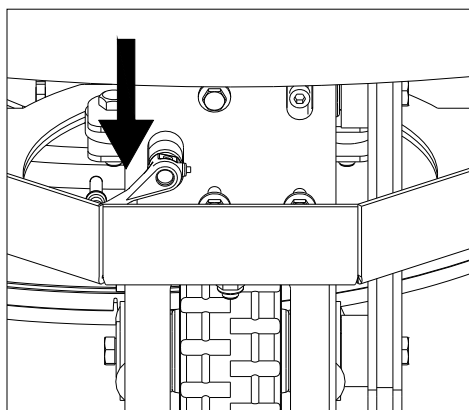
**Inclines**

When navigating an incline the machine may come to a stop. Turn the machine off. Wait 5 minutes and start the machine and proceed up the incline.

⚠ CAUTION:

Overheating may occur if you do not wait the full 5 minutes.

⚠ ATTENTION:

Une surchauffe peut se produire si vous n'attendez pas les 5 minutes complètes.

Preparation for Loading/Unloading Trailer

Burnisher Deck must be in the up position before loading.

When transporting the machine on a trailer or in a truck, in addition to using tie-downs, be sure to block the tires to prevent the machine from rolling.

Machine Tie-Downs

There are two tie points located in front of the rear wheels on the frame, and a Tie-down wrap point on the back panel. Tie-down devices must be of the proper type and strength. The combined strength of all tie-downs must be strong enough to lift two times the weight of the machine. Tie-downs must be positioned to prevent the machine from moving forward, backward, or either side to side. Use all four corners of the machine with the tie-downs running out opposite directions. Tie-downs must be attached to the transporting vehicle securely.

Recommended Tie-Down Points

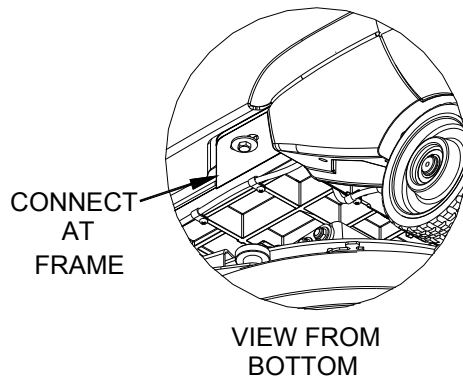
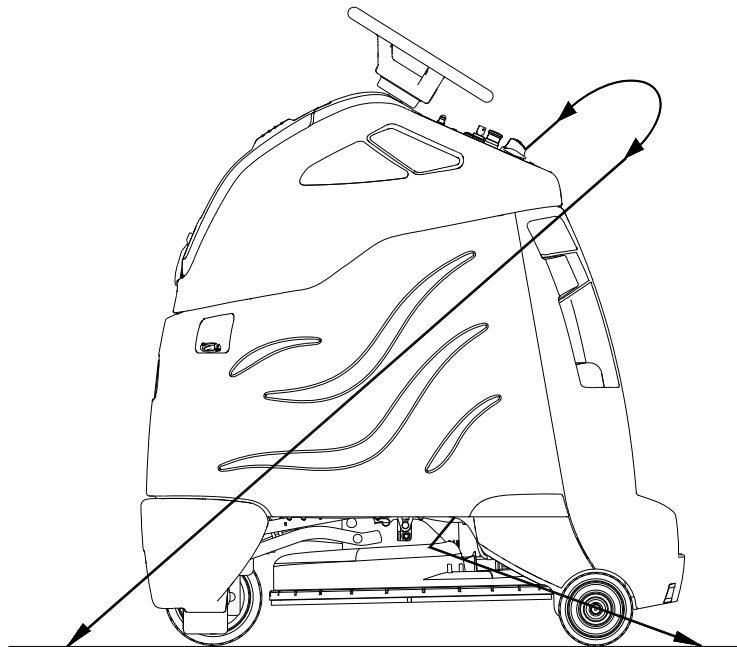

Troubleshooting

PROBLEM	CAUSE	SOLUTION
No machine function	Console lid is open	Close console lid
No power to machine	Battery disconnected	Check all battery cable connections
	Emergency shut-off activated	Reset
	Battery cables corroded	Clean connections
	Faulty key switch	Replace switch
	Batteries not plugged in	Plug batteries in
	On Board charger plugged in	Un-plug and stow cord
Little or no propel	Low battery charge	Charge batteries
	Tripped circuit breaker	Reset controller circuit breaker
	Controller protecting motor from overload	Controller limits motor amperage. Allow unit to cool down for several minutes.
	Machine is stalled against an obstacle (threshold, curb, etc.)	Remove obstacle or push machine away from obstacle
	Controller overheated	Allow cool down period
	Loose motor connection	Check wires and connections from controller to motor
	Faulty throttle circuit or potentiometer	Check wires and connections from and potentiometer resistance
	Drive Lever disengaged	Engage drive
Machine does not change speeds	Faulty speed control circuit or switch	Check wires & connections
Forward speed only	Faulty forward/reverse circuit	Check wires & connections
Reverse speed only		
Battery indicator light flashing	Battery needs charged	Charge Battery
	Controller is indicating a fault code	See fault code table

PROBLEM	CAUSE	SOLUTION
Vacuum motor does not run, or runs slowly	Faulty vacuum circuit or switch	Check wires & connections
	Worn vacuum motor brushes	Replace brushes, check commutator
	Vacuum circuit breaker tripped	Reset circuit breaker
Poor burnishing performance	Debris caught in pad	Remove debris or change pad
	Worn pad	Replace pad or flip pad
	Improper pad used	Contact equipment or application specialists
	Low battery charge	Charge batteries
Burnisher motor does not run, or runs slowly	Circuit breaker tripped	Reset circuit breaker
	Low battery charge	Charge battery
	Faulty brush circuit or motor	Check wires, connections and motor
	Worn brush motor brushes	Replace brushes, check commutator
Deck does not go down	Actuator circuit breaker tripped	Reset actuator circuit breaker

Battery Discharge Indicator Troubleshooting

The battery indicator flashes when a problem occurs. The table below list solutions for the indicated problems.

Number of flashes	Problem	Solution
1	The battery needs charging, there is a bad connection to the battery or dependent on the programming, may indicate that the battery lockout function is active and the controller is in a restricted mode of operation. Check the connections to the battery.	If the connections are good, try charging the battery.
2	There is a bad connection to the drive motor.	Check all connections between the motor and the controller.
3	The drive motor has a short circuit to a battery connection.	Contact your service agent.
4	The battery charge level has fallen below the battery Lockout Level and the controller is inhibiting burnisher motor function.	Charge the battery.
5	Not used.	-
6	The controller is being inhibited from driving, this may be because the battery charger is connected (on board charger only).	Disconnect battery charger.
7	A throttle fault is indicated.	Make sure that the throttle is in the rest position before switching on the machine.
8	A controller fault is indicated.	Make sure that all connections are secure.
9	The parking brake has a bad connection.	Check the parking brake and motor connections. Make sure the controller connections are secure.
10	An excessive voltage has been applied to the controller. This is usually caused by a poor battery connection.	Check the battery connections.
-	Blinks once every 5 seconds	Sleep mode, cycle key switch

Notes:

PARTS

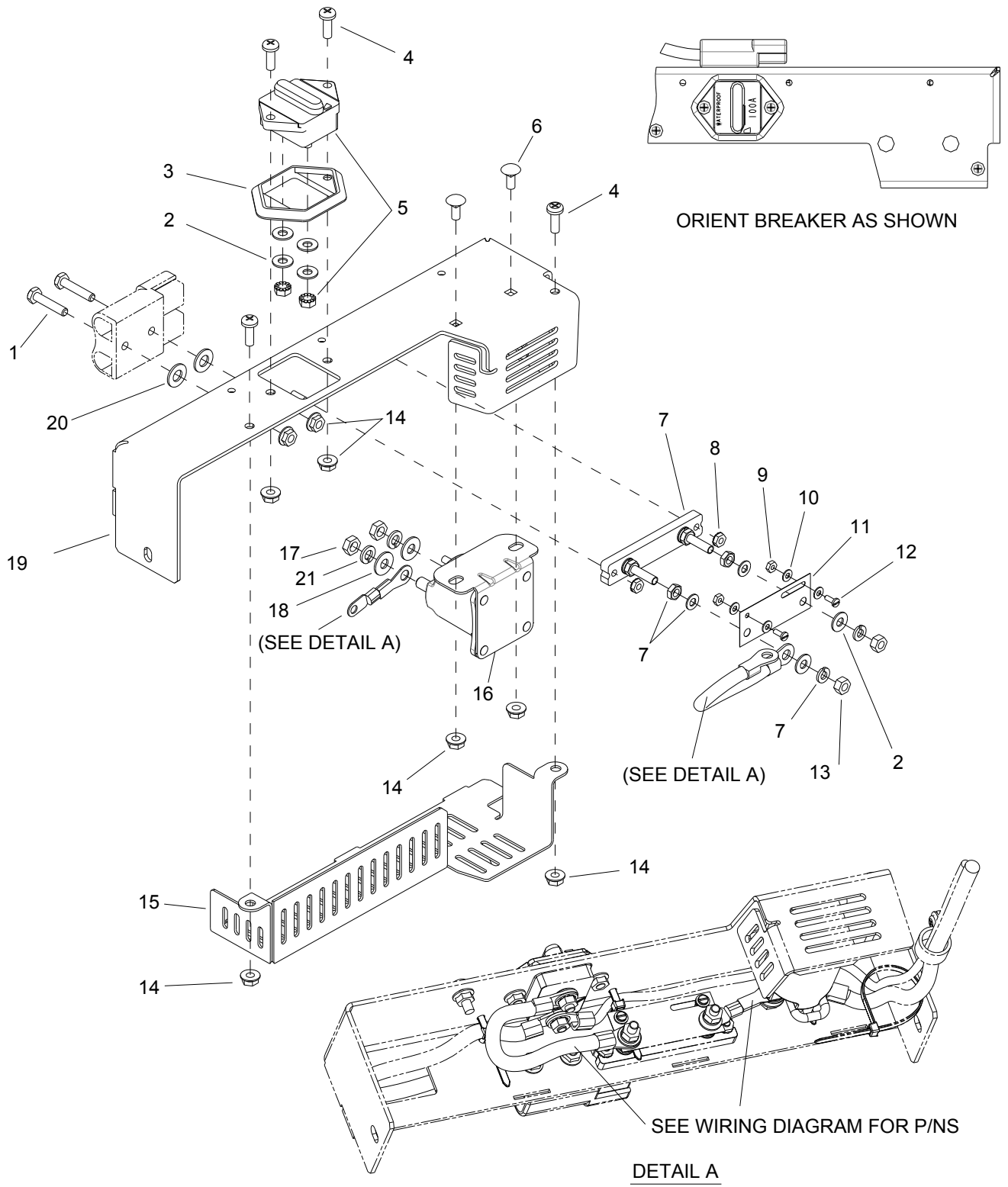

REF	PART NO.	QTY	DESCRIPTION	SERIAL NO. FROM	NOTES
1	86273820	2	SCREW 1/4-20 X 1.25 HHCS SS		
2	86010630	6	WASHER 1/4 ID X 5/8 OD SS		
3	86340020	1	COVER, PANEL MNT BREAKER		
4	86275120	4	SCR, 1/4-20 X.75 PPHMS PHIL		
5	86340030	1	BREAKER, 100A CIRCUIT		
6	86277500	2	SCR, 1/4-20 X 5/8 CARR SS		
7	86229770	1	BLOCK, SHUNT MOUNT		
8	86005700	2	NUT 10-32 W/STAR WASHER PLTD		
9	86271790	2	NUT, 6-32 HEX BRASS		
10	86279600	4	WASHER, #6 FLAT BRASS		
11	86253600	1	SHUNT, 50MV 70AMP		
12	86276250	2	SCR, 6-32 X 3/8 SRHMS BR		
13	86270770	2	NUT, 1/4-20 HEX		
14	86271370	8	NUT, 1/4-20 FLANGE LOCK		
15	86353270	1	BRACKET, CONTACTOR COVER		
16	86371450	1	RELAY 36VDC 100A HD	(7*)	
17	86271120	2	NUT, 5/16-18 BRASS		
18	86010670	2	WASHER, 5/16 FLAT SS		
19	86353260	1	BRACKET, SOL TANK BRACE		
20	86010680	2	WASHER 3/8 ID X 3/4 OD NYLON		
21	86279130	2	WASHER, 5/16 X .583 X .078 SPL STL ZNPLT		

* SEE SERIAL NUMBER PAGE

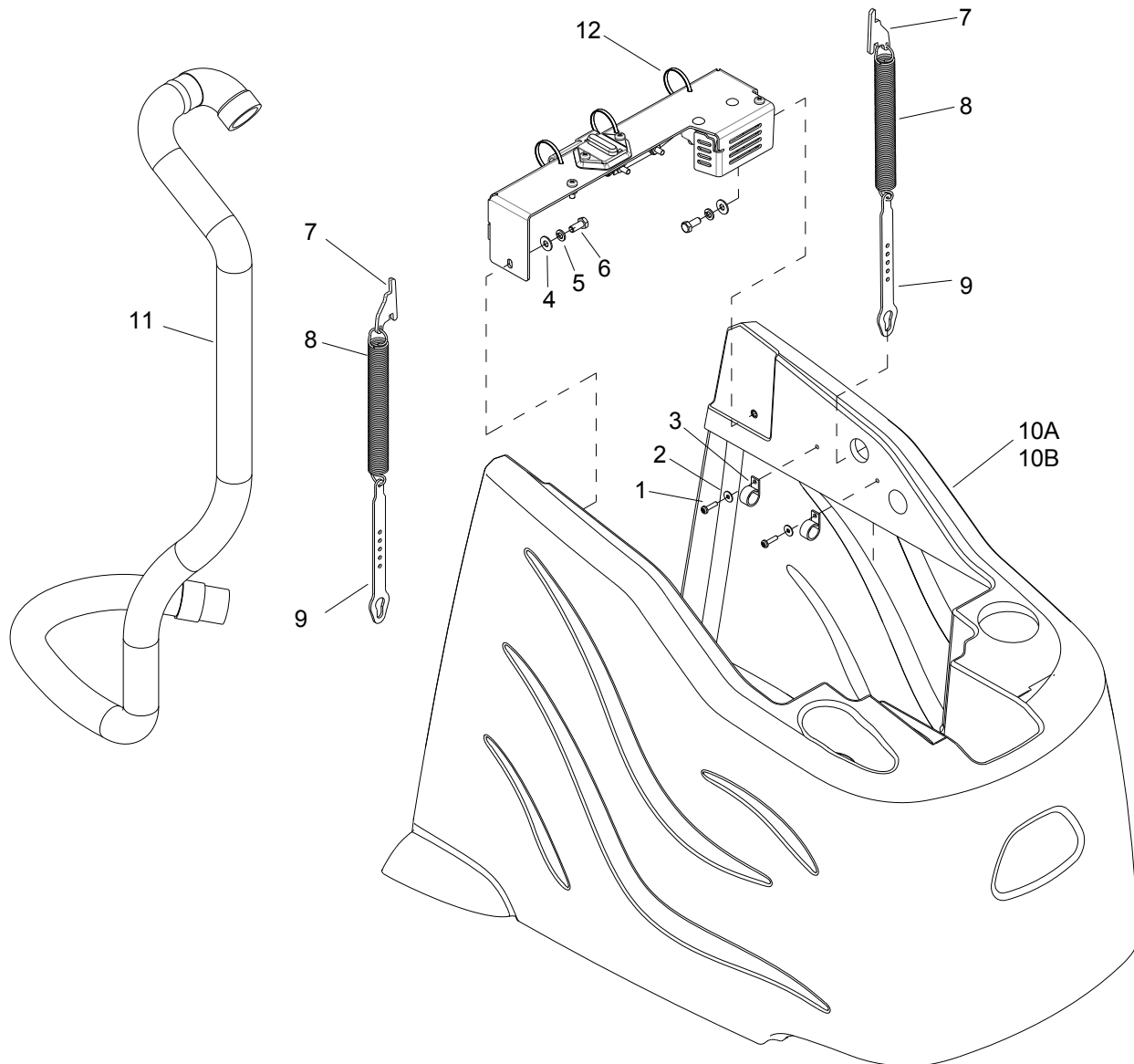

REF	PART NO.	QTY	DESCRIPTION	SERIAL NO. FROM	NOTES
1	86273980	2	SCREW 10-32 X 3/4 PPHMS SS		
2	86010650	2	SP WASHER #10 X 9/16 OD		
3	86354990	2	CLAMP, .75 DIA, FLEX LOOP, NYLON		
4	86010670	2	WASHER 5/16 FLAT SS		
5	86279130	4	WASHER 5/16 SPLIT LOCK PLTD		
6	86276780	2	SCR, 5/16-18 X 3/4 HHCS SS		
7	86354570	2	BRACKET, SPRING, UPPER		
8	86353220	2	SPRING, EXTENSION		
9	86353720	2	BRACKET, SPRING, LOWER		
10A	86353200	1	MAIN BODY, LB,OBC, TRIM		
10B	86358530	1	MAIN BODY, LB, NO OBC, TRIM		SHELF CHARGER MODELS ONLY, 1.002-033.0 1.002-035.0
11	86353280	1	HOSE 1.5" X 49", 4:1 STRETCH		
12	86264940	3	CABLE TIE 11.38" UL/CSA		

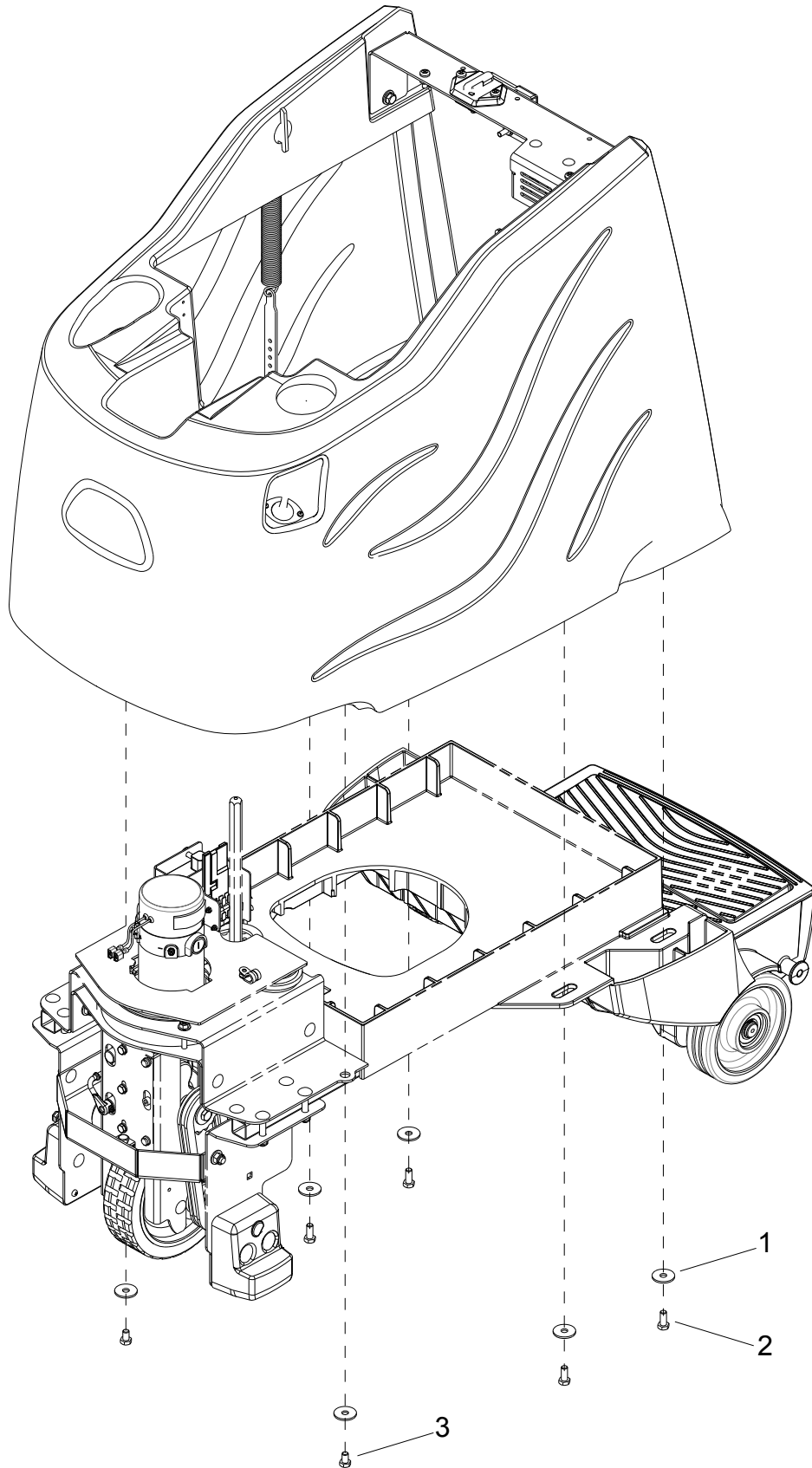

REF	PART NO.	QTY	DESCRIPTION	SERIAL NO. FROM	NOTES
1	86279630	6	WASHER, .344IDX1.13ODX.09T PLT		
2	86006760	4	SCREW 5/16-18 X 3/4HHCSGR5PLTDL		
3	86275180	2	SCR, 5/16-18 X 1/2 HHCS GR5 NP		

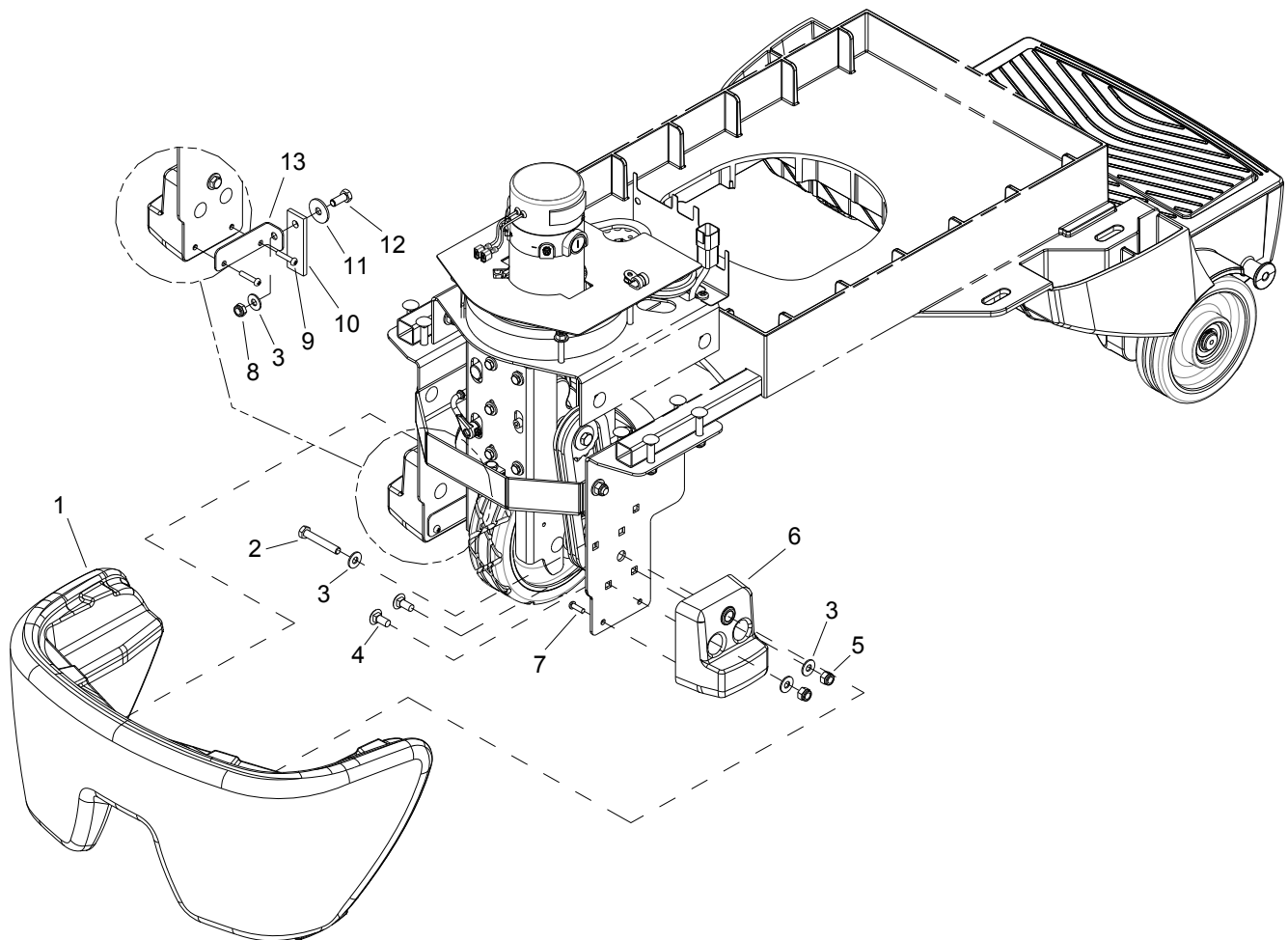

REF	PART NO.	QTY	DESCRIPTION	SERIAL NO. FROM	NOTES
1	86318180	1	BUMPER, TRIM, GRAY		
2	86276980	2	SCREW 5/16-18 X 2 HHCS SS		
3	86010670	7	WASHER 5/16 FLAT SS		
4	86276070	4	SCR, 5/16-18 X 3/4 CARRIAGE SS		
5	86270830	4	NUT 5/16-18 HEX NYLOCK SS		
6	86323950	2	PAD, TIP		
7	86327510	2	SCR, KA50X16, PT OHS, WN1412, A2 SS		
8	86271840	1	SP NUT 5/16-18 HEX NYLOCK THIN SS		
9	86327910	2	SCR, KA50X25, PT OHS, WN1412, PLTD		
10	86256130	1	STRAP, STATIC, .2T X 1W X 3L		
11	86279630	1	WASHER, .344IDX1.13ODX.09T PLT		
12	86006760	1	SCREW 5/16-18 X 3/4HHCSGR5PLTDL		
13	86359510	1	BRKT, STATIC STRAP		

Burnishing Deck

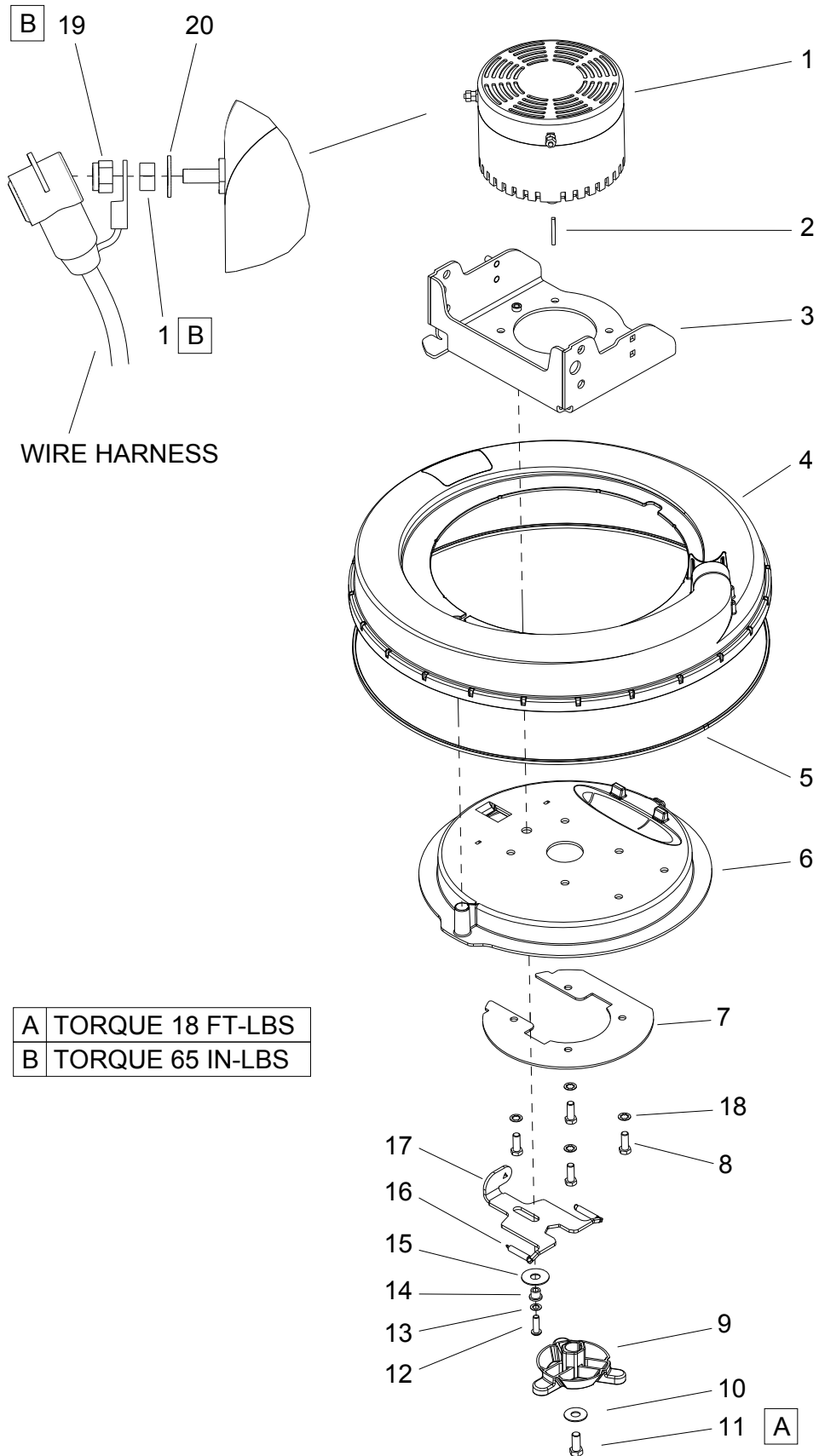

REF	PART NO.	QTY	DESCRIPTION	SERIAL NO. FROM	NOTES
1	86354980	1	MOTOR, 36VDC 3 HP 2000RPM		
-	86348010	1	BRUSH SET, BURNISHER MOTOR		
2	86286850	1	KEY, 3/16 SQ X 1.5" LONG		
3	86353470	1	BRACKET, MOTOR LIFT		
4	86352910	1	SHROUD, OUTER		
5	86353780	1	BRUSH, FLEXIBLE STRIP, 72" LONG		
6	86352900	1	SHROUD, INNER		
7	86353750	1	PLATE, SUPPORT, INNER SHROUD		
8	86276920	4	SCREW 3/8-16x1		
9	86372140	1	HUB, PAD DRIVER	(9*)	
10	86010710	1	WASHER .5 X 1.25 FLAT GR8 PLT		
11	86277540	1	SCREW 7/16-20 X 1 HHCS PLTD		
12	86006930	1	SCREW 5/16-18 X 1.00 BSHCS SS		
13	86330990	1	WASHER, 5/16 INT STAR, SS		
14	86228840	1	BEARING FLANGED.314IDX.502OD		
15	86279030	1	WASHER, .53 ID X 1.5 OD TEFLON		
16	86007910	2	SPRING EXT .31D X 2.0L X .03W		
17	86353760	1	BRACKET, MOTOR LOCK		
18	86279110	4	WASHER, 3/8 ID INT.LOCK		
19	86271910	2	NUT, 5/16-18 FLEXLOCK		
20	86010670	2	WASHER 5/16 FLAT SS		

*SEE SERIAL NUMBER PAGE

Burnishing Deck Mounting

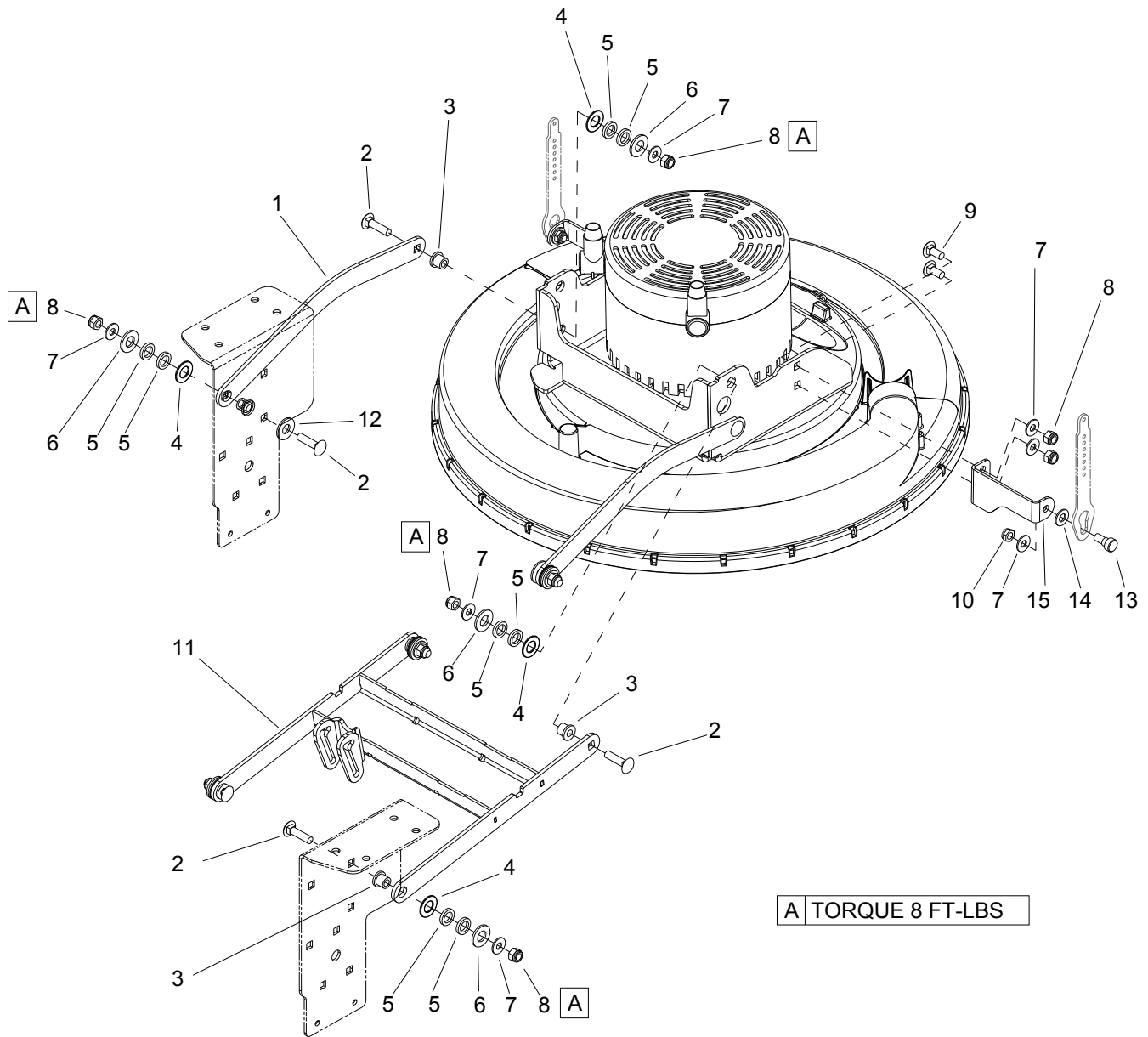

REF	PART NO.	QTY	DESCRIPTION	SERIAL NO. FROM	NOTES
1	86353790	2	BRACKET, LINKAGE ARM		
2	86277030	8	SCR, 5/16-18X1.25 CARRIAGE SS		
3	86228840	8	BEARING FLANGED.314IDX.502OD		
4	86259410	8	WASHER THRUST.51 ID X1ODX.063		
5	86279350	16	WASHER, WAVE 1/2ID X3/4D X.125		
6	86259420	8	WASHER, THRUST .51ID X 1 ODBRO		
7	86010670	14	WASHER 5/16 FLAT SS		
8	86270830	12	NUT 5/16-18 HEX NYLOCK SS		
9	86276070	2	SCR, 5/16-18 X 3/4 CARRIAGE SS		
10	86271840	2	SP NUT 5/16-18 HEX NYLOCK THIN SS		
11	86353740	1	BRACKET, LIFT ASSY, TOP		
12	86010770	2	WASHER 7/16ID X1DX.08 FLT SS		
13	86353810	2	BOLT SHOULDER, 3/8 OD X 1/4 L SS		
14	86010680	2	WASHER 3/8 ID X 3/4 OD NYLON		
15	86353800	2	BRACKET, SPRING LIFT		

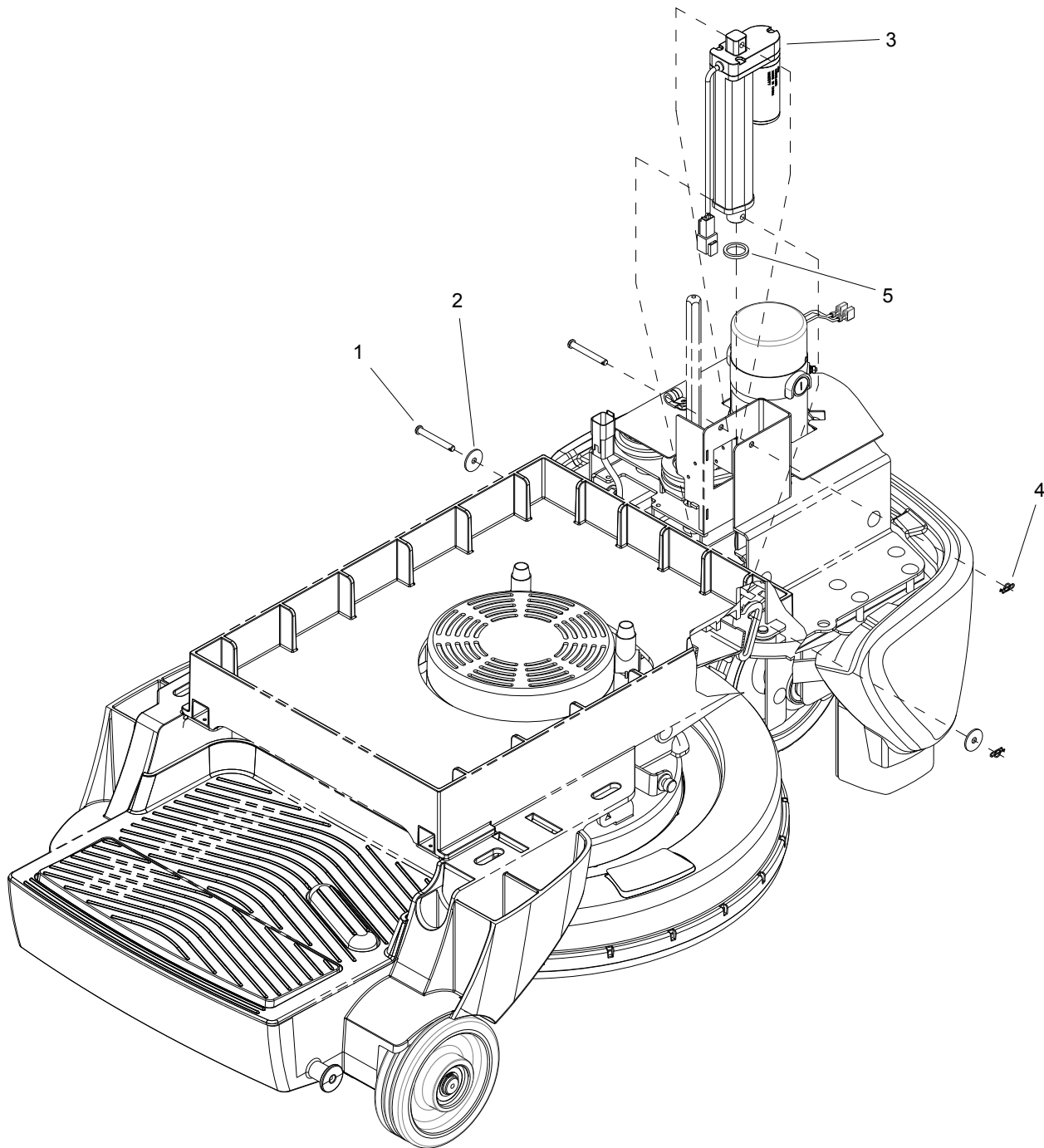

REF	PART NO.	QTY	DESCRIPTION	SERIAL NO. FROM	NOTES
1	86328040	2	PIN, CLEVIS, 1/4 X 2.0 L		
2	86354750	2	WASHER, 1.00X.264X.070THK, NYL, BLK		
3	86320880	1	ACT, 36VDC, 3.0" STK, 8.74 LNG		
4	86008650	2	COTTER 1/4" RING		
5	86342240	1	SPACER, .81 X 1.06 X .125		

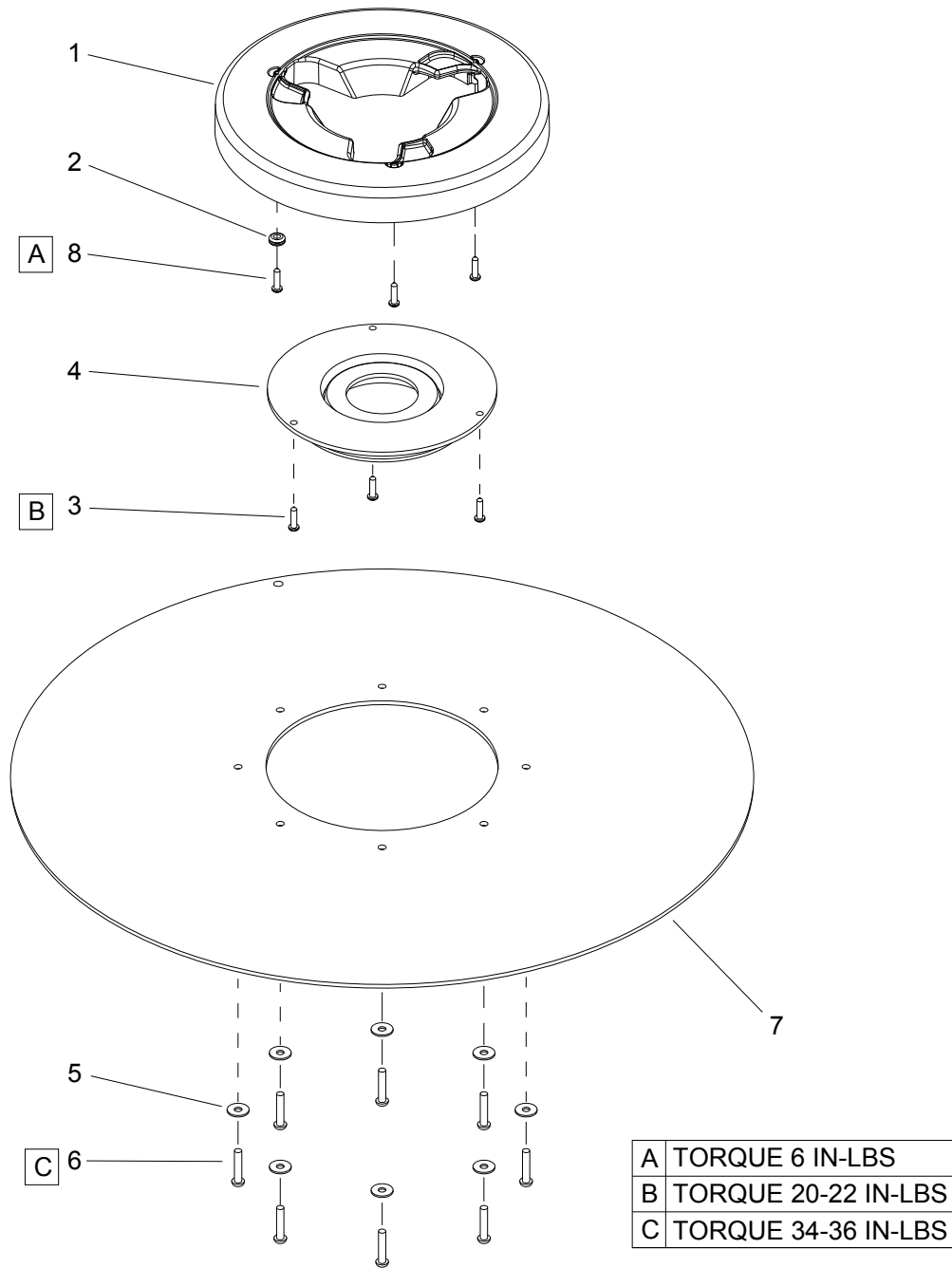

REF	PART NO.	QTY	DESCRIPTION	SERIAL NO. FROM	NOTES
1	86352460	1	HUB, PAD DRIVER		
2	86355650	1	GROMMET, .188ID x .438OD x .188T		
3	86173140	3	SCR, KA40X16,PT OVAL,WN1412,PL		
4	86355620	1	RETAINER, PAD CENTER LOCK		
5	86173330	8	WASHER, M5, FLAT, ISO7093, SS		
6	86327910	8	SCR, KA50X25, PT OHS, WN1412, PLTD		
7	86355610	1	PAD DRIVER, FACE 20"		
8	86351660	3	SCREW, 6-19 X .5 PHPNH HL STL ZNPLT		
-	86358450	-	ASM, PAD DRIVER iGLOSS 20		NOT SHOWN

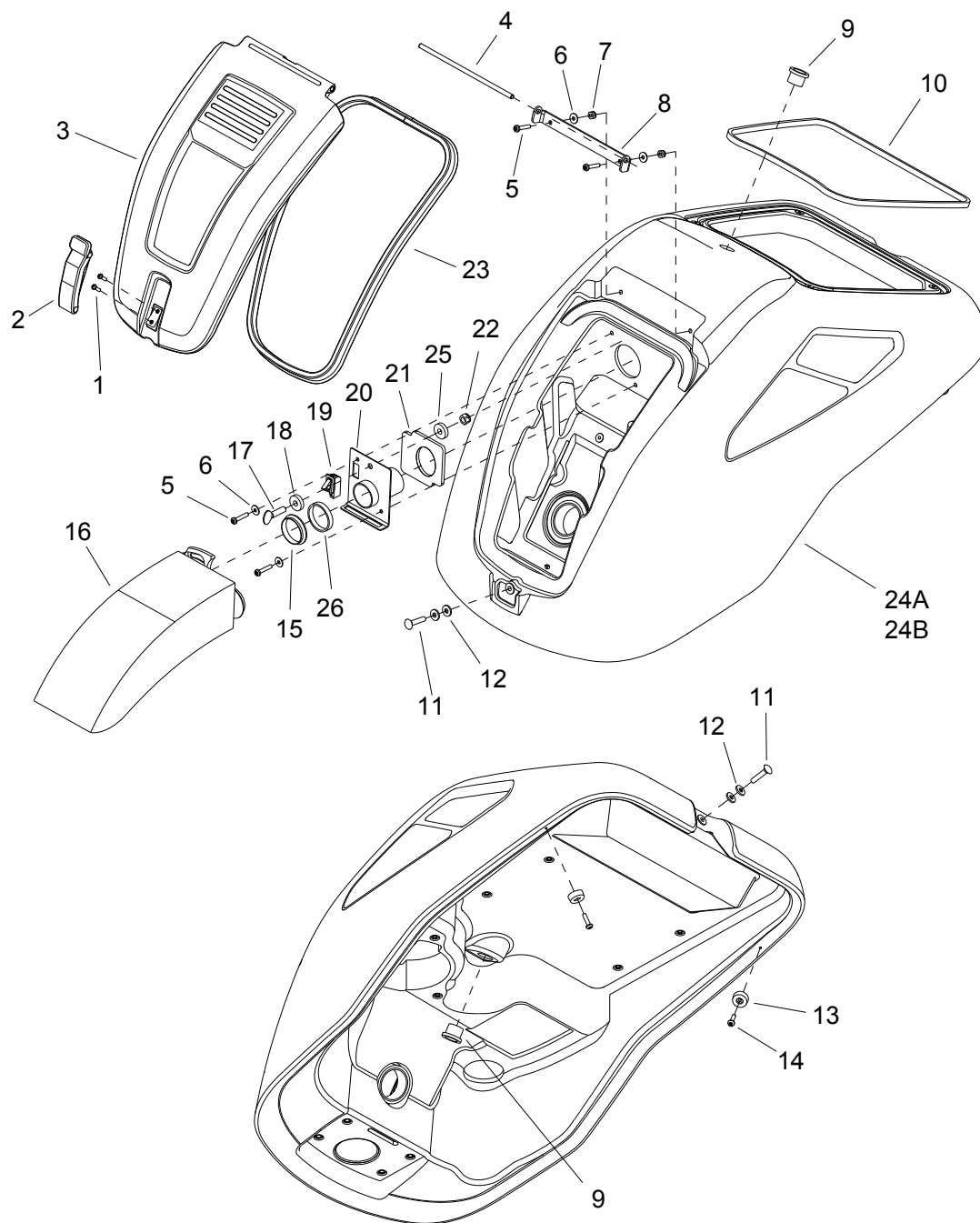

REF	PART NO.	QTY	DESCRIPTION	SERIAL NO. FROM	NOTES
1	86173140	2	SCR, KA40X16,PT OVAL,WN1412,PL		
2	86161800	1	CATCH CONCEALED KEEPER		
3	86353230	1	COVER, BAG ENCLOSURE		
4	86353650	1	SHAFT, .25 X 7.3, SS		
5	86275810	4	SCR, 10-32 X 1 PPHMS BLK		
6	86010650	4	SP WASHER #10 X 9/16 OD		
7	86005640	1	NUT 10-32 HEX NYLOCK		
8	86353170	1	BRKT, HINGE		
9	86228790	2	BEARING FLANGE .88ODX.75IDX.75		
10	86327830	1	GASKET,.188X.31X41.0		
11	86276330	2	SCR, 1/4-20 X 1.25 CARRIAGE BZ		
12	86279520	4	WASHER, 1/4 ID FLAT BLK		
13	86356130	2	BUMPER, 7/8OD X 13/32H, RUBBER		
14	86006600	2	SCREW #10 X 3/4 PPHST TYPE B SS		
15	86354640	1	WASHER, 1.5ID SINK, RUBBER		
16	86284790	1	FILTER BAG (10 PACK)		
17	86007040	1	SCREW 5/16-18X1 THUMB SS TYPE P		
18	86356820	1	WASHER, .315ID X .89OD X .215, NYL		
19	86327680	1	SWITCH, INTERLOCK		
20	86354590	1	BRACKET, BAG MOUNT		
21	86354630	1	GASKET, BAG MOUNT		
22	86271840	1	SP NUT 5/16-18 HEX NYLOCK THIN SS		
23	86353660	1	GASKET, BAG COVER, 43.6"		
24A	86353640	1	CONSOLE, iGLOSS 20, TRIMMED		ACTIVE DUST CONTROL
24B	86358550	1	CONSOLE, PASSIVE, TRIMMED		PASSIVE DUST CONTROL
25	86008320	1	SPACER, .314 X .59 X .36 NYLON		
26	86359260	1	WASHER, 1.5 ID X 1.7 PD X .19, RUBBER		

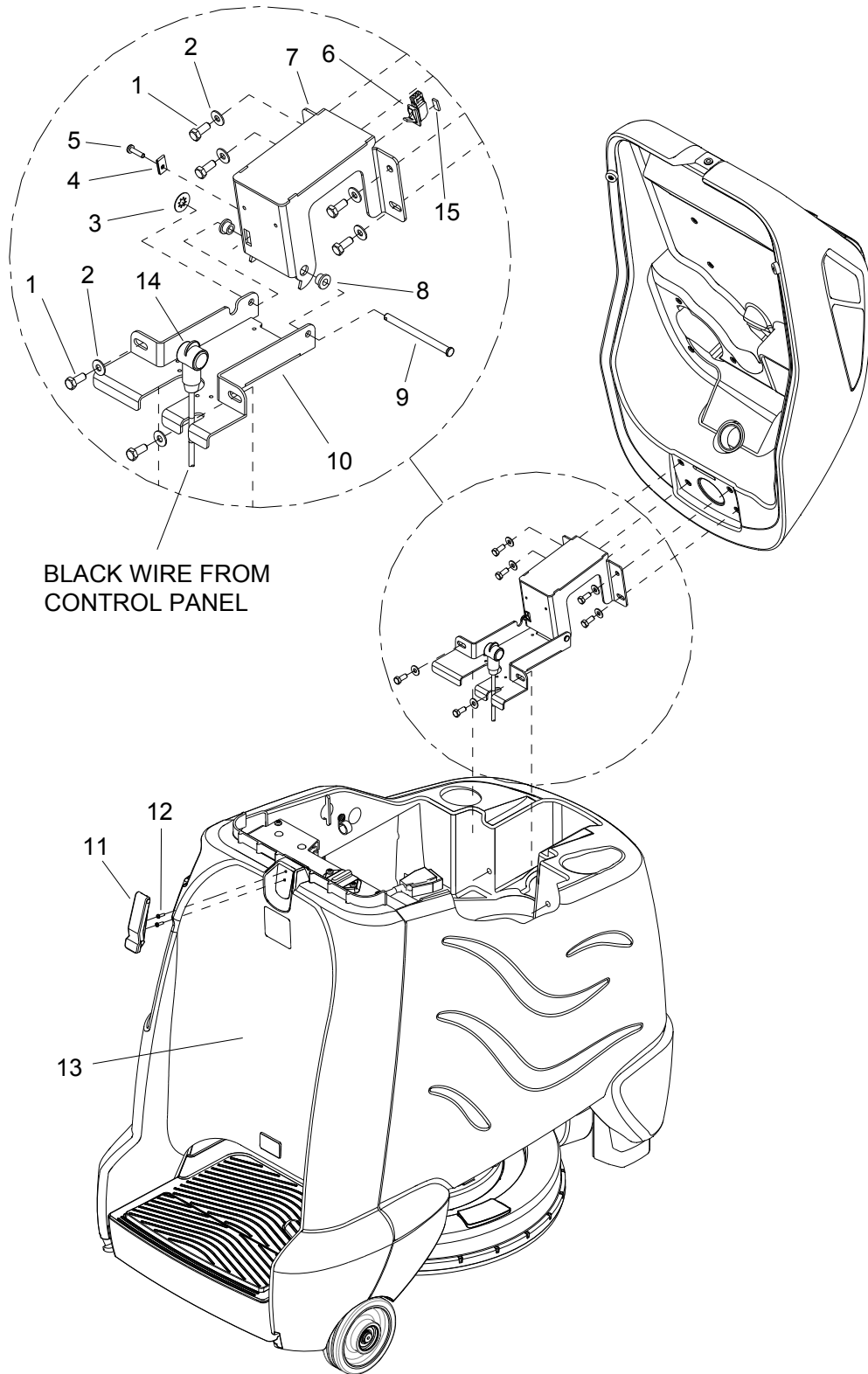

REF	PART NO.	QTY	DESCRIPTION	SERIAL NO. FROM	NOTES
1	86276780	6	SCR, 5/16-18 X 3/4 HHCS SS		
2	86010670	6	WASHER 5/16 FLAT SS		
3	86328860	1	NUT, 5/16 PUSH-LOCK, PLTD		
4	86270860	1	NUT, 10-24 U-TYPE SPEED		
5	86277110	1	SCR, 10-24 X 3/4 PPHMS SS		
6	86327680	1	SWITCH, INTERLOCK		
7	86326320	1	BRACKET, HINGE UPPER		
8	86228990	2	BEARING,FLNGD, .314ID X.502OD		
9	86326340	1	PIN, CLEVIS 5/16 X 4.0, PLTD		
10	86355010	1	BRACKET, HINGE LOWER		
11	86161800	1	CATCH CONCEALED KEEPER		
12	86173140	2	SCR, KA40X16,PT OVAL,WN1412,PL		
13	86354790	1	PANEL, BACK, TRIMMED		
14	86008920	1	BOOT, RUBBER TERM. ISOLATOR		
15	86402180	1	GASKET, .125 X .375 X .65		

A TORQUE 45-55 IN-LBS

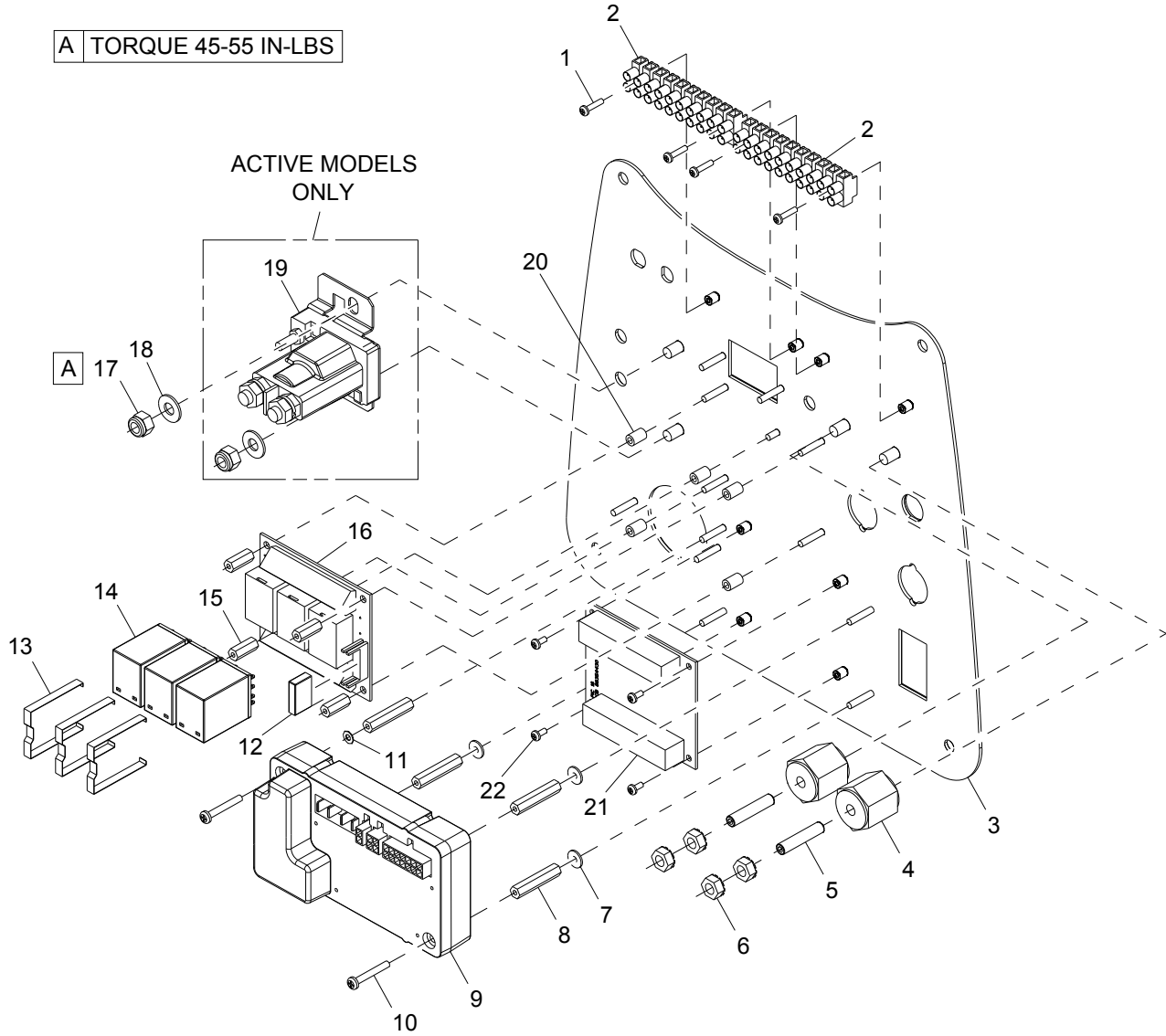

REF	PART NO.	QTY	DESCRIPTION	SERIAL NO. FROM	NOTES
1	86275260	4	SCR, 4-40 X 1/2 PPHMS		
2	86326390	2	CONN, 8MM PITCH, 10 POSN		
3	86352490	1	PANEL, CONTROL iGLOSS 20		
4	86255910	2	STANDOFF, 1/4-20 X 1.0 HEX INS		
5	86006850	1	SCR, 1/4-20 X 1.25 SSSCU		
6	86005710	4	NUT, 1/4-20 HEX W/STAR		
7	86279450	3	WASHER, #6 FLAT SAE PLTD		
8	86354860	4	STANDOFF, 6-32 X 1.25L, NYL		
9	86356320	1	CONTROLLER, iGLOSS 20		
10	86275550	2	SCREW 6-32 X 1.25		
11	86279020	1	WASHER #6 LOCK EXT STAR SS		
12	86336110	1	RELAY, SPST-NO		
13	86336100	3	CLIP, RELAY		
14	86313900	3	RELAY, 5A, 24V, 4PDT		
15	86255900	4	STANDOFF, 6-32 X 5/8 HEX NYL		
16	86347250	1	PCBA, RELAY OMRON II		
17	86005810	2*	NUT, 1/4-20 HEX NYLOCK SS		ACTIVE MODEL ONLY
18	86010630	2*	WASHER, 1/4 X 5/8 FLAT SS		ACTIVE MODEL ONLY
19	86251360	1	RELAY, 36VDC, 100A		ACTIVE MODEL ONLY
20	86337210	5	SPACER, .141D X .250D X .38, NYL		
21	86354430	1	PCB, ROTARY SWITCH		
22	86274570	4	SCR, 4-40 X 1/4 PPHMS		

* QUANTITY OF 1 FOR PASSIVE MODEL

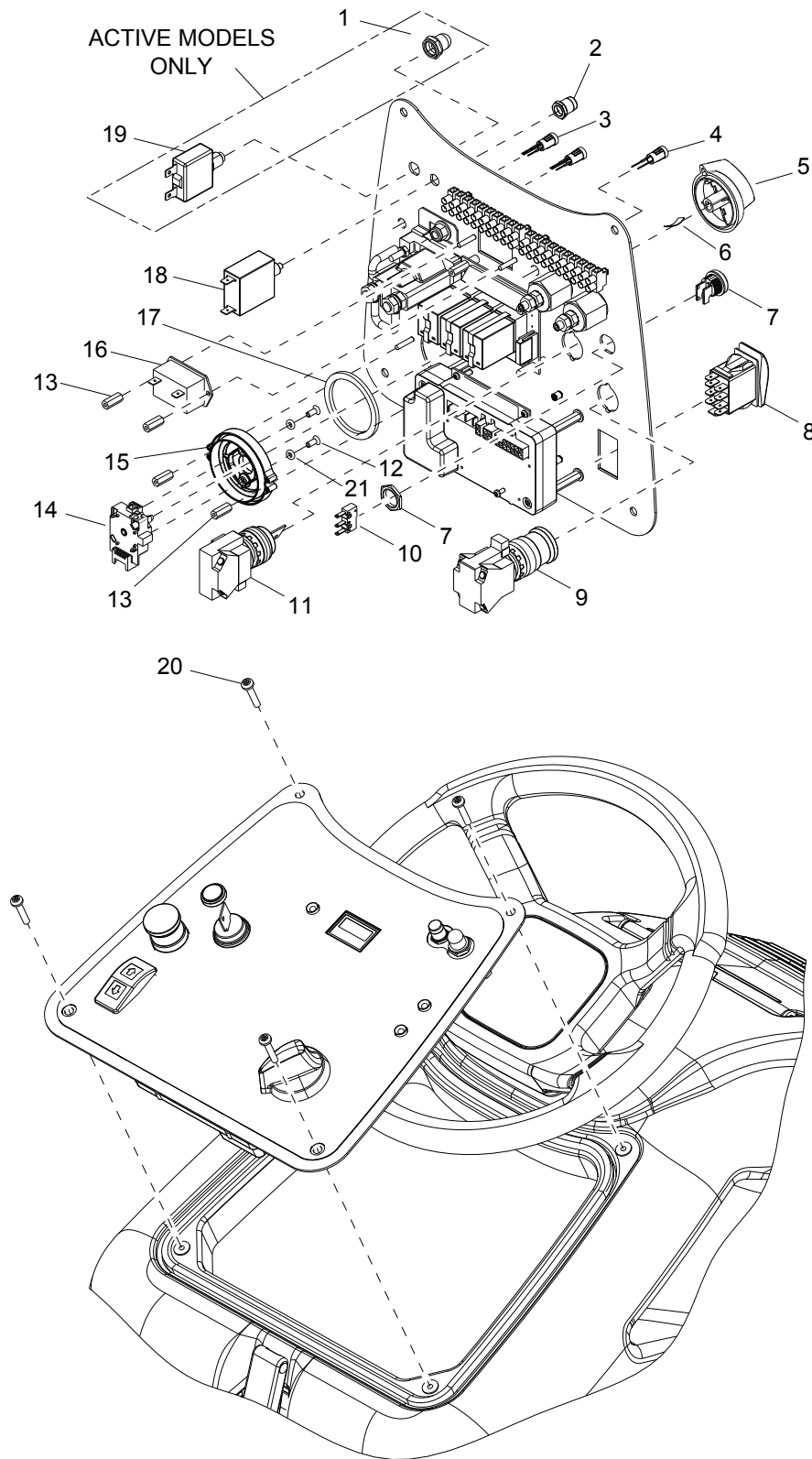

REF	PART NO.	QTY	DESCRIPTION	SERIAL NO. FROM	NOTES
1	86332510	1	BOOT, SEAL PUSH BUTTON 11MM		ACTIVE MODEL ONLY
2	86001260	1	BOOT, CB 3/8-32 UNS		
3	86348640	2	LED, BAG FULL INDICATOR		
4	86348960	1	LED, BATTERY INDICATOR		
5	53217380	1	KNOB, SELECTION		
6	63130140	1	SPRING ELEMENT		
7	86295200	1	ASM, BUTTON, BLACK, W/BEZEL		
8	86313950	1	SWITCH, SPDT 3 POSN MOM, ARROW		
9	86292590	1	SWITCH, E-STOP AKW CHARIOT		
10	86292780	1	SWITCH,MICRO		
11	86007170	1	SWITCH, KEY 2 POSITION		
12	86358430	2	SCR, M4X12 FHMS, ISO7046 SS NP		
13	86255900	4	STANDOFF, 6-32 X 5/8 HEX NYL		
14	86354870	1	SWITCH, ROTARY		
15	86354560	1	BEZEL, ROTARY SWITCH		
16	86315470	1	METER, HOUR, LCD		
17	86354810	1	GASKET, SCE42B W/5008B PSA		
18	86353680	1	BREAKER, 1.5A, CARLING MAGNETIC		
19	86316160	1	BREAKER, 18A, 250VAC, 32VDC		ACTIVE MODEL ONLY
20	86329570	4	SCR, PAN HD #10-32 X 1.0 TORX, SS NP		
21	86358440	2	O-RING, 4MM ID, 1.5MM THK, BUNA-N		

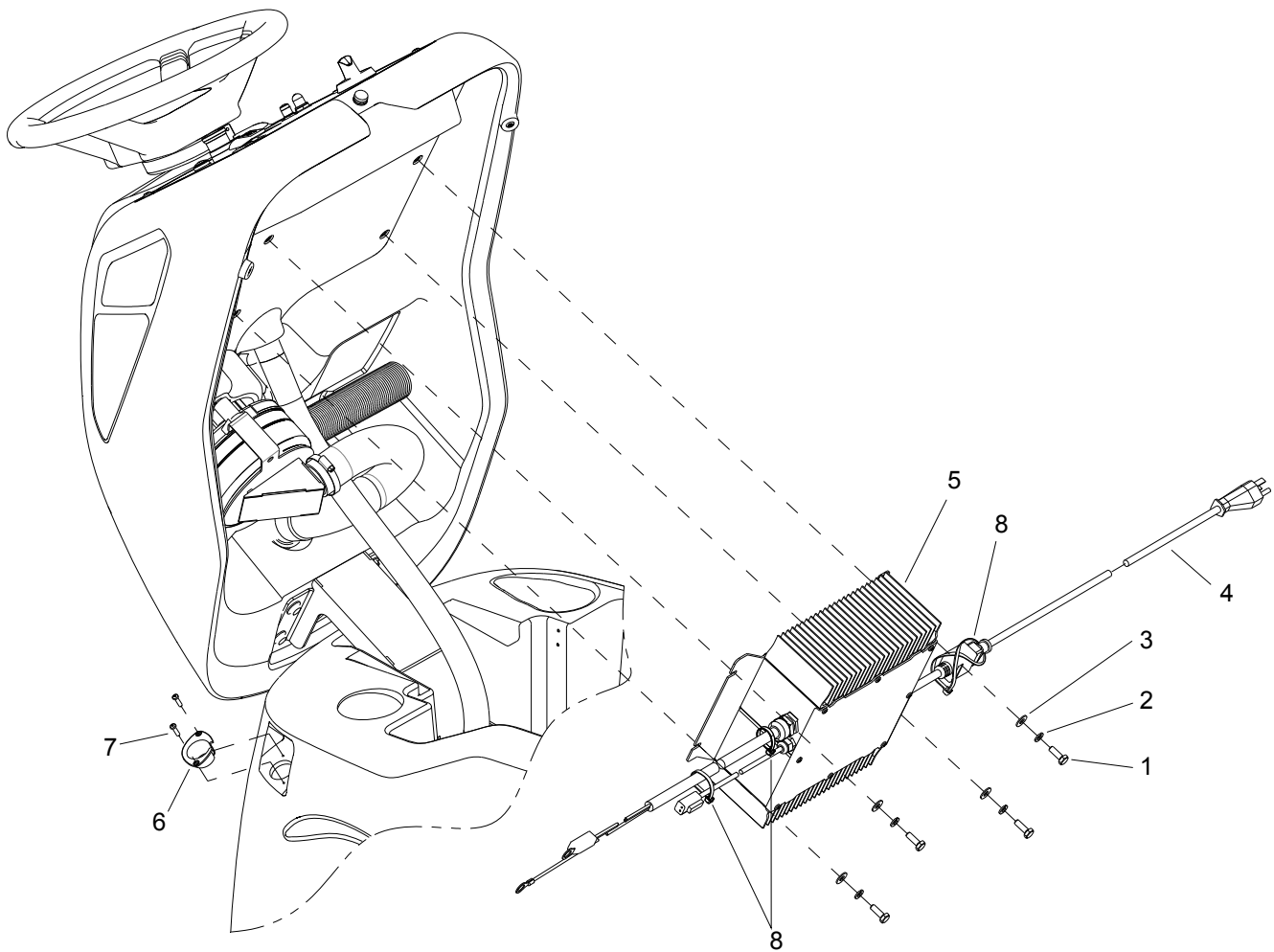

REF	PART NO.	QTY	DESCRIPTION	SERIAL NO. FROM	NOTES
1	86273780	4	SCR, 1/4-20 X 3/4 HHCS SS NP		
2	86010780	4	WASHER 1/4 SPLIT LOCK PLTD		
3	86010630	4	WASHER 1/4 ID X 5/8 OD SS		
4	86234390	1	SP CORD ASM, 16/3 SJTW X 2M IEC		
5	86353300	1	CHARGER, 36V 21A, OBC, 4 PROFILE		
6	86344430	1	GROMMET, CHARGE PLUG		
7	86173140	2	SCR, KA40X16,PT OVAL,WN1412,PL		
8	86264940	3	CABLE TIE, 11.38" UL/CSA		

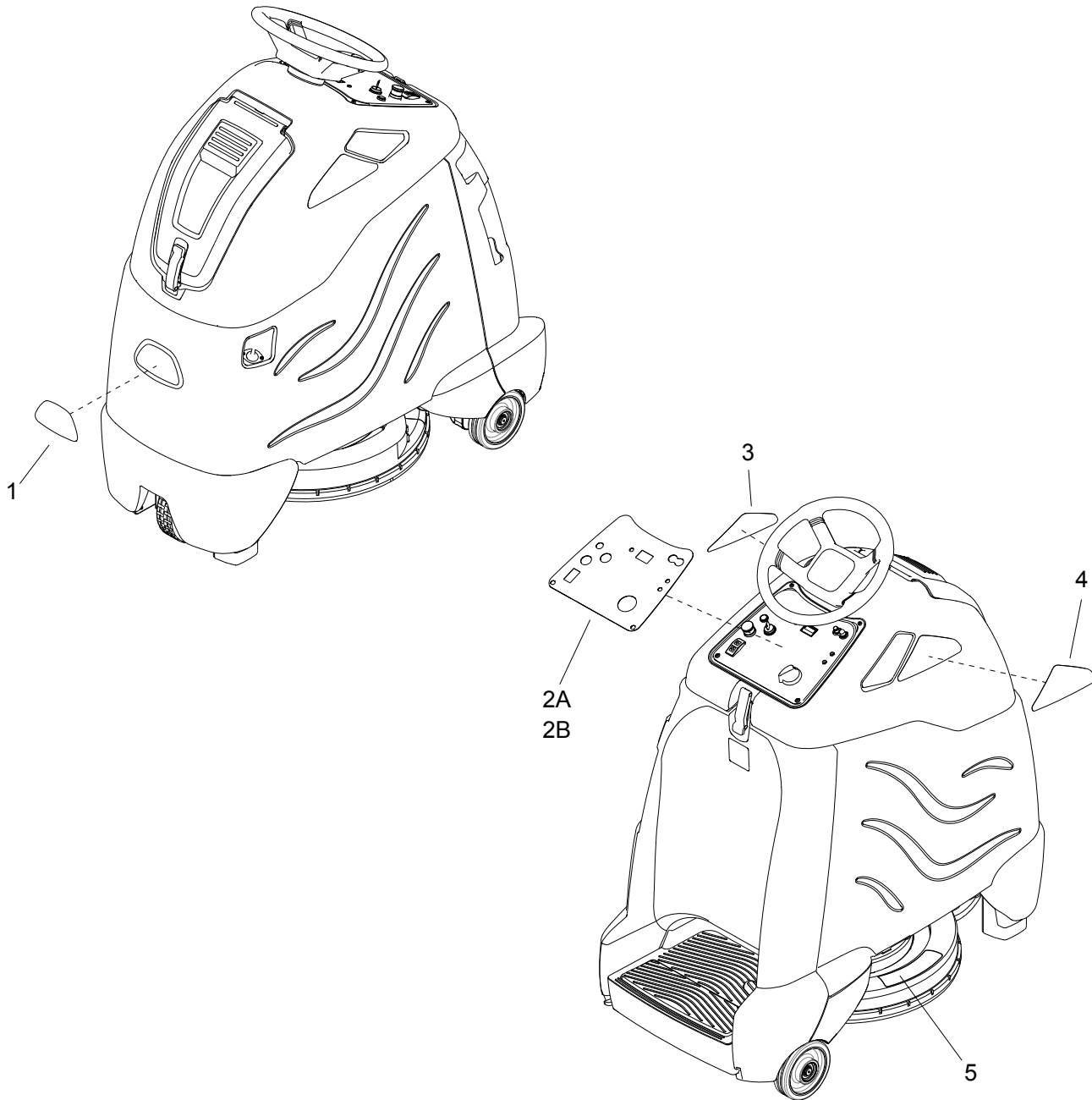

REF	PART NO.	QTY	DESCRIPTION	SERIAL NO. FROM	NOTES
1	86004970	1	LABEL WINDSOR LOGO DOMED		
2A	86353580	1	LABEL, PANEL, iGLOSS 20, DLX		ACTIVE MODELS
2B	86357750	1	LABEL, PANEL iGLOSS 20		PASSIVE MODELS
3	86354330	1	LABEL, iGLOSS 20 LEFT		
4	86354340	1	LABEL, iGLOSS 20 RIGHT		
5	86363810	1	LABEL, BURNISHER SHROUD		

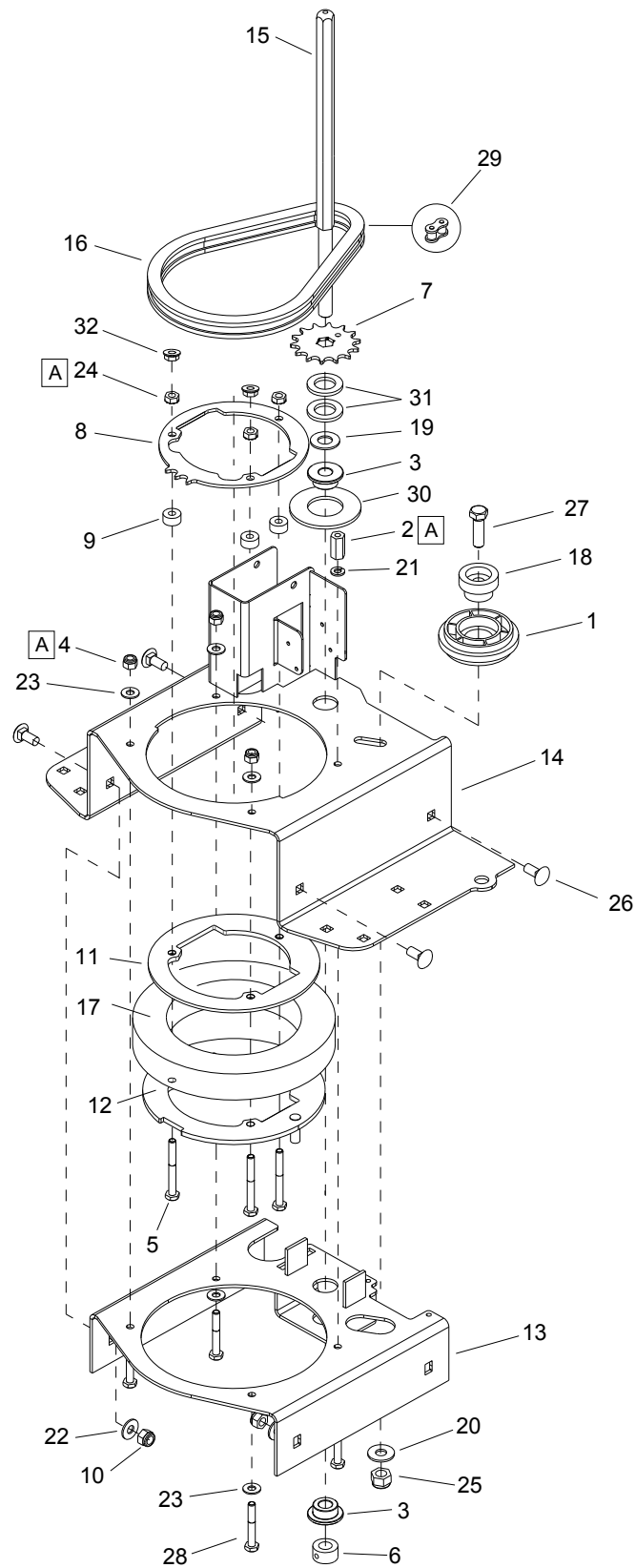

A | TORQUE 6-7 FT-LBS

REF	PART NO.	QTY	DESCRIPTION	SERIAL NO. FROM	NOTES
1	86330720	1	CHAIN TENSIONER		
2	86329350	1	NUT, 1/4-20 X 7/8 HEX COUPLING SS		
3	86328050	2	WASHER, SHOULDER.48ID X 1.25OD		
4	86005810	3	NUT, 1/4-20 HEX NYLOCK SS		
5	86273100	3	SCR, 1/4-20X2-1/4 HXHD CAP		
6	86322060	1	COLLAR, 12MM ID		
7	86322050	1	SPROCKET, STEERING, 14T		
8	86322040	1	PLATE, CHAIN RING		
9	86322030	3	SPACER		
10	86270830	7	NUT, 5/16-18 HEX NYLOCK SS		
11	86319740	1	PLATE, UPPER CLAMP		
12	86319680	1	PLATE, LOWER CLAMP		
13	86319610	1	BRACKET, BEARING CLAMP		
14	86319600	1	BRACKET, DRIVE MOUNT		
15	86319590	1	SHAFT, STEERING SPROCKET		
16	86319560	1	CHAIN, ISO O8B, 12.7MM PITCH		
17	86014440	1	BEARING, DRIVE		
18	86224270	1	SLEEVE, CHAIN TENSIONER		
19	86259430	1	WASHER, 12.5 ID X 26 OD X 2T FLAT		
20	86279510	1	WASHER, 3/8 X 1 FLAT NP		
21	86010780	1	WASHER, 1/4 SPLIT		
22	86010670	4	WASHER, 5/16 X 3/4 SS		
23	86010630	7	WASHER, 1/4 X 5/8 FLAT SS		
24	86005710	3	NUT, 1/4-20 HEX W/STAR		
25	86271930	1	NUT, 3/8-16 HEX NYLOCK SS		
26	86276070	4	SCR, 5/16-18 X 3/4 CARRIAGE SS		
27	86275190	1	SCR, 3/8-16 X 1.25 HHCS SS		
28	86274150	4	SCR, 1/4-20 X 1.75 HHCS		
29	86232780	-	CHAIN MASTERLINK 12.7MM		
30	86368600	1	WASHER, 2.5 OD X 1.25 ID X .125 THK, DELRIN		
31	86279420	2	WASHER .75IDX1.25ODX.125THK NY		
32	86271370	2	NUT, 1/4-20 SERFLG STL ZNPLT		

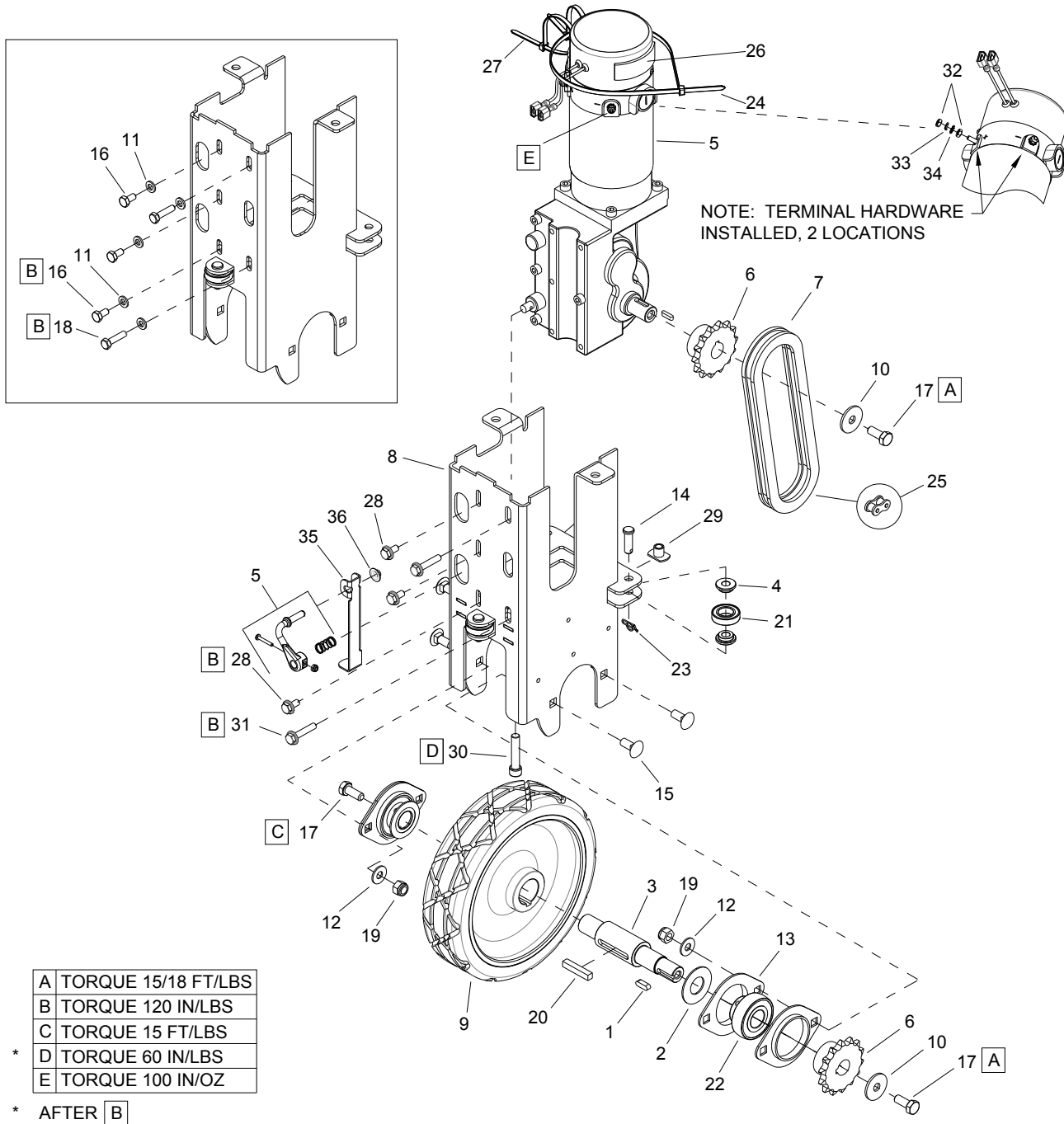

REF	PART NO.	QTY	DESCRIPTION	SERIAL NO. FROM	NOTES
1	86326710	1	KEY, 5 X 5 X 16		
2	86321670	2	WASHER, WHEEL SPACER		
3	86319810	1	AXLE, DRIVE WHEEL		
4	86319670	6	SLEEVE, BEARING		
5	86364010	1	MOTOR, TRACTION	(4*)	▲
-	86378440	1	KIT, BRUSHES, DRIVE MOTOR		● NOT SHOWN
-	98408960	-	BRAKE REPLACEMENT SMALL STAND ON		NOT SHOWN
6	86319650	2	SPROCKET, DRIVE, 14T		
7	86319640	1	CHAIN, ISO O8B, 12.7MM PITCH		
8	86319620	1	FRAME, LOWER DRIVE		
9	86369170	1	WHEEL, 8.00 X 2.00, GRAY X-GRV	(6*)	
10	86279630	3	WASHER, .344IDX1.130ODX.09T PLT		
11	86358800	5	WASHER, M6 CONICAL		
12	86010670	4	WASHER, 5/16 X 3/4 SS		
13	86008610	4	FLANGE, BEARING PRESSED STEEL		
14	86272550	3	PIN, CLEVIS, 5/16 X 1.00 PLTD		
15	86276070	4	SCR, 5/16-18 X 3/4 CARRIAGE SS		
16	86358820	3	SCREW, M6-1.0 X 16 HCS 10.9Z		
17	86136640	3	SCR, M8 X 20 HHMS		
18	86358810	2	SCREW, M6 - 1.0 X 30 HCS 10.9Z		
19	86270830	4	NUT, 5/16-18 HEX NYLOCK SS		
20	86219640	1	KEY, 1/4 SQ. X 1.5		
21	86332380	3	ROLLER, 1.1 OD		
22	86001030	2	BEARING, BALL 3/4 BORE SPHERED		
23	86008660	3	COTTER 5/16" RING		
24	86002830	1	CABLE TIE .375 X 24.7		
25	86232780	-	CHAIN MASTER LINK 12.7MM		NOT SHOWN
26	86362040	2	TAPE CLOSED CELL 1/8 X 3/4 X 2 1/2 PSA	(1*)	
27	86264920	2	CABLE TIE, 7" UL/CSA	(1*)	
28	86362140	3	SCREW, M6 X 12MM, HEX FLANGE, PLTD	(3*)	
29	86348490	1	NUT, WELD 5/16-18 X .38, TAB BASE, STL	(3*)	
30	86362130	1	SCREW, 5/16 X 1.50, SHCS, SS, FT	(3*)	
31	86362150	2	SCREW, M6 X 30MM, HEX FLANGE, PLTD	(3*)	
32	86288500	4	NUT, M4-.7 HEX STL CL8 ZNPLT		
33	86134850	2	WASHER, SPRNG LK, M4, DIN127B, SST		
34	86372230	2	WASHER, EXT TOOTH STAR		
35	86333870	1	LEVER, DRIVE ENGAGEMENT		
36	86271240	1	NUT, 1/4 PAL STL ZNPLT		

* SEE SERIAL NUMBER PAGE

- ▲ For installation of 8.636-401.0 with brake harness and lower harness, order kit 8.636-900.0
- For CCL traction motor, use 86331990 brush set.
For Linix traction motor, use 86378410 brush set.
Both sets included in kit.

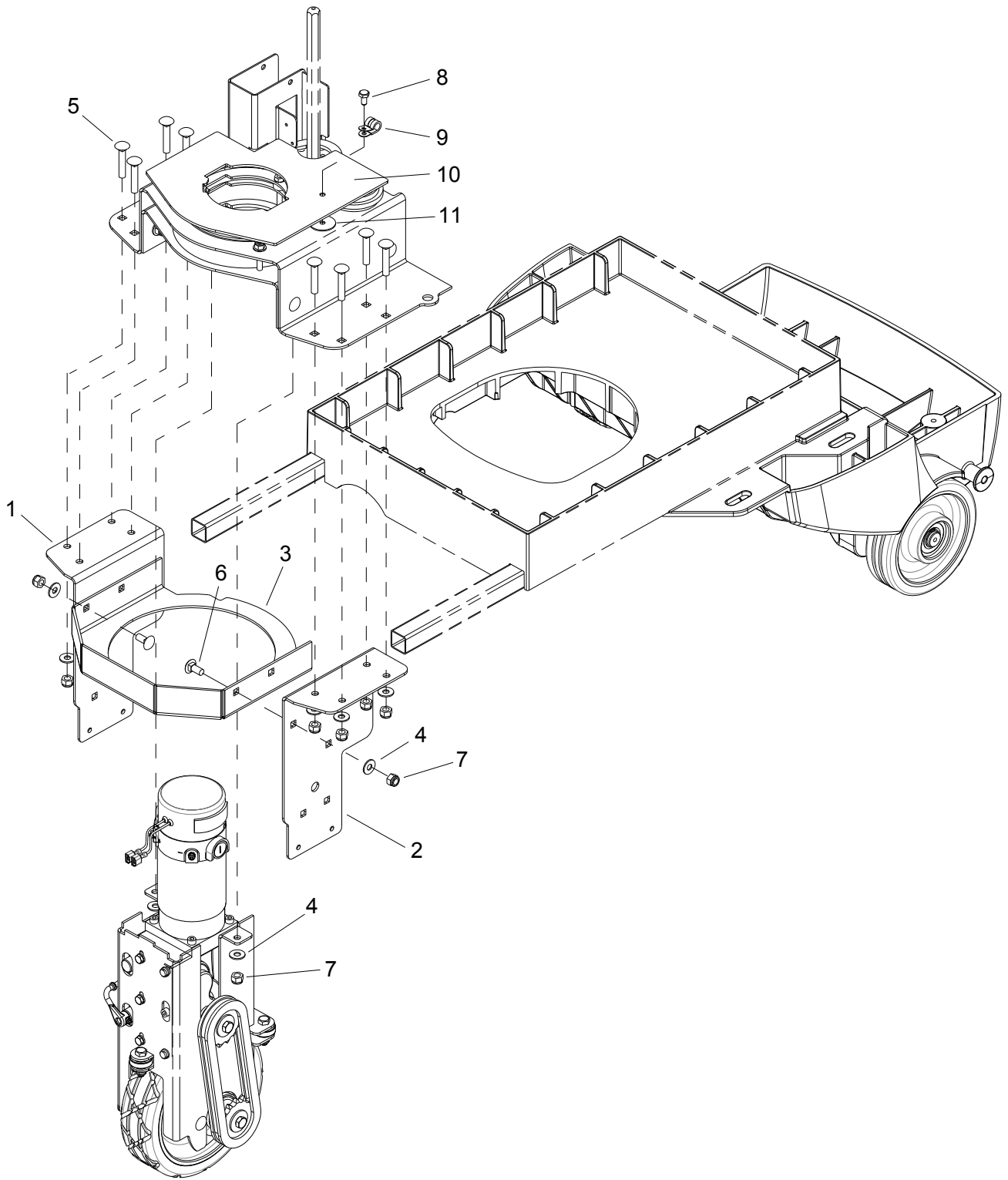

REF	PART NO.	QTY	DESCRIPTION	SERIAL NO. FROM	NOTES
1	86344620	1	BRACKET, LINKAGE MOUNT		
2	86319730	1	BRACKET, LINKAGE MOUNT, LEFT		
3	86331630	1	BRACKET, ROLLER GUIDE		
4	86010670	12	WASHER, 5/16 X 3/4 SS		
5	86276690	8	SCR, 5/16-18 X 1.75 CARR SS		
6	86276070	2	SCR, 5/16-18 X 3/4 CARRIAGE SS		
7	86270830	12	NUT, 5/16-18 HEX NYLOCK SS		
8	86274760	1	SCR, 1/4-20 X 1/2 HHCS		
9	86363870	1	CLAMP, 5/8" OD CUSHIONED		
10	86329340	1	PLATE, CHAIN GUARD		
11	86278940	1	WASHER 1/4 ID X 1-1/4 OD PLT	(1*)	

Frame & Rear Wheels

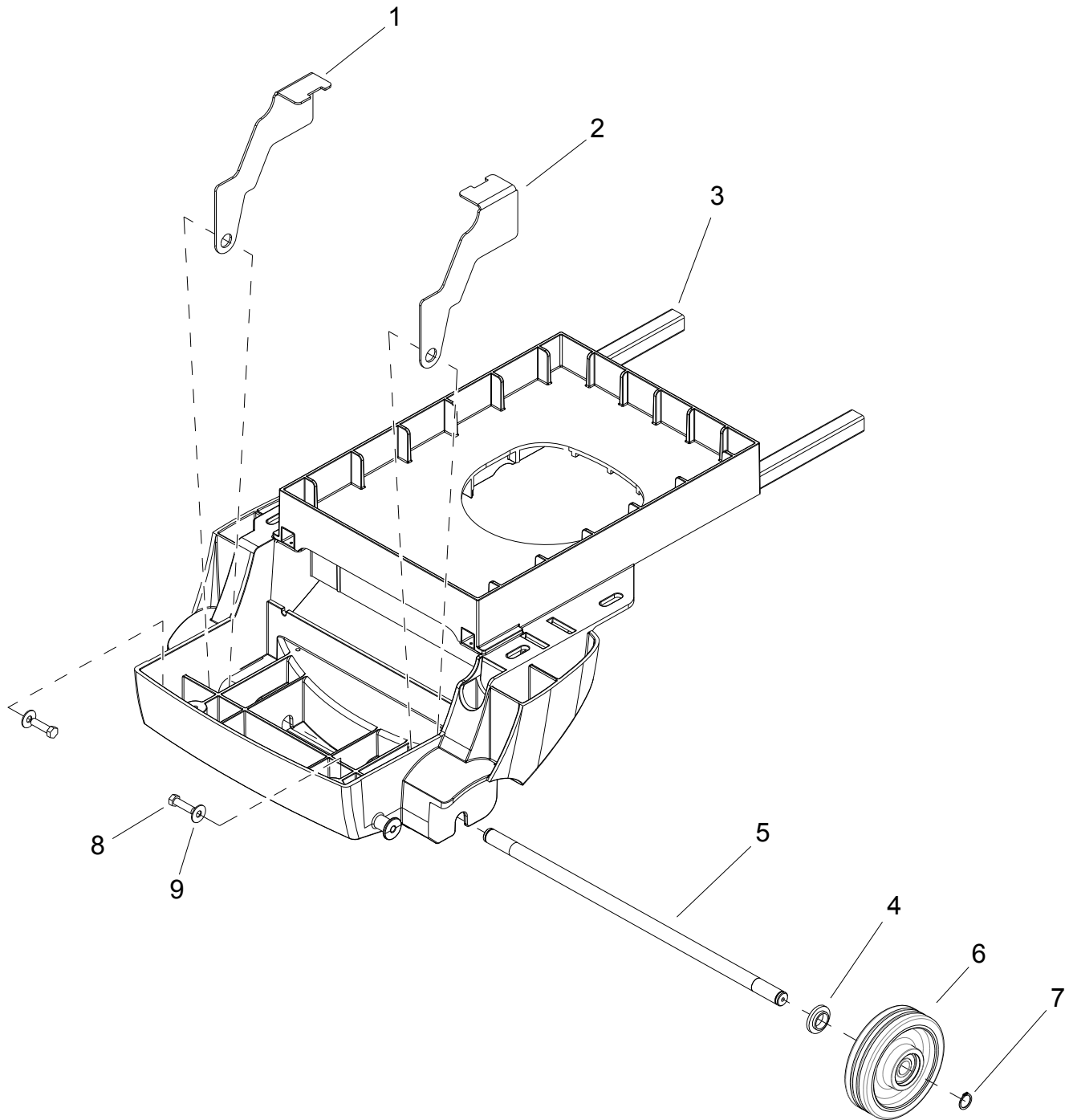

REF	PART NO.	QTY	DESCRIPTION	SERIALNO. FROM	NOTES
1	86326260	1	BRACKET, FRAME LEFT		
2	86326250	1	BRACKET, FRAME RIGHT		
3	86356380	1	FRAME ASM IGLOSS 20		INCLUDES ITEM 8 & 9
4	86326220	2	SPACER, FLG .887ID X 1.055D X .345LG		
5	86318030	1	AXLE, 20MM X 562 MM		
6	86369160	2	WHEEL, 6.00X1.58, GRY W/ BEARINGS	(8*)	
7	86223470	2	RING, 20MM EXTERNAL SNAP		
8	86279510	2	WASHER 3/8 FLAT		
9	86340950	2	SCR, 3/8 X 1.5, LAG, PLTD		

* SEE SERIAL NUMBER PAGE

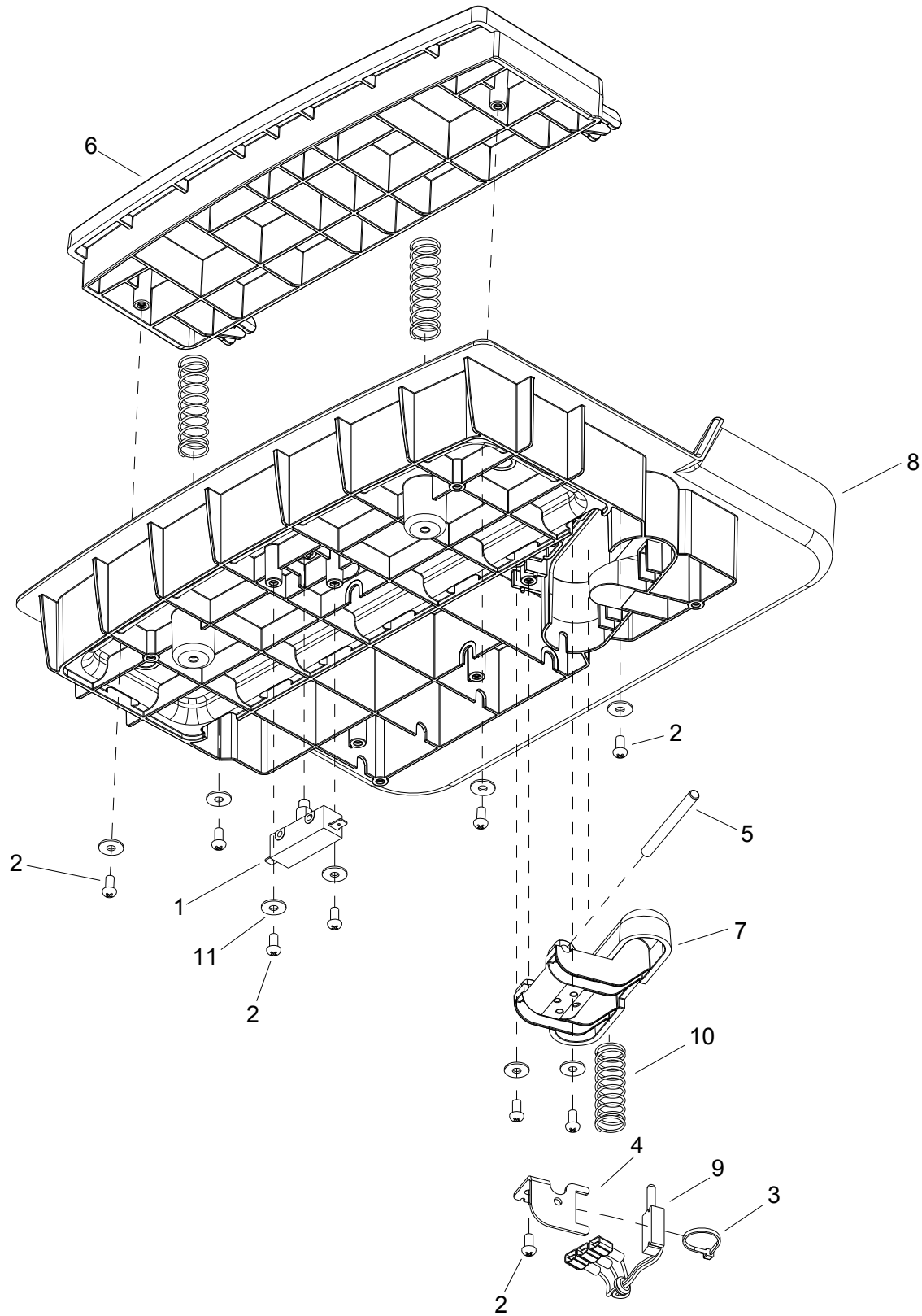

REF	PART NO.	QTY	DESCRIPTION	SERIAL NO. FROM	NOTES
1	86007110	1	SWITCH, 25A SPST 125-250V SNAP		
2	86172980	9	SCR, KA50X10, PT OHS, WN1412, PLTD		
3	86264930	1	CABLE TIE, 3.5" UL/CS		
4	86326150	1	BRKT, LINEAR POT		
5	86326140	1	PIN, DOWEL .25 X 2.75, STEEL		
6	86318010	1	PEDAL, HEEL		
7	86318000	1	PEDAL, ACCELERATOR		
8	86317990	1	PLATFORM, OPERATOR		
9	86311560	1	POTENTIOMETER ASM, LINEAR		
10	86254970	3	SPRING, COMP 18MM OD X 83 X 2		
11	86173330	8	WASHER, M5, FLAT, ISO7093, SS		

Pedal Platform Mounting

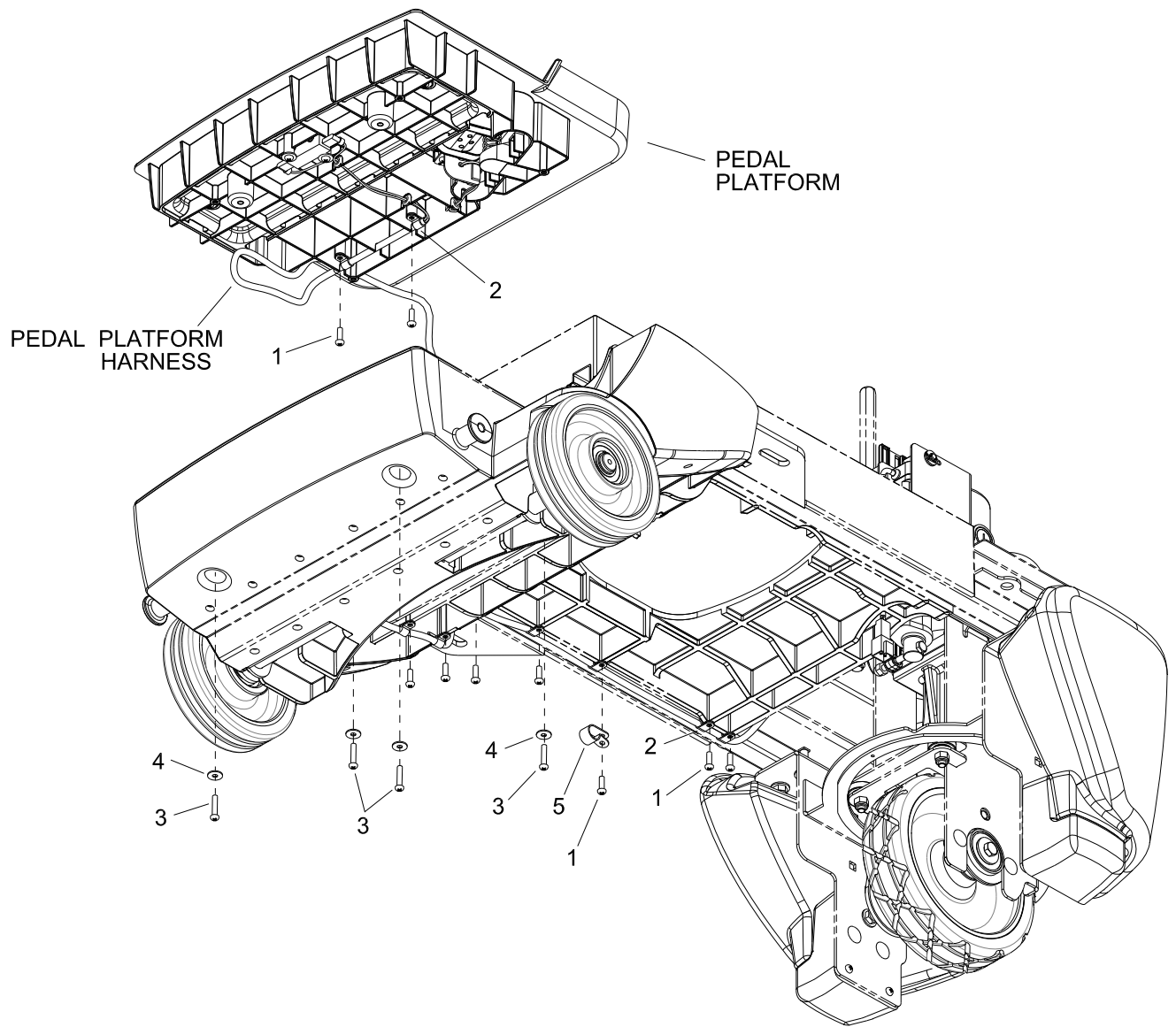

REF	PART NO.	QTY	DESCRIPTION	SERIAL NO. FROM	NOTES
1	86327510	9	SCR, KA50 X 16, WN1412 A2 SS		
2	86198440	9	CLAMP, 1/4 PLASTIC CABLE		
3	86327910	4	SCR, KA50X25, PT OHS, WN1412, PLTD		
4	86173330	4	WASHER, M5, FLAT, ISO7093, SS		
5	86198470	1	CLAMP, 9/16 DIA NYLON		

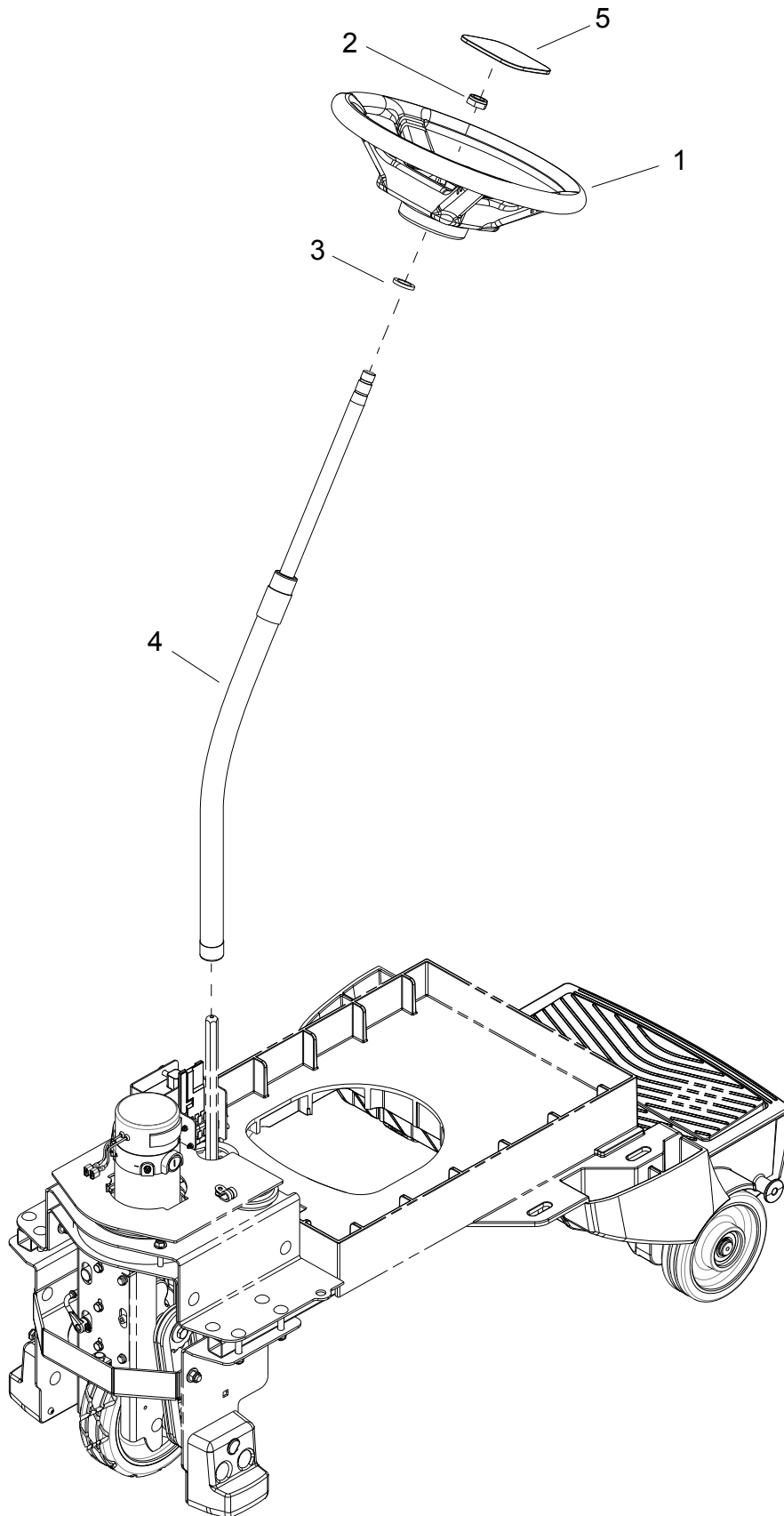

REF	PART NO.	QTY	DESCRIPTION	SERIAL NO. FROM	NOTES
1	86259610	1	WHEEL STEERING 40 SPLINE HUB		
2	86271610	1	NUT 5/8-18 HEX NYLOCK THN		
3	86279420	1	WASHER,.75IDX1.25ODX.125THK NY		
4	86378370	1	ASM, SHAFT, STEERING, CHARIOT 2		
5	86234810	1	COVER, STEERING WHEEL		

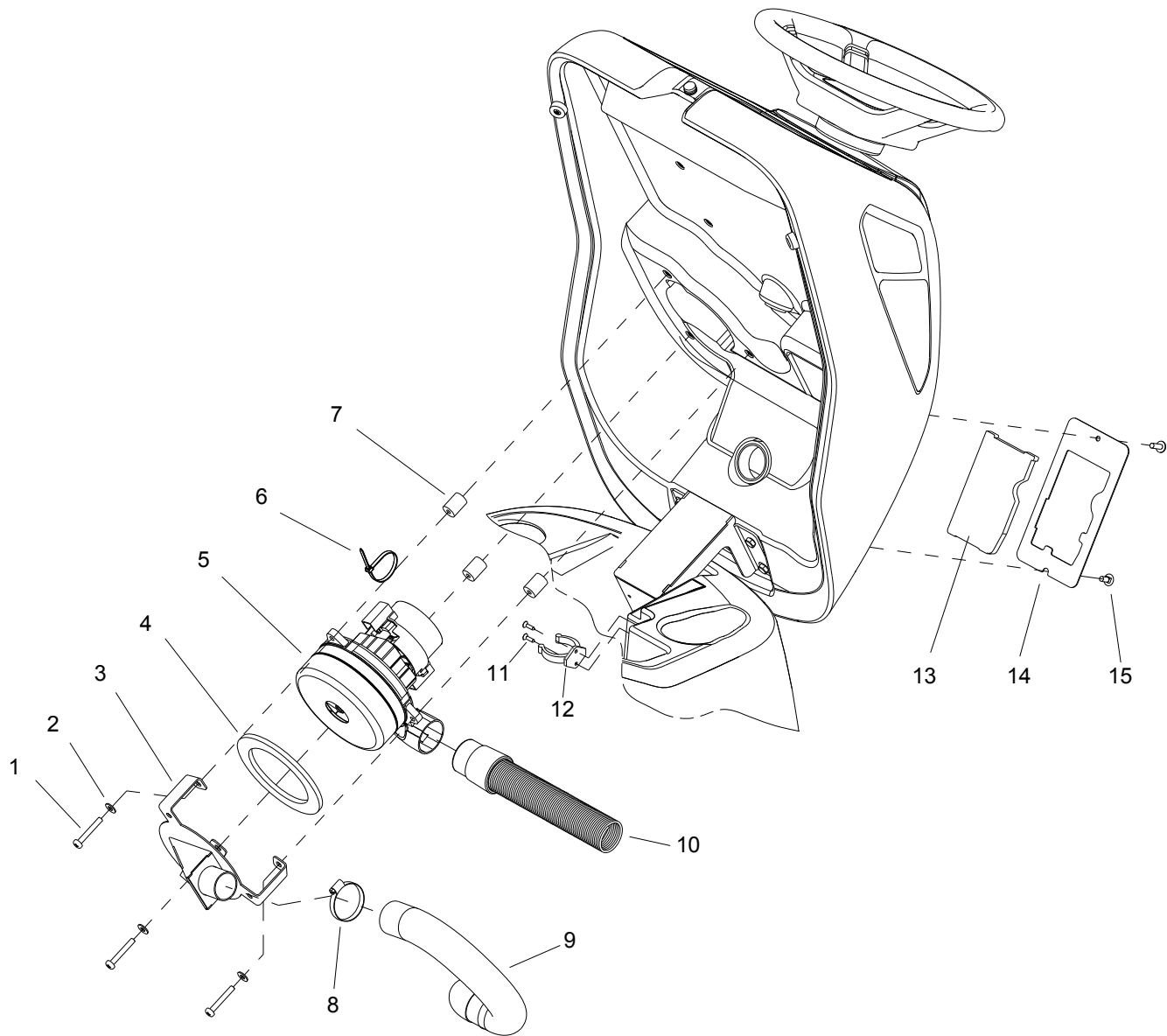

REF	PART NO.	QTY	DESCRIPTION	SERIAL NO. FROM	NOTES
1	86273920	3	SCREW 1/4-20 X 1.75 PPHMS SS		
2	86010630	3	WASHER 1/4 ID X 5/8 OD SS		
3	86353290	1	BRKT, VAC MOTOR		
4	86312920	1	GASKET, VAC MOTOR		
5	86012210	1	VAC MOTOR, 36VDC 2ST TD		
6	86264940	1	CABLE TIE, 11.38" UL/CSA		
7	86327500	3	MOUNT, VIBRATION		
8	86002400	1	CLAMP, 2.0" WORM GEAR X .312W		
9	86320330	1	HOSE ASM, 1.5 BLK VAC X12		
10	86356150	1	HOSE, 1.5" X 7.75", 4:1 STRETCH		
11	86291220	2	SCR, KA40X16,PT FLAT,WN1413,SS		
12	86355910	1	CLIP, 1-3/4", PLASTIC		
13	86143330	1	MOTOR FILTER U19836		
14	86354650	1	FRAME, FILTER		
15	86277640	2	SCREW 1/4-20 X 3/4 PTHMS SS		

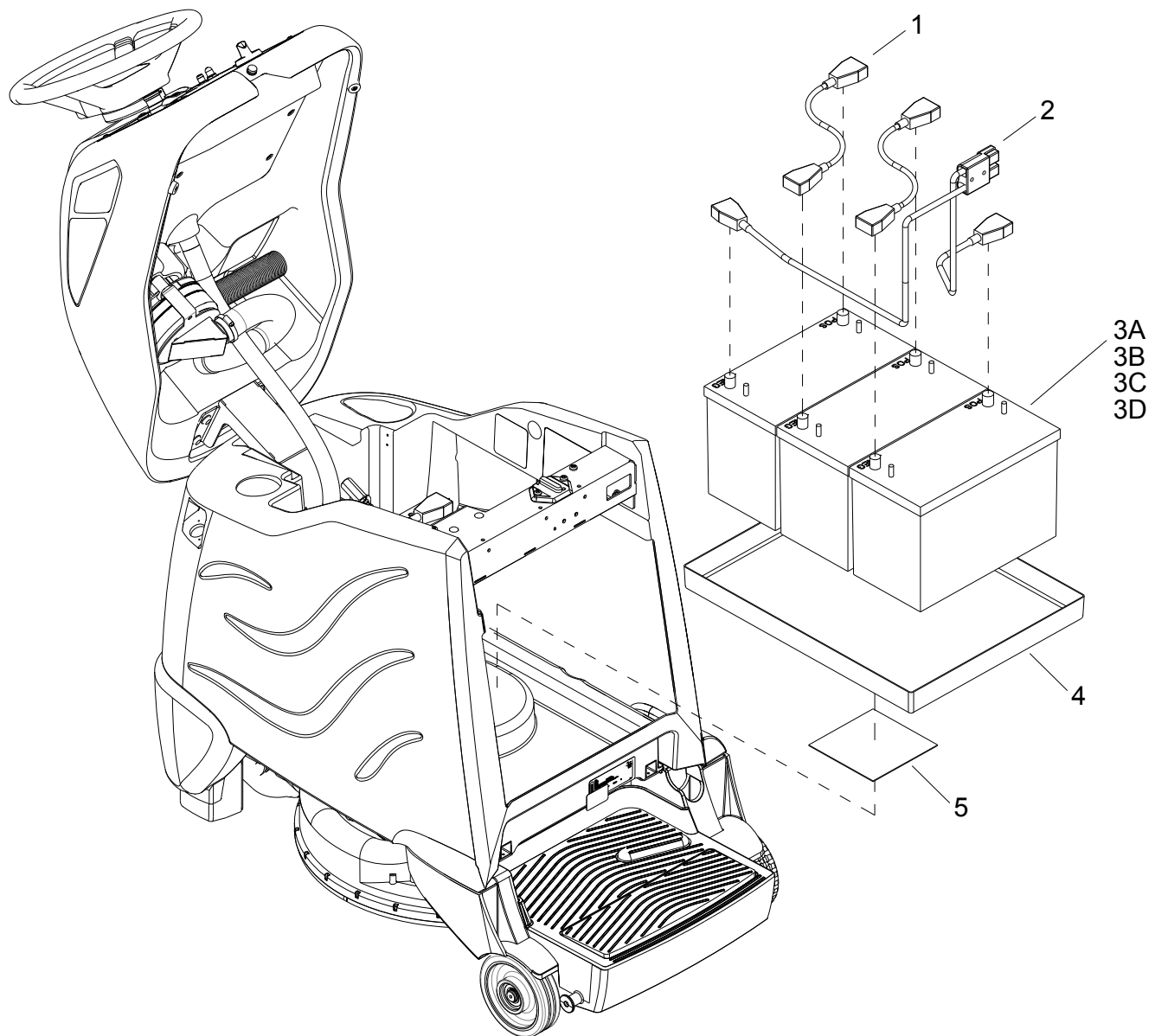

REF	PART NO.	QTY	DESCRIPTION	SERIAL NO. FROM	NOTES
1	86329720	2	BATT, CBL, ASM, JUMPER		
2	86356120	1	CABLE, ASM, BATTERY		
3A	86228400	3	BATTERY, 12V, 130AH		
3B	86328630	3	BATTERY, 12V 114A/H AGM		NOT SHOWN
3C	86283410	3	BATTERY, 12V, 225AH (J185H-AC)		NOT SHOWN
3D	86228430	3	BATTERY, 12V AGM 234AH		NOT SHOWN
4	86008300	1	TRAY, BATTERY LINER		REQD. WITH 86283410 & 86228430
5	86359550	1	TAPE, 1/16" T X 6.0" SQ. 2 SIDE ADH		

Wiring Diagram 1

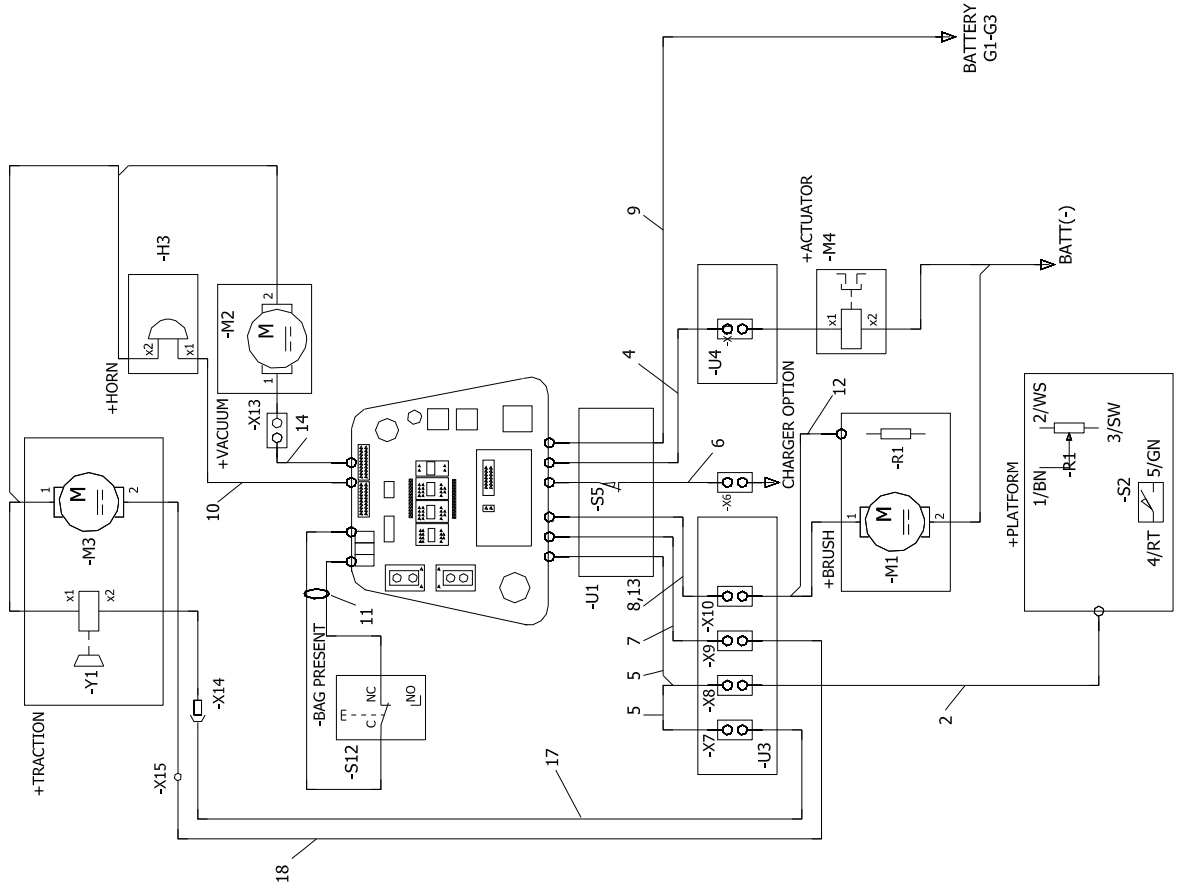

X7	BRAKE Y1		1 - 15/RT 2 - 14/SW
X8	POT PLATFORM U2		1 - 19/BN 2 - 20/WS 3 - 18/OR 4 - 17/GN 5 - 16/BL 6 - NC
X9	TRACTION M3		1 - 21/RT 2 - 22/SW
X10	BRUSH SHUNT M1		1 - 1/WS 2 - 2/SW 3 - 7/RT 4 - 13/GN
X11	ACTUATOR M4		1 - 3/RT 2 - 4/WS
X13	VACUUM M2		1 - 23/WS 2 - 24/SW
U1	INTERLOCK S5		1 - 11/SW 2 - 12/RT
X3	HORN H3	PANEL TB	5 - 5/WS 6 - 6/SW
X6	CHARGER OPTION		1 - 11C/SW 2 - 12C/RT

REF	PART NO.	QTY	DESCRIPTION	SERIAL NO. FROM	NOTES
1	86354410	1	HARNESS, PANEL IGLOSS20		
2	86356360	1	HARNESS, IGLOSS20 OPERATOR PLATFORM		
3	86354380	1	HARNESS, ROTARY SWITCH		
4	86344450		HARNESS, MAIN ACTUATOR		
5	86356350	1	HARNESS, IGLOSS20 MAIN POT AND BRAKE		
6	86356370	1	HARNESS, IGLOSS20 MAIN CHARGER		
7	86356340	1	HARNESS, IGLOSS20 MAIN TRACTION		
8	86354390	1	HARNESS, IGLOSS20 BRUSH		
9	86354400	1	HARNESS, IGLOSS20 MAIN POWER		
10	86333170	1	HARNESS, CS20 MAIN HORN		
11	86354370	1	HARNESS, IGLOSS20 BAG PRESENT		
12	86359290	1	HARNESS, IGLOSS20 SHUNT SENSE JUMPER		
13	86359300	1	HARNESS, IGLOSS20 SHUNT SENSE		
14	86333140		HARNESS, CS20 MAIN VACUUM		OPTIONAL
15	86359190	1	HARNESS, SHUNT JUMPER WIRE, BRAIDED		
16	86359200	1	HARNESS, SHUNT JUMPER WIRE		
17	86362990	1	HARNESS, LOWER BRAKE		
18	86365410	1	HARNESS, LOWER TRACTION		

Wiring Diagram 2

2

3

4

5

6

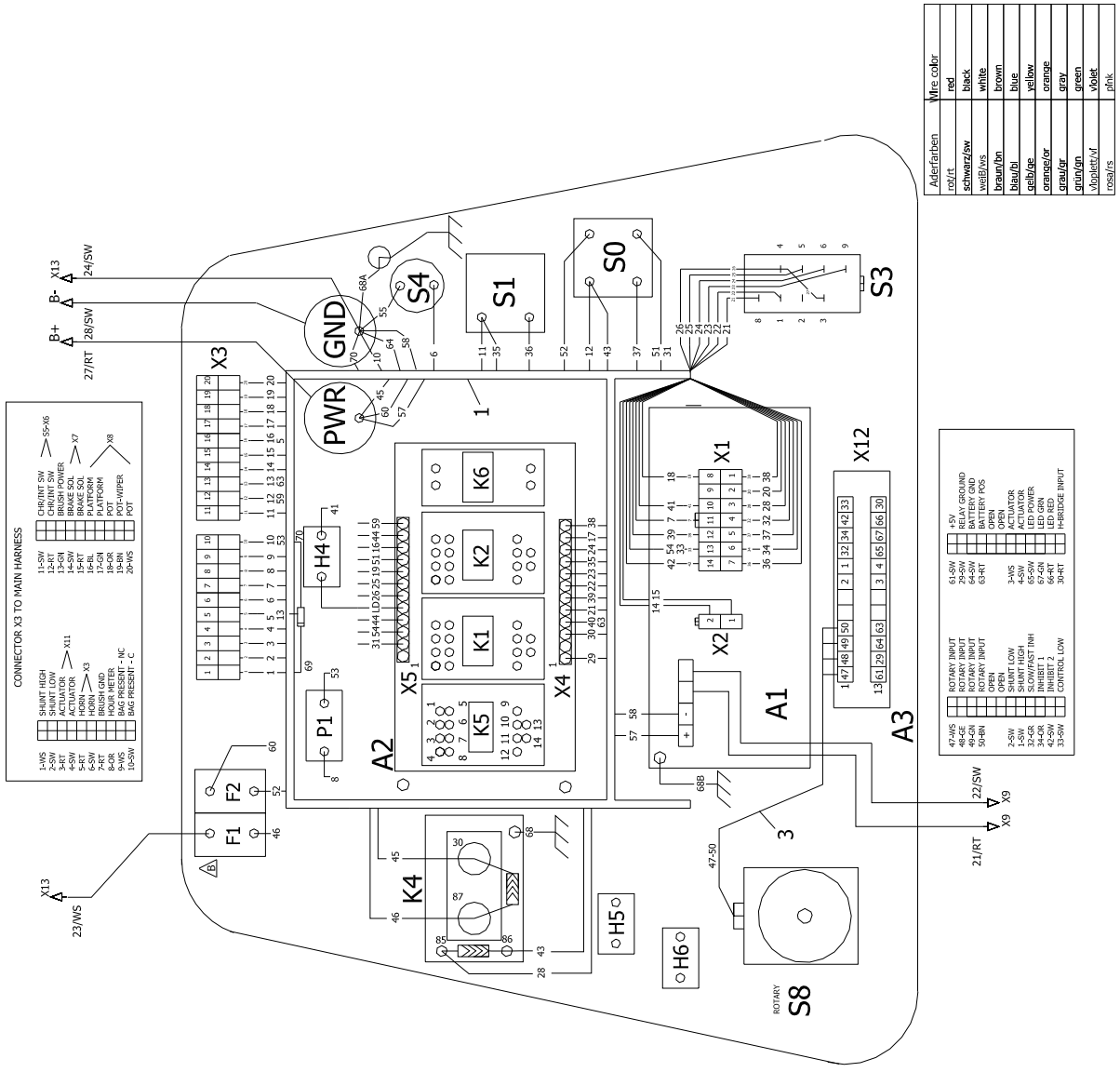

REF	PART NO.	QTY	DESCRIPTION	SERIAL NO. FROM	NOTES
1	86352310	1	HARNESS, I-DRIVE GND		

REF	DESCRIPTION
A1	DRIVE CONTROL
A2	RELAY BOARD
A3	PROCESSOR
F1	CIRCUIT BREAKER-DRIVE CONTROL
F2	CIRCUIT BREAKER-VACUUM MOTOR - OPTIONAL
F3	CIRCUIT BREAKER-BRUSH
G1-G3	BATTERY 12V
H1	SIGNAL LAMPS REVERSE DIRECTION
H2	SIGNAL LAMPS DIRECTION FORWARD
H3	HORN
H4	LED-BATT.
H5	LED
H6	LED
K1	RELAYS-REVERSE DIRECTION
K2	RELAYS DIRECTION FORWARD
K3	RELAYS BRUSH MOTOR
K4	RELAY VACUUM MOTOR - OPTIONAL
K5	RELAYS ACTUATOR
K6	RELAYS MAIN
M1	BRUSH MOTOR
M2	VACUUM MOTOR - OPTIONAL
M3	TRACTION MOTOR
M4	LINEAR ACTUATOR MOTOR BRUSH / SQUEEGEE
S0	EMERGENCY SWITCH
S1	KEYSWITCH
S2	MICROSWITCH-PLATFORM
S3	BUTTON REVERSE FORWARD
S4	HORN BUTTON
S5	MICROSWITCH-COVER
S8	PROGRAM SWITCH
S11	CHARGER
S12	BAG PRESENT
R1	SHUNT
P1	HOURS METER
V1-V2-V3-V4-V5-V6-V7-V8-V9-V10-V11-V12	DIODE
V-UP & V-DOWN	DIODE-MOTOR M4
X3	TERMINAL BLOCK
X12	TERMINAL BLOCK
** X6-X7-X8-X11	DEUTSCH CONNECTOR
* X9-X10-X13	PACKARD CONNECTOR
X14	FASTON TERMINAL
X15	RING TERMINAL
Y1	BRAKE

Wiring Diagram 3

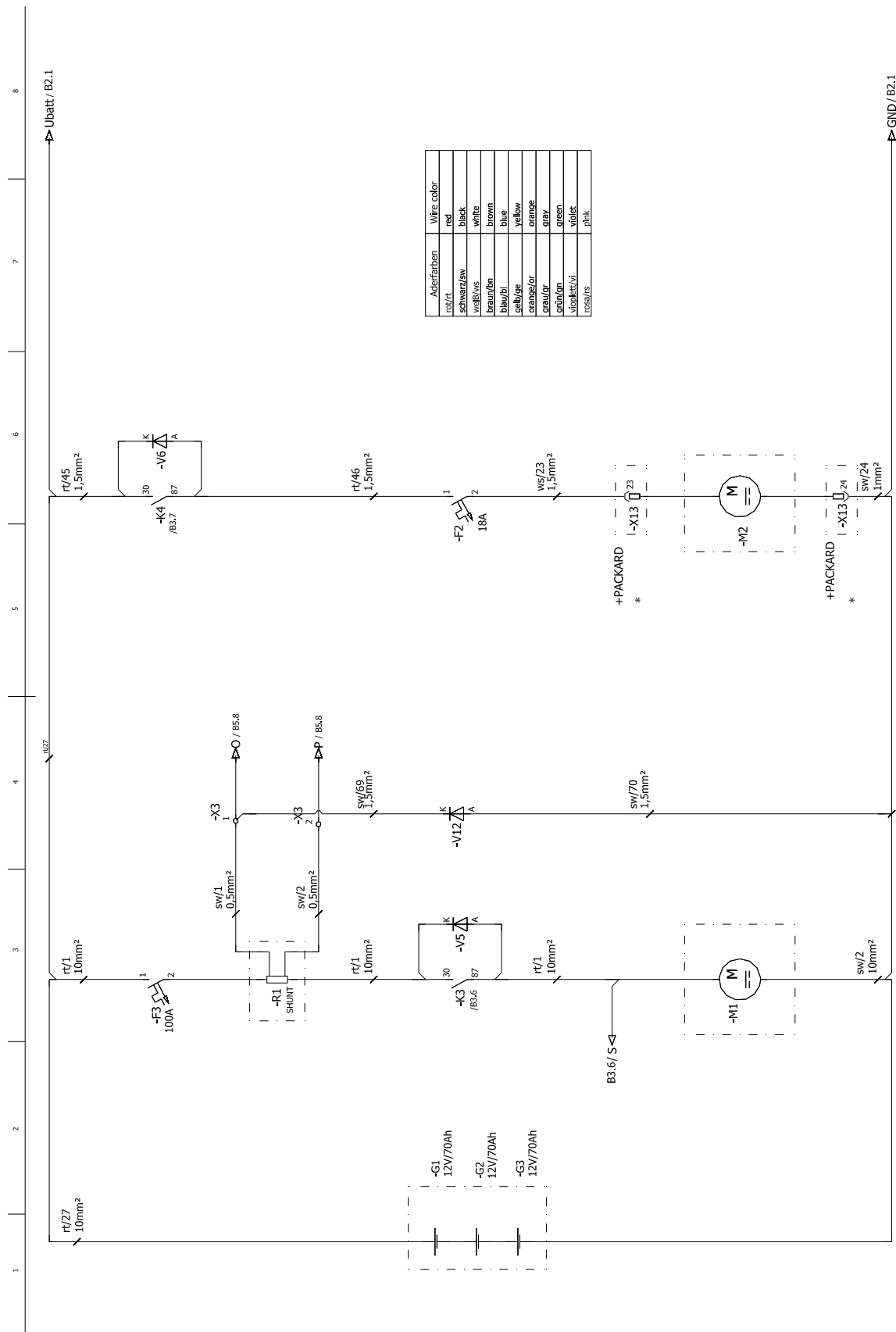

REF	DESCRIPTION
A1	DRIVE CONTROL
A2	RELAY BOARD
A3	PROCESSOR
F1	CIRCUIT BREAKER-DRIVE CONTROL
F2	CIRCUIT BREAKER-VACUUM MOTOR - OPTIONAL
F3	CIRCUIT BREAKER-BRUSH
G1-G3	BATTERY 12V
H1	SIGNAL LAMPS REVERSE DIRECTION
H2	SIGNAL LAMPS DIRECTION FORWARD
H3	HORN
H4	LED-BATT.
H5	LED
H6	LED
K1	RELAYS-REVERSE DIRECTION
K2	RELAYS DIRECTION FORWARD
K3	RELAYS BRUSH MOTOR
K4	RELAY VACUUM MOTOR - OPTIONAL
K5	RELAYS ACTUATOR
K6	RELAYS MAIN
M1	BRUSH MOTOR
M2	VACUUM MOTOR - OPTIONAL
M3	TRACTION MOTOR
M4	LINEAR ACTUATOR MOTOR BRUSH / SQUEEGEE
S0	EMERGENCY SWITCH
S1	KEYSWITCH
S2	MICROSWITCH-PLATFORM
S3	BUTTON REVERSE FORWARD
S4	HORN BUTTON
S5	MICROSWITCH-COVER
S8	PROGRAM SWITCH
S11	CHARGER
S12	BAG PRESENT
R1	SHUNT
P1	HOURS METER
V1-V2-V3-V4-V5-V6-V7-V8-V9-V10-V11-V12	DIODE
V-UP & V-DOWN	DIODE-MOTOR M4
X3	TERMINAL BLOCK
X12	TERMINAL BLOCK
** X6-X7-X8-X11	DEUTSCH CONNECTOR
* X9-X10-X13	PACKARD CONNECTOR
X14	FASTON TERMINAL
X15	RING TERMINAL
Y1	BRAKE

Wiring Diagram 4

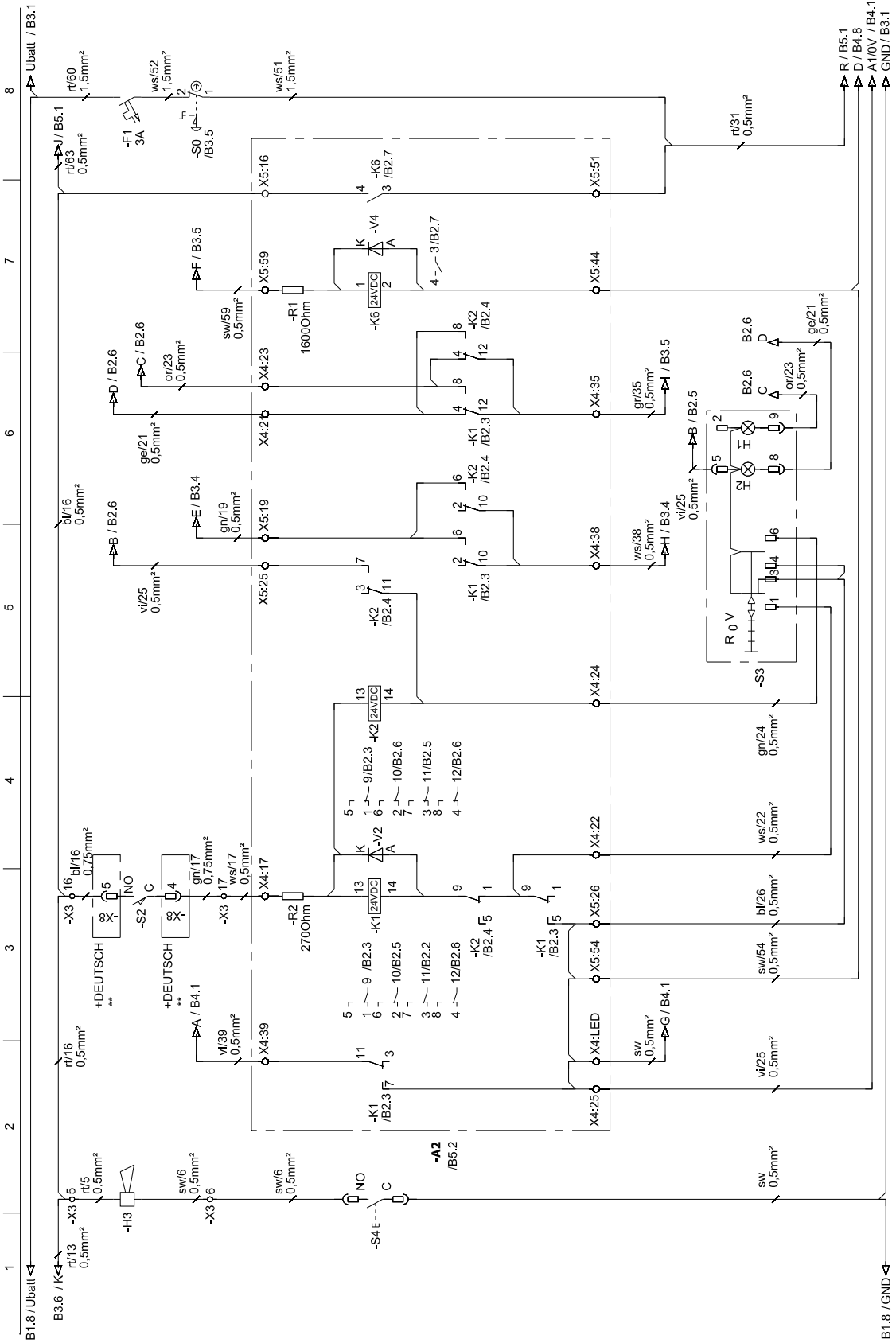

REF	DESCRIPTION
A1	DRIVE CONTROL
A2	RELAY BOARD
A3	PROCESSOR
F1	CIRCUIT BREAKER-DRIVE CONTROL
F2	CIRCUIT BREAKER-VACUUM MOTOR - OPTIONAL
F3	CIRCUIT BREAKER-BRUSH
G1-G3	BATTERY 12V
H1	SIGNAL LAMPS REVERSE DIRECTION
H2	SIGNAL LAMPS DIRECTION FORWARD
H3	HORN
H4	LED-BATT.
H5	LED
H6	LED
K1	RELAYS-REVERSE DIRECTION
K2	RELAYS DIRECTION FORWARD
K3	RELAYS BRUSH MOTOR
K4	RELAY VACUUM MOTOR - OPTIONAL
K5	RELAYS ACTUATOR
K6	RELAYS MAIN
M1	BRUSH MOTOR
M2	VACUUM MOTOR - OPTIONAL
M3	TRACTION MOTOR
M4	LINEAR ACTUATOR MOTOR BRUSH / SQUEEGEE
S0	EMERGENCY SWITCH
S1	KEYSWITCH
S2	MICROSWITCH-PLATFORM
S3	BUTTON REVERSE FORWARD
S4	HORN BUTTON
S5	MICROSWITCH-COVER
S8	PROGRAM SWITCH
S11	CHARGER
S12	BAG PRESENT
R1	SHUNT
P1	HOURS METER
V1-V2-V3-V4-V5-V6- V7-V8-V9-V10-V11- V12	DIODE
V-UP & V-DOWN	DIODE-MOTOR M4
X3	TERMINAL BLOCK
X12	TERMINAL BLOCK
** X6-X7-X8-X11	DEUTSCH CONNECTOR
* X9-X10-X13	PACKARD CONNECTOR
X14	FASTON TERMINAL
X15	RING TERMINAL
Y1	BRAKE

Wiring Diagram 5

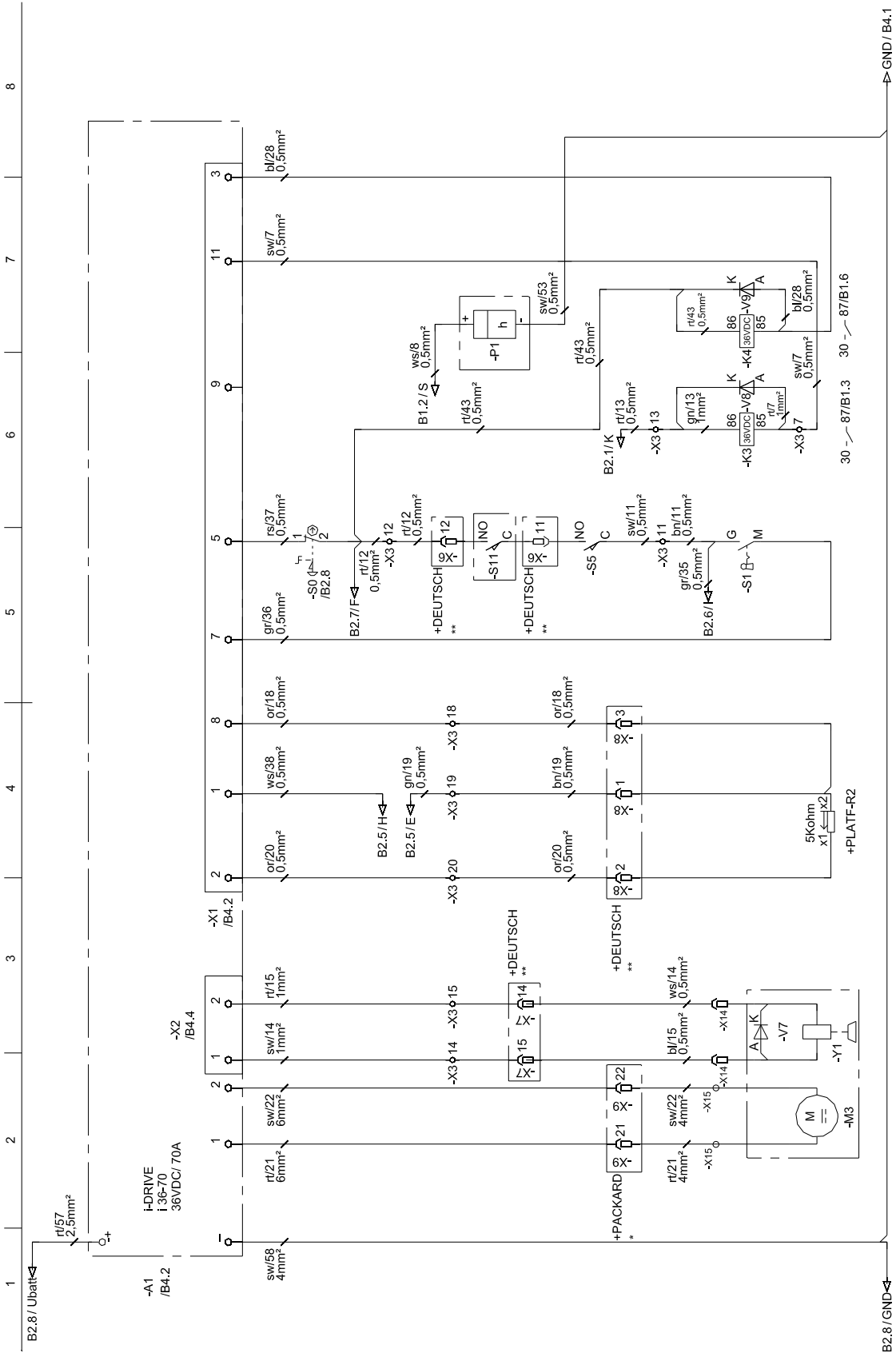

REF	DESCRIPTION
A1	DRIVE CONTROL
A2	RELAY BOARD
A3	PROCESSOR
F1	CIRCUIT BREAKER-DRIVE CONTROL
F2	CIRCUIT BREAKER-VACUUM MOTOR - OPTIONAL
F3	CIRCUIT BREAKER-BRUSH
G1-G3	BATTERY 12V
H1	SIGNAL LAMPS REVERSE DIRECTION
H2	SIGNAL LAMPS DIRECTION FORWARD
H3	HORN
H4	LED-BATT.
H5	LED
H6	LED
K1	RELAYS-REVERSE DIRECTION
K2	RELAYS DIRECTION FORWARD
K3	RELAYS BRUSH MOTOR
K4	RELAY VACUUM MOTOR - OPTIONAL
K5	RELAYS ACTUATOR
K6	RELAYS MAIN
M1	BRUSH MOTOR
M2	VACUUM MOTOR - OPTIONAL
M3	TRACTION MOTOR
M4	LINEAR ACTUATOR MOTOR BRUSH / SQUEEGEE
S0	EMERGENCY SWITCH
S1	KEYSWITCH
S2	MICROSWITCH-PLATFORM
S3	BUTTON REVERSE FORWARD
S4	HORN BUTTON
S5	MICROSWITCH-COVER
S8	PROGRAM SWITCH
S11	CHARGER
S12	BAG PRESENT
R1	SHUNT
P1	HOURS METER
V1-V2-V3-V4-V5-V6- V7-V8-V9-V10-V11- V12	DIODE
V-UP & V-DOWN	DIODE-MOTOR M4
X3	TERMINAL BLOCK
X12	TERMINAL BLOCK
** X6-X7-X8-X11	DEUTSCH CONNECTOR
* X9-X10-X13	PACKARD CONNECTOR
X14	FASTON TERMINAL
X15	RING TERMINAL
Y1	BRAKE

Wiring Diagram 6

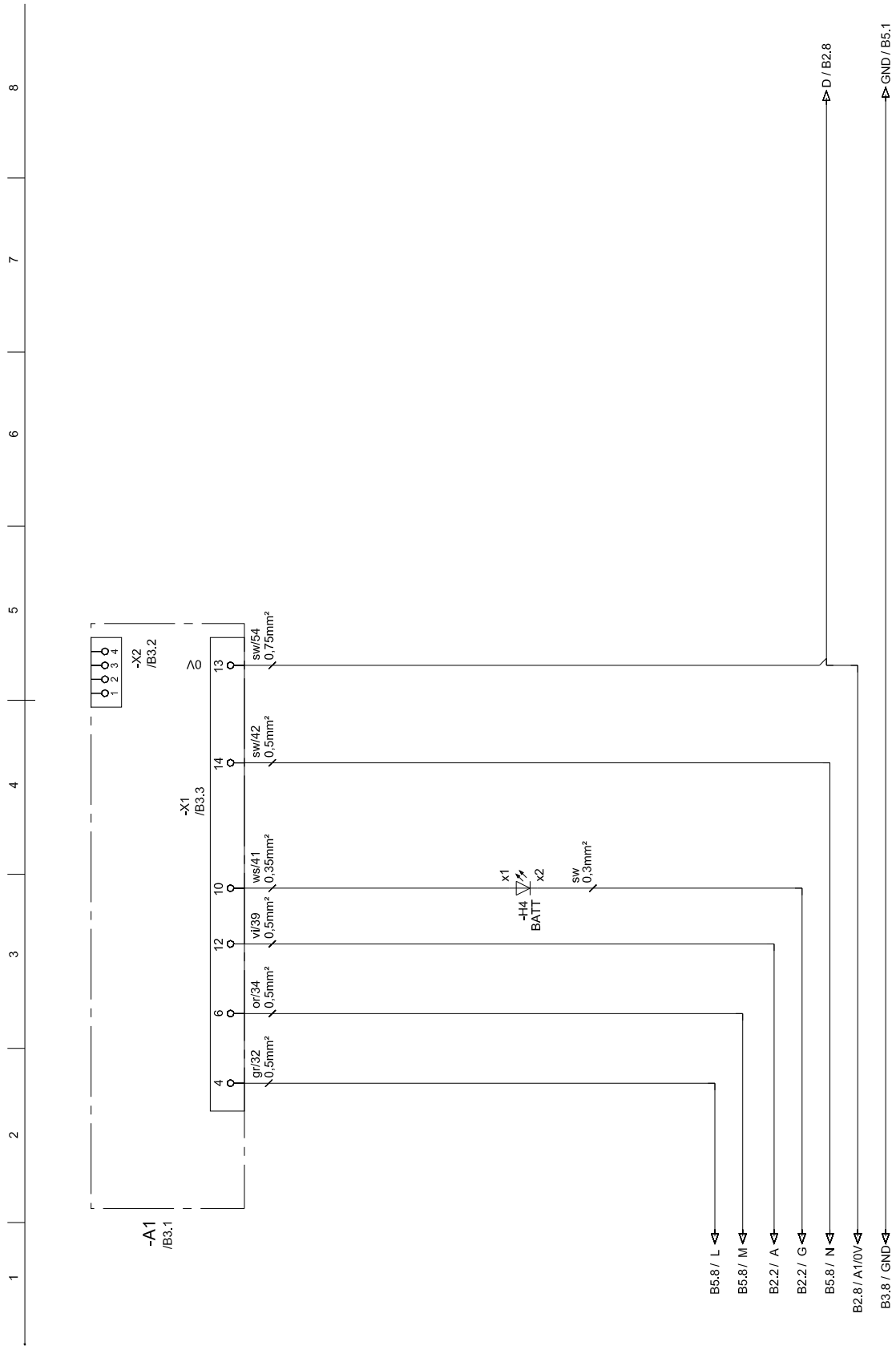

REF	DESCRIPTION
A1	DRIVE CONTROL
A2	RELAY BOARD
A3	PROCESSOR
F1	CIRCUIT BREAKER-DRIVE CONTROL
F2	CIRCUIT BREAKER-VACUUM MOTOR - OPTIONAL
F3	CIRCUIT BREAKER-BRUSH
G1-G3	BATTERY 12V
H1	SIGNAL LAMPS REVERSE DIRECTION
H2	SIGNAL LAMPS DIRECTION FORWARD
H3	HORN
H4	LED-BATT.
H5	LED
H6	LED
K1	RELAYS-REVERSE DIRECTION
K2	RELAYS DIRECTION FORWARD
K3	RELAYS BRUSH MOTOR
K4	RELAY VACUUM MOTOR - OPTIONAL
K5	RELAYS ACTUATOR
K6	RELAYS MAIN
M1	BRUSH MOTOR
M2	VACUUM MOTOR - OPTIONAL
M3	TRACTION MOTOR
M4	LINEAR ACTUATOR MOTOR BRUSH / SQUEEGEE
S0	EMERGENCY SWITCH
S1	KEYSWITCH
S2	MICROSWITCH-PLATFORM
S3	BUTTON REVERSE FORWARD
S4	HORN BUTTON
S5	MICROSWITCH-COVER
S8	PROGRAM SWITCH
S11	CHARGER
S12	BAG PRESENT
R1	SHUNT
P1	HOURS METER
V1-V2-V3-V4-V5-V6- V7-V8-V9-V10-V11- V12	DIODE
V-UP & V-DOWN	DIODE-MOTOR M4
X3	TERMINAL BLOCK
X12	TERMINAL BLOCK
** X6-X7-X8-X11	DEUTSCH CONNECTOR
* X9-X10-X13	PACKARD CONNECTOR
X14	FASTON TERMINAL
X15	RING TERMINAL
Y1	BRAKE

Wiring Diagram 7

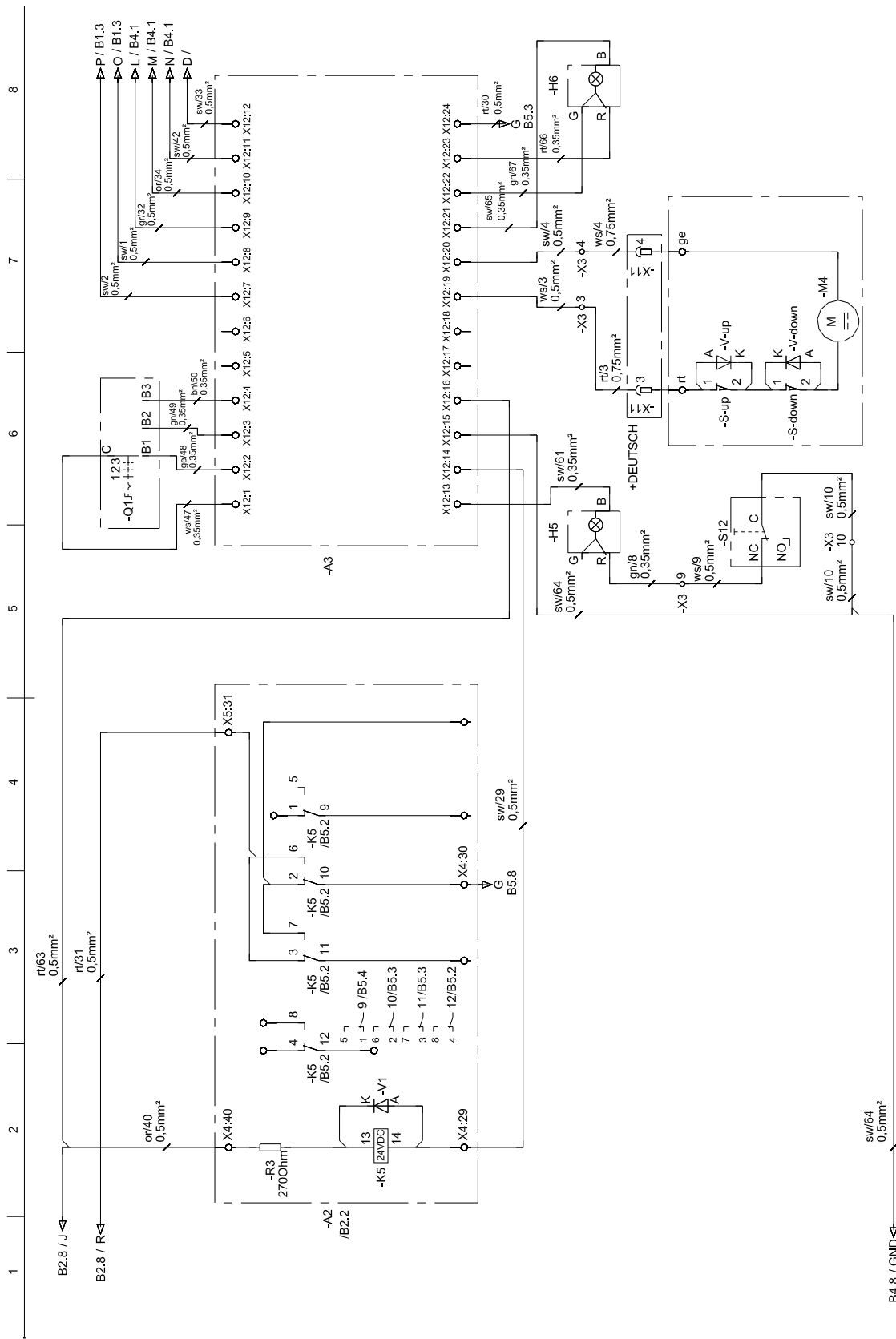

REF	DESCRIPTION
A1	DRIVE CONTROL
A2	RELAY BOARD
A3	PROCESSOR
F1	CIRCUIT BREAKER-DRIVE CONTROL
F2	CIRCUIT BREAKER-VACUUM MOTOR - OPTIONAL
F3	CIRCUIT BREAKER-BRUSH
G1-G3	BATTERY 12V
H1	SIGNAL LAMPS REVERSE DIRECTION
H2	SIGNAL LAMPS DIRECTION FORWARD
H3	HORN
H4	LED-BATT.
H5	LED
H6	LED
K1	RELAYS-REVERSE DIRECTION
K2	RELAYS DIRECTION FORWARD
K3	RELAYS BRUSH MOTOR
K4	RELAY VACUUM MOTOR - OPTIONAL
K5	RELAYS ACTUATOR
K6	RELAYS MAIN
M1	BRUSH MOTOR
M2	VACUUM MOTOR - OPTIONAL
M3	TRACTION MOTOR
M4	LINEAR ACTUATOR MOTOR BRUSH / SQUEEGEE
S0	EMERGENCY SWITCH
S1	KEYSWITCH
S2	MICROSWITCH-PLATFORM
S3	BUTTON REVERSE FORWARD
S4	HORN BUTTON
S5	MICROSWITCH-COVER
S8	PROGRAM SWITCH
S11	CHARGER
S12	BAG PRESENT
R1	SHUNT
P1	HOURS METER
V1-V2-V3-V4-V5-V6- V7-V8-V9-V10-V11- V12	DIODE
V-UP & V-DOWN	DIODE-MOTOR M4
X3	TERMINAL BLOCK
X12	TERMINAL BLOCK
** X6-X7-X8-X11	DEUTSCH CONNECTOR
* X9-X10-X13	PACKARD CONNECTOR
X14	FASTON TERMINAL
X15	RING TERMINAL
Y1	BRAKE

Wiring Diagram 8

FRONT

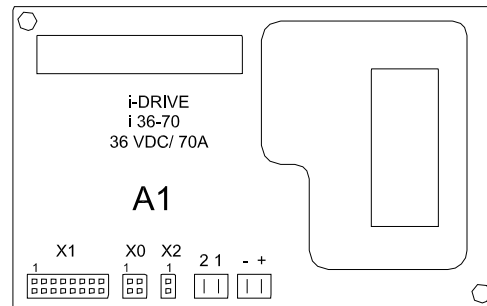
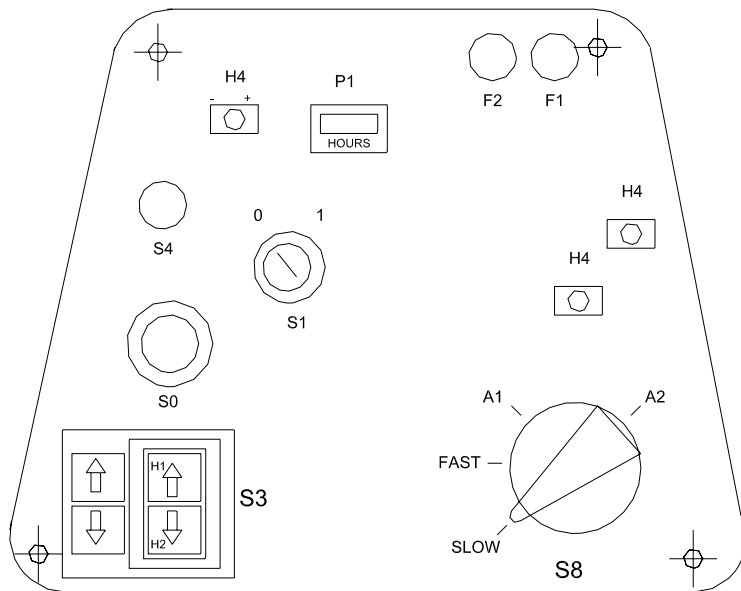

BACK

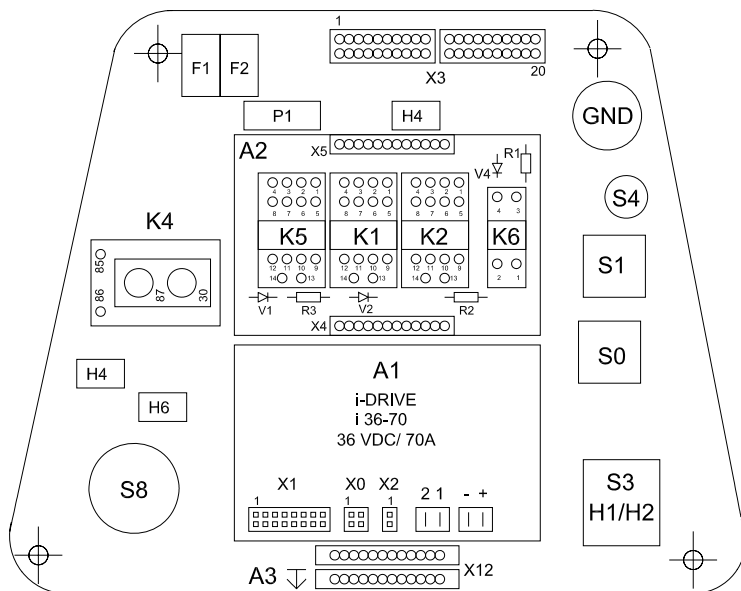

REF	DESCRIPTION
A1	DRIVE CONTROL
A2	RELAY BOARD
A3	PROCESSOR
F1	CIRCUIT BREAKER-DRIVE CONTROL
F2	CIRCUIT BREAKER-VACUUM MOTOR - OPTIONAL
F3	CIRCUIT BREAKER-BRUSH
G1-G3	BATTERY 12V
H1	SIGNAL LAMPS REVERSE DIRECTION
H2	SIGNAL LAMPS DIRECTION FORWARD
H3	HORN
H4	LED-BATT.
H5	LED
H6	LED
K1	RELAYS-REVERSE DIRECTION
K2	RELAYS DIRECTION FORWARD
K3	RELAYS BRUSH MOTOR
K4	RELAY VACUUM MOTOR - OPTIONAL
K5	RELAYS ACTUATOR
K6	RELAYS MAIN
M1	BRUSH MOTOR
M2	VACUUM MOTOR - OPTIONAL
M3	TRACTION MOTOR
M4	LINEAR ACTUATOR MOTOR BRUSH / SQUEEGEE
S0	EMERGENCY SWITCH
S1	KEYSWITCH
S2	MICROSWITCH-PLATFORM
S3	BUTTON REVERSE FORWARD
S4	HORN BUTTON
S5	MICROSWITCH-COVER
S8	PROGRAM SWITCH
S11	CHARGER
S12	BAG PRESENT
R1	SHUNT
P1	HOURS METER
V1-V2-V3-V4-V5-V6- V7-V8-V9-V10-V11- V12	DIODE
V-UP & V-DOWN	DIODE-MOTOR M4
X3	TERMINAL BLOCK
X12	TERMINAL BLOCK
** X6-X7-X8-X11	DEUTSCH CONNECTOR
* X9-X10-X13	PACKARD CONNECTOR
X14	FASTON TERMINAL
X15	RING TERMINAL
Y1	BRAKE

Suggested Spare Parts

PART NO.	DESCRIPTION	SERIAL NO. FROM	NOTES
86001030	BEARING, BALL 3/4 BORE SPHERED		
86228990	BEARING,FLNGD,.314ID X.502OD		
86001260	BOOT, CB 3/8-32 UN		
86332510	BOOT, SEAL PUSH BUTTON 11MM		
86008920	BOOT, RUBBER TERM. ISOLATOR		
86340030	BREAKER, 100A CIRCUIT		
86353680	BREAKER, 1.5A, CARLING MAGNETIC		
86316160	BREAKER, 18A, 250VAC, 32VDC		
86353780	BRUSH, FLEXIBLE STRIP, 72" LONG		
86348010	BRUSH SET, BURNISHER MOTOR		
86135310	BRUSH SET, 24/36V VAC, WINDSOR		
86232780	CHAIN MASTERLINK 12.7MM		
86284790	FILTER BAG (10 PACK)		
86327830	GASKET,.188X.31X41.0		
86354630	GASKET, BAG MOUNT		
86353660	GASKET, BAG COVER, 43.6"		
86312920	GASKET, VAC MOTOR		
53217380	KNOB, SELECTION		
86328860	NUT, 5/16 PUSH-LOCK, PLTD		
86143330	MOTOR FILTER U19836		
86223470	RING, 20MM EXTERNAL SNAP		
86007910	SPRING EXT .31D X 2.0L X .03W		
86327680	SWITCH, INTERLOCK		
86007170	SWITCH, KEY 2 POSITION		
86313950	SWITCH, SPDT 3 POSN MOM, ARROW		
86354640	WASHER, 1.5ID SINK, RUBBER		
86318020	WHEEL, PU 150MM X 40MM		
86316890	WHEEL, PU 200MM X 50MM		

REF. NO	MODEL: SERIAL #
1	10020350000012, 10020360000016
2	10020350000012, 10020360000013
3	10020350000014, 10020360000017
4	10020310000033, 10020320000009, 10020330000036, 10020340000007, 10020350000060, 10020360000075
5	10020310000068, 10020320000015, 10020330000040, 10020340000010, 10020350000064, 10020360000079
6	10020310000018, 10020320000021, 10020330000043, 10020340000014, 10020350000083, 10020360100101
7	10020310000079, 10020320000019, 10020330000043, 10020340000014, 10020350000072, 10020360100093
8	10020310000103, 10020320000030, 10020330000053, 10020340000024, 10020350000097, 10020360100137
9	10020310000124, 10020320000054, 10020330000063, 10020340000032, 10020350000132, 10020360100199
10	10020310000177, 10020320000095, 10020330000083, 10020340000053, 10020350000188, 10020360100300