

PARTS LIST
MUSTANG FLOOR MACHINE

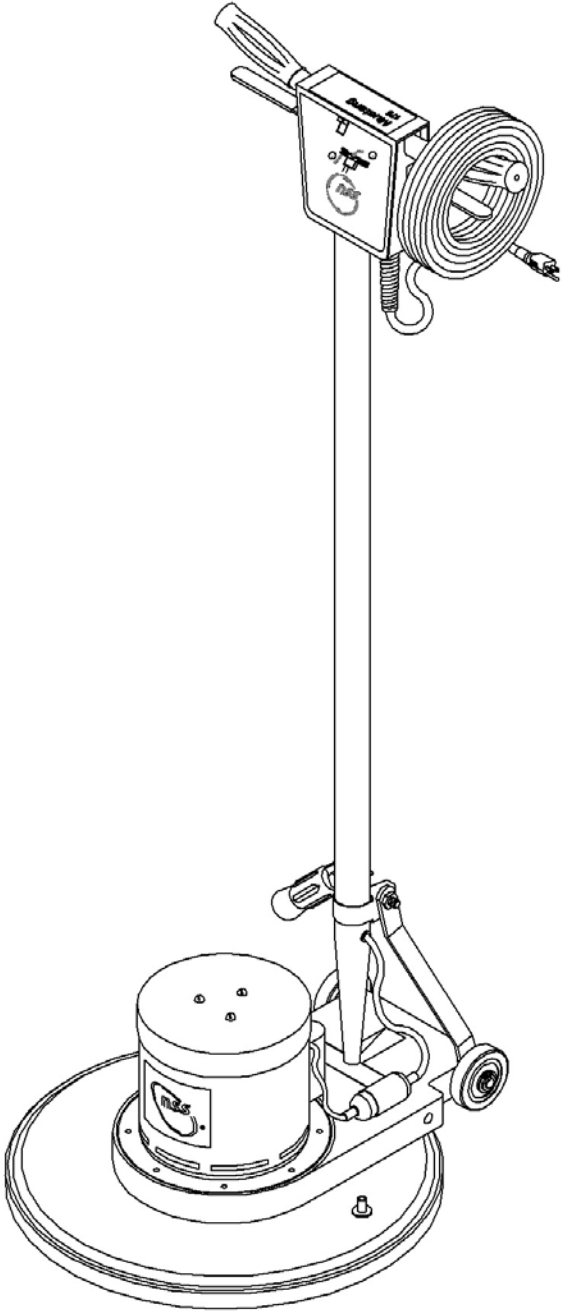

HANDLE ASSEMBLY

ITEM	PART NO.	DESCRIPTION	QTY
101	5392411	LABEL - "SWITCH BOX"	1
102	0393511	LOCKOUT BRACKET	1
103	0393521	LOCK OUT	1
104	0393411	GRIP - SWITCH LEVER	2
105	9120828	1/8 X 1 3/4 ROLL PIN - PACK OF 4	2
106	5390171	SWITCH LEVER SPRING	2
107	5092331	FLAG TERMINAL - CRIMP ON	1
108	5391321	WIRE NUT - ORANGE - 120 VOLT ONLY	1
109	0393401	SWITCH LEVER	1
110	9120100	#6-32 X 1 ROUND HEAD PHILLIPS MACHINE SCREW - PACK OF 10	2
111	9120130	#6 EXTERNAL STAR LOCK WASHER - PACK OF 10	2
112	5390211	SWITCH	1
113	5390361	SWITCH INSULATOR	1
114	9120380	#10-24 X 3/8 ROUND HEAD PHILLIPS MACHINE SCREW - PACK OF 10	1
115	9120320	#10 SPLIT LOCK WASHER - PACK OF 10	1
116	0298981	#10 RING TERMINAL 14-16 AWG	1
117	5092511	PLUG BUTTON - MUSTANG FLOOR MACHINES ONLY	1
121	5391891	HANDLE	1
122	5390511	FOAM PAD	1
123	5090441	NYLON BUSHING	2
124	5293131	GROMMET	1
125	0393631	PLUG/CORD COVER – HANDLE	1
126	5490861	HANDLE CORD	1
127	5091561	CORD 50 FEET 14-3 - 120 VOLT ONLY	1
	0299671	SHUKO CORD - 75 FEET - 16-3 - 240 VOLT ONLY	1
128	9120080	#6-32 X 3/4 ROUND HEAD PHILLIPS MACHINE SCREW - 240 V ONLY - PK-10	1
129	5391931	TERMINAL BLOCK - 240 VOLT ONLY	1
130	5391921	WIRE - GROUND - 240 VOLT ONLY	1
131	5391911	WIRE - DEAD MAN - 240 VOLT ONLY	1
132	5091671	STRAIN RELIEF - 120 VOLT ONLY	1
	0299531	STRAIN RELIEF - 240 VOLT ONLY	1
133	5390261	STRAIN RELIEF NUT - 120 VOLT ONLY	3
	0891131	STRAIN RELIEF NUT - 240 VOLT ONLY	1
134	5092371	STRAIN RELIEF CORD CLAMP - 120 VOLT ONLY	1
	0299661	STRAIN RELIEF CORD CLAMP - 240 VOLT ONLY	1
135	9123240	9/16 I.D. X 1 1/2 FLAT WASHER – PACK OF 2	1
136	5095501	CORD CLAMP	1
137	8791070	VINYL HOSE	1
138	9120025	#6-32 DOUBLE HOLE SWITCH SPEED NUT - PACK OF 1	1
139	0393441	HANDLE GRIP	2
140	9120320	#10 SPLIT LOCK WASHER - PACK OF 10	1
141	9120380	#10-24 X 3/8 ROUND HEAD PHILLIPS MACHINE SCREW - PACK OF 10	1
142	0393381	SPRING	1
143	0393881	M3 X .05 X 8mm PAN HEAD PHILLIPS THREAD CUTTING SCREW	2
144	0393841	M3 EXTERNAL STAR LOCK WASHER	2
145	9120320	#10 SPLIT LOCK WASHER - PACK OF 10	1
146	9120430	#10-24 X 3/4 ROUND HEAD PHILLIPS MACHINE SCREW – PACK OF 10	1
147	0190681	WARNING LABEL	1
148	5391873	SWITCH BOX COVER	1
149	5991411	IDENTIFIER LABEL – MUSTANG FLOOR MACHINE	1

HANDLE ASSEMBLY

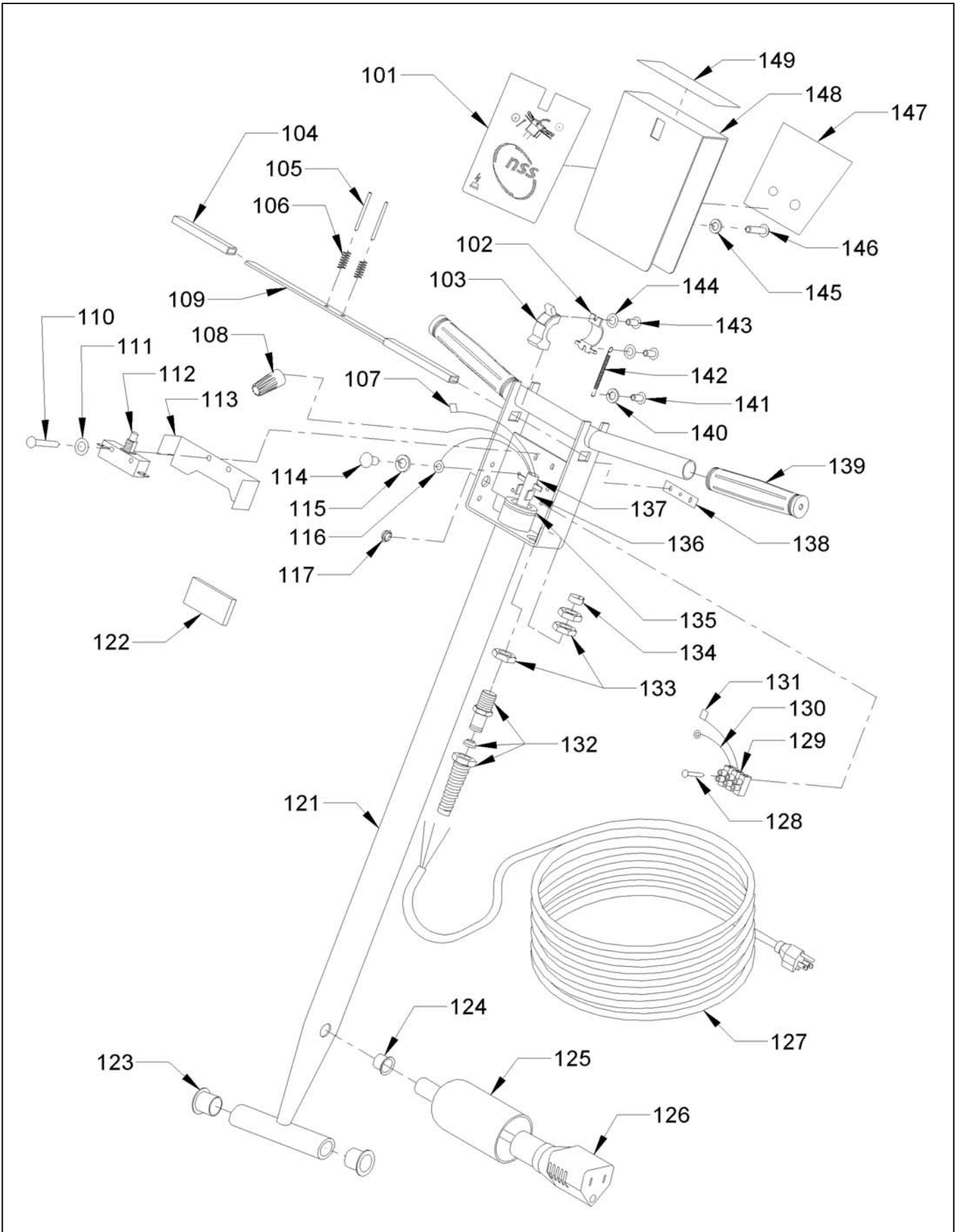

BASE ASSEMBLY

<u>ITEM</u>	<u>PART NO.</u>	<u>DESCRIPTION</u>	<u>QTY</u>
201	9120750	#10-32 X 1/2 TRUSS HEAD PHILLIPS MACHINE SCREW - PACK OF 10	3
202	5094991	MOTOR COVER	1
203	5095011	1HP MOTOR 120 VOLT 60 HZ 11:1 2P GEAR BOX	1
	5095411	1HP MOTOR 120V60HZ W/CORD,PLUG COVER,END SHIELD -NO GEAR BOX	1
203	5095079	1HP MOTOR 240 VOLT 60 HZ 11:1 2P GEAR BOX – REWIRE	1
	5095479	1HP MOTOR120V60HZ W/END SHIELD W/OUT GEAR BOX REWIRE	1
203	5095021	1HP MOTOR 240 VOLT 50 HZ 11:1 2P GEAR BOX	1
	5095421	1HP MOTOR 240V50HZ W/CORD,PLUG COVER,END SHIELD -NO GEAR BOX	1
203	5095031	1.5HP MOTOR 120 VOLT 60HZ 11:1 3P GEAR BOX	1
	-----	1.5HP MOTOR 120V60HZ W/CORD,PLUG COVER,END SHIELD-NO GEAR BOX	1
203	5095099	1.5HP MOTOR 240 VOLT 60HZ 11:1 3P GEAR BOX – REWIRE	1
	5095499	1.5HP MOTOR 240V60HZ W/END SHIELD W/OUT GEAR BOX REWIRE	1
203	5095041	1.5HP MOTOR 240 VOLT 50HZ 11:1 3P GEAR BOX	1
	5095441	1.5HP MOTOR 240V50HZ W/CORD,PLUG COVER,END SHIELD-NO GEAR BOX	1
203	5095069	1.5HP MOTOR 100 VOLT 50HZ 11:1 3P GEAR BOX – REWIRE	1
	5095469	1.5HP MOTOR 100V50HZ COMPLETE W/OUT GEAR BOX REWIRE	1
203A	5095211	GEAR BOX 11:1 3P W/OUT END SHIELD & FLEX COUPLING	1
203A	5095201	GEAR BOX 11:1 3P W/END SHIELD & FLEX COUPLING	1
203A1	5095301	COUPLING, FLEXIBLE	1
204	0393531	NSS LOGO LABEL - 3.5 X 4	1
205	9120850	1/4-20 X 5/16 SET SCREW - KNURL POINT - PACK OF 2	1
206	5390013	BASE	1
207	5390883	SKIRT - 17"	1
	5390873	SKIRT - 20"	1
208	9121390	11/32 I.D. X 11/16 O.D. X .051/.080 THICK FLAT WASHER (5/16) - PK-10	4
209	9121520	5/16 SPLIT LOCK WASHER - PACK OF 10	4
210	9121510	5/16-18 X 2 1/4 SOCKET HEAD CAP SCREW - PACK OF 2	4
211	5390861	BUMPER - 17"	1
	5390851	BUMPER - 20"	1
212	5092641	RETAINING RING	1
213	5990331	3/8" I.D. "O" RING	1
214	5390496	HANDLE PIVOT BAR	1
215	5092641	RETAINING RING	1
216	5990241	SOLUTION FEED TUBE	1
217	5390136	AXLE	1
218	9122705	1/2 I.D. X 3/4 O.D. X .01 THICK - 1 WAVE SPRING WASHER (1/2) - PACK OF 2	2
219	9122496	RETAINING RING - PACK OF 8	2
220	9122465	.516 I.D. X .813 O.D. X .027/.030 THICK FLAT WASHER - PACK OF 2	2
221	5092591	WHEEL - 5" - WITH PLASTIC BEARING	2
222	9122705	1/2 I.D. X 3/4 O.D. X .01 THICK - 1 WAVE SPRING WASHER (1/2) - PACK OF 2	1
223	5390811	1/2 I.D. X 1 O.D. X .07 THICK FLAT WASHER – NYLATRON	2
224	5390026	HANDLE BRACE	2
225	9122140	3/8-16 HEX NUT WITH NY-LOK INSERT - PACK OF 5	1
226	0393631	PLUG/CORD COVER – HANDLE	1
227	5390826	TUBE CLAMP SHOE	1
228	5391891	HANDLE	1
229	5390201	RUBBER TUBING	1
230	0393141	FLATTENED CLAMP BOLT	1
231	0393131	SLOTTED WASHER	1
232	9121420	5/16-18 HEX NUT - PACK OF 10	1

BASE ASSEMBLY

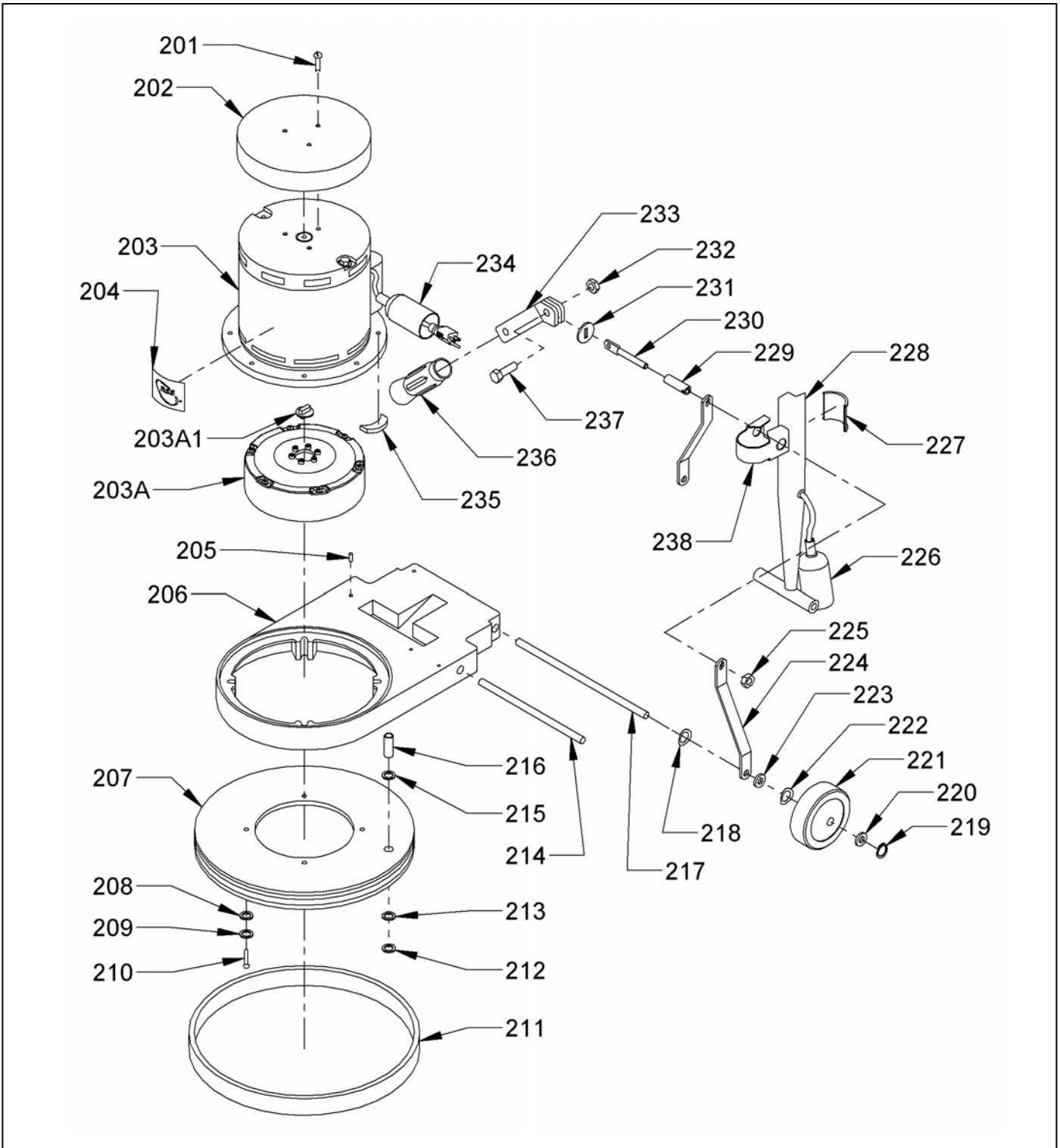

<u>ITEM</u>	<u>PART NO.</u>	<u>DESCRIPTION</u>	<u>QTY</u>
233	0393121	CLAMP LEVER	1
234	0393621	PLUG/CORD COVER – MOTOR	1
235	5091691	RUBBER PAD	4
236	0393321	HANDLE GRIP	1
237	9121680	5/16-18 X 1 HEX BOLT - PACK OF 5	1
238	5390043	TUBE CLAMP	1

MOTOR

<u>ITEM</u>	<u>PART NO.</u>	<u>DESCRIPTION</u>	<u>QTY</u>
203	5095011	1 HP MOTOR 120 VOLT 60 HZ 11:1 2P GEAR BOX - INCLUDES:	1
	5095411	1 HP MOTOR 120 VOLT 60 HZ W/CORD, PLUG COVER, END SHIELD - NO GEAR BOX	1
	5095201	GEARBOX - 11:1 RATIO WITH END SHIELD & FLEX COUPLING	1
	5095211	GEARBOX - 11:1 RATIO WITH OUT END SHIELD & FLEX COUPLING	1
	0394511	STATIONARY SWITCH – IMPERIAL	1
	0394581	MOTOR CORD	1
	0393621	PLUG / CORD COVER – MOTOR	1
	0394591	CAPACITOR - RUN - 50uF 370V	1
	0394641	CAPACITOR - START - 240uF 165V US	1
	203	5095079	1 HP MOTOR 240 VOLT 60 HZ 11:1 2P GEAR BOX - REWIRE - INCLUDES:
5095479		1 HP MOTOR 240 VOLT 60 HZ W/END SHIELD W/OUT GEAR BOX – REWIRE	1
5095201		GEARBOX - 11:1 RATIO WITH END SHIELD & FLEX COUPLING	1
5095211		GEARBOX - 11:1 RATIO WITH OUT END SHIELD & FLEX COUPLING	1
0394511		STATIONARY SWITCH – IMPERIAL	1
0394581		MOTOR CORD	1
0393621		PLUG / CORD COVER – MOTOR	1
0394591		CAPACITOR - RUN - 50uF 370V	1
0394641		CAPACITOR - START - 240uF 165V US	1
203		5095021	1 HP MOTOR 240 VOLT 50 HZ 11:1 2P IMP - INCLUDES:
	5095421	1 HP MOTOR 240 VOLT 50 HZ W/CORD,PLUG COVER,END SHIELD - NO GEAR BOX	1
	5095201	GEARBOX - 11:1 RATIO WITH END SHIELD & FLEX COUPLING	1
	5095211	GEARBOX - 11:1 RATIO WITH OUT END SHIELD & FLEX COUPLING	1
	0394511	STATIONARY SWITCH – IMPERIAL	1
	0394581	MOTOR CORD	1
	0393621	PLUG / CORD COVER – MOTOR	1
	0394631	CAPACITOR - RUN - 60uF 370V	1
	0394641	CAPACITOR - START - 240uF 165V US	1
	203	5095031	1.5 HP MOTOR 120 VOLT 60 HZ 11:1 3P - INCLUDES:
-----		1.5 HP MOTOR 120 VOLT 60 HZ W/CORD,PLUG COVER,END SHIELD - NO GEAR BOX	1
5095201		GEARBOX - 11:1 RATIO WITH END SHIELD & FLEX COUPLING	1
5095211		GEARBOX - 11:1 RATIO WITH OUT END SHIELD & FLEX COUPLING	1
0394511		STATIONARY SWITCH – IMPERIAL	1
0394581		MOTOR CORD	1
0393621		PLUG / CORD COVER – MOTOR	1
0394631		CAPACITOR - RUN - 60uF 370V	1
0394641		CAPACITOR - START - 240uF 165V US	1
203		5095099	1.5 HP MOTOR 240 VOLT 60 HZ 11:1 3P REW - INCLUDES:
	5095499	1.5 HP MOTOR 240 VOLT 60 HZ W/END SHIELD W/OUT GEAR BOX – REWIRE	1
	5095201	GEARBOX - 11:1 RATIO WITH END SHIELD & FLEX COUPLING	1
	5095211	GEARBOX - 11:1 RATIO WITH OUT END SHIELD & FLEX COUPLING	1
	0394511	STATIONARY SWITCH – IMPERIAL	1
	0394581	MOTOR CORD	1
	0393621	PLUG / CORD COVER – MOTOR	1
	0394631	CAPACITOR - RUN - 60uF 250V	1
	0394641	CAPACITOR - START - 240uF 165V US	1
	203	5095041	1.5 HP MOTOR 240 VOLT 50 HZ 11:1 3P - INCLUDES:
5095441		1.5 HP MOTOR 240 VOLT 50 HZ W/CORD,PLUG COVER,END SHIELD - NO GEAR BOX	1
5095201		GEARBOX - 11:1 RATIO WITH END SHIELD & FLEX COUPLING	1
5095211		GEARBOX - 11:1 RATIO WITH OUT END SHIELD & FLEX COUPLING	1
0394511		STATIONARY SWITCH – IMPERIAL	1
0394581		MOTOR CORD	1
0393621		PLUG / CORD COVER – MOTOR	1
0394631		CAPACITOR - RUN - 60uF 250V	1
0394641		CAPACITOR - START - 240uF 165V US	1
203		5095069	1.5 HP MOTOR 100 VOLT 50 HZ 11:1 3P REWIRE - INCLUDES:
	5095469	1.5 HP MOTOR 100 VOLT 50 HZ W/CORD,PLUG COVER,END SHIELD - NO GEAR BOX	1
	5095201	GEARBOX - 11:1 RATIO WITH END SHIELD & FLEX COUPLING	1
	5095211	GEARBOX - 11:1 RATIO WITH OUT END SHIELD & FLEX COUPLING	1
	0394511	STATIONARY SWITCH – IMPERIAL	1
	0394581	MOTOR CORD	1
	0393621	PLUG / CORD COVER – MOTOR	1
	0394631	CAPACITOR - RUN - 60uF 250V	1
	0394641	CAPACITOR - START - 240uF 165V US	1

ACCESSORIES

PART NO. DESCRIPTION



- 2890101 PLASTIC CLUTCH PLATE - 5" DIAMETER - 6 HOLES
- 2890981 PLASTIC CLUTCH PLATE - 4" DIAMETER - 3 HOLES
- 2890991 ALUMINUM CLUTCH PLATE - 5" DIAMETER - 6 HOLES
- 2893001 ALUMINUM CLUTCH PLATE - 4" DIAMETER - 3 HOLES



- 2897211 17" POLY BACK TUFTED PAD DRIVER
- 2897601 17" STRUCTURAL FOAM PAD DRIVER
- 2897201 17" POLY BACK NYLON FILL SCRUB BRUSH - LIGHT TO MEDIUM SCRUB
- 2897711 17" POLY BACK NYLON GRIT FILL SCRUB BRUSH - HEAVY CONCRETE SCRUB
- 2897821 17" POLY BACK NYLON - SOFT SCRUB BRUSH - CARPET ONLY
- 2897901 17" POLY BACK SCRUB GRIT BRUSH - MILD TO MEDIUM SCRUB



- 2892211 20" POLY BACK TUFTED PAD DRIVER
- 2892601 20" STRUCTURAL FOAM PAD DRIVER
- 2892201 20" POLY BACK NYLON FILL SCRUB BRUSH - LIGHT TO MEDIUM SCRUB
- 2892651 20" POLY BACK NYLON FILL SCRUB BRUSH - WITH GUIDE FOR CARPET SHAMPOOING
- 2892711 20" POLY BACK NYLON GRIT FILL SCRUB BRUSH - HEAVY CONCRETE SCRUB
- 2892031 20" PLASTIC BACK BASSINE SCRUB BRUSH - GENERAL SCRUB
- 2892701 20" POLY BRUSH - SHOWER FEED - STANDARD CARPET SCRUB
- 2892901 20" POLY BACK SCRUB GRIT BRUSH - MILD TO MEDIUM SCRUB

NOTE: ALL PADS COME 5 PADS PER CASE

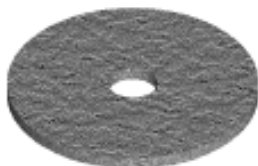

- 7991751 17" LITE BLUE POLISH/BURNISH PAD - SOFT FINISH
- 7991741 17" UHS CLEAN BUFF PAD - REMOVE SCUFF MARKS NOT FINISH
- 7991731 17" BLUE SCRUB PAD - TOP SCRUB AND LIGHT FINISH REMOVAL
- 7991721 17" GREEN SCRUB PAD - HEAVY FINISH REMOVAL
- 7991701 17" BLACK STRIP PAD - REMOVES FINISH COMPLETELY

- 7992051 20" LITE BLUE POLISH/BURNISH PAD - SOFT FINISH
- 7992041 20" UHS CLEAN BUFF PAD - REMOVE SCUFF MARKS NOT FINISH
- 7992031 20" BLUE SCRUB PAD - TOP SCRUB AND LIGHT FINISH REMOVAL
- 7992021 20" GREEN SCRUB PAD - HEAVY FINISH REMOVAL
- 7992001 20" BLACK STRIP PAD - REMOVES FINISH COMPLETELY
- 7992011 20" BROWN STRIP PAD - REMOVES FINISH COMPLETELY

- 5094771 DELUXE SOLUTION TANK - 3.5 GALLON WITH BRASS VALVES



NSS® Enterprises, Inc.

3115 Frenchmens Road
 Toledo, Ohio 43607
 PHONE (419) 531-2121
 FAX (419) 531-3761
mailus@nss.com
www.nss.com