

T3



## Walk-behind Floor Scrubber

- Just-scrubbed floors are immediately clean, dry and safe for traffic with ec-H2O™ or FaST® technologies
- 75% lower sound level (68.5 dBA)
- Easily cleanable, sanitary Hygenic® solution and recovery tanks



The Safe Scrubbing Alternative®

## A high-performance scrubber to match your higher standards with ec-H2O or FaST technologies

### Improve environmental health in your facility

Exclusive Hygenic tanks allow for easy access and sanitization, reducing mold, bacteria and other contaminants that can grow in enclosed tanks.

### Quietly clean in noise-sensitive environments

At only 68.5 decibels, the T3 is 75% quieter than leading competitive models – comparable to normal conversation levels.

### Leave behind no cleaning solution

Even around 180-degree turns, the T3's equal-pressure, parabolic squeegee recovers all cleaning solution from the floor.



### ENGINEERED FOR SAFETY

**Minimize the risk of slip-and-fall injuries and help control insurance costs.** Floors are clean, dry and safe for foot traffic immediately when scrubbed with ec-H2O or FaST.

**Reduce operator fatigue and increase productivity.** Ergonomic design makes cleaning with the T3 more comfortable for your staff.

**Increase scrubbing effectiveness and quality.** Clear sight lines and simple controls mean operators can focus solely on their cleaning environment.



## Exclusive Technologies (optional cleaning innovations)

**ecH2O™**  
Electrically converted water

**FaST**  
Foam-activated chemical

Increase safety	<ul style="list-style-type: none"> <li>• High traction certified by NFSI</li> <li>• Reduce chemical accidents</li> </ul>	<ul style="list-style-type: none"> <li>• High traction certified by NFSI</li> <li>• Eliminate measuring and mixing</li> </ul>
Reduce costs	<ul style="list-style-type: none"> <li>• Eliminate purchase of daily cleaners</li> <li>• Reduce water consumption and disposal by up to 70%</li> </ul>	<ul style="list-style-type: none"> <li>• Reduce chemical usage up to 90%</li> <li>• Reduce water consumption and disposal by up to 70%</li> </ul>
Soil type	<ul style="list-style-type: none"> <li>• Replace daily cleaners</li> <li>• Effective on food-based oils and greases</li> </ul>	<ul style="list-style-type: none"> <li>• Three grades of chemical from light-duty cleaner to heavy-duty degreaser</li> </ul>

**Both technologies increase scrub time up to three times**

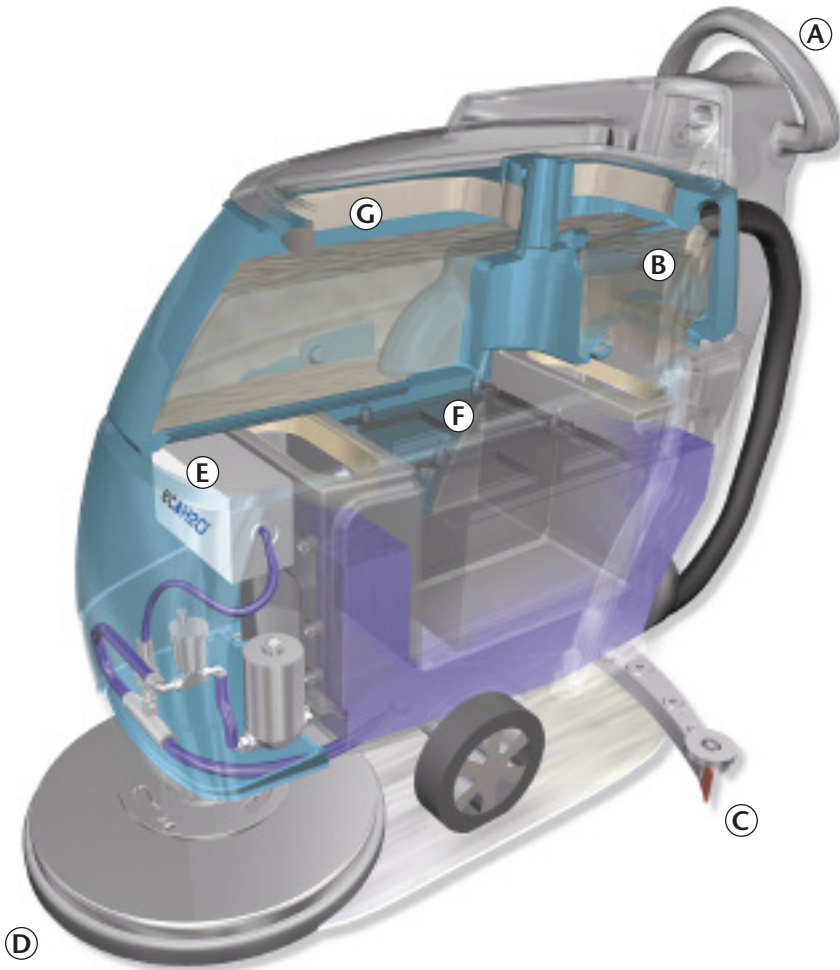

- A** Easily train new operators to use the simple, intuitive controls.
- B** Solution and recovery tanks easily cleanable. Exclusive Hygienic tanks are fully accessible for sanitization.
- C** Quickly remove and replace brushes and squeegees. Plus, with the “no hassle” squeegee system, there are no tools for maintenance and the blade is factory set at the optimum recovery angle.
- D** Eliminate the need for follow-up passes and non-productive mop-ups. A fully self-adjusting splash skirt captures 100% of scrub deck overspray.
- E** Scrub for up to 80 minutes on a single tank. Up to 90% longer than comparable machines with Green Seal certified FaST or chemical-free ec-H2O.
- F** Save time and storage space with the on-board charger.
- G** Eliminate operator contact with wastewater and prevent clogged hoses/drains with the convenient debris tray.

## Tennant Company Environmental Stewardship



ec-H2O and FaST technologies are NFSI (National Floor Safety Institute) Certified. NFSI certification ensures a product has passed a 2-phase testing process, proving the floor product helps to reduce potential for slip-and-fall accidents.



ec-H2O and FaST technologies are registered by NSF International. NSF International is an independent, not-for-profit organization that ensures formulation and labels on these products meet appropriate food safety regulations.



ec-H2O and FaST technologies may contribute to LEED or LEED-EBOM (Existing Building: Operations & Maintenance) points, provided other appropriate criteria are met. For more information on obtaining LEED points, please contact your sales rep or refer to the USGBC website at: [www.usgbc.org](http://www.usgbc.org).



FaST is a Green Seal (GS-37) Certified Detergent. Green Seal evaluates and certifies cleaning products based on criteria such as the toxicity of the product, skin and eye irritation, skin sensitization, combustibility, toxicity to aquatic life, and packaging.



Conserve Resources



Reduce Detergents



Increase Safety



Improve Air Quality



Reduce Noise

Choose GE Capital Solutions and U.S. Bank, our esteemed financial partners, for simple, quick financing with flexible upgrade options, and no long-term obligations.

## SEEING IS BELIEVING

See for yourself how the T3 scrubber can help you reach a higher standard of cleanliness and safety in your facility. For a demonstration or additional information, call [800.553.8033](tel:800.553.8033).

## T3 WALK-BEHIND FLOOR SCRUBBER

FEATURES	17 in Pad Assist	20 in Pad Assist (20 in w/Drive)
<b>Productivity (per hour)</b>		
Theoretical Max	20,230 ft <sup>2</sup> / 1,900 m <sup>2</sup>	23,800 ft <sup>2</sup> / 2,200 m <sup>2</sup>
Estimated Coverage* (Conventional)	8,440 ft <sup>2</sup> / 780 m <sup>2</sup>	10,125 ft <sup>2</sup> / 940 m <sup>2</sup> (16,065 ft <sup>2</sup> / 1,490 m <sup>2</sup> )
Estimated Coverage* (ec-H2O/FaST)	11,250 ft <sup>2</sup> / 1,050 m <sup>2</sup>	13,500 ft <sup>2</sup> / 1,260 m <sup>2</sup> (21,420 ft <sup>2</sup> / 2,000 m <sup>2</sup> )
<b>Brush/Pad Drive System</b>		
Cleaning path	17 in / 430 mm	20 in / 510 mm
Brush motor horsepower	1.0 hp	1.0 hp
Brush RPM	230 rpm	230 rpm
Brush/pad pressure	50 lbs / 23 kg & 90 lbs / 41 kg	50 lbs / 23 kg & 90 lbs / 41 kg
<b>Solution Delivery System</b>		
Solution tank description	Full access & cleanable	Full access & cleanable
Solution capacity	10.5 gal / 40 L	10.5 gal / 40 L
<b>Recovery System</b>		
Recovery tank description	Full access & cleanable	Full access & cleanable
Recovery tank capacity <small>(includes demisting chamber)</small>	15 gal / 57 L	15 gal / 57 L
Vacuum motor	0.5 hp – two stage	0.5 hp – two stage
Vac motor CFM	65 cfm / 1.84 cmm	65 cfm / 1.84 cmm
Vac motor sealed waterlift	40 in / 1,020 mm	40 in / 1,020 mm
<b>Battery System</b>		
System voltage	24 volt	24 volt
Battery amp hour rating	105 AH @ 20 hr	130 AH @ 20 hr (155 AH @ 20 hr)
Battery run time <small>(continuous cleaning rating)</small>	2.5 hours	2.5 hours (3 hours)
<b>Dimensions/Weights</b>		
Product height	43 in / 1,090 mm	43 in / 1,090 mm
Product length	48 in / 1,220 mm	50.25 in / 1,280 mm
Product width <small>(with squeegee)</small>	30 in / 760 mm	30 in / 760 mm
Product weight <small>(with batteries)</small>	319 lbs / 145 kg	343 lbs / 156 kg (391 lbs / 177 kg)
<b>Total Power Consumption</b>		
Power consumption amps	27 amp nominal	29 amp nominal (30 amp nominal)
<b>Decibel Rating</b>		
Operator's position	68.5 dBA	68.5 dBA
<b>Warranty</b>	See your local representative for warranty information	

\* Estimated coverage rates use the practical speed and empty/fill time standards from the 2004 ISSA Cleaning Times handbook.

\*\* Run times are based on continuous scrubbing run times.

\*\*\* Sound levels per ISO 11201 as recommended by the American Association of Cleaning Equipment manufacturers & OSHA.

### Tennant

P.O. Box 1452  
Minneapolis, MN 55440-1452  
800.553.8033 | 763.540.1200  
In Quebec: 514.335.6061

[www.tennantco.com](http://www.tennantco.com)  
[info@tennantco.com](mailto:info@tennantco.com)