

PREDATOR CXC100

IMPORTANT SAFETY INSTRUCTIONS

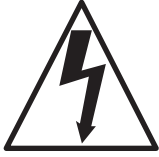

READ AND UNDERSTAND ALL INSTRUCTIONS
BEFORE OPERATING OR SERVICING MACHINE

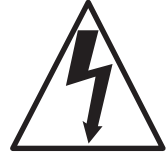

DANGER!

Failure to Observe These Instructions Can Cause Personal Injury
to Machine Operator, By-standers or Possible Machine Damage.

- **NEVER** attempt to service or perform maintenance functions while machine is plugged into an electrical outlet.
- **ALWAYS** unplug machine before attempting to service the motorized brush attachment.
- **NEVER** operate in standing water. **NEVER** expose to rain. **ALWAYS** store indoors.
- **NEVER** overfill recovery tank or allow water to enter vacuum standpipe. This will cause damage to the vacuum motor and possible electrocution.
- **NEVER** operate machine with a cut, abraded or taped cord.
- **NEVER** operate machine with a broken grounding blade on the plug.
- **ALWAYS** replace the entire cord when the cord or plug is damaged in any manner.
- **NEVER** handle the machine, cord or plug with wet hands.
- **NEVER** drop or insert any object into any machine opening.
- **ALWAYS** keep face, fingers, hair or any other body part, or loose clothing away from any machine opening or any moving part, particularly the revolving brush.
- **NEVER** leave the machine unattended when plugged in. Unplug the machine from the electrical outlet when not in use.
- **ALWAYS** turn the machine off before unplugging it from the electrical outlet.
- **NEVER** operate this machine in the presence of flammable or combustible liquids or fumes.
- When any electrical motor, switch, cord or plug service is required, maintenance should only be done by an authorized service station, an electrician or other qualified persons.
- **NEVER** operate this machine if it is not working properly, if it has been dropped, damaged, exposed to weather, or dropped into water. Return the machine to a service center for examination and repair.
- **NEVER** operate this machine with any air opening blocked. Keep all air openings free of dust, lint, hair, ect.
- **NEVER** operate this machine without solution tank filter screens or vacuum standpipe filter screen in place or if they are clogged. Clean all filter screens after every use.
- **ALWAYS** store this machine indoors. Protect it from rain or snow.
- **NEVER** spray the top of the machine with liquids.
- **DO NOT** pull or carry this machine by the electrical supply cord, use the cord as a handle, close a door on the cord, pull the cord around sharp edges or corners, or expose to heated surfaces.
- **NEVER** disconnect the plug by pulling on the cord. To disconnect the cord from the outlet grasp the plug, not the cord.
- **ALWAYS** unplug this machine before attempting to service.
- **ALWAYS** use a defoamer which will prevent a buildup of foam in the recovery tank. If a defoamer is not used, the motor can be damaged from shampoo being pulled into the vacuum motor.

SAVE THESE INSTRUCTIONS



INFORMATION & OPERATING INSTRUCTIONS

**DO NOT OPERATE MACHINE UNTIL YOU HAVE READ THIS SECTION
IMPROPER USE OF THE PREDATOR CXC100 WILL VOID THE WARRANTY**

1. Always use defoamer when foaming occurs to prevent vac motor damage.
2. To keep fitting and lines from damage during freezing conditions, use an anti-freeze in the pump or keep equipment inside heated areas.
3. All extension cords must be at least size #12 (12/3) and no longer than 50 ft.
4. Do not let pump run dry.
5. Use neutral pH, water-based products only - NO SOLVENTS!

INSPECTION:

Carefully unpack and inspect the PREDATOR CXC100 for shipping damage. Each unit is tested and inspected before shipment. Any damage incurred during shipping is the responsibility of the carrier, who should be notified immediately.

CLEANING SOLUTIONS:

We recommend liquid cleaning chemicals. Powders may be used, but unless mixed very thoroughly, they could cause build-up in the lines, pump, quick-disconnects, etc. A pH of 7-9 is strongly recommended to avoid premature pump wear, which would void the warranty.

MAINTENANCE:

For optimum performance, flush the machine with clear water at the end of each working day. Once a month, minimum, run a flushing compound through the machine to cut any alkaline build-up that may have formed.

Lubricate wheels, casters and hinges as needed. The pump and vacuum motors do not require any maintenance.

The body can be cleaned with a general all-purpose detergent and protected with a silicone type product like Armor All®. The quick-disconnects should be lubricated with silicone, also.

Prior to each job, inspect the holding tank filter and the recovery tank float filter for hair and dirt. The drain valve should also be inspected regularly and kept free of any debris or build-up.

SET-UP:

Fill the holding tank with clear water and add the detergent of your choice. Mix well. Plug in the electrical cord and turn on the pump and vacuum switches. You are now ready to begin cleaning.

PUMP OPERATION:

The 100 PSI-pump is a "demand" type design. The pump runs only when you depress the lever on your wand. When you release the lever the pump shuts off.

VACUUM OPERATION:

A switch is provided for each vacuum motor. The machine can operate on either one or two vac motors. A patented vacuum manifold reduces the oscillations between the two vacuum motors in series, thereby increasing the efficiency and life of the vacuum motors.

BALL FLOAT VAC SHUTOFF:

When the recovery tank is full, the float system will shut off the incoming air flow and prevent water from entering the vacuum motors. The float may not work properly if the float filter is clogged or if there is heavy foam in the tank.

CAUTION: To avoid vac motor damage, always make sure the float filter is clean and the ball travels freely before turning on the machine. Use a defoamer whenever foam is present.

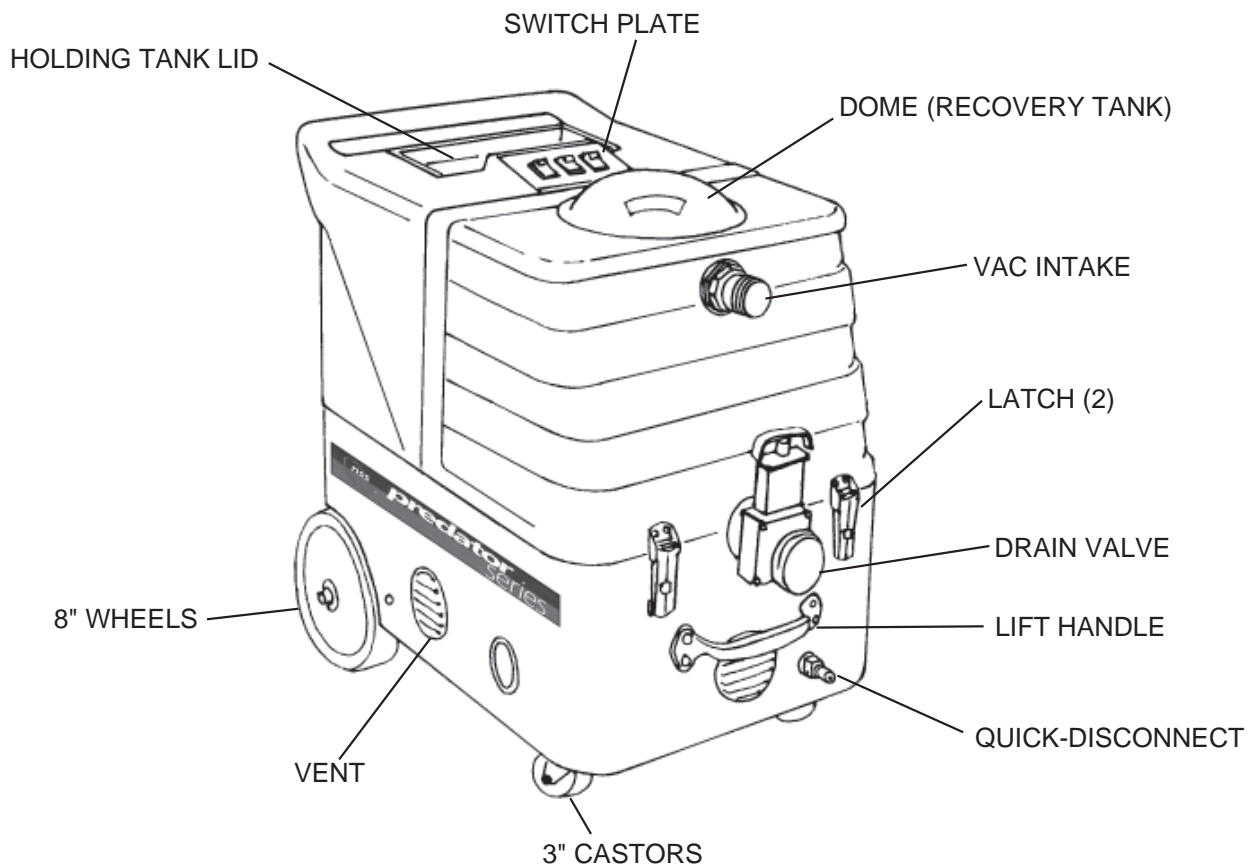

PREDATOR CXC100 PARTS LIST

<u>ITEM #</u>	<u>PART #</u>	<u>DESCRIPTION</u>	<u>ITEM #</u>	<u>PART #</u>	<u>DESCRIPTION</u>
#1	4091011	Metal "T" Handle	#31A	9120900	1/4 Hex Nut, Ny-Lok, ZP
#1A	4091231	Drain Gate	#32	4090611	1/3-20 X 3/4" Hex Bolt, ZP
#2	4090581	Screw, 10-32 X 5/8, S/S	#33	4091141	Axle Bracket
#3	4091251	Latch	#34	9120900	1/4 Hex Nut, Ny-Lok, ZP
#4	4091161	O-Ring, Thin	#35	4091361	Wheel, 8 inch, non-marking
#4A	4091171	O-Ring, Thick	#36	4091021	Axle Cap
#4B	4090701	Nut, Cast Aluminum	#37	4091271	Axle, 1/2" X 18-13/16"
#5	4091661	Vacuum Tank, Black, specify model	#38	4091331	PVC Reducer
#6	4091241	Hose Barb, 1-1/2"	#39	4091641	Holding Tank
#7	4091291	PVC Elbow, 1-1/2"	#40	4091191	Filter, Pump Inlet, 40 Mesh, S/S
#8	4091391	Gasket, for Vacuum Dome	#41	4091601	Lid, with hinges and Label
#9	4091581	Vacuum Dome	#42	4090101	Switch Plate, (empty) CXC100
#10	4091571	Vac Shut-off, manifold Assy.	#42A	4090511	#4 X 3/8" Screw, Panhead, S/S
#10A	4091501	Ball & Cage	#43	4091041	Switch, SPST, Covered, w/light
#11	4090701	Nut, Cast Aluminum	#43A	4091041	Switch, SPST, Covered, w/light
#12	4091171	O-Ring, Thick	#43B	4091041	Switch, SPST, Covered, w/light
#13	4091291	PVC Elbow, 1-1/2"	#44	4091381	Pump, 100 PSI, 120V
#14	4091121	Hose Clamp, size 28		4092121	Pump, 100 PSI, 240V
#15	4091551	Hose, Rubber, 2" X 20"		4091481	Rebuild Kit for 100 PSI pump
#15A	4091561	Hose, Rubber, 2" X 16"	#45	4091131	Hose Clamp, 3/8-7/8
#16	4091211	Vacuum Motor, 2-stage, 120V	#46	4091101	Hose Barb & Elbow, plastic
	4092101	Vacuum Motor, 2-stage, 240V	#47	4091531	Hose, Rubber, 3/8 X 13"
#16A	4091431	Gasket, Vac Motor	#48	4092041	Hose, Rubber, 3/8" X 22"
#17	9120900	1/4-20 Hex Nut w/ Ny-Lok	#49	4091441	Fan, Cooling, 100CFM, 120V
#18	9120930	3/16 Flat Washer, ZP		4092131	Fan, Cooling, 100CFM, 240V
#19	4090621	1-1/4-20 X 3-1/2" Hex Bolt	#50	4091451	Fan Guard
#19A	9120920	1/4" Hex Nut, Finish	#51	4090541	6-32 X 2" Screw, Panhead, S/S
#19B	9120880	1/4 Split Lock Washer	#52	4090531	6-32 Hex Nut, Ny-Lok, ZP
#20	4091181	Split Ring	#53	4091521	Cord Wrap, Black
#21	4091631	Stop Chain, 13"	#54	1391161	Washer, Plastic, 5/8OD X3/8ID X 1/16
#22	4091651	Manifold, Vacuum, #3 or #4	#55	4090671	3/8 Acorn Nut, Nickel Plated
#22A	4091651	Manifold, Vacuum, #3 or #4	#56	4090061	Label, CXC100, NSS
#23	4091411	Exhaust Flange	#57	4091081	Elbow, Brass, Street
#24	4090601	1/4-20 X 3/4" Screw, Flathead Phillips	#58	4093011	Hose Barb, 1/4 mpt X 3/8 hose
#25	4091401	Handle, Chrome	#59	4091611	Gasket
#26	4091031	Quick Disconnect, male, 1/4 p.t.			
#27	9122470	Washer, Brass, 1" X 9/16 ID X 1/16"			<u>NOT SHOWN</u>
#28	4091311	Louver, 3" (includes 3 screws)	4090251		Power Cord, 120V
#29	4091261	Latch Strike	4090261		Power Cord, 240V
#30	4091511	Base, CXC & CXH (specify)			
#31	4091351	Castor, 3" Swivel			

PREDATOR CXC100

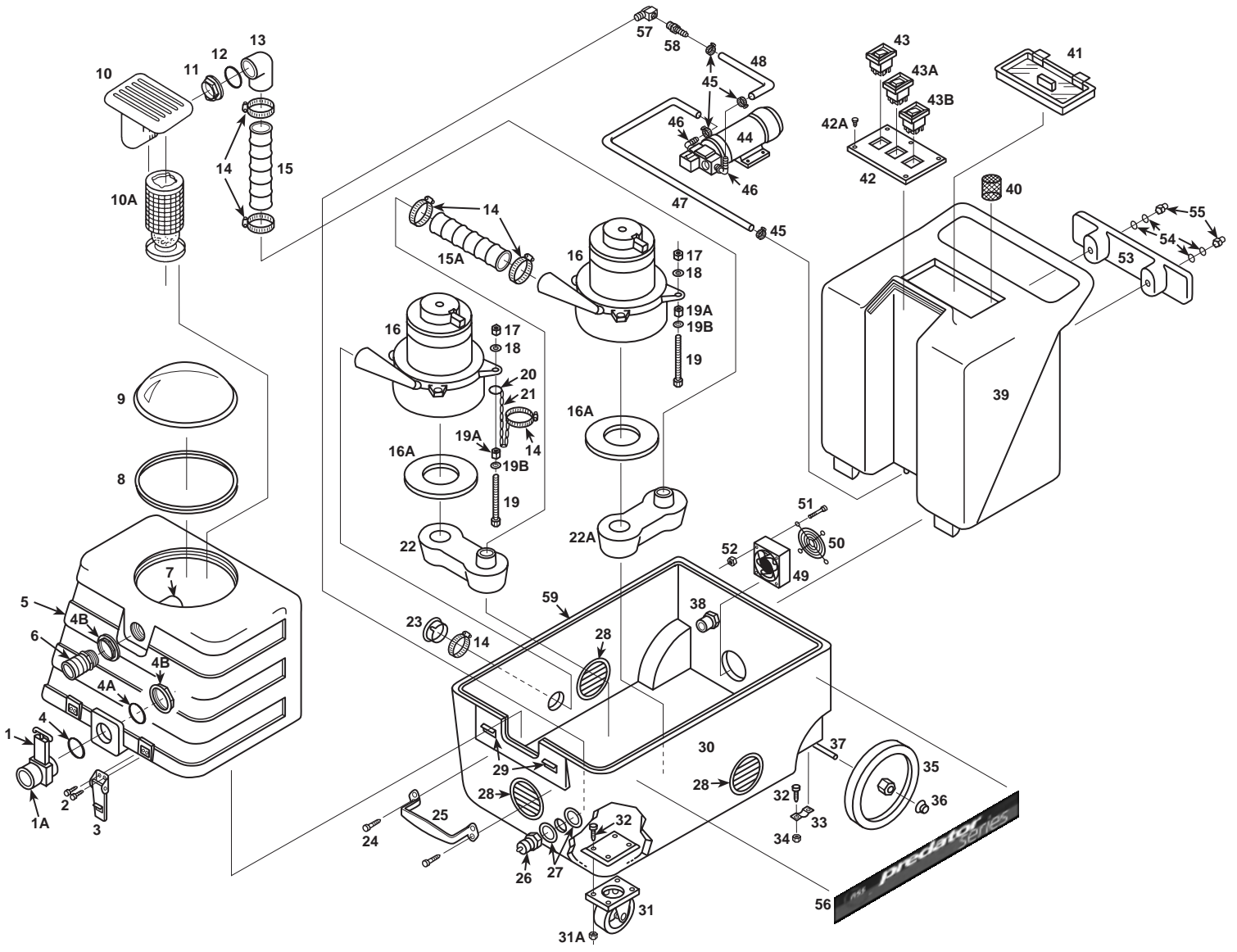

COMMON STAINS AND CLEANING TREATMENTS

TREATMENT METHODS

- First: Remove excess material by blotting to absorb liquids, or by scraping with a dull edge (butter knife) if a solid.
- Second: Clean the remaining stain as directed by the chart below. Always follow the direction on the container. Apply the cleaning material directly to the stain (avoid over wetting the carpet or upholstery), then remove the loosened stain material with a white absorbent cloth or tissue.
- Third: When the carpet is dry, gently brush the carpet pile to restore its appearance.
- Note: Treat unknown stains with a volatile solvent first and follow with other agents as required. If you are uncertain of the effect of the cleaning agent on the carpet fiber or dye, test on an inconspicuous area first.

STAIN TYPE

TREATMENT MATERIAL

Asphalt	Volatile solvent/detergent
Beer	Liquid detergent, White vinegar
Berry stain	Liquid detergent, Ammonia 3-6%, Water
Bleach	Liquid detergent, Water
Blood (dried)	Warm detergent, Ammonia 3-6%, Water
Blood (wet)	Liquid detergent, Water
Butter	Volatile solvent
Catsup or Mustard	Liquid detergent
Chewing gum	Volatile solvent
Chocolate	Liquid detergent, Ammonia water
Coffee	Detergent, White vinegar, Volatile solvent
Cola drink	Liquid detergent
Creme de Menthe (green)	Liquid detergent
Egg (raw)	Liquid detergent
Food dye	Liquid detergent, Water
Furniture dye or polish	Paint/Oil/Grease remover, Detergent
Gravy	Liquid detergent
Lipstick	Paint/Oil/Grease remover
Mascara	Paint remover, Volatile solvent, Detergent, Water
Milk	Liquid detergent
Orange drink	Liquid detergent, Water
Shoe polish	Heated iron into clean towel, Volatile solvent
Tea	Liquid detergent
Tomato Juice	Liquid detergent
Urine	Liquid detergent, Water
Vomit	Warm detergent, Water, White vinegar
Wine	Liquid detergent, Ammonia 3-6%, Water, Vinegar

PREDATOR CXC100

WIRING DIAGRAM

120V & 240V

*NOTE: Switches sit upside down in switch plate.

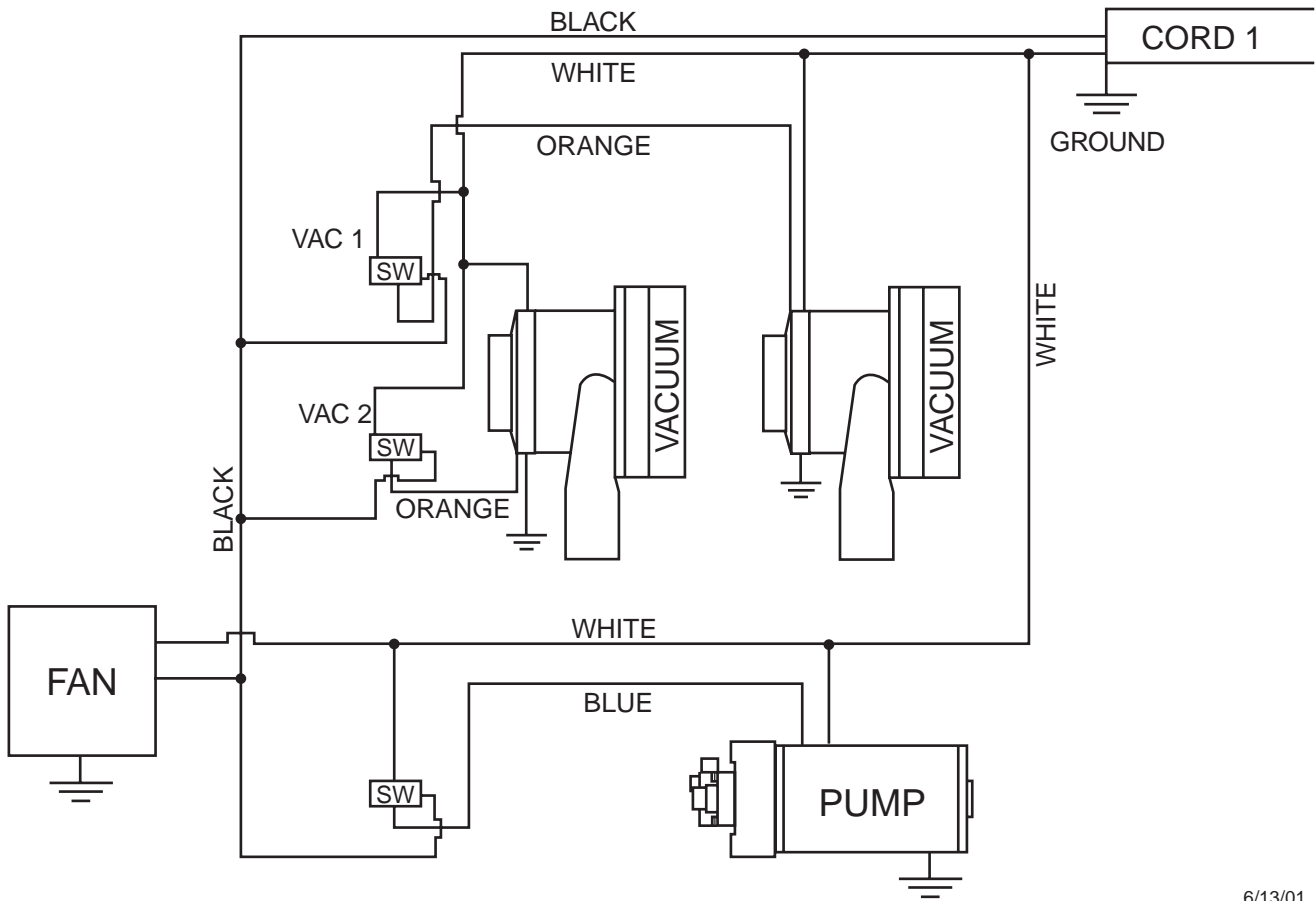



NSS Enterprises, Inc.

3115 Frenchmens Road, Toledo, Ohio 43607
PHONE (419) 531-3761 • FAX (419) 531-3761

NSS® Enterprises, Inc. European Distribution Centre

™ Unit II, Pinfold Trading Estate 55 Nottingham Road
STAPLEFORD, NOTTINGHAM NG9 8AD ENGLAND U.K.
PHONE: (44) 0115 939 1568 FAX: (44) 0115 949 0615