

PARTS LIST

ELECTRIC CHARGER 2500

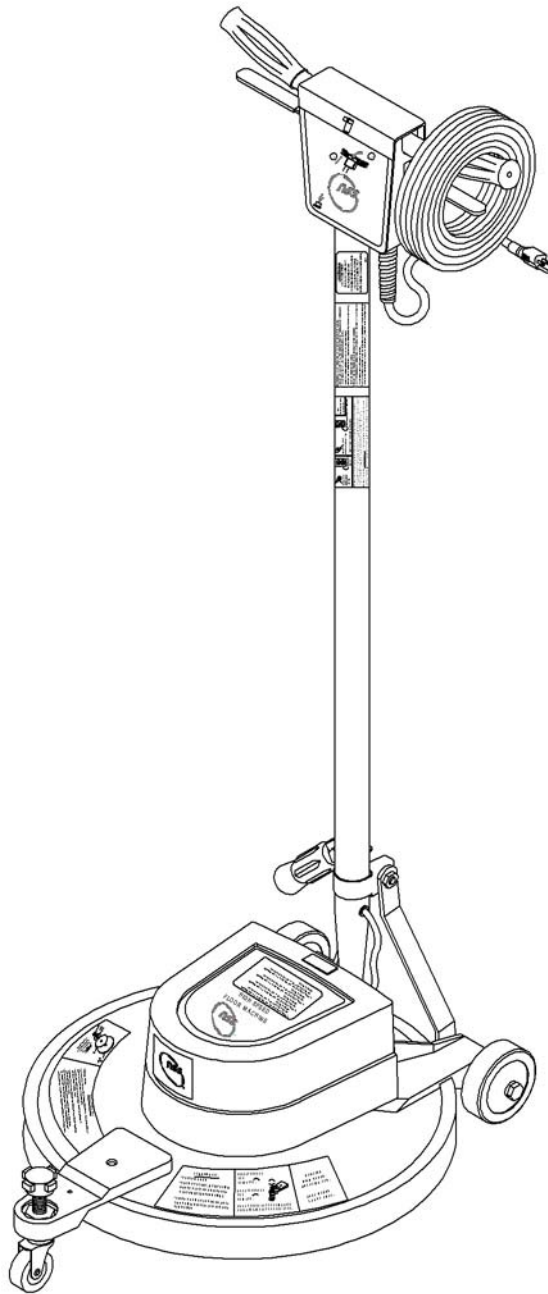

MOTOR ASSEMBLY

<u>ITEM</u>	<u>PART NO.</u>	<u>DESCRIPTION</u>	<u>QTY</u>
	5298351	MOTOR 115 VOLT 2500	1
101	5991731	COMMUTATOR BRACKET COVER	1
102	5298441	COMMUTATOR BRACKET ASSEMBLY WITH BRUSH, BOARD, LEADS - INCLUDES:	1
	5298451	COMMUTATOR BRACKET MACHINED	1
102A	5295071	BRUSH BOARD ASSEMBLY WITH DETECTORS, AND LEADS, INCLUDES:	1
102A1	5293651	CARBON BRUSH	4
102A2	2797571	BRUSH SPRING	4
102B	9120600	#10-24 X 1/2 SELF TAPPING SCREW – PACK OF 10	5
103	5991701	THRU BOLT	2
104	5298501	BRACKET - BOTTOM END	1
105	5298431	ARMATURE ASSEMBLY WITH BEARINGS - INCLUDES:	1
105A	5991541	BEARING - BOTTOM END	1
105B	9120827	3/16 SQUARE X 1 LONG KEY – PACK OF 2	1
105C	5991551	BEARING - TOP END	1
106	-----	HELICAL WASHER	1
107	5991521	STATOR FRAME ASSEMBLY - WITH CLIPS AND MAGNETS	1
108	5991661	#8-32 X 1.125 MOUNTING SCREW	2
109	-----	M8 FLAT WASHER – BRASS	2
110	5492741	RECTIFIER	2
111	5991681	HEX NUT WITH STAR LOCK WASHER	2
112	5298461	STRAIN RELIEF	1
113	5298491	LEAD ASSEMBLY AMP METER	2
114	5298481	LEAD ASSEMBLY MOTOR CORD	1
115	5991591	STRAIN RELIEF	1

MOTOR ASSEMBLY

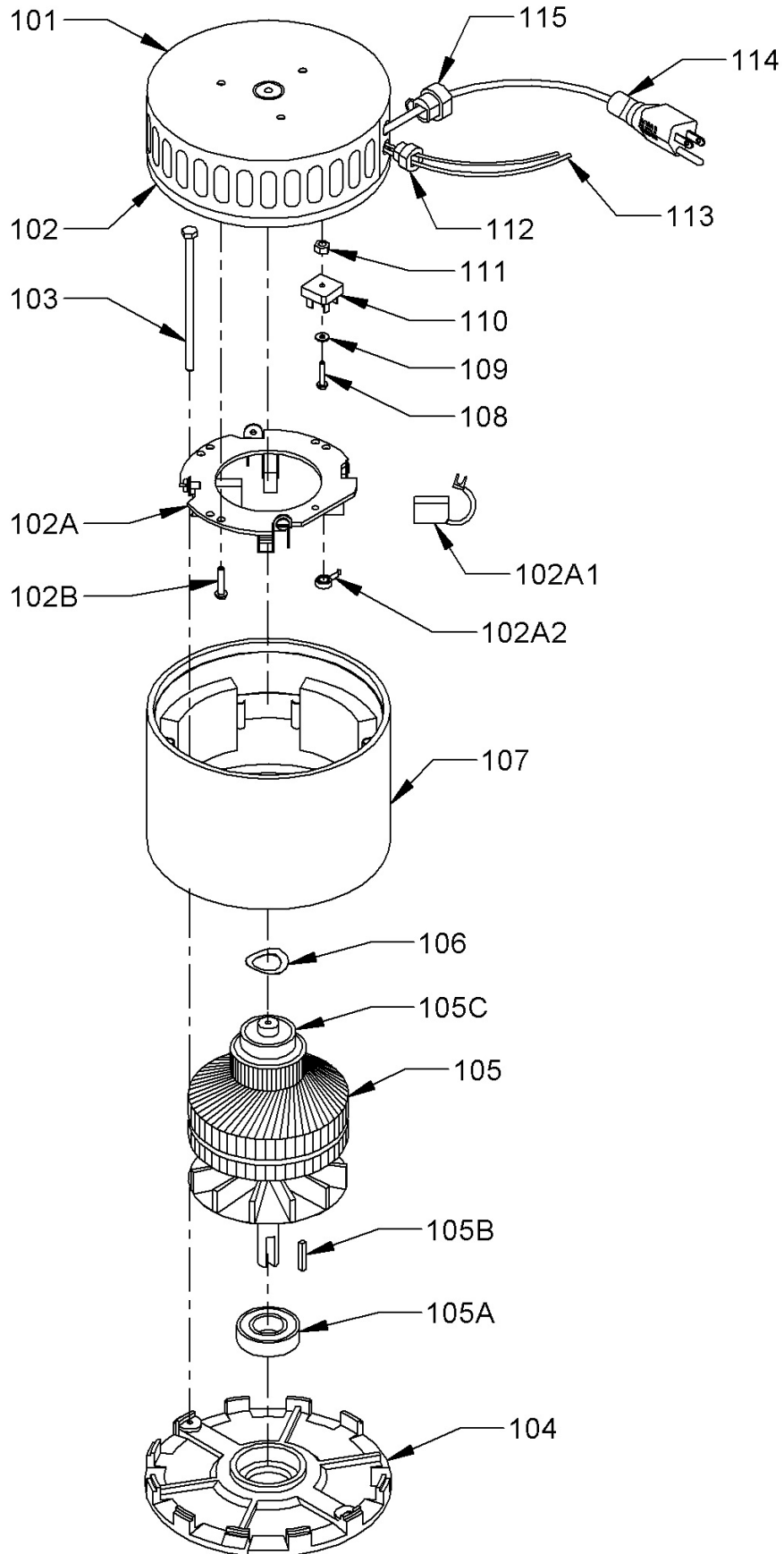

HANDLE ASSEMBLY

ITEM	PART NO.	DESCRIPTION	QTY
	5297649	HANDLE ASSEMBLY - 2500 - 115 VOLT	1
201	5391873	SWITCH BOX COVER	1
202	5392421	SWITCH BOX WITH CIRCUIT BREAKER ICON	1
203	0393511	SAFETY LOCKOUT BRACKET	1
204	0393521	SAFETY LOCKOUT	1
205	9120828	1/8 X 1 3/4 ROLL PIN - PACK OF 4	2
206	5390171	SWITCH LEVER SPRING	2
207	0393411	GRIP - SWITCH LEVER	2
208	0393401	SWITCH LEVER	1
209	9120100	#6-32 X 1 ROUND HEAD PHILLIPS MACHINE SCREW - PACK OF 10	2
210	9120130	#6 EXTERNAL STAR LOCK WASHER - PACK OF 10	2
211	5390211	SWITCH	1
212	5390361	SWITCH INSULATOR	1
213	5391321	WIRE NUT, ORANGE	1
214	0294031	# 8 RING TERMINAL 16-14 AWG	1
215	9120380	#10-24 X 3/8 ROUND HEAD PHILLIPS MACHINE SCREW - PACK OF 10	1
216	9120320	#10 SPLIT LOCK WASHER - PACK OF 10	1
217	0298981	# 10 RING TERMINAL 16-14 AWG	1
218	5490441	BREAKER LEAD – INSULATION	1
219	9120430	#10-24 X 3/4 ROUND HEAD PHILLIPS MACHINE SCREW - PACK OF 10	2
220	5294381	17 1/2 AMP CIRCUIT BREAKER	1
221	9120320	#10 SPLIT LOCK WASHER - PACK OF 10	2
222	9120360	#10-24 HEX NUT WITH STAR LOCK WASHER - PACK OF 10	2
223	5490451	CIRCUIT BREAKER LEAD - 4" WITH TERMINALS	1
224	9120200	#8 SPLIT LOCK WASHER - PACK OF 10	1
225	9120223	#8-32 X 1/4 PAN HEAD PHILLIPS MACHINE SCREW - PACK OF 5	1
226	5390511	FOAM PAD	1
230	5391891	HANDLE, MAVERICK, CE	1
231	5091636	CORD HOOK CLAMP	1
232	9120880	1/4 SPLIT LOCK WASHER - PACK OF 10	2
233	9121010	1/4-20 X 3/4 TRUSS HEAD PHILLIPS MACHINE SCREW - PACK OF 5	2
234	5090441	NYLON BUSHING	2
235	5490861	HANDLE CORD	1
236	5293131	GROMMET	1
237	5293791	CORD - 75 FEET - 14-3 ST	1
	5091569	CORD - 50 FEET WITH TERMINALS – OPTIONAL	1
	0396281	CORD – TYPE I PLUG	1
238	5091682	CORD HOOK	1
239	5091671	STRAIN RELIEF METAL	1
240	5390261	STRAIN RELIEF NUT	3
241	5092371	CORD CLAMP, #1002-545 EVERLOCK	1
242	5091656	7/8 I.D. X 1 3/8 O.D. X .112 THICK FLAT WASHER	1
243	5095501	CORD CLAMP	1
244	8791070	3/8 I.D. X 1/2 O.D. VINYL HOSE	4"
245	9120025	#6-32 DOUBLE HOLE SWITCH SPEED NUT – PACK OF 1	1
246	0393441	HANDLE GRIP, BLACK	2
247	9120320	#10 SPLIT LOCK WASHER - PACK OF 10	1
248	9120380	#10-24 X 3/8 ROUND HEAD PHILLIPS MACHINE SCREW - PACK OF 10	1

HANDLE ASSEMBLY

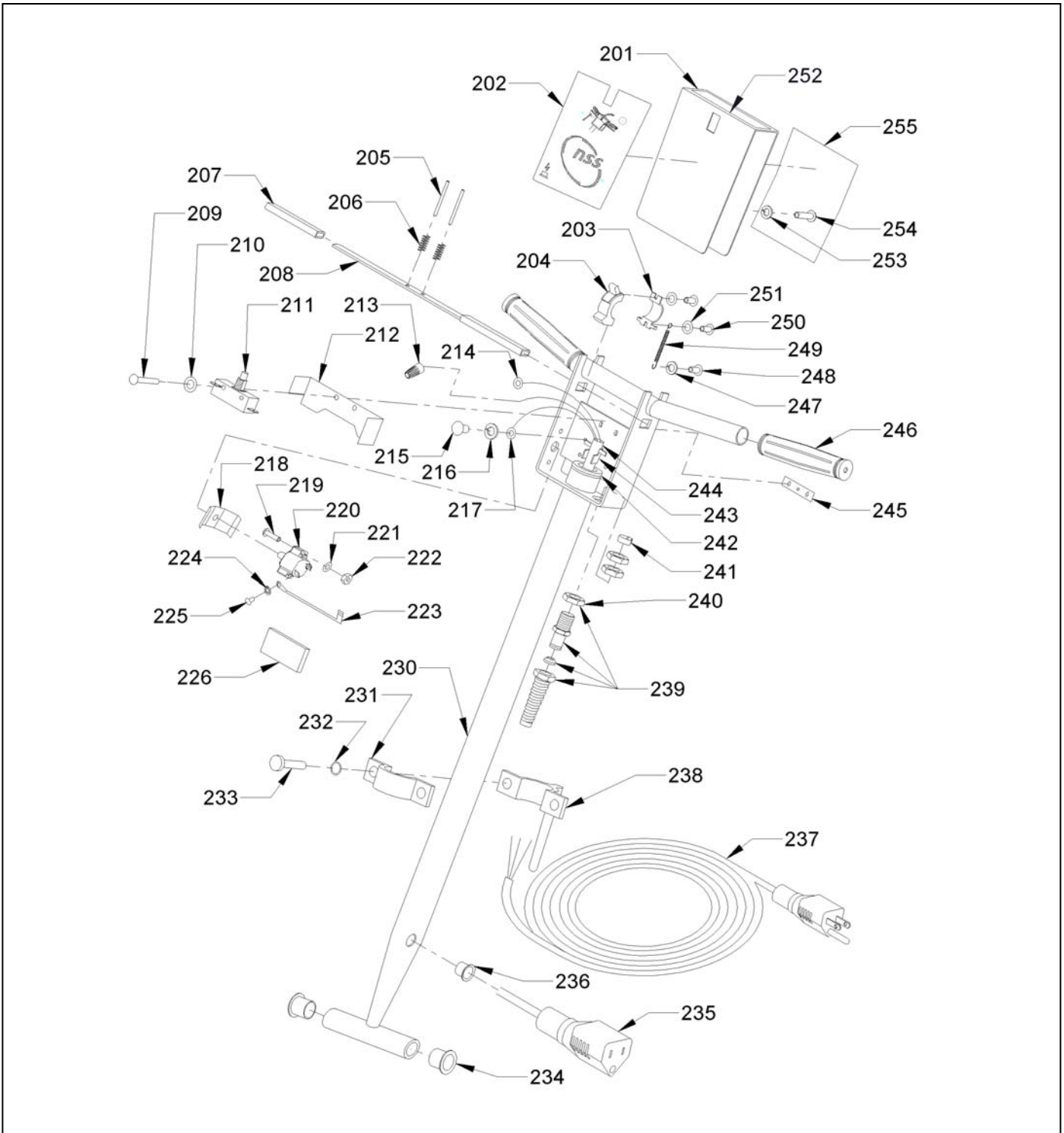

ITEM	PART NO.	DESCRIPTION	QTY
249	0393381	SPRING	1
250	0393881	M3 X .05 X 8mm PAN HEAD PHILLIPS THREAD CUTTING SCREW	2
251	0393841	M3 EXTERNAL STAR LOCK WASHER	2
252	5296471	IDENTIFIER DECAL	1
253	9120320	#10 SPLIT LOCK WASHER - PACK OF 10	2
254	9120430	#10-24 X 3/4 ROUND HEAD PHILLIPS MACHINE SCREW - PACK OF 10	2
255	0190681	SAFETY LABEL	1

UPPER BASE ASSEMBLY

ITEM	PART NO.	DESCRIPTION	QTY
302	5297569	MOTOR COVER ASSEMBLY - INCLUDES:	1
	5297561	MOTOR COVER	1
301	5296401	ELECTRIC CHARGER 2500 LABEL KIT	1
304	8891130	GASKET 1 X 1/8 – NEOPRENE	1
303	0393531	NSS LOGO LABEL	1
305	9120780	#10-32 X 1 1/4 ROUND HEAD SLOT MACHINE SCREW - PACK OF 5	3
306	9120370	7/32 I.D. X 1/2 O.D. X .032/.065 THICK FLAT WASHER #10 - PACK OF 10	3
307	5294706	COVER STAND OFF	1
308	4894461	RUBBER STOP	3
309	5298351	MOTOR - 115 VOLT	1
310	5091691	RUBBER PAD - 1 IN FRONT - 2 ON EACH SIDE IN THE BACK	5
311	5296401	ELECTRIC CHARGER 2500 LABEL KIT	1
312	5296619	CASTER TRIM ASSEMBLY - INCLUDES:	1
	5296081	CASTER TRIM	1
313	9121680	5/16-18 X 1 HEX BOLT - PACK OF 5	2
314	9120380	#10-24 X 3/8 ROUND HEAD PHILLIPS MACHINE SCREW - PACK OF 10	2
315	9120495	#10 INTERNAL STAR LOCK WASHER - PACK OF 10	2
316	5296542	KNOB	1
317	9120850	1/4-20 X 5/16 SET SCREW KNURL POINT - PACK OF 2	1
318	5296573	CASTER BRACKET	1
319	5297826	CASTER STEM	1
320	9121967	7/16 EXTERNAL STAR LOCK WASHER - PACK OF 5	1
321	5296031	CASTER	1
322	9121430	5/16-18 HEX NUT WITH NY-LOK INSERT - THIN - PACK OF 5	2
323	5297513	BASE – SKIRT	1
324	9120850	1/4-20 X 5/16 SET SCREW - KNURL POINT - PACK OF 2	1
325	5296401	ELECTRIC CHARGER 2500 LABEL KIT	1
326	9120827	3/16 SQUARE X 1 LONG KEY - STEEL - PACK OF 2	1
327	3290671	PUSH ON TERMINAL	2
328	9121680	5/16-18 X 1 HEX BOLT - PACK OF 5	1
329	5390043	HANDLE TUBE CLAMP	1
330	5390026	HANDLE BRACE	2
331	9122140	3/8-16 HEX NUT WITH NY-LOK INSERT - PACK OF 5	2
332	5390826	TUBE CLAMP SHOE	1
333	5391891	HANDLE, MAVERICK CE	1
334	5390201	RUBBER TUBING	1
335	0393141	FLATTENED CLAMP BOLT	1
336	0393131	SLOTTED WASHER	1
337	9121420	5/16-18 HEX NUT - PACK OF 10	1
338	0393121	CLAMP LEVER	1
339	0393321	HANDLE GRIP	1
340	5297841	AMP METER WITH HARDWARE	1
341	9120210	#8-32 X 1/4 TRUSS HEAD MACHINE SCREW - PACK OF 10	4

UPPER BASE ASSEMBLY

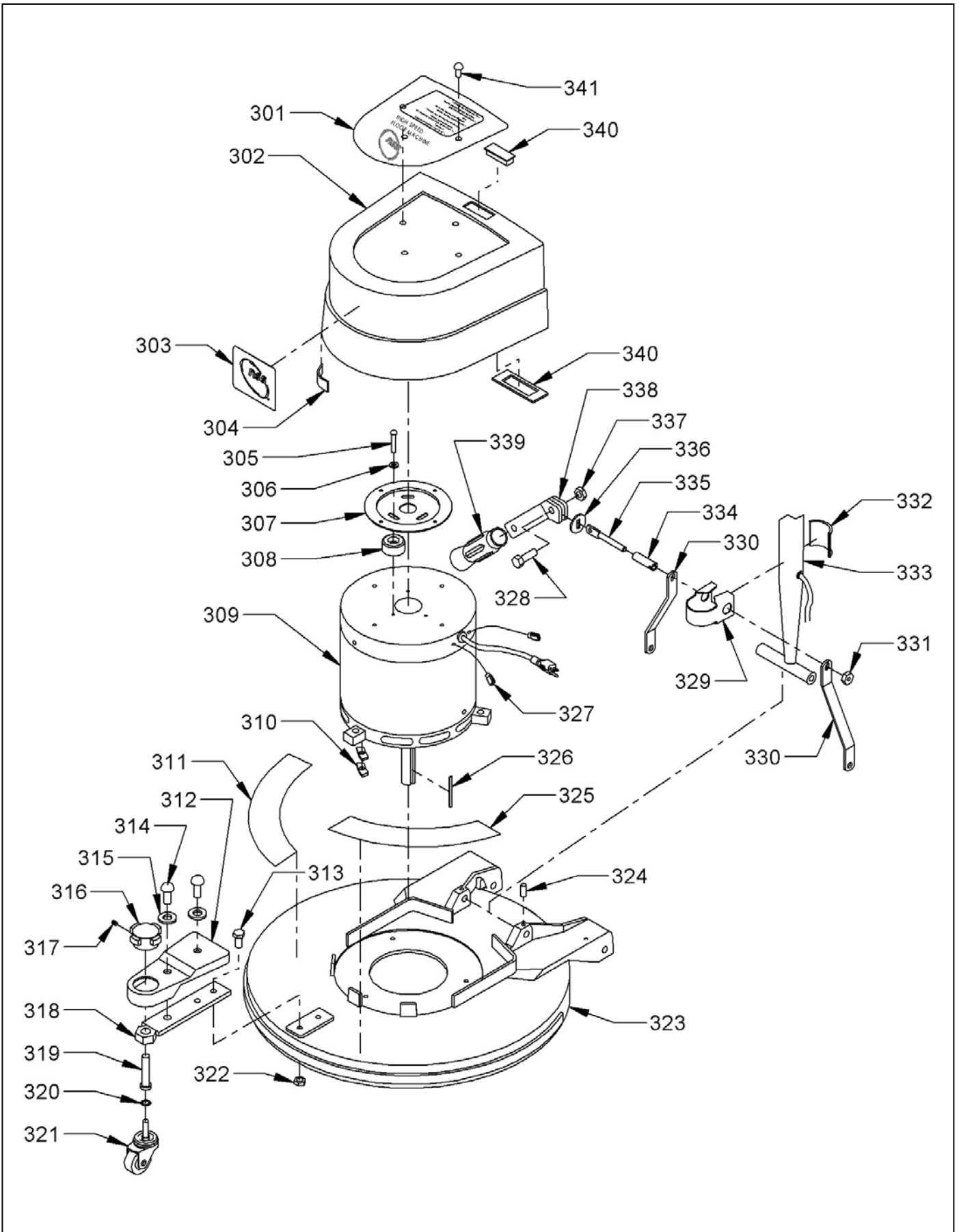

LOWER BASE ASSEMBLY

<u>ITEM</u>	<u>PART NO.</u>	<u>DESCRIPTION</u>	<u>QTY</u>
401	5297513	BASE – SKIRT	1
402	5296619	CASTER TRIM ASSEMBLY - SEE PRIOR PAGE FOR COMPONENT PARTS	1
403	9120950	1/4 X 1 1/4 FENDER WASHER - PACK OF 10	3
404	9120880	1/4 SPLIT LOCK WASHER - PACK OF 10	3
405	9121050	1/4-20 X 1 1/4 SOCKET HEAD CAP SCREW – PACK OF 5	3
406	5294248	FLEXIBLE PAD DRIVER ASSEMBLY	1
407	9123105	3/4 I.D. X 1 1/4 O.D. X .071/.082 THICK FLAT WASHER (11 GA) – PK OF 5	2
408	9121985	13/32 I.D. X 1 O.D. X .12 THICK FLAT WASHER (11 GA) – PACK OF 1	1
409	-----	PAD - SEE ACCESSORIES PAGE FOR OPTIONS	1
410	5990731	SPRING CLIP PAD HOLDER SET - INCLUDES:	1
411	9120506	#8 X 5/8 PAN HEAD SHEET METAL SCREW – PACK OF 5	3
412	9121490	5/16-24 X 7/8 HEX BOLT - PACK OF 2	1
413	9121985	13/32 I.D. X 1 O.D. X .12 THICK FLAT WASHER (11 GA) – PACK OF 1	1
414	5297619	SHROUD ASSEMBLY - INCLUDES:	1
415	5091281	BUMPER - 23 INCH	1
416	9120850	1/4-20 X 5/16 SET SCREW - KNURL POINT - PACK OF 2	2
417	5297556	PIVOT BAR	1
418	9122715	1/2-20 X 5 1/2 HEX BOLT	2
419	9122450	17/32 I.D. X 1 16 O.D. X .074/.121 THICK FLAT WASHER (1/2) - PK OF 5	2
420	5090491	WHEEL LABEL	2
421	5092591	WHEEL - 5" WITH PLASTIC BEARING	2
422	5390811	1/2 I.D. X 1 O.D. X .07 THICK FLAT WASHER – NYLATRON	2
423	9122705	1/2 I.D. X 3/4 O.D. X .01 THICK - 1 WAVE SPRING WASHER (1/2) - PK OF 2	2
424	9122705	1/2 I.D. X 3/4 O.D. X .01 THICK - 1 WAVE SPRING WASHER (1/2) - PK OF 2	2
425	5390026	HANDLE BRACE	2
426	5390811	1/2 I.D. X 1 O.D. X .07 THICK FLAT WASHER – NYLATRON	2
427	9122690	1/2-20 HEX NUT WITH NY-LOK INSERT – THIN – PACK OF 1	2
428	9120850	1/4-20 X 5/16 SET SCREW - KNURL POINT - PACK OF 2	2

LOWER BASE ASSEMBLY

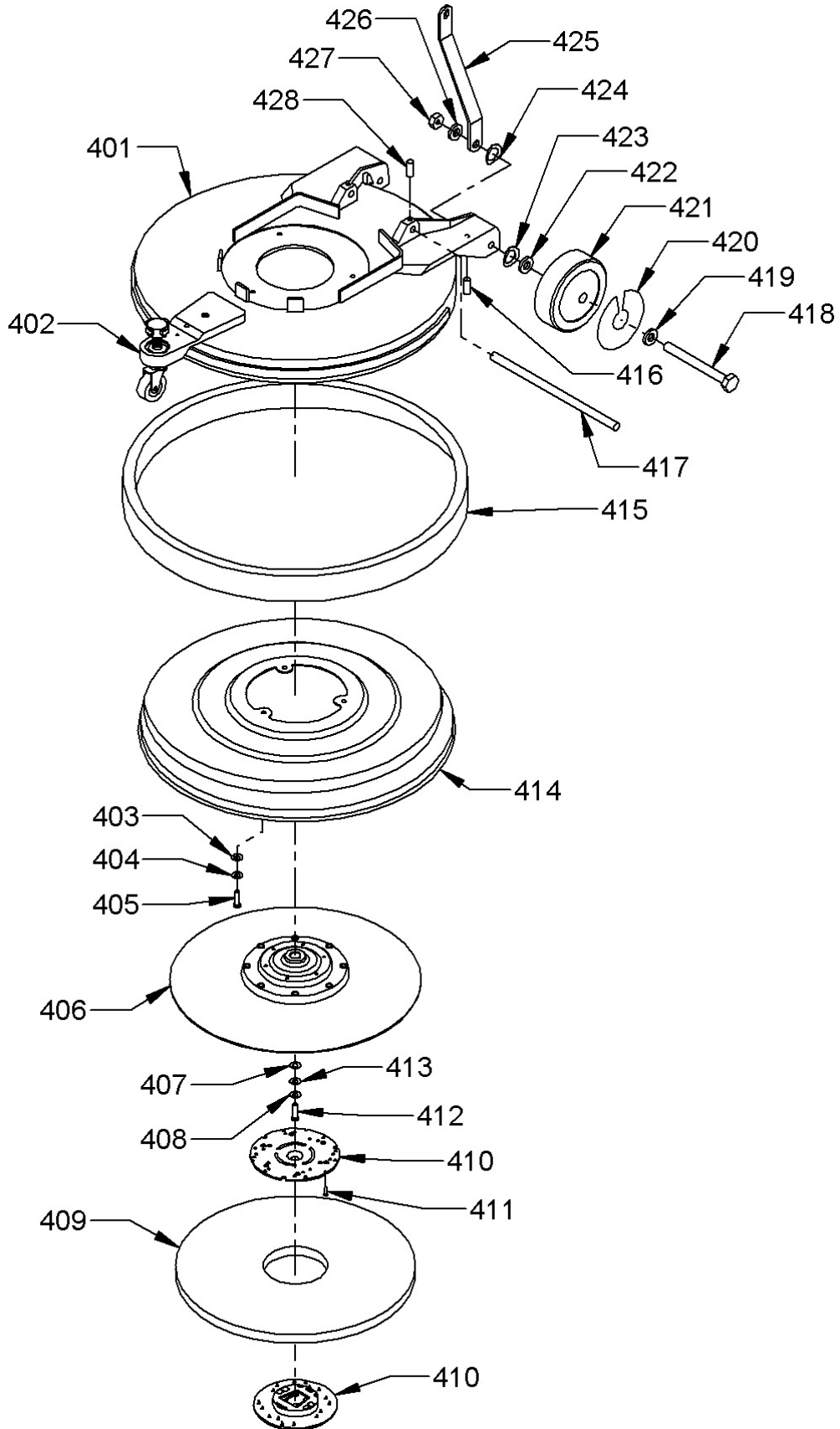

WIRING DIAGRAM

<u>PART NO.</u>	<u>DESCRIPTION</u>	<u>QTY</u>
3290671	PUSH ON TERMINAL	2
5297841	AMP METER WITH HARDWARE	1
5390211	SWITCH	1
5390361	SWITCH INSULATOR	1
5391321	WIRE NUT, ORANGE	1
0294031	# 8 RING TERMINAL 16-14 AWG	1
0298981	# 10 RING TERMINAL 16-14 AWG	1
5490441	BREAKER LEAD – INSULATION	1
5490451	CIRCUIT BREAKER LEAD - 4" WITH TERMINALS	1
5490861	HANDLE CORD	1
5293791	CORD - 75 FEET - 14-3 ST	1
5091569	CORD - 50 FEET WITH TERMINALS – OPTIONAL	1
5091671	STRAIN RELIEF METAL	1
5390261	STRAIN RELIEF NUT	3
5092371	CORD CLAMP, #1002-545 EVERLOCK	1
5095501	CORD CLAMP	1
5298351	MOTOR 115 VOLT 2500	1
5991731	COMMUTATOR BRACKET COVER	1
5298441	COMMUTATOR BRACKET ASSEMBLY WITH BRUSH, BOARD, LEADS	1
5298451	COMMUTATOR BRACKET MACHINED	1
5295071	BRUSH BOARD ASSEMBLY WITH DETECTORS, AND LEADS, INCLUDES:	1
5293651	CARBON BRUSH	4
2797571	BRUSH SPRING	4
9120600	#10-24 X 1/2 SELF TAPPING SCREW – PACK OF 10	5
5991701	THRU BOLT	2
5298501	BRACKET - BOTTOM END	1
5298431	ARMATURE ASSEMBLY WITH BEARINGS - INCLUDES:	1
5991541	BEARING - BOTTOM END	1
9120827	3/16 SQUARE X 1 LONG KEY – PACK OF 2	1
5991551	BEARING - TOP END	1
-----	HELICAL WASHER	1
5991521	STATOR FRAME ASSEMBLY - WITH CLIPS AND MAGNETS	1
5991661	#8-32 X 1.125 MOUNTING SCREW	2
-----	M8 FLAT WASHER – BRASS	2
5492741	RECTIFIER	2
5991681	HEX NUT WITH STAR LOCK WASHER	2
5298461	STRAIN RELIEF	1
5298491	LEAD ASSEMBLY AMP METER	2
5298481	LEAD ASSEMBLY MOTOR CORD	1
5991591	STRAIN RELIEF	1

WIRING DIAGRAM

B - BLACK
W - WHITE
R - RED
Y - YELLOW

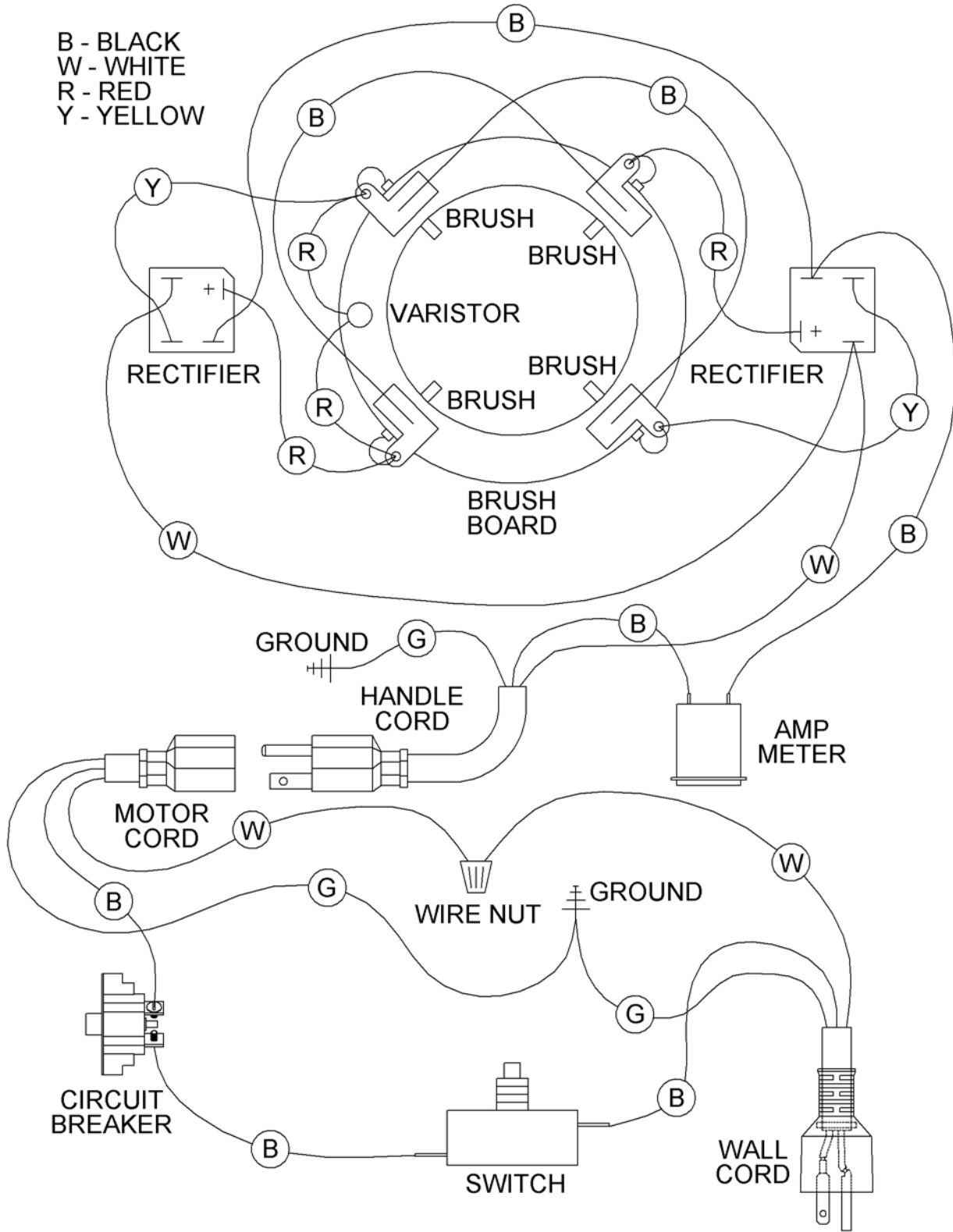

ACCESSORIES



<u>PART NO.</u>	<u>DESCRIPTION</u>
-----------------	--------------------

NOTE:	ALL PADS COME 5 (FIVE) PADS PER CASE
7992051	20" LITE BLUE POLISH / BURNISH PAD - FOR SOFT FINISH
7992061	20" LITE HAIR BURNISH PAD - FOR ALL FINISHES
7992081	20" ULTRA HAIR HARD FINISH PAD - FOR HARD FINISH
7992091	20" ULTIMATE HAIR PAD - HARD FINISH AGGRESSIVE BURNISHING
7992021	20" GREEN SCRUB PAD - HEAVY FINISH REMOVAL
7992001	20" BLACK STRIP PAD - REMOVES FINISH COMPLETELY
7992011	20" BROWN STRIP PAD - REMOVES FINISH COMPLETELY



NSS[®] Enterprises, Inc.

3115 Frenchmens Road
Toledo, Ohio 43607
PHONE (419) 531-2121
FAX (419) 531-3761
mailus@nss.com
www.nss.com