

PARTS LIST
ELECTRIC CHARGER 1500

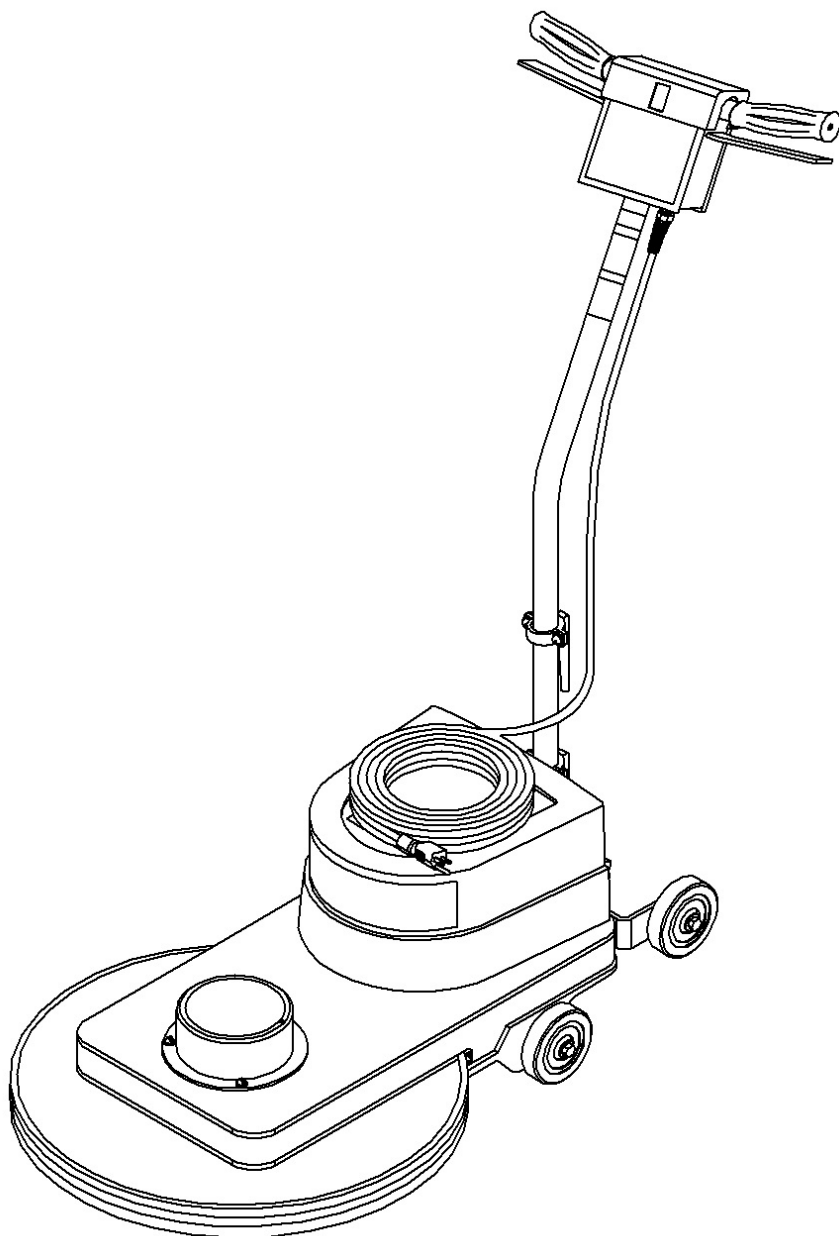

ORIGINAL INSTRUCTIONS



HANDLE ASSEMBLY

<u>ITEM</u>	<u>PART NO.</u>	<u>DESCRIPTION</u>	<u>QTY</u>
	5293999	120V HANDLE ASSEMBLY – 75' CORD	1
	5296609	240V HANDLE ASSEMBLY – 75' SHUKO CORD	1
102	5391873	COVER - SWITCH BOX	1
103	5392421	LABEL - "SWITCH BOX WITH CIRCUIT BREAKER ICON"	1
104	0393511	LOCKOUT BRACKET	1
105	0393521	LOCK OUT	1
106	9120828	1/8 X 1 3/4 ROLL PIN - PACK OF 4	2
107	5390171	SWITCH LEVER SPRING	2
108	5390779	SWITCH LEVER WITH GRIPS - INCLUDES:	1
	0393401	SWITCH LEVER	1
108A	0393411	GRIP - SWITCH LEVER	2
109	5391321	WIRE NUT - ORANGE - 120 VOLT ONLY	1
110	0294031	# 8 RING TERMINAL	1
111	9120100	#6-32 X 1 ROUND HEAD PHILLIPS MACHINE SCREW - PACK OF 10	2
112	9120130	#6 EXTERNAL STAR LOCK WASHER - PACK OF 10	1
113	5390211	SWITCH	1
114	5390361	SWITCH INSULATOR	1
115	9120380	#10-24 X 3/8 ROUND HEAD PHILLIPS MACHINE SCREW - PACK OF 10	1
116	9120320	#10 SPLIT LOCK WASHER - PACK OF 10	1
117	0298981	#10 RING TERMINAL 14-16 AWG	1
121	5490441	INSULATION - BREAKER LEAD	1
122	9120430	#10-24 X 3/4 ROUND HEAD PHILLIPS MACHINE SCREW - PACK OF 10	2
123	5294381	17 1/2 AMP CIRCUIT BREAKER - 120 VOLT	1
	5294581	8 AMP CIRCUIT BREAKER - 240 VOLT	1
124	9120320	#10 SPLIT LOCK WASHER - PACK OF 10	2
125	9120360	#10-24 HEX NUT WITH STAR LOCK WASHER - PACK OF 10	2
126	5490451	CIRCUIT BREAKER LEAD - 4"	1
127	9120200	#8 SPLIT LOCK WASHER - PACK OF 10	2
128	9120223	#8-32 X 1/4 PAN HEAD PHILLIPS MACHINE SCREW - PACK OF 5	2
129	5390511	FOAM PAD	1
130	5296761	HANDLE	1
131	5091636	CORD HOOK CLAMP	1
132	9120880	1/4 SPLIT LOCK WASHER - PACK OF 10	2
133	9121010	1/4-20 X 3/4 TRUSS HEAD PHILLIPS MACHINE SCREW - PACK OF 5	2
134	9120350	#10-24 HEX NUT WITH NY-LOK INSERT - PACK OF 10	1
135	9120615	#10-24 X 3/8 SOCKET HEAD CAP SCREW - PACK OF 10	1
136	5490861	CORD – HANDLE	1
137	5293131	GROMMET	1
138	5091682	CORD HOOK	1
139	5293791	CORD - 75 FEET - 14-3 - 120 VOLT	1
	0299671	CORD - SHUKO - 75 FEET - 16-3 - 240 VOLT	1
	5091569	CORD - 50 FEET - 14-3 - 120 VOLT – OPTIONAL	1
	0396281	TYPE I PLUG POWER CORD (CHINA)	1
140	9120080	#6-32 X 3/4 ROUND HEAD PHILLIPS MACHINE SCREW - 240V ONLY-PK OF 10	1
141	5391931	TERMINAL BLOCK - 240 VOLT ONLY	1
142	5391921	WIRE - GROUND - 240 VOLT ONLY	1
143	5391911	WIRE - DEAD MAN - 240 VOLT ONLY	1
144	5091671	STRAIN RELIEF - 120 VOLT	1
	0299531	STRAIN RELIEF - 240 VOLT	1
145	5390261	STRAIN RELIEF NUT - 120 VOLT	2
	0891131	PLASTIC STRAIN RELIEF NUT - 240 VOLT	1
146	5092371	STRAIN RELIEF CORD CLAMP - 120 VOLT	1
	0299861	STRAIN RELIEF CORD CLAMP - 240 VOLT	1
147	5091656	7/8 I.D. X 1 3/8 O.D. X .112 THICK FLAT WASHER	1
148	5095501	CORD CLAMP	1
149	8791070	3/8 I.D. X 1/2 O.D. VINYL HOSE	4"

HANDLE ASSEMBLY

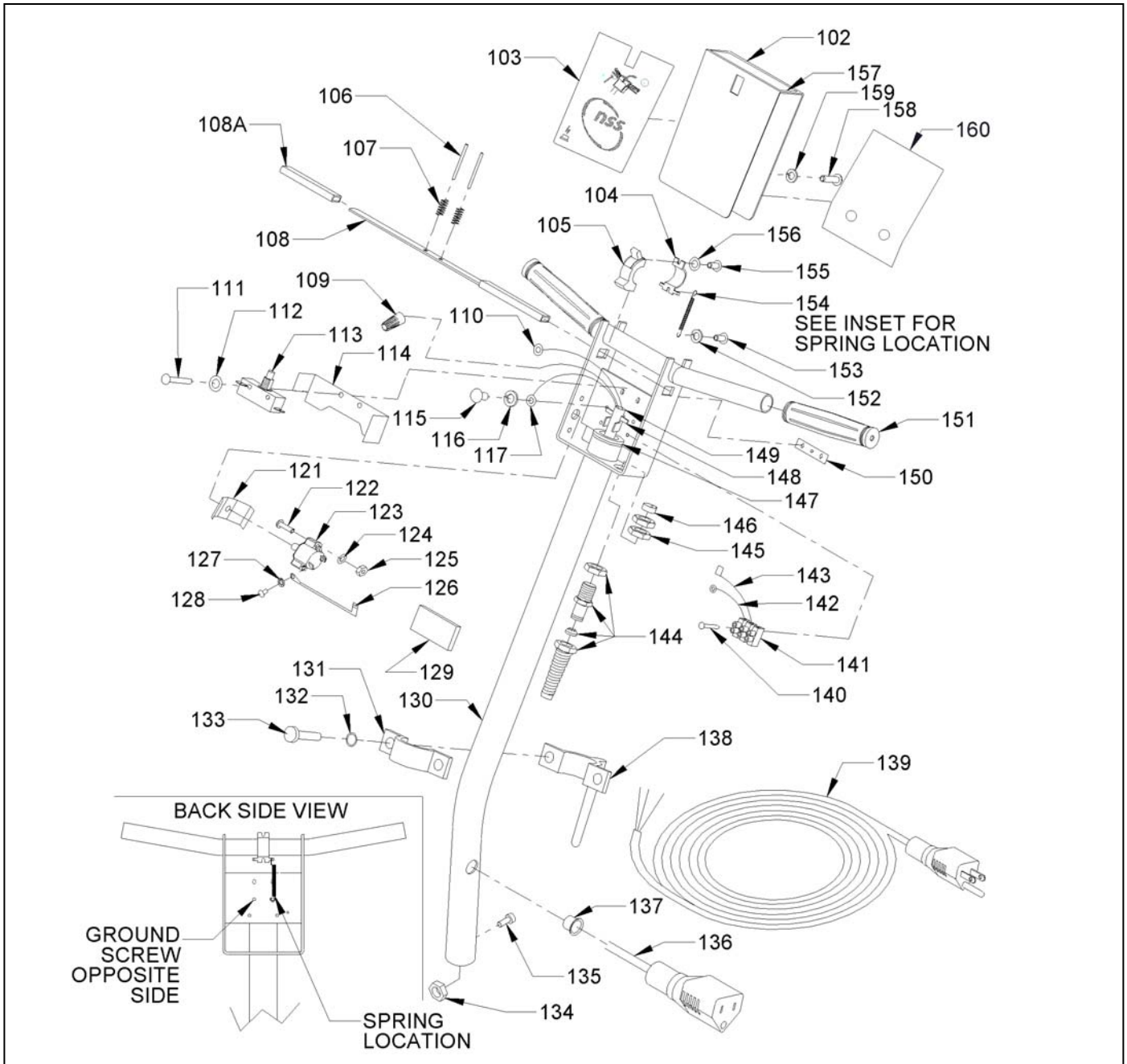

<u>ITEM</u>	<u>PART NO.</u>	<u>DESCRIPTION</u>	<u>QTY</u>
150	9120025	#6-32 DOUBLE HOLE SWITCH SPEED NUT - PACK OF 1	1
151	0393441	HANDLE GRIP	2
152	9120320	#10 SPLIT LOCK WASHER - PACK OF 10	1
153	9120380	#10-24 X 3/8 ROUND HEAD PHILLIPS MACHINE SCREW - PACK OF 10	1
154	0393381	SPRING	1
155	0393881	M3 X .05 X 8mm PAN HEAD PHILLIPS THREAD CUTTING SCREW	2
156	0393841	M3 EXTERNAL STAR LOCK WASHER	2
157	5296461	IDENTIFIER LABEL	1
158	9120320	#10 SPLIT LOCK WASHER	2
159	9120430	#10-24 X 3/4 ROUND HEAD PHILLIPS MACHINE SCREW	2
160	0190681	SAFETY LABEL	1

UPPER BASE ASSEMBLY

ITEM	PART NO.	DESCRIPTION	QTY
201	5296431	LABEL - HANDLE LOCKING INSTRUCTIONS	1
202	9120210	#8-32 X 1/4 TRUSS HEAD MACHINE SCREW - PACK OF 10	4
203	5296421	MOTOR COVER LABEL	1
204	5294291	MOTOR COVER	1
205	0393531	NSS LOGO LABEL - 3 X 12	1
206	5294706	COVER STAND OFF PLATED	1
207	5293571	MOTOR 120 VOLT - 1 1/2 HP - INCLUDES:	1
207A	9120827	3/16 SQUARE X 1 LONG KEY - PACK OF 2	1
207	5298361	MOTOR 240 VOLT - 1 1/2 HP - INCLUDES:	1
207A	9120827	3/16 SQUARE X 1 LONG KEY - PACK OF 2	1
208	9120380	#10-24 X 3/8 ROUND HEAD PHILLIPS MACHINE SCREW - PACK OF 10	3
209	9120320	#10 SPLIT LOCK WASHER - PACK OF 10	3
210	5293103	BEARING COVER	1
211	9121420	5/16-18 HEX NUT - PACK OF 10	4
212	9121520	5/16 SPLIT LOCK WASHER - PACK OF 10	4
213	5294901	PILLOW BLOCK AND BEARING - INCLUDES:	2
213A	5293551	BEARING - REPLACEMENT ONLY	2
214	5293122	BUMPER STRAP	1
215	5293111	BUMPER	1
216	9121800	5/16-18 X 2 HEX BOLT - PACK OF 2	4
217	9120600	#10-24 X 1/2 PAN HEAD PHILLIPS THREAD CUTTING SCREW - PACK OF 10	2
218	9122320	3/8-16 X 1 1/4 SOCKET HEAD CAP SCREW - PACK OF 2	4
219	9122100	3/8 SPLIT LOCK WASHER - PACK OF 10	4
220	9121400	3/8 I.D. X 7/8 O.D. X .064/.104 THICK WROUGHT WASHER (5/16) PACK OF	4
221	9121985	13/32 I.D. X 1 O.D. X .12 THICK FLAT WASHER (11 GAUGE) - PACK OF 1	4
222	9120450	#10-24 X 1 ROUND HEAD PHILLIPS MACHINE SCREW - PACK OF 10	2
223	5293015	DECK	1
224	9120900	1/4-20 HEX NUT WITH NY-LOK INSERT - PACK OF 10	4
225	9122657	1/2-13 X 3 LOCKING HEX BOLT - PACK OF 1	1
226	5293073	HANDLE CASTING	1
227	9121060	1/4-20 X 1 1/4 HEX BOLT - PACK OF 5	4
228	9120850	1/4-20 X 5/16 SET SCREW KNURL POINT - PACK OF 2	2
229	9122450	17/32 I.D. X 1 1/16 O.D. X .074/.121 THICK FLAT WASHER (1/2) - PACK OF 5	1
230	5293272	LOCK HANDLE	1
231	0393321	HANDLE GRIP	1
232	5294491	PULLEY - INCLUDES:	1
232A	9121380	5/16-18 X 3/8 SET SCREW - KNURL - PACK OF 2POINT	1
233	5296761	HANDLE	1
234	9120380	#10-24 X 3/8 ROUND HEAD PHILLIPS MACHINE SCREW - PACK OF 10	1
235	9120320	#10 SPLIT LOCK WASHER - PACK OF 10	1
236	9120370	7/32 I.D. X 1/2 O.D. X .032/.065 THICK FLAT WASHER - PACK OF 10	1
237	5294201	NYLON CABLE CLAMP	1
238	9120740	#10-32 X 3/8 TRUSS HEAD PHILLIPS MACHINE SCREW - PACK OF 10	3

UPPER BASE ASSEMBLY

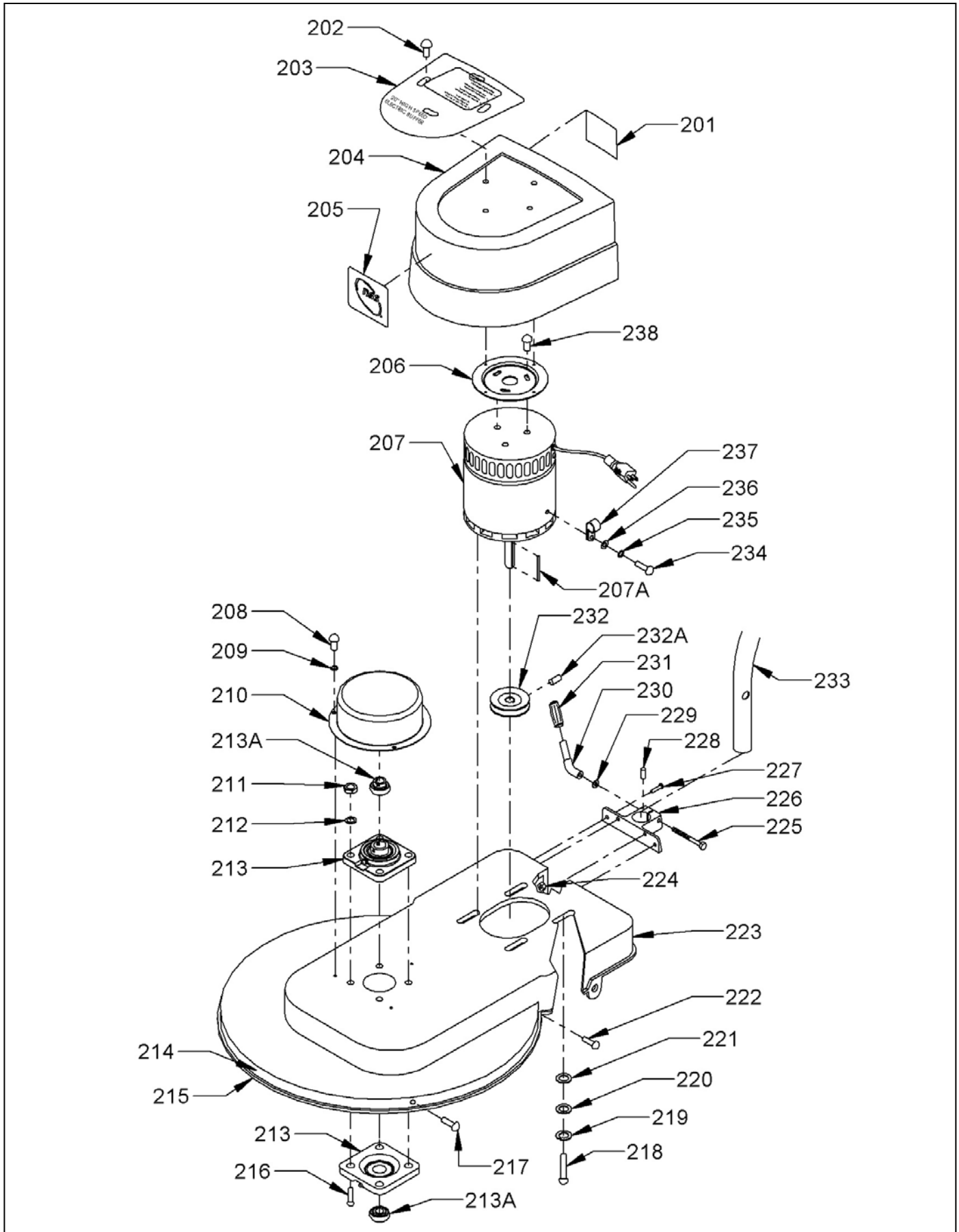

LOWER BASE ASSEMBLY

<u>ITEM</u>	<u>PART NO.</u>	<u>DESCRIPTION</u>	<u>QTY</u>
301	5293015	DECK	1
302	5294901	PILLOW BLOCK AND BEARING - INCLUDES:	2
302A	5293551	BEARING - REPLACEMENT ONLY	2
303	9123105	3/4 I.D. X 1 1/4 O.D. X .071/.083 THICK FLAT WASHER (11 GAUGE) - PK OF 1	1
304	5293151	RETAINING RING	1
305	9123105	3/4 I.D. X 1 1/4 O.D. X .071/.083 THICK FLAT WASHER (11 GAUGE) - PK OF 1	1
306	5293532	SHAFT	1
307	9122507	1/2-13 HEX NUT WITH NY-LOK INSERT - PACK OF 1	1
308	5294501	BELT	1
309	5293059	PULLEY - INCLUDES:	1
309A	9121043	1/4 X 1 1/8 ROLL PIN - PACK OF 5	4
310	5294339	PAD DRIVER - INCLUDES:	1
310A	5293043	PAD DRIVER PLATE	1
311	— — — —	PAD - SEE ACCESSORIES PAGE FOR DIFFERENT TYPES	1
312	5294151	PAD HOLDER CUP	1
313	9122507	1/2-13 HEX NUT WITH NY-LOK INSERT - PACK OF 1	1
314	5294239	PAD HOLDER COMPLETE ASSEMBLY - INCLUDES:	1
314A	5294219	PAD HOLDER BRACKET WITH TWIST FASTENERS - INCLUDES:	1
314A1	5294216	PAD HOLDER BRACKET	1
314A2	5294219	TWIST FASTENER	2
314A3	9120313	9/32 X 1/32 FLAT HEAD RIVET - PACK OF 5	4
315	9122470	9/16 I.D. X 1 3/8 O.D. X .086/.132 THICK WROUGHT WASHER (1/2) - PK OF 2	1
316	9120320	#10 SPLIT LOCK WASHER - PACK OF 10	8
317	9120770	#10-32 X 5/8 ROUND HEAD PHILLIPS MACHINE SCREW - PACK OF 10	8
318	9122470	9/16 I.D. X 1 3/8 O.D. X .086/.132 THICK WROUGHT WASHER (1/2) - PK OF 2	1
319	9120013	3/16 X 1/2 WOODRUFF KEY - STEEL - PACK OF 2	1
320	9121800	5/16-18 X 2 HEX BOLT - PACK OF 2	4
321	9122465	.516 I.D. X .813 O.D. X .027/.030 THICK FLAT WASHER - PACK OF 2	2
322	9122685	1/2 X 2 7/8 CLEVIS PIN - PACK OF 1	2
323	9120312	1/8 X 1 HUMPED COTTER PIN - PACK OF 5	2
324	5090491	WHEEL LABEL	2
325	5092591	WHEEL - 5" - WITH PLASTIC BEARING	2
326	9122465	.516 I.D. X .813 O.D. X .027/.030 THICK FLAT WASHER - PACK OF 2	2
327	9120850	1/4-20 X 5/16 SET SCREW KNURL POINT - PACK OF 2	2

LOWER BASE ASSEMBLY

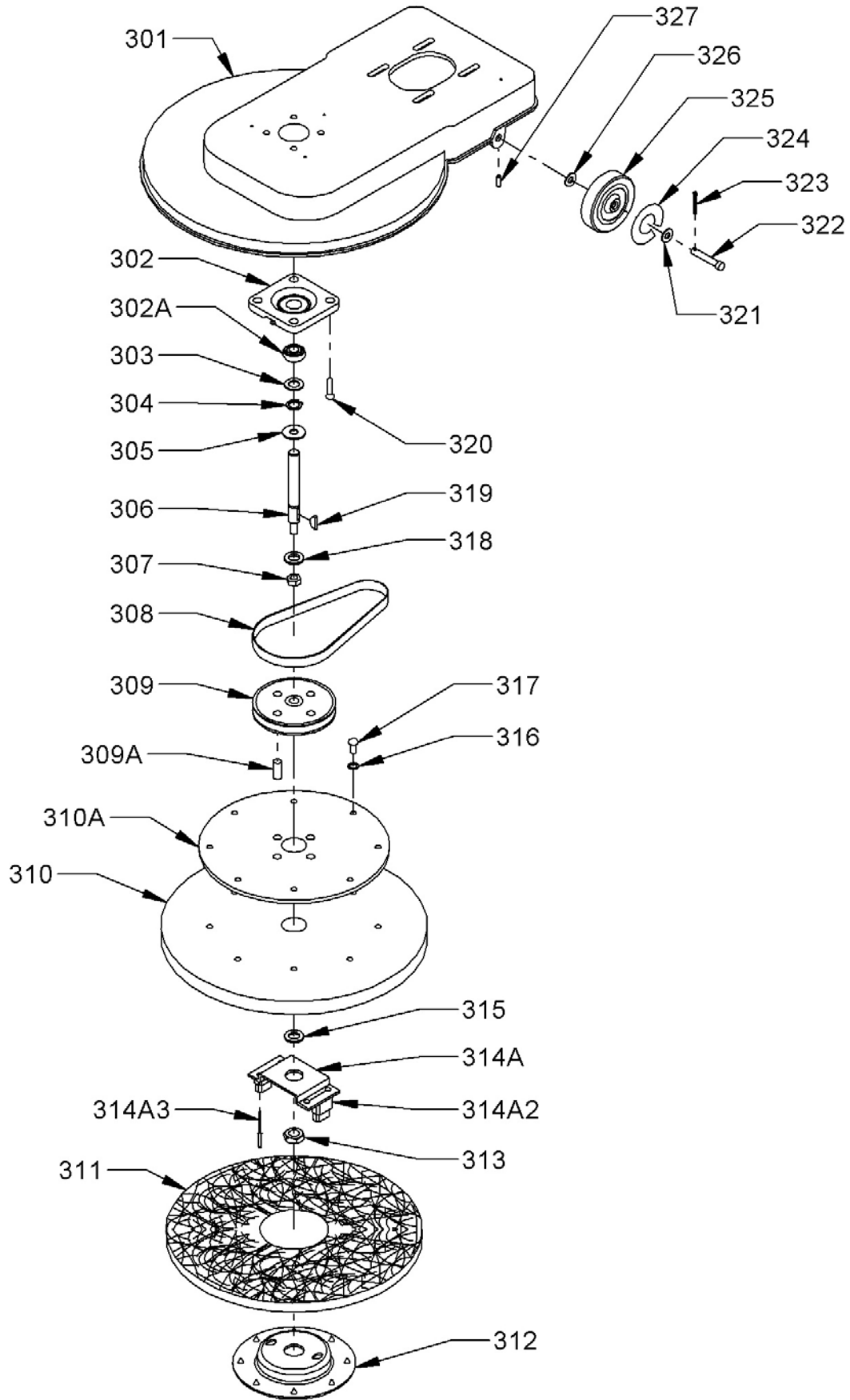

MOTOR ASSEMBLY

<u>ITEM</u>	<u>PART NO.</u>	<u>DESCRIPTION</u>	<u>QTY</u>
120 VOLT MOTOR ASSEMBLY			
	5293571	MOTOR ASSEMBLY, 120V, 1 1/2 HP	1
401	5991731	COMMUTATOR BRACKET COVER	1
402	5295051	COMMUTATOR BRACKET ASSEMBLY WITH BRUSH, BOARD, LEADS-INCLUDES:	1
	5295061	COMMUTATOR BRACKET	1
401A	5295071	BRUSH BOARD ASSEMBLY WITH DETECTORS, AND LEADS, INCLUDES:	1
401A1	5293651	CARBON BRUSH	4
401A2	2797571	BRUSH SPRING	4
403	5991701	THRU BOLT	2
404	9120600	#10-24 X 1/2 SELF TAPPING SCREW	5
405	5295081	BRACKET - BOTTOM END	1
406	5293591	ARMATURE ASSEMBLY INCLUDES:	1
406A	5991541	BEARING - BOTTOM END	1
406B	9120827	SHAFT KEY	1
406C	5991551	BEARING - TOP END	1
407	-----	HELICAL WASHER	1
408	5991521	STATOR FRAME ASSEMBLY - WITH CLIPS AND MAGNETS	1
409	5991661	#8-32 X 1.125 MOUNTING SCREW	2
410	-----	M8 FLAT WASHER – BRASS	2
411	5492741	RECTIFIER	2
412	5991681	HEX NUT WITH STAR LOCK WASHER	2
413	5295091	MOTOR CORD	1
414	5991591	STRAIN RELIEF	1
240 VOLT MOTOR ASSEMBLY			
	5298361	MOTOR ASSEMBLY, 240V, 1 1/2 HP	1
401	5991731	COMMUTATOR BRACKET COVER	1
402	5991821	COMMUTATOR BRACKET ASSEMBLY WITH BRUSH, BOARD, LEADS - INCLUDES:	1
	5295061	COMMUTATOR BRACKET	1
401A	5991831	BRUSH BOARD ASSEMBLY WITH DETECTORS, AND LEADS, INCLUDES:	1
401A1	5991861	CARBON BRUSH	4
401A2	2797571	BRUSH SPRING	4
403	5991701	THRU BOLT	2
404	9120600	#10-24 X 1/2 SELF TAPPING SCREW	5
405	5295081	BRACKET - BOTTOM END	1
406	5991811	ARMATURE ASSEMBLY INCLUDES:	1
406A	5991541	BEARING - BOTTOM END	1
406B	9120827	SHAFT KEY	1
406C	5991551	BEARING - TOP END	1
407	-----	HELICAL WASHER	1
408	5991521	STATOR FRAME ASSEMBLY - WITH CLIPS AND MAGNETS	1
409	5991661	#8-32 X 1.125 MOUNTING SCREW	2
410	-----	M8 FLAT WASHER – BRASS	2
411	5992121	RECTIFIER	2
412	5991681	HEX NUT WITH STAR LOCK WASHER	2
413	5295091	MOTOR CORD	1
414	5991591	STRAIN RELIEF	1

MOTOR ASSEMBLY

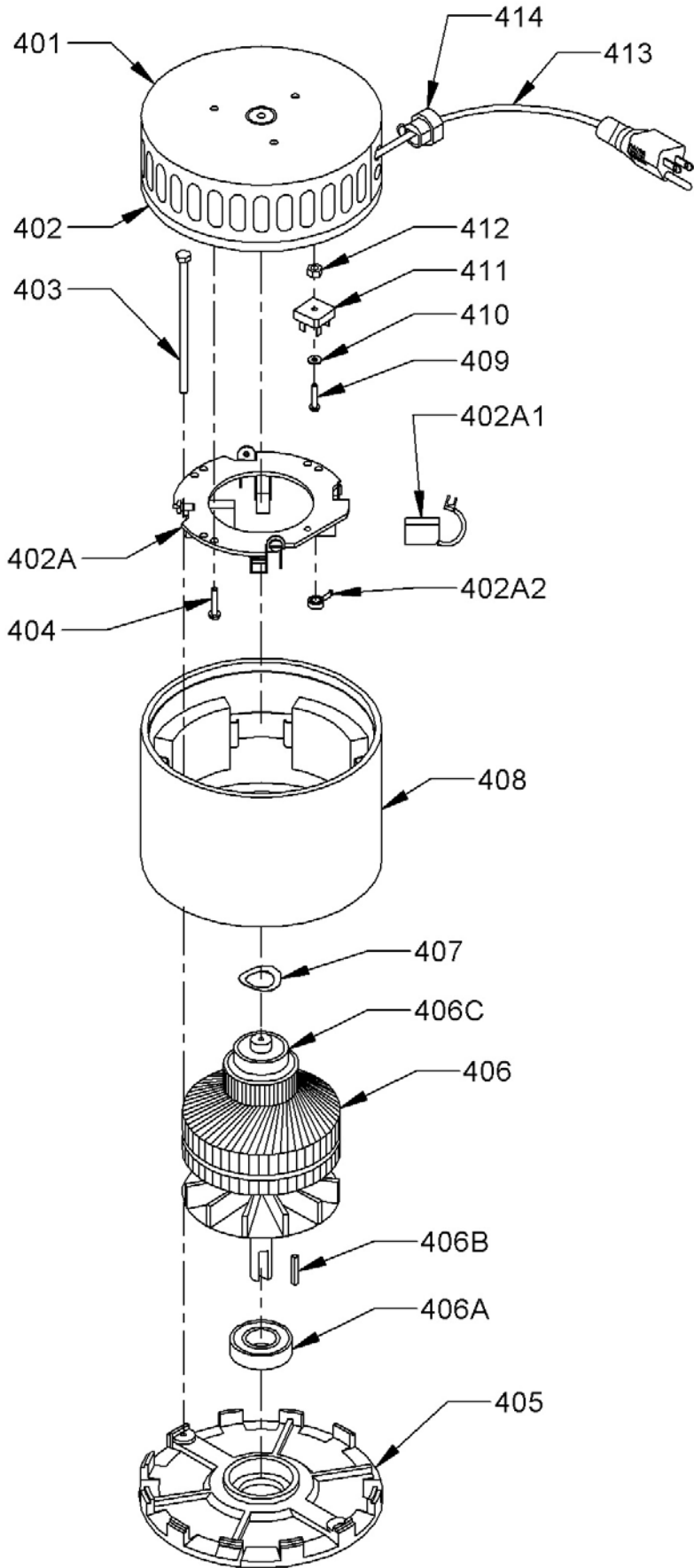

OPTIONAL WHEEL CARRIAGE ASSEMBLY

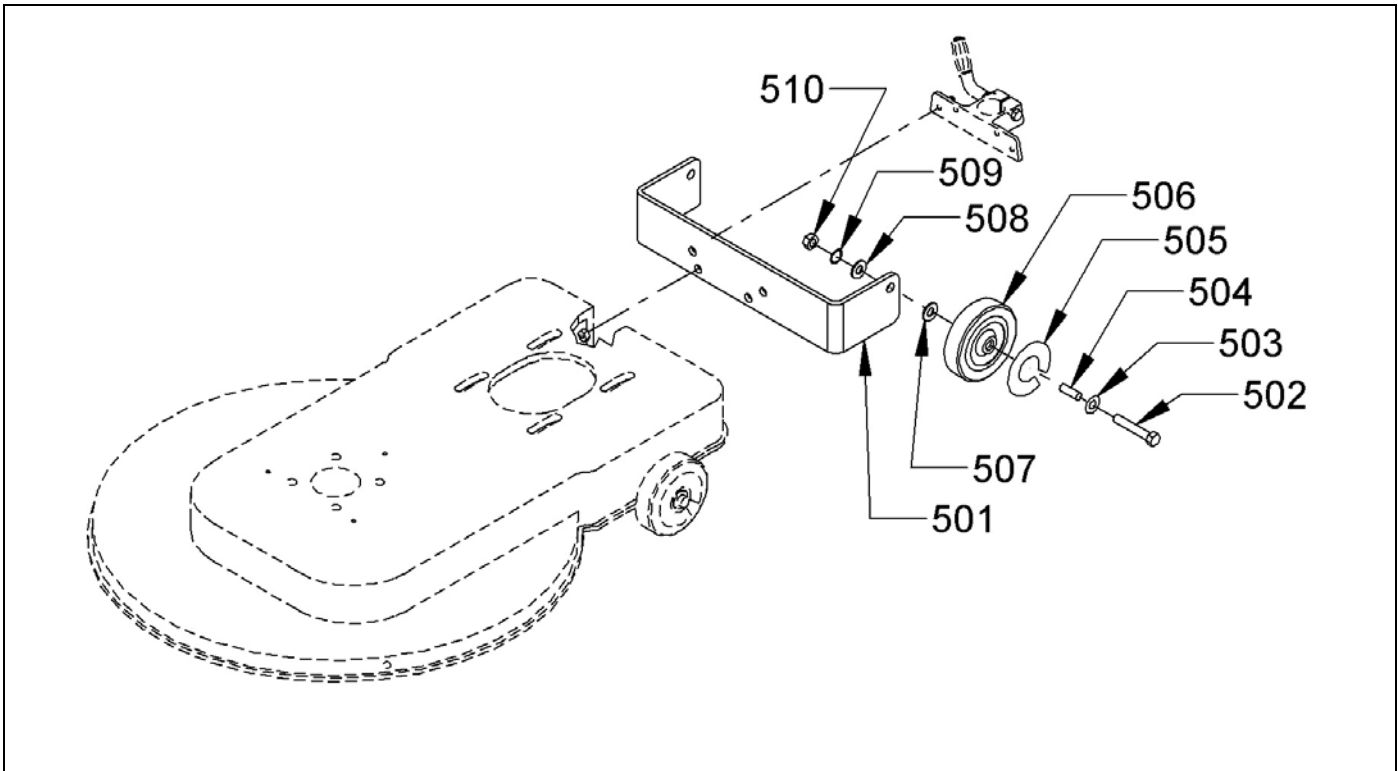

<u>ITEM</u>	<u>PART NO.</u>	<u>DESCRIPTION</u>	<u>QTY</u>
	5294449	WHEEL CARRIAGE ASSEMBLY	1
501	5294443	WHEEL BRACKET	1
502	9122080	3/8-16 X 2 1/2 HEX BOLT	2
503	9122705	1/2 I.D. X 3/4 O.D. X .01 THICK - 1 WAVE SPRING WASHER (1/2) - PACK OF 2	2
504	5294391	SPACER	2
505	5090491	WHEEL LABEL	2
506	5092591	WHEEL 5" WITH PLASTIC BEARING	2
507	9122705	1/2 I.D. X 3/4 O.D. X .01 THICK - 1 WAVE SPRING WASHER (1/2) - PACK OF 2	2
508	9122180	13/32 I.D. X 13/16 O.D. X .051/.080 THK WROUGHT WASHER (3/8)-PK 10	2
509	9122100	3/8 SPLIT LOCK WASHER - PACK OF 10	2
510	9122000	3/8-16 HEX NUT - PACK OF 10	2

WIRING DIAGRAM

WIRE DIAGRAM - 120 VOLT

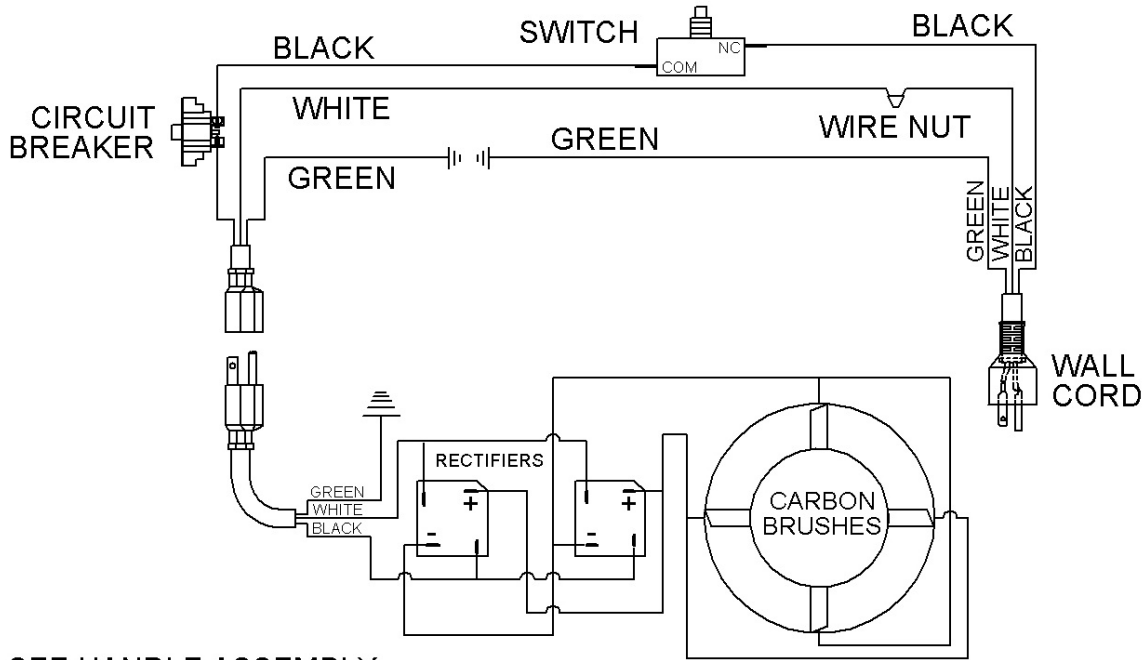

SEE HANDLE ASSEMBLY
FOR COMPONENT NUMBERS

WIRE DIAGRAM - 240 VOLT

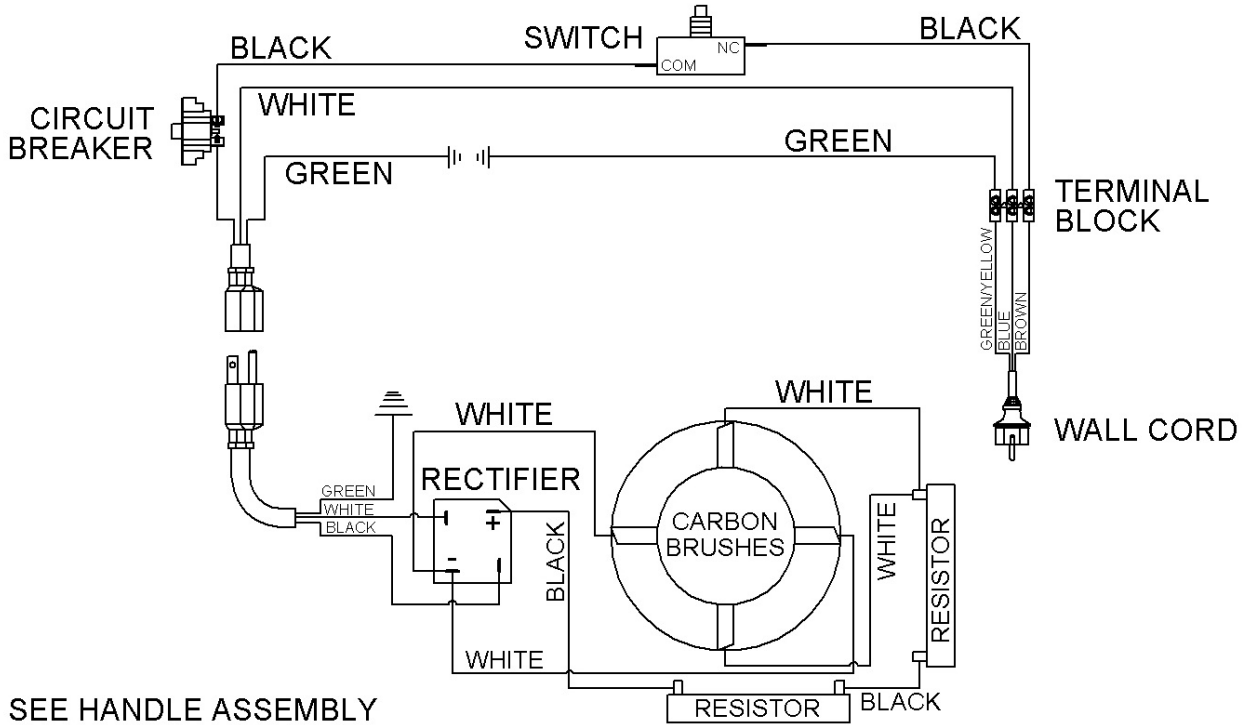

SEE HANDLE ASSEMBLY
FOR COMPONENT NUMBERS

ACCESSORIES



<u>PART NO.</u>	<u>PART DESCRIPTION</u>
-----------------	-------------------------

NOTE:	ALL PADS COME 5 PADS PER CASE (EXCEPT TWISTER PADS)
7992051	20" LITE BLUE POLISH / BURNISH PAD - FOR SOFT FINISH
7992061	20" LITE HAIR BURNISH PAD - FOR ALL FINISHES
7992081	20" ULTRA HAIR HARD FINISH PAD - FOR HARD FINISH
7992091	20" ULTIMATE HAIR PAD - HARD FINISH AGGRESSIVE BURNISHING
7992021	20" GREEN SCRUB PAD - HEAVY FINISH REMOVAL
7992001	20" BLACK STRIP PAD - REMOVES FINISH COMPLETELY
7992011	20" BROWN STRIP PAD - REMOVES FINISH COMPLETELY

<u>TWISTER PADS</u>	
---------------------	--

7992141	20" TWISTER RED PAD
7992131	20" TWISTER WHITE PAD
7992121	20" TWISTER YELLOW PAD
7992101	20" TWISTER GREEN PAD



NSS® Enterprises, Inc.

3115 Frenchmens Road
Toledo, Ohio 43607
PHONE (419) 531-2121
FAX (419) 531-3761
mailus@nss.com
www.nss.com