

Charger AB (Pad Assist)

IMPORTANT SAFETY INSTRUCTIONS



WARNING: Failure to observe these instructions can cause personal injury to machine operator or bystanders.



WARNING: Fire or explosion hazard. **NEVER** operate this machine in an explosive atmosphere (grain dust, flammable liquids or fumes, etc.).



WARNING: Fire or explosion hazard. **NEVER** use flammable liquids (gas, kerosene, solvents, or thinners) to clean or burnish floor.

INTENDED USE

NSS Burnishers are intended for commercial use, buffing and burnishing floors in an indoor environment. It is not intended for spray burnishing. NSS does not recommend using these machines for any other purpose.

FOR SAFETY

- **ALWAYS** read and understand all instructions before operating or servicing machine.
- **ALWAYS** use this machine **ONLY** as described in this manual.
- **NEVER** attempt to operate this machine unless you have been trained in its operation.
- **NEVER** allow an untrained person to operate this machine.
- **ALWAYS** operate this machine from the rear control panel, not from the side.
- **ALWAYS** turn off master switch when attaching or changing pads.
- **NEVER** attempt to operate this machine if it is not working properly or has been damaged in any manner.
- **NEVER** disconnect or modify any switches or safety devices (circuit breaker).
- **NEVER** drop or insert any object into any machine opening.
- **NEVER** operate this machine with any air opening blocked. Keep all air openings free of dust, lint, hair, etc.
- **NEVER** pick up anything that is burning or smoking, such as cigarettes, matches or hot ashes.

- **NEVER** allow this machine to be used as a toy. Close attention is necessary when used by or near children.
- **ALWAYS** wear clean tennis shoes or "non-slip" shoes. Leather soled shoes will be extremely slippery.
- **ALWAYS** keep face, fingers, hair or any other body part or loose clothing away from any machine opening or moving part (revolving pad driver).
- **ALWAYS** be sure that the ramp is secured to the vehicle before attempting to load / unload.
- **ALWAYS** use extreme caution when operating the machine on a ramp or loading / unloading this machine into or out of a truck / trailer. Use extreme caution if the ramp is wet, oily, or covered with cleaning chemicals.
- **NEVER** stop or turn the machine on a ramp or incline.
- **NEVER** attempt to climb a grade or operate this machine on a ramp or incline of more than 20 degrees.
- **ALWAYS** store this machine indoors in a dry, cool area.
- **NEVER** park or store the machine near a dock, on ramps, near a furnace, boiler, open flame, or other high heat source.
- **NEVER** spray this machine with water or any liquids.
- **NEVER** allow the vacuum motor or battery charging plug to get wet or a short may occur.
- **NEVER** operate this machine when the battery charger is plugged in.
- **NEVER** operate the machine outdoors or allow machine to freeze.
- **NEVER** expose the machine to rain, snow, or extreme temperatures.
- **NEVER** store any items on the machine.

ALL REPAIR SERVICE MUST BE PERFORMED BY AN NSS AUTHORIZED DISTRIBUTOR / SERVICE STATION USING ONLY NSS ORIGINAL EQUIPMENT PARTS.

SAVE THESE INSTRUCTIONS



IMPORTANT SAFETY INSTRUCTIONS

BATTERY POWERED EQUIPMENT WITH ON BOARD CHARGERS



WARNING: Failure to observe these instructions can cause personal injury to machine operator or bystanders.

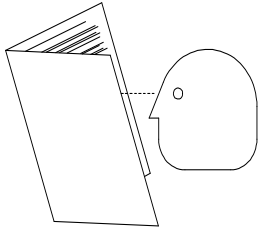

Read and understand all instructions before installing or charging batteries.

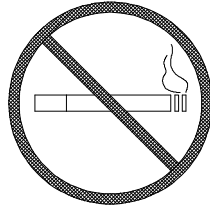

No smoking, open flames, or sparks while working with batteries.

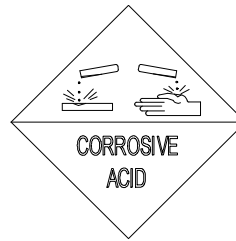

Contains acid. Avoid contact

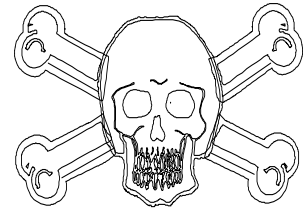

Poison. Causes severe burns. Avoid contact.

WARNING: Batteries emit hydrogen, which can cause fire or explosion.

NEVER smoke, light a match, or cause a spark during operation or charging.

ALWAYS charge in a well-ventilated area away from open flame.

GENERAL

- **ALWAYS** read and understand all instructions before installing or charging batteries.
- **NEVER** attempt to install or charge batteries unless you have been trained to do so.
- **NEVER** allow an untrained person to install or charge batteries.
- **ALWAYS** remove all jewelry when working on or near the batteries.
- **ALWAYS** turn off all switches during installation and service.
- **ALWAYS** disconnect the battery leads before performing any service or repair.
- **ALWAYS** wear eye protection and protective clothing to avoid contact with battery acid.
- **NEVER** lay anything on top of batteries as arcing may occur.
- **IF CONTACT WITH BATTERY ACID OCCURS**, follow these instructions:
 - SKIN – rinse area with water.
 - EYES – Flush with water for 15 minutes.
 - INTERNAL – Drink water or milk. Follow with Milk of Magnesia, beaten egg or vegetable oil. Call a physician immediately.

BATTERY INSTALLATION

- **ALWAYS** use two people to install, as batteries are heavy.
- **ALWAYS** turn off all machine switches.
- **ALWAYS** position batteries as shown on the machine installation decal to maintain machine balance.
- **ALWAYS** connect batteries as shown on the machine installation decal to avoid shorting out the batteries and the electrical system.

BATTERY CHARGING

- **ALWAYS** read instructions on charger carefully.
- **ALWAYS** use the NSS supplied charger with proper voltage rating.

For lead acid batteries only, (does not apply to gel cell or maintenance free batteries).

- **ALWAYS** check to ensure the battery water level covers the battery plates before charging.
- **ALWAYS** check water level after charging and add water if necessary to bring level to the bottom of the fill hole.
- **NEVER** overfill batteries as battery and machine damage may result.
- **ALWAYS** wipe any acid from the top of batteries using a soap solution.
- **ALWAYS** study battery manufacturers' specific precautions such as recommended rates of charge.
- **ALWAYS** reattach caps to batteries. Do not charge with caps loose or removed.
- **ADD** only distilled or treated city water. Not well water.
- **NEVER** charge a frozen battery.
- **ALWAYS** plug the charger into an earthed socket-outlet.
- **NEVER** touch uninsulated portion of output connector or uninsulated battery terminal.
- **ALWAYS** disconnect the AC supply before making or breaking the connections to the battery while charging.
- **NEVER** open or disassemble charger.
- **NEVER** operate charger if the AC supply cord is damaged or if the charger has received a sharp blow, been dropped, or otherwise damaged in any way.

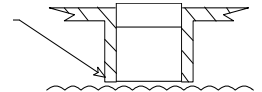

ALL REPAIR SERVICE MUST BE PERFORMED BY AN NSS AUTHORIZED DISTRIBUTOR/ SERVICE STATION USING ONLY NSS ORIGINAL EQUIPMENT PARTS

NOISE AND VIBRATION

NOISE

Sound pressure level at Operator position 71 dB(A)

VIBRATION

Weighted RMS acceleration value (ISO 5349) .316 m/s²

MACHINE INSPECTION

- Now that the machine is unpacked remember to recycle all packing materials.
- Inspect the machine for damage or missing components. If damage is found, contact the local freight company to file a freight claim.

MACHINE COMPONENTS

Housing

The housing protects both the batteries and the internal components. It is made of durable Polyethylene.

Pad Pressure Knob

Located in the middle of the control panel at the upper most point. Turning this knob controls the pressure the pad exerts on the floor.

Operator Control Panel

The operator control panel is located at the upper rear area of the machine. This panel has components that control various machine functions.

- The toggle switch on the left side of the panel turns the unit on and off.
- The light in the center, when lit up, indicates the unit is turned on.

Circuit Breaker (s)

Located on the right side of the rear panel is the circuit breaker. If this is a VS model there will be two circuit breakers.

- Too much pad pressure may cause the circuit breaker(s) to disconnect the circuit to the motor.
- If this happens, reduce the pad pressure, push the black button, and continue running the machine.

Battery Meter

The battery meter is located on the left side of the operator control panel and shows the state of charge of batteries during operation and recharge.

- Work Range - This is the green area in the middle of the meter. It shows the approximate amount of "power" available in the batteries. Observe this reading when operating this machine.
- Recharge Range - This is the red area on the left of the meter. It shows when the batteries need to be recharged. Continued machine operation in this area will cause battery damage and potential machine damage.

Dead Man Lever

This bar is located just under the handle. When squeezed it activates the pad driving motor. It is not functional in the pad changing or transport positions.

AMP Meter

- The AMP meter is located on the right side of the control panel and is a visual indication of the amount of pad pressure.
- The pad is adjusted properly when the needle on the AMP meter, on average stays in the green area indicating proper machine use.

Battery Charging

- To charge the batteries plug the charger cord, located at the rear of the machine, into an electrical outlet.
- When the cord is plugged into an outlet the machine is currently disabled.
- See charging instructions for more details.

Release Knob

- Located in the center of the back panel, this knob is used to adjust the positions of the machine. Lifting the knob releases the machine allowing it to tip back raise the pad off of the floor.
- The machine is in the operating position when the Operation handle is at its highest level.
- The machine is in the transport position when the Operation handle is in the center position.
- The machine is in the pad changing position when the Operation handle is at its lowest level.

Battery Compartment Drain Plug

This plug is located on the left and right side of the machine inside the rear panel. Spilled liquids from the battery compartment area are collected here. Remove the plug to drain, disposed of all liquids according to your local EPA regulations.

Flexiwall Shield

The Flexiwall shield creates a seal with the floor to contain and collect any dust created by the burnishing operation.

Brush Motor

This machine has a 36-volt brush motor located at the front of the machine.

- The Charger 2025 AB utilizes a 2.5 HP (1.8 KW.) permanent magnet motor to drive the 20" (51cm.) pad.
- The Charger 2716 AB utilizes a 3 HP (2.2 KW.) permanent magnet motor to drive the 27" (69cm) pad.
- These motors have carbon brushes that must be serviced on a regular basis.
- Refer to the maintenance section later in this book.

Battery Packages

- These machines utilize a 36-volt system, and are available with three (3) 12-volt, 210-Amp Hour Batteries.
- Consult your local NSS authorized distributor for application recommendations.
- Do not substitute smaller or larger batteries, as the balance of the machine will be affected.

MACHINE OPERATION

General Information

This machine works best with dry polishing or burnishing. Use mop on restorers rather than spray buff systems to restore the shine.

Spray buffing is time consuming, uses more pads because they become loaded with floor finish, and can cause overloading of the machine's circuit breaker.

Preparing the Machine for use

Install the batteries:

- Always wear protective glasses and clothing when handling batteries.
- See Battery Warnings on page 2.
- Turn off all switches, unlatch the clasps and slide the housing forward to expose the battery compartment.
- Batteries are heavy - use two people to install.
- Refer to wiring diagram inside the battery compartment. Align batteries in compartment as shown on diagram.
- Install battery cables as shown on wiring diagram.
- Tighten bolts and hex nuts with a wrench.

Caution: Do not short across two terminals with a wrench.

Caution: Loose or improper battery connections will cause battery or machine damage and possible personal injury.

- Install terminal boots over terminals to complete installation.

Check the Battery Charge

Turn the switch to the "I" position. Check to see that the indicator light is on. With master switch on, check battery meter for charge indication.

- When the needle is in the red area on the left side, marked "recharge", the batteries are too low to operate and should be recharged.
- When the needle is in the green area, the batteries are within the high to low working range.
- When the needle is in the red area on the right side of the gauge it indicates the level of battery charge while connected to the charger.

- When needle is in the far right, red area, shown as high, and the automatic charger has shut off, charging of the batteries is complete.

Pad Installation / Changing

Lower the back of the machine to Position 3 (see bottom figure on page 4), by lifting up on the release knob with one hand, and with your other hand on the operator handle, gently lower the back of the machine until it rest on the floor.

- Make sure that the correct pad (7/8" to 1") X 20" is being installed.
- Place the pad flat on the floor, and remove the center hole of the pad, step on the center of the pad to compress the edges around the center hole. This will allow easier installation of the pad holding cup.
- With the machine in the pad changing position, carefully center the pad on the driver.

Caution: Pads must be installed concentric (evenly aligned) with the outside edge of the pad driver. Failure to follow these precautions will cause excessive machine vibration, a reduction in pad life and produce unsatisfactory burnishing results.

- Place the pad grabber in the center hole of the pad.
- Holding the pad driver and pad, push upward on the pad grabber until the spring clip has clicked twice.

Caution: Failure to install the pad grabber tightly may allow the pad to be thrown from the driver.

- There is a wide range of pads available for the many burnishing applications of this machine. Consult your local NSS authorized distributor for application recommendations

Transporting the Machine to the work site

From the pad changing position raise the back of the machine up by lifting up on the operator's handle with both hands, until you hear the adjustment knob "click" into position. The machine will automatically stop in position 2; see figure on page 4. The machine is now ready for transport.

- Push the machine to the work site turn the master switch to "I", and pull up on the dead man lever.

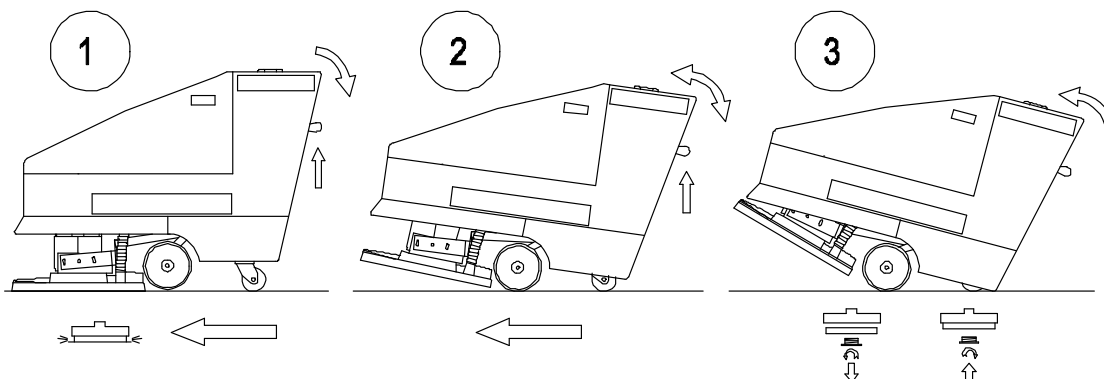

Operating the Machine

Do not operate the machine with the battery needle in the red zone.

From the transport position raise the back of the machine up by lifting up on the operator's handle with both hands. The machine will automatically stop in position 1; see figure on page 4.

- Turn the master switch to "I"; check the level of battery work range (put machine on "charge" if not in the high range).
- Push the machine forward slightly and squeeze the deadman switch lever to activate the pad driving motor.
- The machine will tilt forward slightly as the pad sucks to the floor.

CAUTION: This Machine must be moving at all times when the pad is rotating or the floor may be damaged. Never operate this machine with the needle in the red area of the amp meter, or damage to the machine from overload may result. See Setting / Adjusting Pad pressure.

Setting / Adjusting Pad Pressure

- Adjust the black knob in the center of the Control Panel counter clockwise to increase the pad pressure. It will move the AMP indicator needle more toward the right or the red area.
- Adjust the knob clockwise to decrease the pad pressure, decreasing the amps, which moves the needle to the left.
- Adjust until the AMP meter needle averages in the area of the green arrow, indicating proper amps.
- With the machine moving forward, watch the AMP meter for the average needle position on the meter.

Pad pressure relates to buffing performance.

- Too much pad pressure, (operating the machine continuously in the red area), may damage the floor, give uneven results, and / or cause the circuit breaker to blow. Push the button to reset, then, adjust the pad pressure.
- Operating the machine with higher than recommended pad pressure in the red area will also shorten the operating time per battery charge.
- Maximum operating time can be achieved by adjusting pad pressure throughout the buffing cycle.
- Too light pad pressure will also give poor results and no contact with the floor.
- The thickness of a new pad varies during the manufacturing process; however, ALL pads will thin down during use and require periodic adjustment of pad.
- Floors that have high or low spots will cause the amp meter to enter into the red area occasionally. This is to be expected and will cause no harm to the machine.

Maintenance

Daily Maintenance

- Recharge the batteries when indicated by the Battery Meter.
*325 AH batteries require 14½ -16 hours to fully charge.
- Check water level after charging batteries.
- Inspect the machine components for wear, loose fasteners, or damage.
- Call authorized service center for repairs.
- Wipe machine down with a damp cloth.
- **NEVER** spray this machine with water or any liquids.

Weekly Maintenance (Every 20 Hours)

- Verify all daily maintenance has been performed.
- Check vac hose for connection to Flexiwall Shield and filter bag. Empty the filter bag when it is more than one-half (1/2) full.
- Inspect Flexiwall Shield for dents, cracks and wear. A damaged Flexiwall Shield will greatly reduce the burnishing and dust control capabilities.
- Dirt build up on the brush should be removed.
- Never Spray machine with water or any liquids.
- Check the Battery Compartment for liquid level on a weekly basis.
- Dispose of liquids according to your local EPA regulations.

****CAUTION****

Inspect and replenish battery water in every cell in every battery weekly. Failure to maintain proper electrolyte level in every cell of every battery will cause premature battery failure, and void the warrantee.

Monthly Maintenance (Every 100 Hours)

- Verify all weekly maintenance has been performed.
- Lubricate the wheels and caster with an industrial grade bearing grease. Failure to lubricate wheels and caster will cause the machine to maneuver with difficulty and premature failure of the wheels, caster, and bearings.
- Tighten and Lube the drive motor chain.

Every 60 days (every 300 Hours)

- Verify all monthly maintenance has been performed.
- The motors require very little service. Using compressed air, blow the entire motor. Pay close attention to the carbon brush area. Accumulated dirt will cause excessive carbon brush arcing, reduced brush life, poor machine performance, and possible damage.
- Inspect ALL pad pressure / pivot linkage connections in the pad pressure adjustment and pivot linkage assembly. All linkage must move freely and smoothly to ensure proper machine operation. Lubricate each part as required with small amount of grease such as Lubriplate®.
- Failure to lubricate these components may make it impossible to adjust the pad pressure or place machine into all three positions.

Every 6 Months (every 650 – 700 Hours)

- Call your Authorized NSS distributor / Service Station to have the Drive Motor and Brush Motor carbon brushes inspected for wear.

Repairs performed by an unauthorized company will void the machine warranty. If you require assistance finding an authorized service center, contact NSS Enterprises.

Battery charger

Operating instructions

1. Connect charger power cord to a properly grounded outlet. When using an extension cord, avoid excessive voltage drop and extended charge times by using a grounded 3-wire 12 AWG cord for 50' lengths or shorter and 10AWG for greater than 50' lengths.
2. If a minimum battery voltage is not detected, a trickle current will be applied until a minimum voltage is reached.
3. Once a minimum battery voltage is detected, the charger will enter the bulk charging constant-current stage. The current bar graph will indicate the current to the battery as the charger moves through its charge profile. The length of charge time will vary by how large and how depleted the battery pack is.
4. When the yellow 80% LED is lit, the charger has completed the bulk stage of the charge and the battery is at approximately 80% of charge. The charging could be terminated at this point if the machine requires immediate usage, however, it is highly recommended to wait until the green 100% charge LED illuminates to ensure maximum battery capacity and battery life.
5. When the green 100% LED is continuously on, the batteries are completely charged. The charger may now be unplugged from AC power (always pull on plug and not cord to reduce risk of damage to the cord). If left plugged in, the charger will automatically restart a complete charge cycle if the battery pack voltage drops on average below 2.1 volts-per-cell or 30 days has elapsed.
6. If a fault occurred anytime during charging, the red FAULT LED will flash with a code corresponding to the error. To indicate which error, the FAULT LED will flash a number of times at a rate of two times per second, pause 0.5 seconds, then repeat.
 - [1 FLASH] Battery Voltage High: auto-recover
 - [2 FLASH] Battery Voltage Low: auto-recover
 - [3 FLASH] Charge Timeout: the charge did not complete in the allowed time. This may indicate a problem with the battery pack (voltage not attaining the required level), or that the charger output was reduced due to high ambient temperatures.

- Failure to replace carbon brushes will cause poor machine performance and possible motor damage.

[4 FLASH] Check Battery: the battery pack could not be trickle charged up to the minimum level required for the charge to be started. This may indicate that one or more cells in the battery pack are shorted or damaged.

[5 FLASH] Over-Temperature: auto-recover. Charger has shutdown due to high internal temperature. Charger will restart and charge to completion if temperature comes within accepted limits, but the fault LED indication will remain until the charger has been reset (AC removed).

[6 FLASH] QuiQ Fault: an internal fault has been detected. If Fault 6 is again displayed after interrupting AC power for at least 10 seconds, the charger must be brought to a qualified service depot.

Maintenance Instructions

1. For flooded lead-acid batteries, regularly check water levels of each battery cell after charging and add water as required to level specified by battery manufacturer. Follow the safety instructions recommended by the battery manufacturer.
2. Make sure charger connections to battery terminals are tight and clean.
3. Do not expose charger to oil or to direct heavy water spraying when cleaning machine.

DC Battery Connection Procedure:

1. The green wire outputs a battery voltage when the charger is not plugged in to AC to provide an Interlock function.
2. Securely fasten the black ring terminal from the charger to the negative terminal ("-", "NEG", "NEGATIVE") of the battery pack.
3. Select Charge Algorithm if battery type is other than factory default.

Check / Change Charging Algorithm:

The charger comes pre-loaded with nine algorithms for Lead Acid batteries as detailed in Table 1. Each time AC power is applied with the battery pack NOT connected, the charger enters an algorithm select/display mode for approximately 11 seconds - this is the only time the algorithm can be changed. In this mode, the present algorithm is displayed on the LED bar graph or 80% LED as shown in Table 1. If the algorithm # is from one to six, it will be displayed on the bar graph with the lowest LED indicating that Algorithm 1 is selected; the second lowest LED indicates that Algorithm 2 is selected, etc. For all algorithm #'s, the algorithm number is also indicated on the 80% LED by the number of blinks separated by a pause. *** Note- algorithms 7-9 are indicated only with the 80% LED indication - no bar graph indication is given.*

Check or change the charging algorithm:

- a. Disconnect the positive connector from battery pack. Apply AC power and after an up/down flash of the LEDs, the algorithm # will display for 11 seconds.
- b. To change algorithm, touch connector during the 11-second display period to the battery pack's positive terminal for 3 seconds and then remove- the algorithm # will advance after 3 seconds. Repeat until desired algorithm # is displayed. A 30 second timeout is extended for every increment. Incrementing beyond algorithm 9 moves back to algorithm 1. After desired algorithm is displayed, touch the charger connector to the battery positive until the output relay is heard to click (~10 seconds)- algorithm is now in permanent memory.
- c. Remove AC power from the charger and reconnect the charger positive connector to the battery pack. It is highly recommended to check a newly changed algorithm by repeating the above steps a) and c)

Delta-Q Battery Charger - Battery Types					
NSS Part Number	Crown Part Number	Battery Volts	System Volts	Amp Hour	Recommended Algorithm
4491061	1-1470	12	36	210	# 1
3390361	1-1435	6	24 & 36	225	# 1
2392111	1-1427	12	24	115	# 5
6393651	1-1428	12	24	145	# 5
2392731**	1-12145	12	24	100	# 6
6491931**	1-1437	6	24 & 36	180	# 6
2691501	1-1450	6	36	325	# 27
7691401	1-1460	6	36	395	# 27

Table 1.

**** Note: Gell Battery**

***For batteries from manufacturers other than Crown, contact NSS Customer Service for a recommended algorithm. Not all other manufacturer's batteries are compatible with the chargers supplied on NSS equipment.

TROUBLE SHOOTING

PROBLEM	CAUSE	SOLUTION
Pad Does Not Turn.	Low battery charge. Loose battery cable. Circuit breaker has tripped. Worn motor carbon brushes. Pad load adjustment knob out of adjustment. Micro switch not engaged.	Recharge batteries. Tighten and clamp battery cables. Reduce pad pressure / change pad reset breaker. Change carbon brushes. Adjust knob until motor will turn on. Adjust mounting bracket.
Machine Pushes Hard.	Worn wheel or caster. Motor out of alignment.	Grease wheels or replace. Call NSS Service Center for repair.
Uneven Floor Buffing.	Worn pad. Motor out of alignment.	Change pad. Call NSS Service Center for repair.
Machine Vibrates	Pad is torn or not centered.	Center pad. Change pad. Check pad driver for damage and replace if necessary.
Circuit Breaker Trips.	Pad pressure too heavy. Spray buffing. Pad rubbing on flexiwall shield.	Reduce pad pressure. Run machine in green area of amp meter. Do not spray buff. Realign pad on driver or replace with new pad. Check pad size.
Short Running Time on Battery Charge.	Dead cell in battery. Excessive pad pressure. Incorrect pad.	Test batteries and replace. Reduce pad pressure. Use NSS pads or recommended equivalent.
Battery Charger Does Not Turn On	Connection not made between power cord and battery charger or battery charger and machine. Improper charger sequence. Overly discharged batteries.	Check connectors for proper contact on both charger cord and machine batteries. Read instructions on battery charger or in instruction manual. Contact NSS Service Center for repair.



NSS® Enterprises, Inc.

3115 Frenchmens Road, Toledo, Ohio 43607
 PHONE (419) 531-2121 FAX (419) 531-3761
NSS® Enterprises, Inc. European Distribution Centre
 Unit II, Pinfold Trading Estate * 55 Nottingham Road
 STAPLEFORD, NOTTINGHAM NG9 8AD ENGLAND U.K.
 PHONE: (44) 0115 939 1568 * FAX: (44) 0115 949 0615