

Minuteman[®]

Instruction Manual

E 2830/3030/3330 (7311.44)

Introduction

Preface

Dear customer, It is our desire that the good characteristics of the E 28/30/33 should justify the confidence you demonstrated by making this purchase.

Prior to the first use, carefully read the chapter "Safety Information" as this will ensure your safe operation of the machine.

Your own safety, as well as the safety of others, depends to a great extent on how the machine is moved and operated. Therefore, this operation and maintenance manual must be read and understood prior to the machine being used for the first time.

The manual provides valuable information about operation, service and maintenance. The warning symbols as used in this manual identifies items relevant to safety. Please observe the safety provisions (see chapter "Safety Information").

Your authorized Minuteman dealer will be pleased to answer further questions regarding the vehicle or the operation and maintenance manual.

Please be advised explicitly that we cannot accept any legal issues out of the contents of this manual.

If repair work has to be performed make sure that only genuine spare parts are used; only genuine spare parts may guarantee a dependable machine. We reserve the right for technical improvement.

Valid as of: September 2012

Minuteman International Inc.
111 South Rohlwing Road
ADDISON, IL. 60101-4244
U.S.A.

Proper use

The scrubber is for attachment to the E 28/30/33. The E 28/30/33 is a vacuum scrubbing machine for wet cleaning of hard-surfaced floors. Using the equipment beyond this scope of application will be deemed improper use; The manufacturer cannot be held liable for consequential damages; the user alone bears the risk.

The term of proper use also includes operation, maintenance and repair work to be performed in compliance with the manufacturer's specifications.

The scrubber may only be used by persons that are familiar with the machine and aware of possible hazards involved. The applicable Accident Prevention Regulations and further regulations in vigor concerning aspects of safety and working medicine will have to be complied with. If modifications to the scrubber are made in absence of the manufacturer's prior consent, the latter cannot be held liable for damage resulting from such unauthorized modification.

Introduction

Notes on warranty

The terms of the sales contract apply. Damages are not subject to warranty if they are due to non-compliance with the maintenance and service provisions. The maintenance work has to be performed by an authorized Minuteman service center and confirmed in the "Maintenance certificate" which is the warranty document.

The following is excluded from warranty: fuses, natural wear, damages caused by overload, inexpert handling and unauthorized modification of the machine. Moreover, any claim for warranty cannot be accepted if damages of the machine are caused by fitting parts or accessories without Minuteman's prior and explicit consent or by non-compliance with the maintenance instructions.

Acceptance of the machine

Upon arrival, check machine for possible damages in transit. Follow unpacking instructions on shipping pallet. Each unit has been tested and thoroughly inspected before shipment. Any damage is the responsibility of the delivery carrier who should be notified immediately.

**Minuteman International Inc.
111 South Rohlwing Road
ADDISON, IL. 60101-4244
U.S.A.**

Table of Content



Introduction	2	3.1.2 Solution Tank	12	5.5 Solution Tank	30
Preface	2	3.1.3 Squeegee	13	5.5.1 Fill Solution Tank	31
Acceptance of the machine	3	3.1.4 Recovery Tank	13	5.5.2 Empty Solution Tank	31
1 Safety information	5	3.1.5 Travel Drive	13	5.5.3 Clean Solution Filter	31
1.1 Safety and Warning Symbols	5	3.1.6 Batteries and Charger	13	5.6 Recovery Tank	32
1.2 General Provisions	6	3.1.7 Options	13	5.6.1 Empty Recovery Tank	33
1.3 Provisions for Operation	6	3.2 Operating and Indicating Elements	14	5.6.2 Clean Recovery Tank	33
1.4 Maintenance instructions	7	3.2.1 Operating Panel	14	5.6.3 Clean Suction Filter	33
1.5 Specific Hazards	8	3.2.2 At the machine	17	5.7 Disc brush deck	34
1.6 Information for Protection of Environment	8	4 Technical Data	20	5.7.1 Clean Brushes	34
1.7 Labels at the Machine	9	5 Maintenance and Care	22	5.7.2 Change Brushes	34
2 First Operation	10	5.1 Minuteman System Maintenance	22	5.7.3 Change Deflector Roller	34
2.1 Instruction	10	5.2 Maintenance Document	23	5.7.4 Change Sealing Strip	34
2.2 Initial charging procedure	10	5.3 Maintenance Schedule	24	5.8 Cylindrical brush deck	35
2.3 Before Putting into Operation	10	5.4 Battery Systems	28	5.8.1 Clean dirt hopper	35
2.4 Start Machine	10	5.4.1 Charge Batteries	29	5.8.2 Remove brushes	35
2.5 Operation	10	5.4.2 Low Discharge Signal sender (LDS)	29	5.8.3 Clean brushes	35
2.6 Stop Machine	11	5.4.3 Maintenance of Drive Batteries	29	5.8.4 Fit brushes	35
2.7 After Work	11	5.4.4 Remove Batteries	29	5.8.5 Change deflector roller	35
2.9 Tie-down points	11	5.4.5 Install Batteries	29	5.9 Squeegee	36
3 Operation	12	5.4.6 Disposal of Batteries	29	5.9.1 Cleaning the Squeegee	36
3.1 Method of operation	12			5.9.2 Changing the Sealing Strips	36
3.1.1 Brush Deck	12			5.9.3 Adjusting the Sealing Strips	37

Safety information

1 Safety information

1.1 Safety and Warning Symbols

All paragraphs in this manual referring to your personal safety, the safety of your machine and the environment protection are attributed one of the following warning symbols:

Symbol	Hazardous for ...	Description
Safety Provisions 	persons and goods	Safety Provisions in dangerous situation caused by misuse inaccurate adherence of instructions or prescribed work routine.
CAUTION 	the machine	important information on handling the machine in order to maintain operability.
Ecological hazard 	the environment	due to use of substances representing an inherent danger to health of environment

Safety information

1.2 General Provisions

- Apart from the provisions contained in this instruction manual, the general safety provisions and the accident prevention regulations as imposed by law have to be complied with.
- Before taking your machine into operation, carefully read the instruction manual as well as other separate instructions for accessories or attached implements and comply with all points mentioned there during work.
- Persons being trained by qualified Minuteman technicians only are authorized to operate, service and repair the machine.
- You are advised to thoroughly study the safety instructions since precise knowledge helps prevent errors during machine operation and thus guarantee proper use of the machine.
- The operating instructions have to be at hand at the place of use of the machine, and therefore have to be kept readily available at the machine.
- When selling or letting the machine for rent, hand out these documents

to the new owner/operator and have the transfer certified!

- The warning and instruction plates attached to the machine contain valuable advice about safe operation. Immediately replace incomplete or illegible labels.
- As far as safety standards are concerned, spare have to equal genuine spare parts!

1.3 Provisions for Operation

- Before first operation of the machine, fully charge the battery with an initial charging procedure and comply with the operating instructions of the charger as well as with those of the battery manufacturer. Minuteman cannot be held liable for damages resulting from an insufficient initial charge.
- Before taking into operation, check the machine for operational safety! Immediately remedy malfunctions!
- It is indispensable for the operator to get acquainted with all attached implements and controls as well as with their function before operation begins. Once you have started to work, no time will be left to do so!
- When working with the machine use firm and skid proof shoes.
- The machine may be used only on such surfaces clearly specified by the owner or his authorised representative.
- When working with the machine, pay strict attention to any persons in the close vicinity.
- Start moving immediately after brush deck has switch on otherwise the

Safety information

brush might leave traces on the floor. Lift the brush deck before moving over obstacles (doorsteps).

- Use only cleaning agents suitable for automatic machines (low-foaming) and comply with the instructions for use, disposal and with the warning information specified by the cleaning agent's manufacturer.
- Only fold open empty recovery tank.
- The machine is not designed for collecting hazardous, inflammable or explosive dusts or substances.
- Usage of the machine in explosive areas is prohibited.
- Pull the switching key to avoid unauthorized use of the machine.
- Before transport of the machine, lift the squeegee and the brush deck. Adapt driving habits to local conditions.
- The machine may be used only for operation on plane areas with a maximum inclination of up to 10%.

1.4 Maintenance instructions

- The daily and weekly maintenance and repair task must be performed by a qualified operator. For further maintenance and repair work beyond please contact your local Minuteman service center.
- Observe the maintenance activities and intervals set out in the instruction manual.
- Maintenance and repair work may be carried out only by means of appropriate tools.
- Have the machine checked for safe condition in the sense of the Accident Prevention Regulation by an expert at regular intervals (recommendation: at least once yearly) as well as after modifications or repair.
- Spare parts have to equal the technical requirements as specified by the manufacturer! Genuine spare parts guarantee compliance with these requirements.
- Switch off the engine and remove the key before inspecting the machine or performing any maintenance work.
- To prevent the machine from being used by unauthorized persons, the

control key must be removed.

- When performing work at the electrical system, be sure to disconnect the battery plug.
- Make sure to protect the recovery tank against accidental closing or tilting down before working in the area of a lifted tank lid.
- Do not clean the electrical parts by means of high-pressure cleaning equipment.
- The use of aggressive detergents is prohibited.
- Let the machine dry after cleaning.
- The machine may be taken into operation after all protective devices have been fitted and positioned.

Safety information

1.5 Specific Hazards

Electric system

- Only use genuine fuses with the specified ratings.
- In case of malfunction of the electric system, shut the machine down immediately and have it serviced.
- Only qualified personnel are authorized to work on the electrical installations and only according to electro-technical rules.
- Inspect/check the electrical equipment of the machine at regular intervals. Clear up any defects immediately, such as loose connections or damaged cables.

Battery

- Observe the operating instructions of the battery manufacturer.
- Never place metal objects or tools on batteries - short-circuit hazard!
- Due to alteration of the centre of gravity, only use batteries as released and at the prescribed position only.
- Provide for sufficient ventilation of areas where batteries are charged. – Explosion hazard!

1.6 Information for Protection of Environment

- For safe use of substances inheriting a danger to health and environment specific knowledge is required.
- Observe the legal directives and local regulations for disposal of detergents.
- Used batteries labelled as recyclable contain reusable economic goods. According to the crossed garbage can label these batteries must not be added to the normal waste.

Safety information

1.7 Labels at the Machine

The following safety and information labels are legibly attached to the machine. Replace missing or illegible labels immediately.

Minuteman nameplate (Fig. 1/1)

Minuteman®

Machine identification number (Fig. 1/2)



Recovery tank drain hose (Fig. 1/3)

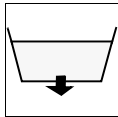

A = Read and observe the instruction manual (Fig. 1/2)
B = Maximum inclination of 10% (Fig. 1/2)
C = Do not clean the machine by means of high-pressure cleaning equipment (Fig. 1/2)

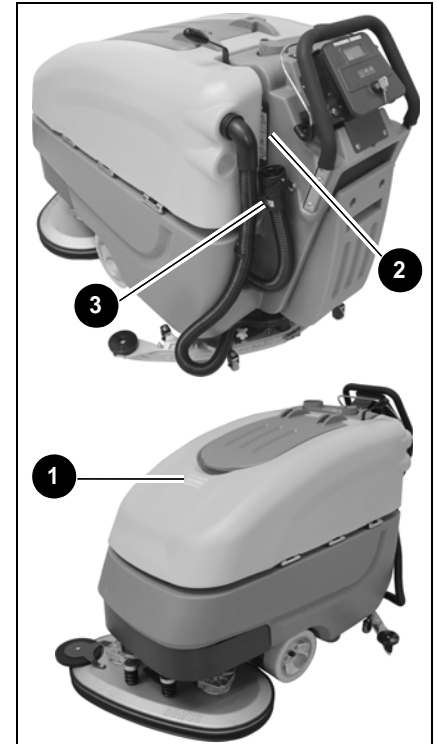
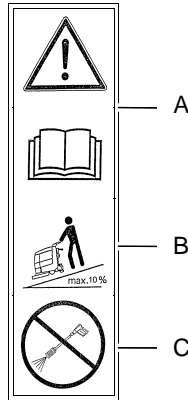

Fig.1

First Operation

2 First Operation

2.1 Instruction

Only persons trained by qualified Minuteman technicians are authorized to operate, service and repair the machine. Operators must read and understand this manual before operating or maintaining this machine.

2.2 Initial charging procedure



Before first operation of the machine, fully charge the battery with an initial charging procedure and comply with the operating instructions of the charger as well as with those of the battery manufacturer. Minuteman cannot be held liable for damages resulting from an insufficient initial charge.

2.3 Before Putting into Operation

Complete the following inspections before taking the machine into operation:

1. Check the area around the machine for signs of leakage. Hoses, lines and tanks must be free from any leakage or damage.
2. Install brushes and squeegee, see

maintenance chapter.

3. Install batteries and connect battery plug, see maintenance chapter.
4. Check battery charge and proceed to re-charging of batteries if required. Generally proceed to initial charging before first operation of the machine.
5. Empty recovery tank and clean it if required, see maintenance chapter.
6. Re-fill solution tank and add cleaning agent according to the manufacturer's recommendations.



Use only cleaning agents suitable for automatic machines (low-foaming) and comply with the instructions for use, disposal and with the warning information specified by the cleaning agent's manufacturer.

2.4 Start Machine

Proceed with the following to set the machine to operating mode:

- Disconnect mains plug of the charger from outlet and fasten to holder.
- Switch on machine by actuation of key switch from position (0) to position (1).

2.5 Operation

1. Switch on the machine.
2. Use lever (Fig. 5/3) to lower squeegee. Suction turbine switches on automatically.
3. Switch on solution supply by means of tip-switch (Fig. 4/14).
4. Adjust solution amount by means of tip-switch (Fig. 4/13). Lower brush deck via pedal (Fig. 3/8). Solution supply and brush deck starts automatically.
5. Use the speed control knob (Fig. 4/16b) to adjust the work speed. Use the direction switch (Fig. 4/16a) to select forward or reverse. Pull the bail handle (Fig. 4/16c) to start moving.



Start moving machine immediately after switch on the brush deck, otherwise the brushes leave traces on the floor. Lift brush deck before passing over steps and other obstacles.

First Operation

2.6 Stop Machine

Releasing the bail handle will stop the motion of the machine as well as the brush deck and the solution supply. Switch the machine off using the key-operated switch. Protect the machine against unintentional movements or against being inadvertently started.

2.7 After Work

1. Move the machine to a suitable site for maintenance.
2. Stop machine, lift squeegee and brush deck and remove the key.
3. Empty and clean recovery tank.



Observe the legal directives and local regulations for disposal of detergents.

4. Check solution filter.
 5. Check seals and suction hose.
 6. Check operating fluid levels, function and setting.
 7. Charge batteries.
 8. Clean the machine.
- Empty the solution tank before shutting down the machine for a longer time.



Do not clean the electrical parts by using high pressure cleaning equipment.

2.8 Transporting the machine

To move the machine to the place where it is to be used, switch it on, lift-out squeegee and brush deck pull the bail handle start movement.

2.9 Tie-down points

In case of transport on a vehicle or trailer, the machine has to be protected against rolling off. Tie the machine down firmly by lashing it to the front with the eye bolts (Fig. 2/1) and to the rear with the chassis (Fig. 2/2).

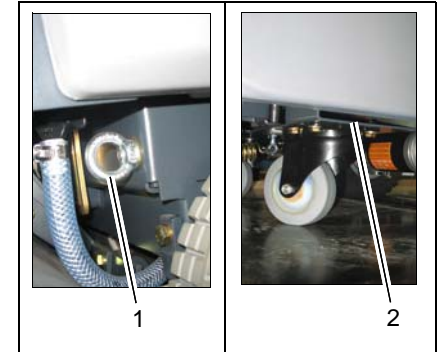

Fig.2

3 Operation

3.1 Method of operation

General

The E 28/30/33 is a vacuum scrubbing machine for wet cleaning of hard-surfaced floors.

3.1.1 Brush Deck

Lower brush deck (Fig. 3/1) via pedal before scrubbing. The brushes rotate and solution supply starts automatically when bail handle is pulled. When machine stopped, brushes and solution supply switch off automatically. The figures represent disc brush deck type machines. Equipment of the machine with cylindrical brush deck is also available.

3.1.2 Solution Tank

Fill the solution tank (Fig. 3/2) after folding up the opening. The solution tank holds 113 liters and the filling level can be checked visually (through transparent hose).



Fig.3

Operation

3.1.3 Squeegee

The movable squeegee (Fig. 3/3) consists of the squeegee lift-out, the suction turbine and sealing strips. The soiled water is wiped from the floor by means of sealing strips. Squeegee is lowered via hand lever (Fig. 3/8) . Simultaneously, the suction turbine switches on. The suction turbine works independent of direction of travel and even if the machine stops. Second actuation of the hand lever lifts the squeegee up again and suction turbine is automatically switched off with a delay of 15 seconds.

3.1.4 Recovery Tank

The soiled water is taken from squeegee to the recovery tank (Fig. 3/4) by suction turbine and suction hose.

3.1.5 Travel Drive

The machine features a continuous travel drive (Fig. 3/6). The electronic travel drive control realises modification of travel speed, direction as well as dynamic braking.

3.1.6 Batteries and Charger

The machine is equipped with an automatic charger unit (Fig. 3/7) and a low discharge signal sender (LDS) for protection against low discharge.

3.1.7 Options

- Extraction hose including suction pipe, joint nozzle and wet suction nozzle
- Mop holder and tool-box for cleaning utensils



Accessories such as brushes, rollers, pads, pad holder with centerlock and sealing strips are available. Contact your Minuteman Dealer for more information.

Operation

3.2 Operating and Indicating Elements

3.2.1 Operating Panel

- 1 Display
- 2 Key switch
- 3 Battery charge indication
- 4 LDS indicator
- 5 Symbol brush drive
- 6 Symbol suction turbine drive
- 7 Hourmeter
- 8 Symbol Service indicator
- 9 free
- 10 Symbol Silence Kit (optional)
- 11 Symbol solution dosage
- 12 Tip-switch Silence Kit (optional)
- 13 Tip-switch solution dosage
- 14 Tip-switch solution supply On/Off
- 15 free
- 16 Drive direction control (16a) with speed control knob (16b) and bail handle (16c)

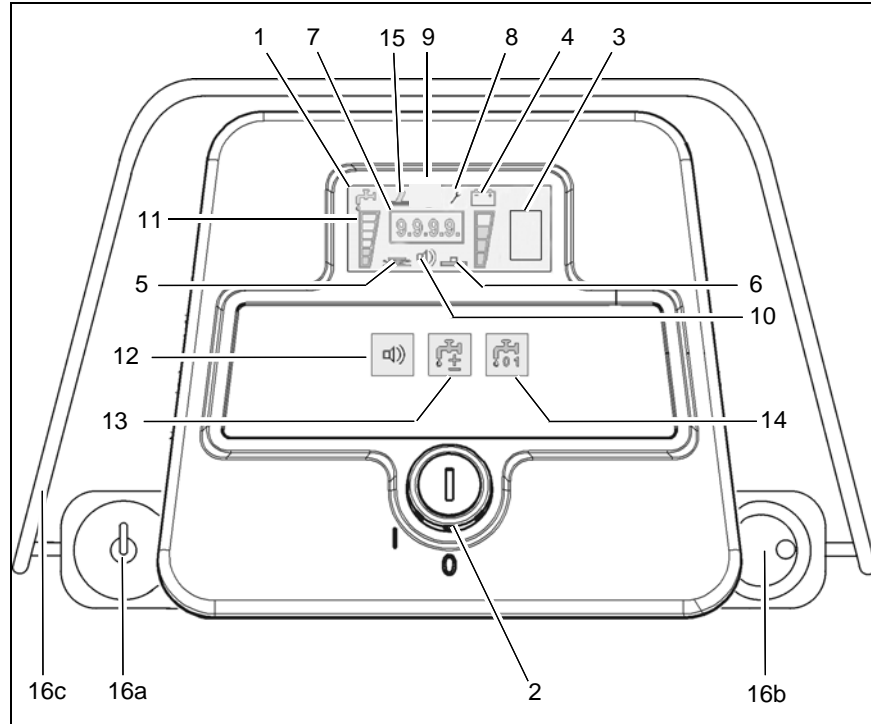

Fig.4

Operation

Display (Fig. 4/1)

This panel allows centralized monitoring of functions and detection of all available operating modes.



The key switch turns the electrical system on and off.



Remove the key to avoid unauthorized use of the machine.

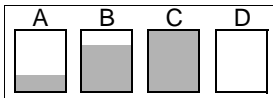

Battery charge indication (Fig. 4/3)

Battery charge indication appears on the panel during the charging procedure and shows the current charge condition of batteries during the procedure. The following symbols appear:

Battery symbol A < charge of 20 %

Battery symbol B = charge of 80 %

Battery symbol C = charge of 100 %

Battery symbol D (flashes) = error



LDS indicator (Fig. 4/4)

Upon switching on, the LDS indication is output on the panel to show the current battery charge condition during operation. Additional Information see chapter maintenance.



Symbol brush drive (Fig. 4/5)

This symbol appears when brush drive is switched on.



Symbol suction turbine drive (Fig. 4/6)

This symbol appears when suction turbine drive is switched on.

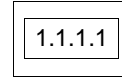

Hourmeter (Fig. 4/7)

Upon switching on, the hourmeter briefly displays the software version and the last error code. Then the current operating hour level is shown.



Service indicator (Fig. 4/8)

The service indicator lights after occurrence of a system error and cleaning or transporting procedure is interrupted. In addition to the service indicator, a 4-digit code is displayed on the hourmeter.

Operation



free (Fig. 4/9)



Silence Kit tip symbol (optional)
(Fig. 4/10)

This symbol appears when Silence Kit tip-switch is switched on.



Solution dosage symbol (Fig. 4/11)

This symbol appears upon actuation of the solution dosage tip-switch.



Silence Kit tip-switch (optional) (Fig. 4/12)

This tip-switch is used to change suction turbine to silent mode. The silent mode symbol appears in the display.



Solution dosage tip-switch (Fig. 4/13)

This tip-switch is used to regulate the amount of solution. Additionally, solution amount is adapted to driving speed. The display shows a six-stage symbol for the supplied amount of solution.



Solution supply ON/OFF tip-switch
(Fig. 4/14)

This tip-switch is used to switch solution supply ON or OFF.



free (Fig. 4/15)

Drive direction control with speed control knob/bail handle (Fig. 4/16)

The drive direction control (16a) is used to control the driving direction (forward or reverse). The bail handle (16c) must be pressed in order to drive. The speed can be adjusted continuously by means of the speed control knob (16b). The machine stops when the bail handle is released (deadman function).



Protect the machine against rolling off before leaving it unattended.

Operation

3.2.2 At the machine

- 1 Pedal brush deck
- 2 Opening of solution tank
- 3 Hand lever for squeegee lift-out
- 4 Solution filter
- 5 Recovery drain hose
- 6 Solution level indication
- 7 Brush ejector
- 8 Power connection charger unit
- 9 Pedal brush deck pressure

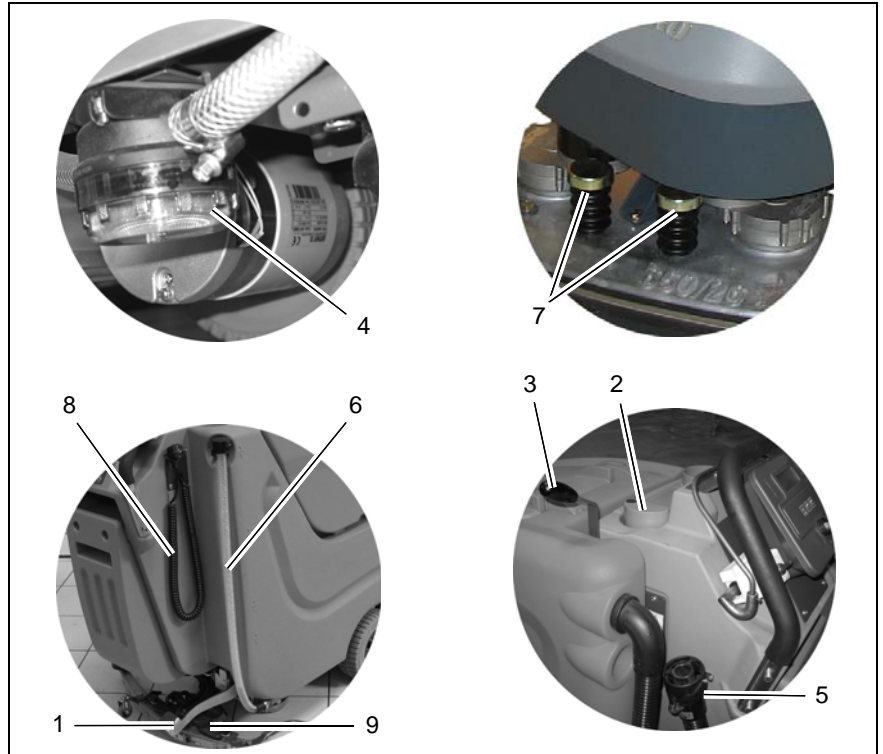

Fig.5

Operation

Pedal brush deck (Fig. 5/1)

Use this pedal to lift and lower the brush deck.

Opening of solution tank (Fig. 5/2)

The solution tank is filled after folding up the opening.

Hand lever for squeegee lift-out (Fig. 5/3)

Use this hand lever to lift and lower the squeegee.

Solution filter (Fig. 5/4)

While solution flows from tank to brush deck, it is cleaned by the filter element.

Recovery tank drain hose (Fig. 5/5)

This hose allows draining the collected soiled water from the tank.

Solution tank drain hose (Fig. 5/6)

This hose allows draining the solution tank.

Brush ejector (Fig. 5/7)

The brush ejector makes brush removal fast and easy.

Power connection charger unit (Fig. 5/8)

The power connection supplies the charger unit with power.

Pedal brush deck pressure (Fig. 5/9)

This pedal allows increasing the ground pressure of the brush deck.

Operation

Dirt hopper guiding rail (Fig. 6/1)

The dirt hopper located at the cylindrical brush deck is fastened by a guiding rail. This dirt hopper may be easily removed for cleaning.

Lever for cylindrical brush seating (Fig. 6/2)

This lever (both sides) is used to release/lock the cylindrical brush seating. The cylindrical brush may be easily removed without tools.

Swing aside squeegee

Swing aside the squeegee in lifted-out condition to allow passage through narrow clearances. This can be done by foot or by hand by swinging the squeegee to the left in the area of the deflector bail / deflector roller until the locking pin (Fig. 6/3) catches. In order to release locking of the squeegee, actuate the hand lever (Fig. 5/3) of the squeegee lift-out (lowering).

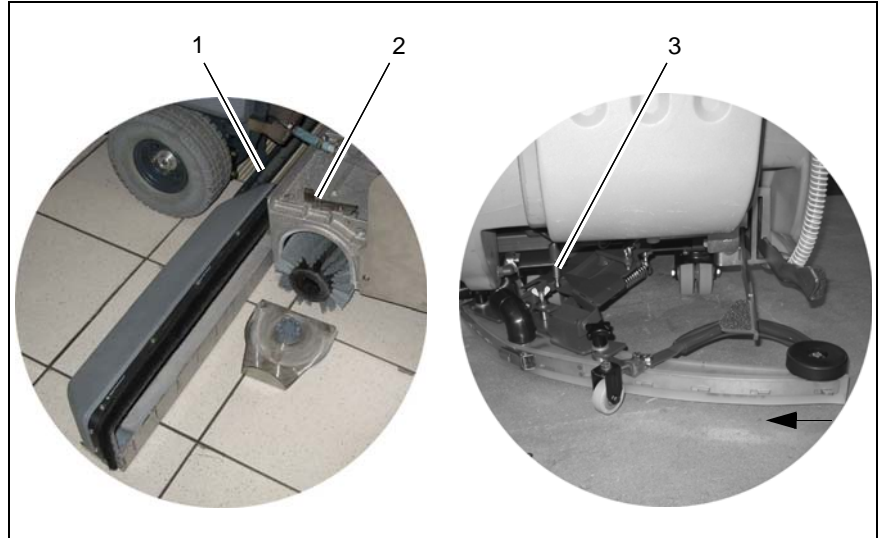

Fig.6

- 1 Dirt hopper guiding rail
- 2 Lever for cylindrical brush seating
- 3 locking pin

Technical Data

4 Technical Data

	Measure	Disc Brush 30"	Disc Brush 33"	Cylindr. Brush 28"
Machine length	in	65	68	64
Machine height	in	45	45	45
Machine width without Squeegee	in	31,5	35	31
Machine width with Squeegee	in	43	43	43
Working width	in	30	33	28
Squeegee width	in	43	43	43
Surface performance theoretical	ft ² /h	32300	36600	30150
Service voltage	V	24	24	24
Nominal power drive motor	W	480	480	480
Nominal power suction motor	W	520	520	520
Nominal power brush motor	W	2x720	2x912	2x876
Number of brushes	Qty.	2	2	2
Diameter of brushes	in	15	17	6
Work ride	mph	3,0	3,0	3,0
Solution tank	gallon	29,5	29,5	29,5
Recovery tank	gallon	28,5	28,5	28,5
Maximum inclination	%	10	10	10
Weight with solution and batteries	lbs	1150	1205	1111

Technical Data

<p>Noise emission</p> <p>The sound pressure level measured under maximum conditions of use (LwA) according to DIN EN 60335-2-72 amounts to:</p> <p>The sound pressure level measured (at the ear of the driver) under normal conditions of use (LpA) according to DIN EN 60335-2-72 amounts to:</p> <p>Measurement inaccuracy (KpA):</p>	<p>dB (A)</p> <p>dB (A)</p> <p>dB (A)</p>	<p>82</p> <p>67</p> <p>1,6</p>
<p>Vibration</p> <p>The frequency weighted acceleration measured according to DIN EN ISO 5349 which have an effect upon the upper limbs (hand-arm-system) amounts under normal working conditions:</p>	<p>m/s²</p>	<p>< 0,8</p>

5 Maintenance and Care

General



Before proceeding to maintenance and care work you are advised to read and comply with the Safety Information chapter!

Compliance with the recommended maintenance work will ensure that you always have a reliable machine available.

Daily or weekly maintenance and repair work may be executed by the driver/operator having been trained accordingly. Further Minuteman system maintenance work must be completed executed by qualified personnel only. Please contact your local Minuteman Service Center or Minuteman contract dealer. We cannot be held liable for damages resulting from non-compliance with these instructions.

Please indicate the machine's serial number with any enquiry or spare part order, see paragraph 1.7 - Nameplate.

5.1 Minuteman System Maintenance

The Minuteman System Maintenance:

- guarantees reliable operability of the Minuteman machines (preventive maintenance)
- minimizes operating costs, repair costs and maintenance costs
- ensures long service life and operability of the machine

The Minuteman System Maintenance is structured in separate modules and determines specific technical works to be executed as well as the intervals for such maintenance works. For any specific maintenance type, the replacement parts are determined and listed in spare part kits.

System Maintenance K:

To be performed by the customer in accordance to the maintenance and care instructions contained in the operating instructions (daily or weekly). The driver/operator will be instructed upon delivery of the machine.

System Maintenance I :

(every 125 hours of operation)

To be performed by qualified personnel of authorized Minuteman Service Centre in accordance with the machine-specific system maintenance including spare part kit.

System Maintenance II:

(every 250 hours of operation)

To be performed by qualified personnel of authorized Minuteman Service Centre in accordance with the machine-specific system maintenance including spare part kit.

System Maintenance S:

(every 500 hours of operation safety check)

To be performed by qualified personnel of authorized Minuteman Service Centre in accordance with the machine-specific system maintenance including spare part kit.

Maintenance and Care

5.2 Maintenance Document

<p style="text-align: center;">Handing over</p> <p>Upgrade Test drive Handing over to the customer Instruction carried out on: at _____ operating hours</p>	<p style="text-align: center;">System Maintenance I 125 operating hours Workshop stamp</p> <p>carried out on: at _____ operating hours</p>	<p style="text-align: center;">System Maintenance II 250 operating hours Workshop stamp</p> <p>carried out on: at _____ operating hours</p>	<p style="text-align: center;">System Maintenance I 375 operating hours Workshop stamp</p> <p>carried out on: at _____ operating hours</p>
<p style="text-align: center;">System Maintenance S 500 operating hours Workshop stamp</p> <p>carried out on: at _____ operating hours</p>	<p style="text-align: center;">System Maintenance I 625 operating hours Workshop stamp</p> <p>carried out on: at _____ operating hours</p>	<p style="text-align: center;">System Maintenance II 750 operating hours Workshop stamp</p> <p>carried out on: at _____ operating hours</p>	<p style="text-align: center;">System Maintenance I 875 operating hours Workshop stamp</p> <p>carried out on: at _____ operating hours</p>
<p style="text-align: center;">System Maintenance S 1000 operating hours Workshop stamp</p> <p>carried out on: at _____ operating hours</p>	<p style="text-align: center;">System Maintenance I 1125 operating hours Workshop stamp</p> <p>carried out on: at _____ operating hours</p>	<p style="text-align: center;">System Maintenance II 1250 operating hours Workshop stamp</p> <p>carried out on: at _____ operating hours</p>	<p style="text-align: center;">System Maintenance I 1375 operating hours Workshop stamp</p> <p>carried out on: at _____ operating hours</p>

Maintenance and Care

5.3 Maintenance Schedule System Maintenance Customer

The daily and weekly maintenance intervals must be performed by the customer/operator.

To be performed	Interval	
	daily	weekly
Fill solution tank and proceed to chemical agent dosage	o	
Charge batteries	o	
Check brush deck and clean if required	o	
Check squeegee and clean if required	o	
Clean tank lid seal of the recovery tank	o	
Empty recovery tank. Clean recovery tank and suction filter	o	
Check brushes/pads and replace if required		o
Clean suction hose of recovery tank		o
Check squeegee sealing strips and turn around or replace if required		o
Clean drain hose of solution tank		o
Check solution supply to brushes and clean if required		o
Check solution filter and clean if required		o
Test drive and function test		o

Maintenance and Care

System Maintenance I

The following maintenance work must be performed by an authorized Minute-man Service workshop.

To be performed	Interval
	every 125 hours of operation
Check battery charger	o
Check tank lid seal of the recovery tank and replace if required	o
Check drain hose of the recovery tank and replace if required	o
Grease joints at the brush lift-out	o
Check wheel fixing screws and tighten (24 lb ft) if required	o
Check condition of tires	o
Grease joints at the squeegee holder	o
Test drive and function test	o

Maintenance and Care

System Maintenance II

The following maintenance work must be performed by an authorized Minute-man Service workshop.

To be performed	Interval
	every 250 hours of operation
Perform maintenance works according to System Maintenance I	o
Inspect steering rollers for tread damages and bearing slackness and replace if required	o
Check drain hose of the recovery tank and replace if required	o
Check deflector roller of the brush deck and replace if required	o
Check suction hose for tight fitting and damages and replace if required	o
Check supporting wheel of the squeegee and replace if required	o
Test drive and function test	o

Maintenance and Care

System Maintenance S (Safety check)

The following maintenance work must be performed by an authorized Minute-man Service workshop at least once a year.

To be performed	Interval
	every 500 hours of operation
Perform maintenance works according to System Maintenance II	o
Clean travel drive motor from carbon dust and check carbon brushes for smooth operation and wearing and replace carbon brushes if required	o
Clean brush motors from carbon dust and check carbon brushes for smooth operation and wearing and replace carbon brushes if required	o
Test drive and function test	o

Maintenance and Care

5.4 Battery Systems

- 1 LDS display
- 2 Charger indicator
- 3 Charger
- 4 Mains cable charger
- 5 Battery connector
- 6 Batteries
- 7 Recovery tank
- 8 Support
- 9 Wiring diagram



Handling and changes of the batteries may take place only by maintenance staff.

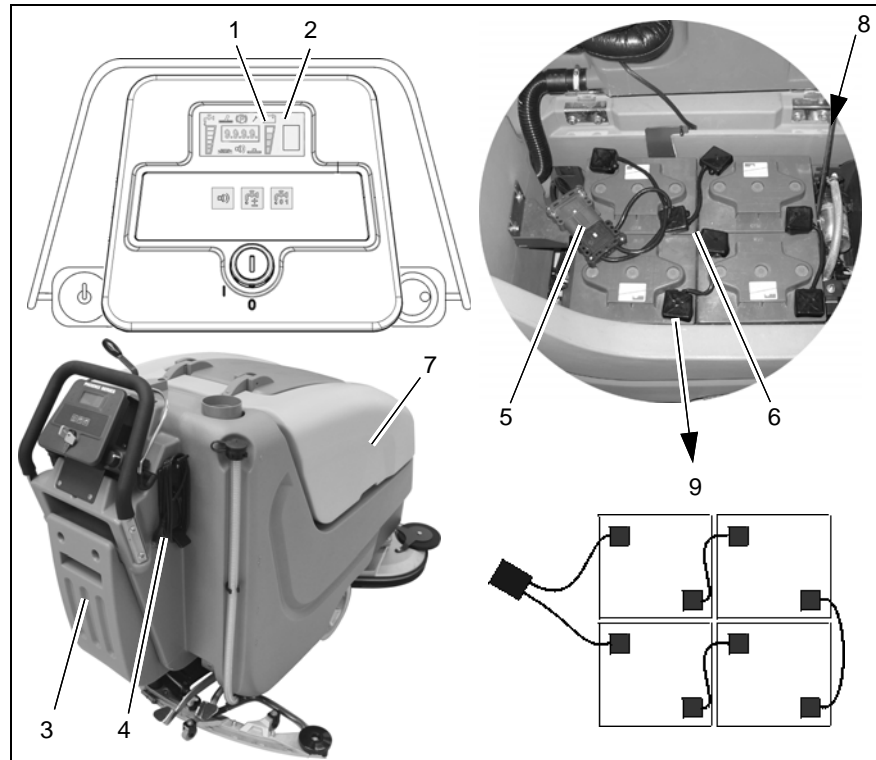

Fig.7

Maintenance and Care

5.4.1 Charge Batteries

Use the integrated battery charger (Fig. 7/3) to charge batteries. Proceed to connection of the charger by means of the mains cable (Fig. 7/4) with safety plug. Charging batteries is recommended if at least one bar of the LDS display has extinguished after operation of the machine. On this behalf you are requested to observe the operating instructions of the charger 88-60-2723 as well as the operating instructions of the battery manufacturer. In case it is intended to change the type of battery the charger has to be adjusted only by Minuteman contract workshops.



Charge the batteries properly before starting the machine for the first time. Minuteman cannot be held liable for battery damage resulting from failure to initially charge batteries.



Provide for sufficient ventilation of areas where batteries are charged. – Explosion hazard!

5.4.2 Low Discharge Signal sender (LDS)

The machine has been equipped with a charge indicator to preclude the batteries from low discharge. This low discharge signal sender has been integrated into the electronics. If other batteries are used, re-adjustment of the low discharge signal sender is required.



Only Minuteman contract workshops are authorized to adjust the low discharge signal sender.

5.4.3 Maintenance of Drive Batteries

Refer to operating instructions 88-60-2556 for information on care of drive batteries.

5.4.4 Remove Batteries

1. Park machine on level ground.
2. Switch off machine by key switch.
3. Open empty recovery tank (Fig. 7/7) and secure by support (Fig. 7/8).
4. Disconnect battery connector (Fig. 7/5).
5. Disconnect battery connection cables.
6. Remove batteries.

5.4.5 Install Batteries



Due to alteration of the centre of gravity, only use batteries as released and at the prescribed position only.

1. Switch off machine by key switch.
2. Open empty recovery tank (Fig. 7/7) and secure by support (Fig. 7/8).
3. Place batteries into trough according to figure.
4. Connect battery poles and enclosed connecting cables according to wiring diagram (Fig. 7/9). Provide for tight fitting and grease poles.

5.4.6 Disposal of Batteries

Used batteries labelled by the recycling sign contain re-usable substances. Such batteries must not be added to normal household waste. Obtain local information for the proper disposal of used batteries.

Maintenance and Care

5.5 Solution Tank

- 1 Solution tank
- 2 Marker
- 3 Fill level hose
- 4 Solution filter
- 5 Tank lid

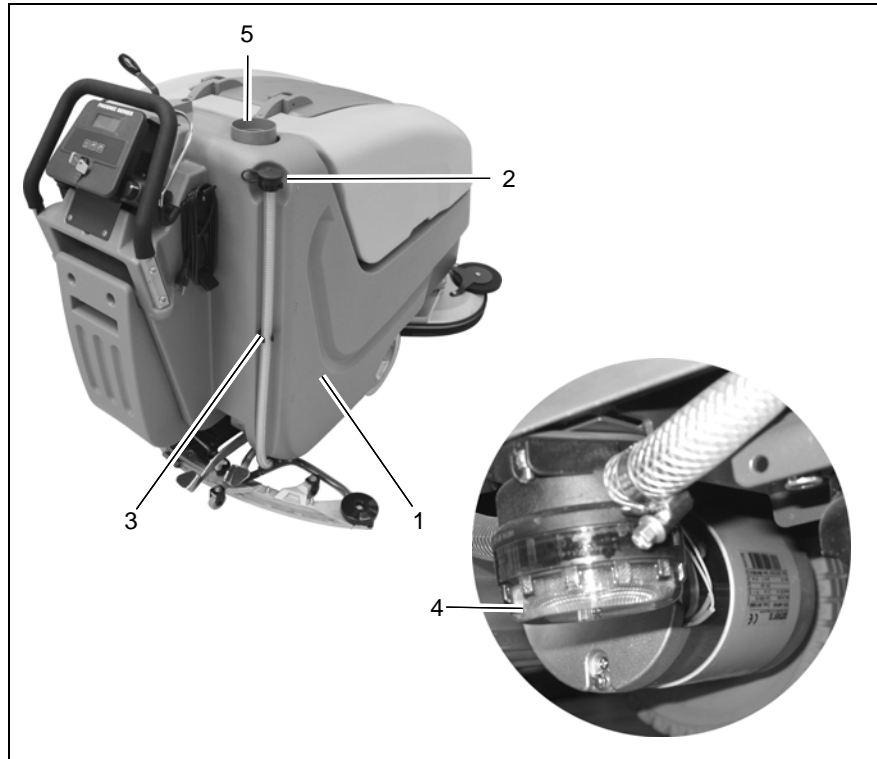

Fig.8

Maintenance and Care

5.5.1 Fill Solution Tank

Fill solution tank (Fig. 8/1) before work or as required. Park vehicle on level ground. Open tank lid (Fig. 8/5) and fill tank up to the maximum (1/1 marker) (Fig. 8/2).

5.5.2 Empty Solution Tank

Park vehicle such that the fill level hose (Fig. 8/3) is located above the drain aperture in the floor. Take fill level hose from holder and remove lid.

5.5.3 Clean Solution Filter

Check solution filter (Fig. 8/4) at weekly intervals and clean or replace if required.



Only clean solution filter with emptied solution tank.

1. Empty solution tank (Fig. 8/1), refer to Section 5.5.2.
2. Unscrew filter cap.
3. Remove the filter element from the filter case for cleaning. Replace if required.
4. Re-install filter element and filter cap.

5.6 Recovery Tank

- 1 Recovery Tank
- 2 Drain hose
- 3 Suction filter
- 4 Tank lid

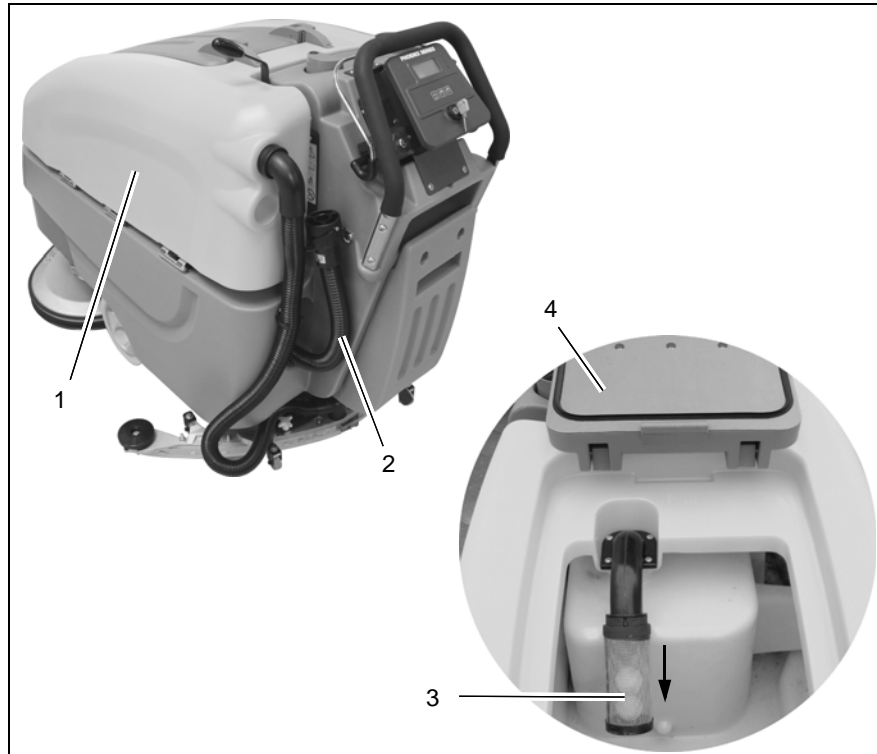

Fig.9

Maintenance and Care

5.6.1 Empty Recovery Tank

Clean recovery tank (Fig. 9/1) at daily intervals, as required or upon acoustic signal (increased suction turbine speed).

1. Take machine to appropriate place for discharge.
2. Park machine such that drain hose attains drain aperture in the floor.
3. Switch off machine.



Observe the legal provisions and the local regulations for disposal of detergents!

4. Take drain hose (Fig. 9/2) from holder and empty recovery tank completely.

5.6.2 Clean Recovery Tank

Clean recovery tank (Fig. 9/1) at daily intervals or as required.

1. Empty recovery tank, refer to Section 5.6.1.
2. Open tank lid (Fig. 9/4) of the recovery tank.
3. Take drain hose (Fig. 9/2) from holder and empty recovery tank completely.
4. Remove remaining dirt by rinsing with clear water.
5. Rinse drain hose as well.

5.6.3 Clean Suction Filter

Check suction filter (Fig. 9/3) for function at daily intervals and clean if required. The suction filter is clipped and can be easily removed.

Maintenance and Care

5.7 Disc brush deck

- 1 Toggle-type fastener
- 2 Brush deck
- 3 Brush ejectors
- 4 Deflector roller
- 5 Sealing strip

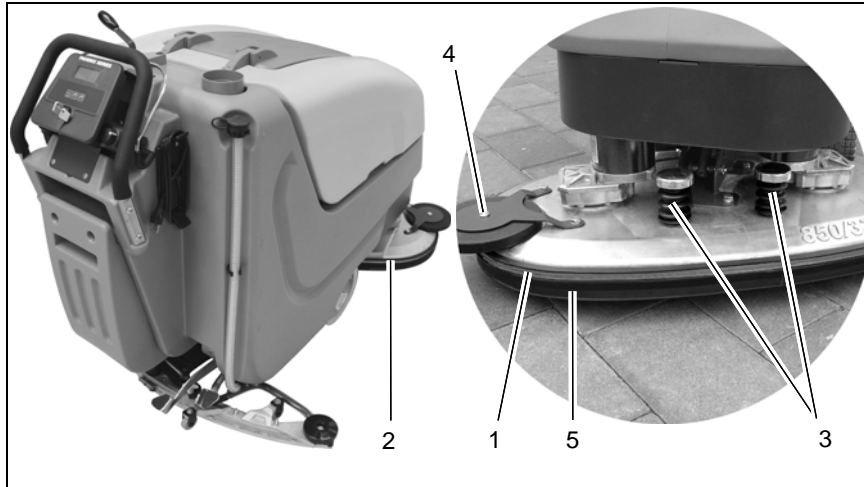

Fig.10

5.7.1 Clean Brushes

Clean brushes of the brush deck (Fig. 10/2) at daily intervals or as required. Press brush ejectors (Fig. 10/3) down to remove brushes for cleaning.

5.7.2 Change Brushes

Check brushes of the brush deck for wearing at weekly intervals. Replace brushes if bristles are worn down to a length of 1.5 cm.

1. Press brush ejectors (Fig. 10/3) down to remove old brushes.
2. Push new brush under brush deck and use both hands to press it into seating.

5.7.3 Change Deflector Roller

Check deflector roller (Fig. 10/4) at weekly intervals or replace as required.

5.7.4 Change Sealing Strip

Check sealing strip (Fig. 10/5) at weekly intervals or as required. Before doing so, open toggle-type fastener (Fig. 10/1) and remove sealing strip. Proceed to mounting in inverse order.

Maintenance and Care

5.8 Cylindrical brush deck

- 1 Brush tooting
- 2 Dirt hopper
- 3 Cylindrical brush deck
- 4 Deflector rollers
- 5 Quick-release
- 6 Feed inlet
- 7 Brush seating
- 8 Locking lever

5.8.1 Clean dirt hopper

Clean dirt hopper (Fig. 11/2) at daily intervals or as required.

Remove dirt hopper from the right machine side (seen in direction of travel). Use quick-release (Fig. 11/5) to loosen feed inlet (Fig. 11/6) and clean dirt hopper.

5.8.2 Remove brushes

1. Release brush seating (Fig. 11/7) by locking lever (Fig. 11/8).
2. Remove brush seating by lowering and removing it to the front.
3. Remove and check the brushes.

5.8.3 Clean brushes

Clean brushes in the brush deck at daily intervals or as required.

5.8.4 Fit brushes

Check brushes in the brush deck for wearing at weekly intervals and replace as required.

1. Insert brush into brush deck and let it catch (brush tooting (Fig. 11/1)) as to point to the outside).
2. Place brush seating and lock by lever.

5.8.5 Change deflector roller

Check deflector rollers (Fig. 11/4) at weekly intervals and replace if required.

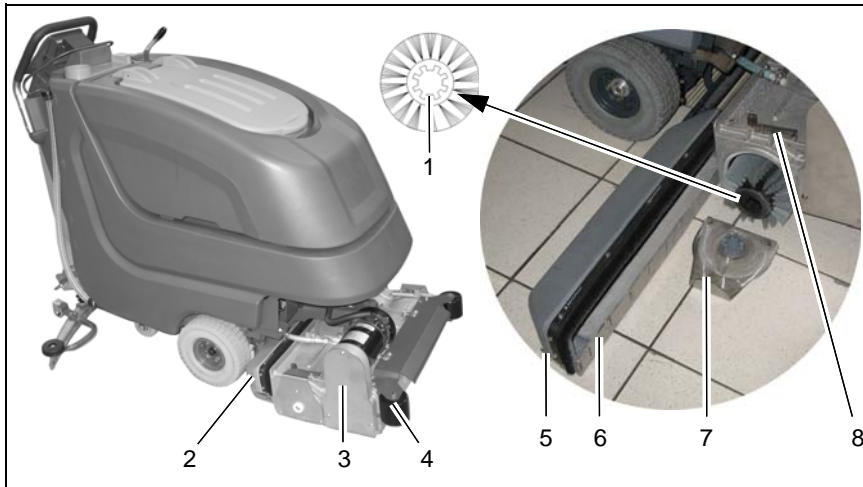

Fig.11

Maintenance and Care

5.9 Squeegee

- 1 Squeegee
- 2 Star-shaped knob
- 3 Eccentric wheel for angle adjustment
- 4 Suction hose
- 5 Fastening device
- 6 Washers for height adjustment

5.9.1 Cleaning the Squeegee

Check the squeegee (Fig. 12/1) daily and clean as necessary.

To clean it lift the squeegee out, pull off the suction hose (Fig. 12/4), loosen the two star-shaped knobs (Fig. 12/2) and remove the squeegee.

5.9.2 Changing the Sealing Strips

Check the inner and outer sealing strips on the squeegee (Fig. 12/1) weekly for signs of wear. The sealing strips can be used fourfold by turning them.

1. Lift the squeegee out.
2. Pull off the suction hose, loosen the two star-shaped knobs and remove the squeegee.
3. Unlock the fastening device (Fig. 12/5) and remove the outer sealing strip. Turn the sealing strip or install a new one, as necessary. Change the inner sealing strip in the same way.

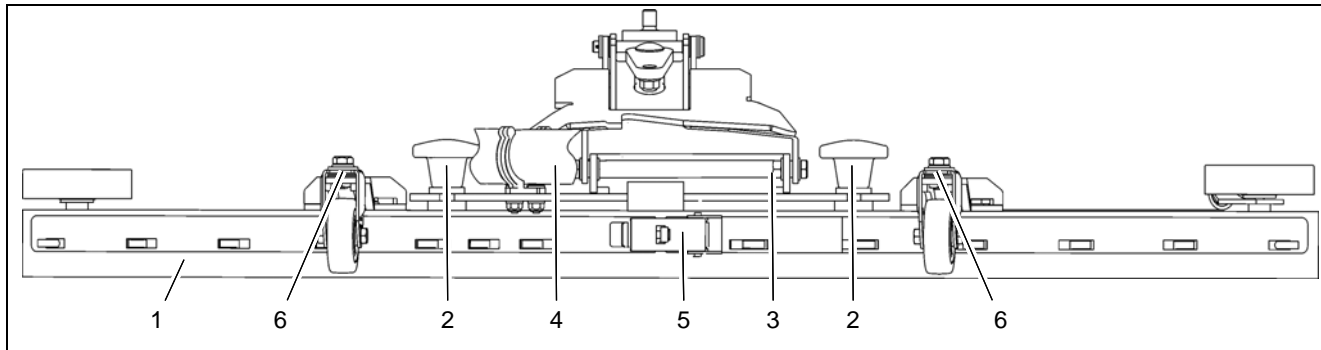

Fig.12

Maintenance and Care

5.9.3 Adjusting the Sealing Strips Angle Adjustment

The angle adjustment is the decisive factor in ensuring that the sealing strips on the squeegee lie evenly on the floor.

1. Park the machine on a level surface and lower the squeegee.
2. Loosen the screws on the eccentric wheel (Fig. 13/1) and adjust the squeegee using the eccentric wheel (SW13) so that the ends of the sealing strips still have contact with the floor.

Figure A: Turn the eccentric wheel in the front top position: The clearance between sealing strip and floor is reduced in the centre.

Figure B: Turn the eccentric wheel in the behind top position: The clearance between sealing strip and floor is increased in the centre.

3. Switch the machine on and check the suction pattern. When the machine is in operation, the entire surface of the sealing strips (centre and outer areas) must be applied as evenly as possible.
4. Tighten the screws on the eccentric wheel at 5 lb ft.

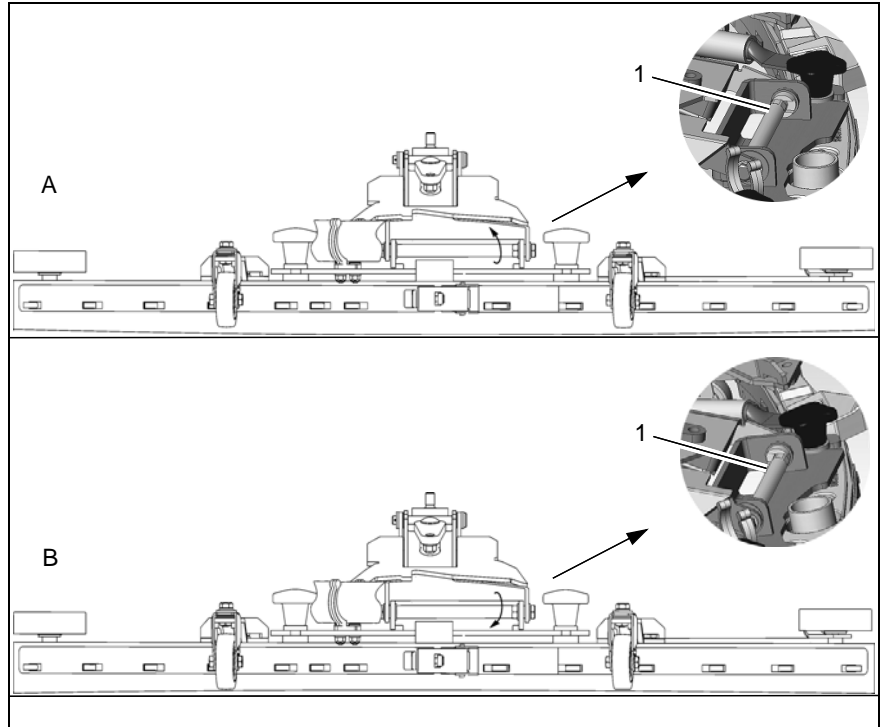

Fig.13

Maintenance and Care

Height Adjustment

The height adjustment is set to 3 mm at the factory. If streaks are produced, despite an optimum angle adjustment, the clearance between the rollers and floor must be adjusted by changing the number of washers on the holder.

In the case of very smooth floors, e.g. finished floors, PVC, linoleum, etc. Number of washers = 2. This corresponds to a clearance of approx. 2 mm.

In the case of very uneven floors, e.g. poorly laid tiles (water does not run off) Number of washers = 4. This corresponds to a clearance of approx. 4 mm.



The Squeegee 110 cm is equipped with two additional rollers which are adjusted at the factory to a distance of 10 mm to the floor by means of spacers.

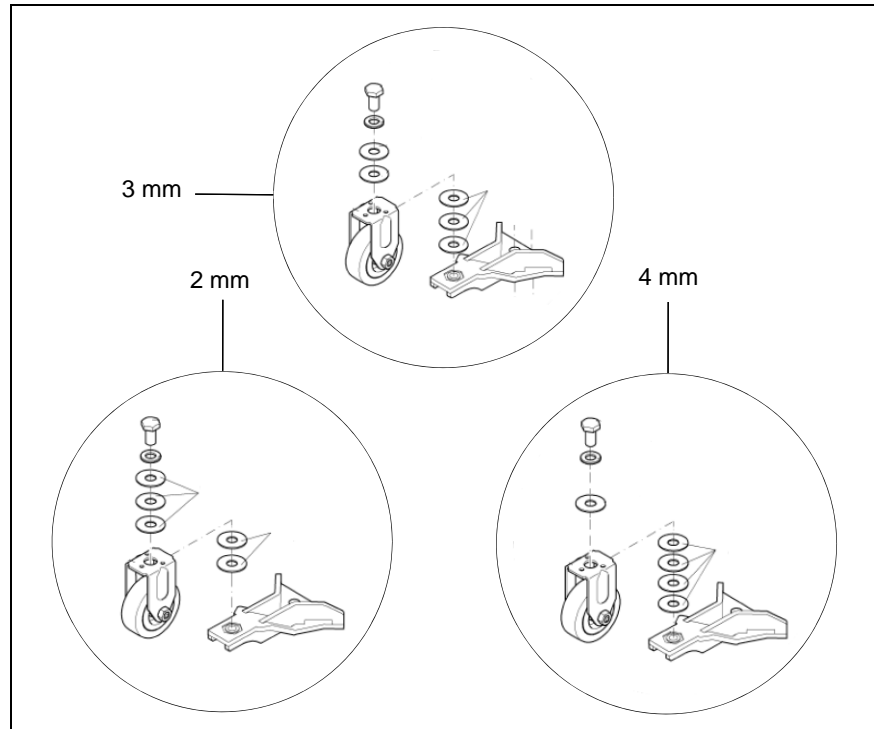

Fig.14

Maintenance and Care

Minuteman International Made Simple Commercial Limited Warranty

Minuteman International, Inc. warrants to the original purchaser/user that this product is free from defects in workmanship and materials under normal use. Minuteman will, at its option, repair or replace without charge, parts that fail under normal use and service when operated and maintained in accordance with the applicable operation and instruction manuals.

All warranty claims must be submitted through and approved by factory authorized repair stations.

This warranty does not apply to normal wear, or to items whose life is dependent on their use and care, such as belts, cords, switches, hoses, rubber parts, electrical motor components or adjustments. Parts not manufactured by are covered by and subject to the warranties and/or guarantees of their manufacturers. Please contact Minuteman for procedures in warranty claims against these manufacturers.

Special warning to purchaser -- Use of replacement filters and/or prefilters not manufactured by Minuteman or its designated licensees, will void all warranties expressed or implied.

A potential health hazard exists without original equipment replacement.

All warranted items become the sole property of Minuteman or its original manufacturer, whichever the case may be.

Minuteman disclaims any implied warranty, including the warranty of merchantability and the warranty of fitness for a particular purpose.

Minuteman assumes no responsibility for any special, incidental or consequential damages.

This limited warranty is applicable only in the U.S.A. and Canada, and is extended only to the original user/purchaser of this product. Customers outside the U.S.A. and Canada should contact their local distributor for export warranty policies. Minuteman is not responsible for costs or repairs performed by persons other than those specifically authorized by Minuteman. This warranty does not apply to damage from transportation, alterations by unauthorized persons, misuse or abuse of the equipment, use of non-compatible chemicals, or damage to property, or loss of income due to malfunctions of the product.

If a difficulty develops with this machine, you should contact the dealer from whom it was purchased.

This warranty gives you specific legal rights, and you may have other rights which vary from state to state. Some states do not allow the exclusion or limitation of special, incidental or consequential damages, or limitations on how long an implied warranty lasts, so the above exclusions and limitations may not apply to you.

Cord Electric Group	Three years parts, two years labor, ninety days travel (Not to exceed two hours)
Exceptions	Port-A-Scrub, one year parts, six months labor MPV 13, one year parts MPV 14 and 18, two years parts, one year labor Rapid Air blower, one year parts, one year labor Pneumatic Vacuums, three years parts, one year labor EX 12 and EX 12H, one year parts, one year labor
Battery Operated Group	Three years parts, two years labor, ninety days travel (Not to exceed two hours)
Exceptions	Sweepers, one year parts, one year labor, ninety days travel (Not to exceed two hours)
Replacement parts	Ninety days
Batteries	0-3 months replacement, 4-12 months pro-rate
Polypropylene Plastic Tanks	Ten years, no additional labor

Minuteman[®]

Excellence Meets Clean



Minuteman International Inc. • 111 South Rohlwing Road • ADDISON, IL. 60101-4244 U.S.A.
Telephone: 001-630-6276900 • Fax: 001-630-6271130

88-10-3006