



**Parts Manual
Max Ride 20 Floor Scrubber
Disc Brush Drive**

PREFACE

Thank you for your purchase of the new industry standard for scrubbers. Minuteman International takes great pride in offering the most dependable, reliable and best value in industrial power sweepers and sweeper / scrubbers. We set the standard.

Our Customer Service Department would like to hear from you. If you see any errors, omissions or something that needs clarification in this Parts Catalog please let us know. We are working hard towards continually improving our processes to bring you the best you deserve. Please copy the form below, fill out and comment on how you found our catalog.

Thank you!

The Minuteman International Team

Name: _____

Title: _____

Company Name: _____

Address: _____

Country: _____

Type of equipment or model number: _____

Comments: _____

Please return to:

Customer Service Manager
Minuteman International, Inc.
14N845 U.S. Route 20
Pingree Grove, Illinois 60140 USA

Phone: (800) 323-9420

Email: tech@minutemanintl.com

Technical Specifications

Model **Max Ride 20**
Models: MR20DQP, MR20DQPG, MR20DQPINT, MR20DQPT,
MR20DSQP, MR20DSQPG, MR20DSQPINT, MR20DSQPT

Model	MAX Ride 20
Scrub Head Type	Disc
Scrub Path	20 in (53 cm)
Solution Capacity	18 gal (68L)
Recovery Capacity	18 gal (68L)
Max Speed	3.1 mph (5 kh)
Max Productivity	27,200 sq. ft/hr (2527 sq m / hr)
Actual Productivity	22,015 sq. ft./ hr (2045 sq m / hr)
Brush Pressure	Floating- Locked-
Brush Speed	175-400 RPM
Brush Motor	400/600 watt
Vacuum Motor	550 watts
Vacuum Airflow	69 cfm (32.4L /sec)
Vacuum Waterlift	68" H2O (1717 mm H2O)
Sound Pressure	68 dba
Water Flow	.45 gpm (1.7 L / min)
Min. Turn-Around Aisle Width	50.5" (1283 mm)
Maximum Ramp Climbing	2%
Squeegee Width	25" (635mm)
Machine Voltage	24 VDC
Power Source	Battery (2) 12V 100/140 Ah
Battery Charger	On Board
Maximum Run Time	3-3.5 hrs.
Dimensions W/ Squeegee	47.5"L X 25.5"W X 45" H (1206mm X 648mm X 1143mm)
Weight Without Batteries	342 lbs (155 kg) No Solution
Weight With Batteries	691 lbs (313 kg) Full Solution and 140 AH battery pack
Approvals	None
IP Protection Class	IPX4

For Safety When Servicing or Maintaining Machine

- Stop on level surface.
- Disconnect the power to the machine by pulling the red Battery Connector located under the recovery tank near the batteries.
- Avoid moving parts. Do not wear loose jackets, shirts, or sleeves when working on machine.
- Avoid contact with battery acid. Battery acid can cause burns. When working on or around batteries, wear protective clothing and safety glasses. Remove metal jewelry. Do not lay tools or metal objects on top of batteries.
- Do not clean machine with a pressure washer.
- Authorized personnel must perform repairs and maintenance. Use Minuteman supplied replacement parts.

Table of Contents

Technical Specifications	3
Frame Group (Pg 1 of 2)	6
Frame Group (Pg 2 of 2)	7
Wheel Group	10
Tower Group	12
Tank Group (Pg 1 of 3)	14
Tank Group (Pg 2 of 3)	16
Tank Group (Pg 3 of 3)	18
Steering Column Group	20
Scrub Head Group	22
Scrub Head Lift Group	24
Squeegee Group	26
Squeegee Lift Group	28
Wiring Diagrams	30
Warranty	38

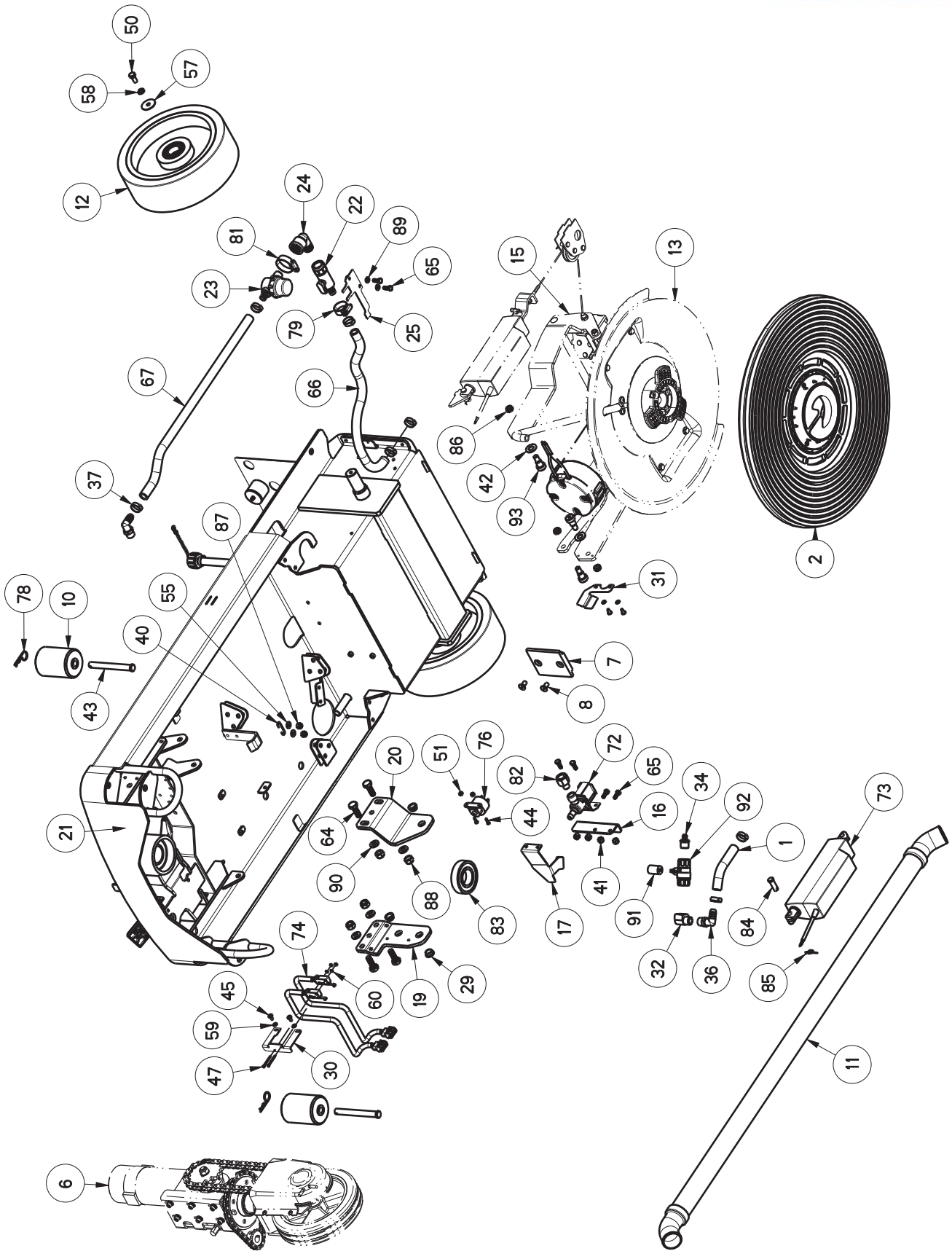

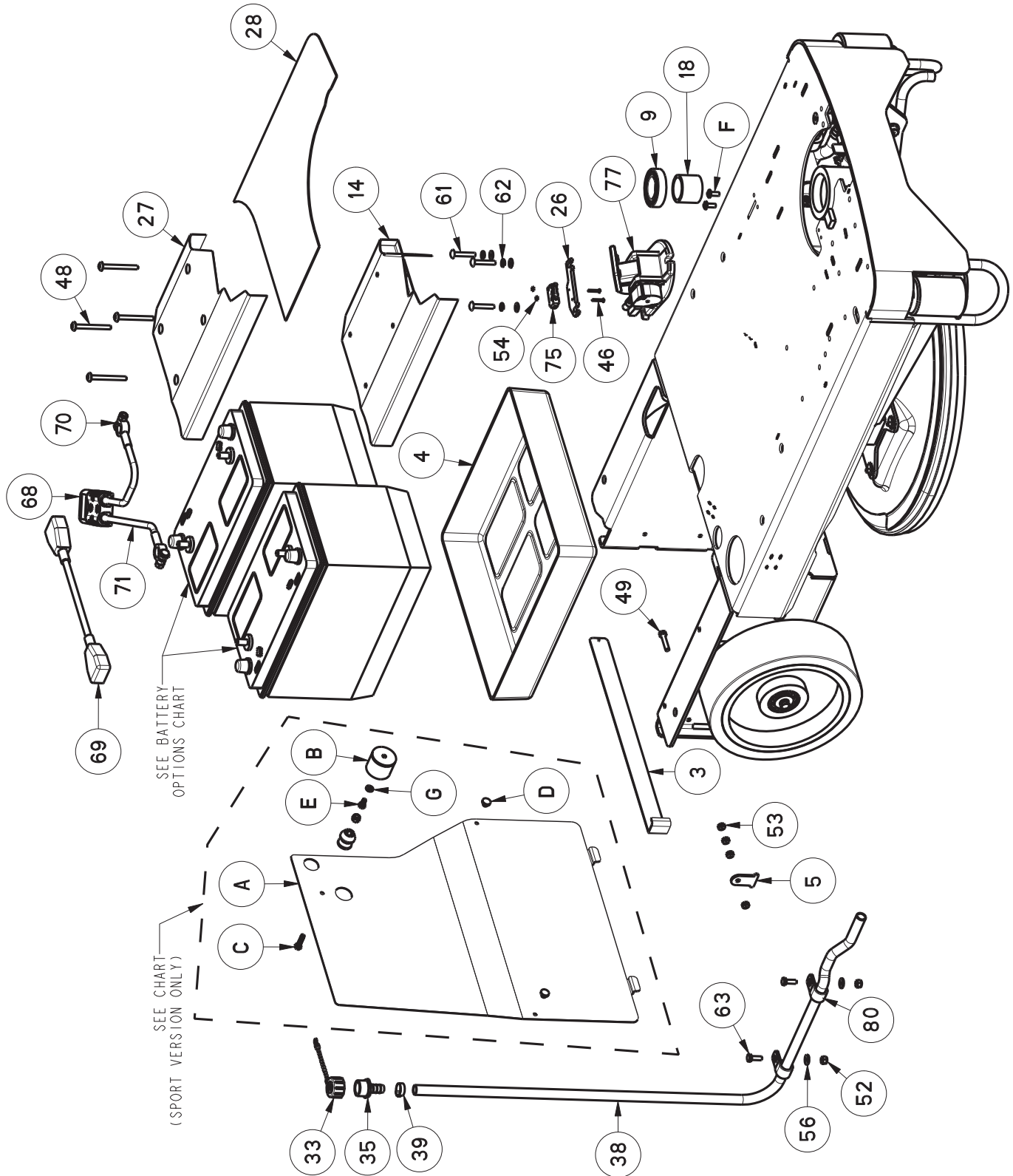

BILL OF MATERIAL - 245496							
ITEM	PART #	QTY	DESCRIPTION	ITEM	PART #	QTY	DESCRIPTION
1	172469	1	HOSE, NYLON 1/2 X 4.5 IN	31	245810	1	CAM - PLATE, LIMIT SWITCH, SCRUB-DECK
2	172520-2	1	PAD DRIVER, 20"	32	281088	1	FTG-ELBOW 90 ST 3/8 MPT x 3/8 FPT BRASS
3	245204	1	BATTERY BAR	33	283690	1	ASSY, BREATHER CAP W LANYARD
4	245210	1	BOX-BATTERY-MAX 20	34	320265	1	FTG-ADAPTER 3/8 MPT X 3/8 HB BRASS
5	245213	1	RETAINER-BATTERY BAR	35	342445	1	FTG-GARDEN ST 1/2 HB PP
6	245220	1	WHEEL DRIVE GROUP 20" & 26"	36	383337	2	FTG-ELBOW 90 3/8 MPT X 1/2 HB PP
7	245304	1	BLOCK, SLIDE	37	383347	7	CLAMP-CRIMP 1/2 HOSE
8	245338	2	SCR-FHSCS 5/16-18 X 5/8 SS	38	430231	1	HOSE, 1/2 ID X 45", CLEAR
9	245416	1	BALL BEARING 35MM X 62MM OD X 14MM W	39	450076	1	CLAMP-HOSE 5/8 (.590-.791) SS
10	245419	2	ROLLER, BUMPER, 2.5 DIA.	40	600125	1	CATCH, PARKING BRAKE
11	245450	1	HOSE-VAC, CLEAR 1.50"ID X 43 LONG	41	600933	6	NUT-NYLOC M6-1.00 SS
12	245461	2	WHEEL - ASSY, IDLER, 254 x 80 W/ BRGS	42	600950	2	WASHER-FLAT M12 ZP
13	245470	1	SCRUB HEAD GROUP 20	43	620027	2	PIN-CLEVIS 1/2 X 4.50 ZP
14	245475	1	WELDMENT,FLOOR PLATE RISER 20"	44	710204	2	SCR-PHMS 6-32 X .50 ZP
15	245488	1	SCRUB HEAD LIFT GROUP 20	45	710353	4	SCR-PHMS 10-32 X .37 ZP
16	245589	1	MOUNT, SOLUTION VALVE	46	710493	2	SCR-RHMS 4-40 X .75 ZP
17	245590	1	MOUNT, HAND VALVE	47	710495	2	SCR-PHMS 4-40 X 1.25 ZP
18	245592	1	SPACER, BEARING	48	710998	4	SCR-THMS 1/4-20 X 2.50 SS
19	245667	1	MOUNT, SCRUB HEAD RH 20"	49	711210	1	SCR-HH 1/4-20 X 1.25 ZP GR 5 FULL THRD
20	245668	1	MOUNT, SCRUB HEAD LH 20"	50	711227	2	SCR-HH 5/16-18 X .62 ZP GR 5
21	245670	1	WELDMENT, FRAME, 20"	51	711371	2	NUT-NYLOC 6-32 ZP
22	245780	1	VALVE- BALL 1/2 FPT X 1/2 HB	52	711373	2	NUT-NYLOC 1/4-20 ZP
23	245781	1	FILTER - 1/2 MPT X 1/2 HB	53	711387	4	NUT-JAM 1/4-20 ZP NYLOC
24	245783	1	FTG-ELBOW STREET 90 1/2 MPTX1/2FPT BLKPP	54	711428	4	NUT-HEX 4-40 ZP
25	245784	1	PLATE - MTG - BALL VALVE AND FILTER	55	711504	5	WASHER-FLAT 1/4 SS
26	245793	1	PLATE, LIMIT SW MNT, @ PEDAL	56	711505	2	WASHER-FLAT 1/4 ZP
27	245796	1	TREAD, ANTI-SKID, RISER 20"	57	711516	2	WASHER-FLAT 5/16 X 1.25 X .05 ZP
28	245797	1	TREAD, ANTI-SKID, FRAME 20"	58	711545	2	WASHER-LOCK 5/16 SPLIT ZP
29	245806	3	BUSHING-FLG, .50 x .62 x .31 LG OILITE	59	711553	4	WASHER-INT TOOTH LOCK #10 ZP
30	245809	1	BRACKET - MTG, LIMIT SWITCH, SCRUBDECK	60	712326	2	WASHER-INT LOCK #4 SS

BILL OF MATERIAL - 245496							
ITEM	PART #	QTY	DESCRIPTION	ITEM	PART #	QTY	DESCRIPTION
61	712569	3	SCR-THMS 1/4-20 X 1.50 SS	78	833374	2	PIN-HAIRPIN COTTER 3/8
62	712758	3	WASHER-LOCK 1/4 SPLIT SS	79	3300535	1	CLAMP-HOSE 1.00 NOM
63	713002	2	SCR-HH 1/4-20 X .75 ZP 5	80	3301158	2	CLAMP-CABLE 11/16" DIA
64	730878	4	SCR-HH M10-1.50 X 30 SS	81	3302193	1	CLAMP-HOSE 1.25 NOM
65	730934	8	SCR-HH M6-1.00 X 16 SS FULL THRD	82	3303302	1	FTG-REDUCER 3/8 FPT X 1/4 MPT
66	730971	1	TUBING, .50 ID X 18.5 IN	83	3305667	1	BEARING-MAIN BROOM
67	731544	1	TUBING, .50 ID X 22 IN	84	3400117	1	PIN-CLEVIS 3/8 x 1.125 ZP
68	740159	1	CONNECTOR-SB175 RED HOUSING	85	3400125	1	RING-RUE 3/8
69	740164-1	1	CBL ASSY- BATT. JMPR, 4G RED 12"	86	3401028	3	NUT-JAM 3/8-16 ZP NYLOC
70	740167	1	BATT. CABLE, RED 4AWG SB175	87	12040044	3	NUT-NYLOC M6 X 1.0 ZP CLASS 6
71	740168	1	BATT. CABLE, BLACK 4AWG SB175	88	12040069	4	NUT-NYLOC M10 X 1.5 ZD CLASS 6
72	740493	1	VALVE-WATER 24VDC	89	12310033	3	WASHER-FLAT M6.4 X 12 X 1.6 ZP
73	740827-1	1	ACTUATOR - 40MM STROKE- 750 N FORCE TERM	90	12310058	4	WASHER-FLAT M10.5 X 20 X 2 ZP
74	747603-2	2	SWITCH ASY, MICRO ROLLER W/ PACK/CONDUIT	91	90502428	1	SHAFT CONNECTOR
75	747604	1	SWITCH, MICRO .96" ROLLER ARM	92	90521576	1	BALL VALVE
76	748200	1	HORN / BACK UP ALARM, 9-48VDC	93	712099PLT	3	BLT-SHLDR 1/2 X 1/2 LG X 3/8-16
77	748507	1	PEDAL ASSY, THROTTLE, FLOOR MTG 25°, IEC				

BATTERY OPTIONS		
MODEL	PART NO.	DESCRIPTION
MR20DQPG, MR20DSQPG	956158	BATTERY 12V 140AH OVERDRIVE 12AGM
MR20DQPT, MR20DSQPT	956753	BATTERY WET 12V 130AH TROJAN
MR20DQP, MR20DQPINT	956712	BATTERY, 12V 115 AH WET
MR20DSQP, MR20DSQPINT	956140	BATTERY, 12V 140AH WET

SPORT VERSIONS ONLY							
ITEM	PART NO.	QTY	DESCRIPTION	ITEM	PART NO.	QTY	DESCRIPTION
A	245212	1	COVER, REAR 20"	E	11038064	1	BLT-HH M6 X 1.0 X 12 STL ZD 8.8
B	245222	1	LATCH-RUBBER	F	11177060	2	SC-BHCS W/ FLANGE M6 X 1.0 X 16 304SS
C	731006	1	SCR-HH M6-1.00 X 25 ZP CLASS 8.8	G	12310033	1	WASHER-FLAT M6.4 X 12 X 1.6 ZP
D	3300526	2	BUMPER-RUBBER 1/4 ID X 1/8 THK				

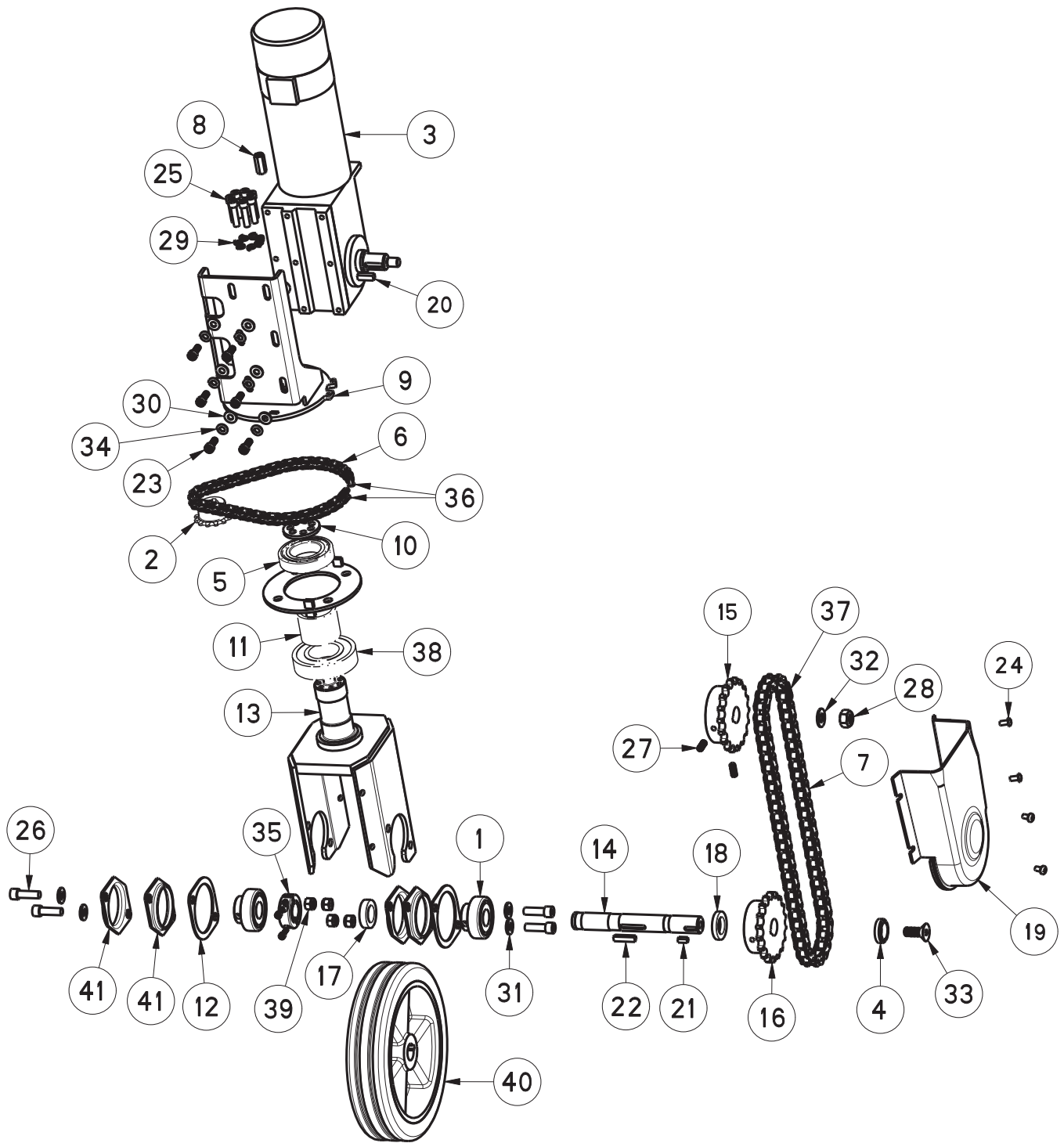

Wheel Group BOM

BILL OF MATERIAL - 245220				
ITEM	PART NO.	QTY	DESCRIPTION	NOTES
1	66-138-A	2	BEARING	
2	245087	1	SPROCKET, ROLLER CHAIN 35FB13 - 5/8"BORE	SHOWN IN TOWER GROUP 245502
3	245184	1	GEAR-MOTOR, TRACTION, 24VDC 700W, ASI	
4	245273	1	WASHER, END-OF-SHAFT, 3/8 FL HD	
5	245416	1	BALL BEARING 35MM X 62MM OD X 14MM W	SHOWN IN FRAME GROUP 245496
6	245445-1	1	CHAIN - ROLLER #35 - 23 LINKS	
7	245446-1	1	CHAIN - ROLLER #40 - 31 LINKS	
8	245562	1	NUT, COUPLING, 1/4-20 X 7/8 ZINC	
9	245564	1	WELDMENT, STEERING RING	
10	245579	1	DISC, STEERING PLT	
11	245592	1	SPACER, BEARING	SHOWN IN FRAME GROUP 245496
12	245594	2	SPACER, BEARING	
13	245595	1	WELDMENT, FORK	
14	245760	1	SHAFT, TRACTION WHEEL	
15	245785	1	SPROCKET - CHAIN, 40B19 MINIMUM BORE	
16	245786	1	SPROCKET - CHAIN, 40B18 3/4" BORE	
17	245787	1	SLEEVE, SPACER, .755 ID 1.25 OD .321 LG	
18	245788	1	SLEEVE, SPACER, .755 ID 1.25 OD .216 LG	
19	245790	1	COVER - CHAIN, TRACTION	
20	245811	1	KEY-6mm X 6mm X .75	
21	245813	1	KEY-3/16 X 3/16 X 7/16	
22	245815	1	KEY-STEPPED, 3/16 X 6MM X 1.0"	
23	600912	6	SCR-SHCS M6-1.00 X 16 ZP	
24	710353	4	SCR-PHMS 10-32 X .37 ZP	
25	710826	7	SCR-SHCS 1/4-20 X 1.00 SS	
26	710857	4	SCR-SHCS 5/16-24 X 1.00 BLL OX	
27	711006	2	SCR-SET 1/4-20 X .62 BLK OX CP	
28	711417	1	NUT-NYLOC M10 x 1.25 ZP	
29	711421	7	WASHER-LOCK 1/4 SPLIT, HIGH-COLLAR, SS	
30	711504	6	WASHER-FLAT 1/4 SS	
31	711506	4	WASHER-FLAT 5/16 X .688 ZP	
32	711515	1	WASHER-FLAT 3/8 X .812 X .0625 ZP	
33	712519	1	SCR-FHSCS 3/8-24 X 1.00 ZP	
34	712758	6	WASHER-LOCK 1/4 SPLIT SS	
35	713532	1	COLLAR, CLAMP 2-PIECE, 11/16 B x 1/2" W	
36	833292	2	CHAIN MASTER LINK #35	
37	833629	1	CHAIN MASTER LINK #40	
38	3305667	1	BEARING-MAIN BROOM	SHOWN IN FRAME GROUP 245496
39	3400420	4	NUT-NYLOC 5/16-24 ZP	
40	90538117	1	WHEEL, 200 X 45 X 19 ID, URETHANE	
41	340742MCH	4	FLANGE MACHINED	

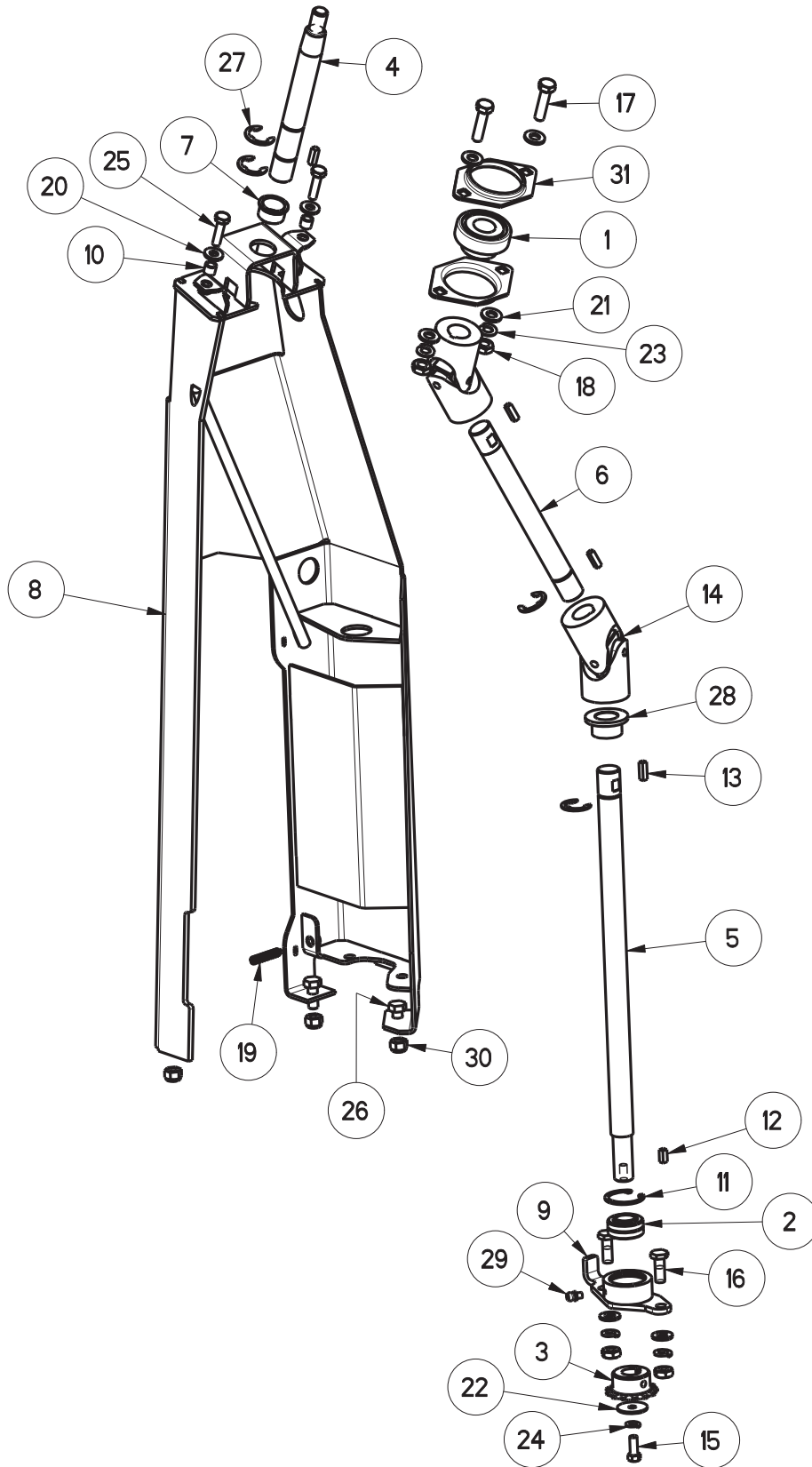

BILL OF MATERIAL - 245502			
ITEM	PART NO.	QTY	DESCRIPTION
1	66-138-A	1	BEARING
2	245085	1	BEARING, SPHERICAL 5/8"ID X 1.187"OD
3	245087	1	SPROCKET, ROLLER CHAIN 35FB13 - 5/8"BORE
4	245099	1	SHAFT, STEERING WHEEL MTG
5	245101	1	SHAFT, STEERING LOWER, PINION SPROCKET
6	245102	1	SHAFT, STEERING, MID - FLOATING
7	245199	1	BUSHING-FLG, .75 x .88, x .50 LG OILITE
8	245550	1	WELDMENT, TOWER
9	245580	1	WELDMENT, TENSIONER
10	245583	2	SPACER, .266 B, .313 OD, .313 T
11	245584	1	RETAINING RING, INT, 1.188 ZP
12	245813	1	KEY-3/16 X 3/16 X 7/16
13	245814	4	KEY-3/16 X 3/16 X 5/8
14	383098	2	JOINT-UNIVERSAL 3/4"
15	711203	1	SCR-HH 1/4-20 X .62 ZP TAP
16	711229	2	SCR-HH 5/16-18 X .87 ZP GR 5
17	711231	2	SCR-HH 5/16-18 X 1.25 ZP GR 5 FULL THREA
18	711319	4	NUT-HEX 5/16-18 ZP
19	711489	1	SCR-SET 1/4-20 x 1.25 DOG POINT BLACK
20	711505	2	WASHER-FLAT 1/4 ZP
21	711506	6	WASHER-FLAT 5/16 X .688 ZP
22	711519	1	WASHER-FLAT 1/4 X 1.00 X .06 ZP
23	711545	4	WASHER-LOCK 5/16 SPLIT ZP
24	712758	1	WASHER-LOCK 1/4 SPLIT SS
25	713003	2	SCR-HH 1/4-20 X 1.00 ZP GR 5
26	717024	3	SCR-HH M8-1.25 X 20 ZP GRADE 8.8
27	809148	4	RET RING-E TYPE .75
28	832554	1	BUSHING-FLG .7505 X 1.437 X .625 BRNZ
29	3400012	1	FTG-GREASE 3/16
30	12040051	3	NUT-NYLOC M8 X 1.25 ZP CLASS 8
31	340742MCH	2	FLANGE MACHINED

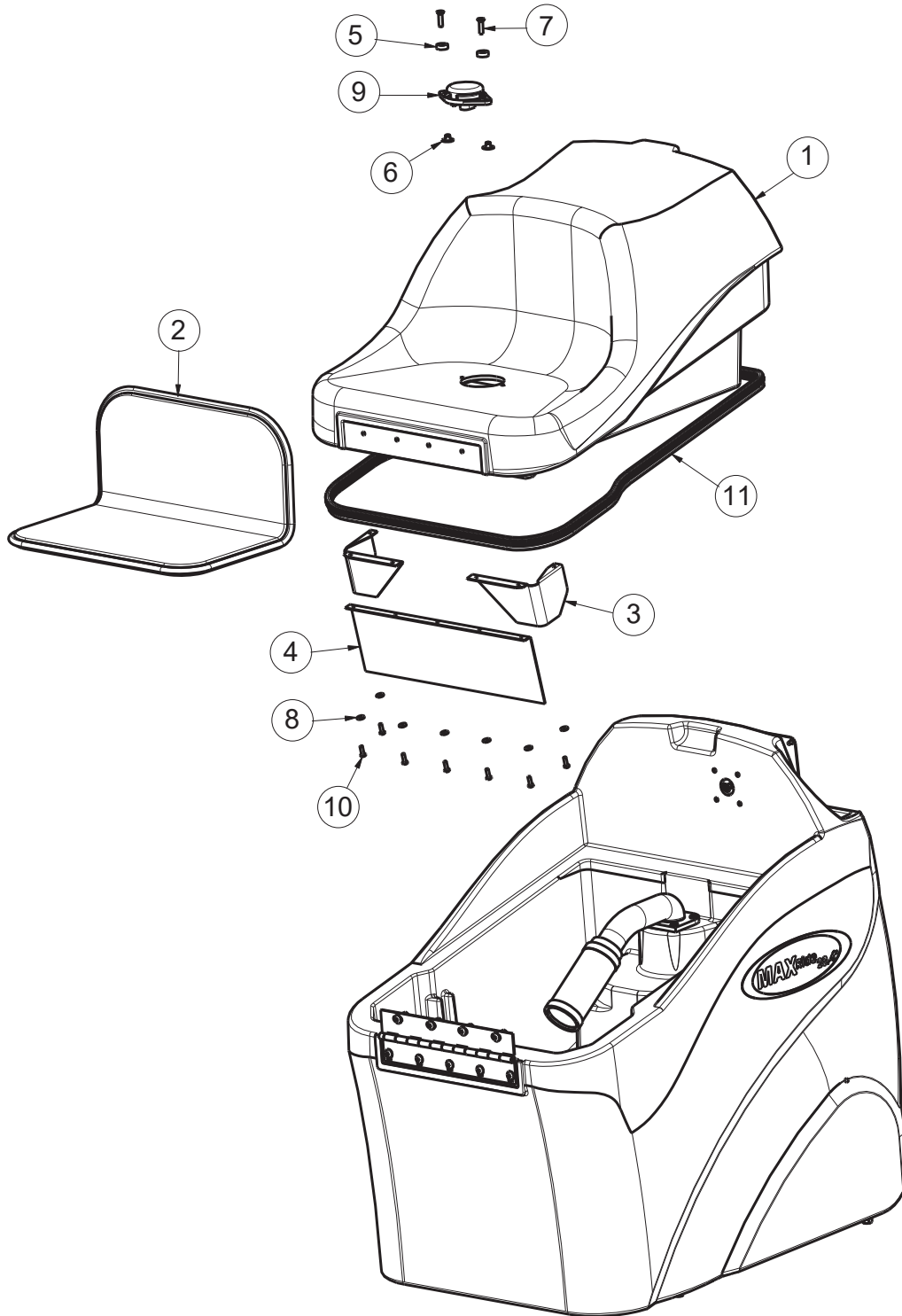

BILL OF MATERIAL - 245487			
ITEM	PART NO.	QTY	DESCRIPTION
1	245002	1	LID W/ SEAT, TANK, ER20-V
2	245444	1	SEAT-CUSHIONED, SEWN SEAT & BACK
3	245766	2	SKIRT-DRIP, LID, END PIECE
4	245767	1	SKIRT-DRIP, LID,CENTER 20"
5	245817	2	SPACER, .39 ID X .75 OD X .25 T, PVC
6	711491	2	NUT-TEE, PROPELL INSERT 1/4-20 X 5/16 ZP
7	712153	2	SCR-FHSCS 1/4-20 X 1.00 SS
8	712764	19	WASHER-FLAT #10 SS
9	740601	1	SWITCH, SEAT, BOLT MOUNT
10	3401449	11	SCR-HI/LO 10 X .75 SS PAN HD
11	25510512	1	GASKET, RUBBER BLADE, PRESS IN

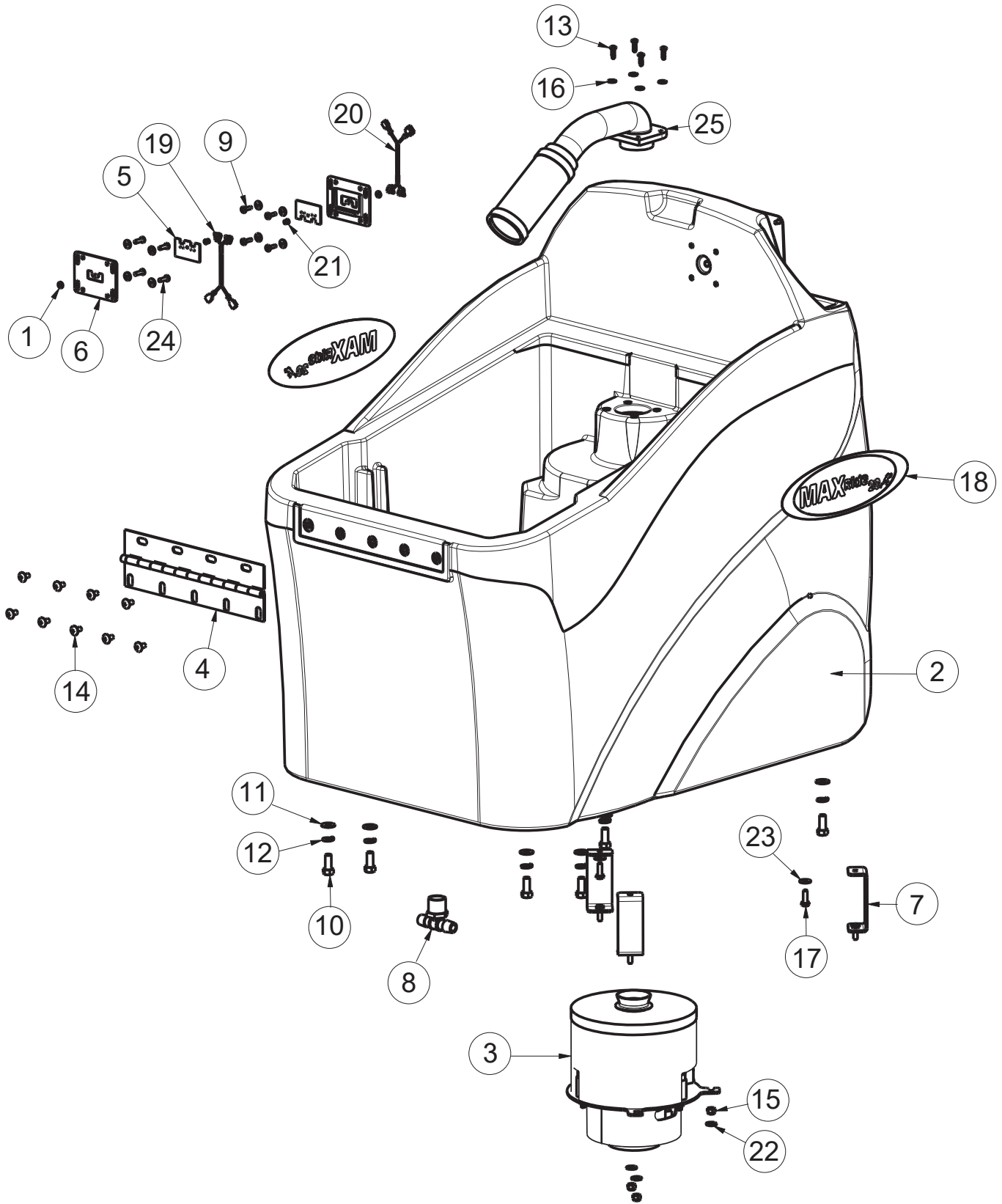

BILL OF MATERIAL - 245487			
ITEM	PART NO.	QTY	DESCRIPTION
1	950-4-S	2	BACK UP PLATE 1/8" STEEL
2	245001	1	TANK, SOLUTION & RECOVERY ER20-V
3	245234	1	ASSY, VACUUM & HOUSING
4	245422	1	HINGE, STEEL, 11.38" LONG PAINTED
5	245453	2	PLATE - INSERT, INTERCONNECT
6	245456	2	PLATE - BASE, INTERCONNECT
7	245663	3	WELDMENT, VAC MOTOR PILLAR
8	342440	1	FTG-TEE 3/4 MPT X 1/2 HB NYLON
9	710130	4	SCR-THMS 8-32 X .62 SS
10	711246	6	SCR-HH 3/8-16 X .87 ZP GR 5
11	711515	6	WASHER-FLAT 3/8 X .812 X .0625 ZP
12	711546	6	WASHER-LOCK 3/8 SPLIT ZP
13	712536	10	SCR-THMS 10-24 X .62 SS
14	712560	9	SCR-THMS 1/4-20 X .50 SS W/NYLON PATCH
15	712667	3	NUT-NYLOC 1/4-20 SS
16	712764	19	WASHER-FLAT #10 SS
17	713002	3	SCR-HH 1/4-20 X .75 ZP 5
18	715977	2	DECAL, MAIN OVAL MAX-RIDE 20, ER V-20
19	747349	1	WIRE ASSY, SEAT SWITCH
20	747350	1	WIRE ASSY, SEAT SW CONN
21	827666	2	RIVET-POP 1/8 DOME HD, BLK ALUM BODY
22	3400089	3	WASHER-FLAT 1/4 ZP
23	3400383	3	WASHER-CONICAL SPRING 1/4
24	3401449	11	SCR-HI/LO 10 X .75 SS PAN HD
25	97118731	1	FILTER UNIT, SCREENED FLOAT

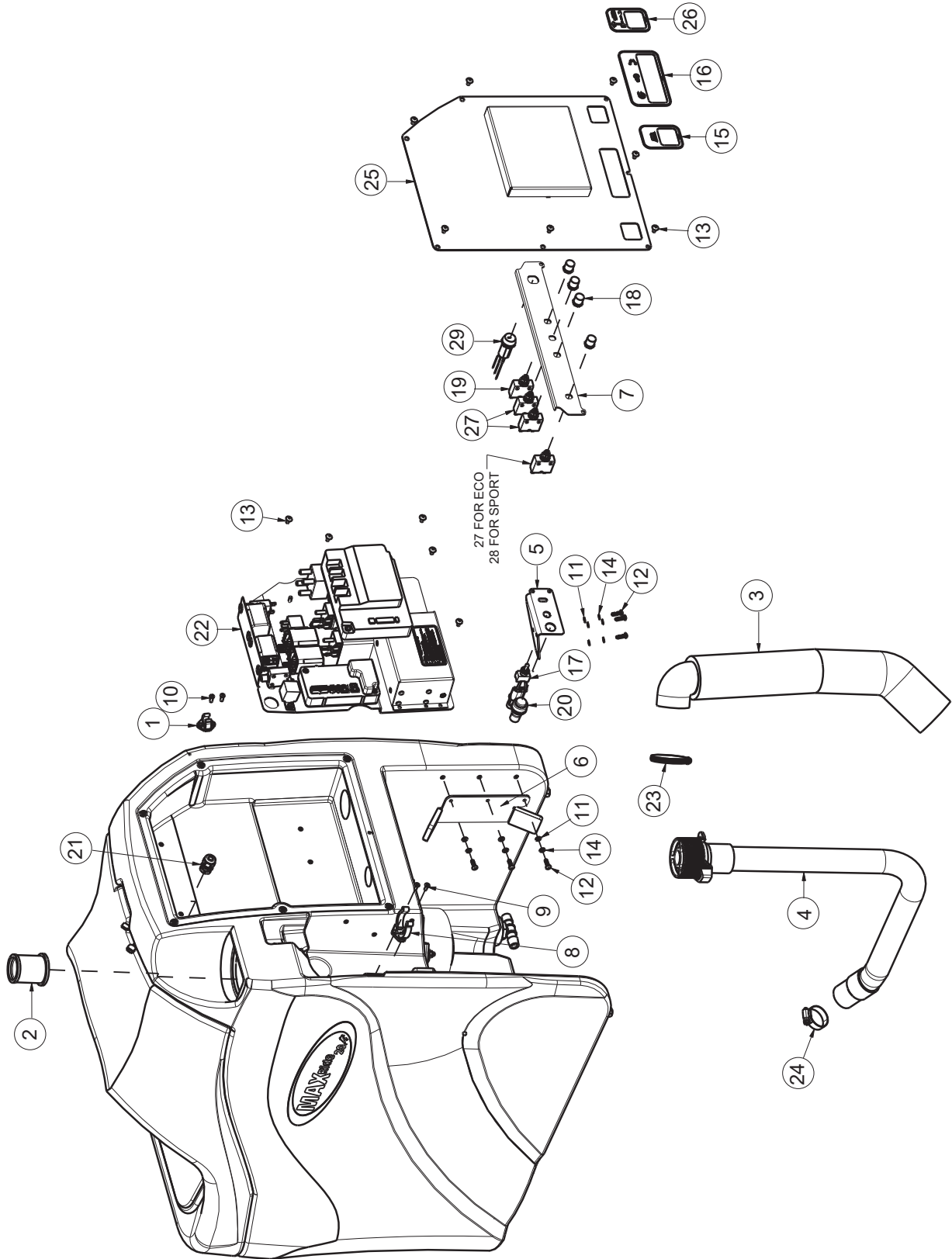

BILL OF MATERIAL - 245487			
ITEM	PART NO.	QTY	DESCRIPTION
1	172065	1	CLIP, FOR 1/2" ID HOSE
2	172159	1	FILTER, FILL PORT, ES1720
3	241049	1	MUFFLER-VAC MOTOR, SCV 24/26
4	245452	1	HOSE-DRAIN W/CAP 1.50"ID, 30.5"L
5	245660	1	BRACKET - MTG, REAR COVER LATCH & ELEC
6	245794	1	HOLDER - CORD, W/ SOFT CAPS, BATT CHARGR
7	245902	1	BRACKET, BREAKER MOUNT 20"
8	260579	1	CLIP-TOOL 1.5 INCH HOSE
9	710530	2	SCR-FHMS 8-32 X .50 BRASS
10	711163	2	SCR-HI/LO 10 X .50 BLACK ZINC PAN HD
11	711502	6	WASHER-FLAT #8 ZP
12	340742MCH	2	FLANGE MACHINED
13	712540	12	SCR-THMS 10-24 X .37 SS
14	712770	6	WASHER-INT TOOTH LOCK #10 SS
15	715534	1	DECAL, BRUSH MOTOR, MAX RIDE 20
16	715535	1	DECAL, VACUUM-DRIVE MOTOR-POWER
17	740188-3	1	SWITCH, TOGGLE W/FEM PACK
18	742748	4	CIRCUIT BREAKER-BOOT
19	747609	1	CIRCUIT BREAKER-4.0AMP PUSH BUTTON
20	747614	1	INDICATOR, BATTERY CHARGE STATUS (E1720)
21	747689	1	STRAIN RELIEF CABLE DIA. .181-.312 #3210
22	748515	1	ASSY, ELECTRICAL PANEL, 20/26
23	3044112	1	CLAMP-HOSE, SS, 2.50 MAX WORM
24	3303255	1	CLAMP-HOSE 1.75 DIA NOMINAL
25	245906	1	COVER, ELEC BOX, ECO 20"
	245905		COVER, ELEC BOX, SPORT 20"
26	715533	1	DECAL, 2 POSITION SWITCH, BRUSH MOTOR (<i>SPORT ONLY</i>)
27	740247	3	CIRCUIT BREAKER-30AMP PUSH BUTTON
28	740549	1	CIRCUIT BREAKER-50AMP PUSH BUTTON (<i>SPORT ONLY</i>)
29	747717	1	KEYSWITCH ASSY, 2 POS, ON/OFF (<i>SPORT ONLY</i>)

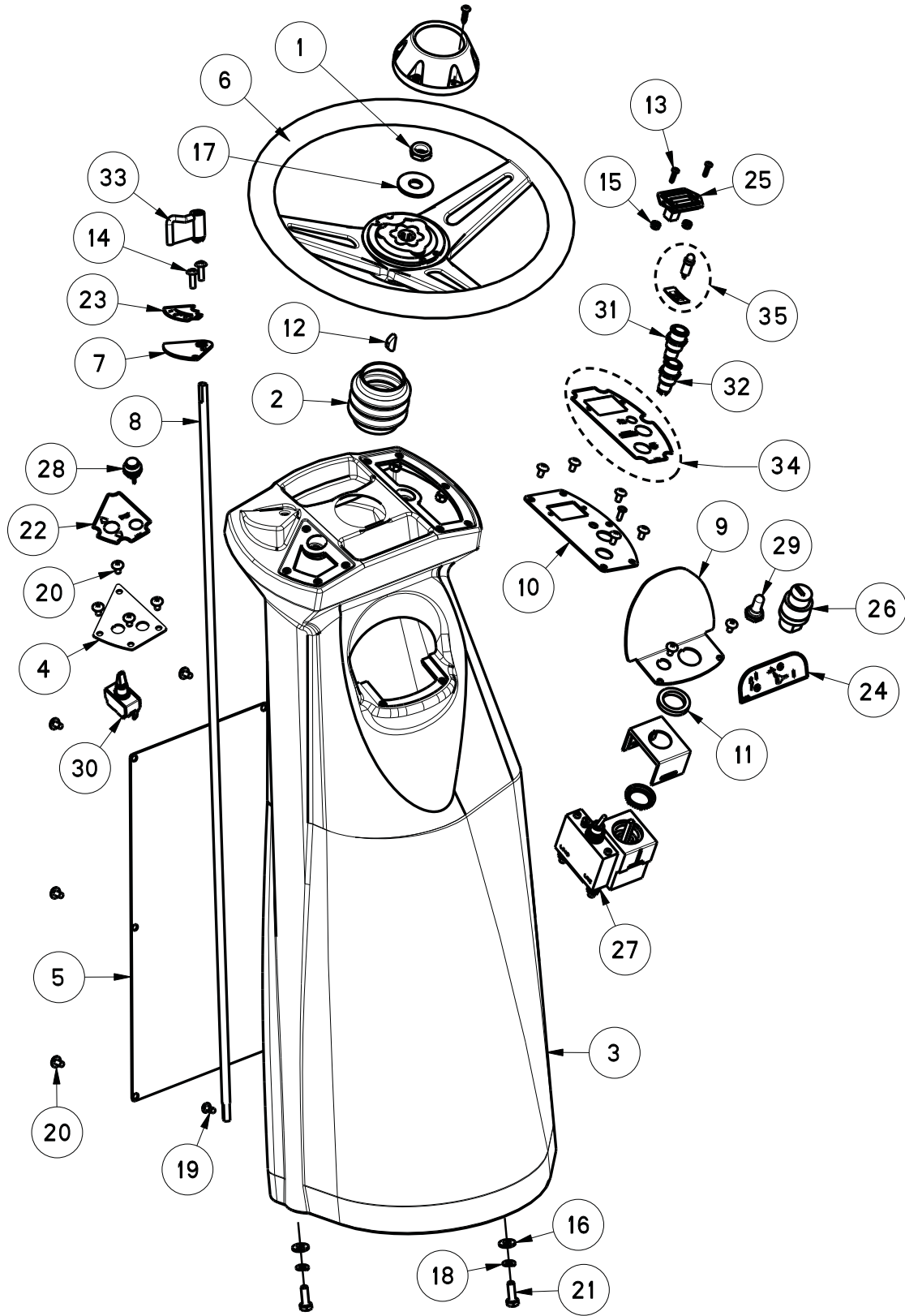

BILL OF MATERIAL - 245472			
ITEM	PART NO.	QTY	DESCRIPTION
1	368-816	1	NUT-NYLOC HALF 1/2-20 ZP
2	241224	1	BOOT - STEERING SHAFT, SCV 2426
3	245003	1	CONSOLE, STEERING ER2026-V
4	245028	1	PANEL-CONTROL, LH FWD-REV SLCTR ASSY
5	245156	1	PANEL-FRONT, STEERING CONSOLE, ER20/26-V
6	245345	1	STEERING WHEEL- 12.75"
7	245447	1	PLATE, WATER FLOW LEVER
8	245448-1	1	ROD, WATER FLOW LEVER, FINISHED
9	245688	1	PANEL, CENTER, KEY SWITCH & C.B.
10	245801	1	PANEL-CONTROL RH, FUNCTION SELECT, SPORT
11	245802	1	SPACER, PVC, KEY SWITCH, .188 THK
12	383277	1	KEY-WOODRUFF 3/16 X .750
13	710203	2	SCR-PHMS 6-32 X .37 ZP
14	711160	2	SCR-HI/LO 10 X .625 BLACK ZINC
15	711371	2	NUT-NYLOC 6-32 ZP
16	711505	2	WASHER-FLAT 1/4 ZP
17	711510	1	WASHER-FLAT 1/2 X 1.37 X .10 ZP
18	711544	2	WASHER-LOCK 1/4 SPLIT ZP
19	711923	2	RIVET-POP 3/16
20	712540	17	SCR-THMS 10-24 X .37 SS
21	713002	2	SCR-HH 1/4-20 X .75 ZP 5
22	715762	1	DECAL-FWD-REV SELECTOR MAX RIDE
23	715764	1	DECAL-WATER FLOW
24	715777	1	DECAL, CENTER PANEL, KEY SWITCH-C.B.
25	747011	1	GAUGE-BATTERY TRUCHARGE PGDT 36VDC
26	747387	1	KEYSWITCH ASSY, SWITCH+WIRES MR
27	748012	1	CIRCUIT BREAKER- 100A
28	748047	1	SWITCH, PUSH BUTTON (HORN SCV 36V)
29	748508	1	TOGGLE BOOT, FULL, OPEN THROAT, RED
30	748800	1	SWITCH-TOGGLE G SERIES NYL SPDT ON/ON
31	748803	1	SWITCH, PUSH BUTTON, BLUE LED
32	748804	1	SWITCH, PUSH BUTTON, ORANGE LED
33	90502436	1	LEVER, SOLUTION CONTROL
34	715775	1	DECAL-FUNCTION SELECTOR MAX RIDE (ECO)
	715776		DECAL, FUNCTION SELECTOR, (SPORT)
35	747718	1	LAMP ASSY, LED AMBER, 24V (SPORT ONLY)
	747718-2		CLIP, TINNEMAN (SPORT ONLY)

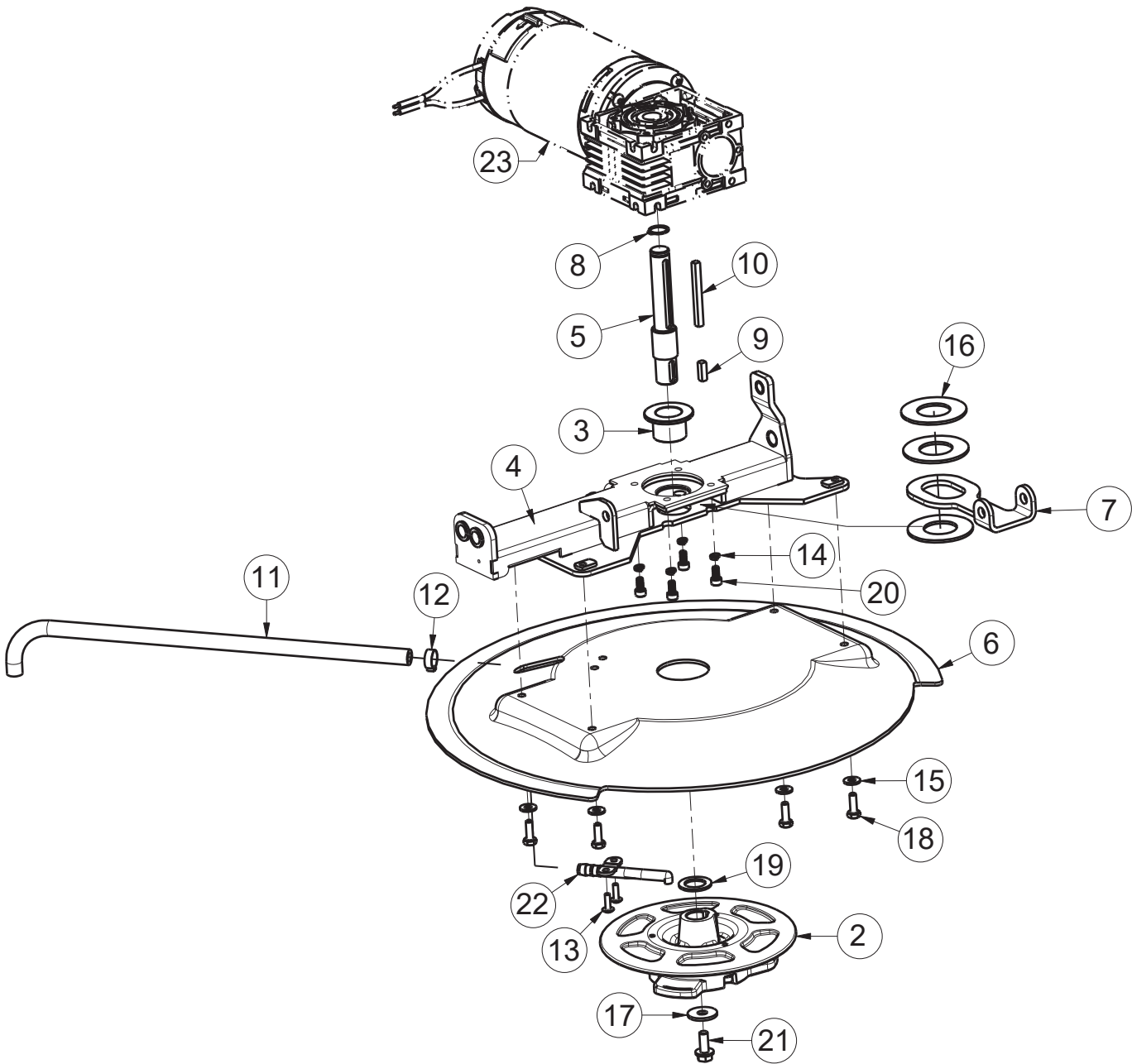

BILL OF MATERIAL - 245470			
ITEM	PART NO.	QTY	DESCRIPTION
1	000712	1	LOCTITE-243 50ML BLUE
2	172510	1	HUB ASSEMBLY, DISC DECK
3	245042	1	BUSHING-FLG, 1.0 x 1.25 x 1.0"LG OILITE
4	245105	1	WELDMENT,SCRUBDECK, 20"
5	245107	1	SHAFT - STUB, RT-ANGLE DRIVE, DISC BRUSH
6	245300	1	COVER, SCRUB HEAD 20"
7	245312	1	RING, PIVOT
8	245468	1	RET RING-EXT .687 BLK OXIDE
9	245811	1	KEY-6mm X 6mm X .75
10	245812	1	KEY-6mm X 6mm X 2.625
11	283153	1	HOSE 3/8" ID X 16.5"
12	452037	1	CLAMP-CRIMP 170R SS
13	710154	2	SCR-THMS 10-32 X .625 SS
14	711421	4	WASHER-LOCK 1/4 SPLIT, HIGH-COLLAR, SS
15	711505	4	WASHER-FLAT 1/4 ZP
16	711687	3	WASHER-FLAT, 2.50 OD X 1.28 ID X .095 ZP
17	711855	1	WASHER-FENDER 3/8 X 1.12 X .10 ZP HARD
18	713002	4	SCR-HH 1/4-20 X .75 ZP 5
19	717025	1	WASHER-FLAT 13/16 X 1.25 X .08 ZP
20	3402054	4	SCR-SHCS M6-1.0 X 12 ZP
21	11717203	1	BLT-HH FLG M8X1.25X20 PRECOTE, ZD 10.9
22	90311663	1	FITTING, WATER NOZZLE W/ MOUNT HOLES
23	245808	1	GEAR - MOTOR, BRUSH, 24VDC 400W, AMER (<i>ECO</i>)
	245231		GEAR-MOTOR, BRUSH, 24VDC 600W, AMER (<i>SPORT</i>)

Scrub Head Lift Group

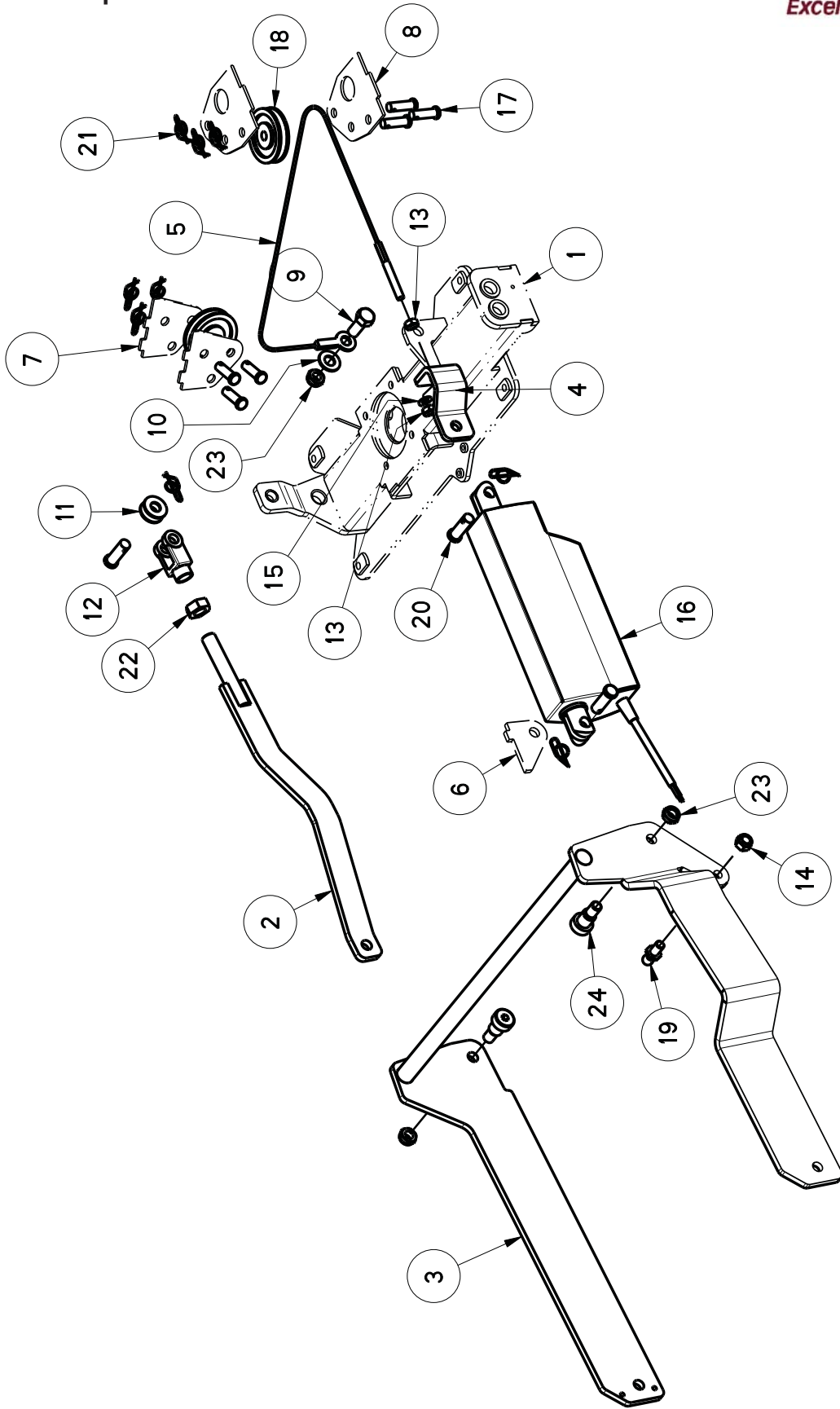

Scrub Head Lift Group BOM



BILL OF MATERIAL - 245488				
ITEM	PART NO.	QTY	DESCRIPTION	NOTES
1	245105	1	WELDMENT,SCRUBDECK, 20"	SHOWN IN SCRUB HEAD GROUP 245470
2	245138	1	WELDMENT, DECK ADJ LINK 20"	
3	245281	1	WELDMENT, SCRUBHEAD ARM 20	
4	245298	1	LINK, CABLE	
5	245314	1	CABLE- SCRUB DECK MR20	
6	245538	1	W/D, FRAME, ACT MNT	PART OF ITEM 245670 IN FRAME GROUP 245496
7	245540	2	W/D, FRAME, PULLEY MNT 2	PART OF ITEM 245670 IN FRAME GROUP 245496
8	245679	2	W/D, FRAME, PULLEY MNT 5	PART OF ITEM 245670 IN FRAME GROUP 245496
9	711246	1	SCR-HH 3/8-16 X .87 ZP GR 5	
10	711515	1	WASHER-FLAT 3/8 X .812 X .0625 ZP	
11	711569	2	WASHER-FLAT .390 X .880 X .062 NYL	
12	712265	1	CLEVIS-YOKE, 1/2-20 WITH .375 PIN	
13	712665	2	NUT-HEX 1/4-20 SS	
14	712683	1	NUT-NYLOC 5/16-18 SS	
15	712758	1	WASHER-LOCK 1/4 SPLIT SS	
16	740822-1	1	ACTUATOR ASSYW/ PK-100MM STROKE 750N CE	
17	881002	6	PIN-CLEVIS 5/16 X 1.00 ZINC	
18	3300368	2	PULLEY-PLASTIC 2" x .25" GROOVE	
19	3300376	1	STUD-BALL GAS SPR 5/16-18 THRD .391DIA.	
20	3400117	3	PIN-CLEVIS 3/8 x 1.125 ZP	
21	3400125	9	RING-RUE 3/8	
22	3400449	1	NUT-JAM 1/2-20 ZP	
23	3401028	3	NUT-JAM 3/8-16 ZP NYLOC	
24	712099PLT	2	BLT-SHOULDER 1/2 X 1/2 LG X 3/8-16	

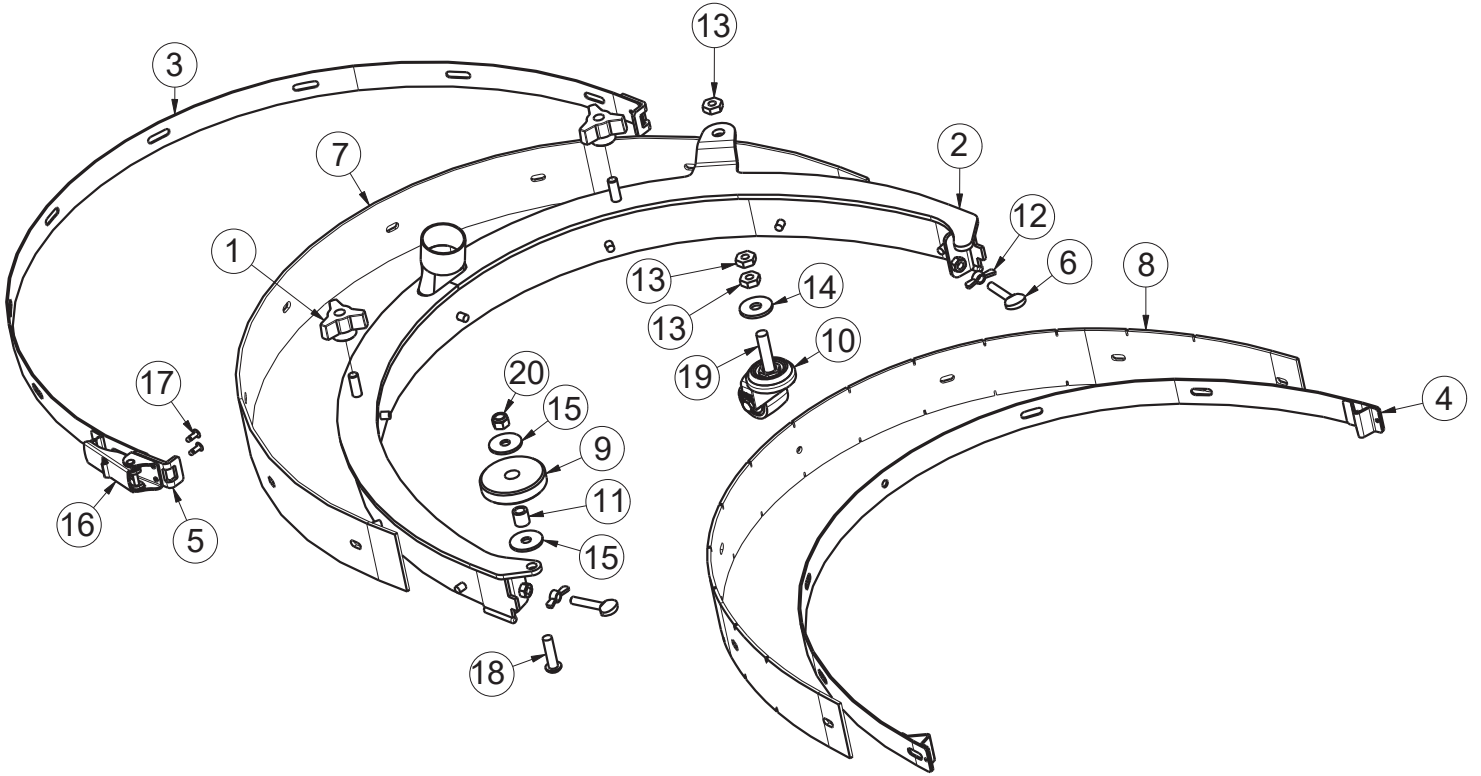

BILL OF MATERIAL - 245490			
ITEM	PART NO.	QTY	DESCRIPTION
1	210118	2	KNOB-3 SIDED 5/16 NYLOC
2	245315	1	WELDMENT, SQUEEGEE 20"
3	245324	1	WELDMENT, OUTER BAND 20
4	245328	1	WELDMENT, INNER STRAP 20
5	245331	1	MOUNT, LATCH
6	245332	2	SCR-THUMB 1/4-20 x 1.25 SS
7	245333-1	1	SQUEEGEE BLADE, 20" OUTER, PRIMOTHANE
8	245334-1	1	SQUEEGEE BLADE, 20" INNER, PRIMOTHANE
9	245339	1	ROLLER- SQUEEGEE
10	245563	1	CASTER
11	600114	1	SPACER, .328 B .498 OD .500 ,SS
12	711389	2	NUT-WING 1/4-20 ZP
13	711391	3	NUT-JAM 3/8-16 ZP
14	711855	1	WASHER-FENDER 3/8 X 1.12 X .10 ZP HARD
15	730526	2	WASHER-FENDER M8 X 24 SS
16	730652	1	LATCH, UNDER CENTER
17	731293	2	RIVET-BLIND 5/32 .187 GRIP SS
18	770536	1	SCR-BHSCS M8-1.25 X 30 SS
19	3401572	1	SCR-BHSCS 3/8-16 X 1.75 ZP
20	12040259	1	NUT-NYLOC M8 X 1.25 SS

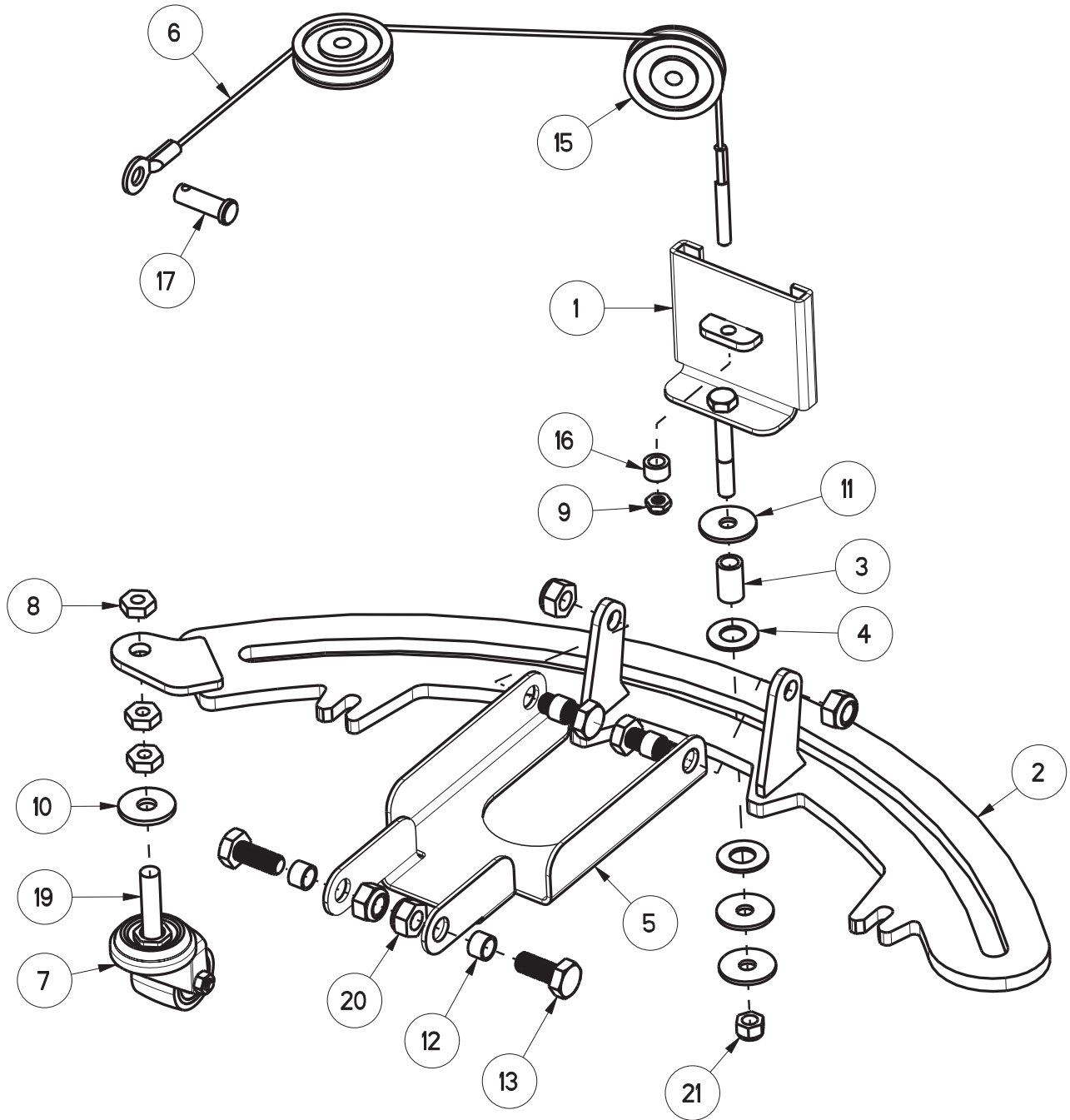

BILL OF MATERIAL - 245489			
ITEM	PART NO.	QTY	DESCRIPTION
1	245301	1	WELDMENT, SLIDER
2	245305	1	WELDMENT, SQUEEGEE MOUNT 20"
3	245309	1	SPACER, NYLON, .344 B .500 OD .813 T
4	245310	2	WASHER, NYLON, .510 B 1.00 OD .062 T
5	245311	1	LINK, SQUEEGEE PIVOT 20"
6	245313	1	CABLE-SQUEEGEE MR20"
7	245563	1	CASTER
8	711391	3	NUT-JAM 3/8-16 ZP
9	711688	1	NUT-JAM 1/4-20 NYLOC SS
10	711855	1	WASHER-FENDER 3/8 X 1.12 X .10 ZP HARD
11	730526	3	WASHER-FENDER M8 X 24 SS
12	730873	4	SPACER, .406 B .498 OD .325 T
13	730958	4	SCR-HH M10-1.50 X 25 SS FULL THREAD
14	881002	6	PIN-CLEVIS 5/16 X 1.00 ZINC (NOT SHOWN)
15	3300368	2	PULLEY-PLASTIC 2" x .25" GROOVE
16	3335273	1	SPACER-.32 OD X .499 OD X .31 LG
17	3400117	1	PIN-CLEVIS 3/8 x 1.125 ZP
18	3400125	7	RING-RUE 3/8 (NOT SHOWN)
19	3401572	1	SCR-BHSCS 3/8-16 X 1.75 ZP
20	12040069	4	NUT-NYLOC M10 X 1.5 ZD CLASS 6
21	12040259	1	NUT-NYLOC M8 X 1.25 SS

Wiring Diagrams

1

PAGE LAYOUT

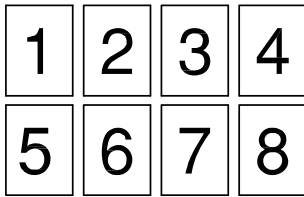

PAGES GO TOGETHER AS SHOWN TO SEE THE ENTIRE SCHEMATIC AS ONE.

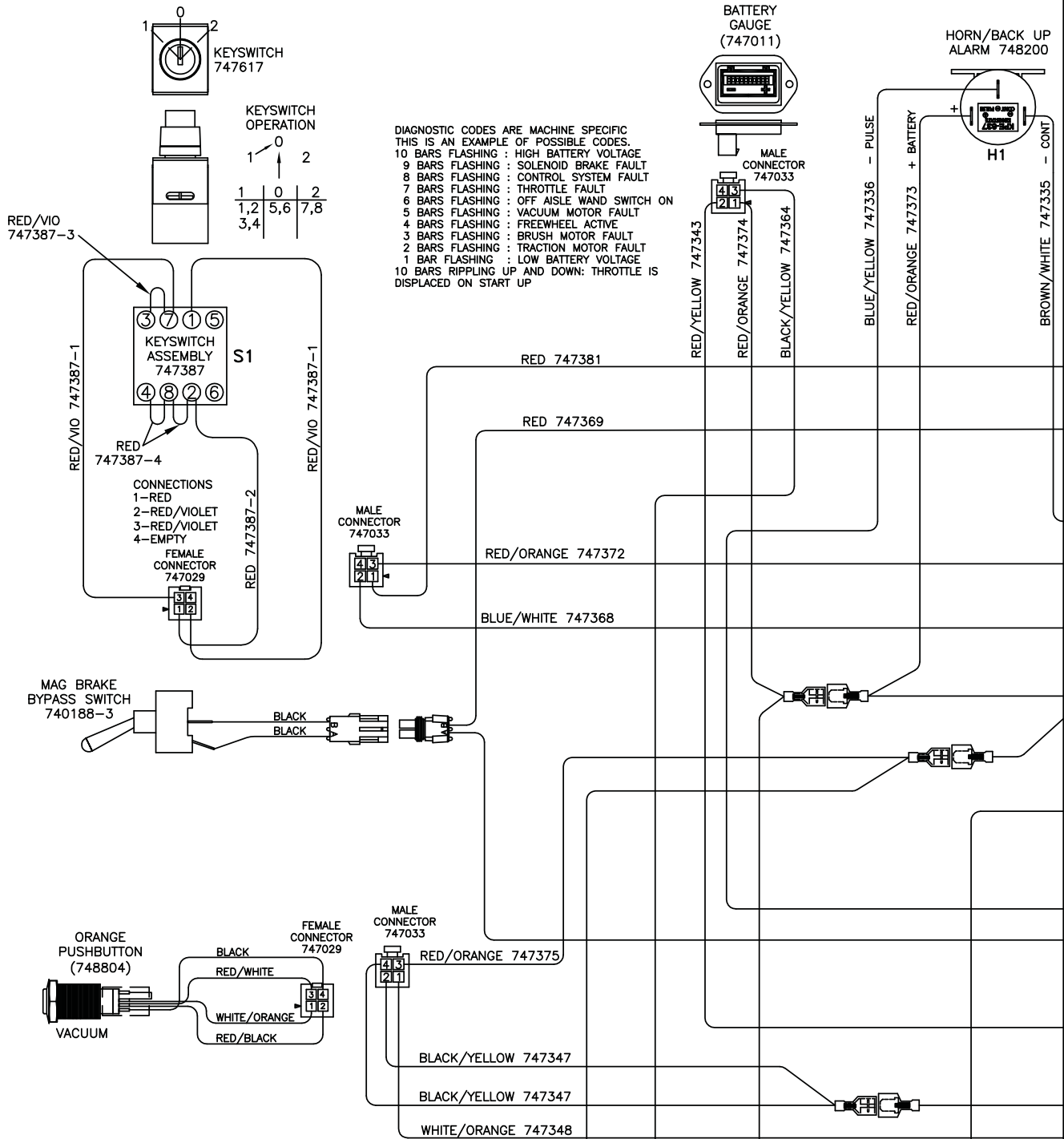

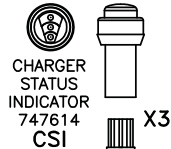
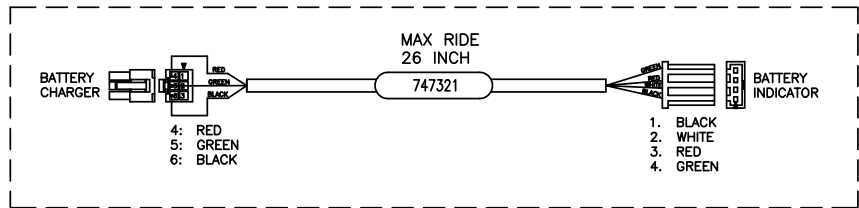

120VAC 60Hz
or
230VAC 50Hz
(different plug)
CORD
748680CE
748680 (UK)

CHARGER
957760
IEC60320 C14

MAX RIDE 26
BATTERY CHARGER
100-240V~ 50/60Hz
957764 (115VAC)
NEMA 5/15P
957760 (230VAC)
IEC 60320 C14

BATTERY CHARGER
100-240V~ 50/60Hz
957761 (115VAC)
NEMA 5/15P
957760 (230VAC)
IEC 60320 C14

ROTARY SWITCH

CHARGING PROFILES

1. 956712 12V 105Ah-FLOODED(-1)
2. 956140 12V 140Ah-FLOODED(-2)
3. 956135 12V 135Ah-GEL(G-3)
4. 956100 12V 100Ah-GEL(G-4)

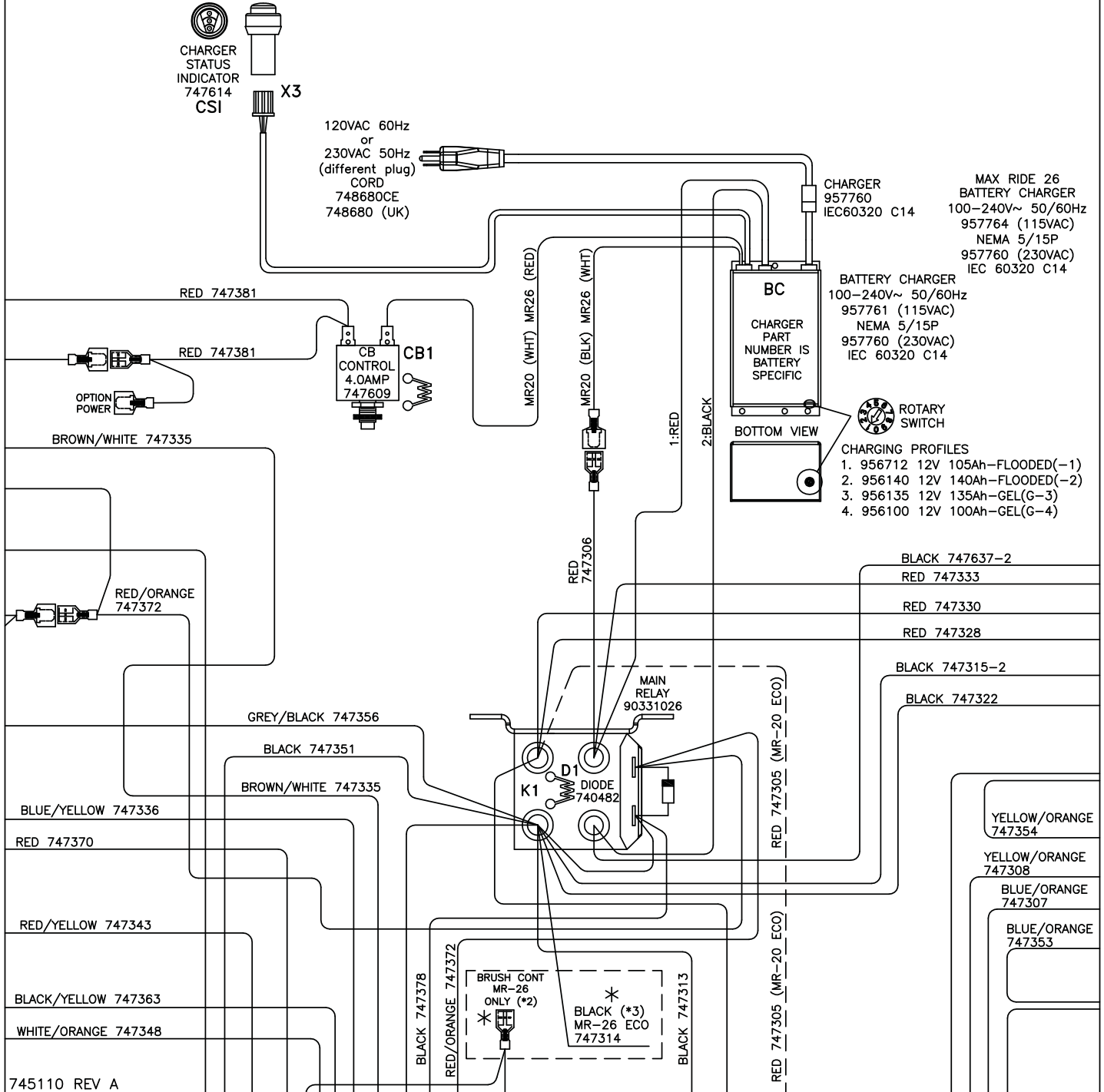



RELAY NUT COVER
 MAIN RELAY M8 15592033 (4)
 VACUUM RELY M6 15592025 (2)
 BRUSH MOTOR RELAY M6 15592025 (4)

*RELAY TERMINALS ARE METRIC
 MAIN RELAY: M8 TORQUE TO 8-9.5Nm
 VACUUM & BRUSH RELAY:M6 TORQUE TO 3.6-3.9Nm

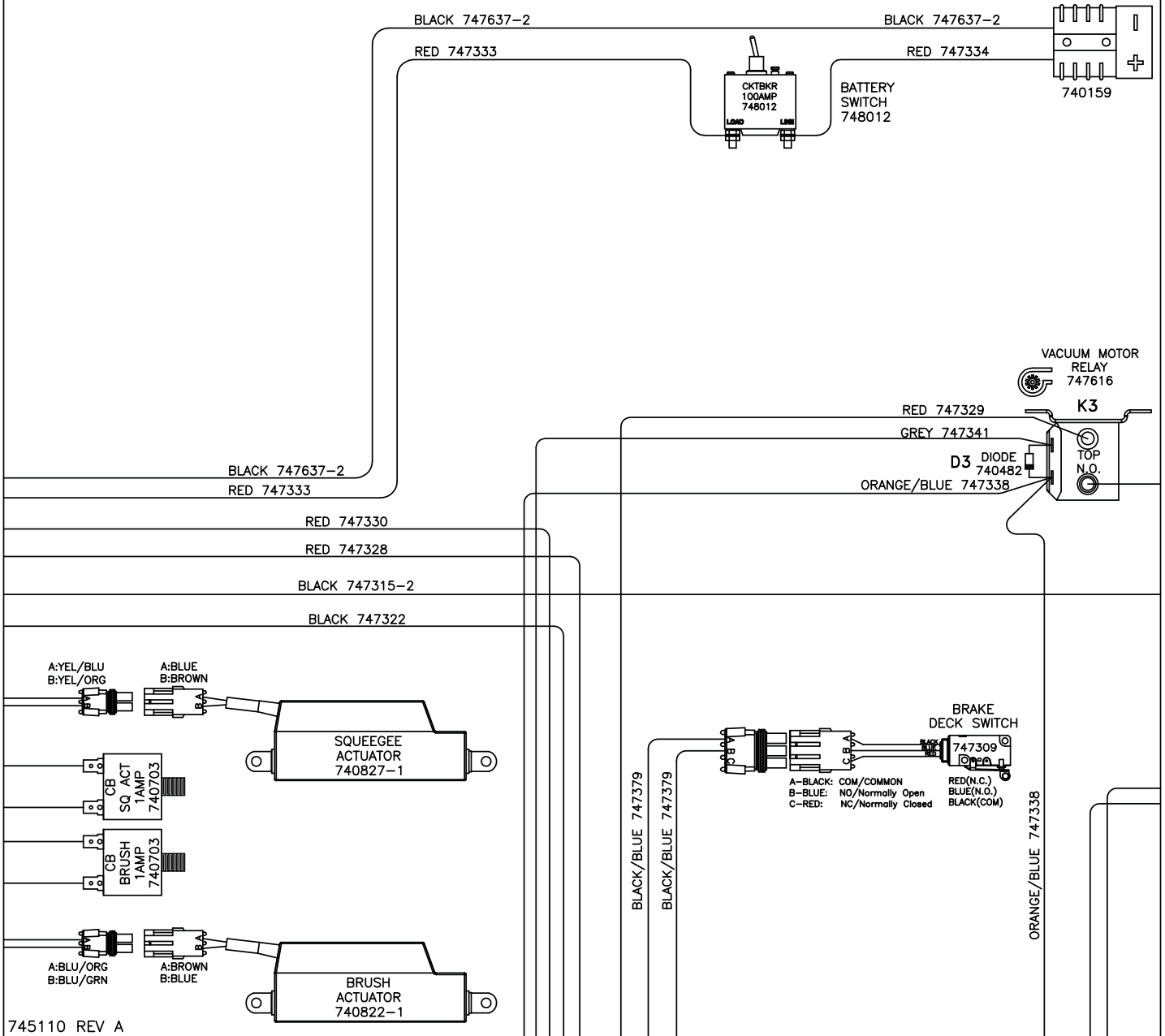

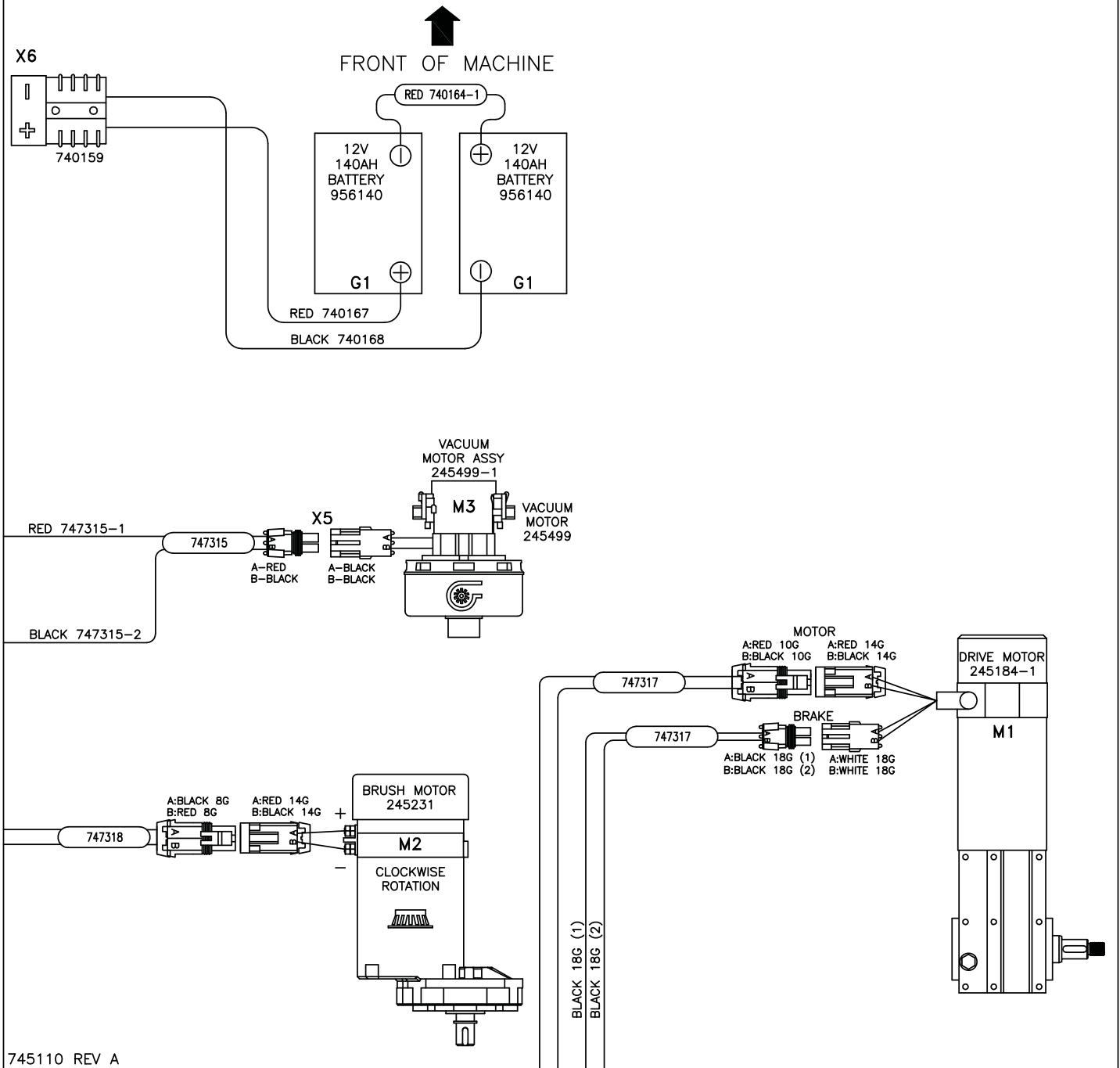

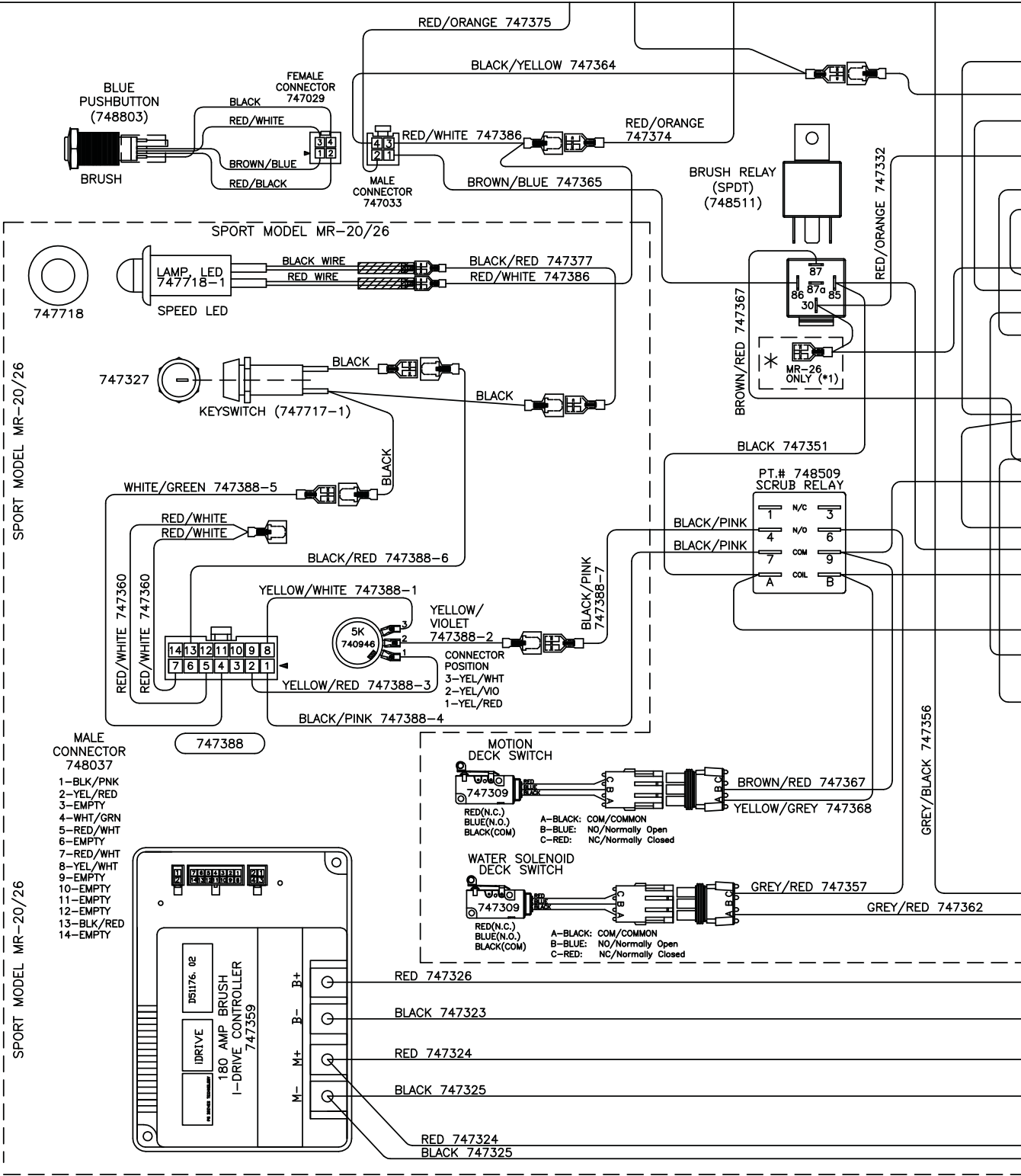

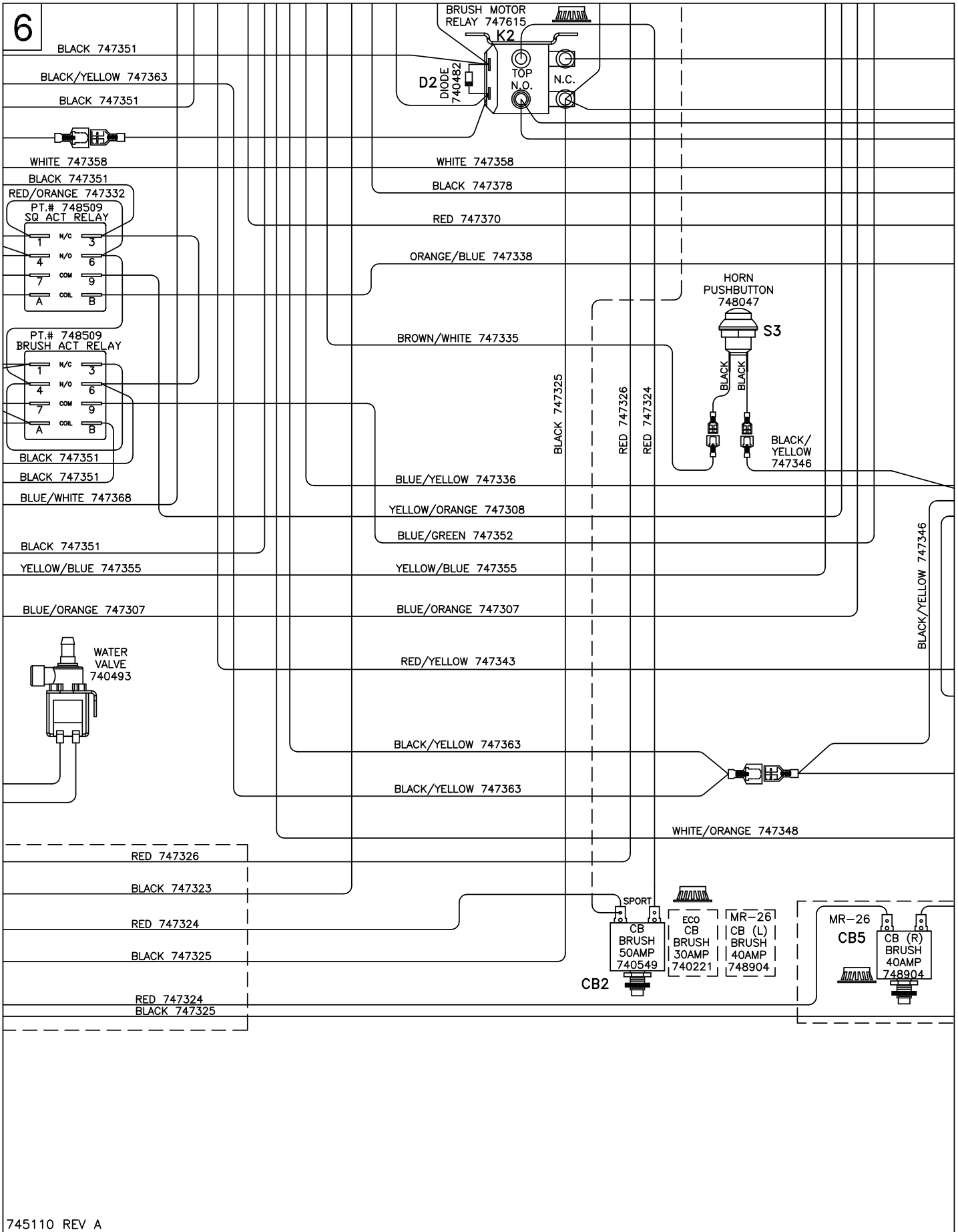

7

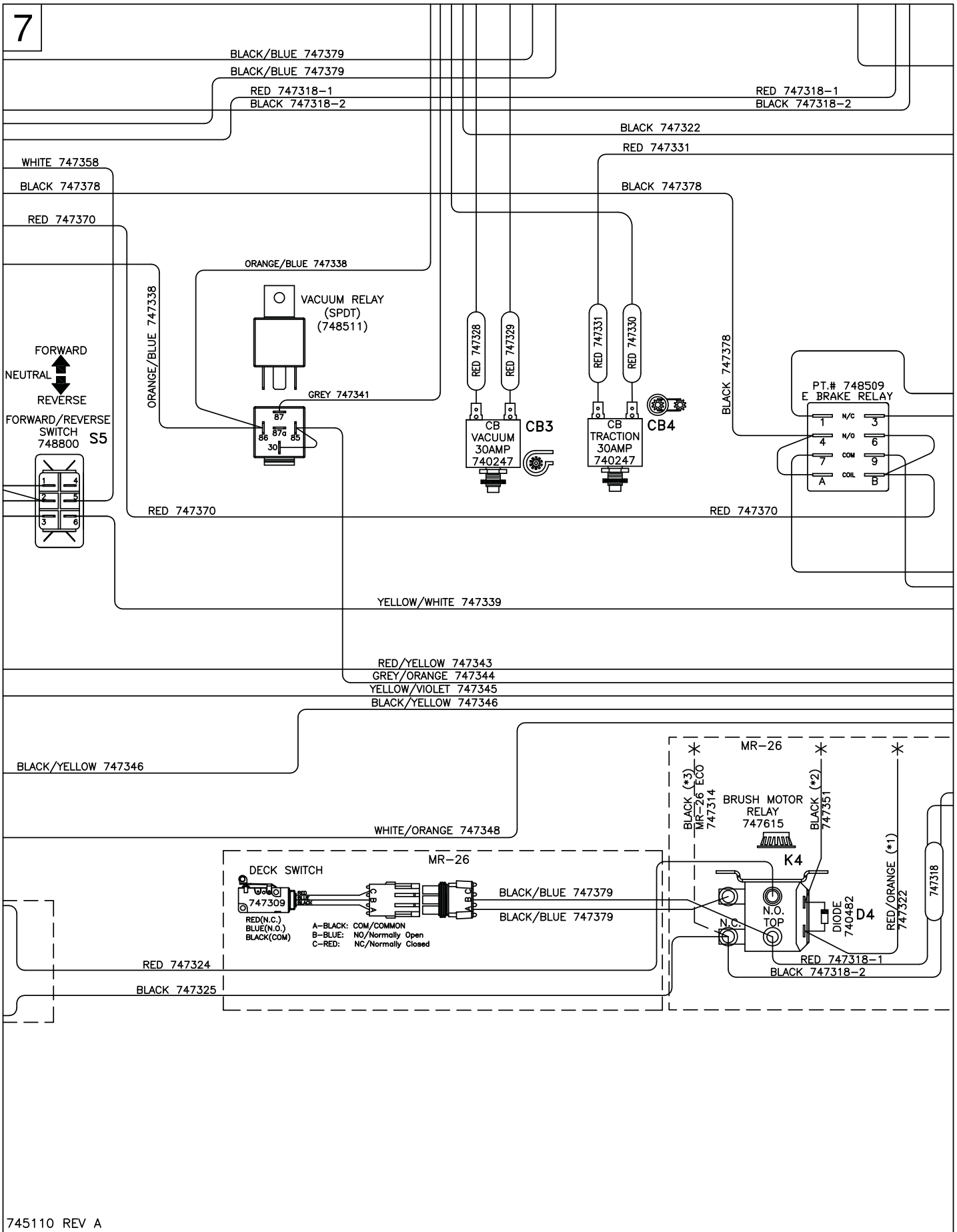

745110 REV A

Minuteman International Made Simple Commercial Limited Warranty

REVISION O EFFECTIVE 4/1/2016

Minuteman International, Inc. warrants to the original purchaser/user that the product is free from defects in workmanship and materials under normal use. Minuteman will, at its option, repair or replace without charge, parts that fail under normal use and service when operated and maintained in accordance with the applicable operation and instruction manuals. All warranty claims must be submitted through and approved by factory authorized repair stations.

This warranty does not apply to normal wear, or to items whose life is dependent on their use and care, such as belts, cords, switches, hoses, rubber parts, electrical motor components or adjustments. Parts manufactured by Minuteman are covered by and subject to the warranties and/or guarantees of their manufacturers. Please contact Minuteman for procedures in warranty claims against these manufacturers.

Special warning to purchaser -- Use of replacement filters and/or pre-filters not manufactured by Minuteman or its designated licensees, will void all warranties expressed or implied. A potential health hazard exists without original equipment replacement.

All warranted items become the sole property of Minuteman or its original manufacturer, whichever the case may be.

Minuteman disclaims any implied warranty, including the warranty of merchantability and the warranty of fitness for a particular purpose. Minuteman assumes no responsibility for any special, incidental or consequential damages.

This limited warranty is applicable only in the U.S.A. and Canada, and is extended only to the original user/purchaser of this product. Customers outside the U.S.A. and Canada should contact their local distributor for export warranty policies. Minuteman is not responsible for costs or repairs performed by persons other than those specifically authorized by Minuteman. This warranty does not apply to damage from transportation, alterations by unauthorized persons, misuse or abuse of the equipment, use of non-compatible chemicals, or damage to property, or loss of income due to malfunctions of the product.

If a difficulty develops with this machine, you should contact the dealer from whom it was purchased.

This warranty gives you specific legal rights, and you may have other rights which vary from state to state. Some states do not allow the exclusion or limitation of special, incidental or consequential damages, or limitations on how long an implied warranty lasts, so the above exclusions and limitations may not apply to you.

Model	Parts	Labor	Poly	Travel**
Cord Electric Group	5yrs	3yrs	12yrs	90 days
Battery Operated Group	5yrs	3yrs	12yrs	90 days

Exceptions.....

Model	Parts	Labor	Poly	Travel**
Port A Scrub, all models	1yr	6months	12yrs	90 days
A3S Blower	1yr	1yr	0	0
Phenom Dual Motor Upright Vacuums	2yrs	2yrs	0	0
Explosion Proof Vacuum	1yr	1yr	0	0
Propane Burnisher	1yr	1yr	0	90 days
**Travel, 2 hours max				

<i>Stand-alone Battery Chargers:</i>	One year
<i>Replacement Parts:</i>	Ninety days
<i>Batteries:</i>	0-3 months full replacement, 4-12 months pro-rate
<i>Polypropylene Plastic Tanks:</i>	12yr warranty, no additional labor

“Excellence Meets Clean”

**Minuteman is a Full Line Manufacturer of Sweepers and Scrubbers,
for Industrial Facilities.**

14N845 U.S. Route 20, Pingree Grove, IL 60140 USA
Phone (800) 323-9420 - www.minutemanintl.com
A Member of the Hako Group