



www.usviper.com

AUTO SCRUBBERS

# OWNERS MANUAL

IMPORTANT: READ OWNERS MANUAL CAREFULLY  
Please fill out & return your warranty card !

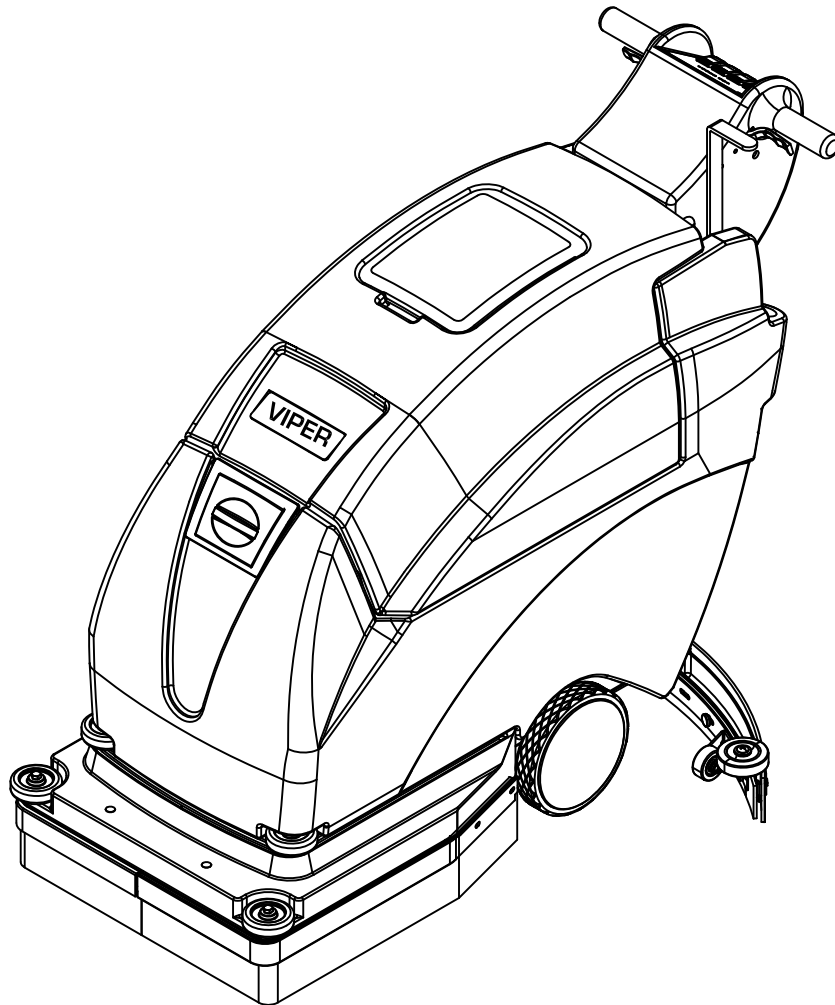

MODEL #

FANG 20 & 20T

SERIAL #

VIPER NORTH AMERICA  
[866] 418-4737  
[866] 41-VIPER

VIPER...exceptional  
value

REV.06(2014-10-31)

VF82089



TABLE OF CONTENTS
-------------------

SAFETY PRECAUTIONS	3
MACHINE COMPONENTS	4
MACHINE SET UP	5
MACHINE INSTALLATION	5-6
MACHINE OPERATION	6
TANK DRAINING	7
BATTERY CHARGING	7-8
PREVENTATIVE MAINTENANCE	8-9
MACHINE STORAGE	9
BASIC TROUBLESHOOTING	10
PARTS BREAKDOWNS AND LISTS	11-31
WIRING DIAGRAM	32-33



## SAFETY PRECAUTIONS

This machine is intended for commercial use. It is constructed for use in an indoor environment and is not intended for any other use. Use only with recommended accessories.

All operators shall read, understand and exercise the following safety precautions:

### 1) DO NOT OPERATE MACHINE:

- Unless trained and authorized.
- Unless you have read and understand the operators manual.
- In flammable or explosive areas.
- If not in proper operating condition.
- In outdoor areas.

### 2) BEFORE OPERATING MACHINE:

- Make sure all safety devices are in place and operate properly.

### 3) WHEN USING MACHINE:

- Go slow on inclines and slippery surfaces.
- Follow all safety guidelines.
- Be very careful when using the machine in reverse.
- Report and fix any damage to machine prior to operating it.

### 4) BEFORE LEAVING OR SERVICING MACHINE:

- Stop machine on level ground.
- Turn machine off.

### 5) WHEN SERVICING MACHINE:

- Read operators manual thoroughly prior to operating or servicing this machine.
- Use manufacturer supplied or approved replacement parts.
- Secure machine with wheel blocks prior to jacking the machine up.
- Use approved jack or hoist to safely elevate the machine.

### WHEN SERVICING MACHINE: (con't)

- Disconnect batteries prior to working on machine.
- Wear gloves when handling batteries or battery cables.
- Avoid any contact with battery acid.
- Avoid moving parts. Do not wear loose fitting clothing while servicing machine.

#### **WARNING**

: Batteries emit hydrogen gas. Explosion or fire can result from hydrogen gas. Keep sparks and open flames away! Keep battery compartment open when charging.

#### **WARNING**

: Flammable materials can cause an explosion or fire. Do not use flammable materials in tanks.

#### **WARNING**

: Flammable materials or reactive metals can cause explosion or fire. Do not pick up.

# MACHINE COMPONENTS

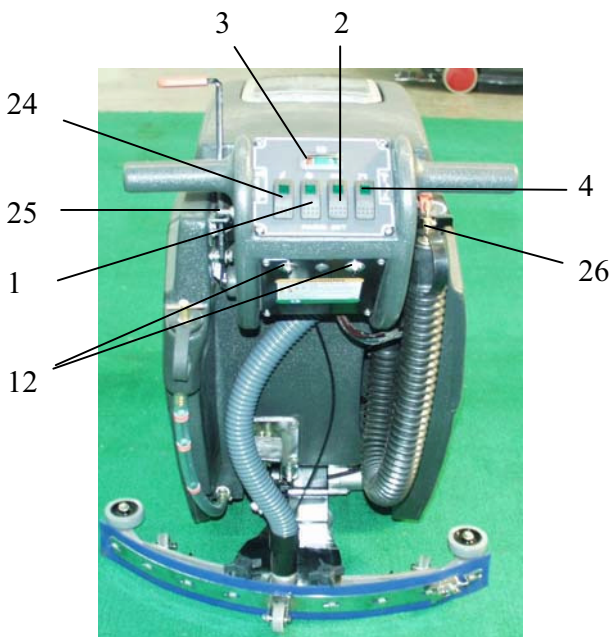
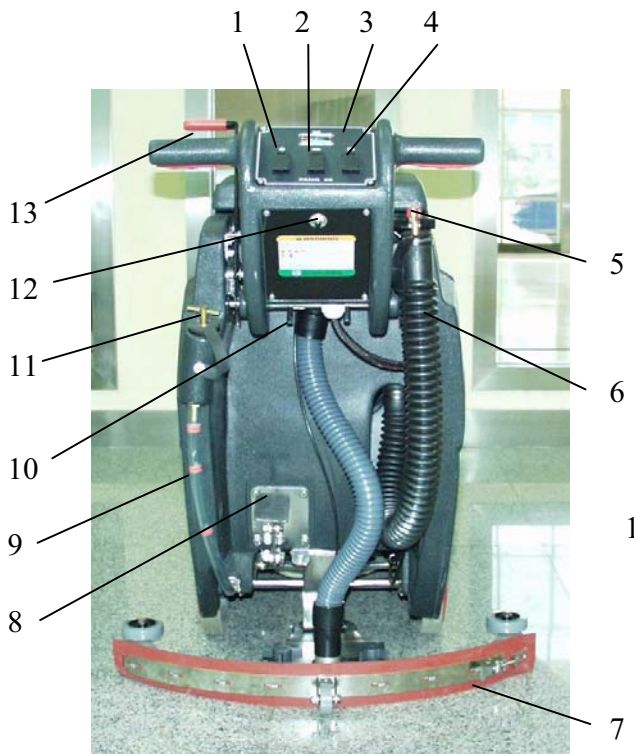

1. Vacuum ON/OFF switch
2. Brush ON/OFF switch
3. Battery level meter
4. Solution ON/OFF switch
5. Solution control knob
6. Recovery tank drain hose

7. Squeegee assembly
8. Brush lift foot pedal
9. Solution tank level sight tube
10. Console adjustment levers
11. Rear solution fill
12. Circuit breakers
13. Squeegee lift lever
14. Control housing
15. Solution tank
16. Transport wheels
17. Scrub head
18. Scrub head skirt
19. Protective rollers
20. Front solution fill
21. Recovery tank
22. Recovery tank lid
23. Operating triggers
24. Main power ON/OFF switch
25. Reverse switch
26. Speed control knob

## MACHINE SET UP & INSTALLATION

### UNCRATING MACHINE

Be sure and check packing carton for any damage. Immediately report any damage to carrier. Check contents of package to ensure that the following items are included: Machine, batteries (x2), squeegee assembly, battery charger, and pad driver.

### BATTERY CONNECTIONS

The batteries are already in the machine upon delivery; however, you will need to connect the cables to the battery posts.

#### **WARNING**

: Batteries emit hydrogen gas.

Explosion or fire can result from hydrogen gas. Keep sparks and open flames away! Keep battery compartment open when charging.

1. Be sure power switch is in the "off" position.
2. Open recovery tank to gain access to battery compartment.
3. Carefully place the two batteries into the compartment as shown in figure below. Place the battery brace at the rear of the two batteries.

#### **DO NOT DROP BATTERIES INTO COMPARTMENT!**

4. Connect battery cables to posts in numbered order as shown in drawing below. (RED to POSITIVE and BLACK to NEGATIVE)

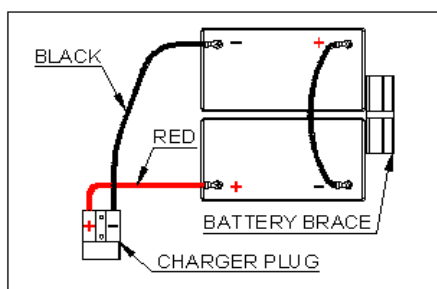

5. Apply a coat or protective spray on the cable connections to prevent battery corrosion.

## MACHINE SET UP

### PRE-OPERATION CHECKS

1. Sweep or dust mop the surface to be cleaned.
2. Check battery meter to make sure batteries are fully charged. (see BATTERY CHARGING)
3. Check that squeegee is properly installed.
4. Check that brush / pad is properly installed.

### INSTALLING PAD DRIVER OR BRUSH

1. Ensure that the machine is turned off
2. Lower brush head assembly to the floor by stepping on the foot pedal and pushing pedal forward.
3. Tilt the machine backward to access the drive motor hub.

#### **HINT**

: Remove the squeegee assembly prior to tilting the machine backwards. It makes the process faster and easier.

#### **WARNING**

: Do not keep the machine tilted back for a long time. This could cause battery acid to leak from the batteries.

4. If using a pad driver, first attach the appropriate pad to the pad driver surface.
5. Mount the pad driver or brush to the drive motor hub by lining up the three studs with the three holes in the drive motor hub. Once in the holes, rotate the driver toward the spring clip to lock driver into place.

### MOUNTING THE SQUEEGEE

1. Pull back on the squeegee lift lever to raise the squeegee bracket up.
2. Loosen the two knobs on the squeegee and slide the squeegee into the slots at the rear of the squeegee bracket. (the wheels on the squeegee point to the back)
3. Tighten the knobs securely.



## **FILLING THE SOLUTION TANK**

1. The Fang 20 / 20T can be filled in two different locations:
  - a. Front fill area for use with a hose or a bucket.
  - b. Rear fill area for use with a hose only.
2. Determine which fill area you would like to use to fill the machine with water.
3. Fill solution tank with up to 13 gallons of water. (water temperature should not exceed 140° F) The clear tube in the back left of the machine has gallon markers to help determine the water level in the solution tank

### **HINT**

: If you are filling the solution tank with a bucket, make sure the bucket is clean. This will prevent debris from clogging the lines or solenoid.

### **WARNING**

: Do not put any flammable materials into solution tank. This can cause an explosion or a fire. Only use recommended cleaning chemicals. Contact your janitorial supply distributor for recommendations on proper chemicals.

## **MACHINE OPERATION**

### **WARNING**

: Do not operate machine unless you have read and understand this manual.

1. Set control housing to a comfortable operating height by squeezing together the two thumb levers directly underneath the housing. (see machine components, item #10)
2. Lower squeegee assembly to the floor by releasing the lift lever from its locked position. (see machine components, item #13)
3. Lower brush head assembly to the floor by stepping on the foot pedal and pushing pedal forward. (see machine components, item #8)
4. Turn main power to “on” position.(see machine components,item#24)
5. Turn brush motor to “on” position. (see machine components, item #2)
6. Turn vacuum motor switch to “on” position. (see machine components, item #1)
7. Turn the solution switch to “on” position. (see machine components, item #4)

- a. Solution will not begin to flow until the operating triggers are pulled.
8. The Fang 20T is self-propelled.The speed can be controlled by a dial located on the right side of the control housing.(see machine components,item #26)
  9. The Fang 20T has reverse.In order to activate reverse,there is a toggle switch located on the left side of the control housing.(see machine components,item #25)
  10. To begin scrubbing, pull on one or both of the red operating triggers. (see machine components, item #23) When these triggers are pulled, the brush will begin to spin and the solution will begin to flow.The Fang 20T will propel itself.
  11. The Fang 20 Begin scrubbing by moving the machine forward.

### **HINT**

: Do not keep the machine in the same position with the pad / brush spinning, or you could cause damage to the floor.

12. Adjust amount of solution flow by turning the solution control knob. Turn to the right for more solution, or turn left for less solution. (see machine components, item #5)

## **WHILE OPERATING MACHINE**

1. Occasionally look through the clear recovery tank lid to see if there is any foam build-up. If excessive foam is found, add defoamer to the recovery tank.

### **WARNING**

: Foam must not enter the float shut-off screen, or damage can occur to the vacuum motor. Foam will not activate the machines float shut-off device.

2. Occasionally view the clear tube at the back left of the machine to check the amount of cleaning solution that is left in the machine.
3. Occasionally check the battery level meter. (see machine components, item #3) When meter is in the red, recharge the batteries.

### **WARNING**

: When battery meter is in the red, do not continue to operate the machine. Battery damage may result.



- If the squeegee assembly leaves streaks on the floor, raise the squeegee off the floor and wipe the blades down with a damp cloth.

**WARNING**

: Do not use your fingers to wipe or remove debris from the blades, as injury may occur.

- When the solution tank runs empty, turn off the brush switch, solution switch and raise the brush head. Keep the squeegee down and continue to vacuum until all the dirty water is picked up. (see TANK DRAINING section to learn how to drain recovery and solution tanks)

**HINT**

: The brush motor is circuit breaker protected to protect it from damage. If this breaker trips, it can't be reset immediately. You must first determine what caused the breaker to trip, and allow the motor to cool down before you can reset the breaker. The breaker is located on the back panel of the control housing.

**TANK DRAINING**

- Turn the power off on the machine
- With the squeegee and brush head in their "up" position, transport machine to approved area for draining tank(s).

**DRAINING THE RECOVERY (DIRTY) TANK**

**HINT**

: Any time scrubbing is completed, or when refilling solution tank, the recovery tank should be drained and cleaned.

**WARNING**

: If the recovery tank is not drained when the solution tank has been refilled, foam or water may enter the float shut-off mechanism and cause damage to the vacuum motor.

- Remove the drain hose from the holder, and place the drain hose over the floor drain. Twist off the drain hose plug to begin the draining process. In order to completely empty the recovery tank, hinge opens the recovery tank and let it rest on the support stand.
- Clean the recovery tank after every use. Use a fresh water hose to rinse out the recovery tank.

Be careful not to spray water into the float shut-off mechanism.

**HINT**

: If you are storing the machine for any period of time, always leave the clear recovery tank lid off the tank so the tank can dry completely and smell fresh.

- Replace the drain hose plug tightly as soon as you are done draining the tank.

**DRAINING THE SOLUTION (CLEAN) TANK**

**HINT**

: Any time scrubbing operation is completed, the solution tank should be drained and cleaned.

- Pull down on the clear tube (back left of the machine) to remove it from the hose barb. This will allow the solution to flow freely into a bucket or floor drain.
- Rinse the solution tank with clean water after every use. This will help prevent chemical buildup and clogging of the solution lines.
- With clean water in solution tank, turn machine power on, solution switch "on" and pull the operating triggers. This will allow the clean water to flush through and clean the solution plumbing.
- Once tank is rinsed, flushed and drained, reconnect the clear tube to the hose barb. Be sure the tube is pushed all the way up on the hose barb.

**BATTERY CHARGING**

**WARNING**

: Use only approved chargers with the following specifications:

- Automatic shut off circuit
- Deep cycle charging
- Output current of 10 – 20 amps
- Output voltage of 24 volts

**HINT**

: For the best machine performance, keep batteries charged at all times. Do not let them sit in a discharged condition.

**WARNING**

: Batteries are dangerous! Batteries emit hydrogen gas and an explosion or fire can result. Keep sparks and fire away from batteries at all times. When charging the machine, make sure the battery compartment is left open.

1. Place charger and machine in a well ventilated area.
2. Turn machine off.
3. Open recovery tank up, exposing battery compartment
4. Check fluid level in each battery cell. Do not charge batteries unless fluid is slightly covering the battery plates. Do not overfill the batteries. Overfilling may cause the batteries to overflow during charging due to expansion. Replace the caps prior to charging.
5. Plug approved charger into grounded wall outlet before plugging the charger into the machine.
6. Plug charger into red charger receptacle located in the front left of the battery compartment.

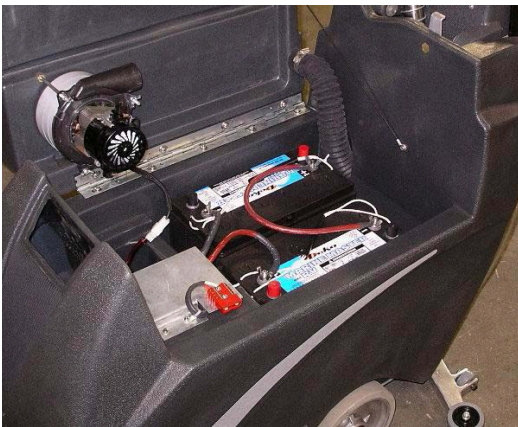

7. Flip up the recovery tank “kick stand” and gently lay the recovery tank down until it rests on the stand.
8. The charger will automatically begin to charge the batteries, and it will automatically shut down once the batteries are fully charged.
9. Upon completion of charging, first unplug the charger from the wall outlet, and then disconnect the charger from the machine.
10. Check the battery level after charging is complete. If fluid level is low, add distilled water to bring the fluid level up to the bottom of the sight tubes. Replace the caps and wipe the batteries down with a towel.

**PREVENTATIVE MAINTENANCE**

**WARNING** : Before performing any maintenance on the machine, be sure that the power is turned off, or the batteries are disconnected!

**WARNING** : Repairs are to be completed by Authorized Service Centers only. Any repairs completed by unauthorized persons will void the warranty.

**DAILY MAINTENANCE**

1. Remove pad driver / brush and clean with approved cleaner.
2. Drain recovery and solution tanks completely and rinse out with clean water. Visually check the recovery tank for debris and clean out as necessary.
3. Raise squeegee assembly off floor and wipe it down with a damp towel. Be sure to store the squeegee in the up position.
4. Remove the float shut-off assembly and rinse it out with clean water.



5. Clean machine with an approved cleaner and a damp towel.
6. Recharge batteries.

**WEEKLY MAINTENANCE**

1. Check fluid level in batteries.
2. Check batteries for loose or corroded cables.
3. Keep battery tops clean from corrosion.

**MONTHLY MAINTENANCE**

1. Check machine for leaks and loose fasteners.
2. Lubricate all grease points and pivot points with silicon spray and approved grease.
3. Place machine over a floor drain. Flush solution system by pouring 3 gallons of hot



water and approved alkaline detergent into the solution tank and running machine (with solution control on) for 45 seconds. Turn machine off and let it sit overnight. Then next day, drain the remaining solution and rinse the solution tank out with clean water.

### **VACUUM MOTOR MAINTENANCE**

1. Contact your local Viper Distributor for any motor maintenance.
2. Vacuum motor should have the brushes checked every 250 hours. Brushes should be replaced when they are worn to a length of 10mm or less.

### **BATTERY MAINTENANCE**

#### **HINT**

: For the best machine performance, keep batteries charged at all times. Do not let them sit in a discharged condition.

#### **WARNING**

: Batteries are dangerous! Batteries emit hydrogen gas and an explosion or fire can result. Keep sparks and fire away from batteries at all times.

#### **WARNING**

: Whenever servicing batteries, be sure to wear protective gloves. Avoid contact with battery acid at all times!

1. Always follow the battery charging directions as outlined in the BATTERY CHARGING section of this manual.
2. Keep battery tops and terminals free from corrosion. A strong solution of baking soda and water is the best way to keep the batteries corrosion free. **DO NOT ALLOW THE BAKING SODA / WATER SOLUTION TO ENTER THE BATTERY CELLS.**
3. Use a wire brush with the baking soda solution to properly clean the battery posts and connections.
4. Check battery connections for wear and loose terminals. Replace if necessary.

### **MACHINE STORAGE**

1. Always store the machine indoors.

2. Always store the machine in a dry area.
3. Always store the machine in its upright position.
4. Always store the machine with the pad driver / brush raised off the floor.
5. Always store the machine with the squeegee assembly raised off the floor.
6. If storing in an area which may reach freezing temperatures, be sure to drain all fluids from the machine prior to storage. Any damage caused by freezing temperatures will not be covered by the warranty.
7. Drain the recovery tank and remove the clear on the top of the recovery tank so that it can “breathe” during storage.
8. Drain the solution tank of all fluid.

## **BASIC TROUBLESHOOTING**

<b>PROBLEM</b>	<b>CAUSE</b>	<b>SOLUTION</b>
No power	Bad batteries	Replace batteries
	Batteries need to be charged	Charge batteries (see Battery Charging)
	Loose battery cable	Tighten loose cable(s)
	Batteries not connected properly	Follow battery installation instructions
Brush motor does not run	Bad brush switch	Contact Viper Distributor
	Brush circuit breaker has tripped	Check brush motor for obstructions and reset breaker
	Rectifier has burned out	Contact Viper Distributor
	Bad wiring	Contact Viper Distributor
	Bad brush motor	Contact Viper Distributor
	Carbon brushes worn out	Contact Viper Distributor
Vacuum motor does not run	Bad solenoid	Contact Viper Distributor
	Bad vacuum switch	Contact Viper Distributor
	Bad wiring	Contact Viper Distributor
	Bad vacuum motor	Contact Viper Distributor
Short run time	Carbon brushes worn out	Contact Viper Distributor
	Batteries need to be charged	Charge batteries (see Battery Charging)
	Batteries need maintenance	See Battery Maintenance in this manual
	Bad cell in battery(s)	Replace batteries
Little or no solution flow	Bad charger	Replace charger
	Bad solution switch	Contact Viper Distributor
	Clogged solution solenoid	Contact Viper Distributor
	Clogged solution filter	Remove filter and clean
	Solution line obstructed	Remove solution line and clean
Poor water pick up	Solution flow adjustment knob in need of adjustment	Increase flow by twisting solution adjustment knob to the right. Decrease flow by twisting solution adjustment knob to the left.
	Squeegee clogged	Clean debris off squeegee with damp towel
	Squeegee blades worn	Install new squeegee blades
	Squeegee not mounted correctly	Confirm that the squeegee assembly is securely fastened to the machine and not loose fitting.
	Vacuum hoses have a hole or are loose	Check hose connections and make sure they are firm. Replace hose if damaged.
	Vacuum hose may be clogged	Check hose for debris and remove any clog.
	Drain hose stopper is loose	Tighten drain plug.
	Batteries need to be charged	Charge batteries (see Battery Charging)
	Vacuum motor is loose	Tighten vac motor mounting screws. Do not overtighten or damage will occur.
	Recovery tank lid is loose	Confirm the clear recovery tank lid is securely in place.
	Recovery tank inlet hole is clogged	Drain recovery tank and tilt tank on side. Check the inlet hole for debris and remove debris.
	Recovery tank is full	Drain recovery tank.
Float shut off is clogged	Remove float shut off from inside recovery tank and remove any debris.	

FANG 20 - CONTROL HOUSING

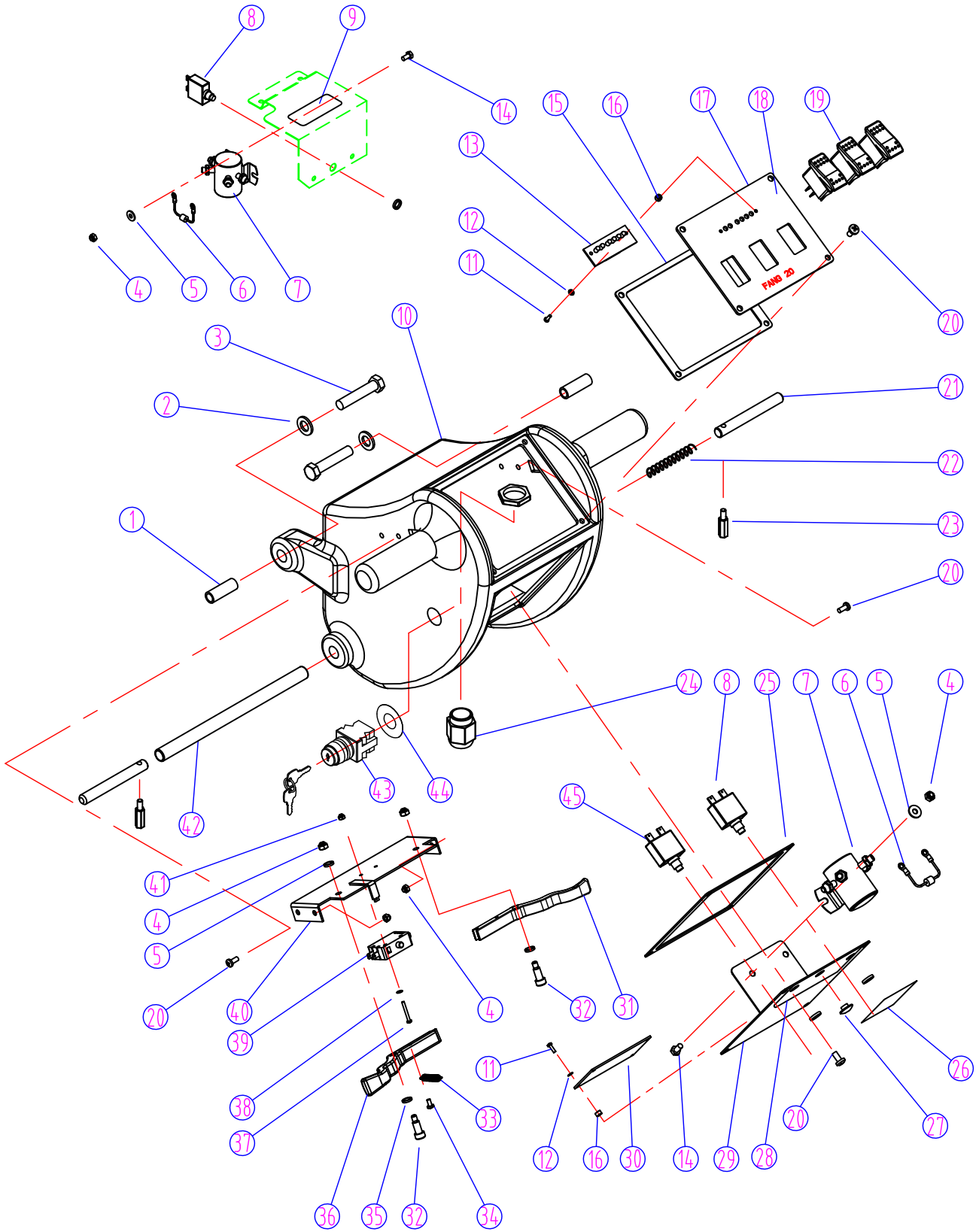

## FANG20 - CONTROL HOUSING

DIA NO	PART NUMBER	DESCRIPTION	NO REQ'D
1	VF81713	BUSHING	2
2	VF14122	WASHER,PLAIN,M10XM20X2	2
3	VF14121	SCREW,M10X65	2
4	VF13502	NUT,LOCK,M6	10
5	GT13032	WASHER,PLAIN,M6	2
6	VF81781	DIODE,400V	3
	VF81781-X	DIODE WITH ENDS	3
7	VF81726A	SOLENOID,24V	2
8	VF81734	BREAKER,CIRCUIT,35 AMP	2
9	VF83149	LABEL,CIRCUIT BREAKER	1
10	VF82108	HOUSING,CONTROL	1
11	VF14078	SCREW,M3X10	6
12	VA50477	WASHER,PLAIN,M3XM10X1	6
13	VF81718	LIGHTS,BATTERY CAPACITY	1
14	VF13495	SCREW,M6X16	4
15	VF82313	GASKET	1
16	VF81719	SPACER	6
17	VF82102A	PANEL,SWITCH	1
18	VF82103A	LABEL,SWITCH	1
19	VF81721	SWITCH,LIGHTED ROCKER	3
20	VF14200	SCREW,M6X16	12
21	VF81709	PIN,HANDLE LOCK	2
22	VF81716	SPRING	1
23	VF81710	PIN,HANDLE ADJUSTMENT	2
24	VF81744B	STRAIN RELIEF,CORD	1
25	VF82312	GASKET	1
26	VF82085	SERIAL TAG	1
27	GV40239	COVER	1
28	VF83148	LABEL,CIRCUIT BREAKER	1
29	VF82303A	PANEL,CONTROL HOUSING	1
30	VF81703	BATTERY CAPACITY,CONTROL BOARD	1
31	VF82107BD	HANDLE,RIGHT	1
32	VF81711	BOLT,SHOULDER M8XM15XM6	2
33	VF81712	SPRING	1
34	VF13491	SCREW,M4X12	1
35	VF13514A	WASHER,PLAIN,M8XM16.5X1	2
36	VF82106BD	HANDLE,LEFT	1
37	VF14212	SCREW,M3X25	2
38	VF13511	WASHER,TOOTH,M3	2
39	VF44203	SWITCH ASSEMBLY	1
40	VF81707	BRACKET,SWITCH	1
41	VV13652	NUT,LOCK,M3	2
42	VF81714	TUBE,HANDLE,ADJUSTMENT	1
43	VF82153	SWITCH,KEY	1
44	VF82160	LABEL,KEY SWITCH	1
45	VF99012	BREAKER,CIRCUIT,12 AMP	1

FANG 20T - CONTROL HOUSING

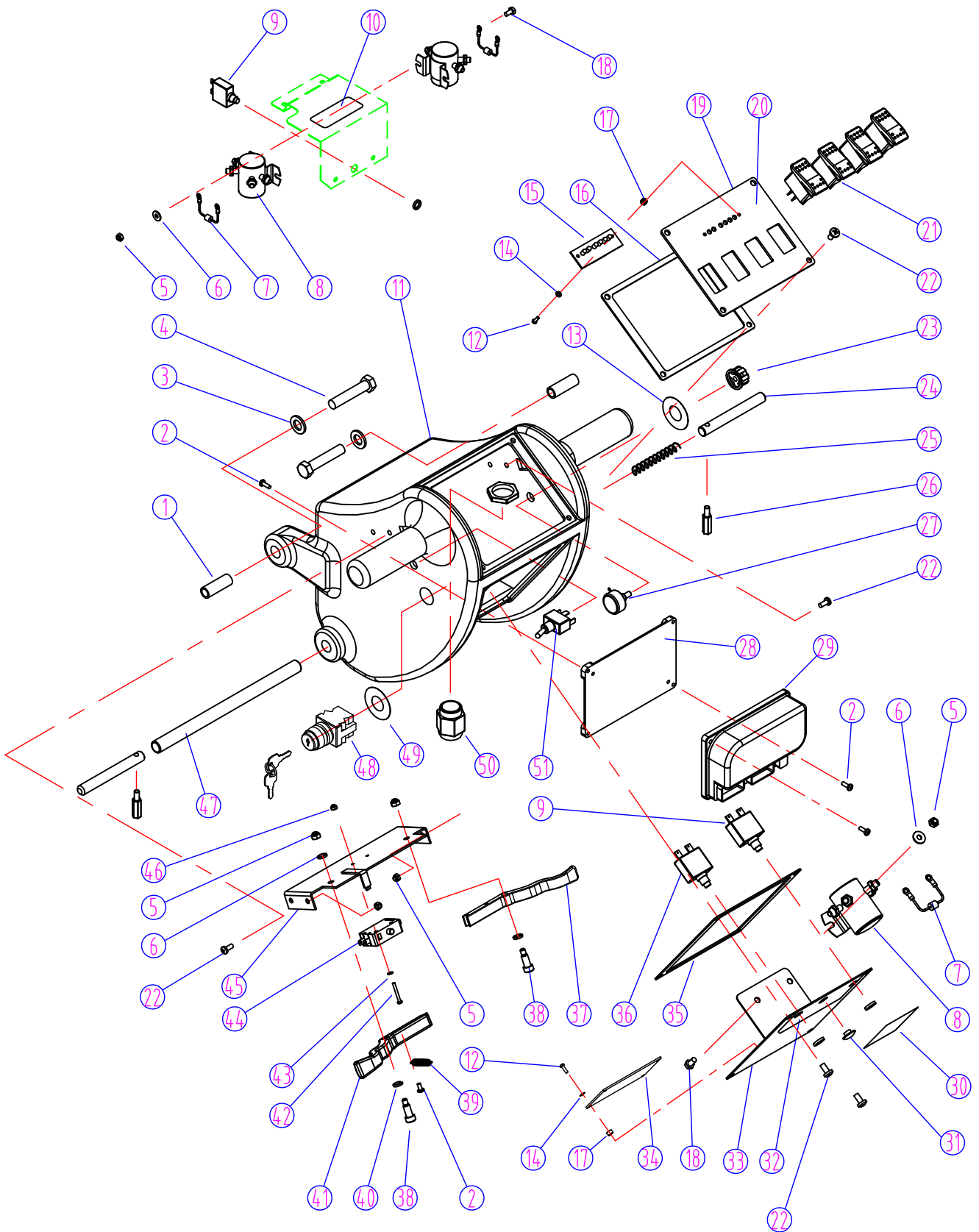



**FANG 20T - CONTROL HOUSING**

<b>DIA NO</b>	<b>PART NUMBER</b>	<b>DESCRIPTION</b>	<b>NO REQ'D</b>
1	VF81713	BUSHING	2
2	VF13491	SCREW, M4 X 12	7
3	VF14122	WASHER, PLAIN, M10 X M20 X 2	2
4	VF14121	SCREW, M10 X 65	2
5	VF13502	NUT, LOCK, M6	10
6	GT13032	WASHER, PLAIN, M6	6
7	VF81781	DIODE, 400V	3
	VF81781-X	DIODE WITH ENDS	3
8	VF81726A	SOLENOID, 24V	3
9	VF81734	BREAKER, CIRCUIT, 35 AMP	2
10	VF83149	LABEL, CIRCUIT BREAKER	1
11	VF82301	HOUSING, CONTROL	1
12	VF14078	SCREW, M3 X 10	6
13	VF82305	LABEL, SPEED CONTROL	1
14	VA50477	WASHER, PLAIN, M3 X M10 X 1	6
15	VF81718	LIGHTS, BATTERY CAPACITY	1
16	VF82313	GASKET	1
17	VF81719	SPACER	6
18	VF13495	SCREW, M6 X 16	4
19	VF82302A	PANEL, SWITCH	1
20	VF82304A	LABEL, SWITCH	1
21	VF81721	SWITCH, LIGHTED ROCKER	4
22	VF14200	SCREW, M6 X 16	12
23	VF81730	KNOB, SPEED CONTROL	1
24	VF81709	PIN, HANDLE LOCK	2
25	VF81716	SPRING	1
26	VF81710	PIN, HANDLE ADJUSTMENT	2
27	VF81732	POTENTIOMETER, 4.7K	1
28	VF82316	PLATE	1
29	VF81739-20T	SPEED CONTROL BOARD	1
30	VF82315	SERIAL TAG	1
31	GV40239	COVER	1
32	VF83148	LABEL, CIRCUIT BREAKER	1
33	VF82303A	PANEL, CONTROL HOUSING	1
34	VF81703	BATTERY CAPACITY, CONTROL BOARD	1
35	VF82312	GASKET	1
36	VF99012	BREAKER, CIRCUIT, 12 AMP	1
37	VF82107BD	HANDLE, RIGHT	1
38	VF81711	BOLT, SHOULDER, M8 X M15 X M6	2
39	VF81712	SPRING	1
40	VF13514A	WASHER, PLAIN, M8 X M16.5 X 1	2
41	VF82106BD	HANDLE, LEFT	1
42	VF14212	SCREW, M3 X 25	2
43	VF13511	WASHER, TOOTH, M3	2
44	VF44203	SWITCH ASSEMBLY	1
45	VF81707	BRACKET, SWITCH	1
46	VV13652	NUT, LOCK, M3	2
47	VF81714	TUBE, HANDLE,ADJUSTMENT	1
48	VF82153	SWITCH, KEY	1
49	VF82160	LABEL,KEY SWITCH	1
50	VF81744B	STRAIN RELIEF, CORD	1
51	VF81722	SWITCH, TOGGLE	1

PARTS LIST

FANG 20 & FANG 20T - RECOVERY TANK ASSEMBLY

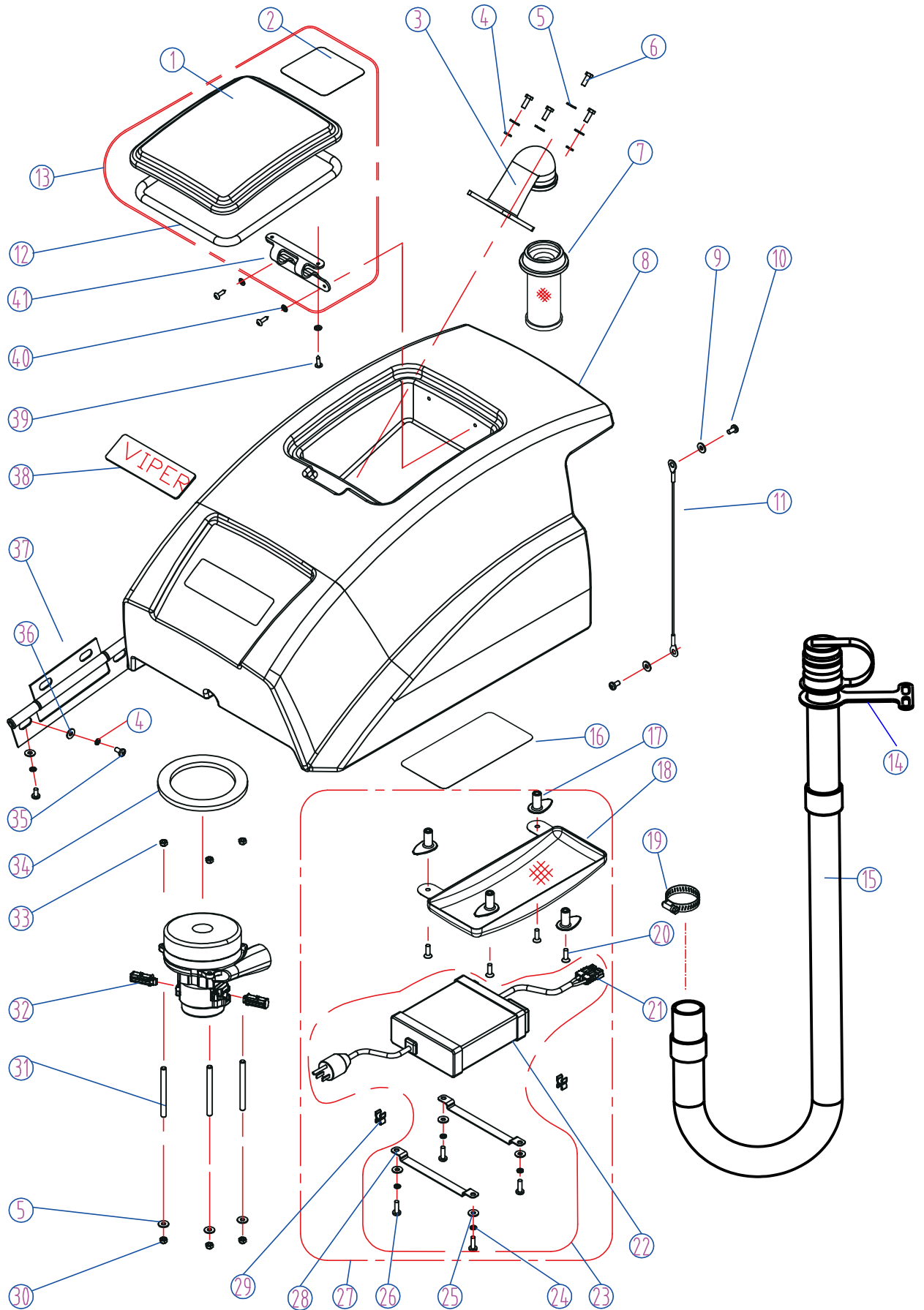

**FANG 20 & 20T - RECOVERY TANK ASSEMBLY**

<b>DIA NO</b>	<b>PART NUMBER</b>	<b>DESCRIPTION</b>	<b>NO REQ'D</b>
1	VF82010	CLEAR COVER, RECOVERY TANK	1
2	VF82083	DECAL, BATTERY WARNING	1
3	VF82009	ELBOW ADAPTOR, FLOAT	1
4	VV13607	WASHER, LOCK, M6	13
5	VF13533	WASHER, PLAIN, M6 X M16 X 2	7
6	VF14233	SCREW, M6 X 20	4
7	VF81504	FLOAT	1
8	VF82002	RECOVERY TANK	1
9	VF13528	WASHER, TOOTH, LOCK, M6	2
10	VF13495	SCREW, M6 X 16	2
11	VF82028	CABLE	1
12	VF82010B	GASKET	1
13	VF82010X	KIT,LID	1
14	VF84511	RUBBER HANG	1
15	VF81512	DRAIN HOSE	1
16	VF82115	DECAL, BATTERY INSTALLATION	1
17	VF82318	HOOK, CABLE	4
18	VF82326	MESH COVER, CABLE	1
19	VV10113	CLAMP, 2"	2
20	VF14225A	SCREW, M6 X 40	4
21	VF81723	CONNECTOR	1
22	VF82331	ON BOARD CHARGER, 9AMP, 24V	1
23	VF82332A	KIT,CHARGER REPLACEMENT	1
24	VV13601	WASHER, LOCK, M5	4
25	VF13532	WASHER, PLAIN, M5 X M11 X 2	4
26	VV20501	SCREW, M5 X 14	4
27	VF82331A	KIT, ON BOARD CHARGER	1
28	VF82332	CLAMP, CHARGER	2
29	VF82320	CLAMP, CABLE	2
30	VF13502	NUT, LOCK, M6	3
31	VF82310	STUD	3
32	ZD53000	MOTOR, VACUUM, 2 STAGE, 24VDC	1
33	VF13521	NUT,M6	3
34	VF81503	SEAT	1
35	VF14200	SCREW, M6 X 16	9
36	GT13032	WASHER, PLAIN, M6 X M16 X 1.5	9
37	VF81516	HINGE, RECOVERY TANK	1
38	VF82082	LOGO	1
39	VA13477	SCREW, SELF-TAPPING, ST, M4 X 16	4
40	VV13664	WASHER, PLAIN, M4 X M12 X 1	4
41	VF82010A	RUBBER HINGE	1

PARTS LIST

FANG 20 & FANG 20T - SOLUTION TANK ASSEMBLY

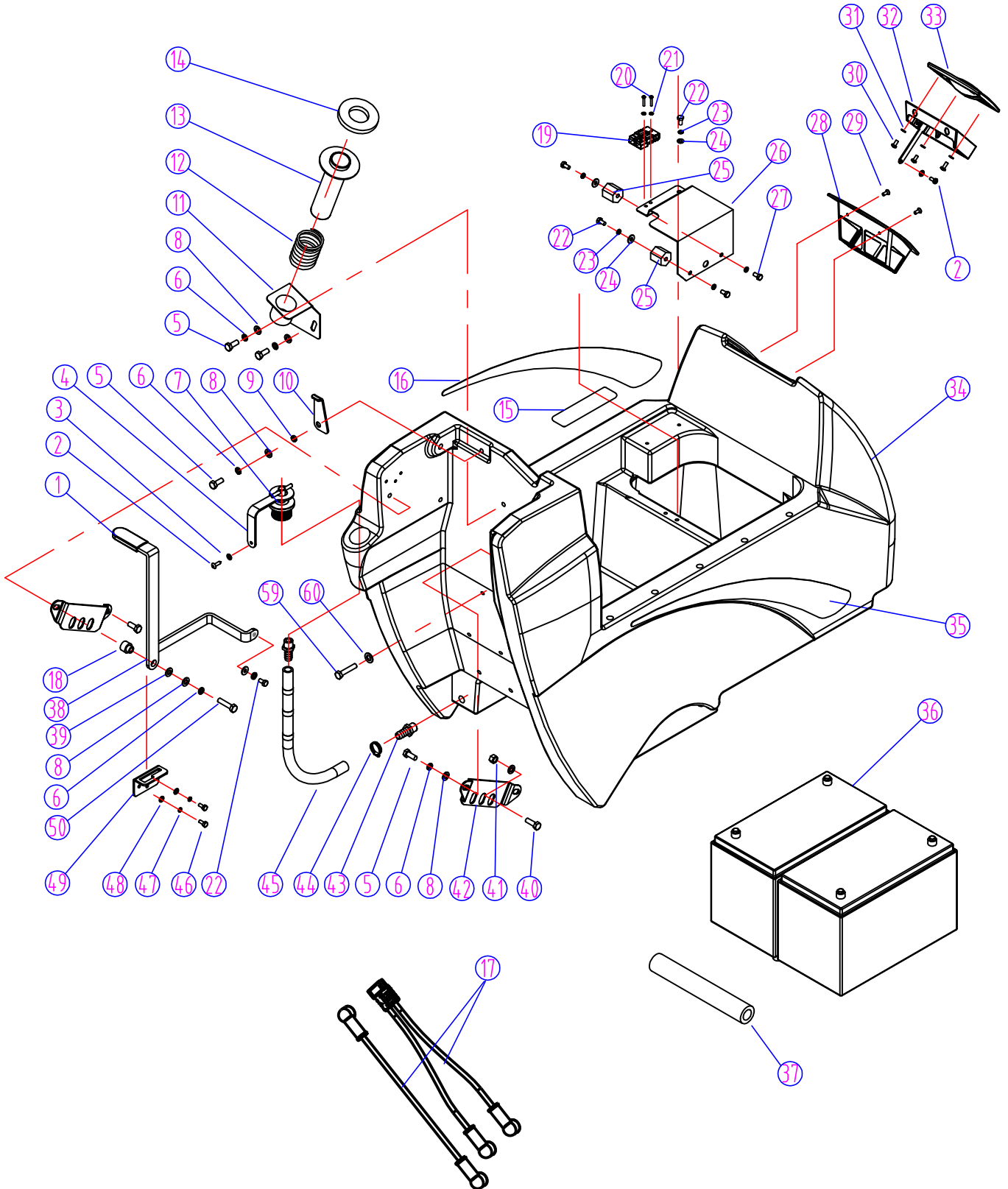

**FANG 20 & FANG 20T - SOLUTION TANK ASSEMBLY**

<b>DIA NO</b>	<b>PART NUMBER</b>	<b>DESCRIPTOIN</b>	<b>NO REQ'D</b>
1	VF81405	GRIP,HANDLE	1
2	VA13477	SELF-TAPPING SCREW,ST4X16	3
3	VV13664	WASHER,PLAIN,ϕ 4Xϕ 12X1	1
4	VF81507	STRAP,PLUG REAR FILL	1
5	VV13604	SCREW M8X20	6
6	VF13519	WASHER,LOCK,ϕ 8	6
7	VF81509	PLUG,EXPANSION	1
8	VF14535	WASHER,PLAIN,ϕ 8Xϕ 20X2	8
9	VF81406	BUSHING	1
10	VF81404	SUPPORT,RECOVERY TANK	1
11	VF82029A	BRACKET,VAC TUBE	1
12	VF82032	SPRING	1
13	VF82030	ADAPTER,TUBE	1
14	VF82031A	GASKET,TUBE ADAPTER	1
15	VF82123	DECAL	1
16	VF82070	LABEL,LEFT	1
17	VF82340	KIT,CONNECT WIRE	1
18	VF82050A	BUSHING	1
19	VF81723	CONNECTOR	1
20	VF13506A	SCREW M3X25	2
21	VF13511	WASHER	2
22	VF13495	SCREW M6X16	4
23	VV13607	WASHER,LOCK,ϕ 6	6
24	GT13032	WASHER,PLAIN,ϕ 6Xϕ 16X1.5	4
25	VF81715	STANDOFF	2
26	VF82067	BRACKET	1
27	VF14232	SCREW M6X10	2
28	VF82078	SCREEN,FILL	1
29	VF13543	SELF-TAPPING SCREW,ST4X16	2
30	VF13544	SELF-TAPPING SCREW,ST4X10	6
31	VA13483	WASHER,PLAIN,ϕ 4Xϕ 9X0.8	7
32	VF82081	PLUG,FILL SCREEN	1
33	VF82079	COVER,FILL SCREEN	1
34	VF82001A	SOLUTION TANK	1
35	VF82071	LABEL,RIGHT	1
36	VF82500	BATTERY, 12V DC (OPT)	2
37	VF82072	SPACER,BATTERY	1
38	VF82050	HANDLE,SQGE,LIFT	1
39	VF48216	WASHER LOCK	1
40	VF14234	SCREW M8X16	2
41	VF13513	NUT,M8	2
42	VF81408	PLATE,LOCK	2
43	VF81416	HOSE BARB	2
44	VF82161	CLAMP(16-25)	1
45	VF82061B	TUBING	1
46	VF14230	SCREW M5X15	3
47	VV13601	WASHER,LOCK,ϕ 5	3
48	VF13532	WASHER,PLAIN,ϕ 5Xϕ 11X2	3
49	VF81202	PLATE,SQGE,LOCK	1
50	VF14235	SCREW M8X35	1



PARTS LIST

FANG 20 & FANG 20T - SQUEEGEE ASSEMBLY

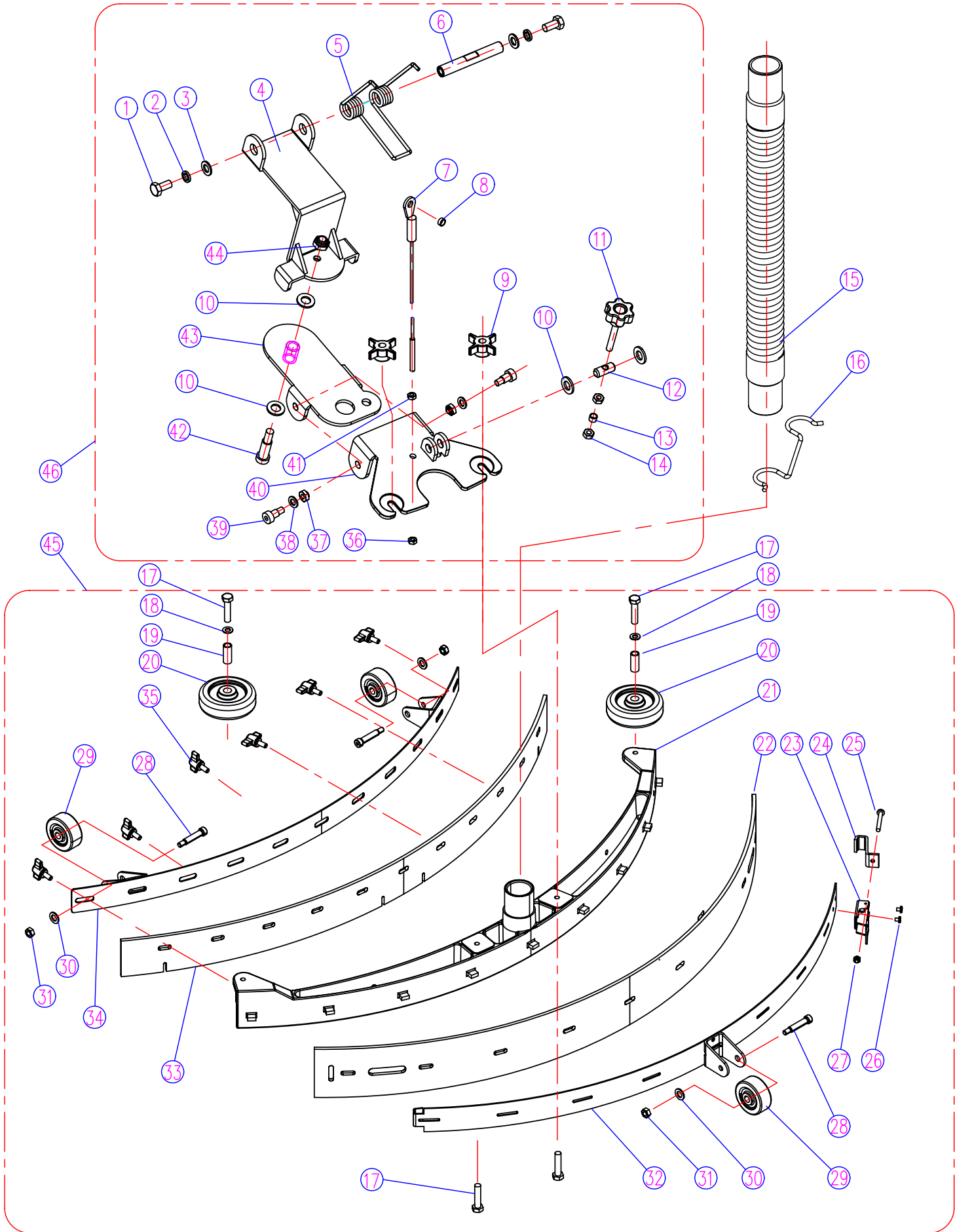

## FANG 20 &amp; FANG 20T - SQUEEGEE ASSEMBLY

DIA NO	PART NUMBER	DESCRIPTOIN	NO REQ'D
1	VF14123	SCREW M10X25	2
2	VF13518	WASHER,LOCK, $\phi$ 10	2
3	VF14122	WASHER, PLAIN, $\phi$ 10.2X $\phi$ 20X2	2
4	VF82170	FRONT SQUEEGEE SUPPORT	1
5	VF82172	SPRING	1
6	VF82173	SHAFT, SQUEEGEE SUPPORT	1
7#	VF81244	CABLE, SQGE, LIFT	1
8	VF82112	BUSHING	1
9	VF81210	KNOB, M8	2
10	VF85336	WASHER	4
11	VF85104	HANDWHEEL M8X55	1
12	VF85103	SUPPORT PIN	1
13	VF85106	BUSHING	1
14	VF14503	NUT, M8	2
15#	VF81203A	HOSE	1
16	VF83150	HOLDER "U" HOSE	1
17	VF14236	SCREW, M8X40	4
18	VF13514A	WASHER, PLAIN, $\phi$ 8X $\phi$ 16.5X1	2
19	VF82055	BUSHING	2
20	VF82013	WHEEL, 3"	2
21	VF82116	HOUSING,SQUEEGEE	1
22	VF82063	BLADE,SQUEEGEE,REAR (PU)	1
	VF82119	BLADE,SQUEEGEE,REAR (NEOPRENE)	1
23	VF81218A	LATCH,HOOD	1
24	VF81209	HOOK,REAR SQG,BRACKUP ADJUSTMENT	1
25	VF14305	SCREW,M5X60	1
26	VF81208A	RIVET, $\phi$ 4X5	2
27	GT13022	NUT,LOCK,M5	1
28	VF81222	BOLT,SHOULDER $\phi$ 9.5X31.5X5 / 16"	3
29	VF81219	WHEEL, 2"	3
30	VF13535	WASHER,PLAIN, $\phi$ 8X $\phi$ 20X2	3
31	VV20203	NUT,LOCK, 5/16"	3
32	VF82120	BACKUP STRIP,SQUEEGEE,REAR	1
33	VF82062	BLADE,SQEEGEE,FRONT (PU)	1
	VF82117	BLADE,SQUEEGEE,FRONT (NEOPRENE)	1
34	VF82118	BACKUP STRIP,SQUEEGEE,FRONT	1
35	VF82121	KNOB,M6	6
36	VF13502	MUT,LOCK,M6	1
37	VF14516	NUT,LOCK,M8	2
38	VF13542	WASHER,PLAIN, $\phi$ 8.5X $\phi$ 18X2	2
39	VF84228	BOLT,SHOULDER $\phi$ 10X $\phi$ 11.5XM8	2
40	VF84227	BRACKET SQUEEGEE,MOUNT	1
41	VF13521	NUT,M6	1
42	VF14527	BOLT,SHOULDER $\phi$ 12X30X M10	1
43	VF82171	BACK SQUEEGEE SUPPORT	1
44	VF14547	NUT,LOCK,M10	1
45	VF82908A	SQUEEGEE ASSY	1
46	VF82179	SQUEEGEE BRACKET ASSY	1

PARTS LIST

FANG 20 - BRUSH LIFT / WHEEL AXLE ASSEMBLY

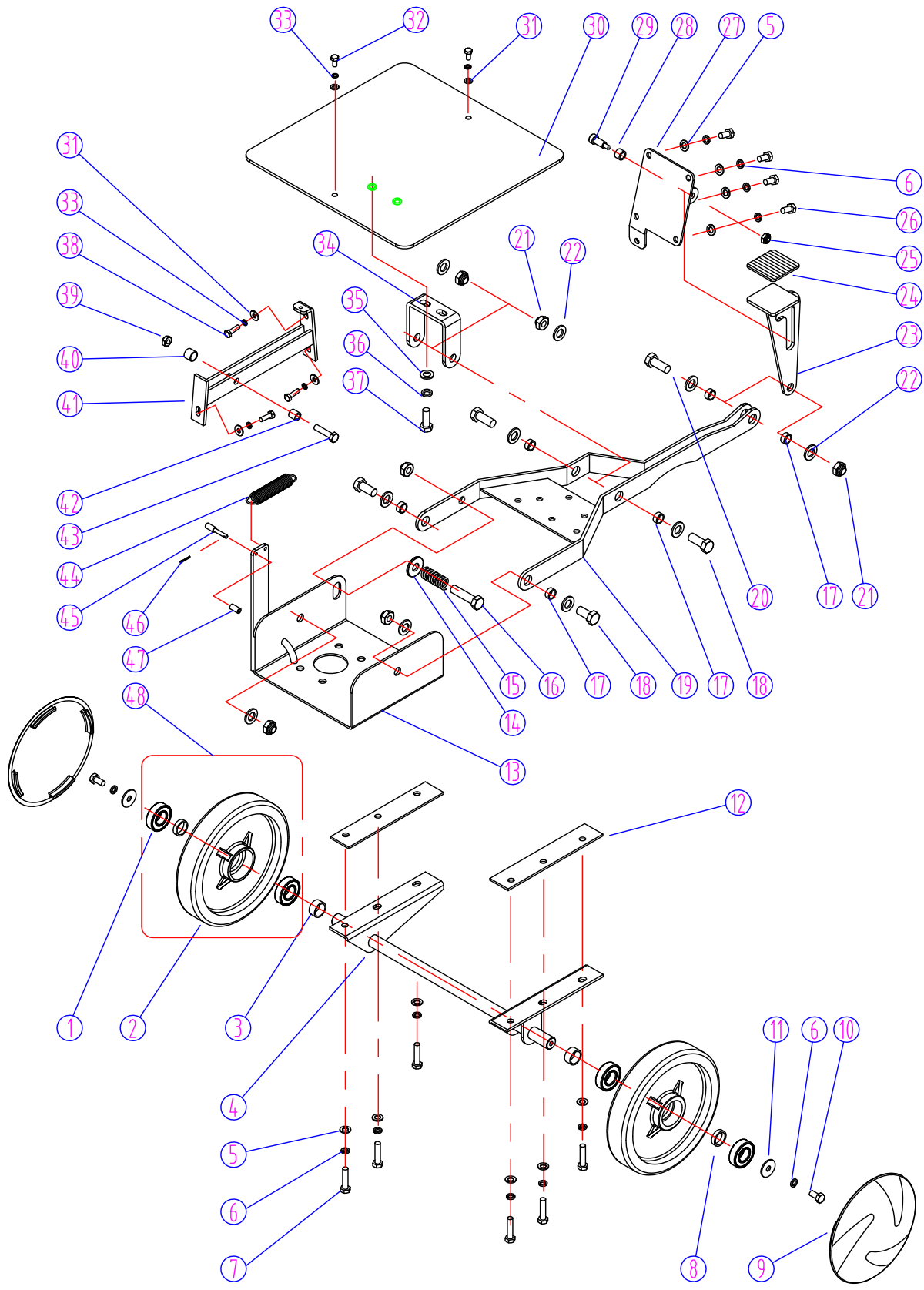

**FANG20 - BRUSH LIFT / WHEEL AXLE ASSEMBLY**

<b>DIA NO</b>	<b>PART NUMBER</b>	<b>DESCRIPTION</b>	<b>NO REQ'D</b>
1	VF14075	BEARING, #6004	4
2	VF82005	WHEEL, 8"	2
3	VF82101	BUSHING	2
4	VF82210	SHAFT	1
5	VF13535	WASHER, PLAIN, M8 X M20 X 2	10
6	VF13519	WASHER, LOCK, M8	12
7	VA13491	SCREW, M8 X 25	6
8	VF82113	BUSHING	2
9	VF82080	HUB, CAP	2
10	VF14234	SCREW, M8 X 16	2
11	VF13542	WASHER, PLAIN, M8 X M26 X 2	2
12	VF82206	SPACER	2
13	VF82017	BRACKET, MOTOR	1
14	VF82065	OILITE THRUST WASHER	1
15	VF82064	SPRING	1
16	VF14240	SCREW, M12 X 60	1
17	VF82016A	BUSHING	6
18	VF14238	SCREW, M12 X 30	4
19	VF82016	BRACKET, BRUSH LIFT	1
20	VF14239	SCREW, M12 X 35	1
21	VF13501	NUT, LOCK, M12	6
22	VF13538	WASHER, PLAIN, M12 X M22 X 2	5
23	VF82020	LATCH, BRUSH LIFT	1
24	VF81111	SPACER, RUBBER	1
25	VV20203	NUT, LOCK, 5/16"	1
26	VV13604	SCREW, M8 X 20	4
27	VF82021	BRACKET, BRUSH LIFT, LATCH	1
28	VF82021A	BUSHING	1
29	VF82021B	BOLT, SHOULDER	1
30	VF82023	MOUNT PLATE, BRUSH LIFT LATCH	1
31	VF13533	WASHER, PLAIN, M6 X M16 X 2	5
32	VF13495	SCREW, M6 X 16	2
33	VV13607	WASHER, LOCK, M6	5
34	VF82022	BRACKET, ADJUSTMENT	1
35	VF13537	WASHER, PLAIN, M10 X M26 X 2	2
36	VF13518	WASHER, LOCK, M10	2
37	VF14123	SCREW, M10 X 25	2
38	VF14233	SCREW, M6 X 20	3
39	VF13503	NUT, LOCK, M8	1
40	VF82018A	BUSHING	1
41	VF82018	ROLLER BRACKET, BRUSH LIFT	1
42	VF82018B	BUSHING	1
43	VF14236	SCREW, M8 X 40	1
44	VF81120	SPRING	1
45	VF82158	SHAFT	1
46	VF14096	PIN, M2X20	1
47	VF82159	BUSHING	1
48	VF82005A	KIT, WHEEL, 8"	1

FANG 20 & FANG 20T - SOLUTION CONTROL ASSEMBLY

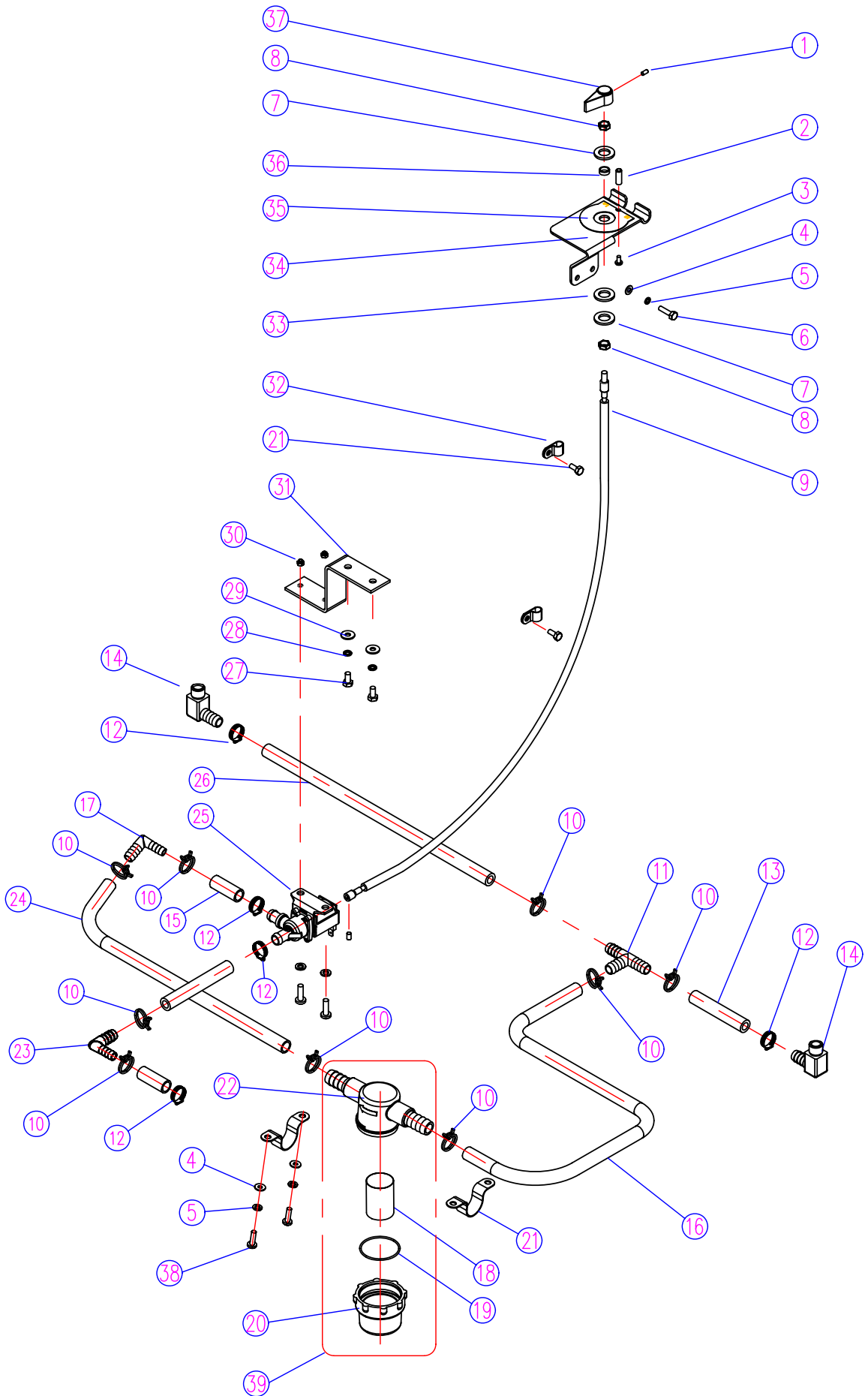



**FANG 20 & FANG 20T - SOLUTION CONTROL ASSEMBLY**

<b>DIA NO</b>	<b>PART NUMBER</b>	<b>DESCRIPTOIN</b>	<b>NO REQ'D</b>
1	VF14245	SCREW M5X6	2
2	VF82036	SHAFT	1
3	VV13650	SCREW M4X10	1
4	VF13532	WASHER,PLAIN, $\phi$ 5	6
5	VV13601	WASHER,LOCK, $\phi$ 5	7
6	VF14230	SCREW M5X15	2
7	VF13536	WASHER,PLAIN, $\phi$ 9.8X $\phi$ 16X1	2
8	VF82075	NUT, 3/8"	2
9	VF82035	CABLE,SOLENOID	1
10	VF82161	CLAMP, (16-25)	9
11	VF82040	HOSE BARB TEE	1
12	VF82148	CLAMP, 16mm	5
13	VF82138	TUBING, 70mm	1
14	VF81403A	ELBOW,SOLUTION TANK	2
15	VF82136-1	TUBING 45mm	1
16	VF82135	TUBING 400mm	1
17	VF82042	ELBOW	1
18	VF82168-4	MESH,FILTER	1
19	VF82168-5	"O"RING	1
20	VF82168-2	COVER,FILTER	1
21	VF82166	CLAMP	2
22	VF82168-3	SEAT, FILTER	1
23	VF82041	ELBOW,HOSE BARB	1
24	VF82136	TUBING 360mm	1
25	VF82033-20	SOLUTION SOLENOID, 24V DC	1
26	VF82137	TUBING 195mm	1
27	VF13495	SCREW M6X16	4
28	VV13607	WASHER,LOCK, $\phi$ 6	2
29	VF13533	WASHER,PLAIN, $\phi$ 6X $\phi$ 16X2	4
30	VF13502	NUT,LOCK,M6	2
31	VF82034A	BRACKET,SOLENOID	1
32	VF81118	CLAMP	3
33	VF13540	WASHER,WAVE, $\phi$ 12	2
34	VF82037	BRACKET,DRAIN HOSE & VALVE	1
35	VF82069	LABEL,VALVE	1
36	VF82074	BUSHING	1
37	VF82038	KNOB,VALVE ADJUST	1
38	VV20509	SCREW, M5X10	4
39	VF82168A	FILTER	1

# PARTS LIST

## FANG 20T - BRUSH LIFT / DRIVE ASSEMBLY

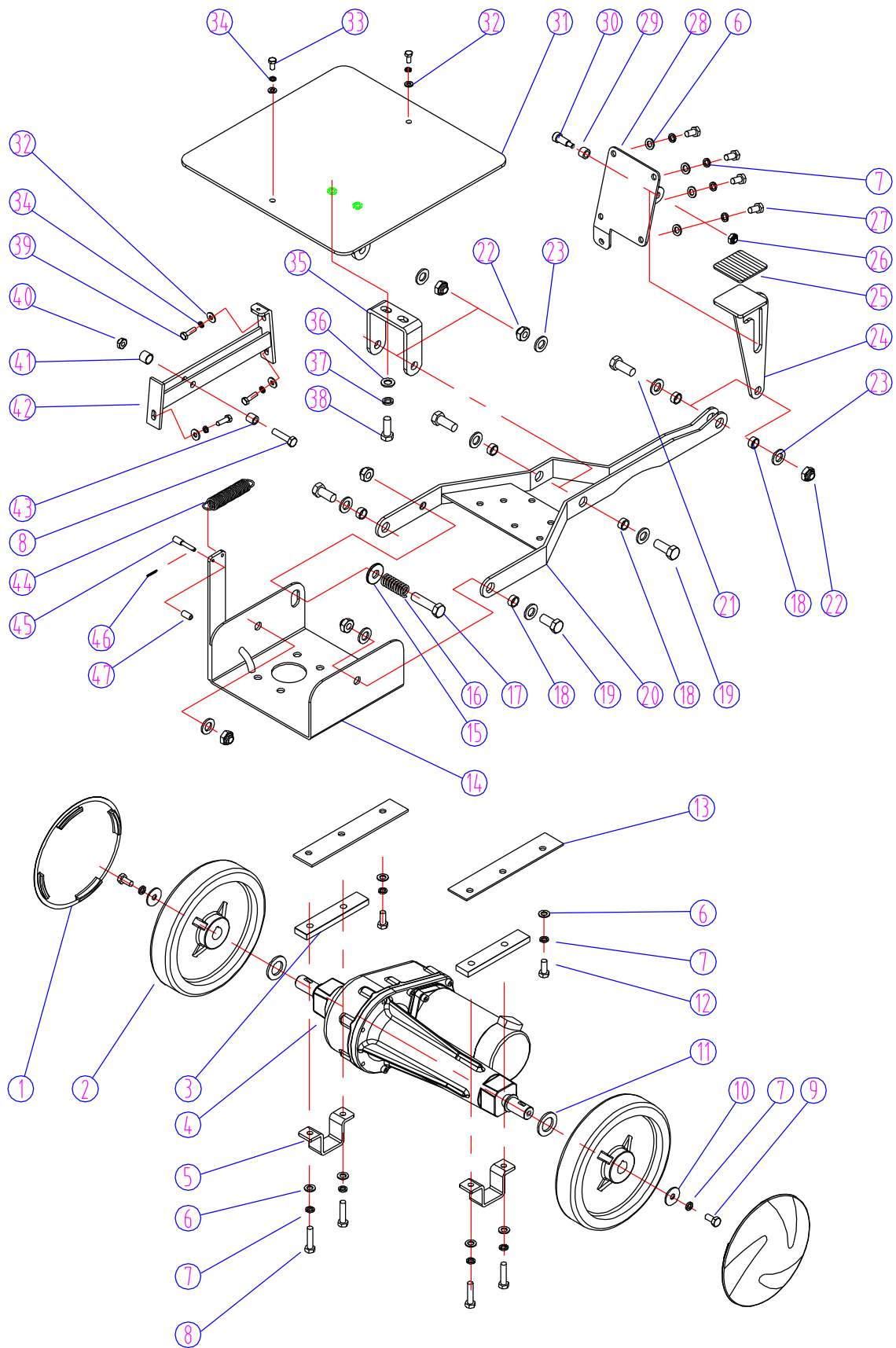

**FANG 20T - BRUSH LIFT/DRIVE ASSEMBLY**

<b>DIA NO</b>	<b>PART NUMBER</b>	<b>DESCRIPTION</b>	<b>NO REQ'D</b>
1	VF82080	HUB CAP	2
2	VF82006	WHEEL, 8" (Serial#1000 - 1499)	2
	VF82208	WHEEL, 8" (Serial#1500+)	2
3	VF82205	SPACER	2
4	VF82004	TRANSAXLE, 20"(Serial#1000 - 1499)	1
	VF82200	TRANSAXLE, 20" (Serial#1500+)	1
	ZD72000A	MOTOR,TRANSAXLE,24VDC (Serial#1500+)	1
	VF82207	KEY, 5 X 25 (Serial#1500+)	2
5	VF82204	BRACKET,TRANSAXLE MOUNT	2
6	VF13535	WASHER, PLAIN, M8 X M20 X 2	10
7	VF13519	WASHER, LOCK, F8	12
8	VF14236	SCREW, M8 X 40	5
9	VF14234	SCREW, M8 X 16	2
10	VF13546	WASHER, PLAIN, M8 X M28 X 2	2
11	VF82203	WASHER, PLAIN, M20 X M37 X 2	2
12	VF14234	SCREW, M8 X 16	2
13	VF82206	SPACER	2
14	VF82017	BRACKET, MOTOR	1
15	VF82065	OILITE THRUST WASHER	1
16	VF82064	SPRING	1
17	VF14240	SCREW, M12 X 60	1
18	VF82016A	BUSHING	6
19	VF14238	SCREW, M12 X 30	4
20	VF82016	BRACKET, BRUSH LIFT	1
21	VF14239	SCREW, M12 X 35	1
22	VF13501	NUT, LOCK, M12	6
23	VF13538	WASHER, PLAIN, M12 X M22 X 2	10
24	VF82020	LATCH, BRUSH LIFT	1
25	VF81111	SPACER, RUBBER	1
26	VV20203	NUT, LOCK, 5/16"	1
27	VV13604	SCREW, M8 X 20	4
28	VF82021	BRACKET, BRUSH LIFT, LATCH	1
29	VF82021A	BUSHING	1
30	VF82021B	BOLT, SHOULDER	1
31	VF82023	MOUNT PLATE, BRUSH LIFT LATCH	1
32	VF13533	WASHER, PLAIN, M6 X M16 X 2	5
33	VF13495	SCREW, M6 X 16	2
34	VV13607	WASHER, LOCK, M6	5
35	VF82022	BRACKET, ADJUSTMENT	1
36	VF13537	WASHER, PLAIN, M10 X M26 X 2	2
37	VF13518	WASHER, LOCK, M10	2
38	VF14123	SCREW, M10 X 25	2
39	VF14233	SCREW, M6 X 20	3
40	VF13503	NUT, LOCK, M8	1
41	VF82018A	BUSHING	1
42	VF82018	ROLLER BRACKET, BRUSH LIFT	1
43	VF82018B	BUSHING	1
44	VF81120	SPRING	1
45	VF82158	SHAFT	1
46	VF14096	PIN, M2 X 20	1
47	VF82159	BUSHING	1

# PARTS LIST

## FANG 20 & FANG 20T - BRUSH SKIRT ASSEMBLY

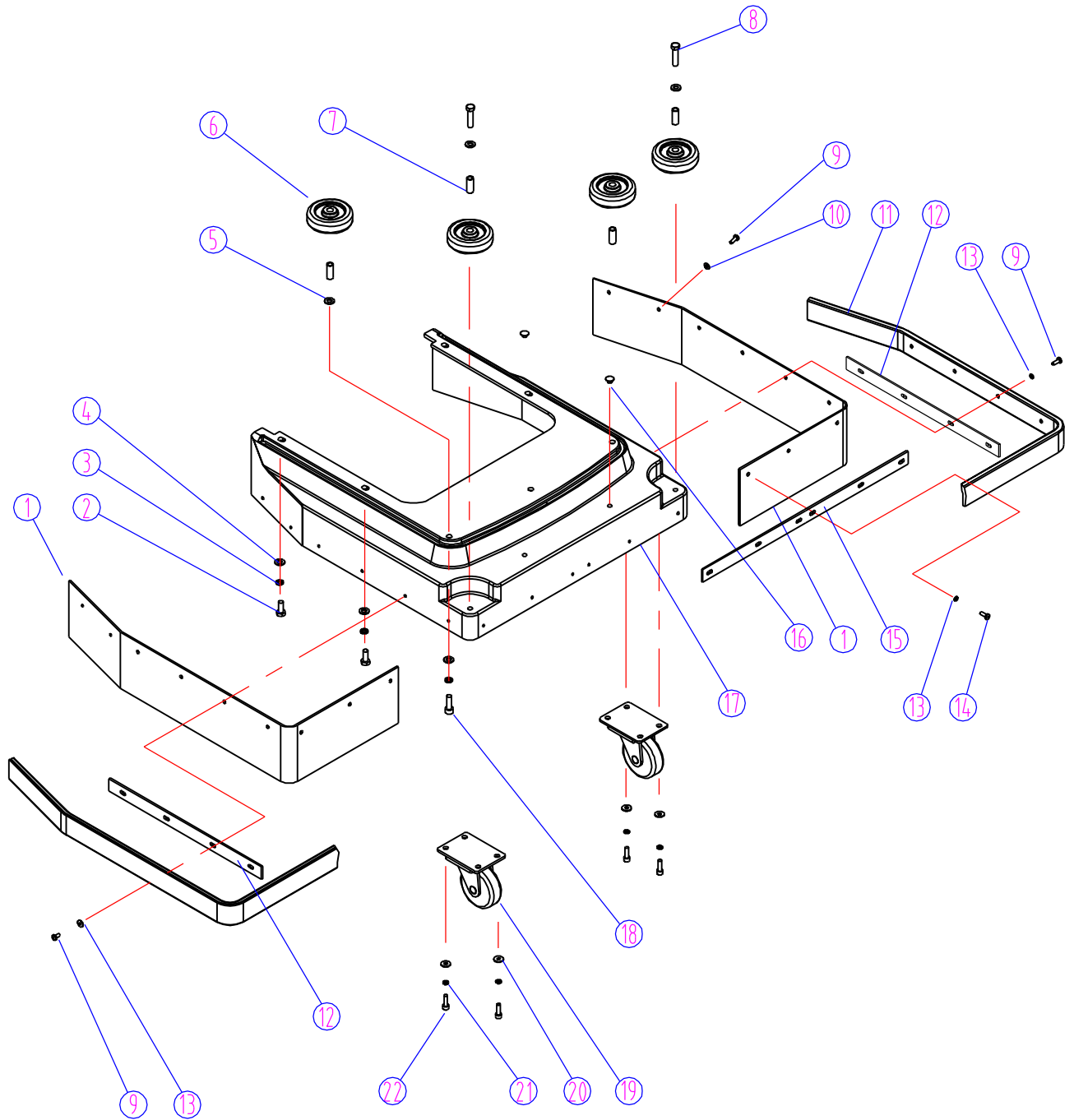

**FANG 20 & FANG 20T - BRUSH SKIRT ASSEMBLY**

<b>DIA NO</b>	<b>PART NUMBER</b>	<b>DESCRIPTION</b>	<b>NO REQ'D</b>
1	VF82014	BUMPER	2
2	VA13491	SCREW, M8 X 25	5
3	VF13519	WASHER, LOCK, M8	7
4	VF13535	WASHER, PLAIN, M8 X M20 X 2	7
5	VF13514A	WASHER, PLAIN, M8 X M16.5 X 1	4
6	VF82013	WHEEL, 3"	4
7	VF82055	BUSHING	4
8	VF14236	SCREW, M8 X 40	2
9	VA13474	SCREW, M5 X 16	14
10	VF13550	WASHER, PLAIN, M5 X M25 X 1.5	4
11	VF82068	GRIP, BUMPER	1
12	VF82127	CLAMP, BUMPER	2
13	VA13400	WASHER, PLAIN, M5 X M11 X 1	14
14	VV20509	SCREW, M5 X 10	4
15	VF82126	CLAMP, BUMPER	1
16	VF82060	COVER	2
17	VF82003	SKIRT	1
18	VF14243	SCREW, M8 X 45	2
19	VF82012A	CASTER, SWIVEL, 3"	2
20	VF13533	WASHER, PLAIN, M6	8
21	VV13607	WASHER, LOCK, M6	8
22	VF14233	SCREW, M6 X 20	8



FANG 20 & FANG 20T - BRUSH / PAD DRIVE ASSEMBLY

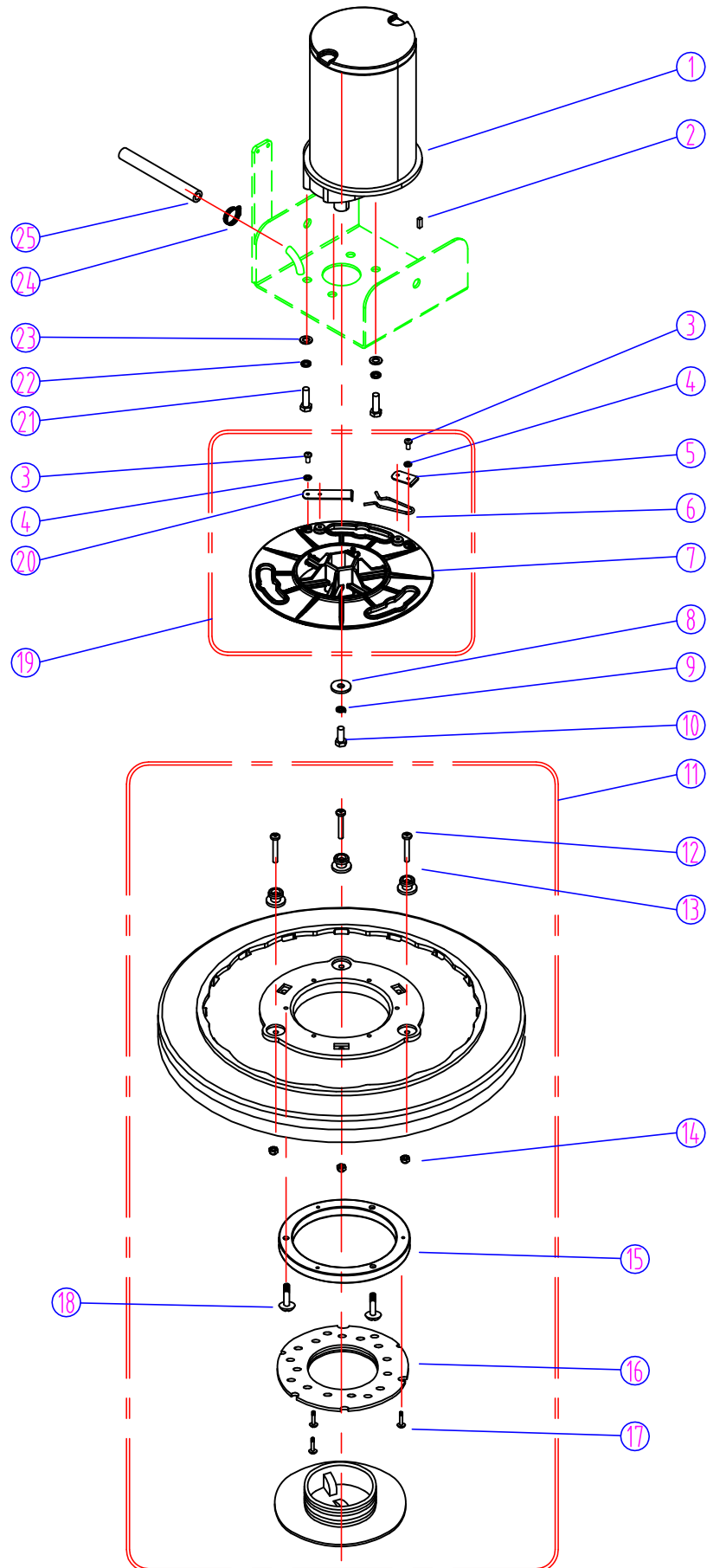

**FANG20 & 20T - BRUSH / PAD DRIVE ASSEMBLY**

<b>DIA NO</b>	<b>PART NUMBER</b>	<b>DESCRIPTION</b>	<b>NO REQ'D</b>
1	ZD45000	BRUSH MOTOR, 24VDC, .75HP	1
2	ZD45407	KEY, 6.35 X 25	1
3	VF13545	SCREW, SELF-TAPPING,ST, M5 X 10	4
4	VV13601	WASHER, LOCK, M5	4
5	VF83131	CLAMP, BRUSH PLATE	1
6	VF83132	SPRING	1
7	VF83130	PLATE, DRIVE	1
8	VF82058	WASHER	1
9	VV20298	WASHER, LOCK, 5/16"	1
10	VF14241	SCREW, 5/16"-1"	1
11	VF82057	PAD DRIVER, 19"	1
12	VF14225A	SCREW, M6 X 40	3
13	VF83133	STUD	3
14	VF13502	NUT, LOCK, M6	3
15	VF83118	SPACER	1
16	VF99003A	BIG MOUTH	1
17	VA13484	SCREW, SELF-TAPPING,ST, M4 X 12	3
18	MF-VF002-4A	SCREW, SELF-TAPPING, 1/4"-1"	3
19	VF83130A	PLATE, DRIVE, ASSY	1
20	VF83134	STOP, DRIVE RELEASE	1
21	VF14242	SCREW, 3/8"-1	4
22	VV13620	WASHER, LOCK, 3/8"	4
23	VF13537	WASHER, PLAIN, M10 X M26 X 2	4
24	VF82148	CLAMP, 16mm	1
25	VF82077	TUBING, 55mm	1

# WIRING DIAGRAM FOR FANG 20T

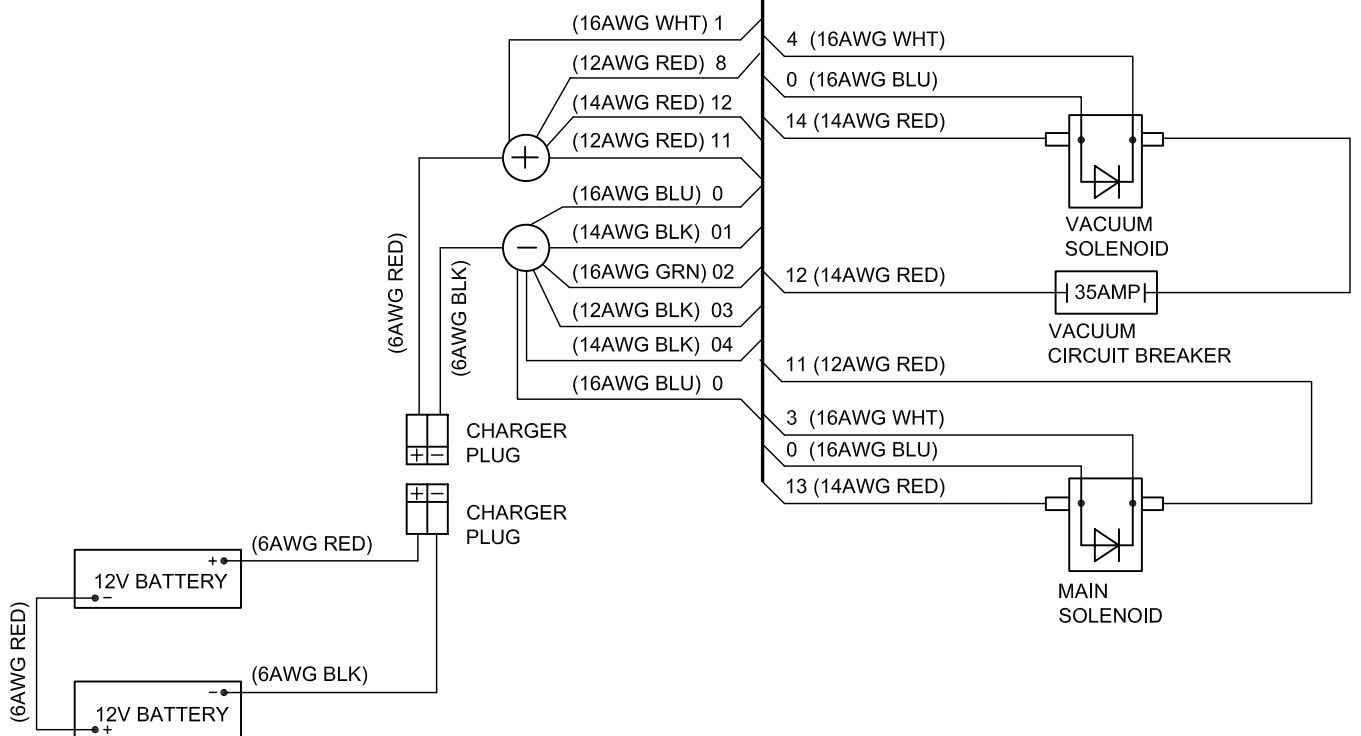
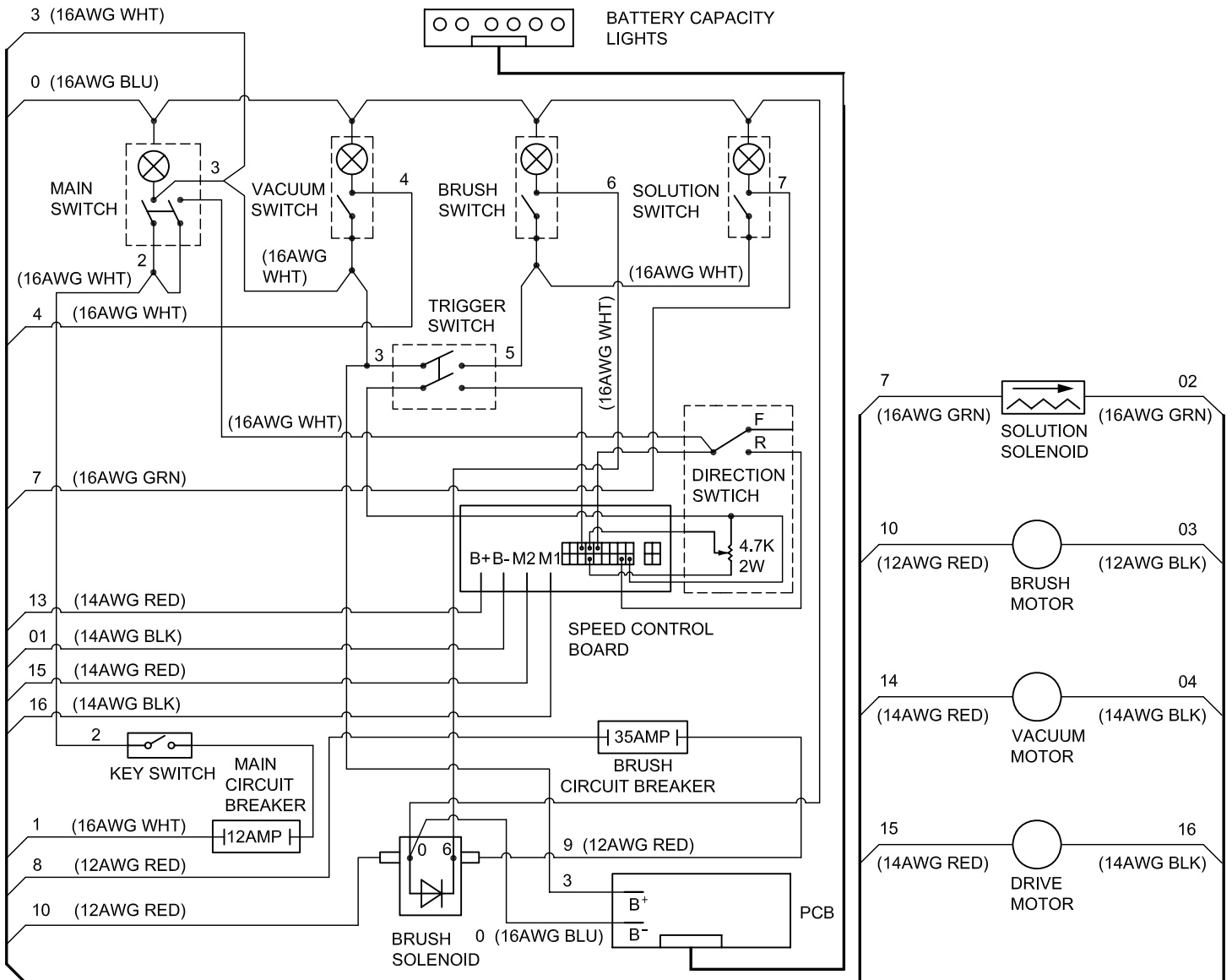

# WIRING DIAGRAM FOR FANG 20

