



# 1230

Self-Contained Carpet Extractor

**Model No.:**  
**609392 – 120V**  
**609384 – 230V**  
**609684 – 240V EMC**

**Operator and Parts Manual**

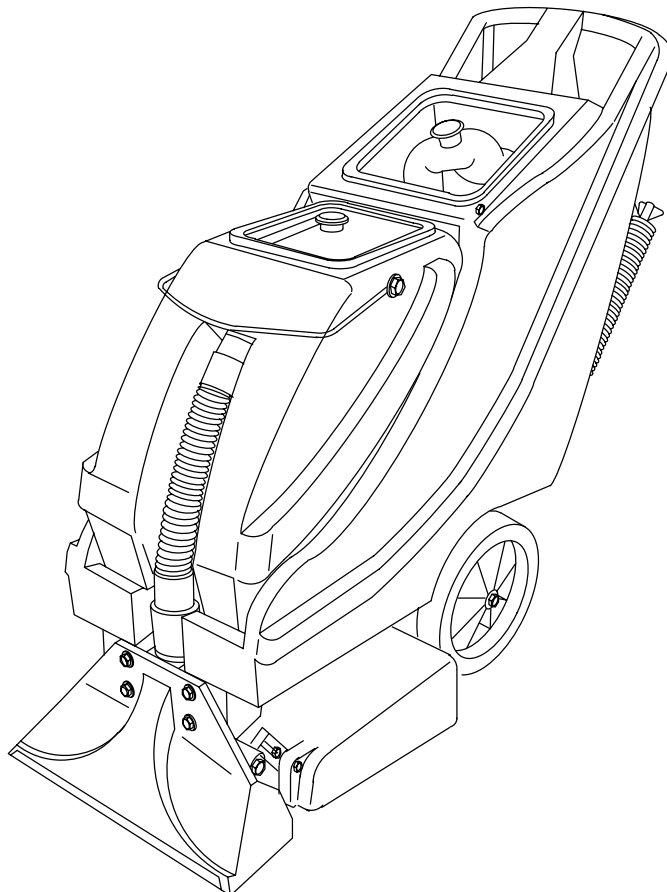

**TENNANT COMPANY**  
**Commercial Products**  
12875 RANSOM STREET  
HOLLAND MI 49424 U.S.A.

**FAX: 1-800-678-4240**  
**CUSTOMER SERVICE: 1-800-982-7658**

**609743**  
**Rev. 00 (01-00)**

---

# IMPORTANT SAFETY INSTRUCTIONS

When using an electrical appliance, basic precautions should always be followed, including the following:

## READ ALL INSTRUCTIONS BEFORE USING (THIS APPLIANCE)

**⚠ WARNING** – To reduce the risk of fire, electric shock, or injury:

1. Do not leave appliance when plugged in. Unplug from outlet when not in use and before servicing.
2. Do not use outdoors or on wet surfaces.
3. Do not allow to be used as a toy. Close attention is necessary when used by or near children.
4. Use only as described in this manual. Use only manufacturer's recommended attachments.
5. Do not use with damaged cord or plug. If appliance is not working as it should, has been dropped, damaged, left outdoors, or dropped into water, return it to a service center.
6. Do not pull or carry by cord, use cord as a handle, close a door on cord, or pull cord around sharp edges or corners. Do not run appliance over cord. Keep cord away from heated surfaces.
7. Do not unplug by pulling on cord. To unplug, grasp the plug, not the cord.
8. Do not handle plug or appliance with wet hands.
9. Do not put any object into openings. Do not use with any opening blocked; keep free of dust, lint, hair, and anything that may reduce air flow.
10. Keep hair, loose clothing, fingers, and all parts of body away from openings and moving parts.
11. Do not pick up anything that is burning or smoking, such as cigarettes, matches, or hot ashes.
12. Do not use without filters and/or dust bag in place.
13. Turn off all controls before unplugging.
14. Use extra care when cleaning on stairs.
15. Do not use to pick up flammable or combustible liquids such as gasoline or use in areas where they may be present.
16. For grounded appliance: "Connect to a properly grounded outlet only. See Grounding Instructions."

---

# LIRE TOUTES LES INSTRUCTIONS AVANT DE FAIRE FONCTIONNER

(CET APPAREIL)

**⚠ ADVERTISSEMENT** – Pour réduire les risques d'incendie, de choc électrique ou de blessure:

1. Ne pas laisser l'appareil sans surveillance lorsqu'il est branché. Débrancher lorsque l'appareil n'est pas utilisé et avant l'entretien.
2. Ne pas utiliser à l'extérieur et ne pas aspirer de matières humides.
3. Ne pas permettre aux enfants de jouer avec l'appareil. Une attention particulière est nécessaire lorsque l'appareil est utilisé par des enfants ou à proximité de ces derniers.
4. Utiliser que conformément à cette notice avec les accessoires recommandés par le fabricant.
5. Ne pas utiliser si le cordon ou la fiche est endommagé. Retourner l'appareil à un atelier de réparation s'il ne fonctionne pas bien, s'il est tombé ou s'il a été endommagé, oublié à l'extérieur ou immergé.
6. Ne pas tirer, soulever ou traîner l'appareil par le cordon. Ne pas utiliser le cordon comme une poignée, le coincer dans l'embrasure d'une porte ou l'appuyer contre des arêtes vives ou des coins. Ne pas faire rouler l'appareil sur le cordon. Garder le cordon à l'écart des surfaces chaudes.
7. Ne pas débrancher en tirant sur le cordon. Tirer plutôt la fiche.
8. Ne pas toucher la fiche ou l'appareil lorsque vos mains sont humides.
9. N'insérer aucun objet dans les ouvertures. Ne pas utiliser l'appareil lorsqu'une ouverture est bloquée. S'assurer que de la poussière, de la peluche, des cheveux ou d'autres matières ne réduisent pas le débit d'air.
10. Maintenir les cheveux, les vêtements amples, les doigts et toutes les parties du corps à l'écart des ouvertures et des pièces mobiles.
11. Ne pas aspirer de matières en combustion ou qui dégagent de la fumée, comme des cigarettes, des allumettes ou des dendres chaudes.
12. Ne pas utiliser l'appareil si le sac à poussière ou le filtre n'est pas en place.
13. Mettre toutes les commandes à la position ARRÊT avant de débrancher l'appareil.
14. User de prudence lors du nettoyage des escaliers.
15. Ne pas aspirer des liquides inflammables ou combustibles, comme de l'essence, et ne pas faire fonctionner dans des endroits où peuvent se trouver de tels liquides.

---

## GROUNDING INSTRUCTIONS

This appliance must be grounded. If it should malfunction or breakdown, grounding provides a path of least resistance for electric current to reduce the risk of electric shock. This appliance is equipped with a cord having an equipment–grounding conductor and grounding plug. The plug must be plugged into an appropriate outlet that is properly installed and grounded in accordance with all local codes and ordinances.

**⚠ WARNING – Improper connection of the equipment–grounding conductor can result in a risk of electric shock. Check with a qualified electrician or service person if you are in doubt as to whether the outlet is properly grounded. Do not modify the plug provided with the appliance – if it will not fit the outlet, have a proper outlet installed by a qualified electrician.**

This appliance is for use on a nominal 120–volt circuit and has a grounding attachment plug that looks like the plug illustrated in sketch. Make sure that the appliance is connected to an outlet having the same configuration as the plug. No adaptor should be used with this appliance.

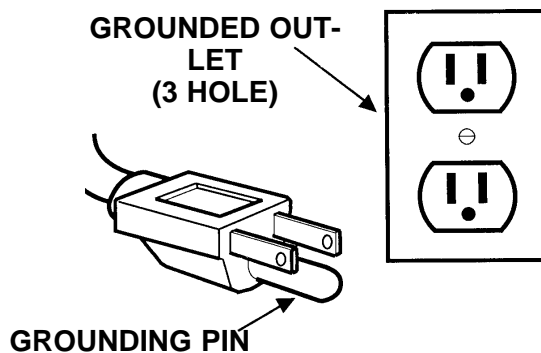

## INSTRUCTIONS VISANT LA MISE 'A LA TERRE

Cet appareil doit être mis à la terre. En cas de défaillance ou de panne éventuelles, la mise à la terre fournit au courant un chemin de moindre résistance qui réduit le risque de choc électrique. Cet appareil est pourvu d'un cordon muni d'un conducteur de terre et d'une fiche avec broche de terre. La fiche doit être branchée dans une prise appropriée correctement installée et mise à la terre conformément aux règlements et ordonnances municipaux.

**AVERTISSEMENT. Un conducteur de terre mal raccordé peut entraîner un risque de choc électrique. Consulter un électricien ou un technicien d'entretien qualifié si vous n'êtes pas certain que la prise est correctement mise à la terre. Ne pas modifier la fiche fournie avec l'appareil – si elle ne peut être insérée dans la prise, faire installer une prise adéquate par un électricien qualifié.**

Cet appareil est destiné à un circuit de 120 v et est muni d'une fiche de mise à la terre semblable à celle illustrée par le croquis. S'assurer que l'appareil est branché à une prise de courant ayant la même configuration que la fiche. Aucun adaptateur ne devrait être utilisé avec cet appareil.

This manual is furnished with each new model. It provides necessary operation and maintenance instructions and an illustrated parts list.

**Read this manual completely and understand the machine before operating or servicing it.**

Use the illustrated parts list to order replacement parts and options. Before ordering parts or supplies, be sure to have your machine model number and serial number handy. Parts and supplies may be ordered by phone or mail from any authorized parts and service center, distributor or from any subsidiary.

This machine will provide excellent service. However, the best results will be obtained at minimum costs if:

- The machine is operated with reasonable care.
- The machine is maintained regularly - per the machine care instructions provided.
- The machine is maintained with manufacturer supplied or equivalent parts.

**MACHINE DATA**

Please fill out at time of installation for future reference.

Model No.- \_\_\_\_\_ Install. Date - / /

Serial No.- \_\_\_\_\_

©2000 Tennant Company

Printed in U.S.A.

**TABLE OF CONTENTS**

<b>SAFETY PRECAUTIONS</b> .....	6	RINSING SOLUTION SYSTEM .....	18
GROUNDING INSTRUCTIONS .....	6	SOLUTION DISPENSING NOZZLES	
SAFETY LABELS .....	7	AND VACUUM INLET .....	18
<b>SPECIFICATIONS</b> .....	8	FREEZE PROTECTION .....	19
<b>MACHINE COMPONENTS</b> .....	9	<b>TROUBLESHOOTING</b> .....	20
<b>OPERATION</b>		<b>STANDARD PARTS</b>	
OPERATION OF CONTROLS .....	10	MAIN FRAME AND PLUMBING GROUP .....	22
PRE-OPERATION .....	10	RECOVERY TANK GROUP .....	24
TRANSPORTING MACHINE .....	10	SOLUTION TANK GROUP .....	26
HOW THE MACHINE WORKS .....	10	POWERBRUSH GROUP .....	30
FILLING THE SOLUTION TANK .....	10	ELECTRICAL PANEL GROUP .....	32
PREPARING FLOOR FOR CLEANING .....	11	<b>ELECTRICAL SCHEMATIC</b> .....	34
CLEANING CARPETS .....	12	<b>BREAKDOWNS</b>	
EMPTYING AND CLEANING		PUMP MOTOR .....	35
THE SOLUTION TANK .....	13	VACUUM MOTOR .....	36
EMPTYING AND CLEANING		<b>OPTIONS</b>	
THE RECOVERY TANK .....	14	CARPET WAND .....	37
POST-OPERATION .....	15	HARD FLOOR WAND .....	38
<b>OPTIONAL ATTACHMENT TOOLS</b>		UPHOLSTERY TOOL .....	40
OPERATION OF ATTACHMENTS .....	16	HOSE ASSEMBLY .....	40
<b>MAINTENANCE</b>			
MAINTENANCE REQUIREMENTS .....	18		
DAILY .....	18		
WEEKLY .....	18		
MONTHLY .....	18		
EVERY SIX MONTHS .....	18		
SOLUTION SYSTEM .....	18		

## SAFETY PRECAUTIONS

The following symbol is used throughout this manual as indicated in the descriptions below:

**!** **CAUTION:** To warn of hazards or unsafe practices which could result in minor personal injury.

**!** **WARNING:** To warn of hazards or unsafe practices which could result in severe personal injury or death.

**FOR SAFETY:** To identify actions which must be followed for safe operation of equipment.

The following information signals potentially dangerous conditions to the operator or equipment. Read this manual carefully. Know when these conditions can exist. Locate all safety devices on the machine. Then, take necessary steps to train machine operating personnel. Report machine damage or faulty operation immediately. Do not use the machine if it is not in proper operating condition.

**FOR SAFETY:**

1. Do not operate, maintain, or service machine:
  - Unless trained and authorized.
  - Unless operation manual is read and understood.
  - In flammable or explosive areas
  - With damaged cord or plug
  - In outdoor areas
2. Before operating machine:
  - Make sure all safety devices are in place and operate properly.
3. When maintaining or servicing machine:
  - Unplug power cord from outlet.
  - Avoid moving parts. Do not wear loose jackets, shirts, ties, or sleeves when working on machine.
  - Use manufacturer supplied or approved replacement parts.
4. When using machine:
  - Do not pull machine by plug or cord
  - Keep cord away from heated surfaces
  - Do not unplug by pulling on cord

**!** **WARNING:** Hazardous Voltage. Shock Or Electrocutation Can Result. Unplug Power Cord Before Working On Machine.

**!** **WARNING:** Flammable Materials Can Cause An Explosion Or Fire. Do Not Use Flammable Materials In Solution Tank.

**!** **WARNING:** Flammable Materials Or Reactive Metals Can Cause An Explosion Or Fire. Do Not Pick Up Flammable Materials Or Reactive Metals.

**!** **CAUTION:** Moving parts. Unplug Power Cord Before Working On Machine.

## GROUNDING INSTRUCTIONS

This machine must be grounded. If it should malfunction or breakdown, grounding provides a path of least resistance for electrical current to reduce the risk of electric shock. This machine is equipped with a cord having an equipment-grounding conductor and grounding plug. The plug must be plugged into an appropriate outlet that is properly installed in accordance with all local codes and ordinances. Do not remove ground pin, if missing replace plug before use.

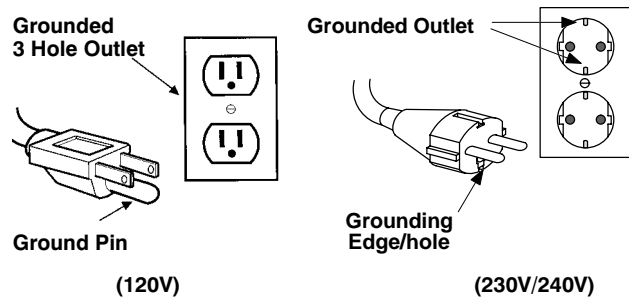

**FOR SAFETY:** Connect to properly grounded outlet only.

Store the machine indoors, do not expose to rain.

This product is intended for commercial use.

**SAFETY LABELS**

The following safety labels are mounted on the machine in the locations indicated. If these or any label becomes damaged or illegible, install a new label in its place.

**FLAMMABLE SPILLS LABEL – LOCATED ON THE SOLUTION TANK COVER.**

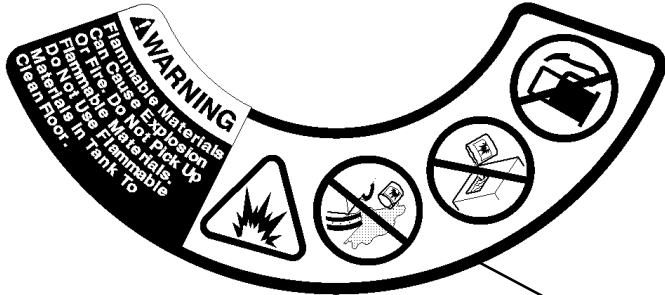

**FOR SAFETY LABEL – LOCATED ON THE MACHINE HANDLE FRAME.**

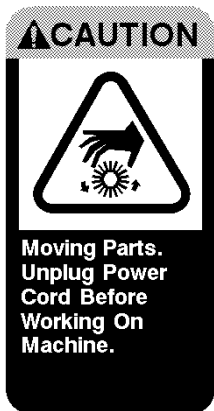
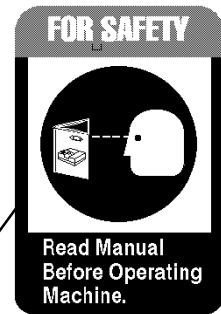

**MOVING PARTS LABEL – LOCATED ON THE SCRUB HEAD.**

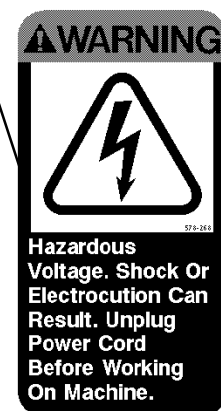

**HAZARDOUS VOLTAGE LABEL – LOCATED ON THE REAR PANEL OF THE MACHINE.**

# OPERATION

## SPECIFICATIONS

### POWER TYPE

Electric, 120V or 230 V/240V, 50–60 Hz

### POWER TRAIN

Electric motor, belt driven brush  
Electric motor, vacuum fan  
Electric motor, solution pump

### PROPELLING SYSTEM

Manually propelled with brush assist in forward

### SUSPENSION SYSTEM

Wheels– (2) rear, 250mm (10 in) dia

### SYSTEM REFILL FLUID CAPACITIES

Solution tank – 34 L (9 gal)  
Recovery tank – 19 L (5 gal)  
Combined capacity in recycle cleaning mode–  
53 L (14 gal)

### GENERAL MACHINE DIMENSIONS

Length – 760mm (30 in)  
Width – 510mm (20 in)  
Height – 880mm (35 in)  
Cleaning path width – 430mm (17 in)  
Brush width – 360mm (14 in)  
Brush diameter – 90mm (3.4 in)  
Power cord – 12m (40ft)

### MACHINE WEIGHT

Empty solution/recovery tank – 51kg (111lb)  
Full solution Tank – 84.4kg (186lb)  
Full solution/recovery tank – 103.4kg (228lb)  
Shipping Weight – 54kg (119lb)

### DIMENSIONS

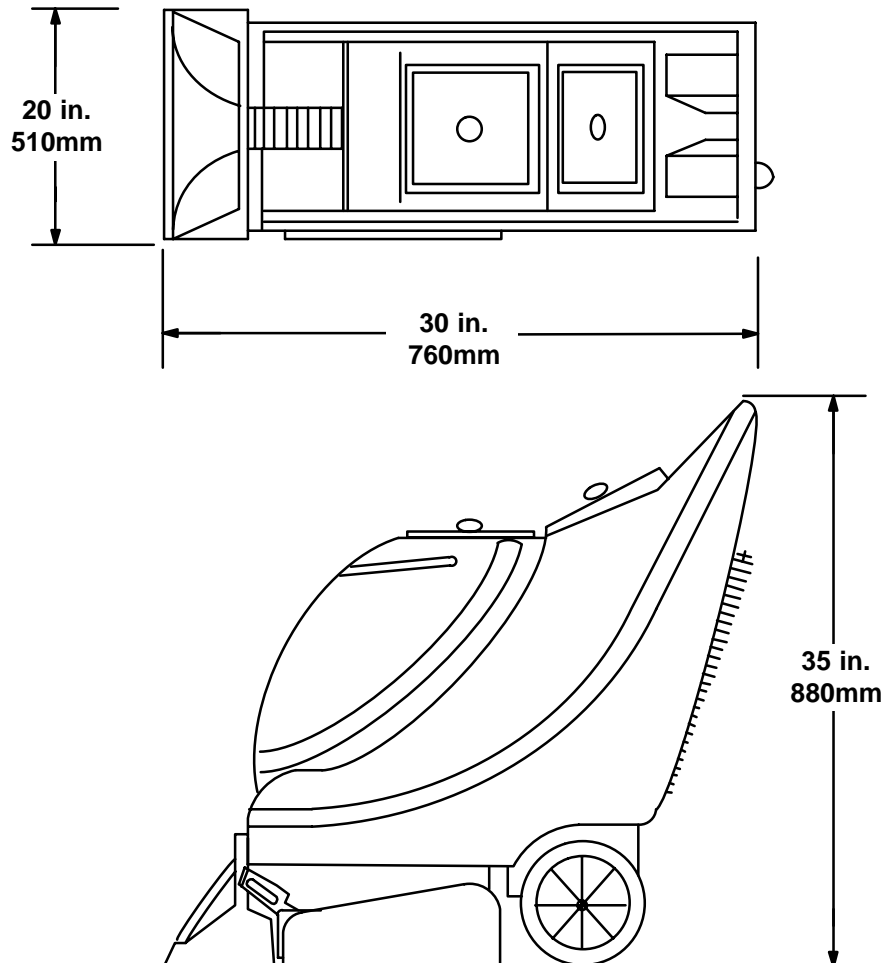



**MACHINE COMPONENTS**

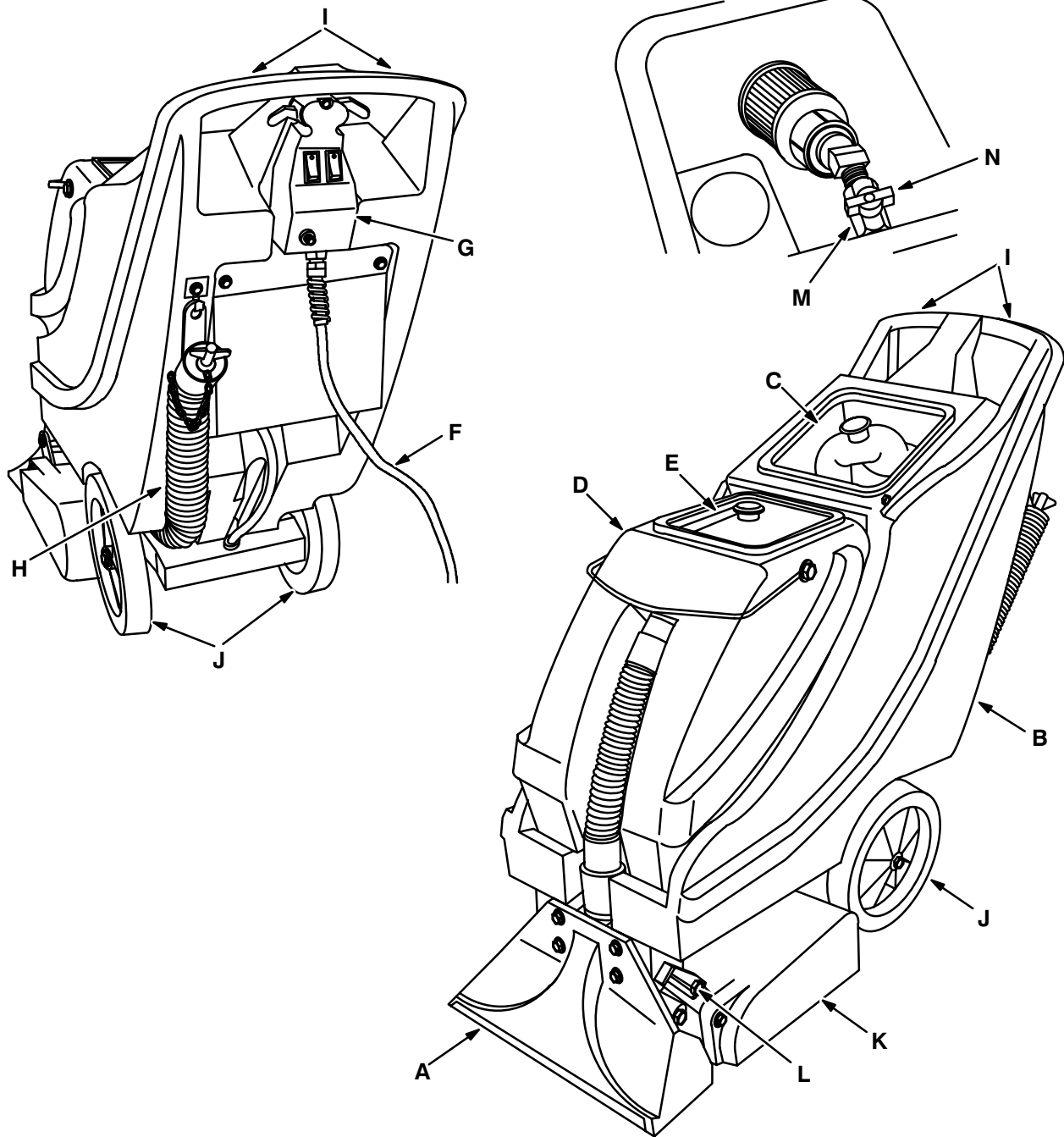

- A. Intake Head
- B. Solution Tank
- C. Solution Tank Cover
- D. Recovery Tank
- E. Recovery Tank Cover
- F. Power Cord
- G. Control Panel
- H. Drain Hose
- I. Control Handles
- J. Rear Wheels
- K. Powerbrush Head
- L. Powerbrush Storage Latch
- M. Recycle Valve (recycle model)
- N. Recycle Valve Selector Handle (recycle model)

## OPERATION OF CONTROLS

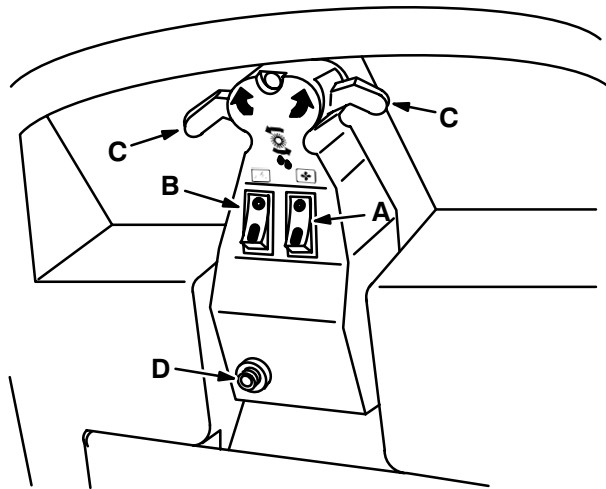

**CONTROL PANEL**

- A. Vacuum Fan Switch**
- B. Hand Tool Switch**
- C. Brush/Solution Lever(s)**
- D. Brush Circuit Breaker**

### VACUUM FAN SWITCH

Press the bottom (I) of the switch to turn on the vacuum fan. Press the top (O) of the switch to turn off the vacuum fan.

### HAND TOOL SWITCH

Press the bottom (I) of the switch to turn on the hand tool. Press the top (O) of the switch to turn off the hand tool.

### BRUSH/SOLUTION LEVER(S)

The machine has two levers situated under the machine handles at the top of the control panel. The brush/solution lever(s) turn on the scrub brush and the solution pump. One or both of the levers can be used to start the scrub brush and solution pump .

### BRUSH CIRCUIT BREAKER

The brush circuit breaker protects the brush motor from overload. If the brush pressure is too high, the brush circuit breaker will trip and the scrub brush will stop. To reset the brush circuit breaker, press the circuit breaker reset button on the circuit breaker. It may be necessary to allow the circuit breaker to cool down before resetting, or it may trip again. Reduce the brush pressure before resuming scrubbing and check the brush for obstructions.

## PRE-OPERATION

- Check power cord for any wear or damage. Do not operate machine with a damaged cord.
- Check if the correct power plug is installed.

## TRANSPORTING MACHINE

To move the machine from one place to another, tip the machine back by the machine handles and push the machine forward.

The power cord can be wrapped around the machine handles to keep it out of the way when moving the machine.

## HOW THE MACHINE WORKS

This machine is constructed to clean carpets. The head, which pre-soaks the carpet and lifts the dirt, contains solution dispensing nozzles . The vacuum picks up the solution into the recovery tank. The solution passes through the filtration system – debris and dirt are captured and the solution is clarified. Solution is forced into the solution tank from the recovery tank. Clarified cleaning solution – not diminished by the recycling process – is returned to spray the carpet.

## FILLING THE SOLUTION TANK

1. Unplug the machine and move the machine next to a water source.

**! WARNING: Hazardous voltage. Shock or electrocution can result. Unplug power cord before working on machine.**

2. Remove the solution tank cover, letting it hang on the side of the machine.
3. Using a clean bucket or hose, partially fill the tank with water through the fill opening.

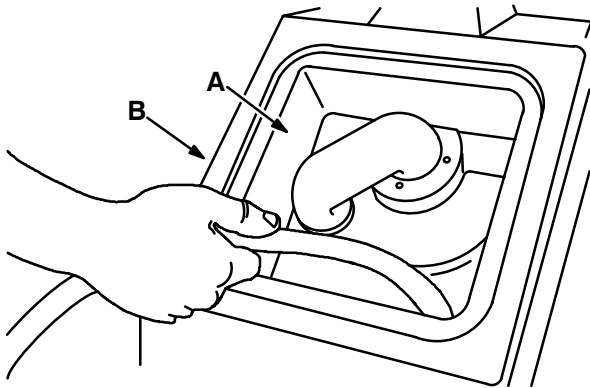

**FILLING THE SOLUTION TANK**

- A. Fill Opening
- B. Solution Tank

**ATTENTION: Do not use water hotter than 55° C (130° F) in the solution tank or tank damage may occur.**

4. Pour the specified amount of detergent into the solution tank. Use manufacturer recommended detergents for best results. Do not use more detergent than is recommended for the job. Powdered detergents are not recommended.

*Minimum Detergent Requirements:*

- Ph value 7-12 (dilution)
- Low foaming (less than 5 cm foam)
- Suitable for scrubbing machines
- Should not attack plastics and rubbers
- High resolving power in H<sub>2</sub>O

**! WARNING: Flammable materials can cause an explosion or fire. Do not use flammable materials in solution tank.**

5. Fill the solution tank with water to the desired level, but never higher than to the bottom link of the fill chain hanging inside the tank.

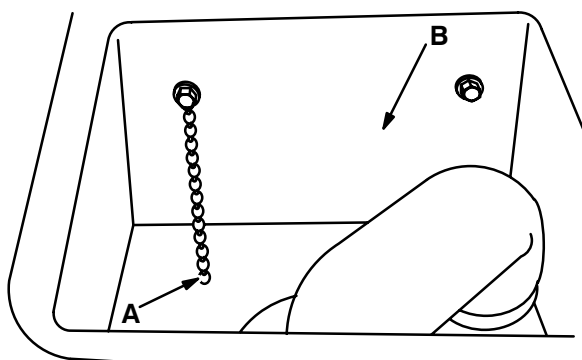

**FILL LEVEL OF SOLUTION TANK**

- A. Fill Chain
- B. Fill Opening

**NOTE:** If the floor to be cleaned already has puddles of standing water (such as swimming pool decks), **DO NOT COMPLETELY FILL** the solution tank. Picking up excess water will cause the solution tank to overflow and solution may enter and damage the vacuum motor.

6. Place the solution tank cover on the solution tank and make sure the cover gasket seals the tank.

**PREPARING FLOOR FOR CLEANING**

1. Remove loose objects or debris as they will plug squeegee openings and cause streaking and poor water pickup.
2. Remove gum or other such materials stuck to the floor with a putty knife or scraper.
3. Determine which cleaning mode is best for the floor condition, *standard* or *recycle*.

**SELECTING CLEANING MODE**

**(For Recycle Models Only)**

The recycle model can be used in either the standard or recycle cleaning mode.

**STANDARD CLEANING MODE**

Standard cleaning mode means that fresh solution is dispensed from the solution tank and used solution is picked up by the vacuum system and deposited in the recovery tank. When the recovery tank is full, it is emptied and the solution tank is refilled. This cleaning mode is recommended when carpeting is extremely soiled and requires restoration.

To select standard cleaning mode, remove the recovery tank cover and turn the recycle valve clockwise (OFF).

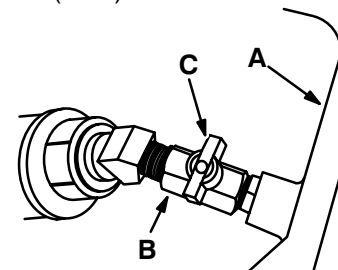

**RECYCLE VALVE SELECTOR HANDLE (OFF)**

- A. Recovery Tank
- B. Recycle Valve
- C. Recycle Valve Selector Handle

## OPERATION

### RECYCLE CLEANING MODE

Recycle cleaning mode means that cleaning solution is dispensed, recovered, and then prepared for reuse. This cleaning mode is recommended when carpeting is normally or lightly soiled. Use detergents which are suitable for recycling.

To select recycle cleaning mode, remove the recovery tank cover and turn the recycle valve counter-clockwise (ON).

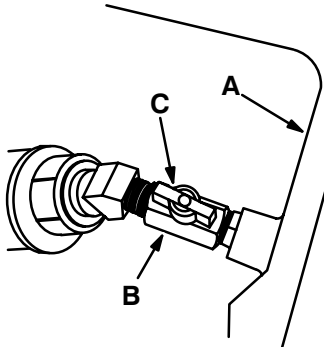

RECYCLE VALVE SELECTOR HANDLE (ON)

- A. Recovery Tank
- B. Recycle Valve
- C. Recycle Valve Selector Handle

### EXTENDED CLEANING IN THE RECYCLE MODE

If you have selected the recycle cleaning mode, you can extend the cleaning time of the machine by filling the recovery tank in addition to the solution tank as follows:

1. Fill the recovery tank to the last link of the fill level chain with solution.

**ATTENTION: Do not use water hotter than 55° C (130° F) in the recovery tank or tank damage may occur.**

2. Add detergent in the same dilution ratio used in the solution tank.
3. Make sure the machine is in the recycling mode.

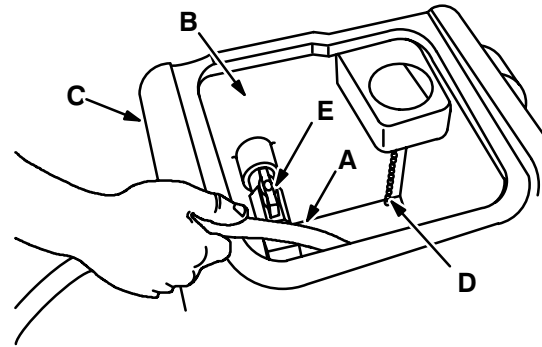

FILLING RECOVERY TANK

- A. Hose
- B. Fill Opening
- C. Recovery Tank
- D. Fill Chain
- E. Recycle Valve (ON)

4. Place the recovery tank cover back on the tank.

### CLEANING CARPETS

1. Push the machine to a place on the carpet you want to start.
2. Plug the power cord into a wall outlet.
3. Unlatch powerbrush head latch and lower head to the carpet.
4. Press the bottom (I) of the the vacuum fan switch to turn on the vacuum. Press the top (O) of the hand tool switch for normal cleaning.

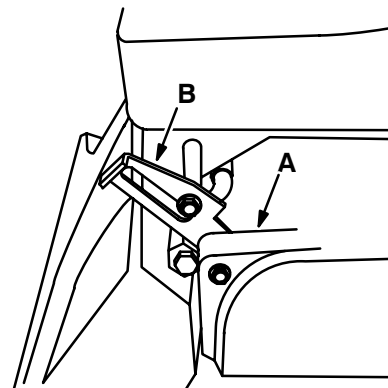

UNLATCH POWERBRUSH HEAD

- A. Powerbrush Head
- B. Latch

- Pull up one of the brush/solution levers as you pull the machine backward. Let go of the brush/solution lever(s) when you finish the cleaning path.

**NOTE:** After releasing the levers, continue pulling the machine, about 500 mm (20 in), to pick up all the solution.

**! WARNING: Flammable materials or reactive metals can cause an explosion or fire. Do not pick up flammable materials or reactive metals.**

- Tip the machine back by the machine handles. Push the machine forward to the beginning of the next cleaning path.
- Keep the cord out of the way of the machine while you are cleaning to prevent damage to the cord. Work away from the cord and wall outlets.

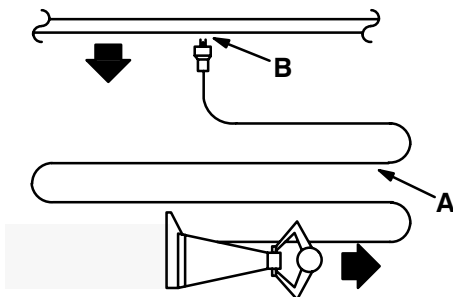

**SUGGESTED CLEANING PATH**

- A. Power Cord**
- B. Wall Outlet**

- It is very important to watch the foaming of the cleaning solution through the solution and recovery tank covers. Do not let the foam rise into the fill area of the solution tank. The foam will be drawn into the vacuum fan and can damage it.

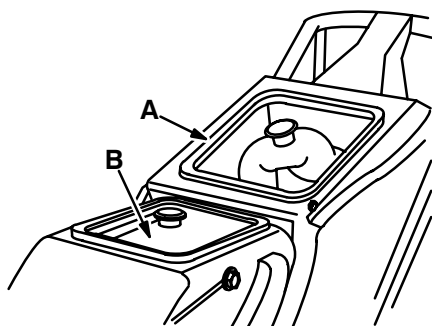

**FOAM IN FILL AREA**

- A. Solution Tank Cover**
- B. Fill Area**

If the foam starts rising into the fill areas, unplug the machine. Drain some of the solution from the tanks and/or reduce the amount of detergent being used. Chemical defoaming agents may be used. Follow instructions on the detergent.

**ATTENTION: Excessive use of defoamers in the recycle mode may reduce cleaning power of the detergent.**

## EMPTYING AND CLEANING THE SOLUTION TANK

- Unplug the machine and place the machine next to a floor drain.

**! WARNING: Hazardous voltage. Shock or electrocution can result. Unplug power cord before working on machine.**

- Unhook the drain hose from the retaining clip on the back of the machine.
- Loosen the drain plug by turning the drain plug knob counter-clockwise.
- Remove the drain plug while holding the hose up. Quickly lower the hose to the floor drain, as the solution rushes out of the drain hose. Flow rate can be reduced by squeezing the hose.

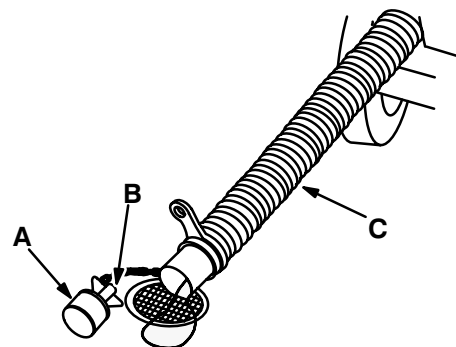

**DRAINING THE SOLUTION TANK**

- A. Drain Plug**
- B. Drain Plug Knob**
- C. Drain Hose**

- Flush out the inside of the solution tank with clean water.

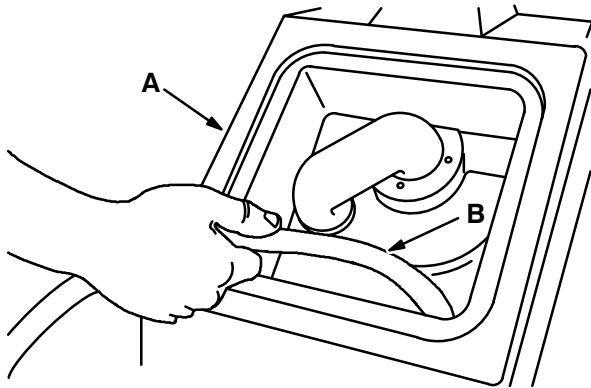

**FLUSHING SOLUTION TANK**

- A. Solution Tank
- B. Hose

6. Wipe off the vacuum inlet screen at the top of the solution tank.

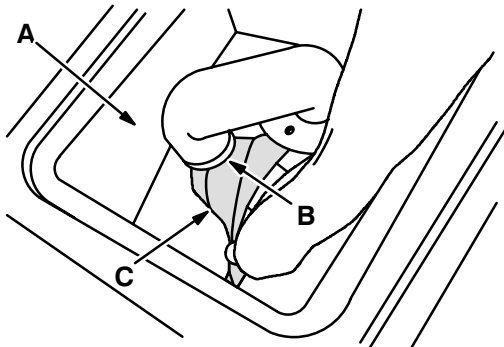

**VACUUM INLET SCREEN**

- A. Fill Area
- B. Vacuum Inlet Screen
- C. Cloth

7. Make sure to clean the screen filter at the bottom of the tank. Put the solution screen back in the tank.

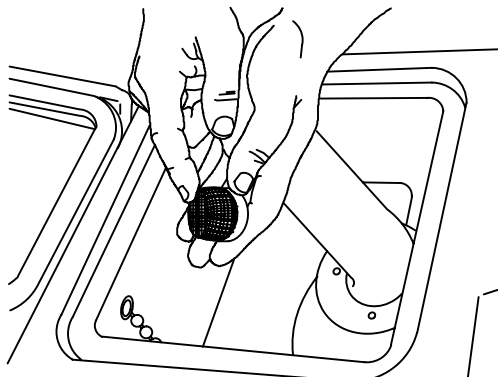

**SOLUTION SCREEN**

8. When the solution tank is completely drained and flushed, place the drain plug back into the

end of the drain hose and turn the end of the drain plug clockwise to tighten the plug. Hang the drain hose back onto the retaining clip on the back of the machine.

## EMPTYING AND CLEANING THE RECOVERY TANK

1. Turn the recycle valve clockwise horizontally across the solution hose in the recovery tank (*recycle model only*). Pull the vacuum hose off the recovery tank.

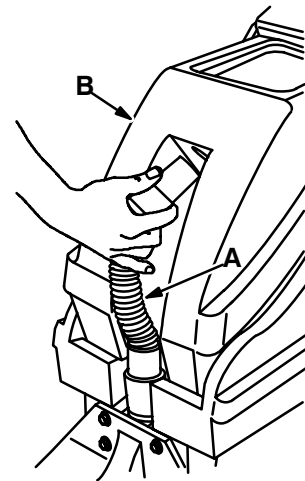

**VACUUM HOSE**

- A. Vacuum Hose
- B. Recovery Tank

2. Lift the recovery tank out of the machine with the handle.

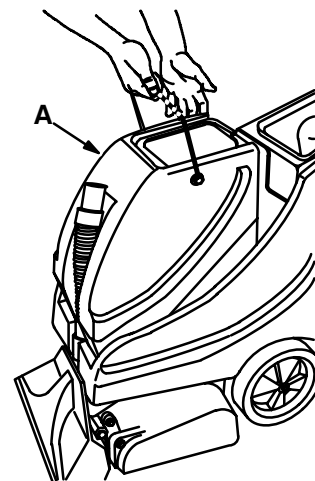

**REMOVING RECOVERY TANK**

- A. Recovery Tank

3. Dump the solution out the recovery tank. Rinse out the recovery tank and cover baffle with clean hot water. Rinse screen filter mounted on the recycle valve with clean hot water (*recycle model only*).

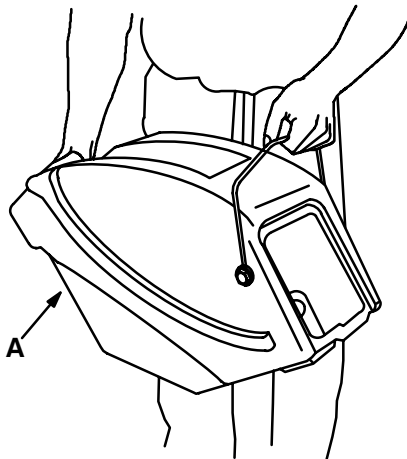

**EMPTYING RECOVERY TANK**

**A. Recovery Tank**

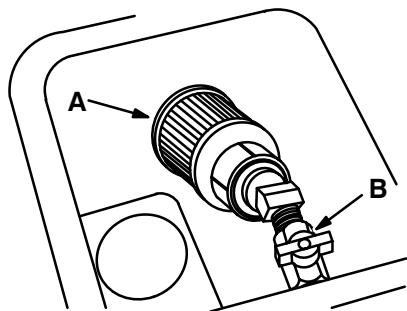

**SCREEN FILTER (recycle model)**

**A. Screen Filter  
B. Recycle Valve**

4. Place the recovery tank back into the machine. Reconnect the vacuum hose to the recovery tank. Make sure that the tank gaskets are seated properly.

**POST-OPERATION**

Check this list of items over after operating the machine:

- Check the power cord for damage and wear. Wipe cord clean and wrap around handle of machine.
- Check for and remove any string or material wrapped around the scrub brush.
- Move the machine to an area to be kept until it is needed again. It is suggested that both tank covers be left slightly open for the tanks to ventilate.
- Lock the powerbrush head in the UP position to prevent the brush taking a "set". Lift the powerbrush head from the floor and slide the latch until it catches.

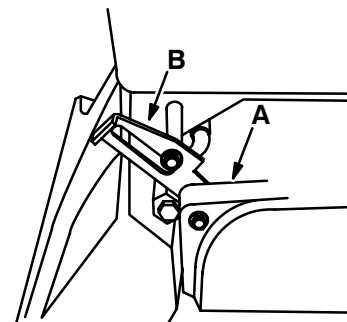

**LOCKING UP POWERBRUSH HEAD**

**A. Powerbrush Head  
B. Latch**

- Protect the machine from freezing when if it will be stored or transported in areas where solution in the system may freeze and damage the components.

## OPERATION

### OPTIONAL ATTACHMENT TOOLS

**NOTE:** For all attachments the vacuum and solution hose is connected in the same way.

1. Attach male end of solution feed hose to the female quick-disconnect on the machine. Push the male connector in until it stops. Pull on the hose to make sure it is connected.

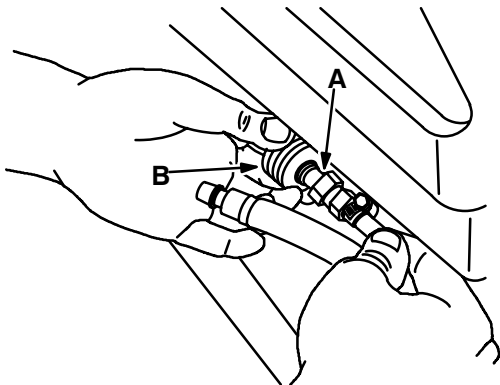

#### CONNECTING SOLUTION FEED HOSE

- A. Male Quick-Disconnect
- B. Female Quick-Disconnect

2. Pull the vacuum hose off the recovery tank, and firmly insert the hose cuff from the wand attachment hose into the tank.

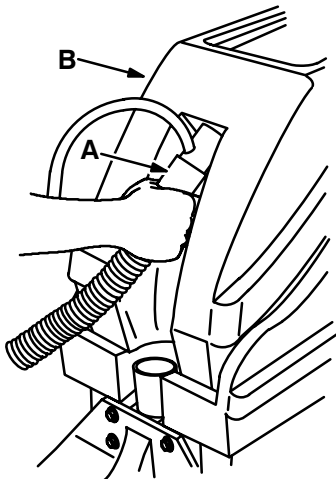

#### CONNECTING ATTACHMENT HOSE

- A. Wand Attachment Hose
- B. Recovery Tank

3. Attach the other ends of the solution and vacuum hoses to the selected attachment tool in the same way.

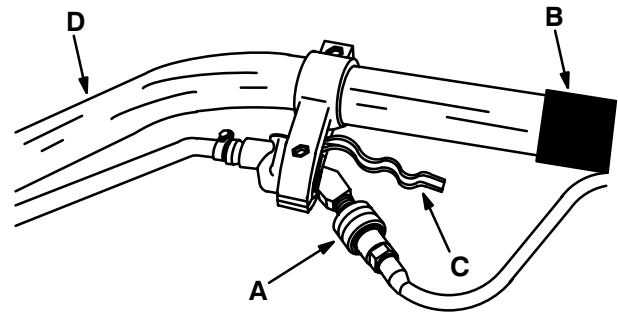

06598

#### CONNECTING ATTACHMENT

- A. Solution Hose Quick-Disconnect
- B. Vacuum Hose
- C. Valve Handle
- D. Selected Attachment

4. Press the bottom (I) of the hand tool switch. Press the bottom (I) of the vacuum switch.
5. To disconnect the attachment, reverse the above steps.

### OPERATION OF ATTACHMENTS

The attachments only work properly by pulling them toward you, not pushing. Set the vacuum end of the tool on the surface to be cleaned and squeeze the valve lever. Immediately begin pulling the tool toward you, spraying the surface with detergent and immediately vacuuming up the solution.

#### CARPET WAND

The carpet wand can be used for more inaccessible places.





**UPHOLSTERY/STAIR TOOL**

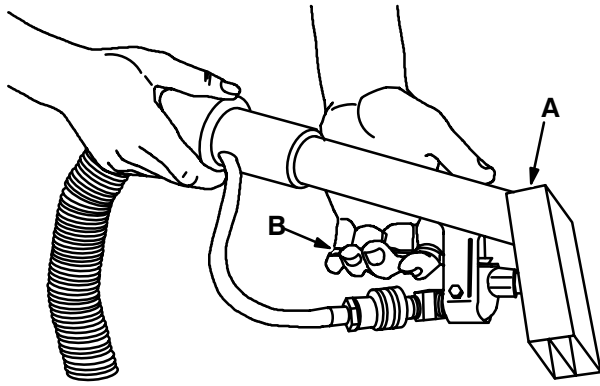

**UPHOLSTERY/STAIR TOOL**

- A. Upholstery Tool**
- B. Valve Handle**

**HARD FLOOR WAND**

To scrub with the hard floor wand, flip the cleaning tool so the brush is facing down.

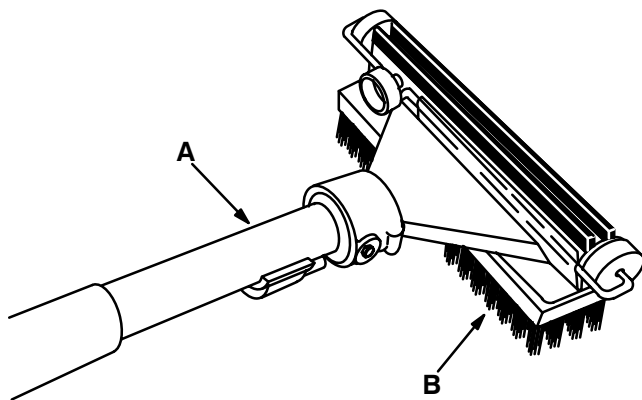

**HARD FLOOR WAND**

- A. Cleaning Tool**
- B. Brush**

To vacuum up the solution with the hard floor wand, flip the cleaning tool so the squeegee side is facing down. Push and/or pull the tool across the floor to pickup the solution.

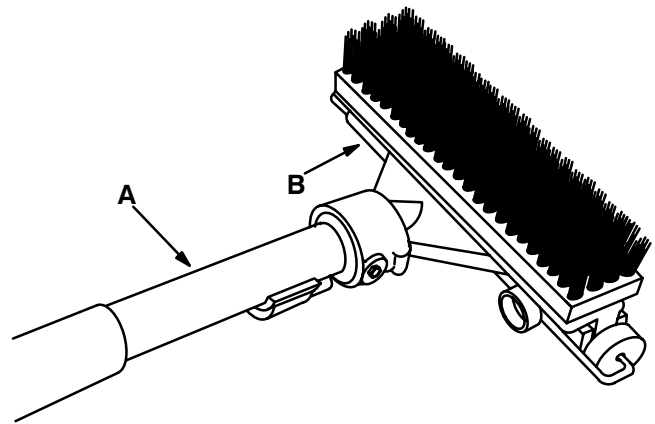

**HARD FLOOR WAND**

- A. Cleaning Tool**
- B. Squeegee**

If the hard floor wand is difficult to push or does not pickup the solution properly, adjust the roller wheels on the tool by turning the black adjustment knob.

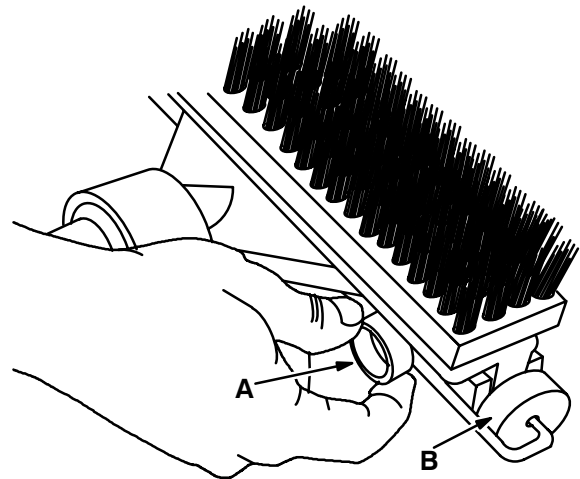

**ADJUSTING ROLLER WHEELS**

- A. Adjustment Knob**
- B. Roller Wheels**

The wheels are properly adjusted when the squeegee blades deflect slightly while the tool is pushed back and forth.

## MAINTENANCE REQUIREMENTS

The *DAILY*, *WEEKLY*, and *MONTHLY* maintenance requirements listed here may be performed without tools by the machine operators. Instructions for these maintenance requirements are provided in this section of the manual.

The *EVERY SIX MONTHS* maintenance requirements should only be performed by a qualified mechanic.

### DAILY

Perform all duties listed under PRE-OPERATION and POST-OPERATION Sections

If machine is to be transported or stored under freezing conditions, machine (and any options) must be freeze protected. See *FREEZE PROTECTION*.

### WEEKLY

Remove and flush out the solution dispensing nozzles in the intake head and powerbrush head.

Clean and flush out the vacuum intake nozzle in the intake head at the front of the machine.

### MONTHLY

Flush the solution system of alkaline residue with diluted vinegar solution. See *RINSING SOLUTION SYSTEM* under *SOLUTION SYSTEM*.

Lubricate brush housing pivot pins/bearings with light oil.

Check and tighten all fasteners/hardware.

### EVERY SIX MONTHS

Six month and yearly maintenance is recommended to be performed by a service mechanic from your authorized Service Center. Six month maintenance includes weekly and monthly maintenance, plus:

- Drive belt inspection/replacement.
- Scrub brush replacement (if required). Replace the brush when the remaining

bristles measure 10 mm (0.38 in) or less in length.

- Motor carbon brush inspection/replacement in brush, vacuum motors.
- Brush bearing and seal inspection/replacement.

## SOLUTION SYSTEM

The solution system can accumulate an alkaline buildup. The pumping/nozzle system should be flushed monthly, or more often if hard water is used.

### RINSING SOLUTION SYSTEM

1. Mix a solution of 1 L (0.26 gal) white vinegar to 8 L (2.1 gal) water.
2. Pour the solution into the solution tank. Position the machine over a floor drain.
3. Plug in the power cord and press the bottom (I) of the hand tool switch. The pump will start and spray through the nozzles to the floor.
4. Run the pump until all solution has been dispensed through system.
5. Rinse the solution system again with 8 L of water only. Check the solution dispensing nozzles for plugging.

## SOLUTION DISPENSING NOZZLES AND VACUUM INLET

The intake head contains four solution dispensing nozzles. There is also one dispensing nozzle contained in the powerbrush head. Remove and rinse these nozzles every week, or if they are plugged. Remove any debris caught in the vacuum inlet and flush with water.

**ATTENTION: Plugged nozzle(s) can cause streaking of carpets, and create a back-pressure that can damage the solution pump. Always remove and clean nozzles as soon as plugging occurs.**

### To clean nozzles and vacuum inlet:

1. Unplug the power cord from the wall outlet.

**! WARNING: Hazardous voltage. Shock or electrocution can result. Unplug power cord before working on machine.**

2. Empty the solution and recovery tanks.
3. Tip the machine back, or on its side.

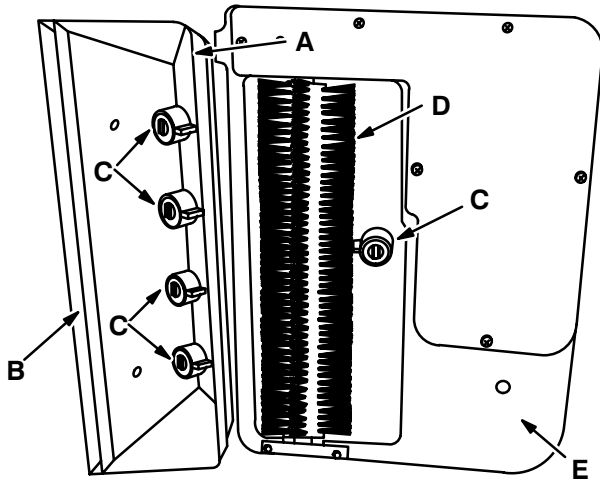

**SOLUTION DISPENSING NOZZLES**

- A. Intake Head**
- B. Vacuum Inlet**
- C. Nozzles**
- D. Scrub Brush**
- E. Powerbrush Head**

4. Turn the dispensing nozzle to the left to remove it from the outlet port. Rinse the nozzle under water. Be careful not to lose the rubber gasket mounted inside the nozzle.

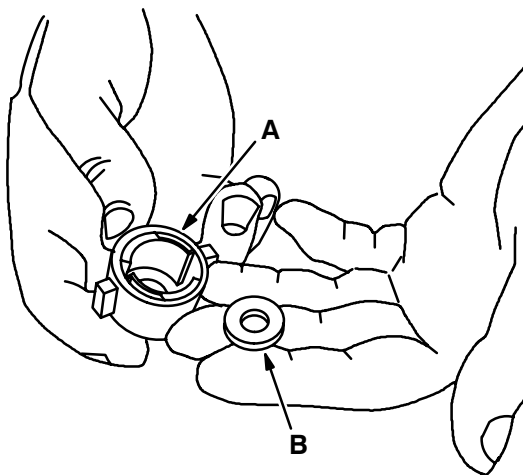

**DISPENSING NOZZLE**

- A. Nozzle**
- B. Gasket**

5. Place the dispensing nozzle back on the outlet port and turn the nozzle to the right to tighten it. Remove any debris caught in the vacuum inlet and flush with water.

**FREEZE PROTECTION**

Freeze protection of the machine is necessary to prevent damage to components of the solution system if the machine is going to be exposed to freezing temperatures.

**ATTENTION: Freezing temperatures can severely damage components. Do not store or transport machine in areas where freezing of solution contents could occur, unless machine is freeze protected. Failure of components due to lack of freeze protection voids the warranty on such components.**

**To protect machine from freezing:**

1. Move machine over floor drain and plug the power cord into an outlet. Drain both tanks.
2. Pour 2 L (0.53 gal) of pre-mixed automotive-type windshield washer solution into solution tank.

**ATTENTION: Do not use cooling system anti-freeze such as ethylene glycol.**

3. Press the bottom (I) of the hand tool switch. The pump will start and spray through the nozzles to the floor. Run the pump until all solution has been dispensed through system.

**ATTENTION: Machines and attachments that have been freeze protected must be flushed completely prior to normal use. Follow directions for the appropriate cleaning process, but run your selected cleaning solution through the system to purge all anti-freeze before starting the cleaning process.**

# MAINTENANCE

## TROUBLESHOOTING

PROBLEM	CAUSE	SOLUTION
Machine does not operate	Power cord not plugged in	Plug in to proper circuit
	Building circuit breaker tripped	Reset breaker
	Electrical malfunction	Contact service center
Brush does not run	Circuit breaker is tripped	Reset circuit breaker
	Brush belt broken	Replace belt
	Electrical malfunction	Call service center
Brush runs but does not scrub carpet	Powerbrush head locked up	Release powerbrush head latch
	Brush bristles worn	Replace brush
Vacuum motor does not run	Vacuum switch in OFF position	Turn to ON
	Electrical malfunction	Call service center
Pump does not dispense solution (triggers/valve operated)	Tank low or empty	Refill tank(s)
	Nozzle feed hose or accessory hose not connected to quick disconnect	Connect properly
	Pump inlet filter clogged	Clean filter
	Nozzles and/or feed lines plugged	Clean
	Pump or electrical malfunction	Contact service center
Solution flow does not stop when triggers are released	Hand tool switch is set in the WAND position	Set hand tool switch to TOP position
Machine leaves streaks on carpet	Solution low or empty	Refill tank(s)
	Nozzle(s) and solution tank screen plugged	Clean
	Operation too fast on dirty carpet	Slow down cleaning speed
	Improper chemical or mixture	Use proper chemical and dilution
	(in recycle mode) Solution contaminated	Rinse and refill
Carpet too wet – machine does not recover enough water solution	Hose loose at vacuum head or tank	Install hose tightly
	Tank cover(s) improperly installed	Reposition
	Tank cover gaskets leak	Inspect/replace
	Recovery tank not seated properly against solution tank gaskets	Reposition tank properly
	Operation too fast on dirty carpet	Slow down cleaning process
	Could be normal – different carpets release solution differently	Test on different carpet

<b>PROBLEM</b>	<b>CAUSE</b>	<b>SOLUTION</b>
Foam in recovery tank overflows	Recovery tank overfilled	Empty recovery tank
	Too much or wrong chemical	Reduce dilution/change to proper chemical
	Soap residue in carpet from previous cleanings	Reduce chemical dilution or rinse carpet with clean water first. Consider using chemical defoamer in recovery system
	System overfilled (recycle mode)	Reduce solution level
Foam exits vacuum motor cover at rear of machine	System overfilled	Reduce solution level
	Too much or wrong chemical	Reduce dilution/change to proper chemical
Solution leaks from machine	Loose clamps/fittings	Tighten/replace
	Broken hoses/components	Inspect/repair/replace
	Components damaged from freezing. Follow freeze protection procedures in future	Inspect/repair/replace

**Main Frame and Plumbing Group**

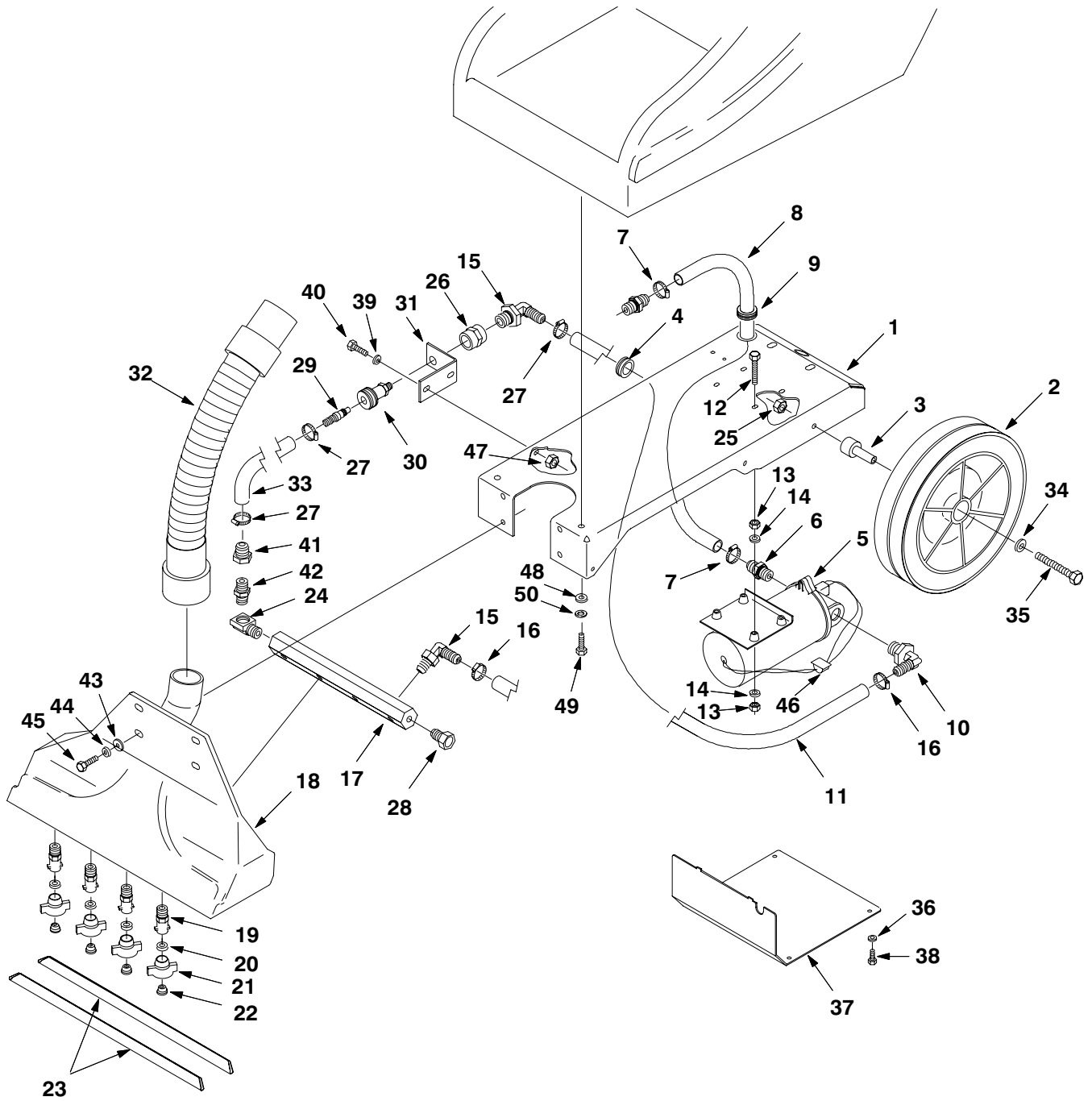

## Main Frame and Plumbing Group

Ref	Part No.	Description	Qty.
1	575718	Frame	1
2	575234000	Wheel	2
3	575252000	Axle Spacer	2
4	575417	Grommet	1
5	180103	Pump, Solution 120V	1
5	180109	Pump, Solution 230V	1
6	150538	Hose Barb	1
7	140310	Clamp, Hose	2
8	25160	Hose, Braided	1
9	575505000	Grommet	1
10	575036	Fitting, Elbow	1
11	575416	Hose, Black	1
12	575323000	Screw, m05x30	4
13	140283	Nut, Lock m05	8
14	200315016	Washer, Flat	8
15	575038	Fitting, Elbow	2
16	140305	Clamp, Hose	2
17	575278000	Manifold	1
18	575236000	Shoe, Water Pickup	1
19	575281000	Body, QuickJet	5
20	575276000	Gasket, QuickJet	5
21	575282000	Cap, QuickJet	4
22	200960	Nozzle, Spray	4
23	575239000	Glide, Vac Shoe	2
24	150420	Elbow, Street	1
25	200160017	Nut, Lock	2
26	150300	Connector, Anchor	1
27	140301	Clamp, Hose	3
28	575318000	Plug, Pipe	1
29	575521000	Fitting, Quick Conn	1
30	575520000	Quick Connect	1
31	575265000	Angle, Coupling	1
32	575235000	Hose, Vacuum	1
33	25160	Hose, Braided	1
34	200313012	Washer, Flat	4
35	575544000	Screw, m8x80mm	2
36	140018	Washer, Lock	2
37	575719	Cover	1
38	039706105	Screw, S-tap #10	2
39	140012	Washer, Plain	2
40	200031436	Screw, m06x16mm	2
41	575522000	Fitting, 3/8Fx3/8H	1
42	575217000	Valve, Check	1
43	200313012	Washer, Flat	4
44	575533000	Washer, Lock	4
45	200607491	Screw, m08x25mm	4
46	575037	Clip, Wire	1
47	579028	Nut, Lock	1
48	14880.5	Washer, Flat	4
49	200031486	Screw, m08x16mm	4
50	200370019	Washer, Lock	4

Recovery Tank Group

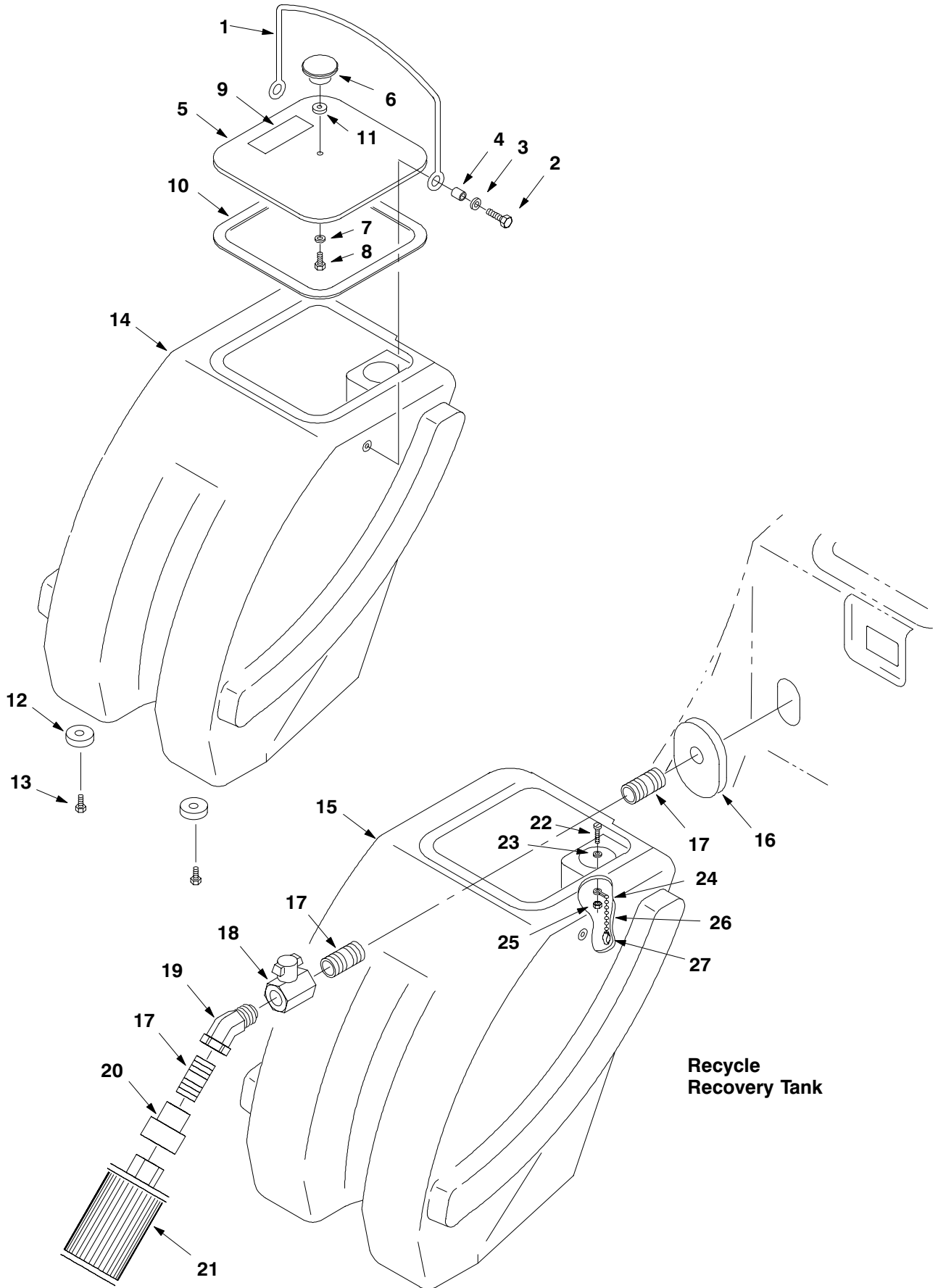



## Recovery Tank Group

Ref	Part No.	Description	Qty.
1	575220000	Handle, Tank	1
2	575029000	Screw,m8x20mm	2
3	200313012	Washer, Flat	2
4	575524000	Washer, Nylon	2
∇ 5	575223000	Cover, Rec. Tank	1
▲ 6	578032000	Knob, Fill Cover	1
▲ 7	25183.4	Washer, Flat	1
▲ 8	578235000	Screw, .25–20x.75	1
▲ 9	575105	Label, Recycle	1
▲ 10	575224000	Gasket, Cover	1
▲ 11	575600	Washer, Rubber	1
12	575531	Spacer	2
13	575569000	Screw	2
14	N/A	Tank, Recovery Pail (non–recycle model)	1
∇ 15		Asm., Recovery Tank, Pail, Teal (recycle model)	1
	609163	Tank, Recovery, Pail, Teal (recycle model)	1
▲ 16	575228000	Seal, Water	1
▲ 17	575535000	Fitting, Nipple	3
▲ 18	575340000	Valve, Ball	1
▲ 19	150404	Street, Elbow, 45°	1
▲ 20	575545000	Fitting, Reducer	1
▲ 21	578014000	Screen	1
22	200613384	Screw, m5x14mm	1
23	575541000	Washer, Flat	1
24	575536	Coupling, End	1
25	575540000	Nut, Jam	1
26	575537	Chain, Ball	1
27	575538000	Link, Spacing	1

**Solution Tank Group**

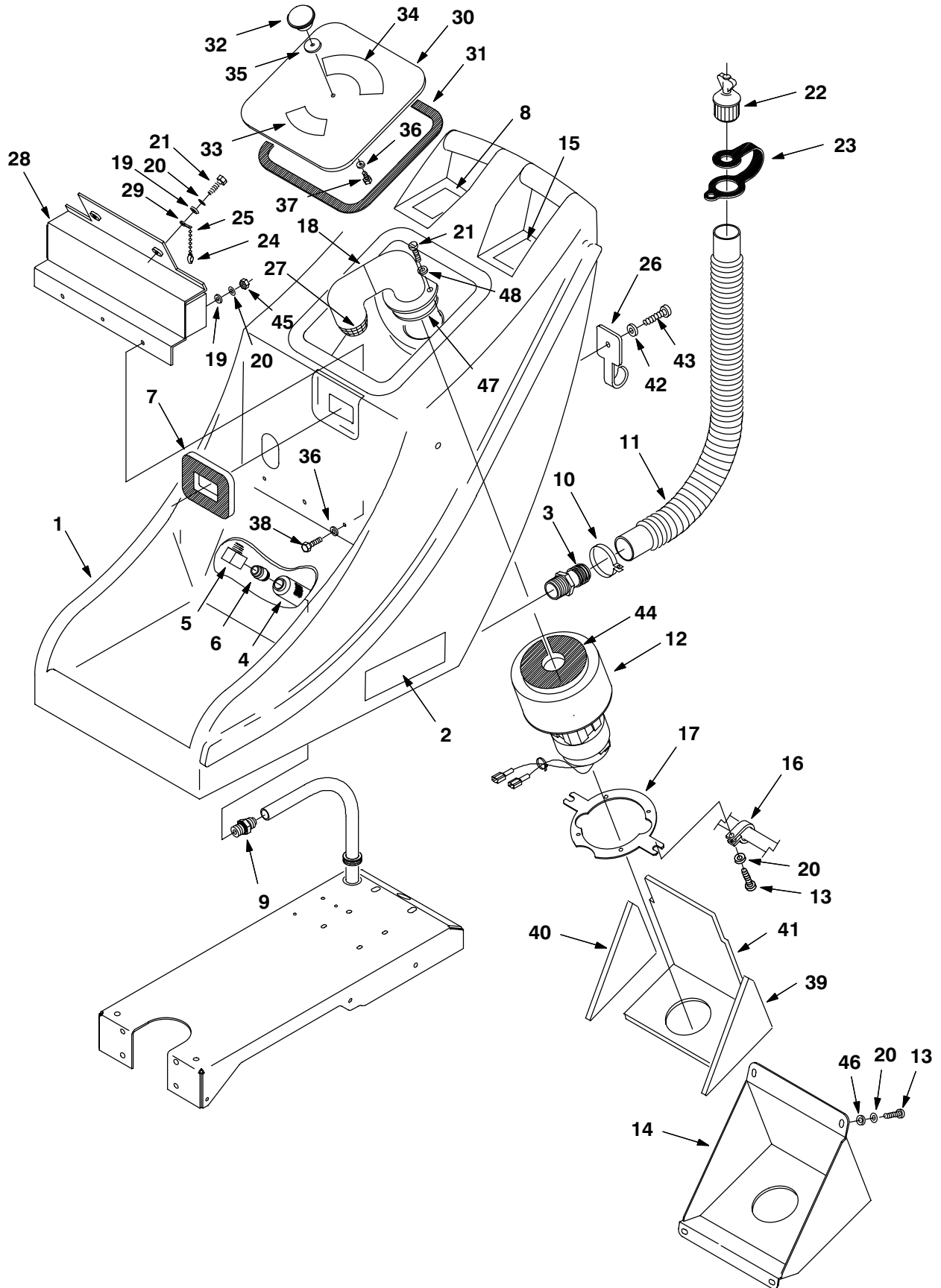

## Solution Tank Group

Ref	Part No.	Description	Qty.	
1	575210000	Tank, Solution, Teal (recycle model)	1	
2	609072	Decal, "1230"	2	
3	621277000	Fitting, Straight	1	
4	575055	Filter, Pump	1	
5	150420	Fitting, 90°	1	
6	150617	Fitting, Nipple	1	
7	575250000	Gasket, Tank	1	
8	578729	Decal, Read Manual	1	
9	150538	Adaptor	2	
10	140308	Clamp, Hose	1	
11	578031000	Hose, Drain	1	
12	575243000	Motor, Vacuum 120V	1	
	575034	Motor, Vacuum 230V/240V	1	
13	578321000	Screw, 6mx16mm	6	
14	575245000	Cover, Vacuum Motor	1	
15	575345000	Decal, After Use	1	
16	575329000	Clamp, Wire	1	
17	575701	Bracket, Vac Motor	1	
18	575411000	Elbow, Inlet	1	
19	059650283	Washer, Flat	6	
20	200662017	Washer, Lock	11	
21	578302	Screw, m5x14mm	2	
22	621324	Plug, Expansion	1	
23	578441	Strap, Hose Drain	1	
24	575538000	Spacing Link	1	
25	575537	Chain, Ball	1	
26	575502000	Clip, Hose Drain	1	
27	575246000	Screen, Inlet	1	
28	575511000	Baffle, Tank	1	
29	575536	Couolina. End	1	
▼	575598	Cover, Assembly	1	
▲	30	575221000	Cover, Tank	1
▲	31	604322	Gasket, Cover	1
▲	32	578032000	Knob, Fill Cover	1
▲	33	575104	Decal, Fill Tank (textless)	1
▲	34	578767	Decal, 'Flam. Mat.'	1
▲	35	575600	Washer, Rubber	1
▲	36	25183.4	Washer, Sealing	4
▲	37	573268	Screw, .25-20x.75	1
38	200609438	Screw, m6x20mm	3	
39	575247000	Foam, Sound	1	
40	575248000	Foam, Sound	1	
41	575249000	Foam, Sound	1	
42	200315016	Washer, Flat	1	
43	200051384	Screw, m5x14mm	1	
44	100038	Gasket	1	
45	200634016	Nut	3	
46	579210	Washer, Flat 6.4mm	4	
47	575561000	O Ring	1	
48	575541000	Washer, Flat	1	

▼ Assembly

▲ Included in Assembly

Solution Tank Group – EMC Model

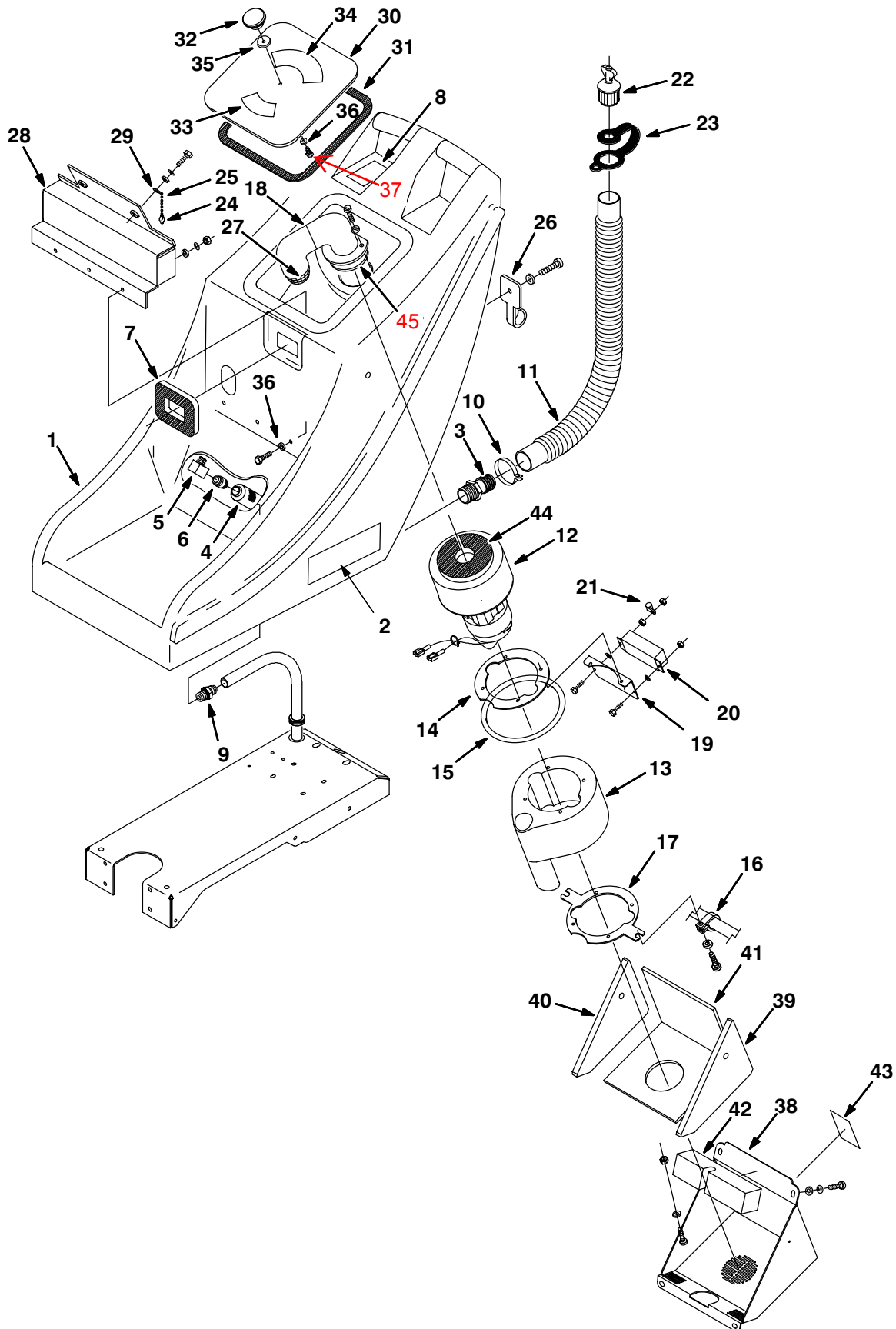

## Solution Tank Group – EMC Model

Ref	Part No.	Description	Qty.
1	575210000	Tank, Solution, Teal (recycle model)	1
2	609072	Decal, "1230"	1
3	621277000	Fitting, Straight	1
4	575055	Filter, Pump	1
5	150420	Fitting, 90°	1
6	150617	Fitting, Nipple	1
7	575250000	Gasket, Tank	1
8	578729	Decal, Read Manual	1
9	150538	Adaptor	2
10	140308	Clamp, Hose	1
11	578031000	Hose, Drain	1
12	575034	Motor, Vacuum 240V	1
13	575700	Shroud	1
14	575707	Gasket	1
15	575706	Gasket	1
16	575329000	Clamp, Wire	1
17	575701	Bracket, Vac Motor	1
18	575411000	Elbow, Inlet	1
19	578865	Bracket	1
20	578869	Filter, RFI	3
21	578849	Clamp	1
22	621324	Plug, Expansion	1
23	578441	Strap, Hose Drain	1
24	575538000	Spacing Link	1
25	575537	Chain, Ball	105
26	575502000	Clip, Hose Drain	1
27	575246000	Screen, Inlet	1
28	575511000	Baffle, Tank	1
29	575536	Coupling, End	1
▼	575598	Cover, Assembly	1
▲	30 575221000	Cover, Tank	1
▲	31 604322	Gasket, Cover	1
▲	32 578032000	Knob, Fill Cover	1
▲	33 575104	Decal, "Fill"	1
▲	34 578767	Decal, 'Flam. Mat.'	1
▲	35 575600	Washer, Rubber	1
▲	36 25183.4	Washer, Sealing	1
▲	37 573268	Screw, .25-20x.75	1
▽	38 575705	Cover Assy., Vac	1
▲	39 575721	Foam, Sound	1
▲	40 575722	Foam, Sound	1
▲	41 575723	Foam, Sound	1
▲	42 575724	Foam, Sound	1
▲	43 578768	Decal, Hazard Volt.	1
▲	44 100038	Gasket	1
45	575561000	O Ring	1

▽ Assembly

▲ Included in Assembly

**Powerbrush Group**

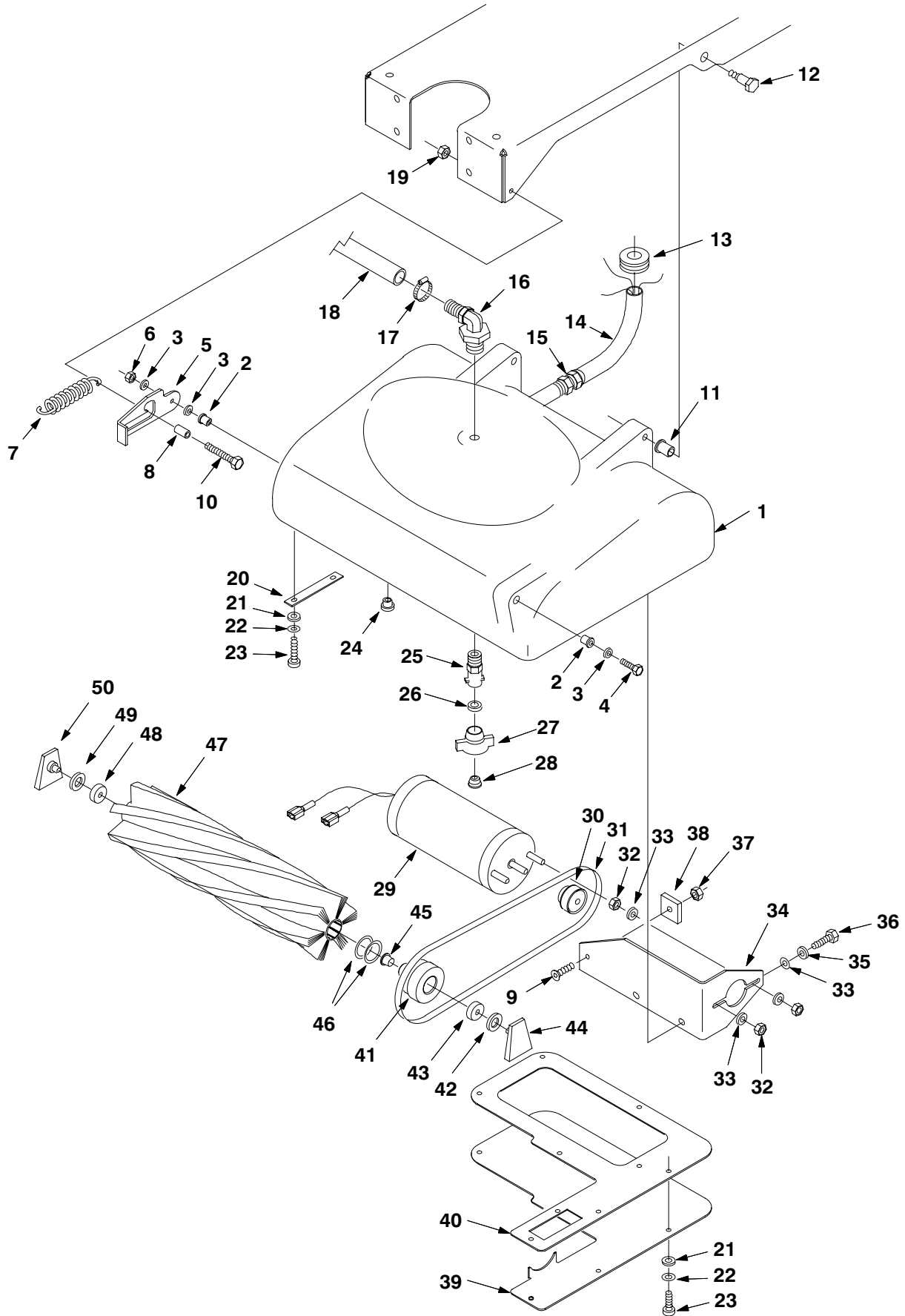

## Powerbrush Group

Ref	Part No.	Description	Qty.
▽ 1	609167	Housing, Brush, Teal	1
▲ 2	575542000	Bearing, Flange	2
3	200304017	Washer, Flat	2
4	575543000	Screw, M06-45	1
5	575314000	Angle, Head Lift	1
6	579028	Nut, Lock	2
7	575570	Spring, Extension	1
8	575316000	Spacer	1
9	069764140	Screw, M05-16mm	1
10	575546000	Screw, .31-18x2.25"	1
11	630095	Bearing, Flange	2
12	630470	Screw, Shoulder	2
13	21497	Strain Relief	1
14	575304000	Harness, Wire	1
15	21497	Strain Relief	2
16	575038	Fitting, Elbow	1
17	140305	Clamp, Hose	1
18	575341000	Hose, Black	1
19	140546	Nut, Lock	1
20	575268000	Retainer, Strap	1
21	200785014	Washer, Flat	10
22	575539000	Washer, Lock	10
23	200630342	Screw, M04x10mm	10
24	575530000	Cap, Plug	1
25	575281000	Body, QuickJet	1
26	575276000	Gasket, QuickJet	1
27	575571000	Cap, QuickJet	1
28	575568000	Tip, QuickJet	1
29	575254000	Motor, Brush Assy 120v	1
	575375000	Brush Card Assembly Replacement, 120v (not shown)	Set/2
	575373	Armature with Bearings, 120v (not shown)	1
29	575581	Motor, Brush Assy 230v	1
	190154	Brush Card Assembly Replacement, 230v (not shown)	Set/2
30	575259000	Sheave, Motor	1
31	575261000	Belt	1
32	575380	Nut, #10-32	4
33	140012	Washer, Plain	6
34	575256000	Angle, Motor Mount	1
35	069777319	Washer, Lock	2
36	200031433	Screw, M06x12mm	2
37	575540000	Nut, Lock	1
38	130780	Bridge Rectifier	1
▽ 39	575272000	Plate, Base Assy	1
▲ 40	575273000	Gasket, Floor Plate	1
▽ 41	575260000	Pulley, Brush Assy	1
▲ 42	575266000	Seal, Brush	1
▲ 43	140125	Bearing, Brush	1
▲ 44	575264000	Mount, Bearing	1
▲ 45	575269000	Cap, Plug	1
46	575267000	Washer, Wavy	2
▽ 47	575387000	Brush Assembly	1
▲	575262000	Brush Only	1
▲ 48	140125	Bearing, Brush	1
▲ 49	575266000	Seal, Brush	1
▲ 50	575264000	Mount, Bearing	1
<b>Optional Brush</b>			
	578322	Brush, Grit, 17" Optional (not shown)	1

▽ Assembly

▲ Included in Assembly

**Electrical Panel Group**

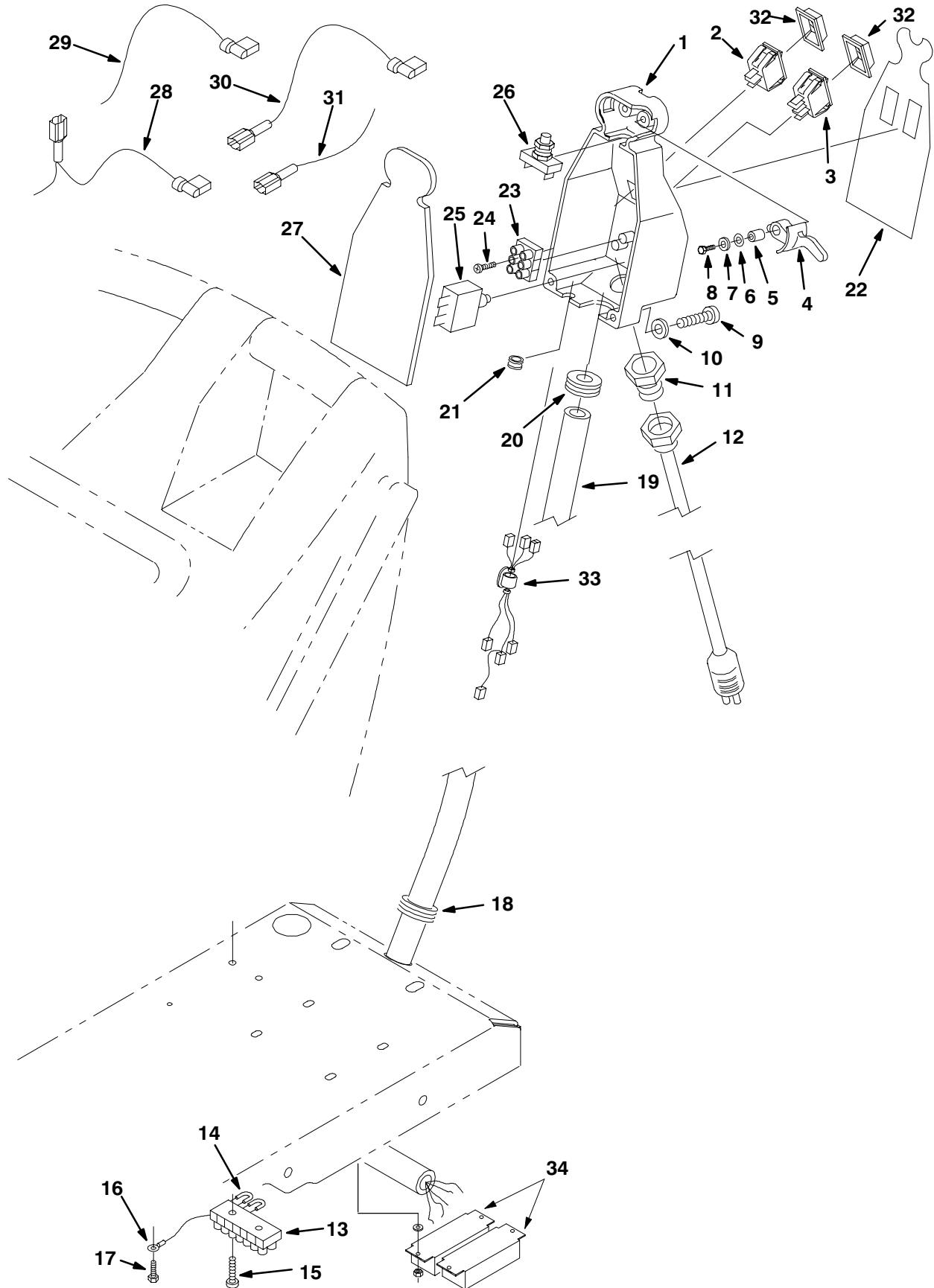



## Electrical Panel Group

Ref	Part No.	Description	Qty.
1	575577	Cover Console	1
2	575300000	Switch, Rocker	1
	578719	Switch, Rocker (EMC Model)	1
3	578005000	Switch, Rocker	1
	575750	Switch, Rocker (EMC Model)	1
4	578002000	Arm Trigger	2
5	578082000	Spacer, Trigger	2
6	578186000	Washer, Flat	2
7	200662012	Washer, Lock	2
8	069764190	Screw, M03x16	2
9	578008000	Screw, M5x31.3	3
10	140018	Washer, Lock	3
11	130167	Strain Relief, Pigtail	1
12	578023000	Cord Set	1
13	578013000	Block, Terminal	1
14	578259000	Wire, Jumper	2
15	578011000	Screw, Self Tap	2
16	575513000	Ground Wire Assy	1
17	140897	Screw, F, Slot	1
18	579124	Strain Relief	1
19	575303000	Harness, Wire	1
20	578009000	Grommet	1
21	578080000	Grommet	1
22	575101	Decal, Console	1
23	578007000	Block, Terminal	1
24	578011000	Screw, Self Tap	2
25	578004000	Circuit Breaker, 3A, 120V	1
25	578337000	Circuit Breaker, 1.5A, 230V	1
26	130712	Switch, Pushbutton	1
27	575576000	Gasket	1
28	575305000	Wire Assy, Console	1
29	575306000	Wire Assy, Acc Sw	1
30	575308000	Wire Assy, Vac Sw	1
31	575309000	Wire Assy, Vac Mtr	1
32	578720	Splash Guard (EMC Model)	2
33	575712	Wire Assy (EMC Model)	1
34	578869	Filter, RFI (EMC Model)	1

Electrical Schematic

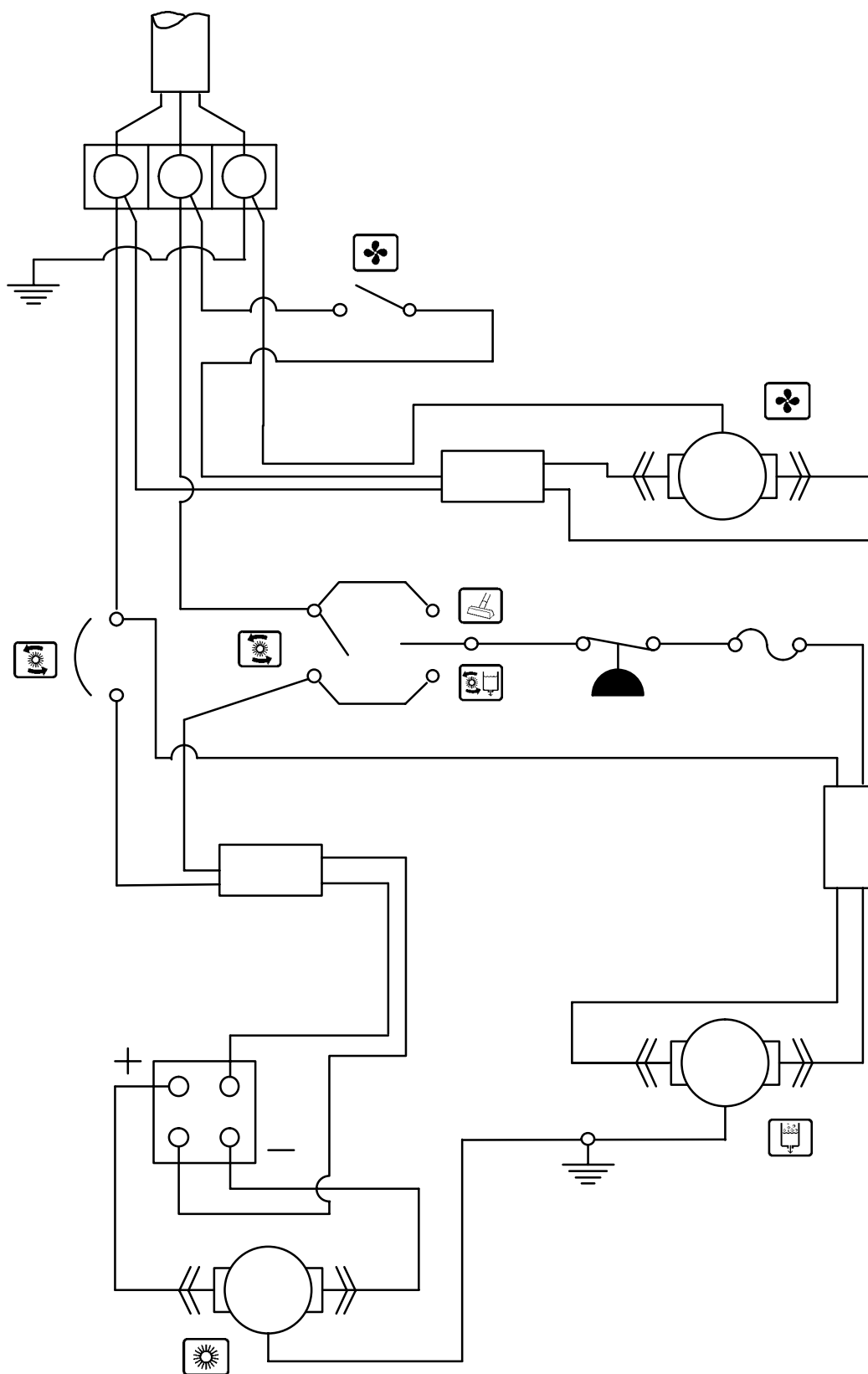

**Pump Motor**

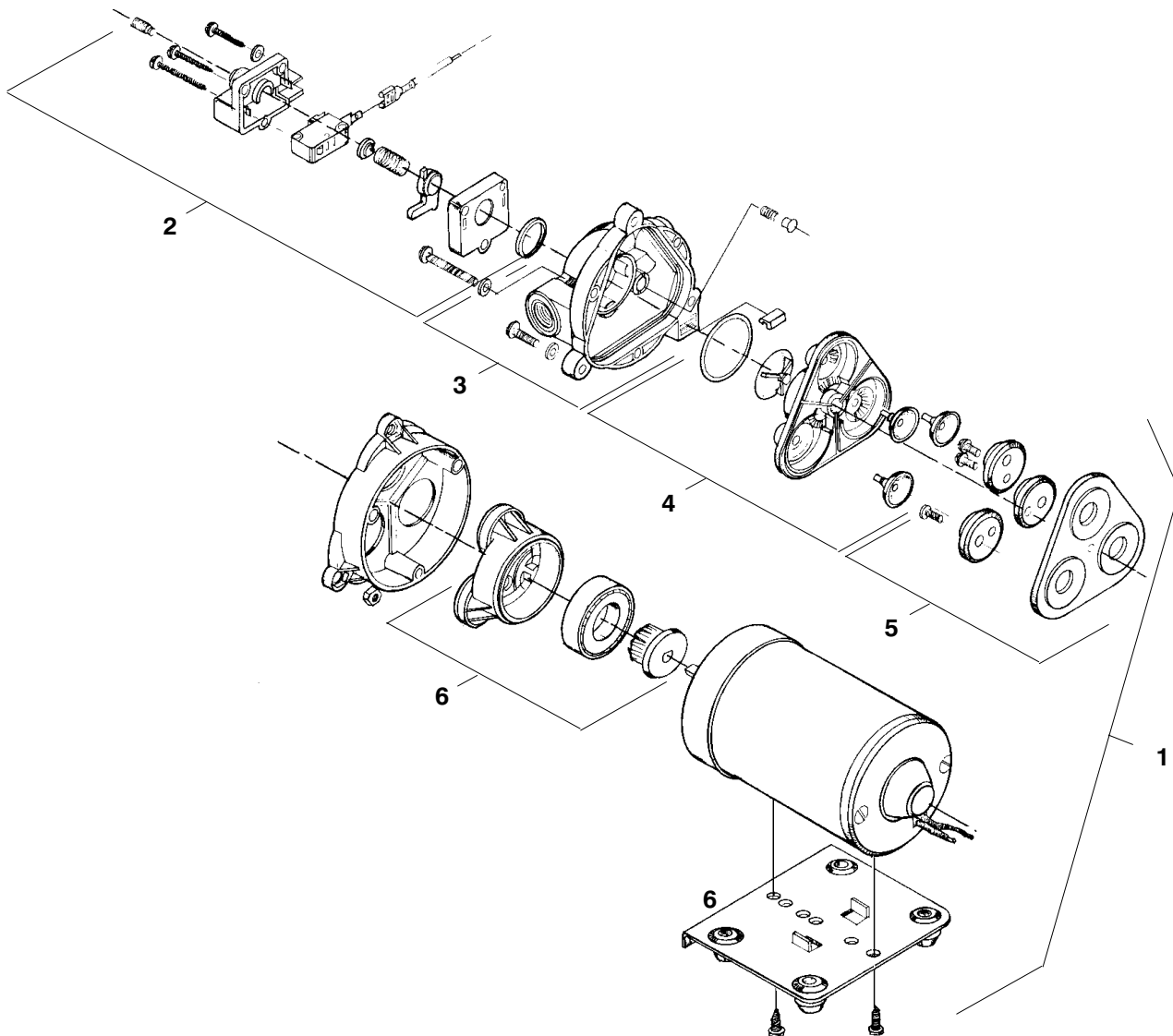

Ref	Part No.	Description	Qty.
1	180103	Pump, Solution Asm., 120V	1
1	180109	Pump, Solution Asm., 230V	1
2	190129	Kit, Pressure Switch	1
	190172	Kit Pressure Switch (Viton)	1
	190134	Kit, Diaphragm Only	1
3	190128	Kit, Upper Pump Housing	1
	190124	Kit, Check Valve Only	1
4	190171	Kit, Valve (Viton)	1
5	190131	Kit, Service	1
6	190130	Kit, Lower Pump Housing	1

**Vacuum Motor**

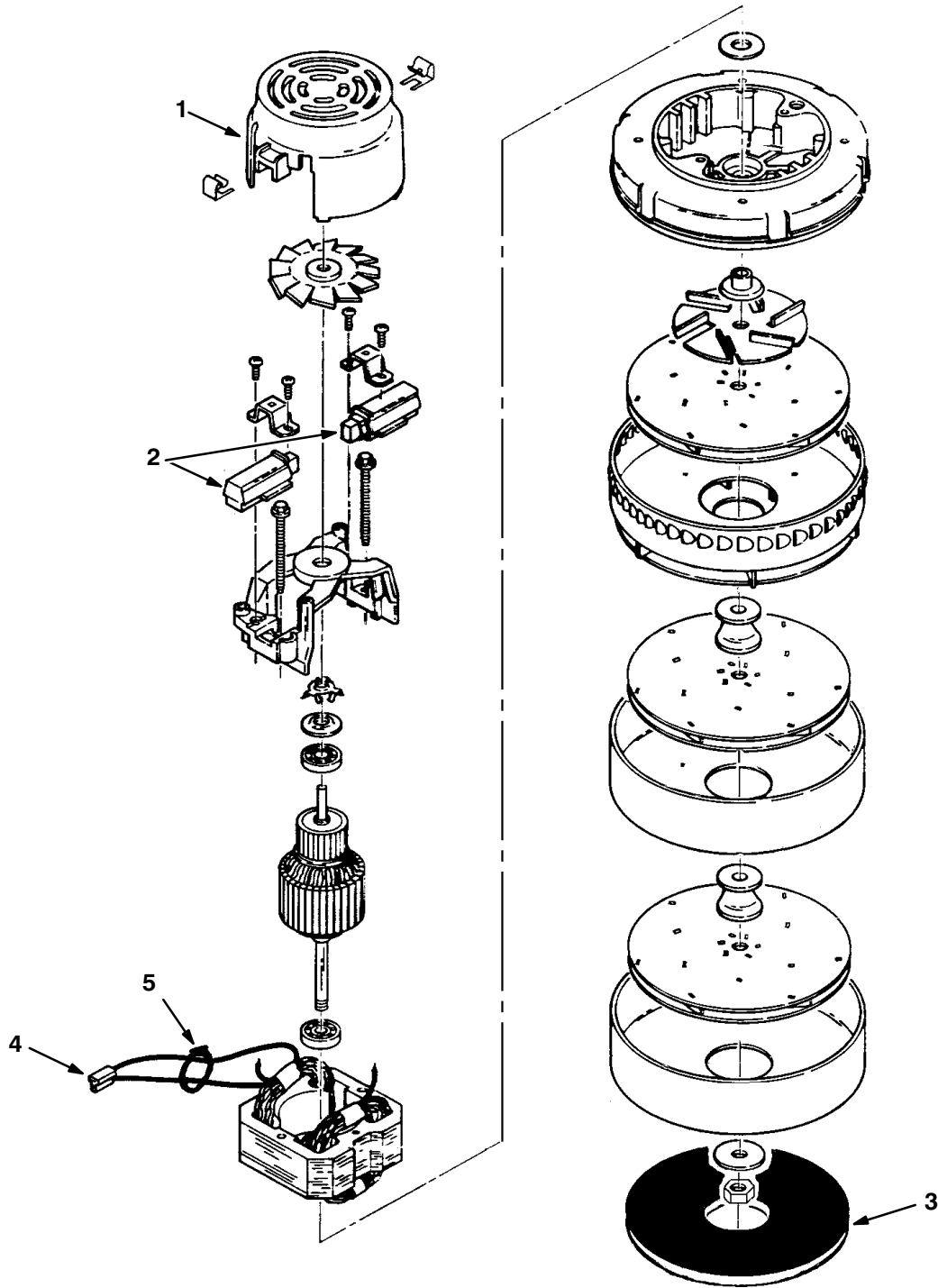

Ref	Part No.	Description	Qty.
▽	575243000	Vacuum Fan Assy 120V	1
▽	575034	Vacuum Fan Assy 230V	1
▲ 1	130487	Cover, Fan Motor	1
▲ 2	575381000	Brush, Fan Motor 120V	2
	575592	Brush, Fan Motor 230V	2
▲ 3	100038	Gasket, Foam	1
▲ 4	130096	Terminal	2
▲ 5	130040	Wire, Tie	1

Carpet Wand

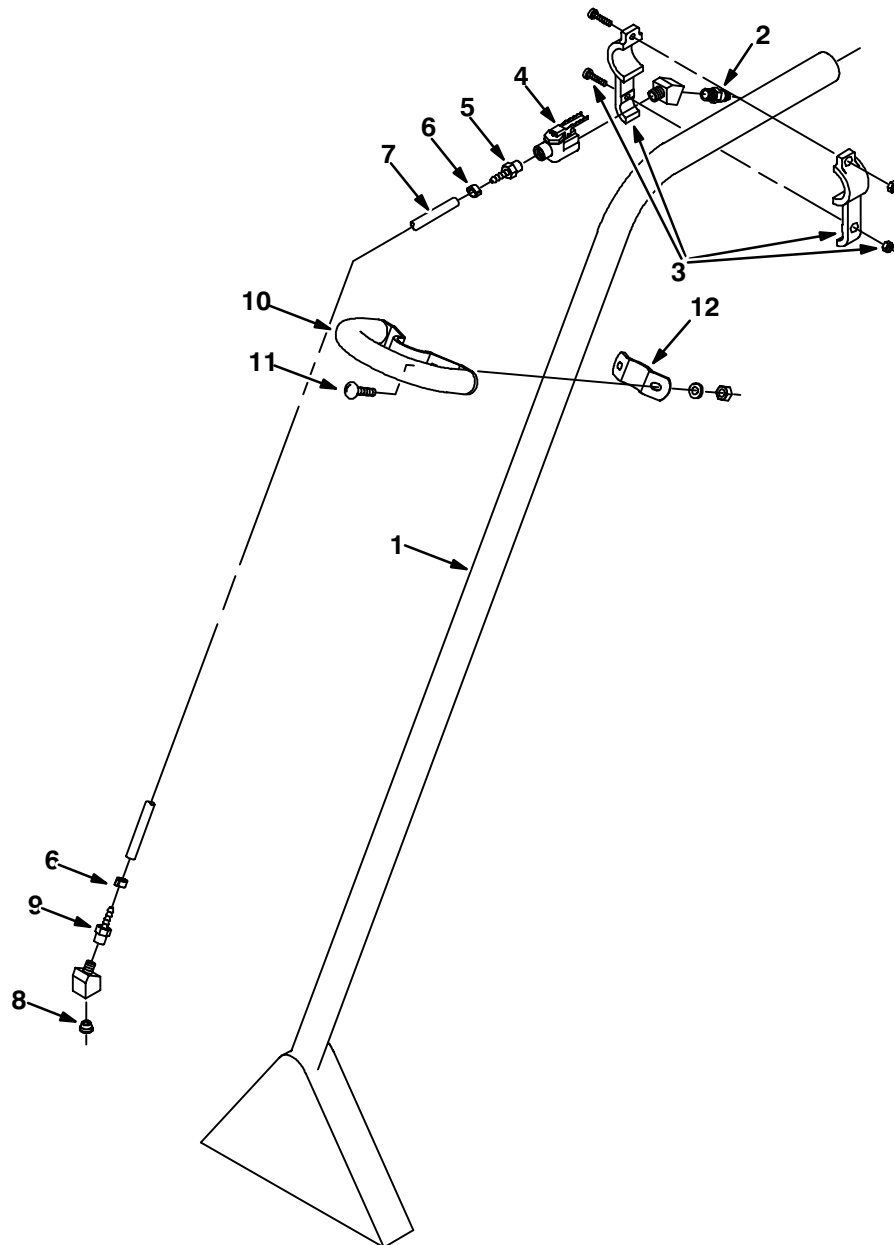

Ref	Part No.	Description	Qty.
1	575905000	Carpet Wand Assy	1
1	575907	Carpet Wand Assy w/ Handle	1
2	578091000	Plug, Quick Connect	1
3	578077000	Bracket, Valve	1
4	578064000	Valve, Water	1
5	578094000	Fitting, Hose Barb	1
6	578160000	Clamp, Hose	2
7	575523000	Hose, Reinforced	1
8	575529000	Tip, Spray	1
9	150510	Fitting, Hose	1
	578904000	Handle, Assy	1
10	578155000	Handle, Wand	1
11	578211000	Screw	2
12	578154000	Bracket, Handle	1

Hard Floor Wand

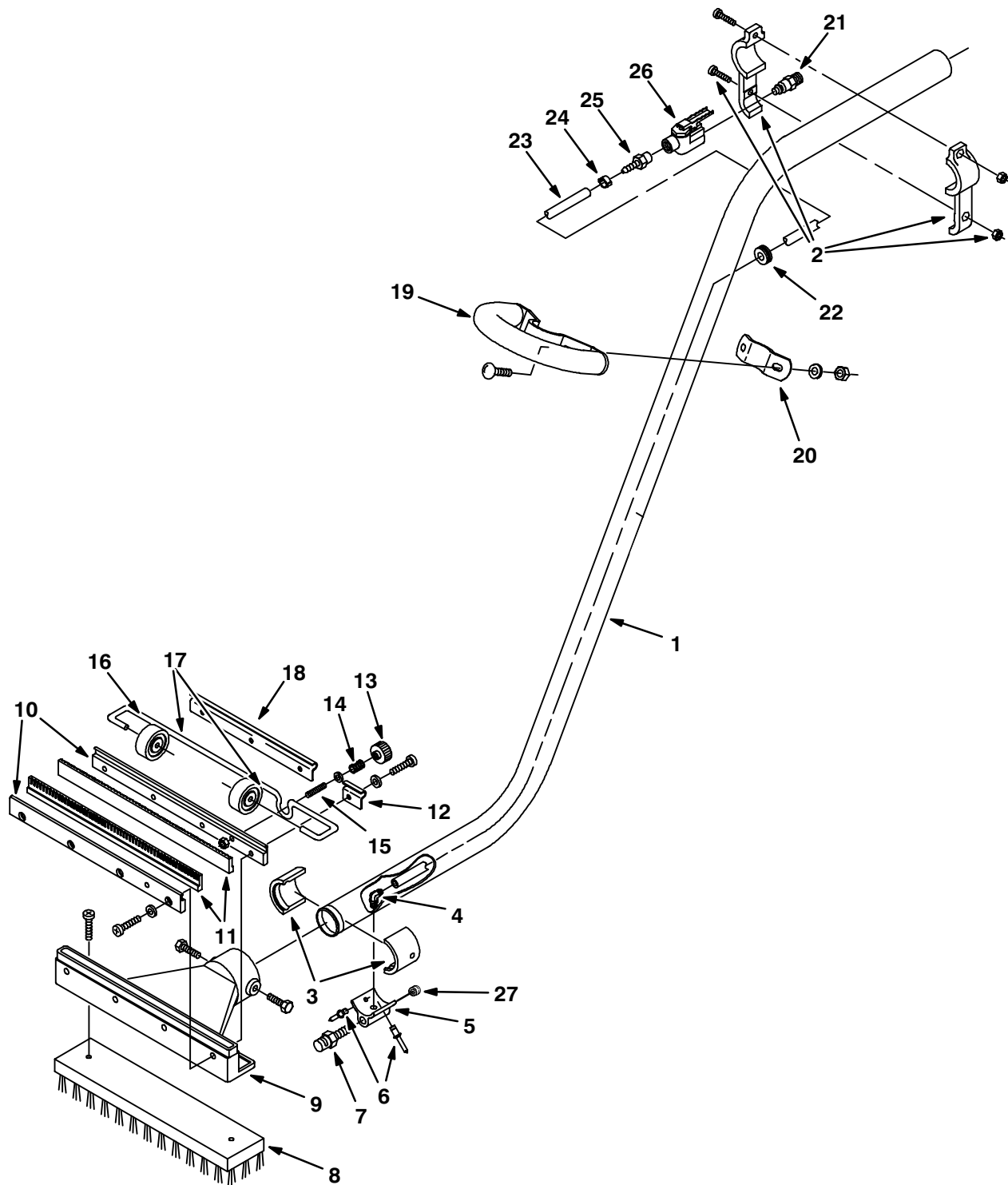

Hard Floor Wand

Ref	Part No.	Description	Qty.
▽	578905000	Wand Assy	1
▲ 1	578060000	Wand, Double Bend	1
▲ 2	578077000	Bracket, Valve	1
▲ 3	578061000	Adapter	2
▲ 4	578214000	Fitting, Elbow	1
▲ 5	579112	Adapter, Nozzle	1
▲ 6	579198	Rivet, Pop	2
▲ 7	578066000	Nozzle, Spray	1
▲ 8	578073000	Brush, Wand Att.	1
▲ 9	578063000	Head, Wand	1
▲ 10	578078000	Retainer, Squeegee	2
▲ 11	578074000	Blade, Squeegee	2
▲ 12	578124000	Bracket, Axle	1
▲ 13	578439	Nut, Thumb	1
▲ 14	578228000	Spring, Compres	1
▲ 15	578143000	Stud, Adjust.	1
▲ 16	578126000	Axle, Wand	1
▲ 17	578125000	Wheel, Guide	2
▲ 18	578123000	Bracket, Axle	1
▲ 19	578155000	Handle, Wand	1
▲ 20	578154000	Bracket, Handle	1
▲ 21	578091000	Male Quick-Conn.	1
▲ 22	578164000	Grommet	1
▲ 23	578821000	Hose, Solution	1
▲ 24	578161000	Clamp, Hose	2
▲ 25	578094000	Pipe, barb	1
▲ 26	578064000	Valve, Water	1
▲ 27	150208	Fitting, Plug	1

**Upholstery Tool**

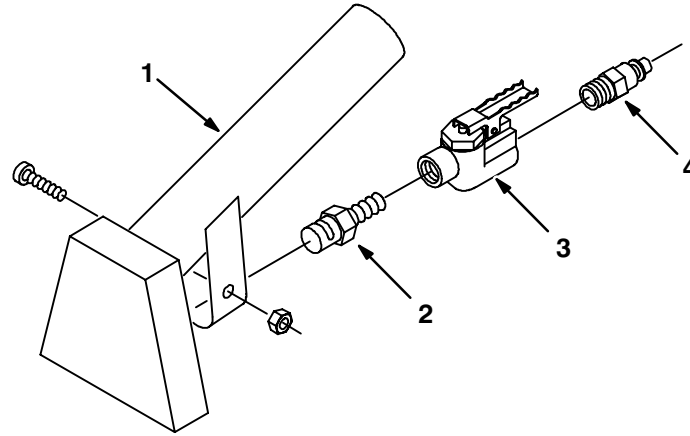

Ref	Part No.	Description	Qty.
▽ 1	575584	Upholstery Tool	1
▲ 2	575519000	Nozzle	1
▲ 3	578064000	Valve, Water	1
▲ 4	578091000	Plug, Quick Conn.	1

**Hose Assembly**

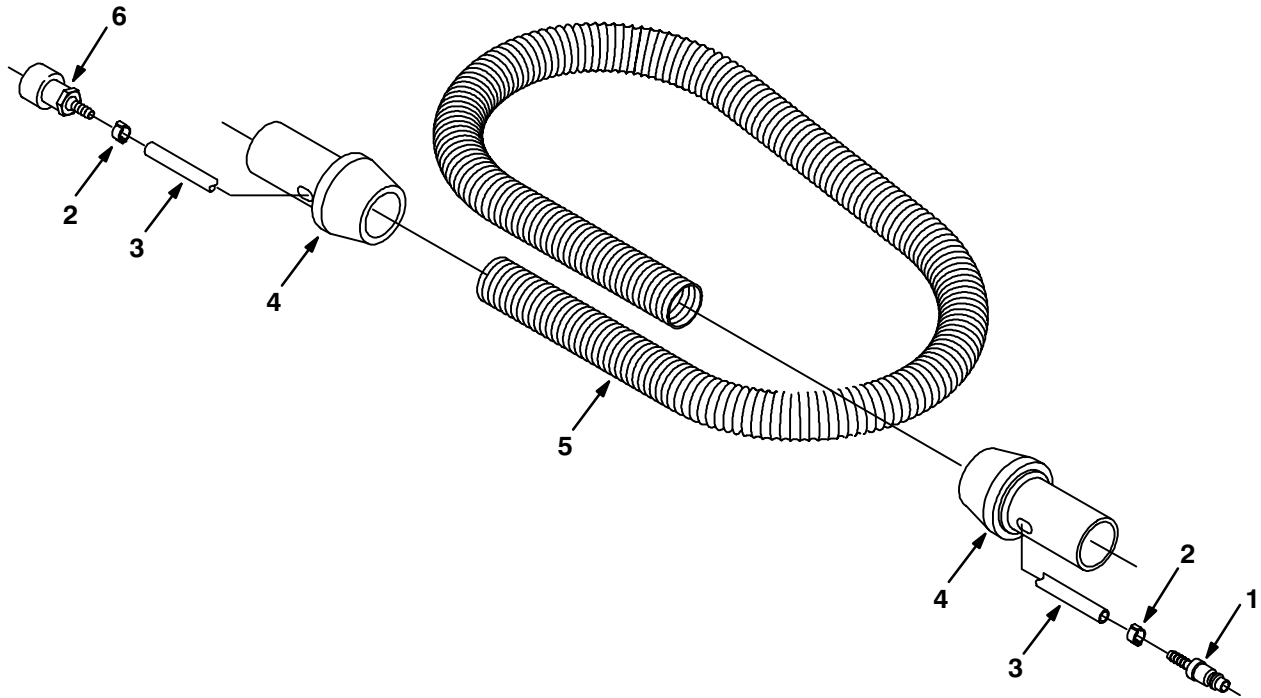

Ref	Part No.	Description	Qty.
▽	578903000	Hose Assy	1
▲ 1	578318000	Fitting, Quick conn.	1
▲ 2	578160000	Clamp, hose	2
▲ 3	578820000	Hose	1
▲ 4	578072000	Cuff, swivel	2
▲ 5	578276000	Hose, vacuum	1
▲ 6	578071000	Connector, quick F.	1