



# Magna Twin<sup>TM</sup> 1600/2200/2600

Dual Motor Vacuum  
Aspiradora con dos Motores

**Model No.:**  
608229 – 1600  
608230 – 2200  
608231 – 2600

**Operator and Parts Manual  
Manual del Operador y Piezas**

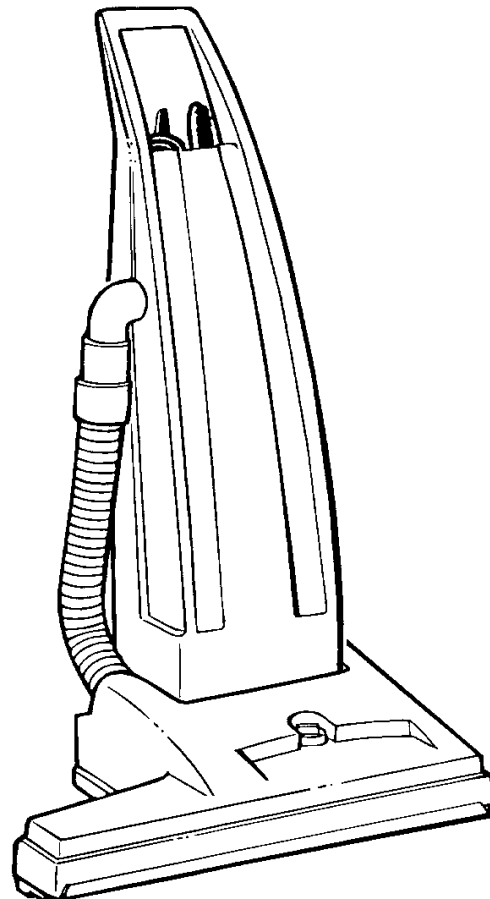

**NOBLES**  
12875 RANSOM STREET  
HOLLAND MI 49424 U.S.A.

**CUSTOMER SERVICE: 1-800-365-6625  
FAX: 1-800-678-4240**

**608593  
Rev. 01 (09-01)**

## 120V/230V LADDER

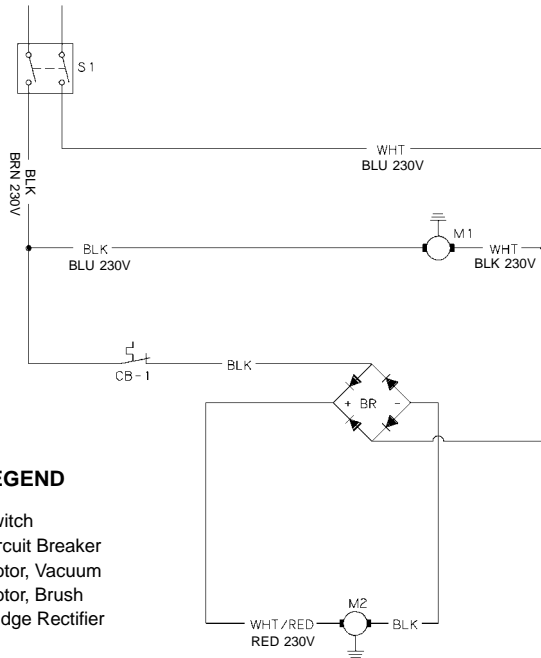

- REF LEGEND**
- S1 = Switch
  - CB1 = Circuit Breaker
  - M1 = Motor, Vacuum
  - M2 = Motor, Brush
  - BR = Bridge Rectifier

## 240V LADDER (EMC MODEL)

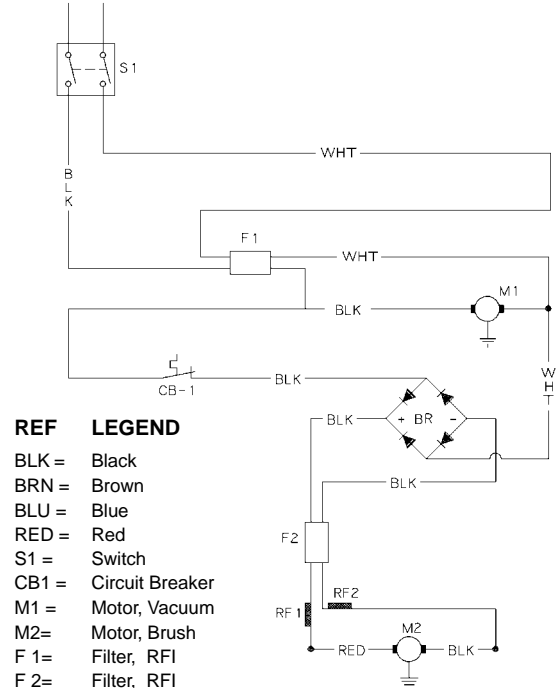

- REF LEGEND**
- BLK = Black
  - BRN = Brown
  - BLU = Blue
  - RED = Red
  - S1 = Switch
  - CB1 = Circuit Breaker
  - M1 = Motor, Vacuum
  - M2 = Motor, Brush
  - F1 = Filter, RF1
  - F2 = Filter, RF1
  - BR = Bridge Rectifier
  - RF1 = Choke, RF1
  - RF2 = Choke, RF1
  - WHT = White

## 120V/230V WIRING

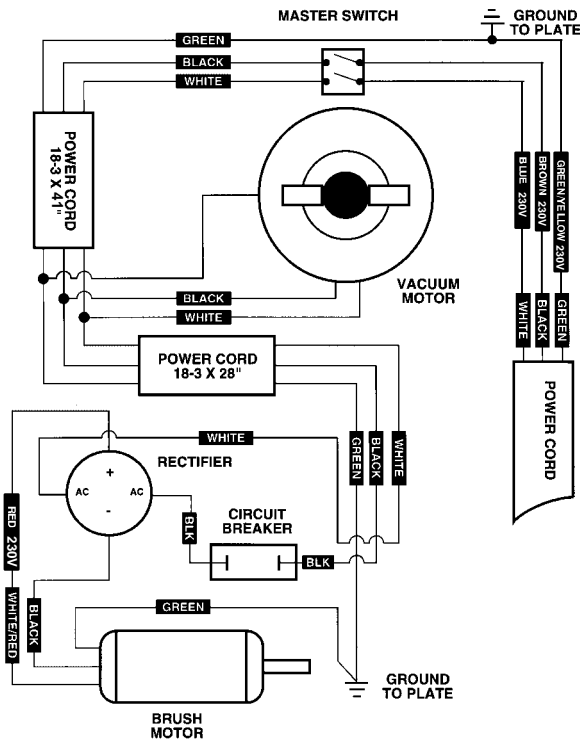

**UPPER UNIT**  
**PIEZAS DE SUPERIOR**

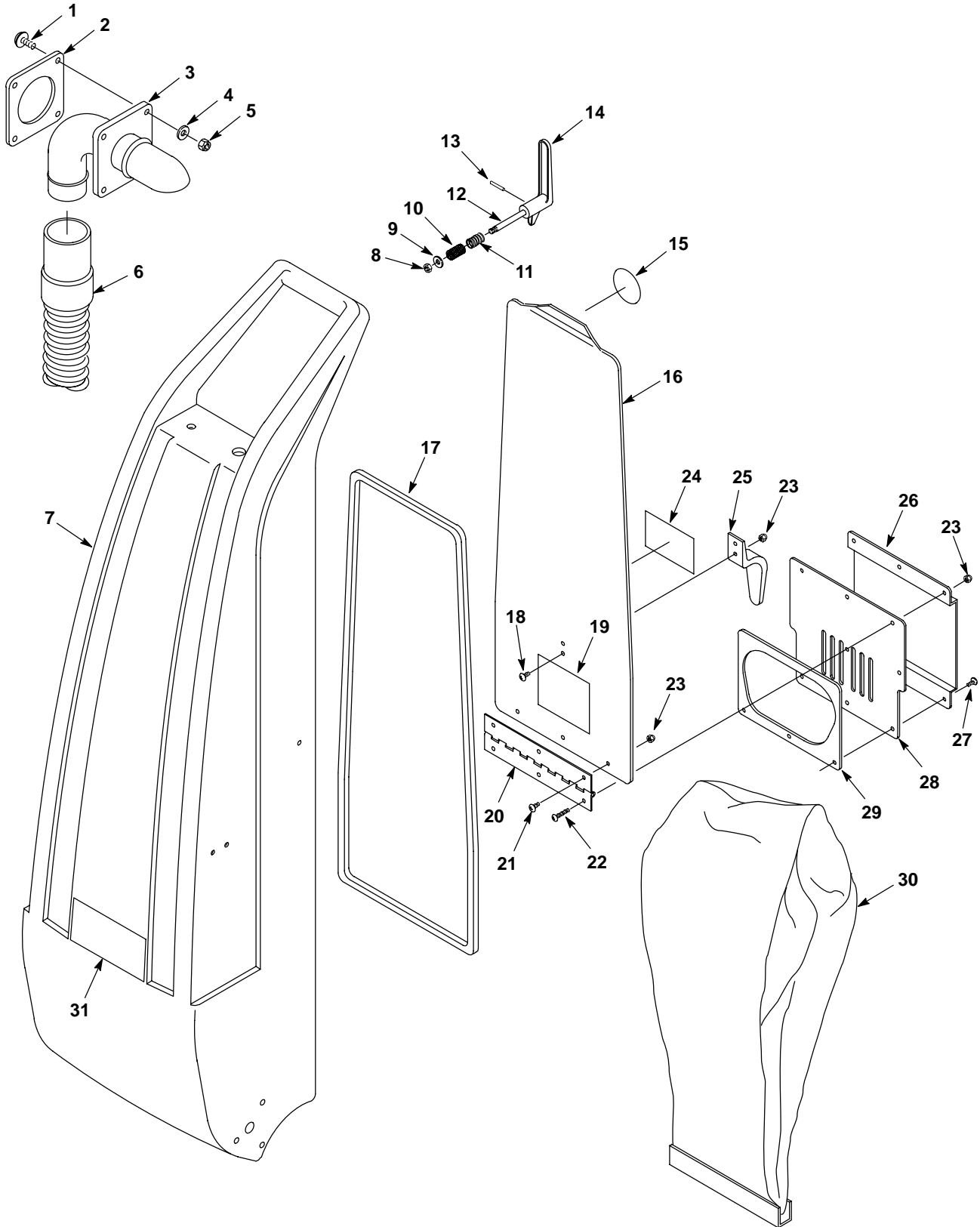

**UPPER UNIT**  
**PIEZAS DE SUPERIOR**

REF	PART #	DESCRIPTION	QTY.
1	140881	SCREW, MCH .25-20X1	4
2	100121	GASKET, ELBOW	1
3	608585	ELBOW, INLET, BLACK	1
4	140000	WASHER, FLAT	4
5	140501	NUT, LOCK	4
6	609011	HOSE, W/CUFF, 1.5" (1600)	1
6	609012	HOSE, W/CUFF, 2" (2200 & 2600)	1
7	608583	HANDLE, HOUSING (GREEN)	1
8	140545	NUT, .375	1
9	140013	WASHER, FLAT.375	1
10	605839	GUARD, SPRING	1
11	140419	SPRING, HANDLE	1
12	230245	SHAFT, LATCH	1
13	140610	PIN, ROLL	1
14	103053	●HANDLE, LATCH	1
15	N/A	DECAL, PREVENTIVE	1
16	608509	PANEL, REAR COVER, BLACK	1
17	100154	●GASKET, REAR DOOR	1

REF	PART #	DESCRIPTION	QTY.
18	140197	SCREW, 10-24X3/8"	2
19	120374	DECAL, IMPORTANT, KEEP VAC...	1
20	230244	HINGE	1
21	140197	SCREW, 10-24X3/8"	3
22	140823	SCREW, 10-24X.75	3
23	140511	NUT, ACORN 10-24	8
24	602595	DECAL, WARNING VACUUM CSA	1
25	230920.BK	HOOK, CORD	1
26	608510	COVER, EXHAUST BLACK	1
27	140823	SCREW, 10-24X5/8	3
28	608511	PLATE, EXHAUST BLACK	1
29	100139	●GASKET, EXHAUST	1
30	611784	●BAG, PAPER FILTER (CASE OF 100)	1
	900016	●BAG, CLOTH FILTER (OPTIONAL)	1
31	608186	DECAL, "NOBLES" LOGO	1

● RECOMMENDED STOCK ITEMS / ARTICULOS RECOMENDADOS

**UPPER UNIT - CONT.**  
**PIEZAS DE SUPERIOR - CONT.**

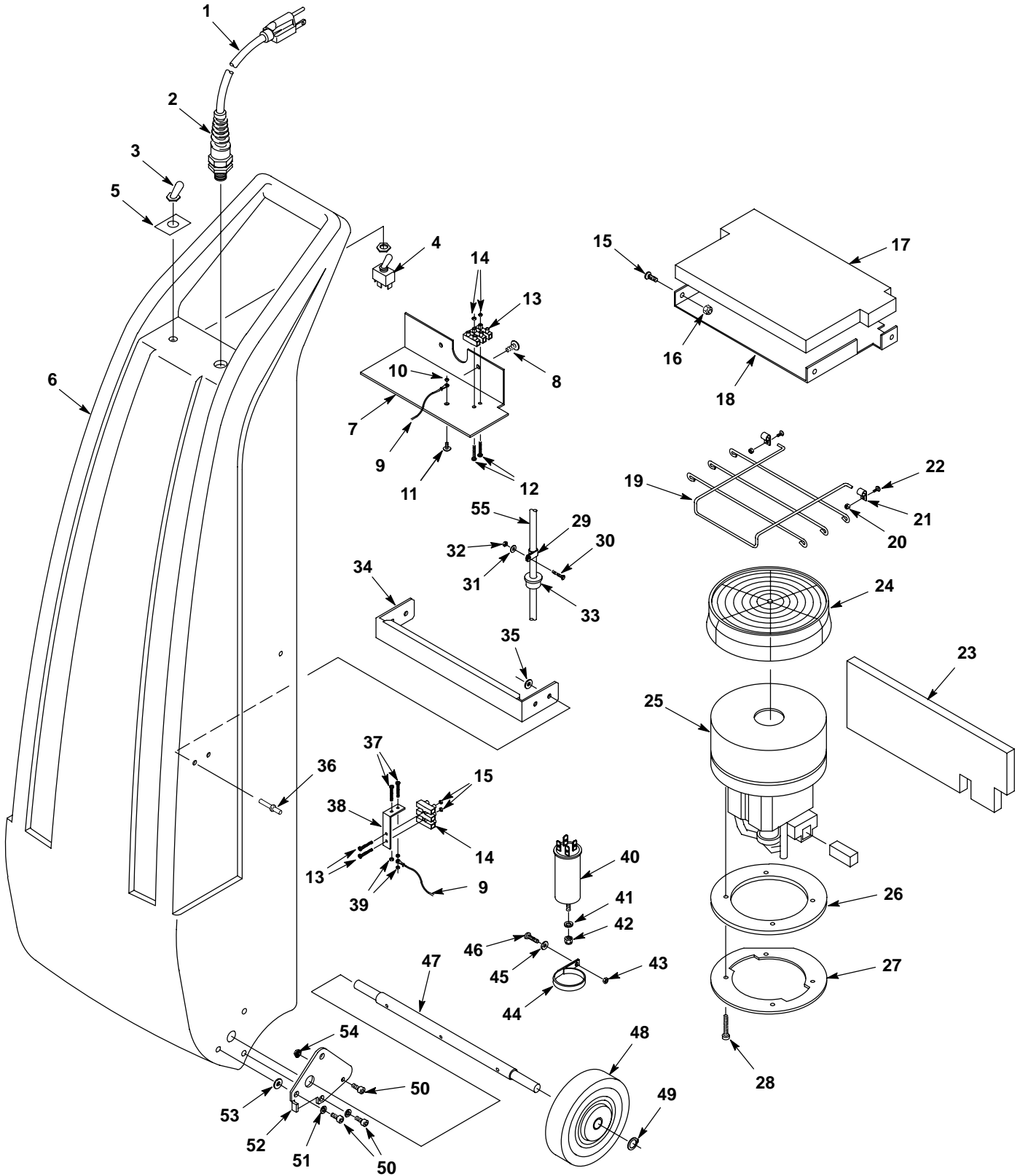

**UPPER UNIT - CONT.**  
**PIEZAS DE SUPERIOR - CONT.**

REF	PART #	DESCRIPTION	QTY.
1	130219	●CORD, 50'(15M) YELLOW 120V	1
	600324	CORD, 50'(15M) BLACK 230V/240V	1
2	130166	GRIP, CORD (230V/240V ONLY)	1
3	130990	●BOOT, SWITCH	1
4	130726	●SWITCH, TOGGLE	1
5	120300	DECAL, ON/OFF SWITCH	1
6	608583	HANDLE, HOUSING (GREEN)	1
7	230007	PLATE	1
	180014003	EDGING, PLASTIC 1/8"X.31M	1
8	140890	SCREW, PLATE	2
9	600692	CABLE, STRAIN RELIEF (EMC MODEL)	2
10	140519	NUT, 10-24 KEP (EMC MODEL)	1
11	140890	SCREW, 10-24X1/2 (EMC MODEL)	1
12	140879	SCREW, 6-32X3/4 (EMC MODEL)	4
13	130005	●TERMINAL, STRIP 25AMP (EMC MODEL)	2
14	140534	NUT, 6-32 (EMC MODEL)	4
15	590137	SCREW, 6-32X3/8 (EMC MODEL)	4
16	140066	NUT, 6-32 NYLOCK (EMC MODEL)	4
17	608228	FILTER, SUPPORT (EMC MODEL)	1
18	608226	SUPPORT, SCREEN (EMC MODEL)	1
19	230005	SUPPORT, WIRE BAG	1
20	140507	NUT, 4-40	2
21	140326	CLAMP	2
22	140566	SCREW, 4-40X.5	2
23	102527	TUFCOTE, EMBOSSED	1
24	180626	●FILTER, FOAM FRAME	1
25	130418	●MOTOR, VAC, 120V (1600 & 2200)	1
	190155	●BRUSHES, CARBON (2/PK)	2
	130483	●MOTOR, VACUUM, 120V (2600)	1
	190160	●BRUSHES, CARBON (2/PK)	2

REF	PART #	DESCRIPTION	QTY.
26	100122	●GASKET, MOTOR	1
27	240033	RING, MOUNT	1
28	140749	SCREW, 10-32X.75	3
29	140324	CLAMP, CABLE BLACK	3
30	140749	SCREW, 10-32X3/4	3
31	140054	WASHER, FLAT	3
32	140507	NUT, 4-40	3
33	240205	GROMMET, 5/16"X1"	1
34	605318	BRACE, HANDLE	1
35	140007	WASHER, FLAT	4
36	140703	RIVET, POP	4
37	2728.12	SCREW, 6-32X3/4 (EMC MODEL)	2
38	600695	BRACKET, TERMINAL STRIP (EMC MODEL)	1
39	140539	NUT, 6-32 KEP (EMC MODEL)	3
40	600383	●FILTER, RFI (EMC MODEL)	1
41	140062	WASHER, 5/16 EXT (EMC MODEL)	1
42	200101017	NUT, M8X1.25 HXJM (EMC MODEL)	1
43	140539	NUT, 6-32 KEP (EMC MODEL)	1
44	600749	CLAMP (EMC MODEL)	1
45	140011	WASHER, 3/16 FLAT (EMC MODEL)	1
46	140759	SCREW, 6-32X3/4 (EMC MODEL)	1
47	605319	AXLE, WHEEL	1
48	4109	●WHEEL, GRAY	2
49	605329	RING, RETAINER	2
50	602982	SCREW, .25-20X.5	3
51	140035	WASHER, HIGH COLLAR	2
52	230557	PLATE, LATCH	1
53	140000	WASHER, FLAT	1
54	140524	NUT, 1/4-20 KEP	1
55	130645	CORD, 18/3X41"	

● RECOMMENDED STOCK ITEMS / ARTICULOS RECOMENDADOS PARA MANTENER EN EXISTENCIA

LOWER UNIT  
PIEZAS DE INFERIOR

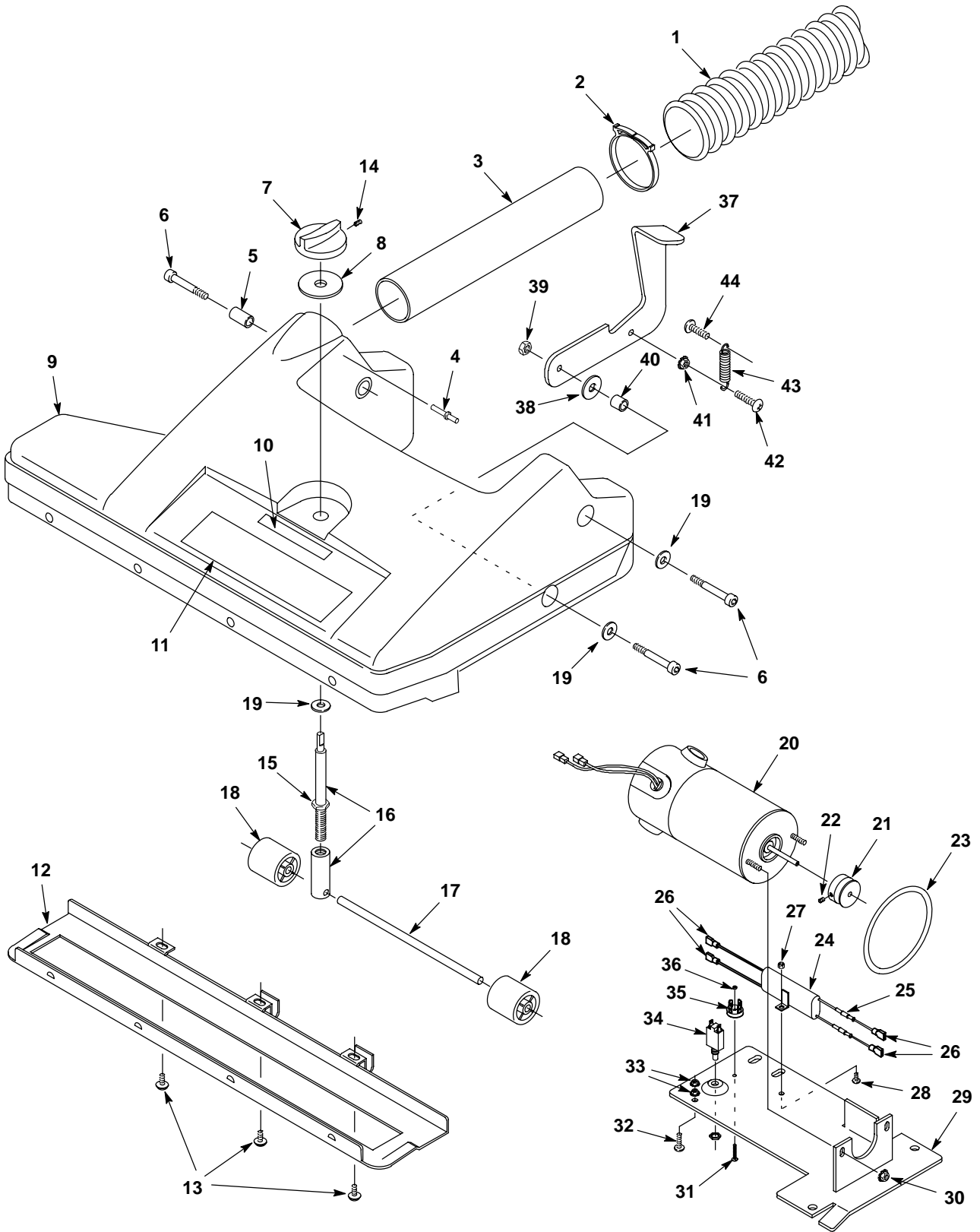

**LOWER UNIT**  
**PIEZAS DE INFERIOR**

REF	PART #	DESCRIPTION	QTY.
1	609011	●HOSE, W/CUFF, 1.5" (1600)	1
	609012	●HOSE, W/CUFF, 2" (2200 & 2600)	1
2	611205000	CLAMP, HOSE	1
3	240177	TUBE, BASE (1600)	1
	230555	TUBE, BASE (2200 & 2600)	1
4	140706	RIVET, POP	1
5	140903	BUSHING, ADJUSTING NYLON (16" MODEL)	1
	140905	BUSHING, ADJUSTING NYLON (22", 26" MODEL)	1
6	140239	SCREW, SHOULDER	3
7	130230	KNOB, HEIGHT ADJ.	1
8	140039	WASHER, FELT	1
9	608587	BASE, 16" (GREEN)	1
	608589	BASE, 22" (GREEN)	1
	608591	BASE, 26" (GREEN)	1
10	120299	DECAL, BRUSH HEIGHT ADJ.	1
11	608487	DECAL, MAGNA TWIN 1600	1
	608486	DECAL, MAGNA TWIN 2200	1
	608485	DECAL, MAGNA TWIN 2600	1
12	240026	PLATE, SHOE 16"	1
	230563	PLATE, SHOE 22"	1
	605417	PLATE, SHOE 26"	1
13	140832	SCREW, .25-20X.375	3
▽	700003	ASM., HEIGHT ADJ. (1600, 2200)	1
	600186	ASM., HEIGHT ADJ. (2600)	1
▲	140859	SCREW, 1/4-20X1/4 SK	1
▲	140545	NUT, 3/8"-16 FINJAM	1
▲	230842	PIVOT, BLOCK AND ADJ. SHAFT	1
▲	240130	SHAFT, AXLE ROLLER	1
18	605317	●ROLLERS, HEIGHT ADJT.	2
19	140036	WASHER, FLAT	3
20	130471	●MOTOR, BRUSH 120V	1
	190150	●-CARD, BRUSH	1

REF	PART #	DESCRIPTION	QTY.	
21	605315	●PULLEY, MOTOR	1	
22	140859	SCREW, 1/4-20X1/4 SK	1	
23	100047	●BELT, BRUSH DRIVE	1	
▽	601280	ASM., RFI FILTER (EMC MODEL)	1	
▲	24	600694	●FILTER, RFI BRUSH (EMC MODEL)	1
▲	25	600693	●CHOKER, 20UH 2.5A (EMC MODEL)	2
▲	26	281004001	●TERMINAL, FM .25 RED	4
27	28990	NUT, 8-32 NYLOCK	1	
28	140801	SCREW. 8-32X3/8"	1	
29	240027	PLATE, BRUSH MOTOR MOUNT	1	
30	140518	NUT, 10-32 KEP	2	
31	140829	SCREW, 6-32X1	1	
32	140823	SCREW, .25-20X.375	3	
33	140518	NUT, KEP 10-32	2	
34	130760	●CIRCUIT BREAKER 1.5A (120V)	1	
	578337000	CIRCUIT BREAKER 1.5A (230V/240V)	1	
35	130304	●RECTIFIER (120V)	1	
	130288	RECTIFIER (230V/240V)		
36	140539	NUT, KEP 6-32	1	
37	230558	PLATE, FOOT LATCH	1	
38	140027	WASHER, FLAT 5/16"	1	
39	140548	NUT, JAM 5/16"	1	
40	140925	SPACER, 3/16"	2	
41	140524	NUT, KEP .25-20	1	
42	15860.12	SCREW,.25-20X.75	1	
43	606334	●SPRING, LATCH	1	
44	140881	SCREW, .25-20X1.0	1	
N/S	130646	HARNESS, WIRE 18/3X28"	1	

▽ ASSEMBLY / CONJUNTO

▲ INCLUDED IN ASSEMBLY / INCLUIDO EN EL CONJUNTO

● RECOMMENDED STOCK ITEMS / ARTICULOS RECOMENDADOS



**BRUSH BREAKDOWN**  
**CONJUNTO DE CEPILLO**

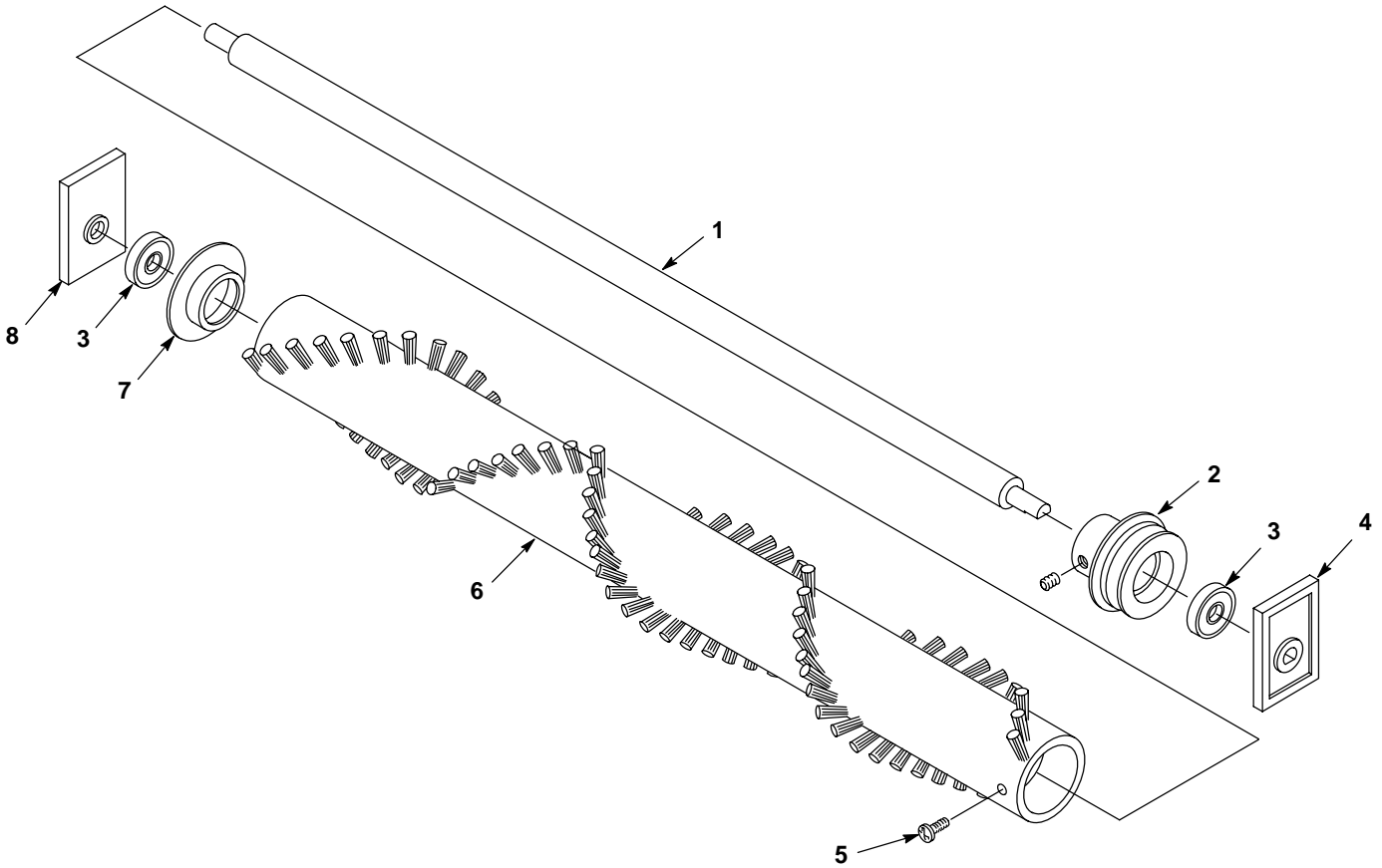

REF	PART #	DESCRIPTION	QTY.
∇	240035	ASM., BRUSH, 16"	1
	700865	ASM., BRUSH, 22"	1
	605419	ASM., BRUSH, 26"	1
▲ 1	605316	SHAFT, BRUSH 16"	1
	605391	SHAFT, BRUSH 22"	1
	605420	SHAFT, BRUSH 26"	1
▲ 2	240031	●PULLEY, BRUSH	1
▲ 3	140125	●BEARING, BRUSH	2
▲ 4	103016	●BLOCK, BRUSH SHAFT (W/ SLOT)	1

REF	PART #	DESCRIPTION	QTY.
▲ 5	140835	SCREW, 10-24X.375	2
▲ 6	240003	●BRUSH, CYLINDER 16"	1
	240066	●BRUSH, CYLINDER 22"	1
	605418	●BRUSH, CYLINDER 26"	1
	605423	-SLEEVE 26" (NOT SHOWN)	1
▲ 7	240024	CUP, BEARING	1
▲ 8	103017	●BLOCK, BRUSH SHAFT (W/O SLOT)	1

∇ ASSEMBLY / CONJUNTO

▲ INCLUDED IN ASSEMBLY / INCLUIDO EN EL CONJUNTO

● RECOMMENDED STOCK ITEMS / ARTICULOS RECOMENDADOS

TOOL ATTACHMENT KIT  
JUEGO ACCESORIO

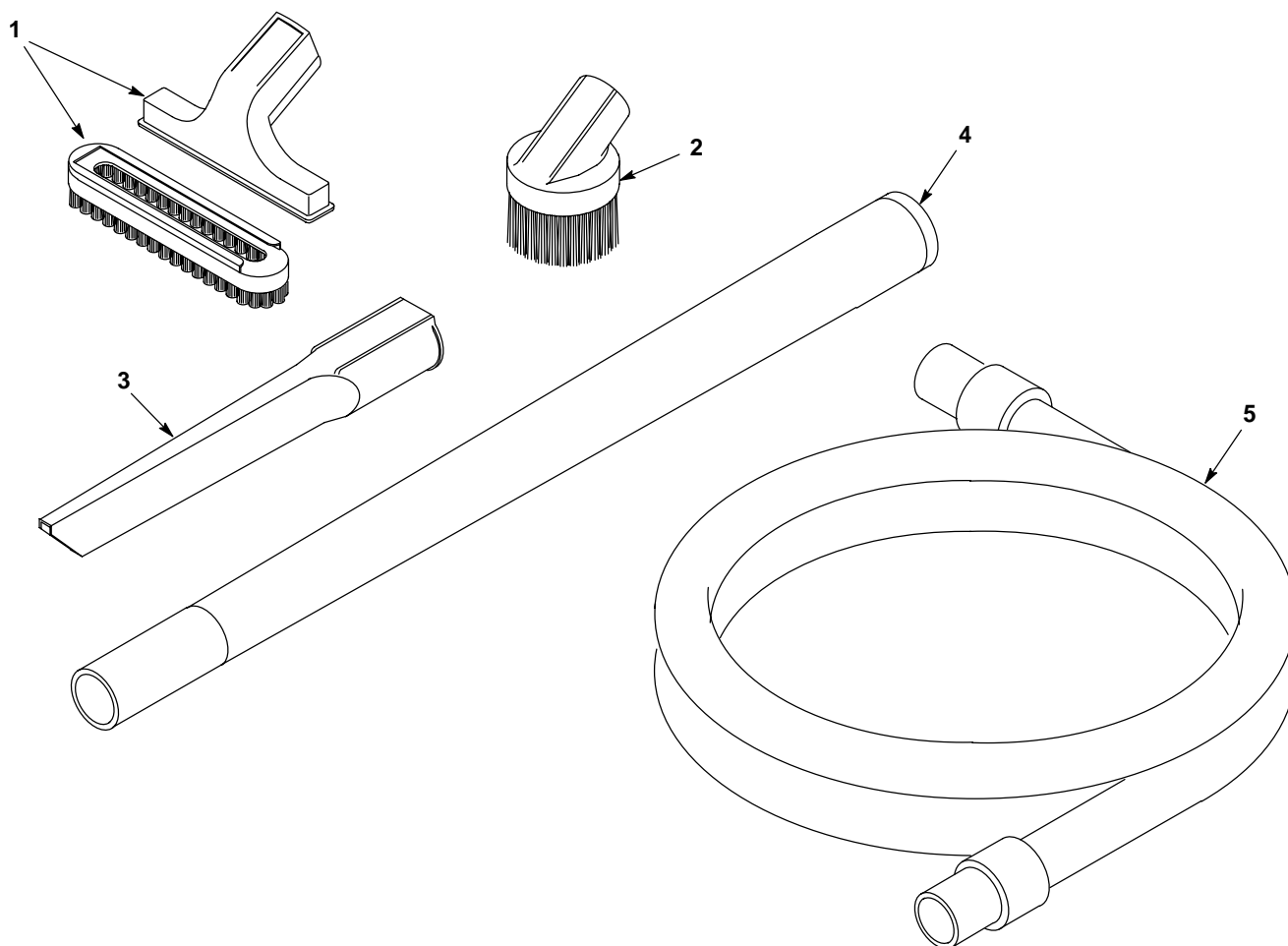

REF	PART #	DESCRIPTION	QTY.
▽	190048	●KIT, TOOL ATTACHMENT	1
▲ 1	*	TOOL, UPHOLSTERY	1
▲ 2	*	TOOL, DUSTING BRUSH	1

REF	PART #	DESCRIPTION	QTY.
▲ 3	*	TOOL, CREVICE	1
▲ 4	*	WAND, EXTENSION	1
▲ 5	*	HOSE, 5' BLACK	1

▽ ASSEMBLY / CONJUNTO

▲ INCLUDED IN ASSEMBLY / INCLUIDO EN EL CONJUNTO

● RECOMMENDED STOCK ITEMS / ARTICULOS RECOMENDADOS

\* NOT SOLD SEPARATELY / NO SE VENDE POR SEPARADO

**CLEAN AIR EXHAUST FILTER KIT  
JUEGO FILTRO**

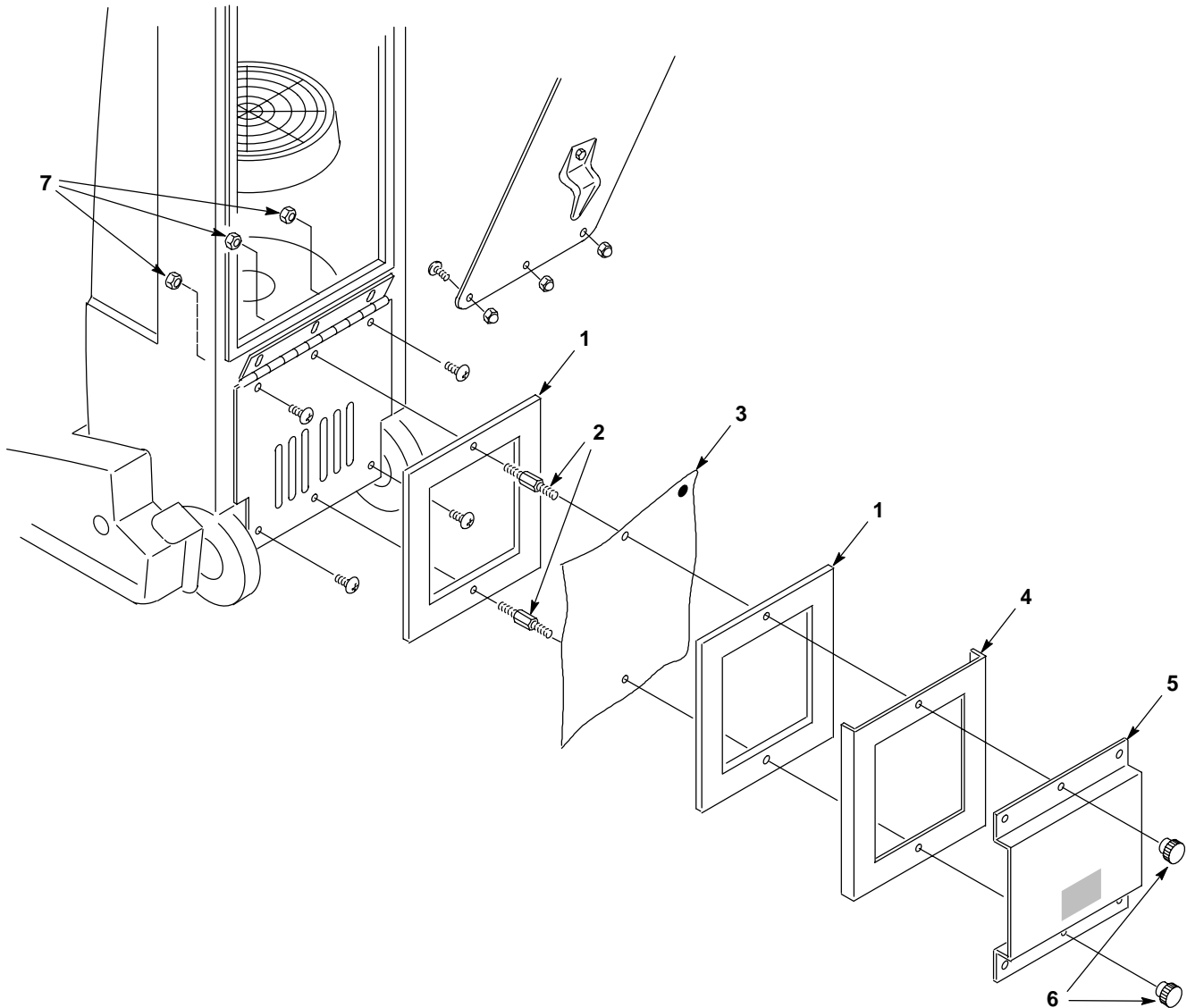

REF	PART #	DESCRIPTION	QTY.
▽	190973	●KIT, CLEAN AIR EXHAUST FILTER	1
▲	1	102570 GASKET, FILTER	2
▲	2	140606 SCREW, STANDOFF	2
▲	3	900009 FILTER, FOAM EXHAUST	1

REF	PART #	DESCRIPTION	QTY.
▲	4	173317 INSERT, EXHAUST FILTER	1
▲	5	230965.WH PLATE, EXHAUST FILTER	1
▲	6	240239 KNOB, THUMB	2
▲	7	140552 NUT, NYLOCK	3

▽ ASSEMBLY / CONJUNTO

▲ INCLUDED IN ASSEMBLY / INCLUIDO EN EL CONJUNTO

● RECOMMENDED STOCK ITEMS / ARTICULOS RECOMENDADOS