

American-Lincoln®

The Power Behind Clean

6150 Compact Rider Sweeper



Compact Rider Sweeper Offers High Performance Cleaning

The 6150 rider sweeper can easily maneuver the narrowest aisles or most congested machinery areas to pick up a variety of debris, including fine dust, dirt, metal chips, broken glass and paper. This high-performance sweeper can make quick work of your toughest sweeping tasks.

Durable features designed to last:

- Heavy-duty hydraulic drive and power steering result in low maintenance
- Front bumper withstands 5-mph impact without machine or wall damage
- Steel debris hopper operates under rugged conditions
- Flat-faced o-ring seals comparable to aircraft use prevent hydraulic leakage
- Extra-rugged, one-piece unitized steel frame

Productivity features include:

- Patented filter shaker system supplies unmatched filter clean-back
- Extra-large door to 10-cubic-foot hopper permits easy access for removing big items
- No tools required to change main broom, side broom or panel filter
- Ground clearance of 4.5 inches allows pick up of wide range of debris



Extra-large door to 10-cubic-foot hopper permits easy removal of big items often left behind.



Easy access for no-tool dust filter removal. Patented filter shaker results in longer sweeping duration. Optional poly filter for sweeping in damp conditions.



Broom maintenance is kept to a minimum with the swing-out idler arm and no-tool broom removal features.

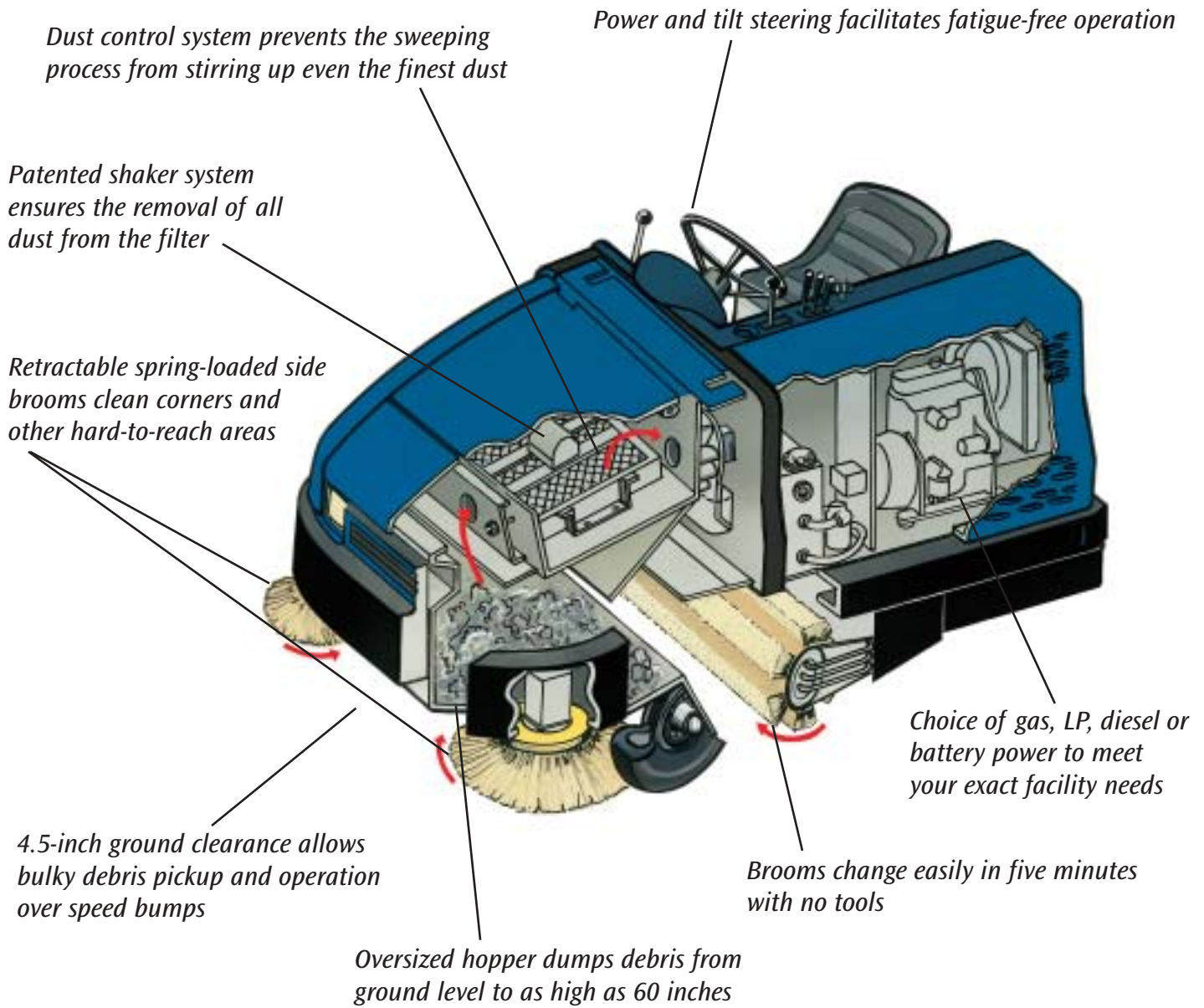

Available engine choices include Kubota 3-cylinder and Kawasaki 2-cylinder gas or LP or Kubota 3-cylinder diesel to meet your power needs.



10-cubic-foot hopper dumps debris from ground level to as high as 60 inches for quicker handling.



Dual side broom option sweeps a 62 inch path for increased productivity.

6150

Compact Rider Sweeper

American-Lincoln®

The Power Behind Clean

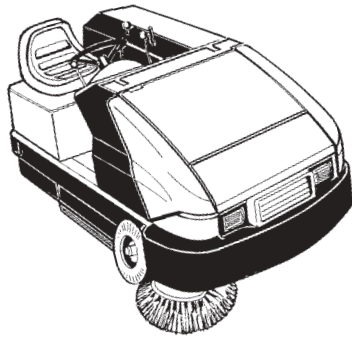

KEY FEATURES

- Choice of gas, LP, diesel or battery power meets your exact facility needs
- 4.5-inch ground clearance results in wide range of debris pickup
- Large capacity hopper and dust filter lengthen sweeping duration
- Heavy-duty steel hopper lasts a long time
- Ability to change main broom, side broom and panel filter without tools lowers maintenance costs

SPECIFICATIONS

Sweeping path with side broom	50 in. (127 cm)
Sweep path with dual side brooms	62 in. (157.4 cm)
Hopper capacity	10 cu. ft. (282 l)
Dump height	0-60 in. (0-152.4 cm)
U-turn aisle width	90 in. (229 cm)
Dust filter	78 sq. ft. (198 sq cm)
Main broom	36 x 14 in. (91.4 x 35.5 cm)
Side broom	21 in. (53.3 cm)
Battery Power	36 volt, 2.5 hp drive motor
Engines	20 hp, 2 cyl. Kawasaki gas or LP 24 hp, 3 cyl. Kubota gas or LP 20 hp, 3 cyl. Kubota diesel
Dimensions (L x W x H)	87 x 54.75 x 53 in. (221 x 139 x 135 cm)
Weight (gas, LP, diesel)	2,100 lbs.(955 kg)
Weight (battery unit with battery)	3,420 lbs. (1,555 kg)

WHO USES THIS MACHINE?

- Manufacturing plants
- General warehouses
- Parking garages
- Glass manufacturing plants
- Automotive plants

WHAT DOES IT DO BEST?

- Picks up debris and dust aggressively
- Controls even the finest dust
- Reduces operator fatigue with ergonomic controls
- Provides more productivity and less downtime because of low maintenance

WHAT ENHANCES ITS PRODUCTIVITY?

- Hydraulic systems and power steering for reliable operation
- Large debris hopper and dust collection filter for less dumping
- Variable height dump system for faster operation

WHAT ARE ITS SAFETY FEATURES?

- Rack and pinion power steering for better handling
- Hopper safety arm
- Excellent line-of-sight from operator's compartment

WHAT ADDS TO ITS DURABILITY?

- Flat-faced, o-ring seals for less hydraulic system maintenance
- Heavy gauge welded steel chassis with 5-mph bumper
- Heavy-duty hydraulic system backed by three-year warranty
- All steel frame and hopper

American-Lincoln

1100 Haskins Rd
Bowling Green, OH 43402
www.americanlincoln.com

DISTRIBUTED BY:

Customer Service: 1-800-331-7692
Fax Orders to: 1-877-877-2586
Technical Service: 1-800-331-7691

©2004 ALTO U.S. Inc., All Rights Reserved. Specifications subject to change without notice. 79706A

