

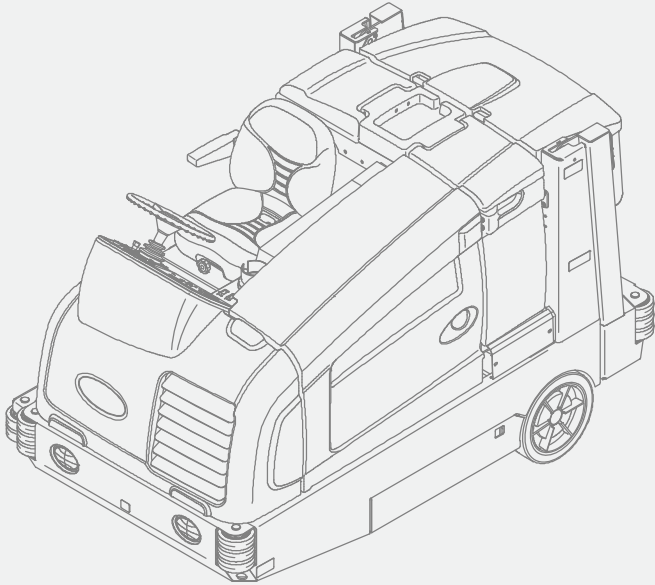

M20/M30

(S/N 008000-)

Sweeper Scrubber Service Manual



ES[®] Extended Scrub System
Tennant True[®] Parts
IRIS[®] a Tennant Technology
Pro-Panel[™] Controls
Insta-Fit[™] Adapter



North America / International



For the latest Parts Manuals and other
language Operator Manuals, visit:

www.tennantco.com/manuals

9016006
Rev. 01 (03-2017)



INTRODUCTION

This manual is furnished with each new model. It provides necessary operation and maintenance instructions.



Read this manual completely and understand the machine before operating or servicing it.

This machine will provide excellent service. However, the best results will be obtained at minimum costs if:

- The machine is operated with reasonable care.
- The machine is maintained regularly - per the machine maintenance instructions provided.
- The machine is maintained with manufacturer supplied or equivalent parts.

	PROTECT THE ENVIRONMENT	MACHINE DATA	
	Please dispose of packaging materials, used components such as batteries and fluids in an environmentally safe way according to local waste disposal regulations.	Please fill out at time of installation for future reference.	
	Always remember to recycle.	Model No. - _____	
		Serial No. - _____	
		Installation Date - _____	

INTENDED USE

The M17 is an industrial rider machine designed to wet scrub and sweep both rough and smooth hard surfaces (concrete, tile, stone, synthetic, etc). Typical applications include schools, hospitals / health care facilities, office buildings, and retail centers. Do not use this machine on soil, grass, artificial turf, or carpeted surfaces. This machine is intended for indoor use only. This machine is not intended for use on public roadways. Do not use this machine other than described in this Operators Manual.

Tennant Company

PO Box 1452

Minneapolis, MN 55440

Phone: (800) 553-8033 or (763) 513-2850

www.tennantco.com

DFS (Dual Force Sweeping), PerformanceView, Pro-ID, Pro-Check, Perma-Filter, ShakeMax, Zone Settings, SmartRelease, QA Controls, 1-Step, Dura-Track, Touch-N-Go, Duramer, are trademarks of Tennant Company.

Specifications and parts are subject to change without notice.

Original Instructions, copyright © 2017 TENNANT Company, Printed in U.S.A.

CONTENTS

Contents	3	Engine Oil Pressure And Temperature Sensor.....	64
Specifications	7	Fuel Pump And Speed Control Output	65
M30 General Machine Dimensions / Specifications	7	Fuel Pump	66
M20 General Machine Dimensions / Specifications	12	Engine Speed Control.....	67
Electrical Component Locator	17	M_series Enable / Disable Chart	68
M Series Electrical Component Locator	17	M_series Control Board Connectors.....	69
Electrical	32	M_series Fault Condition Chart	70
Electrical Schematic Symbols.....	32	M_series Condition And Warning Indicators.....	71
Electrical Option Components	33	General Information	73
Key Power Distribution	34	M20_m30 Operational Matrix	75
Key Power Distribution	35	M20_m30 Option Components.....	76
Key On Power Distribution.....	36	M20_m30 Hydraulic Component Locator Side Brush Motor - Sweep Fan Motor - Scrub Fan Motor Propel Motor - Main Brush Motor - Side Squeegee Lift Cylinder.....	77
Main Brushes On	37	M20_m30 Hydraulic Component Locator Hopper Cylinder - Scrub Head Cylinder - Side Brush Extend Cylinderside Squeegee Cylinder - Main Brush Motor.....	78
Hopper Lift	38	M20_m30 Hydraulic Component Locator Sweep Fan Valve - Scrub Manifold - Sweep Manifold.....	79
Hopper Lower	39	M20_m30 Hydraulic Component Locator Steering Cylinder - Hopper Door Cylinder -	80
Scrub Vacuum Fan On & Squeegee Down	40	Rear Squeegee Lift Cylinder.....	80
Hopper Door Open	41	M20_m30 Hydraulic Component Locator Hose Group - Steering And Propel	81
Side Brush On	42	M20_m30 Hydraulic Component Locator Hose Group - Pump And Vacuum Fan	82
Side Brush On	43	M20_m30 Hydraulic Component Locator Hose Group - Brush And Hopper	83
Shaker Motor On	44	M20_m30 Hydraulic Component Locator Hose Group - Squeegee Lift	84
Solution & Recovery Float Switches.....	45	M20_m30 Scrub/Sweep Head Lower	85
Forward Propel	46	M20_m30 Scrub/Sweep Head Lift.....	86
Auto Fill Solenoids.....	47	M20_m30 Squeegee Lower.....	87
Conventional Detergent Pump & Es Pump.....	48	M20_m30 Squeegee Lift.....	88
Horn	49	M20_m30 Main Brushes On	89
Hopper Door Closed	50	M20_m30 Side Brush On	90
Reverse Propel.....	51	M20_m30 Scrub Vacuum Fan On	91
Shutdown Relay (Normal Machine Operation)	52		
Shutdown Relay (Normal Machine Operation)	53		
Shutdown Relay (Shutdown Mode)	54		
Shutdown Relay (Shutdown Mode)	55		
Starting System On.....	56		
Starting System On.....	57		
Glow Plugs On.....	58		
Conventional Main & Side BrushSolution Valves...	59		
Fast System On	60		
Fuel Level Sensor (Gas / Lp / Diesel).....	61		
Impact, Hydraulic Temperature & Filter Sensors	62		
Engine Oil Pressure, Temperature, And Mil System	63		

CONTENTS

M20_m30 Scrub Vacuum Fan & Side Brush On.....	92
M20_m30 Scrub Vacuum Fan On	93
M20_m30 Scrub Vacuum Fan & Side Brush On.....	94
M20_m30 Pressure Washer On	95
M20_m30 Hopper Lift	96
M20_m30 Hopper Lower	97
M20_m30 Hopper Door Open	98
M20_m30 Hopper Door Close	99
M20_m30 Side Brush Lower	100
M20_m30 Side Brush Lift	101
M20_m30 Side Brush Extend	102
M20_m30 Side Brush Retract.....	103
Hydraulic Solenoid Valve Details	104
M20_m30 Fault Codes (Propanel And Standard Panel)	105
M Series Maintenance	112
Troubleshooting.....	147
M20/M30 Membrane Panel Service Modes	147
Service Mode	147
Manual Mode.....	148
Configuration Mode	149
Additional Water Level Setting Information:	150
Self Test Mode	150
Throttle Adjust Mode.....	152
Down Pressure Adjust Mode	154
Membrane Test Mode	155
Service Mode.....	156
M20/M30 Propanel Service Modes.....	157
Configuration Mode	158

SPECIFICATIONS

M30 GENERAL MACHINE DIMENSIONS / SPECIFICATIONS

M30 GENERAL MACHINE DIMENSIONS/CAPACITIES

Item	Dimension/Capacity
Length	2745 mm (108 in)
Height	1475 mm (58 in)
Height (with overhead guard)	2135 mm (84 in)
Width/frame (roller to roller)	1475 mm (58 in)
Width (rear squeegee)	1500 mm (59 in)
Width (with side brush)	1625 mm (64 in)
Cleaning path width (Main brush length)	1220 mm (48 in)
Cleaning path width (with scrubbing side brush)	1575 mm (62 in)
Cleaning path width (with sweeping side brush)	1625 mm (64 in)
Main brush diameter (2)	305 mm (12 in)
Side brush diameter (scrubbing)	410 mm (16 in)
Side brush diameter (sweeping)	535 mm (21 in)
Solution tank capacity	284 L (75 gallons)
Recovery tank capacity	360 L (95 gallons)
Debris hopper volume capacity	198 L (7.0 ft ³)
Debris hopper weight capacity	295 kg (650 lbs)
Dump height (variable to)	1525 mm (60 in)
Minimum ceiling dump height	2620 mm (103 in)
Weight - empty	1815 Kg (4000 lbs)
GVWR	2449 Kg (5400 lbs)
Transport ground clearance	80 mm (3 in)
Protection Grade	IPX3

Values determined as per IEC 60335- 2- 72	Measure
Sound pressure level L_{pA}	84 dB(A)
Sound uncertainty K_{pA}	3.0 dB(A)
Sound power level L_{WA} + Uncertainty K_{WA}	106 dB(A)
Vibration - Hand- arm	< 2.5 m/s ²
Vibration - Whole body	< 0.5 m/s ²

SPECIFICATIONS

M30 GENERAL MACHINE DIMENSIONS / SPECIFICATIONS - (CONTINUED)

M30 POWER TYPE

Engine	Type	Ignition	Cycle	Aspiration	Cylinders	Bore	Stroke
Mitsubishi 2.0	Piston	Coil @ Plug	4	Natural	4	85 mm (3.35 in)	88 mm (3.46 in)
	Displacement		Tennant machine governed net power			Engine mfg un-governed net power	
	1997 cc (122 cu in)		37.3 kw (50 hp) @ 2300 rpm			44.7 kw (60 hp) @ 30 00 rpm	
	Fuel		Cooling system			Electrical system	
	Gasoline, 87 octane minimum, unleaded Fuel tank: 42 L (11.2 gal)		Water/ethylene glycol antifreeze			12 V nominal	
	LPG, Fuel tank: 15 kg (33 lb)		Total: 7.5 L (2 gal) Radiator: 3.8 L (1 gal)			75 A alternator	
	Idle speed, no load		(Fast) governed speed, under load			Firing order	
	1350 ± 50 rpm		2300 ± 50 rpm			1- 3- 4- 2	
	Spark plug gap		Valve clearance, cold			Engine lubricating oil with filter	
	1.1 mm (0.043 in)		No Adjustment OHC Engine			4.7 L (5 qt) 5W30 SAE- SG/SH	

Engine	Type	Ignition	Cycle	Aspiration	Cylinders	Bore	Stroke
Kubota V1505- TB	Piston	Diesel	4	Charged / Turbo	4	78 mm (3.07 in)	78.4 mm (3.08 in)
	Displacement		Tennant machine governed net power			Engine mfg un-governed net power	
	1500 cc (91.4 cu in)		25.4 kw (34 hp) @ 2800 rpm			27.2 kw (44.2 hp) @ 3000 rpm	
	Fuel		Cooling system			Electrical system	
	Diesel Fuel tank: 42 L (11.2 gal) low sulfur fuel content less than 500ppm only		Water/ethylene glycol antifreeze			12 V nominal	
			Total: 7.5 L (2 gal) Radiator: 3.8 L (1 gal)			37 A alternator	
	Idle speed, no load		(Fast) governed speed, under load			Engine lubricating oil without filter	
	1350 ± 50 rpm		2800 ± 50 rpm			6 L (6.35 qt) API diesel classification CF or better	

M30 GENERAL MACHINE DIMENSIONS / SPECIFICATIONS - (CONTINUED)

M30 GENERAL MACHINE PERFORMANCE

Item	Measure
Minimum aisle turn	3175 mm (125 in)
Travel speed forward (maximum)	12.9 Km/h (8 mph)
Travel speed reverse (maximum)	4.8 Km/h (3 mph)
Maximum ramp incline for loading - Empty tanks	18%
Maximum ramp incline for scrubbing	10%
Maximum ramp incline for transporting (GVWR)	14%
Maximum ambient temperature for machine operation	43° C (110° F)
Minimum temperature for operating machine scrubbing functions	0° C (32° F)

M30 HYDRAULIC SYSTEM

System	Capacity	ISO Grade Viscosity Index	Ambient Air Temperature Ranges
Hydraulic reservoir	38 L (10 gal)	ISO 100 VI 126 or higher	19° C (65° F) or higher
Hydraulic total	45 L (12 gal)	ISO 68 VI 155 or higher	7 to 43° C (45 to 110° F)
		ISO 32 VI 163 or higher	16° C (60° F) or lower

M30 STEERING

Type	Power source
Front wheel, hydraulic cylinder and rotary valve controlled	Hydraulic accessory pump

M30 BRAKING SYSTEM

Type	Operation
Service brakes	Mechanical drum brakes (2), one per rear wheel, cable actuated
Parking brake	Utilize service brakes, cable actuated

M30 TIRES

Location	Type	Size
Front (1)	Solid	150 mm x 460 mm (6 in x 18 in)
Rear (2)	Solid	127 mm x 460 mm (5 in x 18 in)

M30 FaST SYSTEM

Item	Measure
Solution pump	12 Volt DC, 11A, 0.7 GPM & 1.4 GPM flow (2 speed), 75 psi high- pressure shutdown
Low solution flow rate	2.7 LPM (0.7 GPM)
High solution flow rate	5.4 LPM (1.4 GPM)
Low concentrate flow rate	2.6 CC/Minute (0.085 Liquid Ounces/Minute)
High concentrate flow rate	5.2 CC/Minute (0.17 Liquid Ounces/Minute)

SPECIFICATIONS

M30 GENERAL MACHINE DIMENSIONS / SPECIFICATIONS - (CONTINUED)

M30 *ec*-H2O SYSTEM

Item	Measure
Solution pump	12 Volt DC, 11A, 0.7 GPM & 1.4 GPM flow, (2 speeds), 75 psi high- pressure shutdown
Solution flow rate	2.65 LPM (0.7 GPM) - Low
	5.30 LPM (1.4 GPM) - High

M30 GENERAL MACHINE DIMENSIONS / SPECIFICATIONS - (CONTINUED)

M30 MACHINE DIMENSIONS

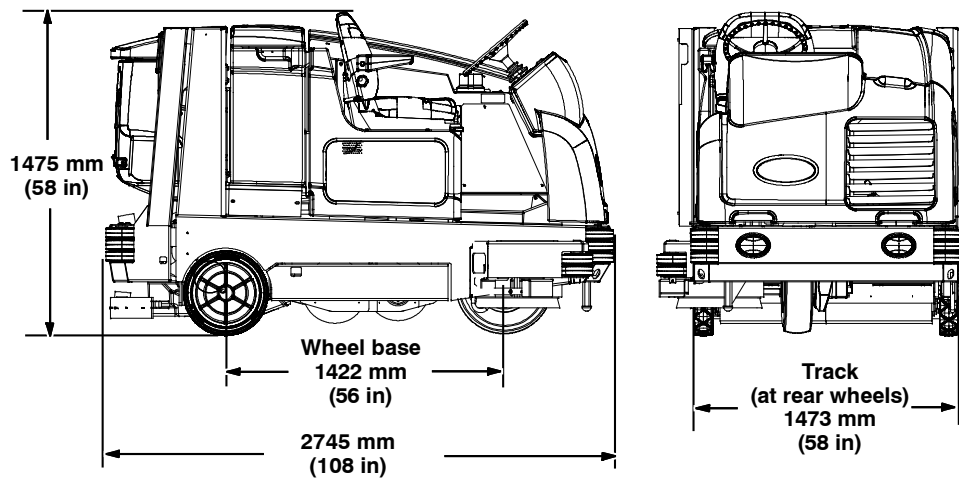
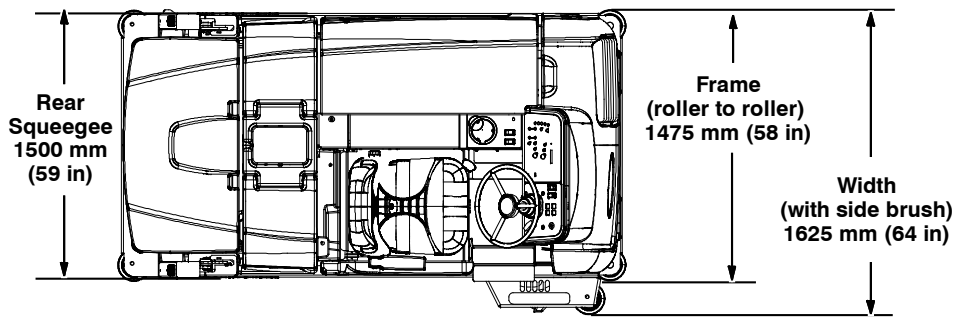

1014751

M20 GENERAL MACHINE DIMENSIONS / SPECIFICATIONS

M20 SPECIFICATIONS

M20 GENERAL MACHINE DIMENSIONS/CAPACITIES

Item	Dimension/capacity
Length	2410 mm (95 in)
Height	1470 mm (58 in)
Height (with overhead guard)	2120 mm (83.5 in)
Width/frame (roller to roller)	1270 mm (50 in)
Width (rear squeegee)	1300 mm (51 in)
Width (with side brush)	1470 mm (58 in)
Wheel base	1280 mm (50.38 in)
Track	1270 mm (50 in)
Cleaning path width (Main brush length)	1020 mm (40 in)
Cleaning path width (with scrubbing side brush)	1370 mm (54 in)
Cleaning path width (with sweeping side brush)	1420 mm (56 in)
Main brush diameter (2)	300 mm (12 in)
Side brush diameter (scrubbing)	410 mm (16 in)
Side brush diameter (sweeping)	530 mm (21 in)
Solution tank capacity	212 L (56 gallons)
Recovery tank capacity	276 L (73 gallons)
Debris hopper volume capacity	110 L (3.9 ft ³)
Debris hopper weight capacity	177 kg (390 lbs)
Dump height (variable to)	1520 mm (60 in)
Minimum ceiling dump height	2500 mm (98 in)
Weight - empty	1497 Kg (3300 lbs)
GVMR	2359 Kg (5200 lbs)
Transport ground clearance	80 mm (3 in)
Protection Grade	IPX3

Values determined as per IEC 60335- 2- 72	Measure
Sound pressure level L_{pA}	84 dB(A)
Sound uncertainty K_{pA}	3.0 dB(A)
Sound power level L_{WA} + Uncertainty K_{WA}	106 dB(A)
Vibration - Hand- arm	< 2.5 m/s ²
Vibration - Whole body	< 0.5 m/s ²

M20 GENERAL MACHINE DIMENSIONS / SPECIFICATIONS - (CONTINUED)

M20 GENERAL MACHINE PERFORMANCE

Item	Measure
Minimum aisle turn	2790 mm (110 in)
Travel speed forward (maximum)	12.9 Km/h (8 mph)
Travel speed reverse (maximum)	4.8 Km/h (3 mph)
Maximum ramp incline for loading - Empty tanks	18%
Maximum ramp incline for scrubbing	14%
Maximum ramp incline for transporting (GVWR)	18%
Maximum ambient temperature for machine operation	43° C (110° F)
Minimum temperature for operating machine scrubbing functions	0° C (32° F)

SPECIFICATIONS

M20 GENERAL MACHINE DIMENSIONS / SPECIFICATIONS - (CONTINUED)

M20 HYDRAULIC SYSTEM

System	Capacity	ISO Grade Viscosity Index	Ambient Air Temperature Ranges
Hydraulic reservoir	38 L (10 gal)	ISO 100 VI 126 or higher	19° C (65° F) or higher
Hydraulic total	45 L (12 gal)	ISO 68 VI 155 or higher	7 to 43° C (45 to 110° F)
		ISO 32 VI 163 or higher	16° C (60° F) or lower

M20 POWER TYPE

Engine	Type	Ignition	Cycle	Aspiration	Cylinders	Bore	Stroke
Mitsubishi 2.0	Piston	Coil @ Plug	4	Natural	4	85 mm (3.35 in)	88 mm (3.46 in)
	Displacement		Tennant governed power			Gross intermittent power per SAE J1995	
	2.0 L (122 cu in)		37.3 kw (50 hp) @ 2300 rpm			44.7 kw (60 hp) @ 3000 rpm	
	Fuel		Cooling system			Electrical system	
	Gasoline, 87 octane minimum, unleaded Fuel tank: 42 L (11.2 gal)		Water/ethylene glycol antifreeze			12 V nominal	
	LPG, Fuel tank: 15 kg (33 lb)		Total: 7.5 L (2 gal) Radiator: 3.8 L (1 gal)			75 A alternator	
	Idle speed, no load		(Fast) governed speed, under load			Firing order	
	1350 ± 50 rpm		2300 ± 50 rpm			1-3-4-2	
	Spark plug gap		Valve clearance, cold			Engine lubricating oil with filter	
	1.1 mm (0.043 in)		No Adjustment OHC Engine			4.7 L (5 qt) 5W30 SAE- SG/SH	

Engine	Type	Ignition	Cycle	Aspiration	Cylinders	Bore	Stroke
Kubota V1505- B	Piston	Diesel	4	Natural	4	78 mm (3.07 in)	78.4 mm (3.09 in)
	Displacement		Tennant governed power			Gross intermittent power per SAE J1995	
	1500 cc (91.4 cu in)		18.5 kw (24.8 hp) @ 2300 rpm			18.5 kw (24.8 hp) @ 2300 rpm	
	Fuel		Cooling system			Electrical system	
	Diesel Fuel tank: 42 L (11.2 gal) low sulfur fuel content less than 500ppm only		Water/ethylene glycol antifreeze			12 V nominal	
			Total: 7.5 L (2 gal) Radiator: 3.8 L (1 gal)			37 A alternator	
	Idle speed, no load		(Fast) governed speed, under load			Engine lubricating oil without filter	
	950 ± 50 rpm		2400 ± 50 rpm			6 L (6.35 qt) diesel classification CF or better	

M20 GENERAL MACHINE DIMENSIONS / SPECIFICATIONS - (CONTINUED)

M20 BRAKING SYSTEM

Type	Operation
Service brakes	Mechanical drum brakes (2), one per rear wheel, cable actuated
Parking brake	Utilize service brakes, cable actuated

M20 TIRES

Location	Type	Size
Front (1)	Solid	140 mm x 460 mm (5.5 in x 18 in)
Rear (2)	Solid	90 mm x 410 mm (3.5 in x 16 in)

M20 STEERING

Type	Power source
Front wheel, hydraulic cylinder, and rotary valve controlled	Hydraulic accessory pump

M20 FaST SYSTEM

Item	Measure
Solution pump	12 Volt DC, 11A, 0.7 GPM & 1.4 GPM flow, (2 speeds), 75 psi high- pressure shutdown
Low solution flow rate	2.7 LPM (0.7 GPM)
High solution flow rate	5.4 LPM (1.4 GPM)
Low concentrate flow rate	2.6 CC/Minute (0.085 Liquid Ounces/Minute)
High concentrate flow rate	5.2 CC/Minute (0.17 Liquid Ounces/Minute)

M20 ec-H2O SYSTEM

Item	Measure
Solution pump	12 Volt DC, 11A, 0.7 GPM & 1.4 GPM flow, (2 speeds), 75 psi high- pressure shutdown
Solution flow rate	2.65 LPM (0.7 GPM) - Low
	5.30 LPM (1.4 GPM) - High

SPECIFICATIONS

M20 GENERAL MACHINE DIMENSIONS / SPECIFICATIONS - (CONTINUED)

M20 MACHINE DIMENSIONS

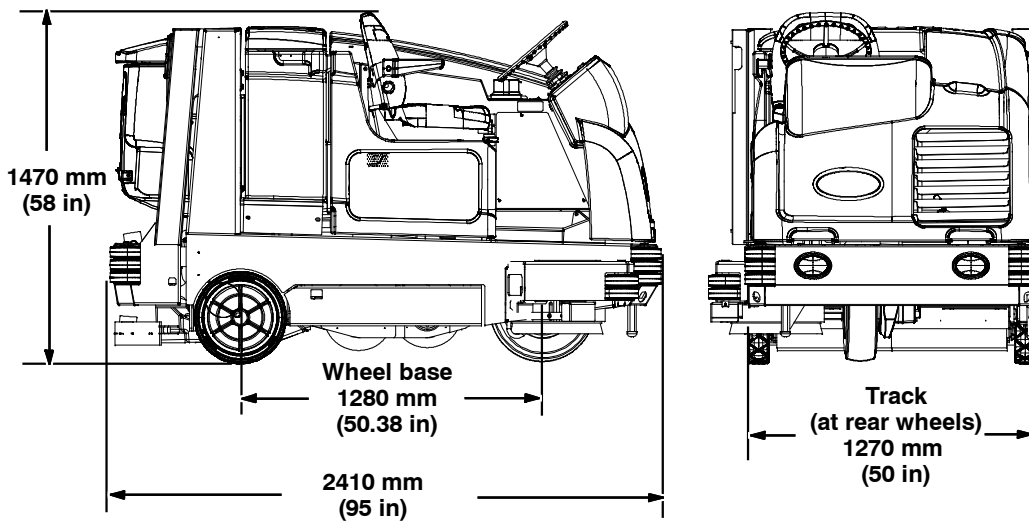
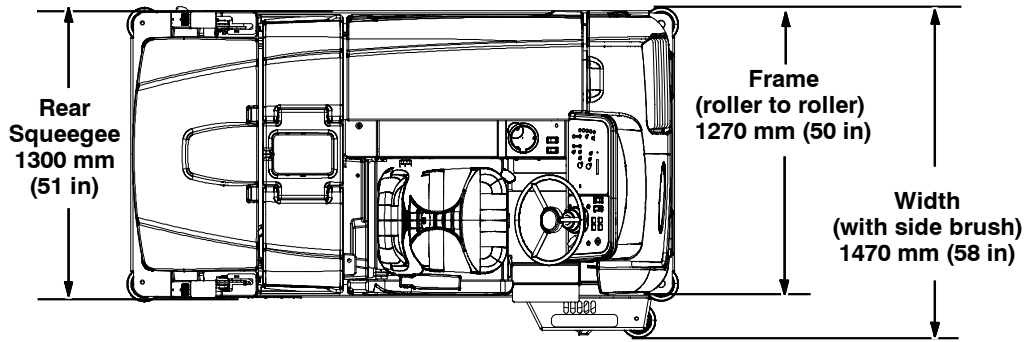

1014751

ELECTRICAL COMPONENT LOCATOR

M SERIES ELECTRICAL COMPONENT LOCATOR



Shaker Motor



Hopper Latch
Solenoid SOL-9

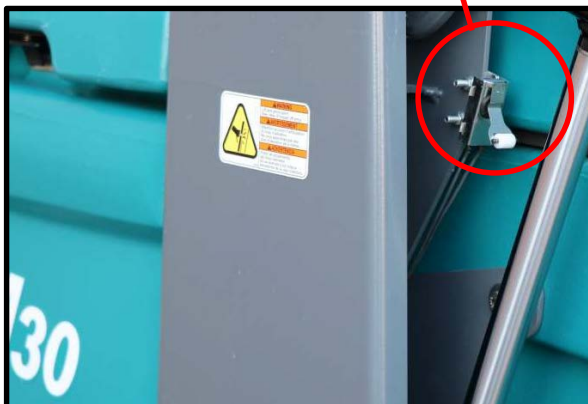
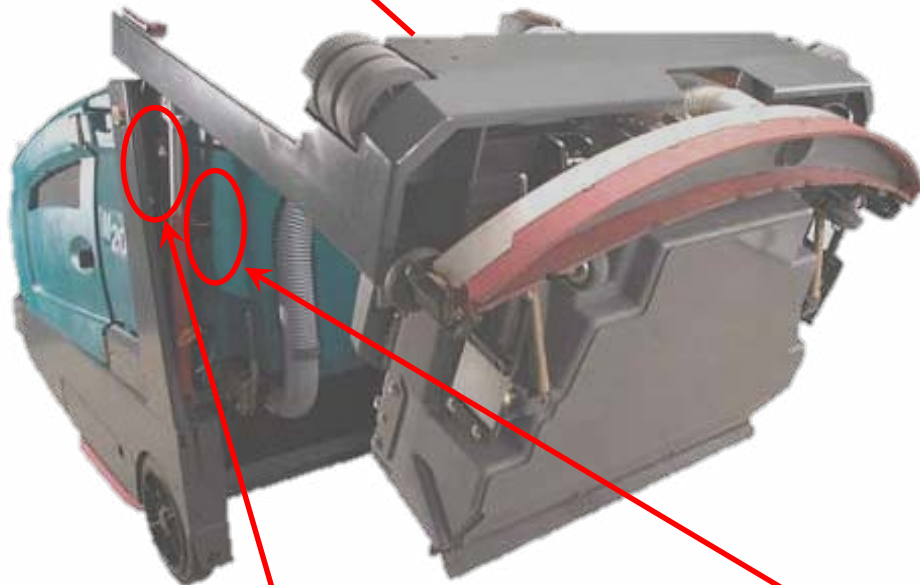

Hopper Down
Sense Switch



Recovery Tank
Full Switch S-15

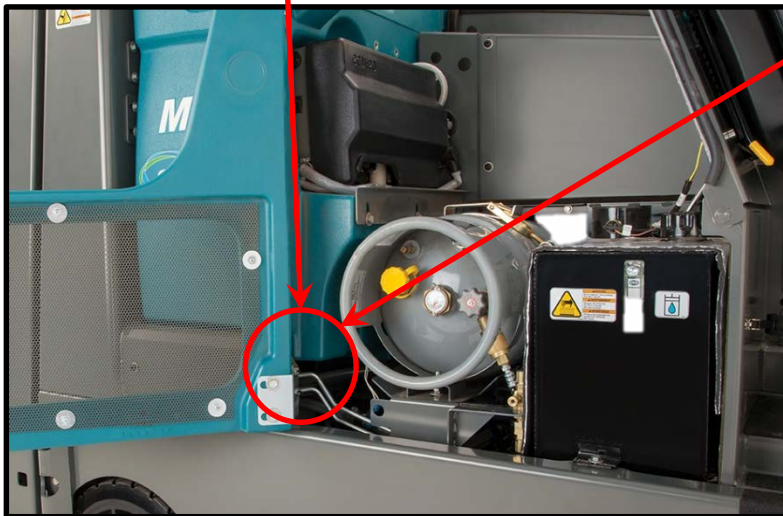
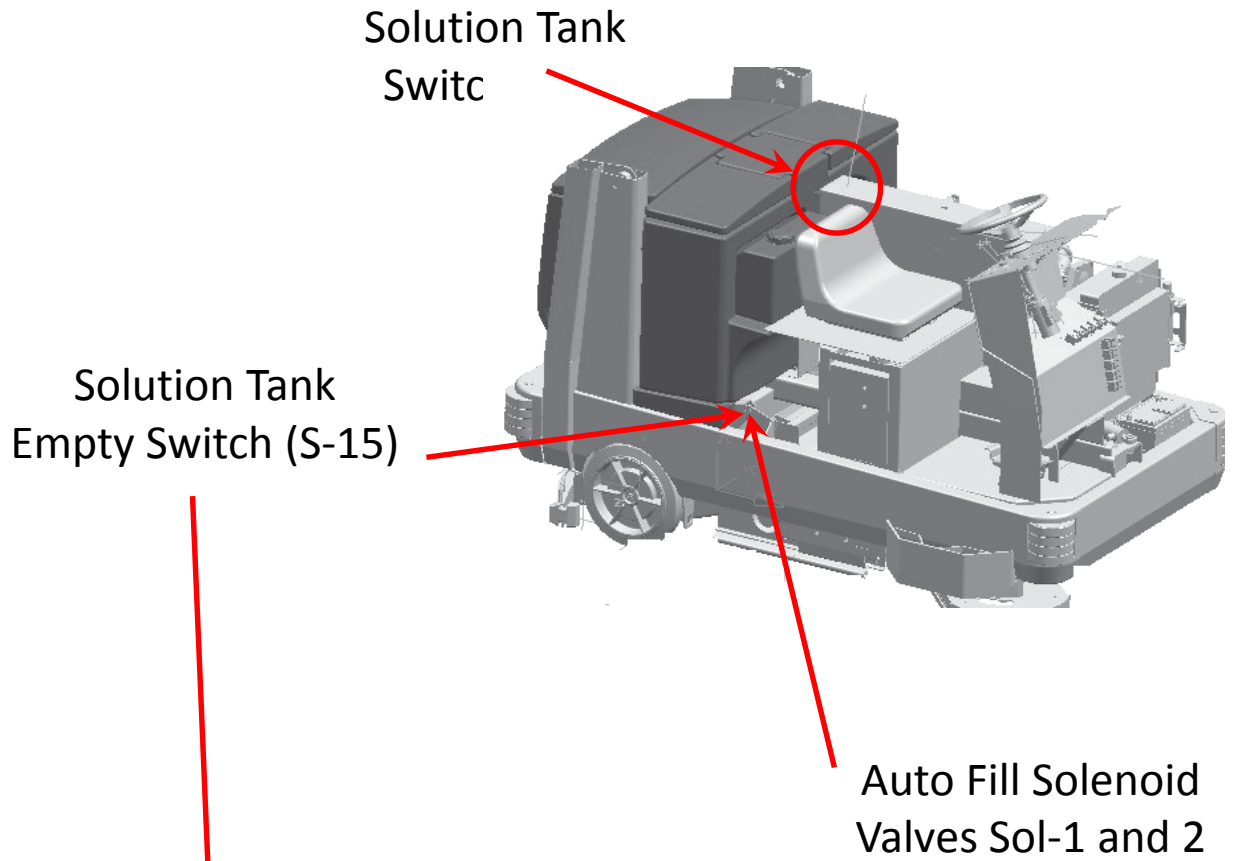

M SERIES ELECTRICAL COMPONENT LOCATOR - (CONTINUED)

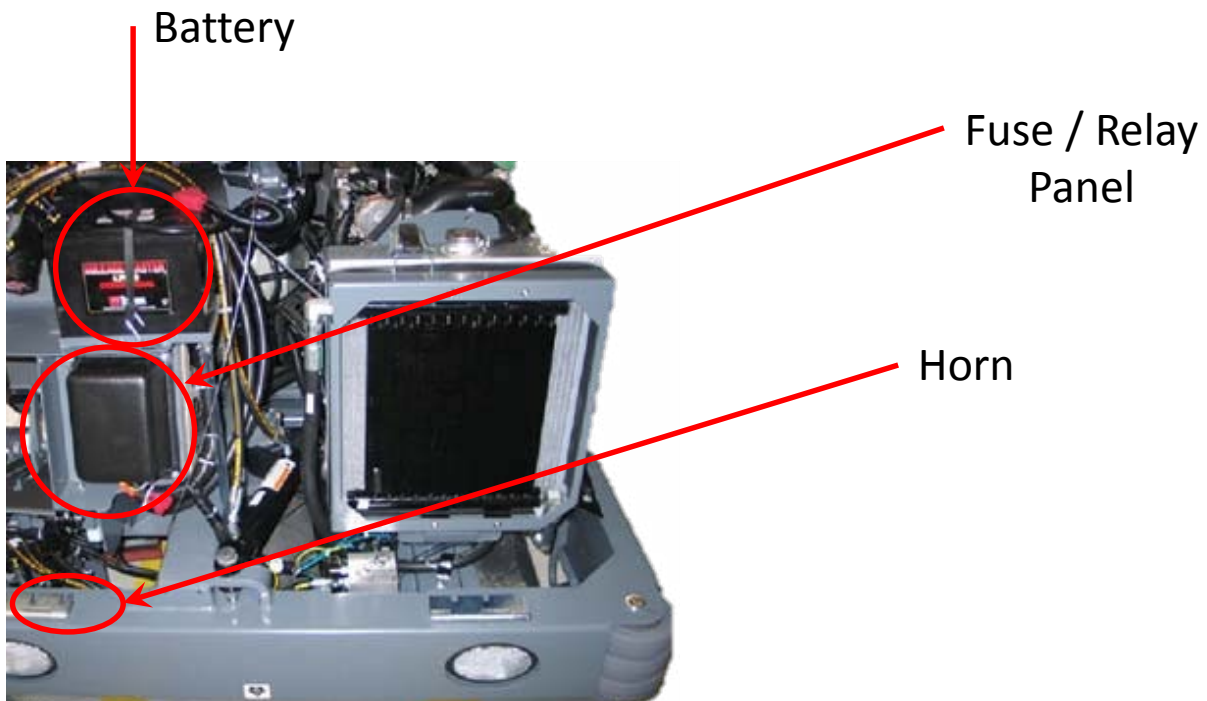

ES Equipped Machines

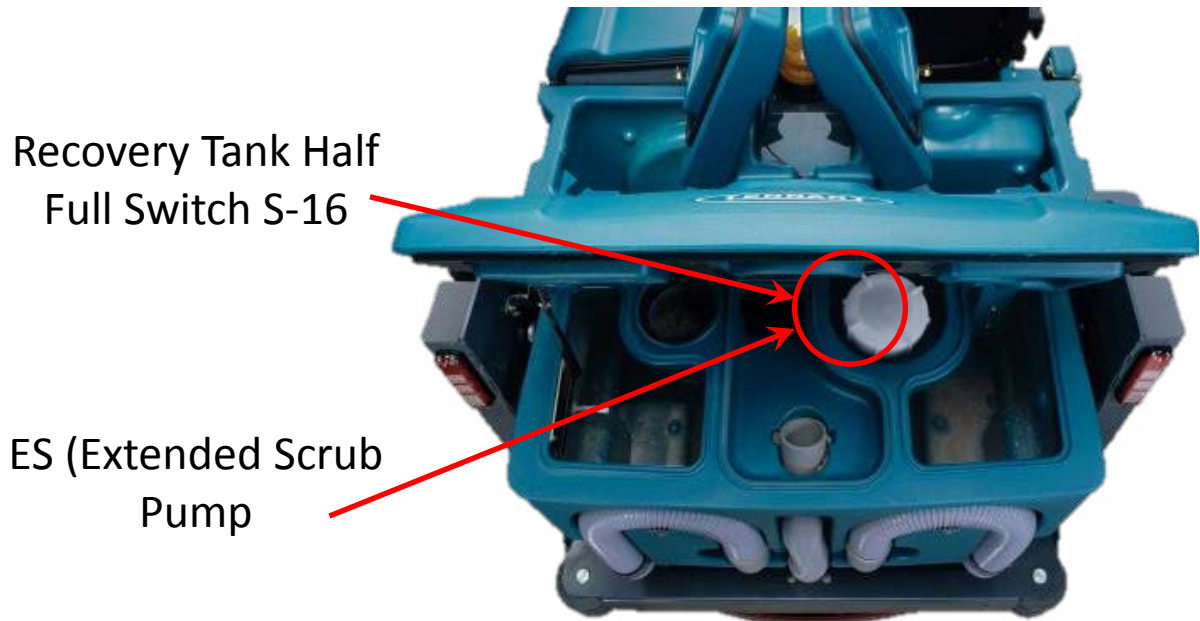

Shaker Motor

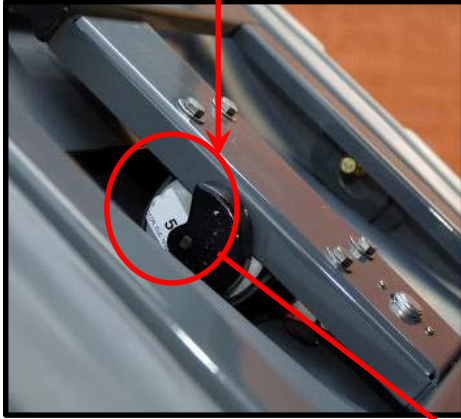

Hopper Thermal Sentry Switch S-9

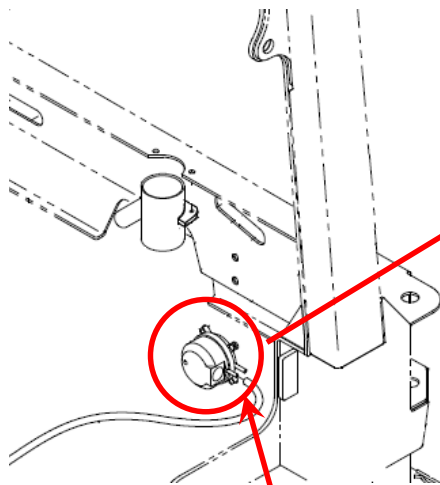
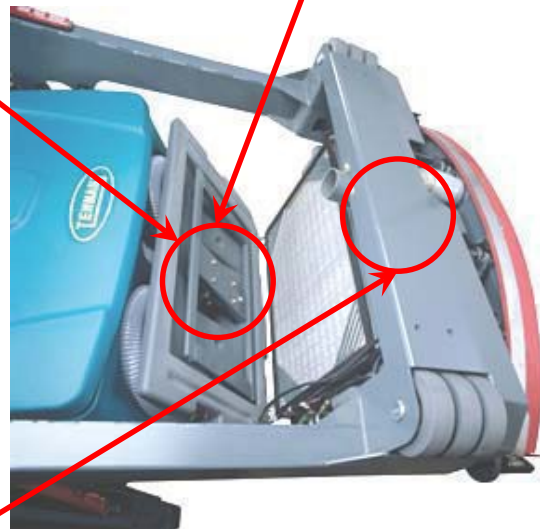
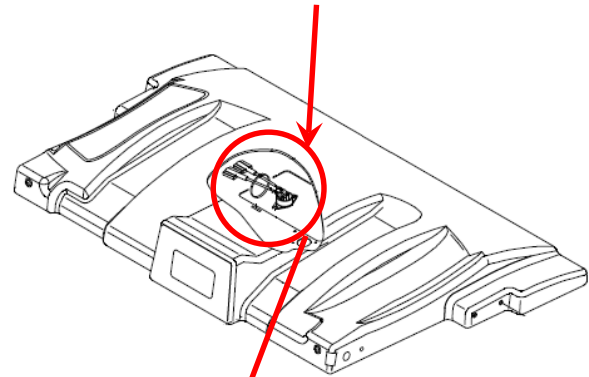

Sweeper Filter Clogged Switch S-18
(Viewed Behind Bumper)

M SERIES ELECTRICAL COMPONENT LOCATOR - (CONTINUED)

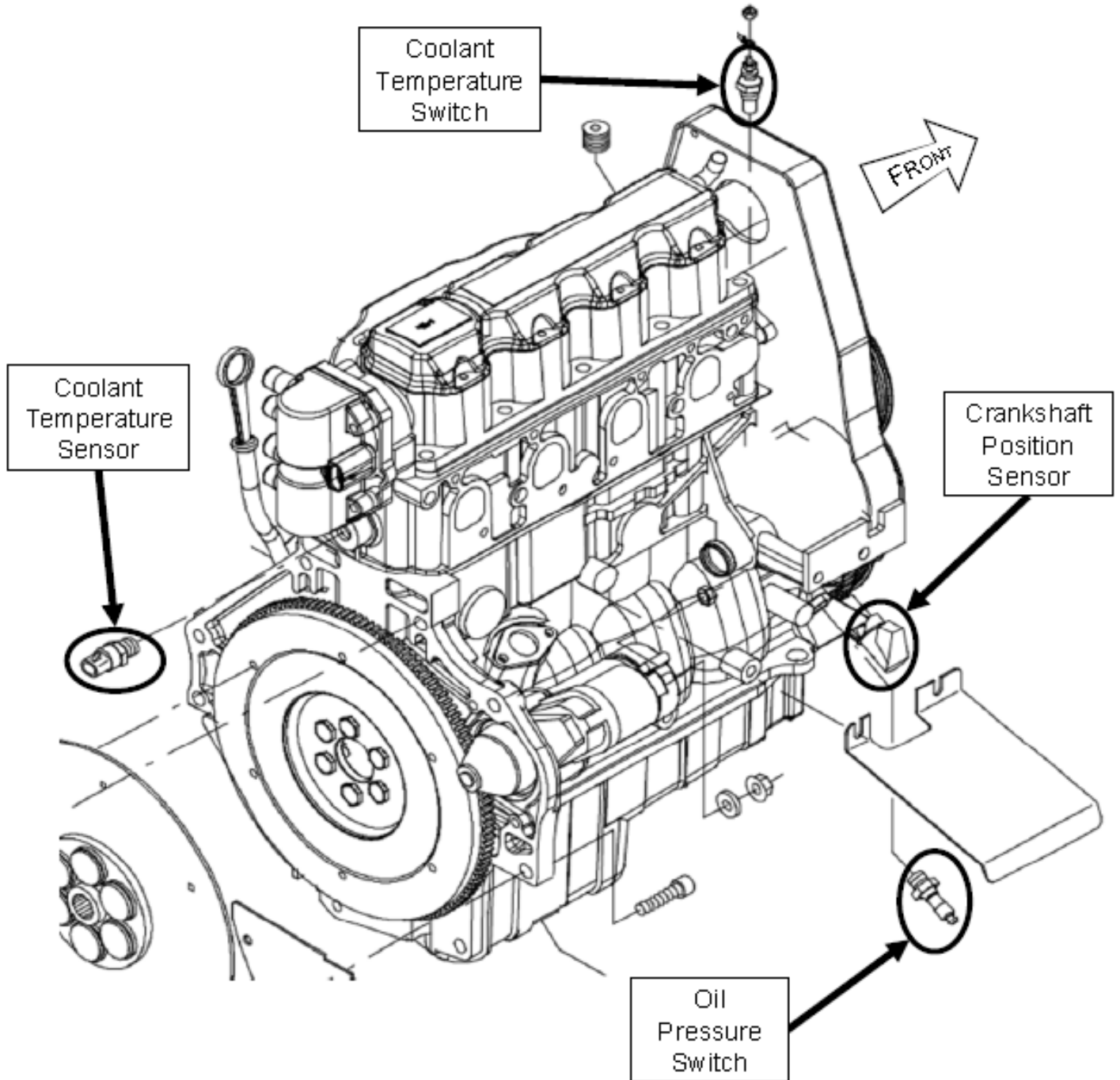

ELECTRICAL COMPONENT LOCATOR

M SERIES ELECTRICAL COMPONENT LOCATOR - (CONTINUED)

Back of Engine

Cam Sensor

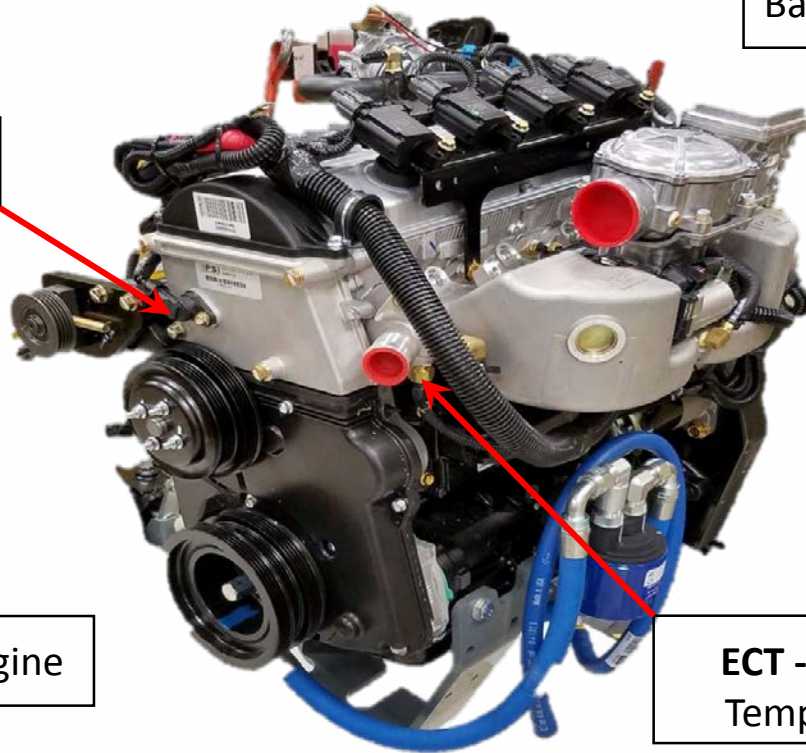

Front of Engine

ECT - Engine Coolant Temperature Sensor

Front of Engine

CKP
Crank Position Sensor

ECM / ECU
Engine Control Module
or module

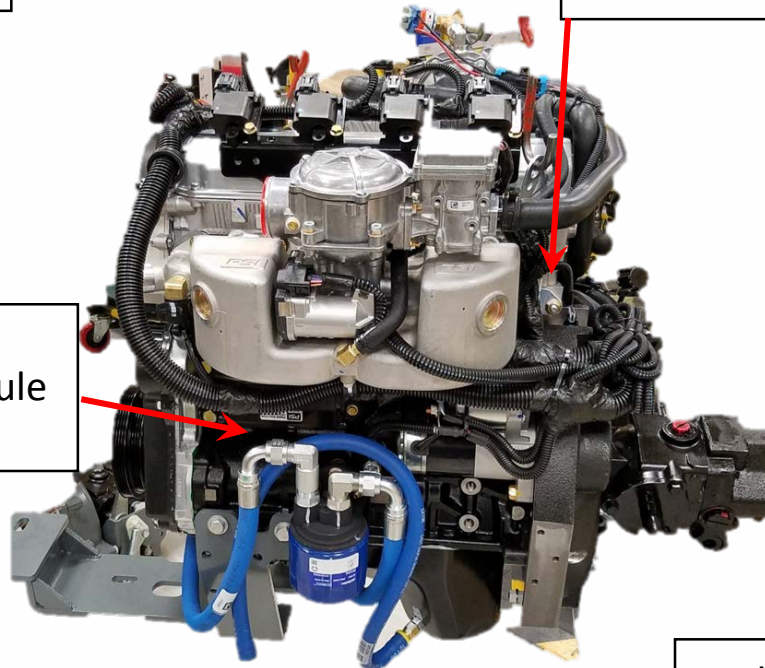

Back of Engine

M SERIES ELECTRICAL COMPONENT LOCATOR - (CONTINUED)

Back of Engine

CAM Sensor

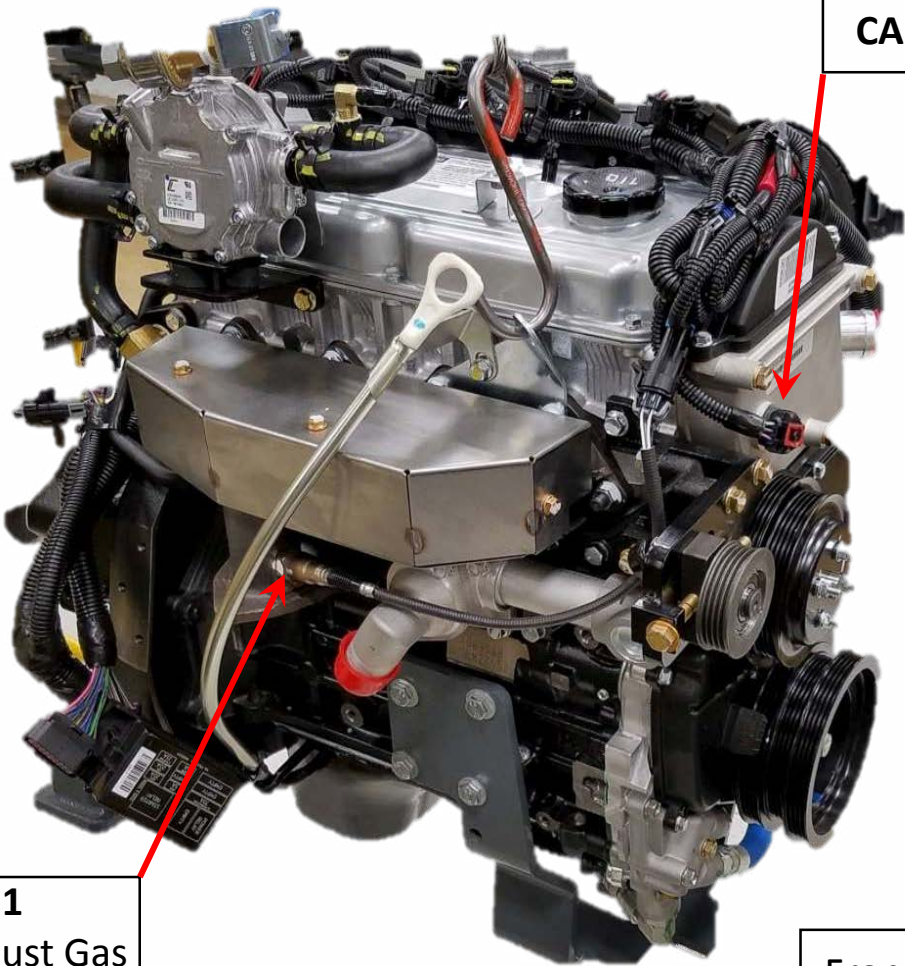

HEGO 1
Heated Exhaust Gas
Oxygen Sensor

Front of Engine

ELECTRICAL COMPONENT LOCATOR

M SERIES ELECTRICAL COMPONENT LOCATOR - (CONTINUED)

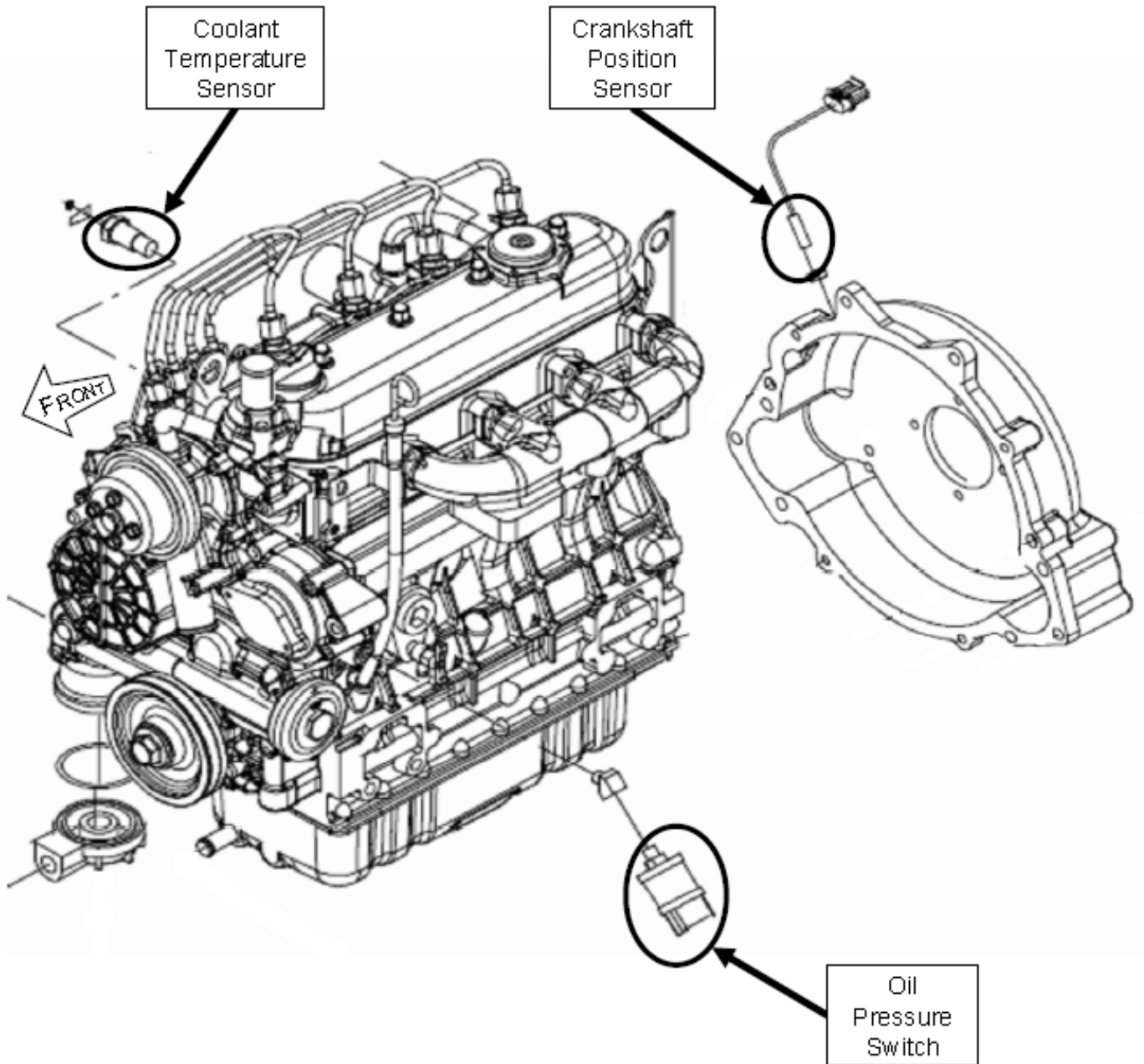

M SERIES ELECTRICAL COMPONENT LOCATOR - (CONTINUED)

Side Brush Motor



Sweep Fan Motor

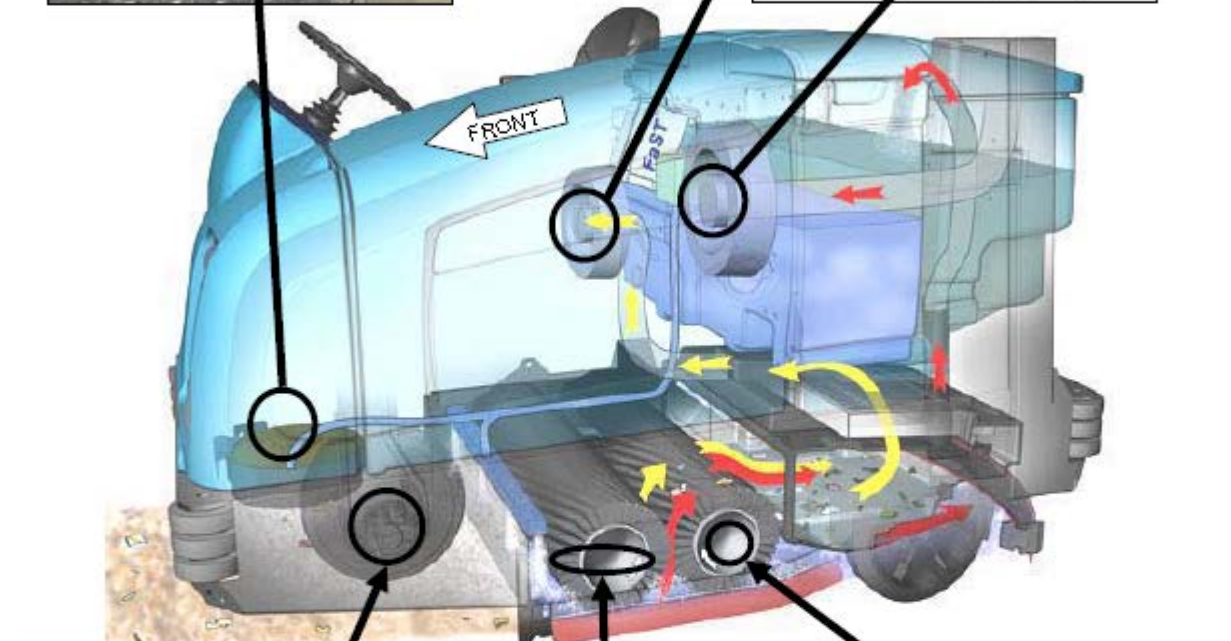
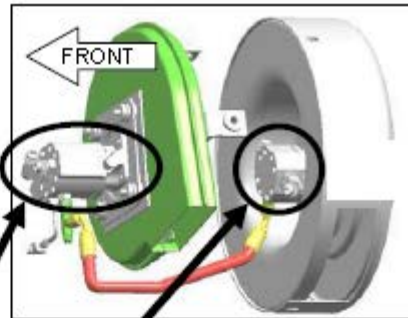

Propel Motor

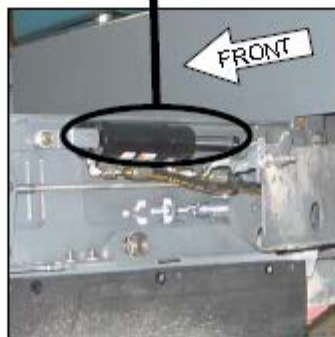

Left Side Squeegee

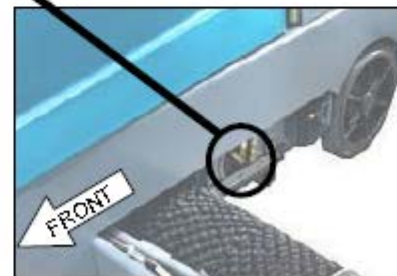

Main Brush Motor (Rear)

Hopper Lift Cylinder



Scrub Head Lift Cylinder

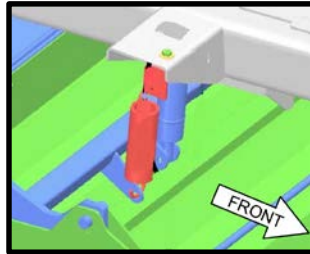

Side Brush Extend Cylinder

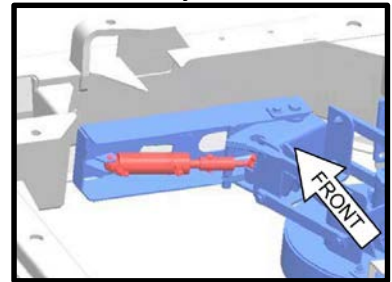

Right Side Squeegee Lift Cylinder



Main Brush Motor (Front)

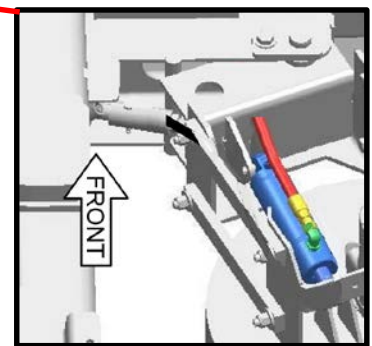

Side Brush Cylinder

M SERIES ELECTRICAL COMPONENT LOCATOR - (CONTINUED)



Hopper Door Cylinder



Side Brush Manifold
SV-8, SV-10, SV-11,
SV-12, PR-1, PR-12, PC-8

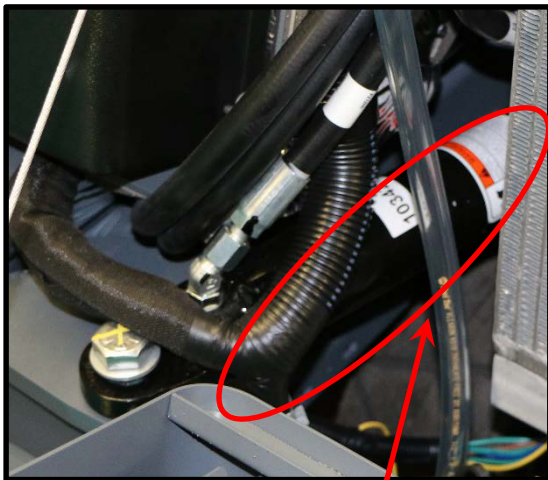

Steering Cylinder

Rear Squeegee Lift Cylinder
(Viewed Behind Bumper)



Hydraulic Valve SV-1, SV-2, SV-3, SV-4, SV-6, SVC-7, SV-13A,
SVC-14B, SV-15 RV-1, RV-2, OR-1, OR-4, CV-1, PC-1, PC-2,
PC-5, PC-6, PCV-7, G-1, G-2, G-5, G-6, G-11, C-11

Sweep Fan Valve SV-9

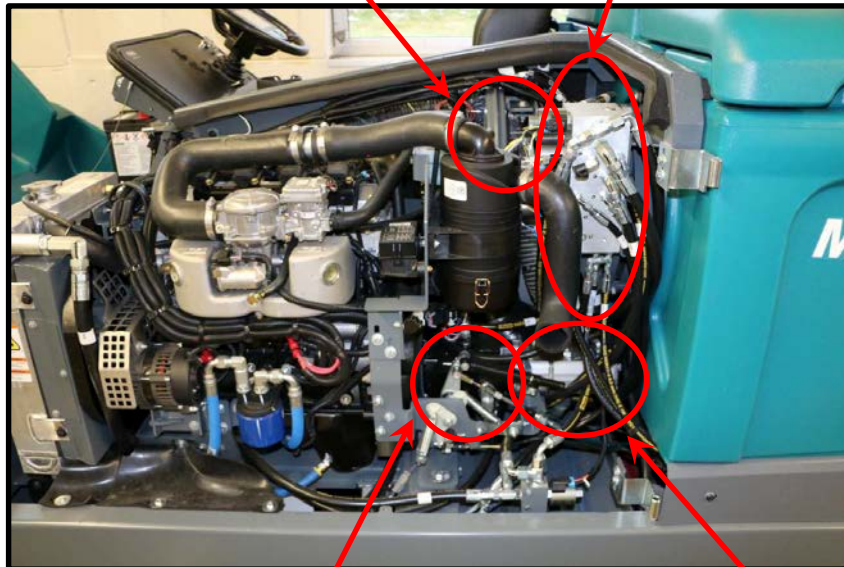

Propel Pump

Accessory Pumps

M SERIES ELECTRICAL COMPONENT LOCATOR - (CONTINUED)

P/N #1072995

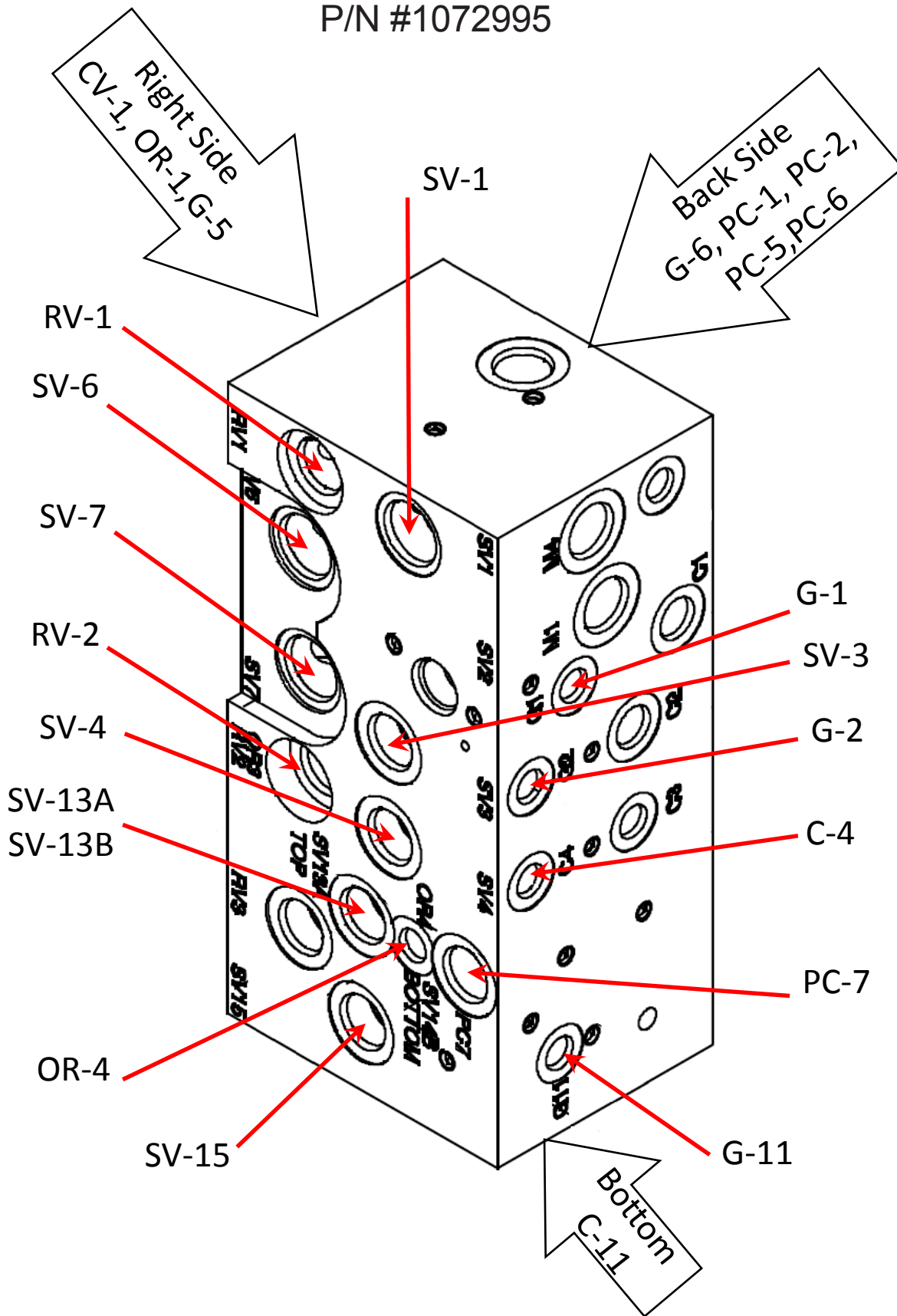

P/N #1072997

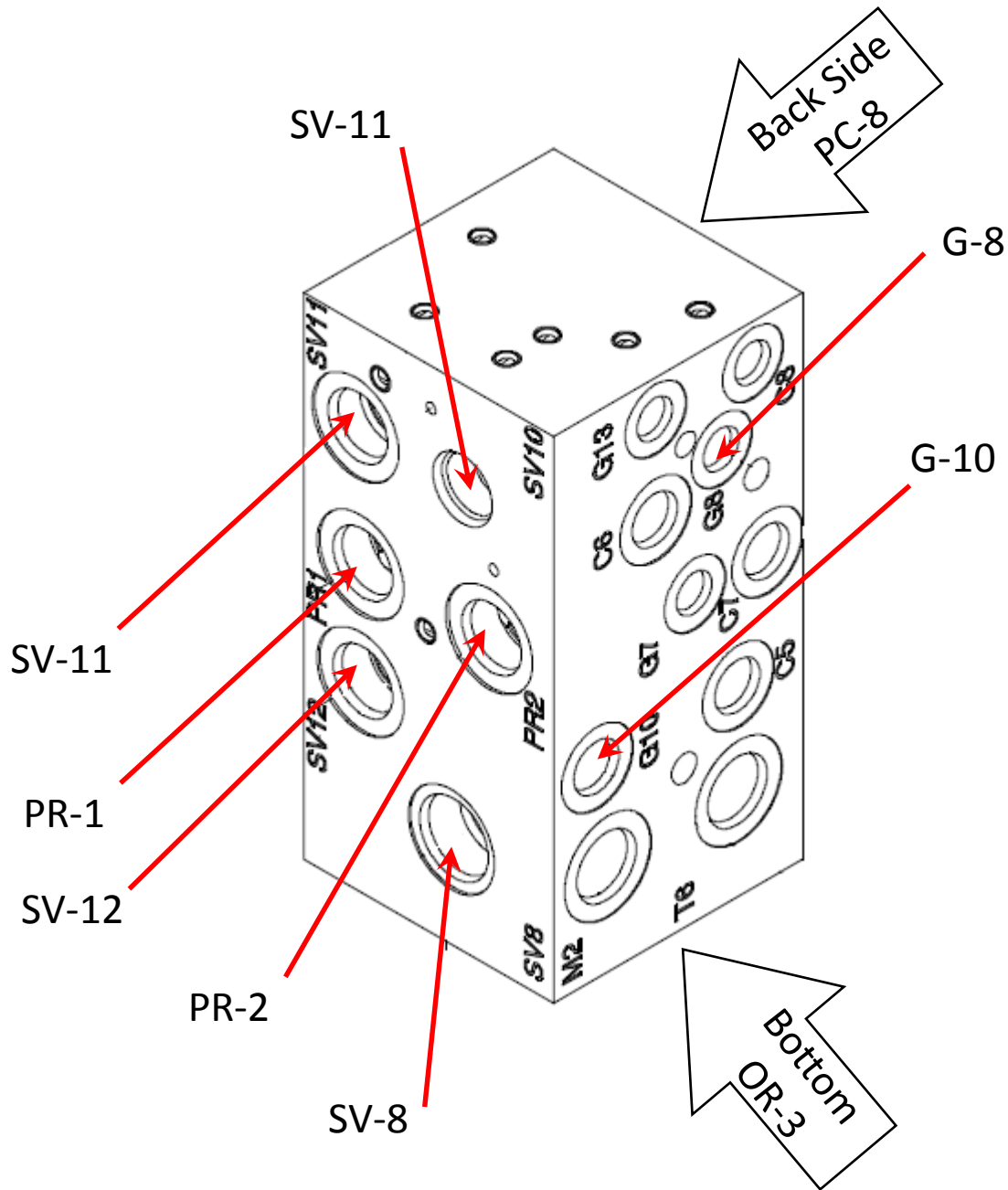



M-Series Electrical

ELECTRICAL

Troubleshooting Information

BEFORE CONDUCTING TESTS:

- *Read and Follow *ALL* Safety Warnings and Precautions as mentioned at the beginning of this manual.
- *Always use an ESD (Electrostatic Discharge) strap when working near the Control Board.
- *Be cautious when working near Control Board – *Battery voltage is always present, even with Key OFF.*
- * Always dis-connect Battery when removing or replacing components.

DURING TESTS:

- * Call Technical Services if Diagnostic Time Exceeds One Hour With Unknown Cause or Course of Action.

NOTE: Troubleshooting charts may be shown with optional equipment. The optional equipment may not be specified in these charts. Some machines may not be equipped with all components shown.

ELECTRICAL SCHEMATIC SYMBOLS

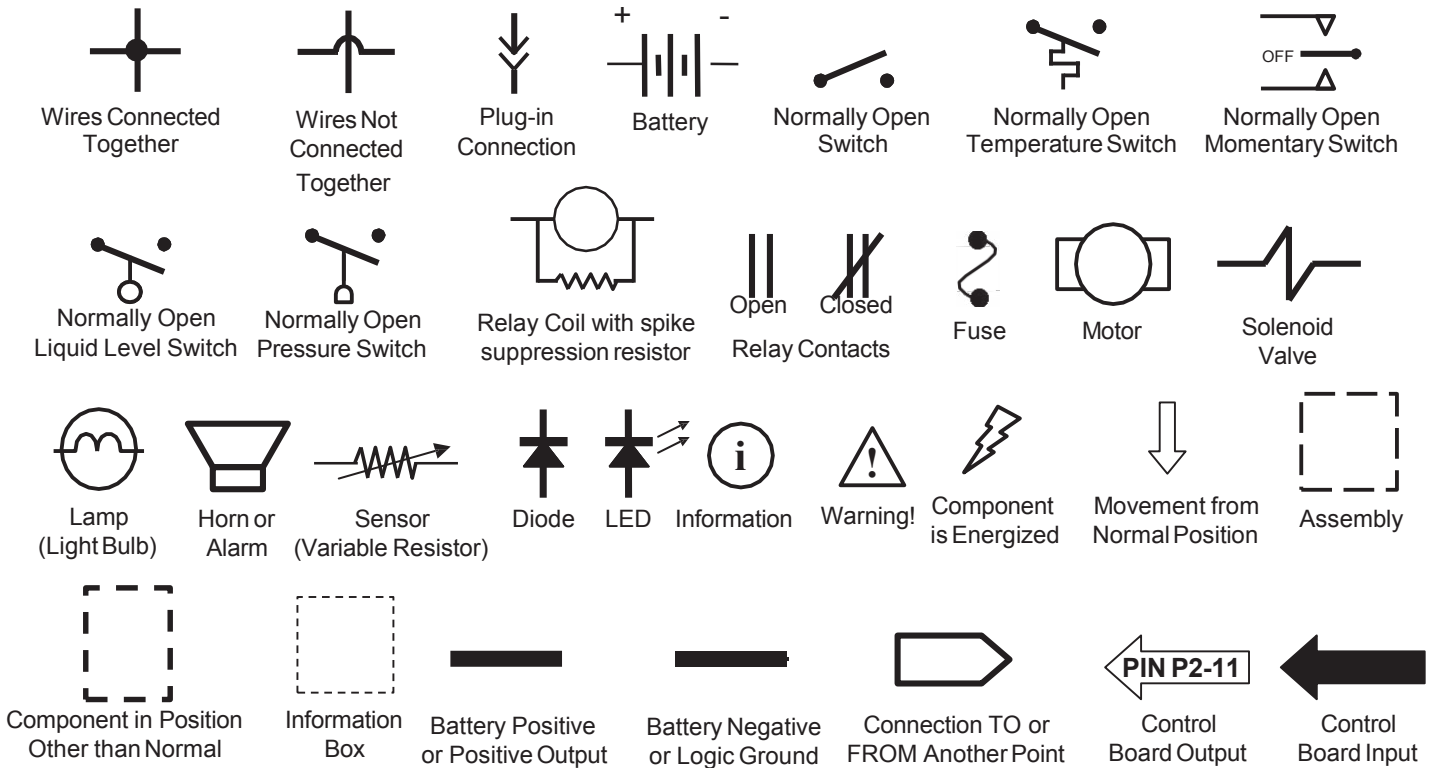

Terms & Abbreviations

ECM – Engine Control Module

LED – Light Emitting Diode

MIL – Malfunction Indicator Lamp

PWM – Pulse Width Modulation (A method of using controlled on/off times to regulate the voltage and current supplied to an electrical device)

SV – Solenoid Valve

SW – Switch

Example of Wiring Numbers & Colors:

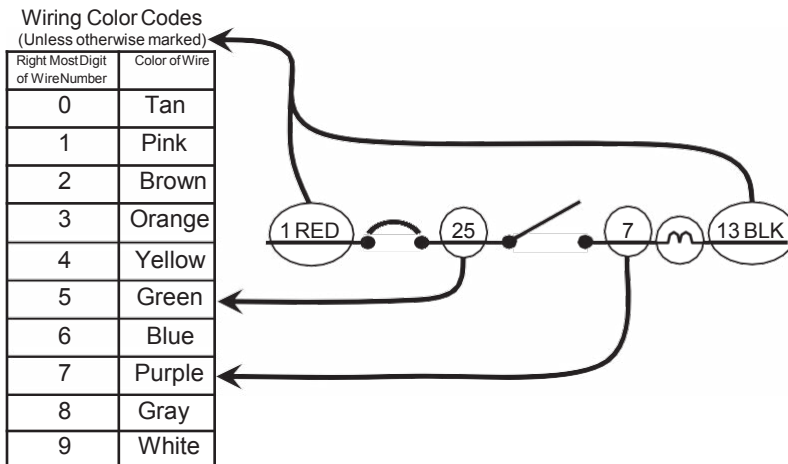

ELECTRICAL OPTION COMPONENTS

The following chart lists various options and the electrical and/or hydraulic components that are associated with the option. Refer to the “notes” section for any components that are deleted from a standard machine in order to have the installed option.

option	added components	E or H	component #	notes
Side Brush	Side Brush ON Solenoid Valve	E,H	SV-8	
	Side Brush Pressure Solenoid Valve	E,H	SV-10	
	Side Brush Down Solenoid Valve	E,H	SV-11	
	Side Brush Extend Solenoid Valve	E,H	SV-12	
	FaST Side Brush Valve	E	SOL-6	
	Side Brush Water Valve	E	SOL-7	
	Side Brush Manifold	H	x	
	Side Brush Lift Cylinder	H	x	
	Side Brush Extend Cylinder	H	x	
	Side Brush Motor	H	x	
ES (Extended Scrub)	Solution Tank Auto Fill Water Valve	E	SOL-1	If machine has ES option, the following components will not be on the machine: FaST Water Pump, FaST Water Pump Relay (M11), FaST Detergent Pump, FaST Air Pump, FaST Enable Valve (SOL-4), FaST High Flow Valve (SOL-5), FaST Side Brush Valve (SOL-6)
	Recovery Tank Auto Fill Water Valve	E	SOL-2	
	Solution Tank Full Switch	E	S-14	
	Recovery Tank Half Full Switch	E	S-16	
	Detergent Pump	E	x	
	ES Pump	E	x	
Spray Hose	Spray Hose Pump	E	x	
	Spray Hose Relay	E	M12	
	Spray Hose Switch	E	S-25	

E = Electrical Component
H = Hydraulic Component

Key Power Distribution

Conditions: Glow Plug, Key Off, Run, Start Positions

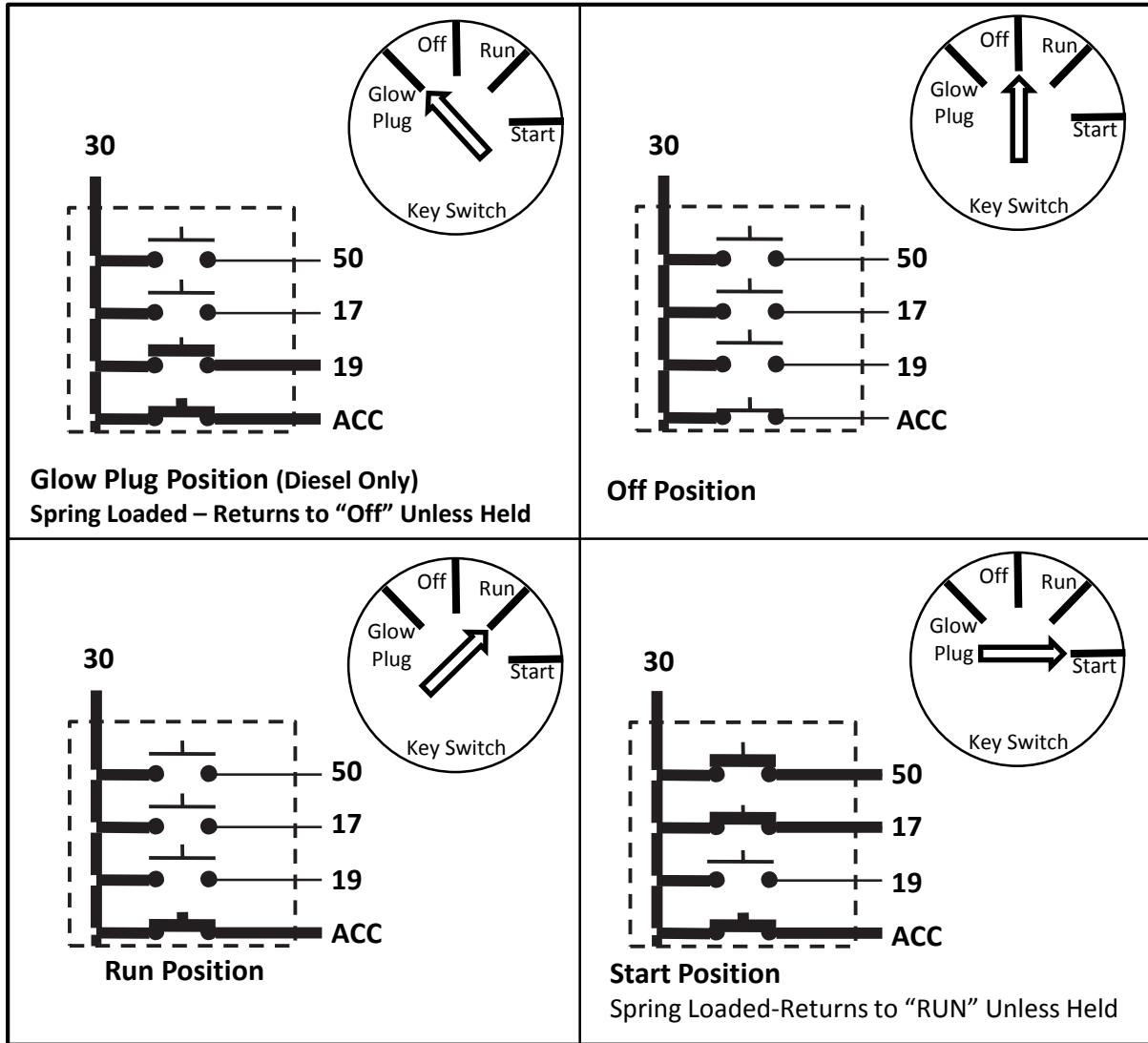

Switch Terminal Markings

KEY SWITCH POSITION		30	50	17	19	ACC
	GLOW PLUG	●			●	●
	OFF	NO CONNECTIONS				
	RUN	●				●
	START	●	●	●		●

i ● — ● Indicates a common connection

i Common connections in various switch positions should be less than one (1) ohm resistance.

Key Power Distribution

Conditions: Key Off

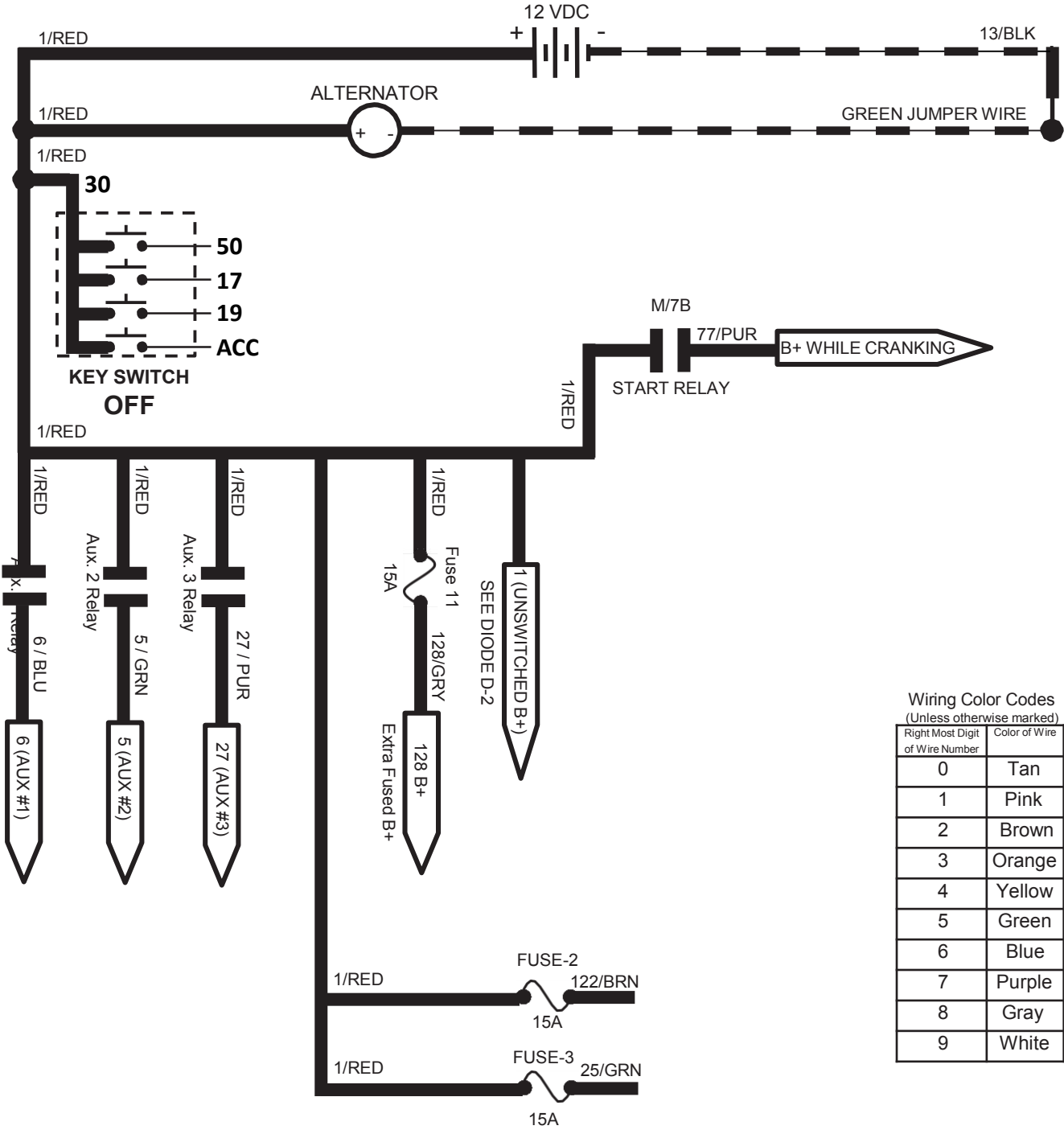

Wiring Color Codes
(Unless otherwise marked)

Right Most Digit of Wire Number	Color of Wire
0	Tan
1	Pink
2	Brown
3	Orange
4	Yellow
5	Green
6	Blue
7	Purple
8	Gray
9	White

 **Be cautious when working near Control Board - Battery voltage is always present, even with Key OFF**

 **Pin P2-3 supplies power to the on-board clock only. Disconnecting battery, removing Fuse 10, or removing connector P2 from Control Board will require the clock to be reset.**

ELECTRICAL

Key On Power Distribution

Conditions: Key On Engine Off

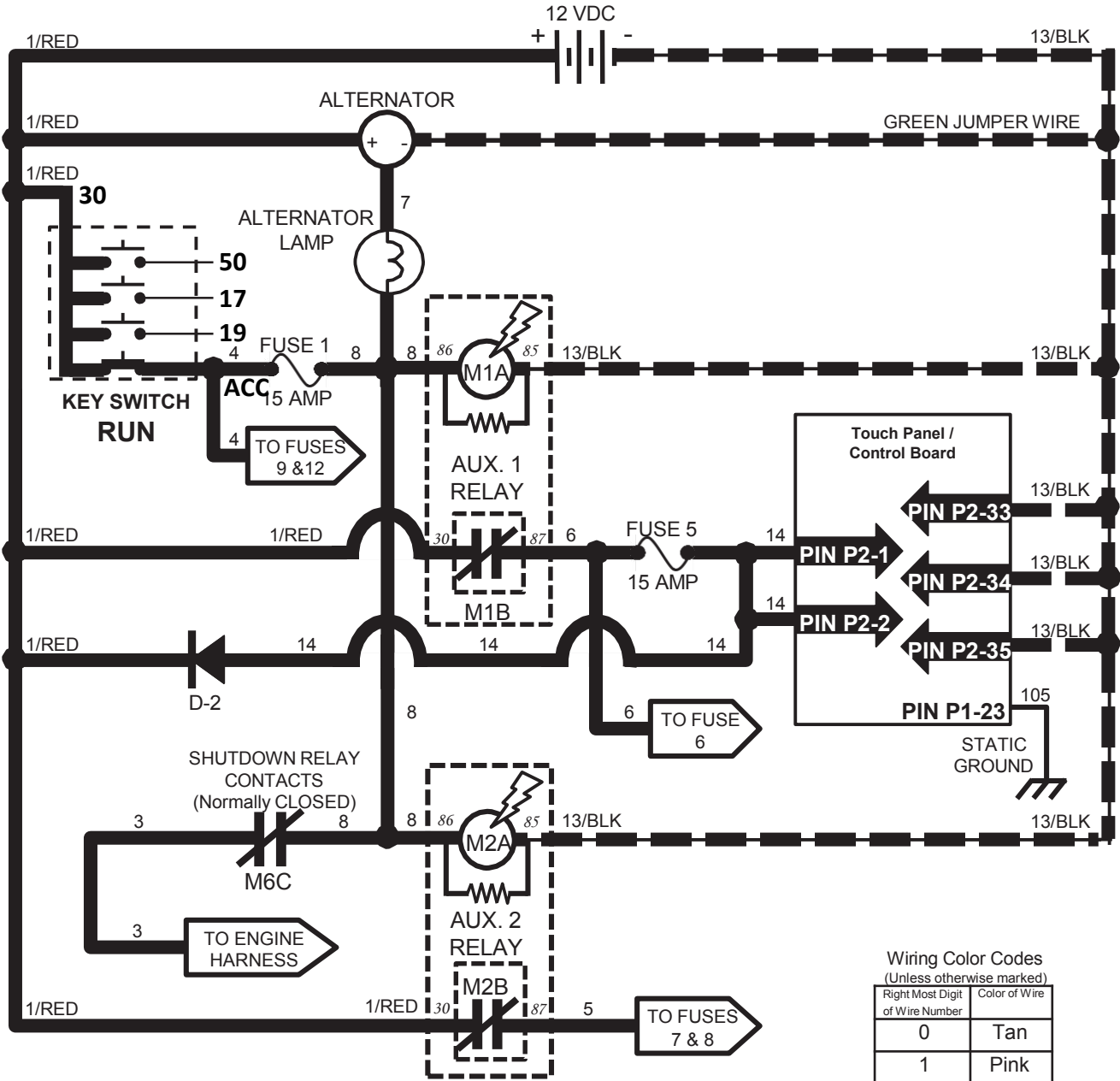

Wiring Color Codes
(Unless otherwise marked)

Right Most Digit of Wire Number	Color of Wire
0	Tan
1	Pink
2	Brown
3	Orange
4	Yellow
5	Green
6	Blue
7	Purple
8	Gray
9	White

Main Brushes On

Conditions: Key On, Engine Running, Scrubbing or Sweeping System On Propelling

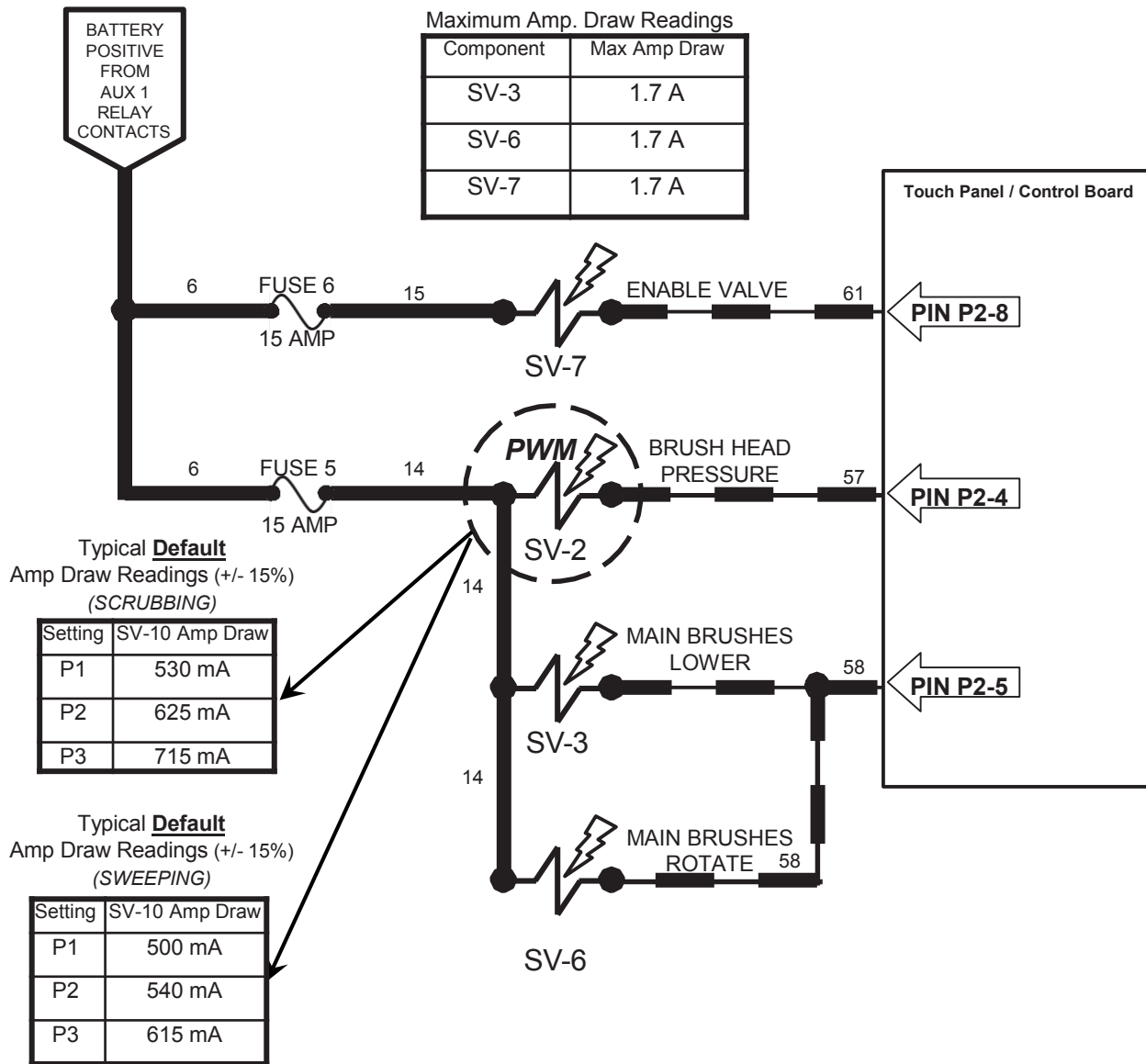

Wiring Color Codes
(Unless otherwise marked)

Right Most Digit of Wire Number	Color of Wire
0	Tan
1	Pink
2	Brown
3	Orange
4	Yellow
5	Green
6	Blue
7	Purple
8	Gray
9	White

i Pressure settings P1, P2, & P3 are the Touch Panel LED indicators for Brush down pressure.

i SV-2 is controlled by PWM; a higher duty cycle (more Brush Pressure LED's lit on Touch Panel) will result in more brush down pressure.

ELECTRICAL

Hopper Lift

Conditions: Key On Engine Running, Hopper Lift Switch Activated

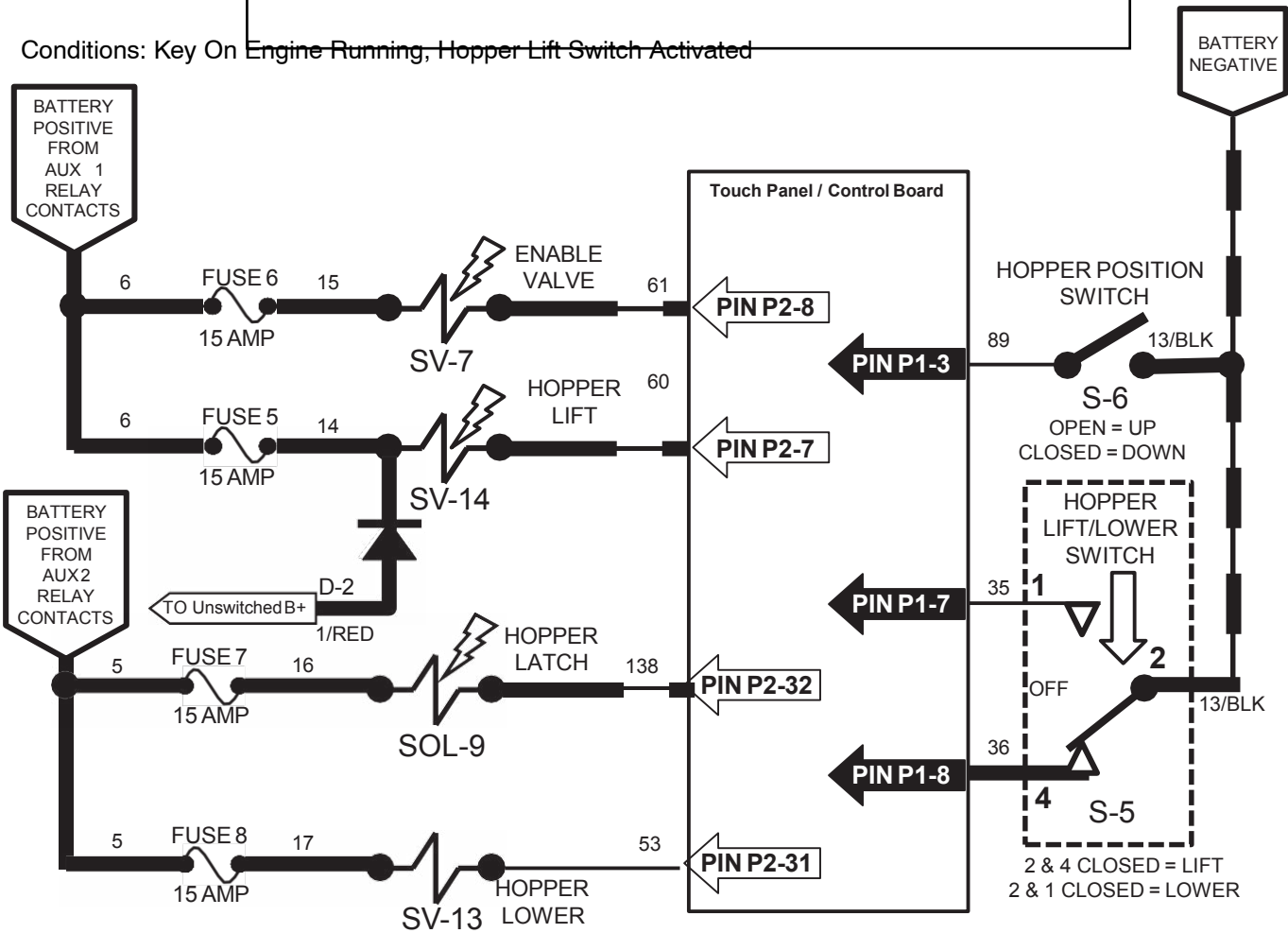

Wiring Color Codes
(Unless otherwise marked)

Right Most Digit of Wire Number	Color of Wire
0	Tan
1	Pink
2	Brown
3	Orange
4	Yellow
5	Green
6	Blue
7	Purple
8	Gray
9	White

Component	Max Amp Draw
SV-7	1.7 A
SV-13	1.7 A
SV-14	1.7 A

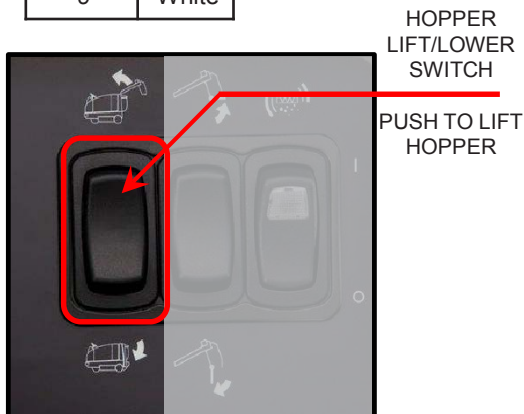

Activating the Hopper Lift/Lower Switch will cancel the sweep or scrub systems and automatically selects HIGH engine speed.



If hopper is in the full **DOWN** position when activating Hopper Lift, the **Hopper Lower Valve (SV-13)** is momentarily turned **ON** to help "jog" the hopper latch.



Hopper Latch Solenoid (**SOL-9**) is an electro-mechanical device.



Hopper Latch Solenoid (**SOL-9**) turns **ON** for 3 to 5 seconds with *each activation* of Hopper Lift Switch.

Hopper Lower

Conditions: Key On, Engine Running, Hopper/Lower Switch Activated

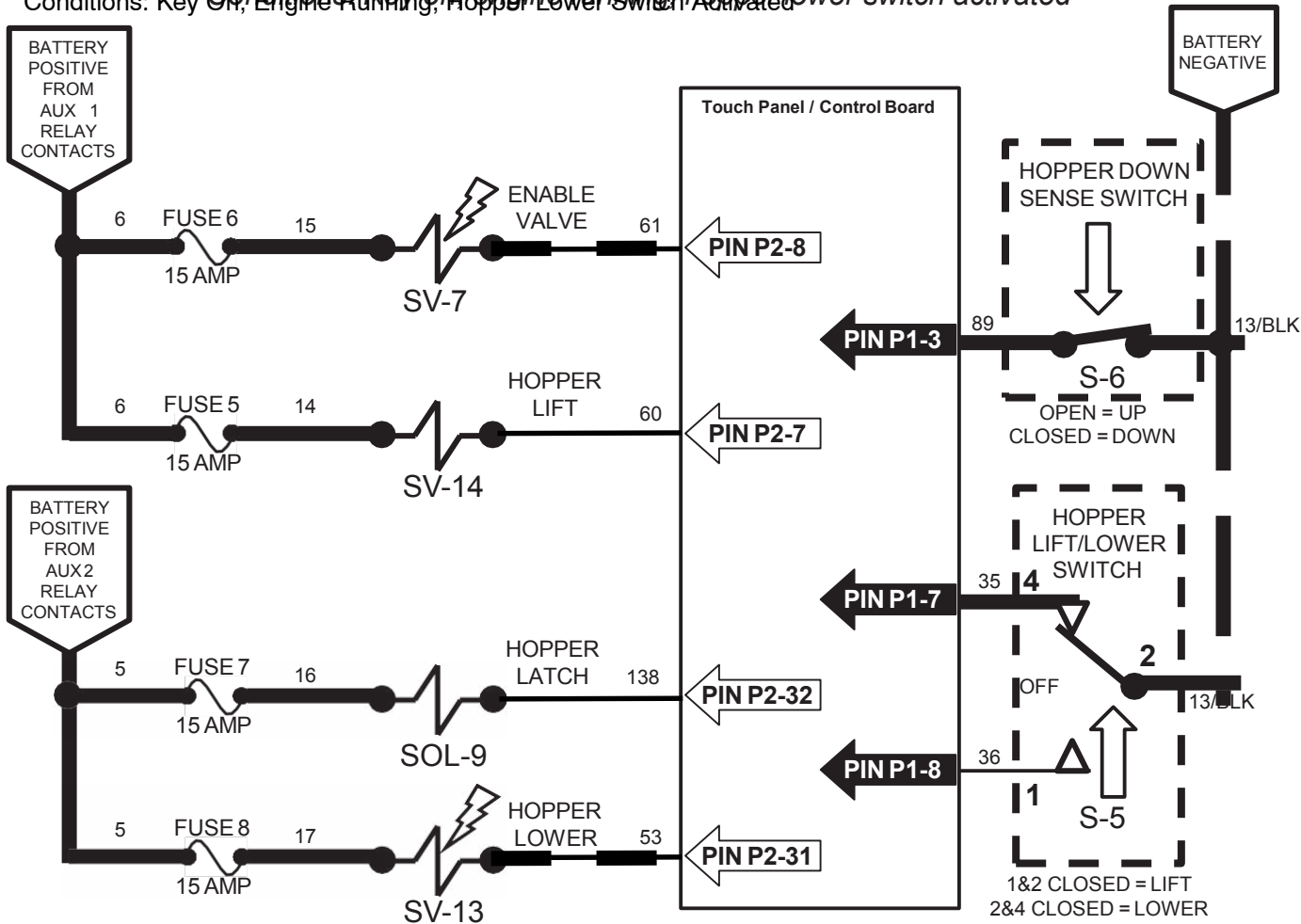

Activating the Hopper Lift/Lower Switch will cancel the sweep or scrub systems and automatically selects HIGH engine speed.



Hopper Latch solenoid (SOL-9) is an electro-mechanical device.

Wiring Color Codes
(Unless otherwise marked)

Right Most Digit of Wire Number	Color of Wire
0	Tan
1	Pink
2	Brown
3	Orange
4	Yellow
5	Green
6	Blue
7	Purple
8	Gray
9	White



HOPPER LIFT/LOWER SWITCH
PUSH TO LOWER HOPPER

Scrub Vacuum Fan On & Squeegee Down

Conditions: Key On, Engine Running, Scrubbing System & Scrub Vacuum On, Propelling

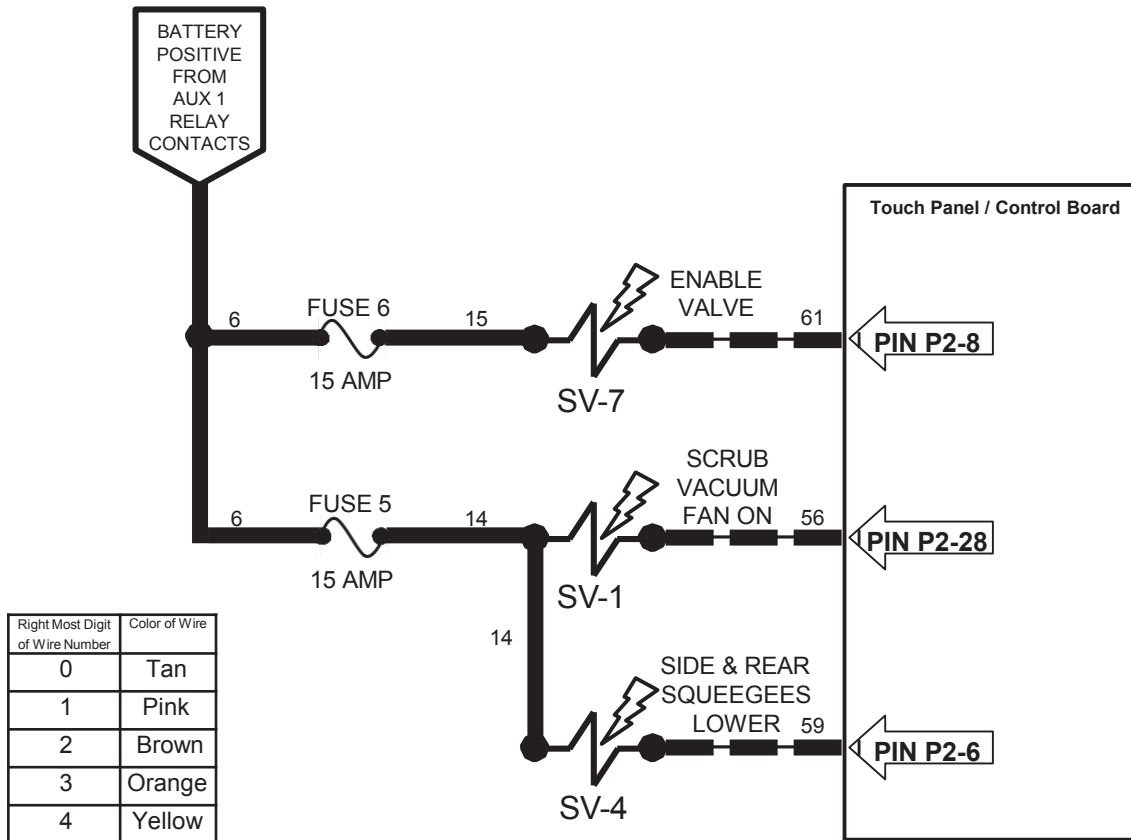

Right Most Digit of Wire Number	Color of Wire
0	Tan
1	Pink
2	Brown
3	Orange
4	Yellow
5	Green
6	Blue
7	Purple
8	Gray
9	White

Maximum Amp Draw Readings

Component	Max Amp Draw
SV-1	1.7 A
SV-4	1.7 A
SV-7	1.7 A

i Reverse propel will turn OFF SV-4 (Pin P2-6) and raise the side and rear squeegees.

i Any condition that cancels the scrub functions will also turn OFF the scrub vacuum fan and raise squeegees.

Hopper Door Open

Conditions: Key On, Engine Running, Hopper Door Open, Switch Activated

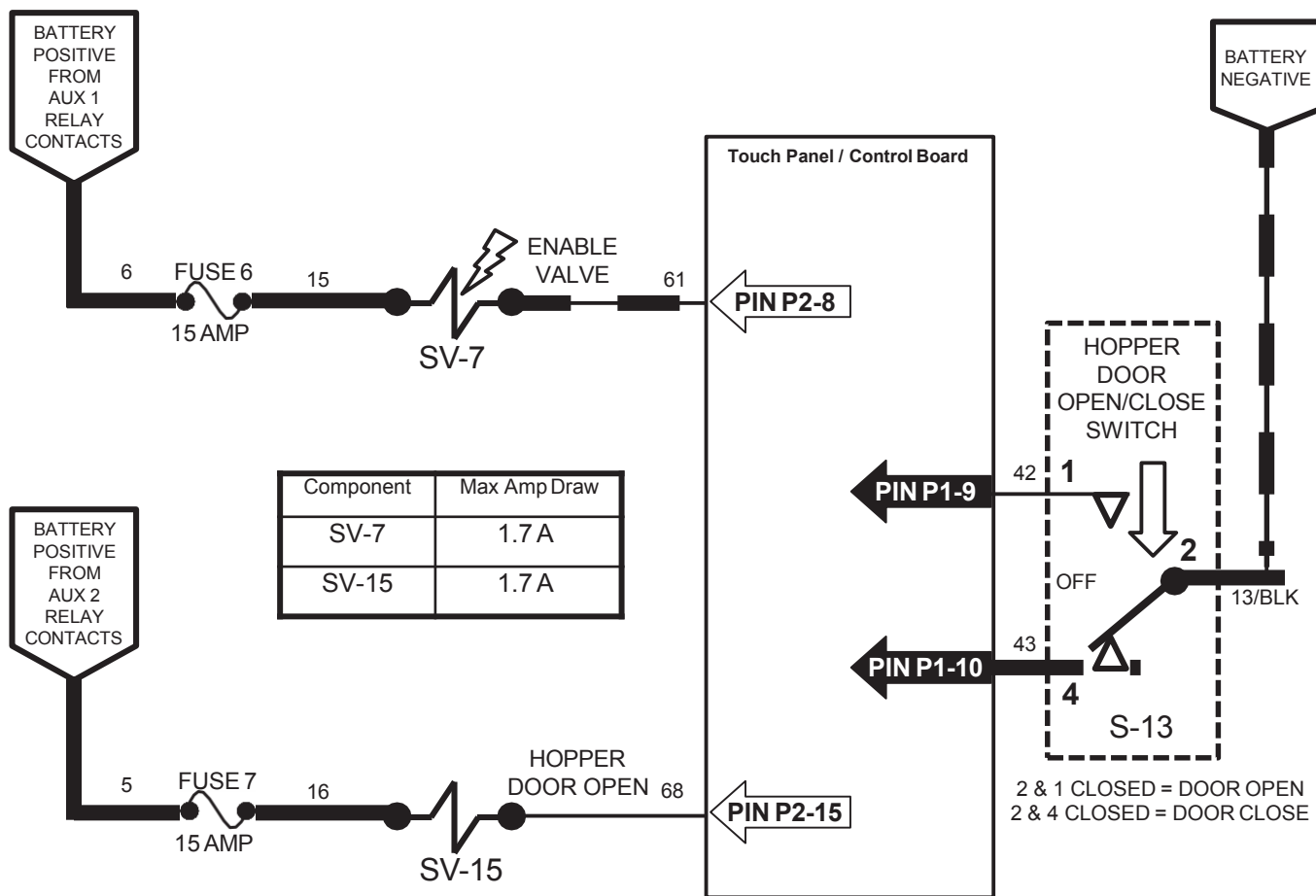

Wiring Color Codes
(Unless otherwise marked)

Right Most Digit of Wire Number	Color of Wire
0	Tan
1	Pink
2	Brown
3	Orange
4	Yellow
5	Green
6	Blue
7	Purple
8	Gray
9	White

i Anytime the Enable Valve (SV-7) is ON and the Hopper Door Open Valve (SV15) is OFF, the hopper door will close.

i Activating the Hopper Door Switch to open or close the door will cancel the sweep or scrub systems and automatically selects HIGH engine speed.

Side Brush On

Conditions: Key On, Engine Running, Scrubbing or Sweeping, Side Brush On, Propelling

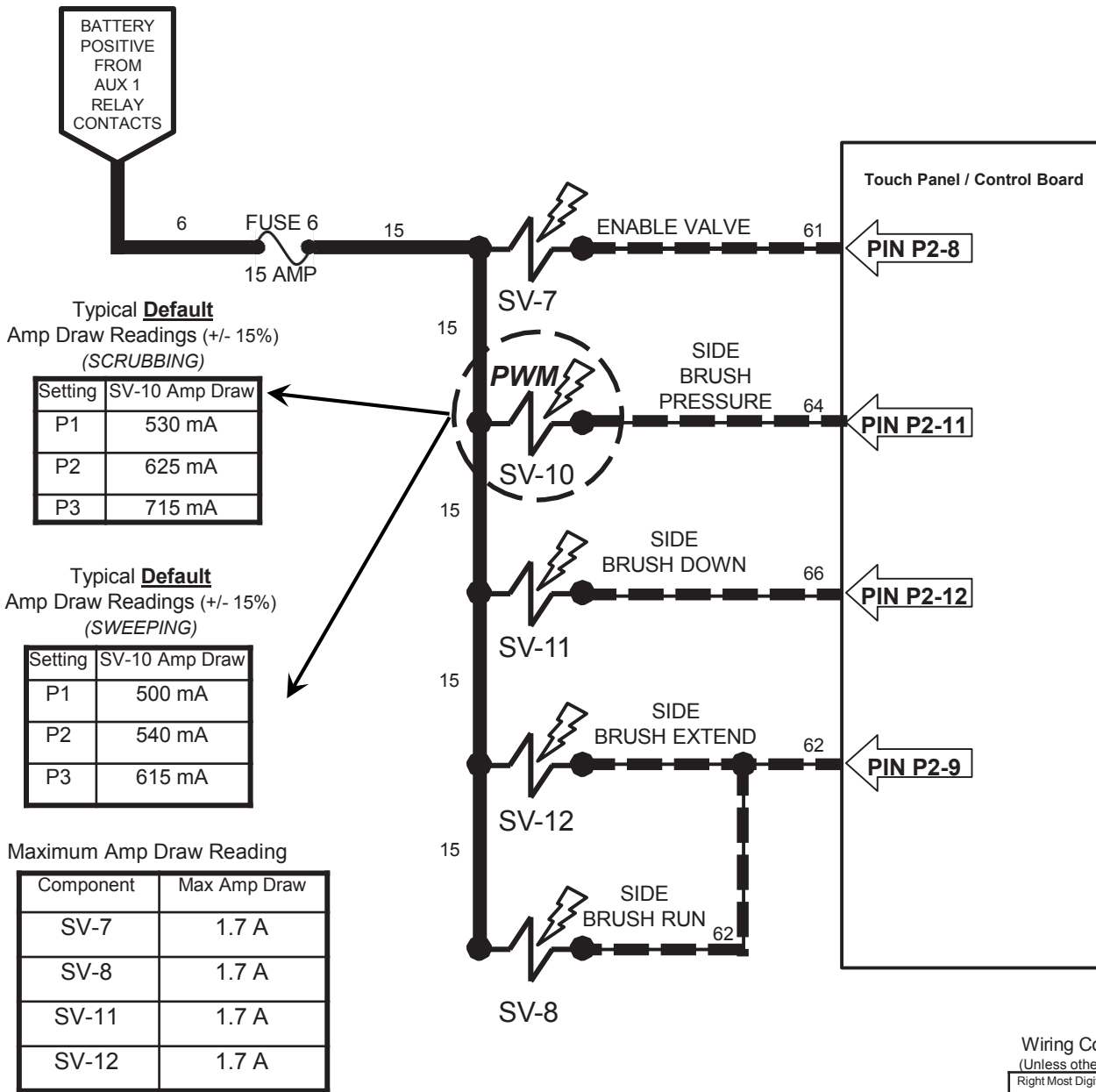

Wiring Color Codes (Unless otherwise marked)

Right Most Digit of Wire Number	Color of Wire
0	Tan
1	Pink
2	Brown
3	Orange
4	Yellow
5	Green
6	Blue
7	Purple
8	Gray
9	White



Pressure settings P1, P2, & P3 are the Touch Panel LED indicators for Brush Down Pressure.



SV-10 is controlled by PWM; a higher duty cycle (More Brush Pressure LED's lit on Touch Panel) will result in more Brush Down pressure.

Side Brush On

Conditions: Key On Engine Running, Scrubbing or Sweeping, Side-Brush On, Propelling

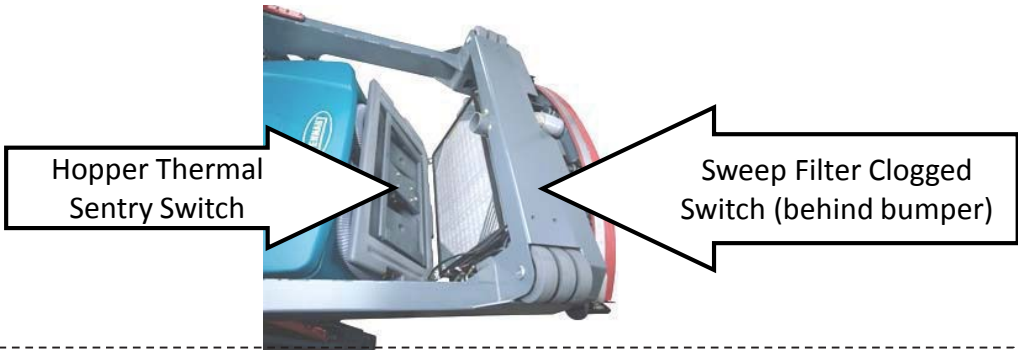
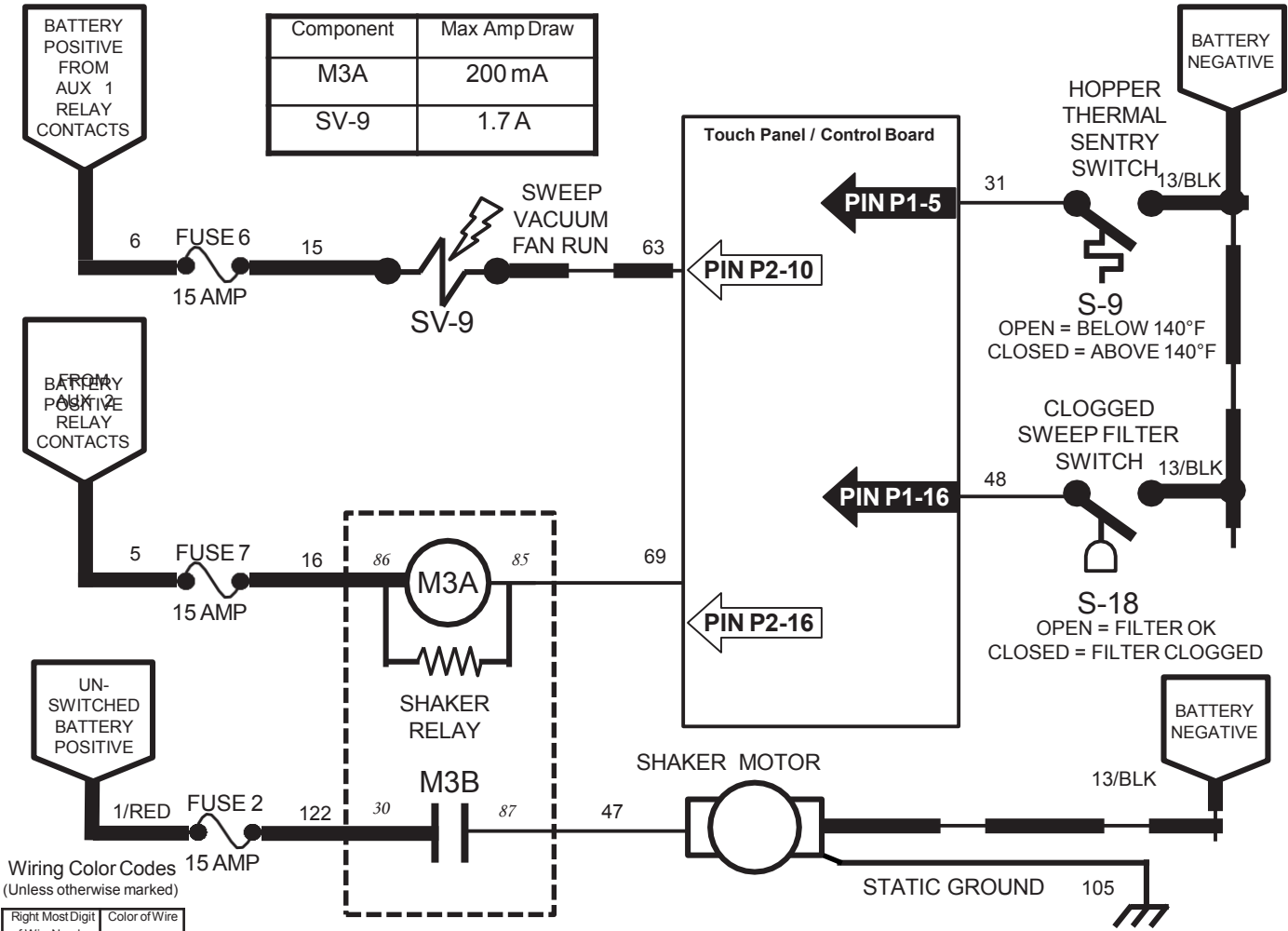

- i** A short shaker cycle is automatically performed each time the Sweep Vacuum is turned **OFF**.
- i** If the Hopper **Thermal Sentry Switch** closes (above 140°F in hopper), all sweep functions are cancelled.
- i** If **Sweep Filter Clogged Switch** closes (restriction in filter), a *fault* condition will be displayed, but vacuum fan will continue operating normally.
- i** If the shaker system is manually selected when **Sweep Vacuum Fan** is **ON**, the fan is turned **OFF** during the shaker cycle, and turned back **ON** when shaker cycle is complete.

Shaker Motor On

Conditions: Key On, ONE-STEP Sweeping Turned Off or Shaker System On

M-Series Shaker Motor On

Conditions: Key on, ONE-STEP sweeping turned off or shaker system on

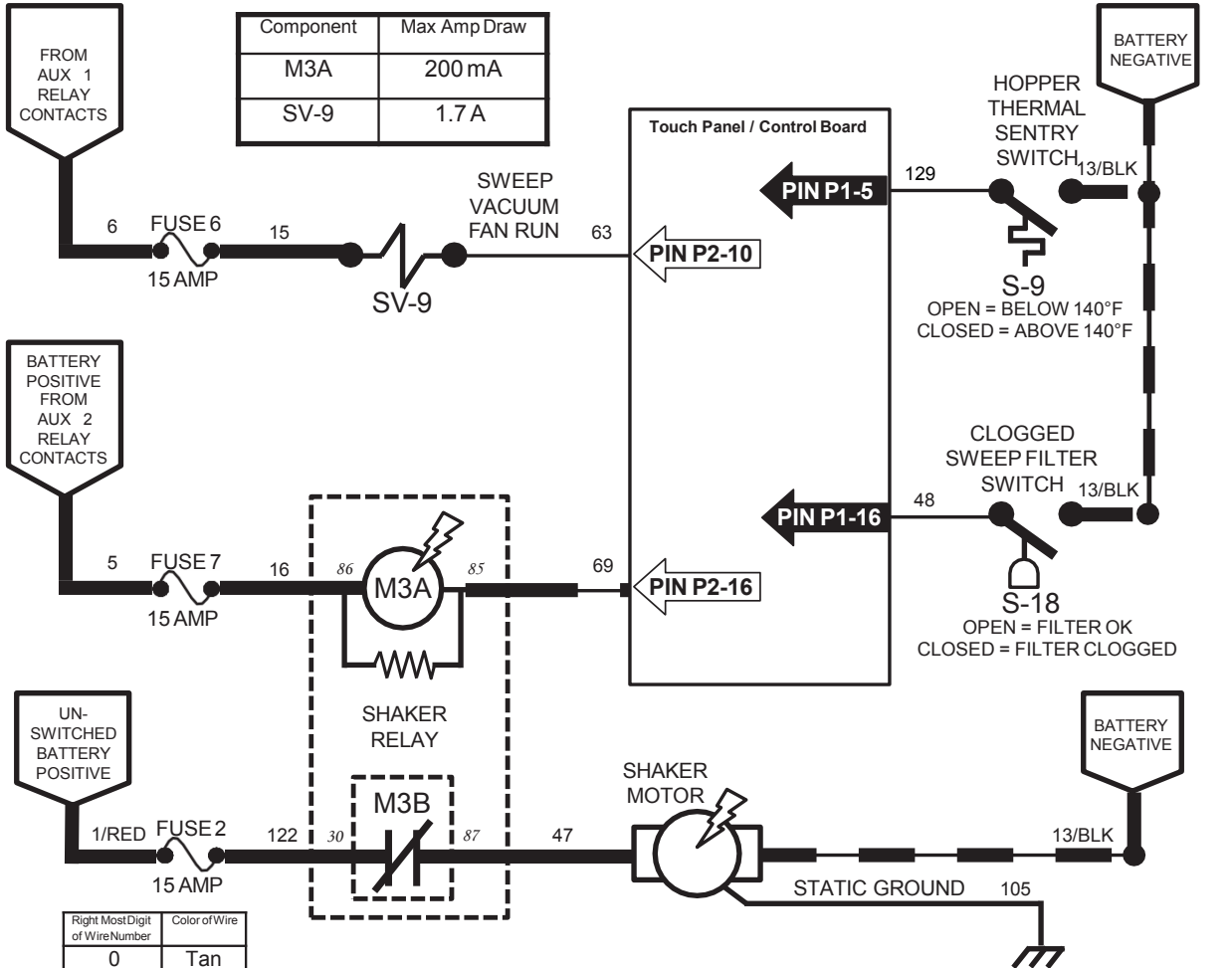

Component	Max Amp Draw
M3A	200 mA
SV-9	1.7 A

Right Most Digit of Wire Number	Color of Wire
0	Tan
1	Pink
2	Brown
3	Orange
4	Yellow
5	Green
6	Blue
7	Purple
8	Gray
9	White

Wiring Color Codes
(Unless otherwise marked)

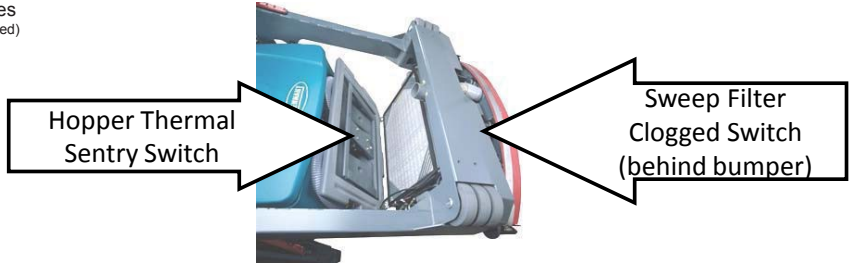

- i** A short shaker cycle is automatically performed each time the Sweep Vacuum is turned **OFF**.
- i** If the Hopper **Thermal Sentry Switch** closes (above 140°F in hopper), all sweep functions are cancelled.
- i** If **Sweep Filter Clogged Switch** closes (restriction in filter), a *fault* condition will be displayed, but vacuum fan will continue operating normally.
- i** If the shaker system is manually selected when **Sweep Vacuum Fan** is **ON**, the fan is turned **OFF** during the shaker cycle, and turned back **ON** when shaker cycle is complete.

Solution & Recovery Float Switches

Conditions: Key On

Wiring Color Codes
(Unless otherwise marked)

Right Most Digit of Wire Number	Color of Wire
0	Tan
1	Pink
2	Brown
3	Orange
4	Yellow
5	Green
6	Blue
7	Purple
8	Gray
9	White

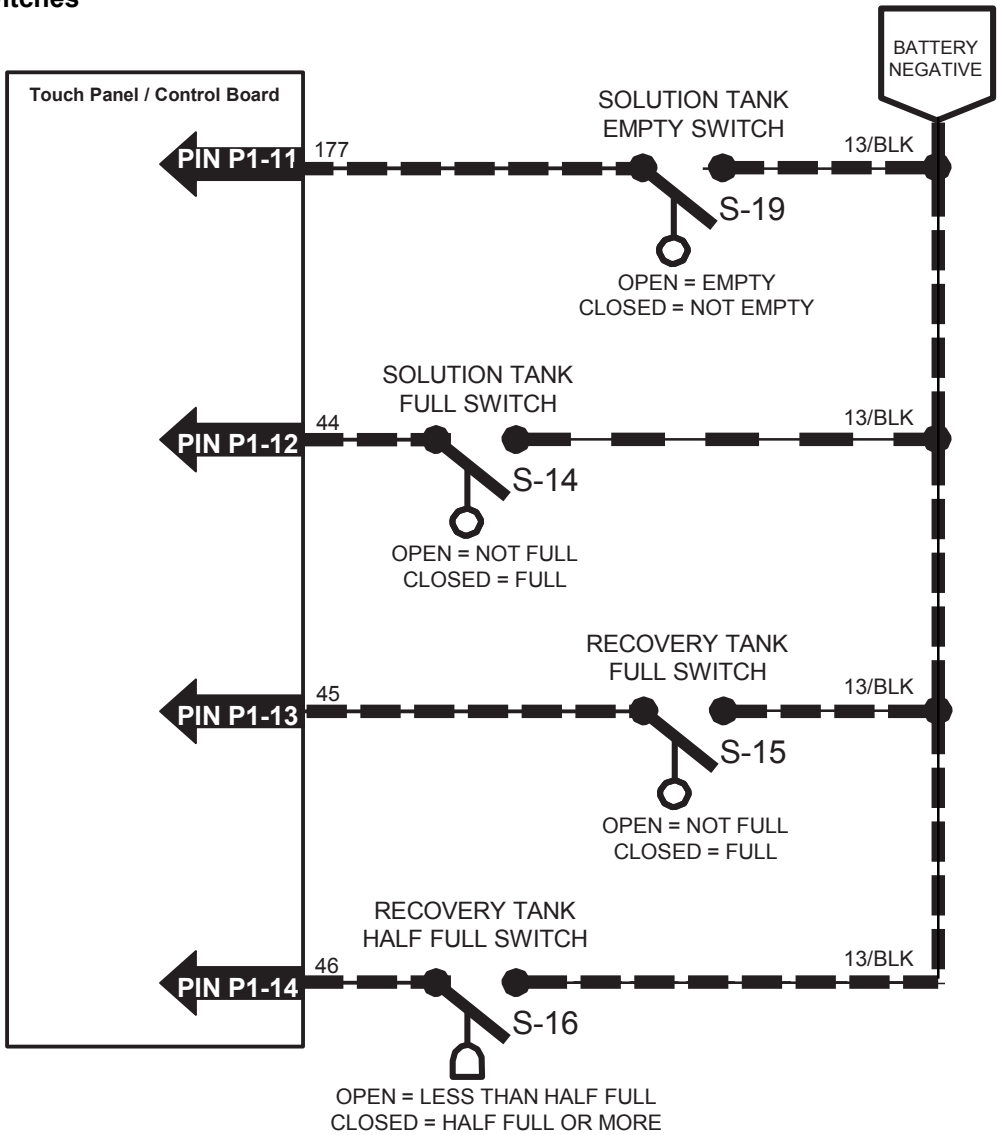

i S-14, SA-15, & S-19 are Float Switches. S-16 is a Pressure Tube Switch.

i The Tank Level Switches must be closed for five (5) seconds before any output is affected.

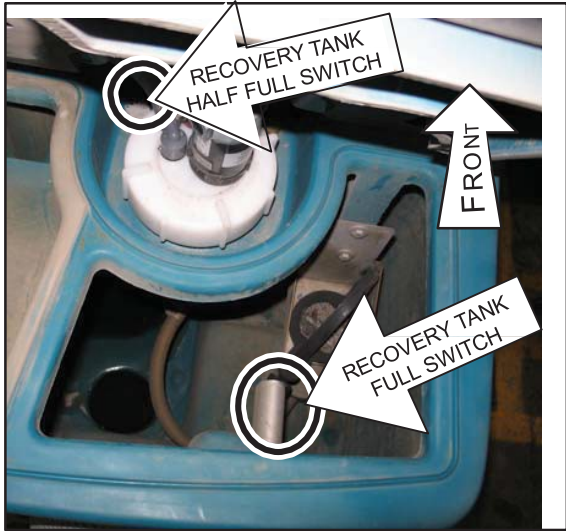
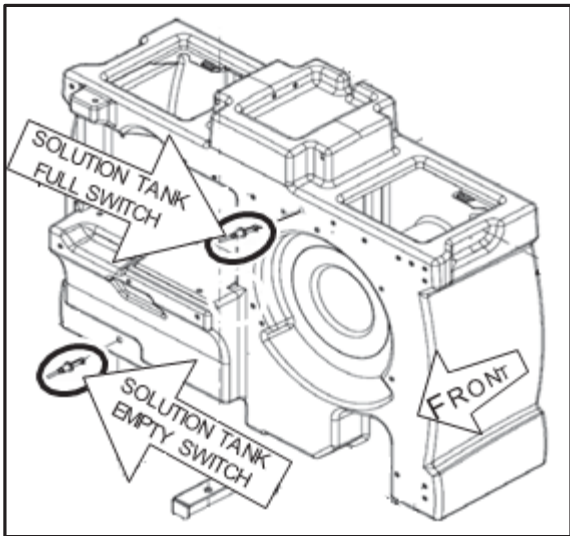

Forward Propel

Conditions: Key On

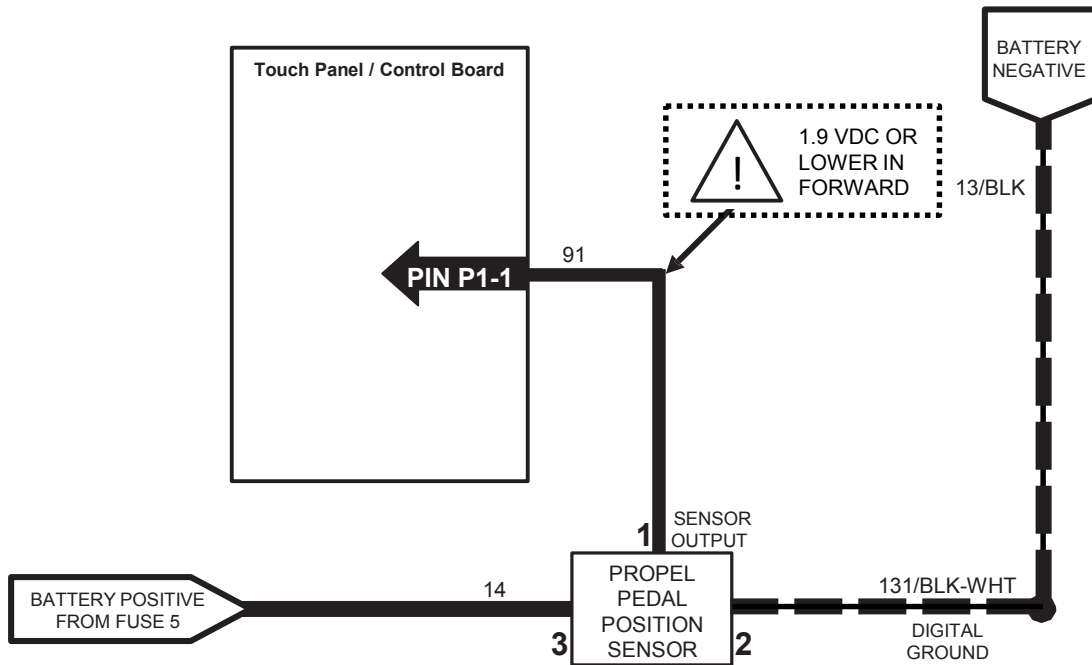

SENSOR OUTPUT VOLTAGES:
 2.0 to 2.7 VDC = NEUTRAL
 2.8 VDC OR HIGHER = REVERSE
 1.9 VDC OR LOWER = FORWARD

Propel Pedal Position Sensor Arms Adjustment

1. Enter Input Diagnostics Mode
2. Loosen sensor arms hardware
3. Tighten top bolt to snug
4. Slide arm until the light goes ON
5. Back arm out until the light goes OFF
6. Retighten all hardware

NOTE: Use the High Engine Speed LED to adjust the arm closest to the front of machine (forward adjustment), and the Low Engine Speed LED to adjust the arm closest to the rear of machine (reverse adjustment).

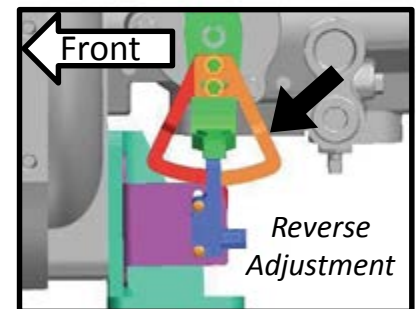
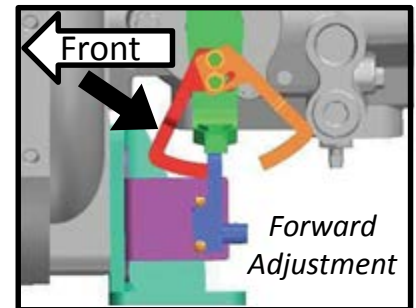

Wiring Color Codes
(Unless otherwise marked)

Right Most Digit of Wire Number	Color of Wire
0	Tan
1	Pink
2	Brown
3	Orange
4	Yellow
5	Green
6	Blue
7	Purple
8	Gray
9	White

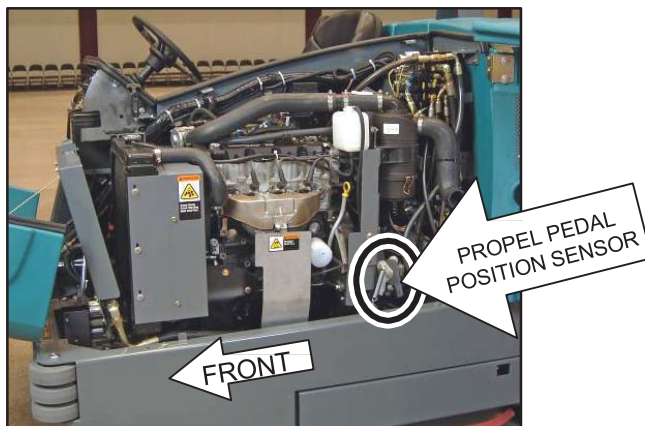

Auto Fill Solenoids

Conditions: Key On

Component	Max Amp Draw
SOL-1	1.7 A
SOL-2	1.7 A

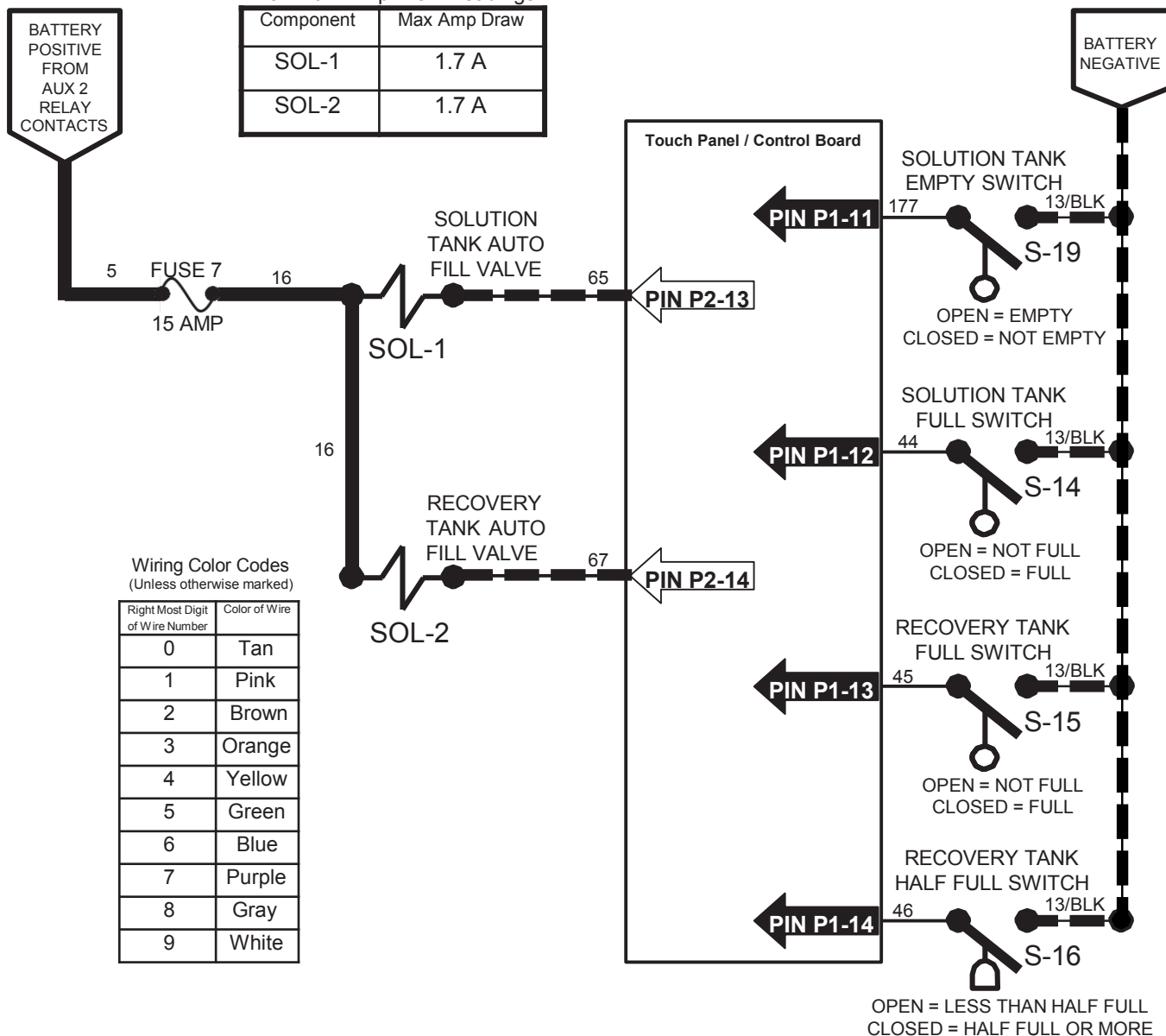

- i** S-14, S-15, & S-19 are Float Switches. S-16 is a Pressure Tube Switch.
- i** Solution and Recovery Tank Auto Fill solenoids (SOL-1 & 2) are electro-mechanical devices.
- i** Machine must be in neutral and Solution Tank Full Switch OPEN (tank not full) to activate Solution Tank Auto Fill Valve (SOL-1)..
- i** Machine must be in neutral and Recovery Tank Half Full Switch OPEN (tank less than half full) to activate Recovery Tank Auto Fill Valve (SOL-2).
- i** The Tank Level Switch must be closed for five (5) seconds before any output is affected..

Conventional Detergent Pump & ES Pump

Conditions: Key On, Engine Running, Scrubbing system On, ES System On, Two or Three Solution LED's Lit

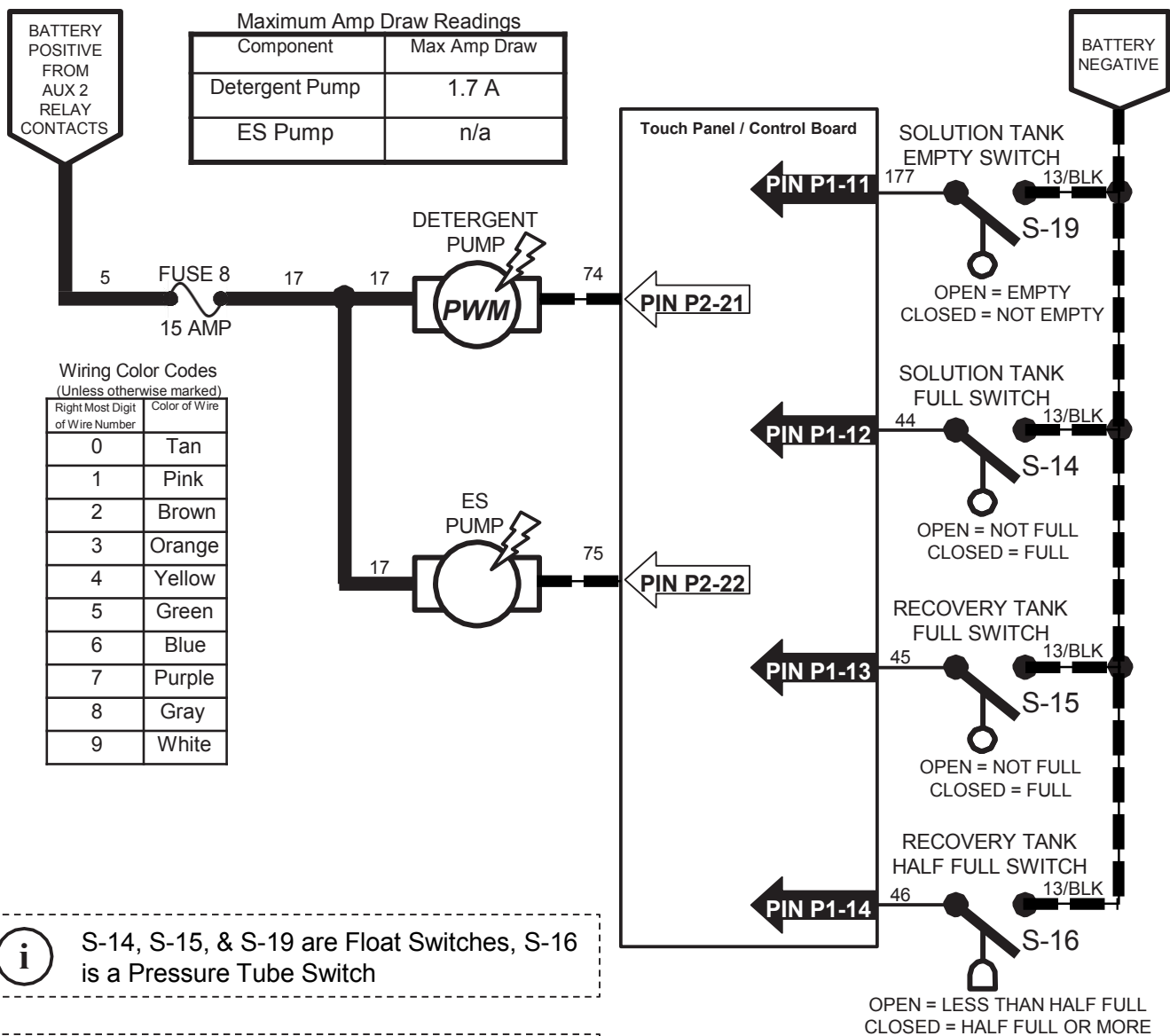

i S-14, S-15, & S-19 are Float Switches, S-16 is a Pressure Tube Switch

i The Tank Level Switches must be closed for 5 seconds before any output is affected.

i The Detergent Pump is controlled by PWM; A higher duty cycle (more Solution LED's lit on Touch Panel) will result in more detergent & solution applied to floor

i The Recovery Tank must be at least half full for ES Pump to turn ON. This will begin a 30 second run cycle of the ES Pump. If the Recovery Tank is still at least half full after the cycle, another 30 second cycle will begin. If a full Solution Tank is sensed, the ES Pump will turn OFF before completing 30 second cycle.

Horn

Conditions: Key On, Switch Activated

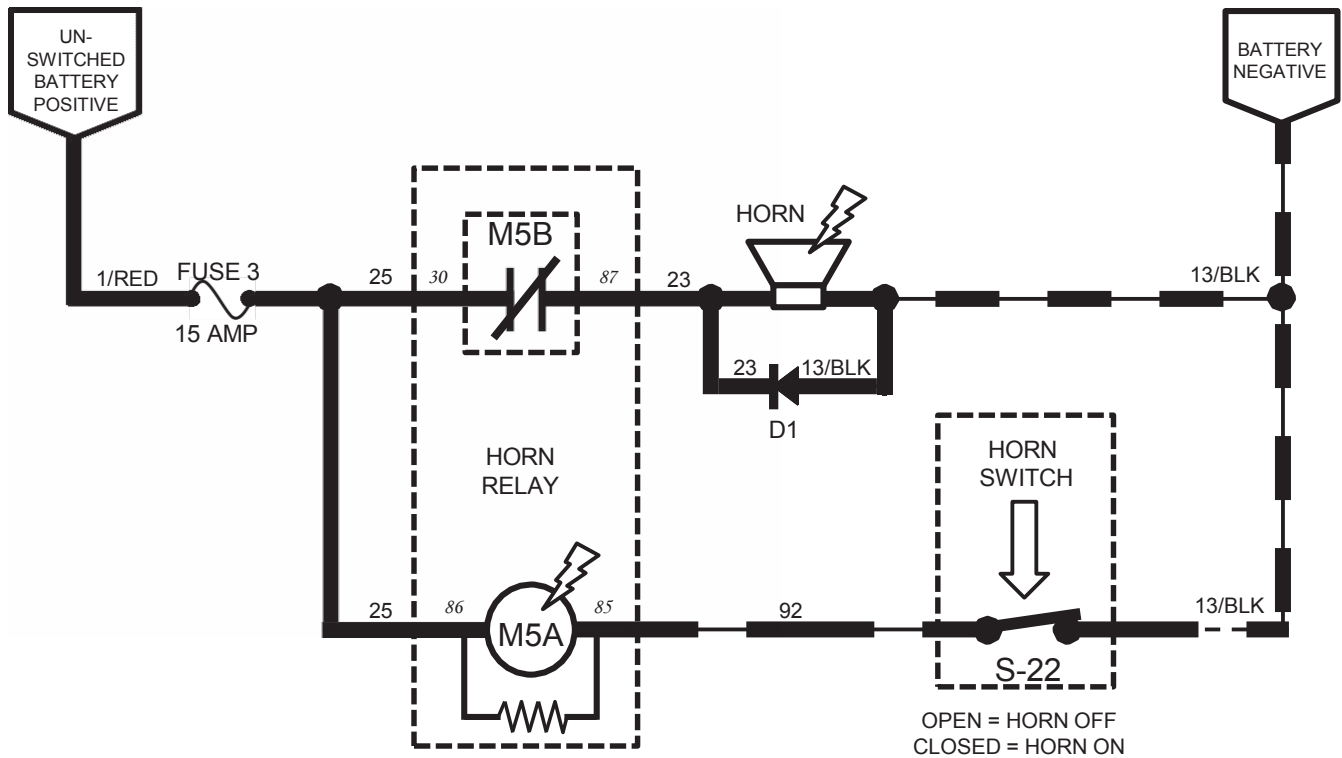

Wiring Color Codes
(Unless otherwise marked)

Right Most Digit of Wire Number	Color of Wire
0	Tan
1	Pink
2	Brown
3	Orange
4	Yellow
5	Green
6	Blue
7	Purple
8	Gray
9	White



Horn Location
Membrane Panel

Horn Location
Pro Panel



Hopper Door Closed

Conditions: Key On, Engine Running, Hopper Door Close Switch Activated

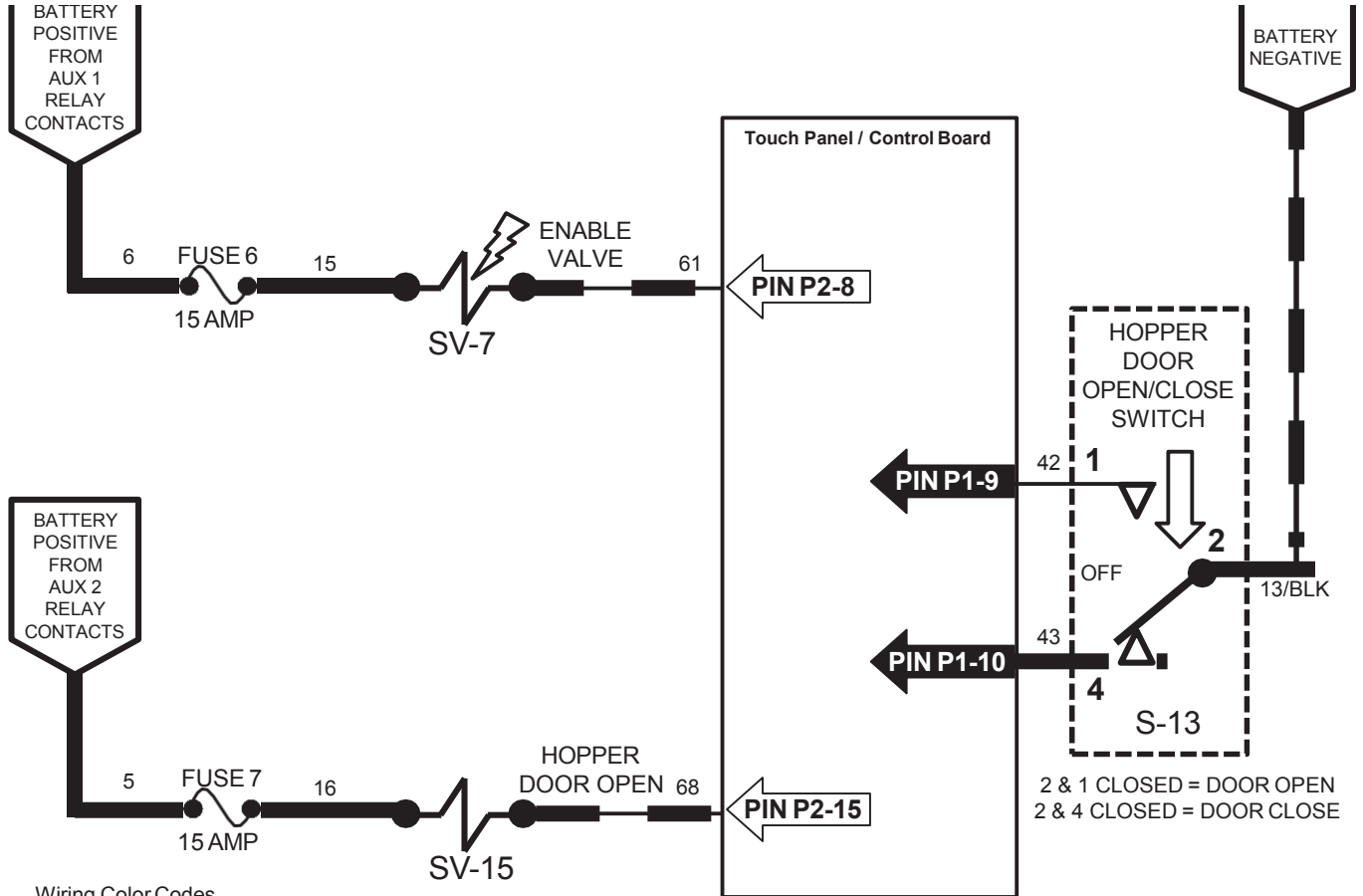

Wiring Color Codes
(Unless otherwise marked)

Right Most Digit of Wire Number	Color of Wire
0	Tan
1	Pink
2	Brown
3	Orange
4	Yellow
5	Green
6	Blue
7	Purple
8	Gray
9	White

Component	Max Amp Draw
SV-7	1.7 A
SV-15	1.7 A

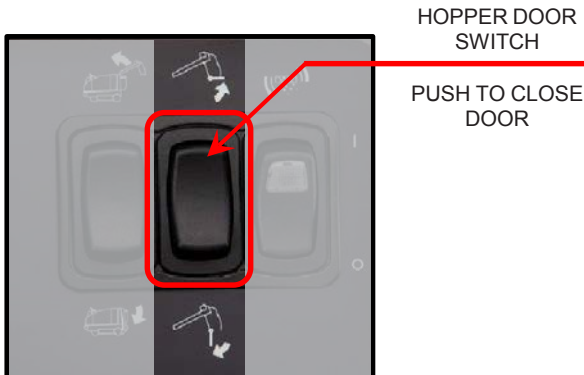

i Anytime the Enable Valve (SV-7) is ON and the Hopper Door Open Valve (SV15) is OFF, the hopper door will close.

i Activating the Hopper Door Switch to open or close the door will cancel the sweep or scrub systems and automatically selects HIGH engine speed.

Reverse Propel

Conditions: Key On Engine Running, Propel Pedal Pushed for Reverse

M-Series Reverse Propel

Conditions: Key on, engine running, propel pedal pushed for reverse

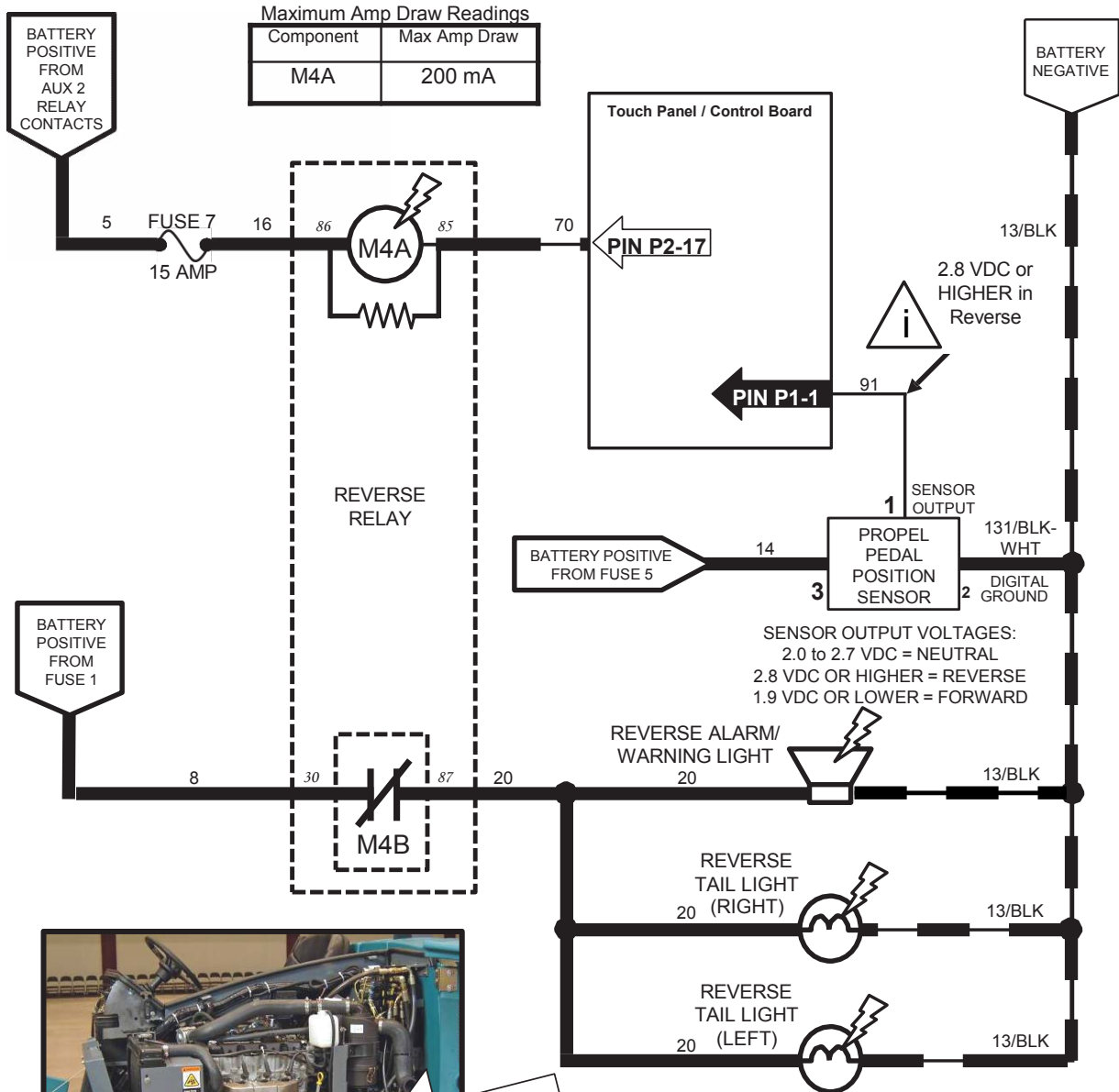

SENSOR OUTPUT VOLTAGES:
 2.0 to 2.7 VDC = NEUTRAL
 2.8 VDC OR HIGHER = REVERSE
 1.9 VDC OR LOWER = FORWARD

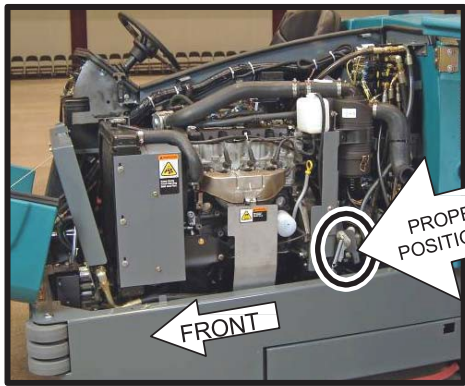

Wiring Color Codes (Unless otherwise marked)

Right Most Digit of Wire Number	Color of Wire
0	Tan
1	Pink
2	Brown
3	Orange
4	Yellow
5	Green
6	Blue
7	Purple
8	Gray
9	White

- i** See Forward Propel page for information on adjusting Propel Pedal Position Sensor.
- i** Reverse propel will turn OFF SV-4 (Pin P2-6) and raise the side and rear squeegees.

Shutdown Relay (Normal Machine Operation)

- (Gas / LP) -

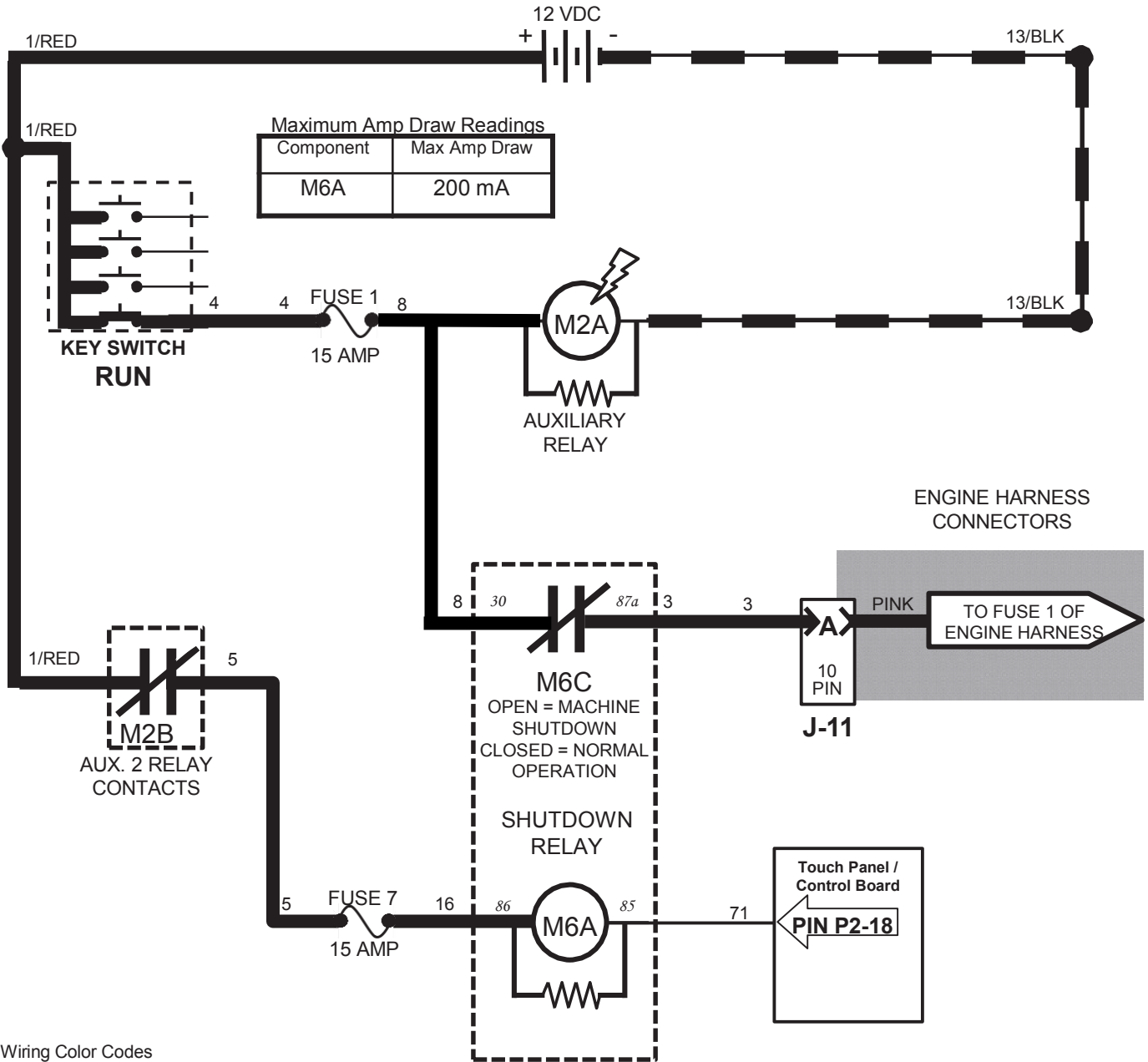

Wiring Color Codes
(Unless otherwise marked)

Right Most Digit of Wire Number	Color of Wire
0	Tan
1	Pink
2	Brown
3	Orange
4	Yellow
5	Green
6	Blue
7	Purple
8	Gray
9	White

i The Shutdown system is used to turn OFF the engine under certain conditions on machines with certain optional equipment.

i When control board turns ON M6A, the engine ECM loses power, and the engine shuts OFF.

Shutdown Relay (Normal Machine Operation)

- (Diesel) -

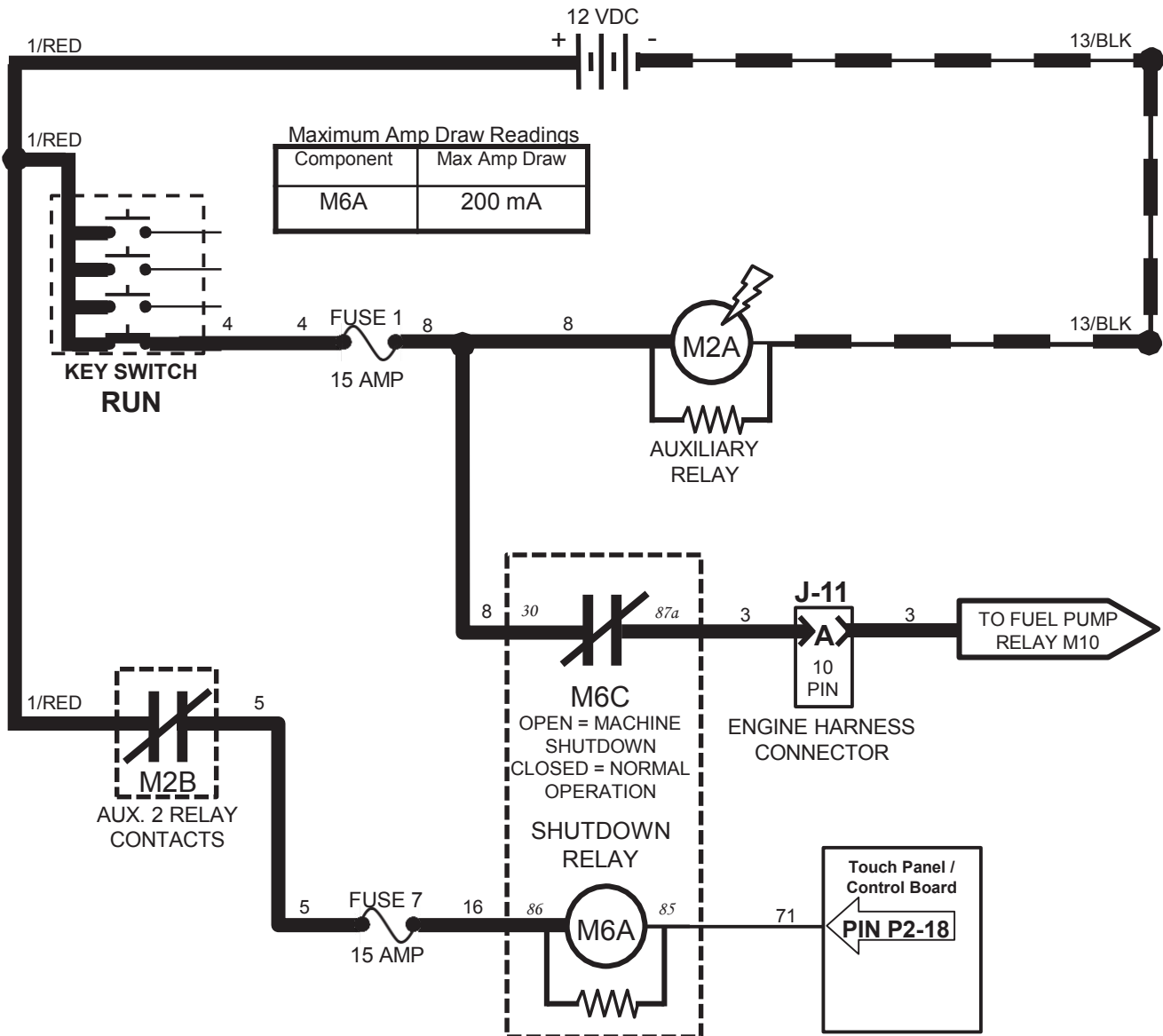

Maximum Amp Draw Readings

Component	Max Amp Draw
M6A	200 mA

Wiring Color Codes
(Unless otherwise marked)

Right Most Digit of Wire Number	Color of Wire
0	Tan
1	Pink
2	Brown
3	Orange
4	Yellow
5	Green
6	Blue
7	Purple
8	Gray
9	White

i The Shutdown system is used to turn OFF the engine under certain conditions on machines with certain optional equipment.

i When control board turns ON M6A, the engine ECM loses power, and the engine shuts OFF.

Shutdown Relay (Shutdown Mode)

- (Gas / LP) -

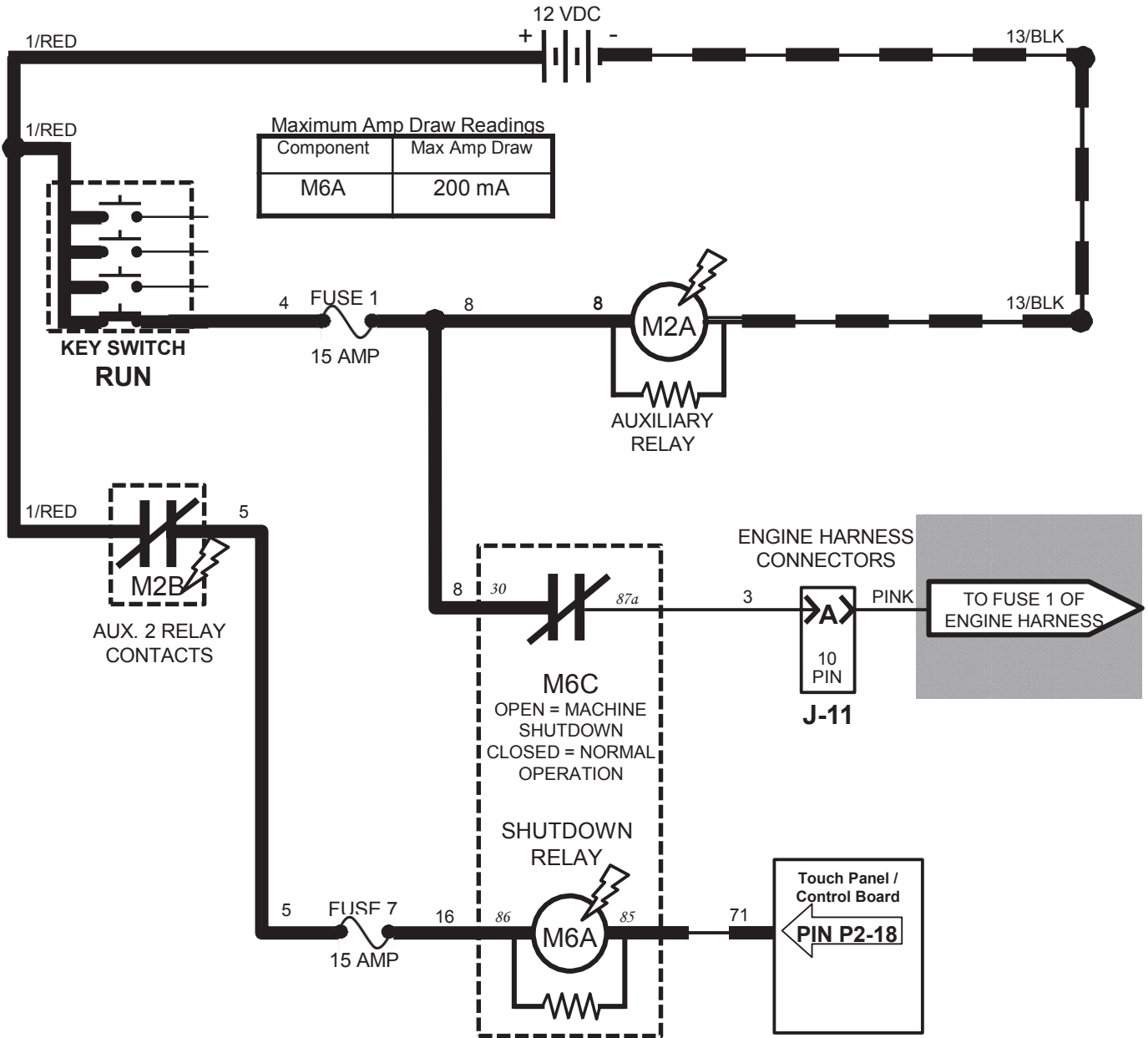

Maximum Amp Draw Readings

Component	Max Amp Draw
M6A	200 mA

Wiring Color Codes
(Unless otherwise marked)

Right Most Digit of Wire Number	Color of Wire
0	Tan
1	Pink
2	Brown
3	Orange
4	Yellow
5	Green
6	Blue
7	Purple
8	Gray
9	White

i The Shutdown system is used to turn OFF the engine under certain conditions on machines with certain optional equipment.

i When control board turns ON M6A, the engine ECM loses power, and the engine shuts OFF.

Shutdown Relay (Shutdown Mode)

- (Diesel) -

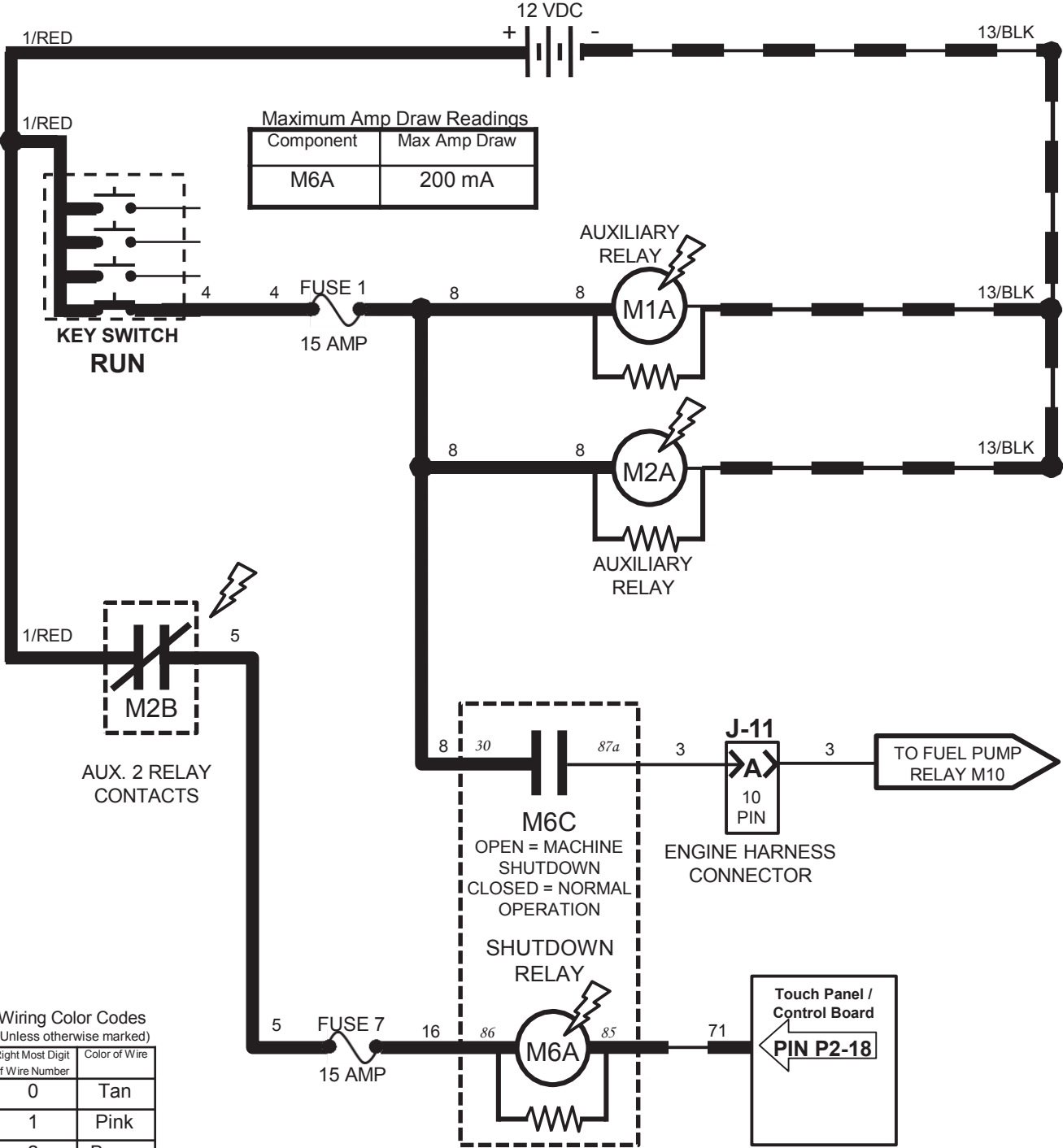

Wiring Color Codes (Unless otherwise marked)

Right Most Digit of Wire Number	Color of Wire
0	Tan
1	Pink
2	Brown
3	Orange
4	Yellow
5	Green
6	Blue
7	Purple
8	Gray
9	White

i The Shutdown system is used to turn OFF the engine under certain conditions on machines with certain optional equipment.

i When control board turns ON M6A, the engine ECM loses power, and the engine shuts OFF.

Starting System On

Condition: Key Turned To Start Position - (Gas / LP) -

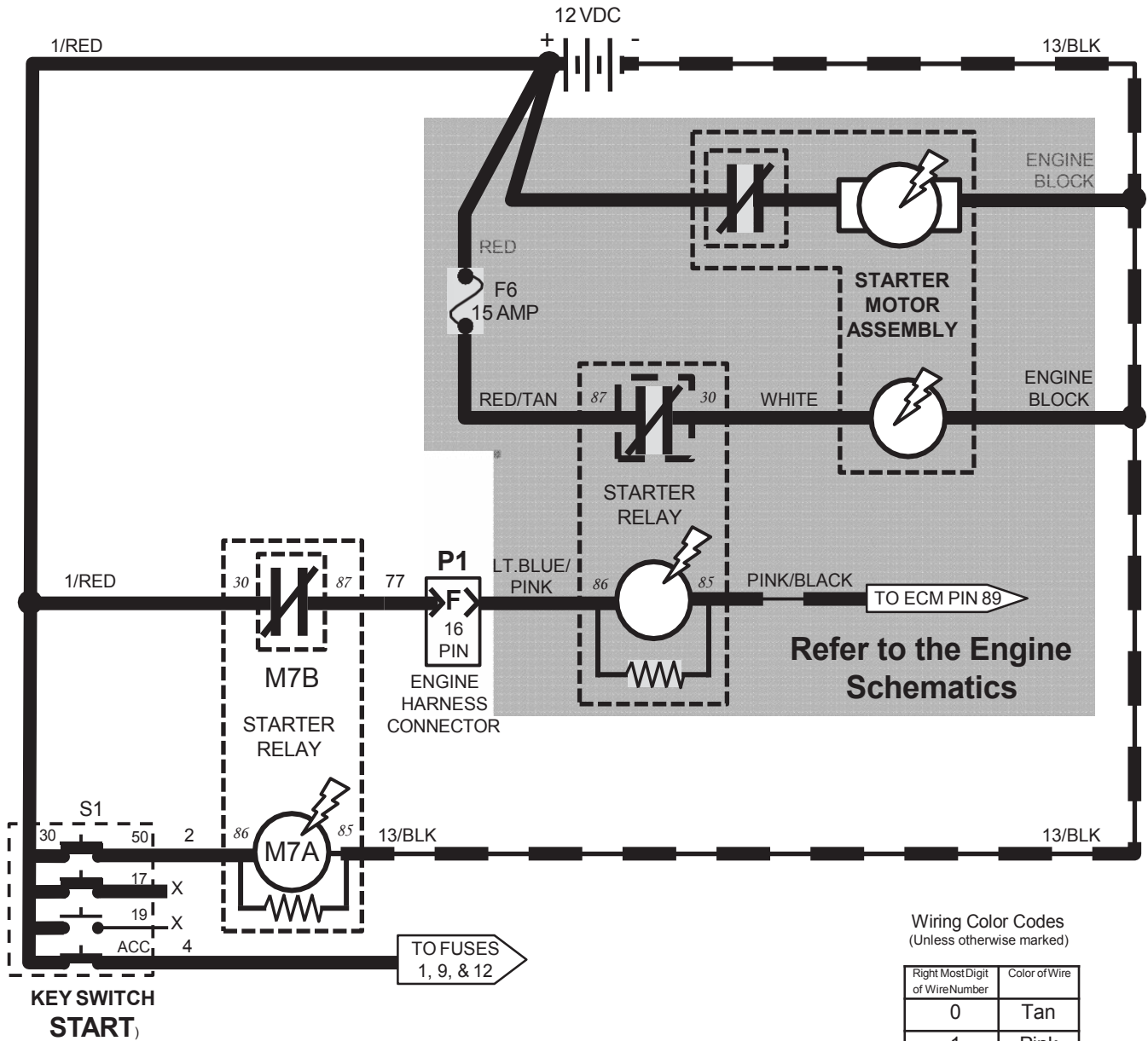

Wiring Color Codes
(Unless otherwise marked)

Right Most Digit of Wire Number	Color of Wire
0	Tan
1	Pink
2	Brown
3	Orange
4	Yellow
5	Green
6	Blue
7	Purple
8	Gray
9	White

Starting System On

Condition: Key Turned To Start Position - (Diesel) -

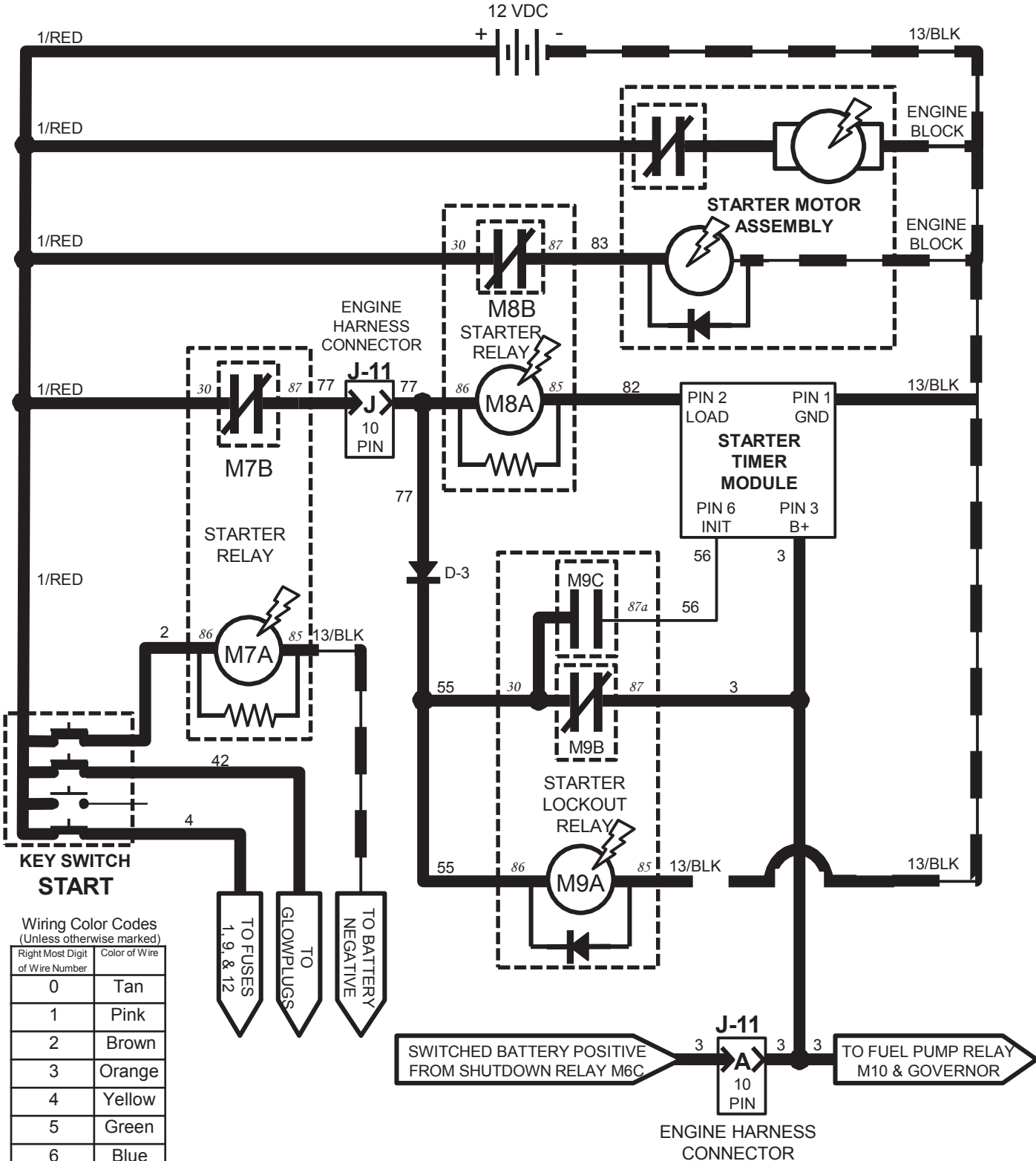

Wiring Color Codes
(Unless otherwise marked)

Right Most Digit of Wire Number	Color of Wire
0	Tan
1	Pink
2	Brown
3	Orange
4	Yellow
5	Green
6	Blue
7	Purple
8	Gray
9	White

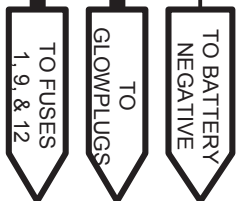

i The Starter Timer creates a delay between start attempts.

Glow Plugs On

Condition: Key Turned To Glow Plug / Start Position - (Diesel) -

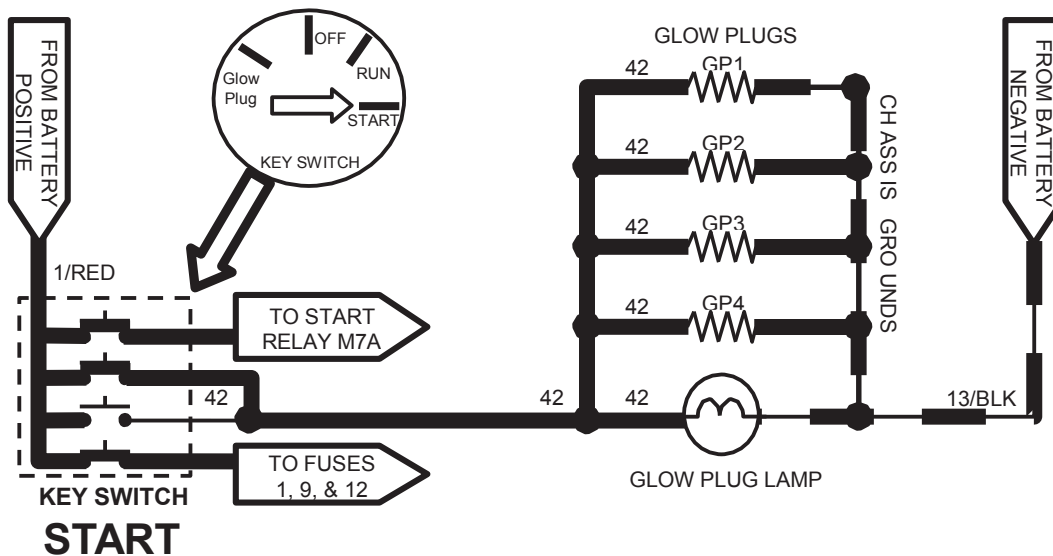
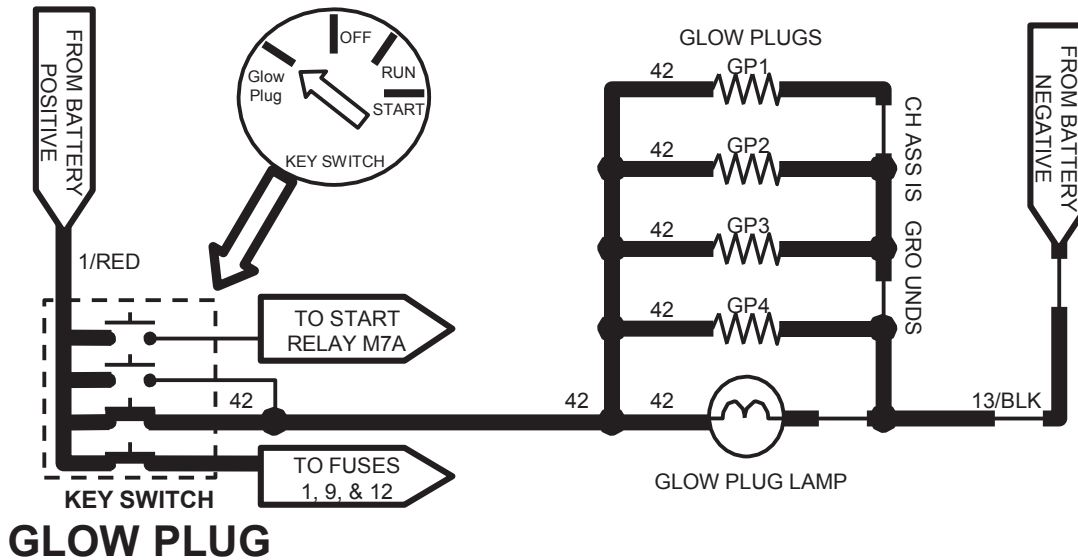

Wiring Color Codes
(Unless otherwise marked)

Right Most Digit of Wire Number	Color of Wire
0	Tan
1	Pink
2	Brown
3	Orange
4	Yellow
5	Green
6	Blue
7	Purple
8	Gray
9	White

i The Glow Plugs are ON **ONLY** when ignition switch is in the "Glow Plug" or "Start" Position.

Conventional Main & Side Brush Solution Valves

Condition: Key On, Scrubbing System On, Side Brush On, Propelling, One or more Solution LED's Lit

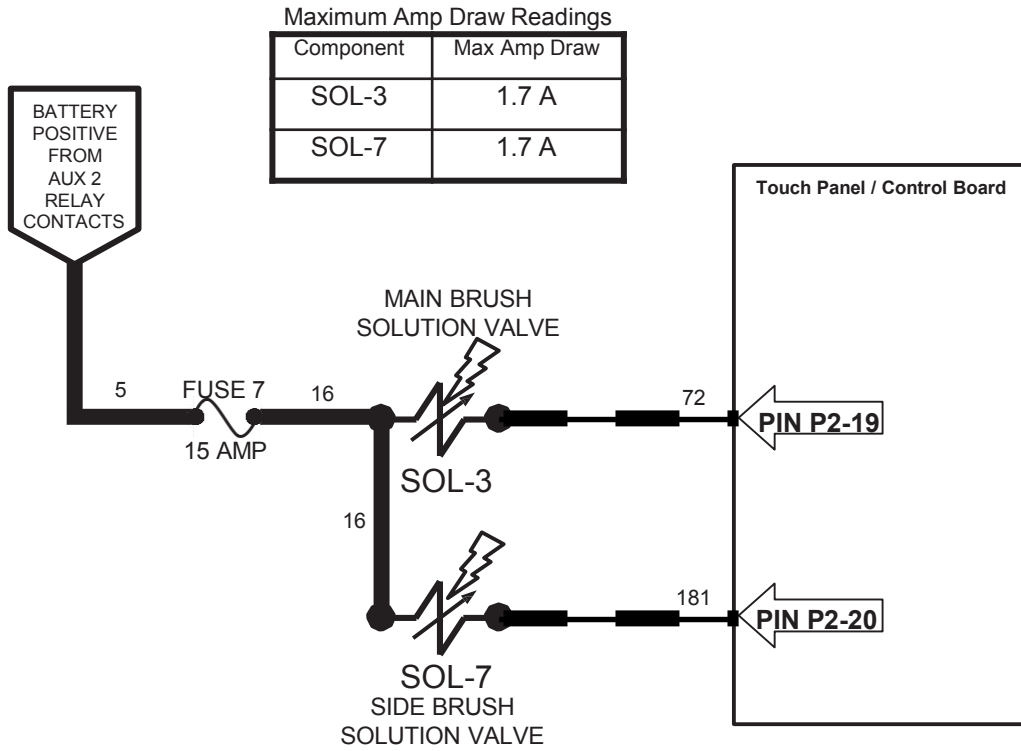

Wiring Color Codes (Unless otherwise marked)

Right Most Digit of Wire Number	Color of Wire
0	Tan
1	Pink
2	Brown
3	Orange
4	Yellow
5	Green
6	Blue
7	Purple
8	Gray
9	White

i The Solution Valves are pulsed slowly to adjust the solution volume. Less OFF time (more Solution LED's lit on Touch Panel) will result in more solution applied to floor.

i The Solution Valves will function only while propelling forward or reverse during scrub operation.

FaST System On

Condition: Key On, Scrubbing System On, Side Brush On, Propelling, One or More Solution LED's On

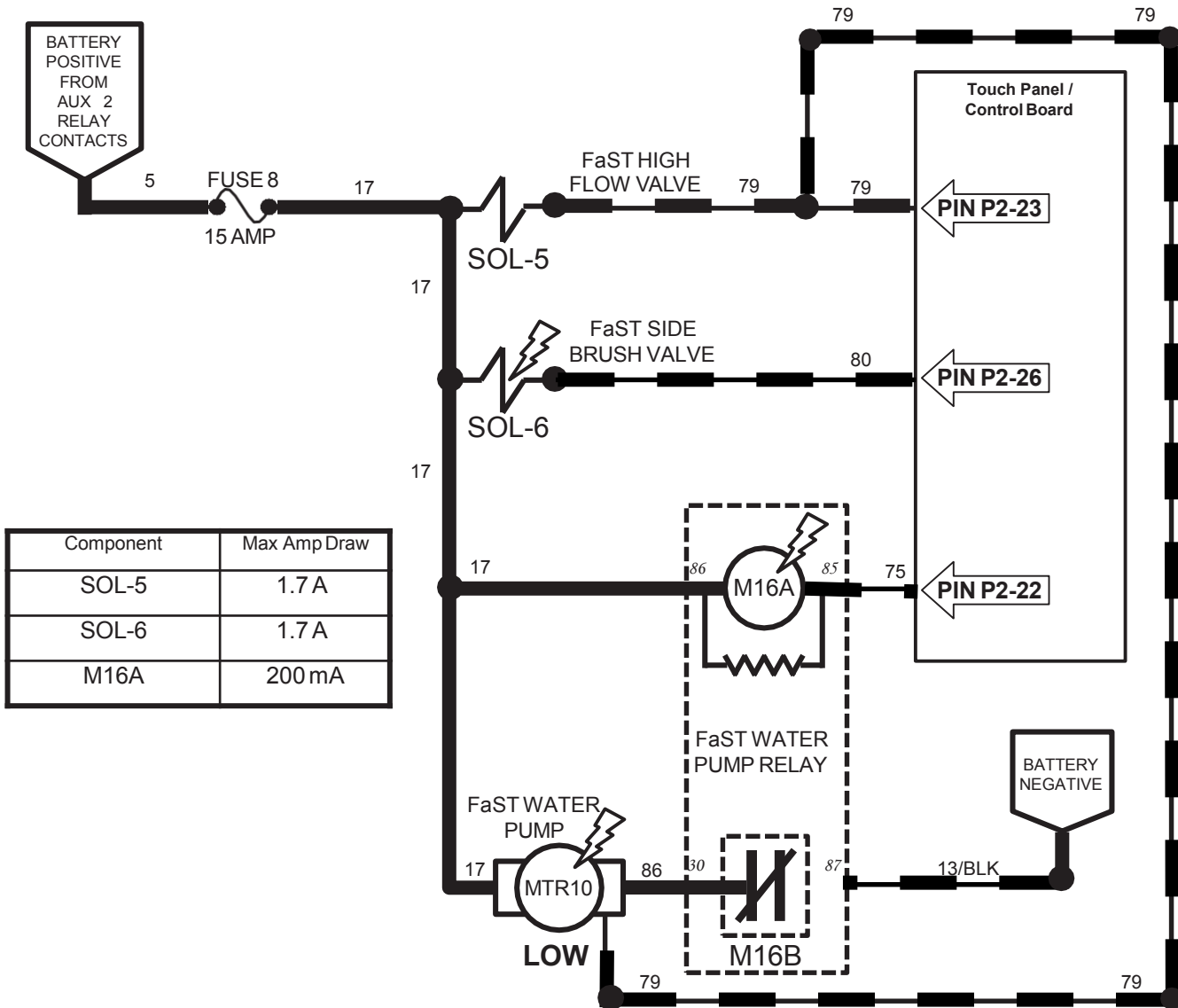

Wiring Color Codes (Unless otherwise marked)

Right Most Digit of Wire Number	Color of Wire
0	Tan
1	Pink
2	Brown
3	Orange
4	Yellow
5	Green
6	Blue
7	Purple
8	Gray
9	White



The FaST Water Pump has two speeds (Low Flow & High Flow). When there is no input to the pump on Wire 79/White (open), Low Flow is selected. When Battery Negative is input to the pump on Wire 79/White, High Flow is selected.



One or two Solution LED's lit selects Low FaST output.



FaST High Flow Valve is ON only when all 3 Solution LED's are lit.

Fuel Level Sensor (Gas / LP / Diesel)

Condition: Key On

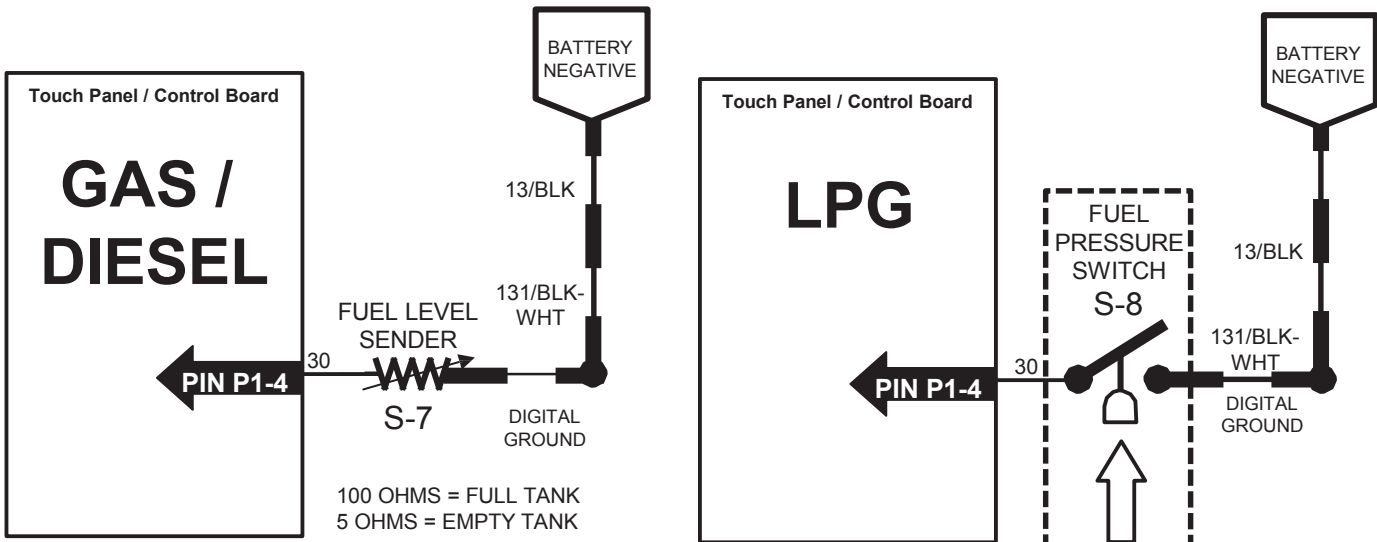

NORMALLY CLOSED, HELD OPEN BY FUEL PRESSURE

OPEN = MORE THAN 70 PSI
CLOSED = 70 PSI OR LOWER

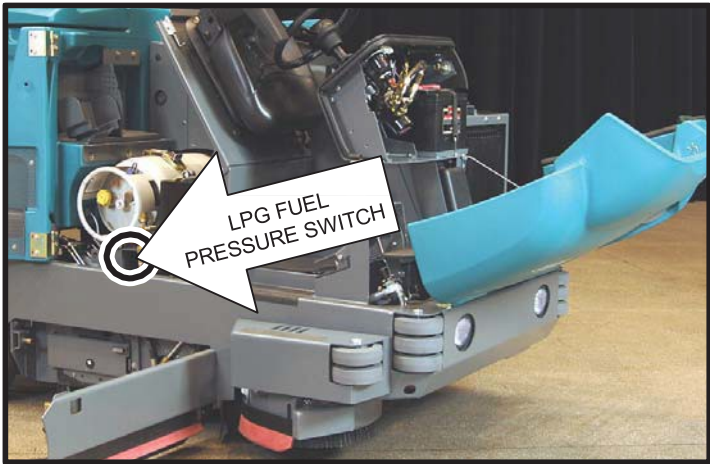
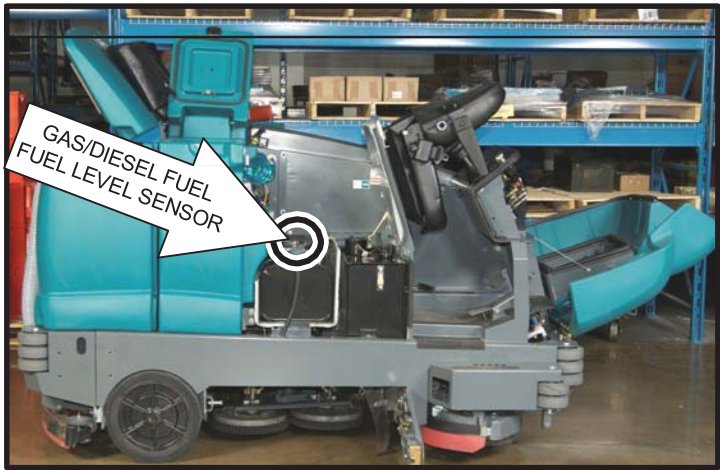

Wiring Color Codes
(Unless otherwise marked)

Right Most Digit of Wire Number	Color of Wire
0	Tan
1	Pink
2	Brown
3	Orange
4	Yellow
5	Green
6	Blue
7	Purple
8	Gray
9	White

Impact, Hydraulic Temperature & Filter Sensors

Condition: Key On

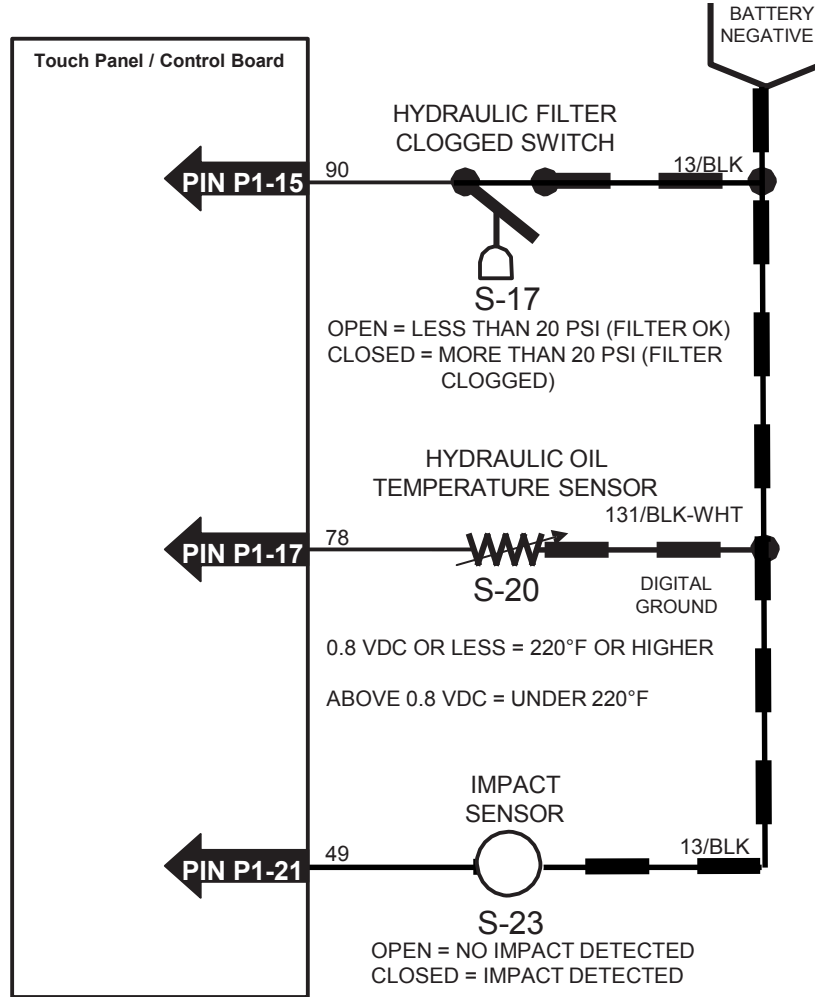

The Hydraulic Filter Clogged Switch will not be sensed until after the machine has run for 5 minutes to allow the hydraulic oil to warm up.



Impact Sensor S-23 is used only on machines with certain optional equipment.

Wiring Color Codes
(Unless otherwise marked)

Right Most Digit of Wire Number	Color of Wire
0	Tan
1	Pink
2	Brown
3	Orange
4	Yellow
5	Green
6	Blue
7	Purple
8	Gray
9	White

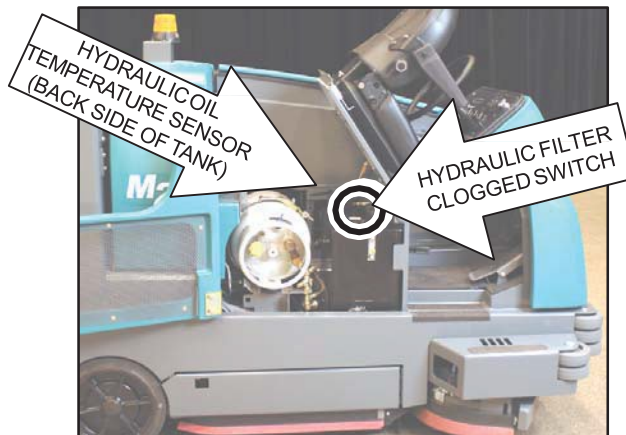

Engine Oil Pressure, Temperature, and MIL System

Condition: Key Turned To Run Position - (Gas / LP) -

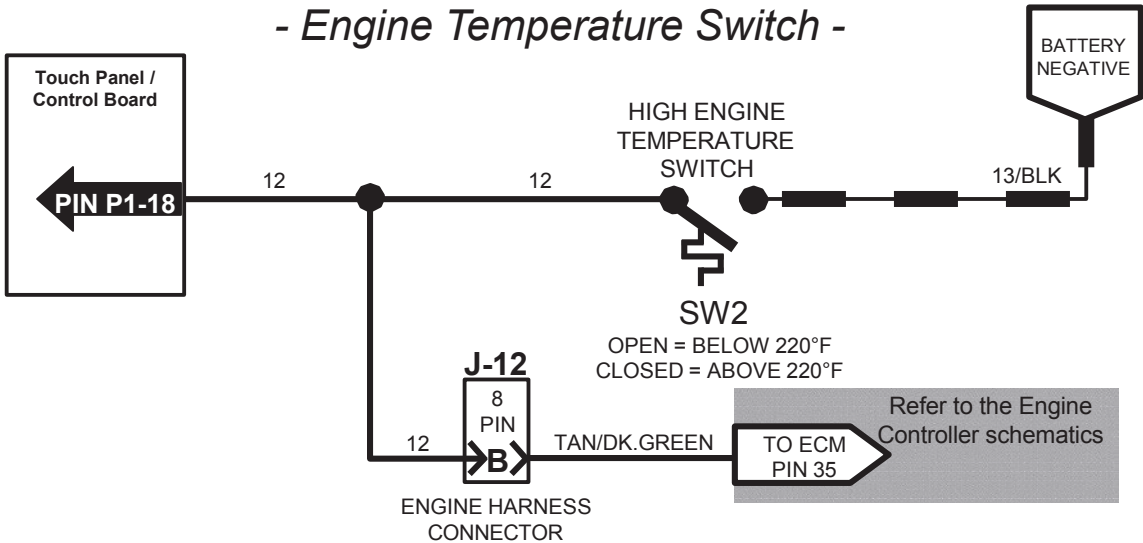
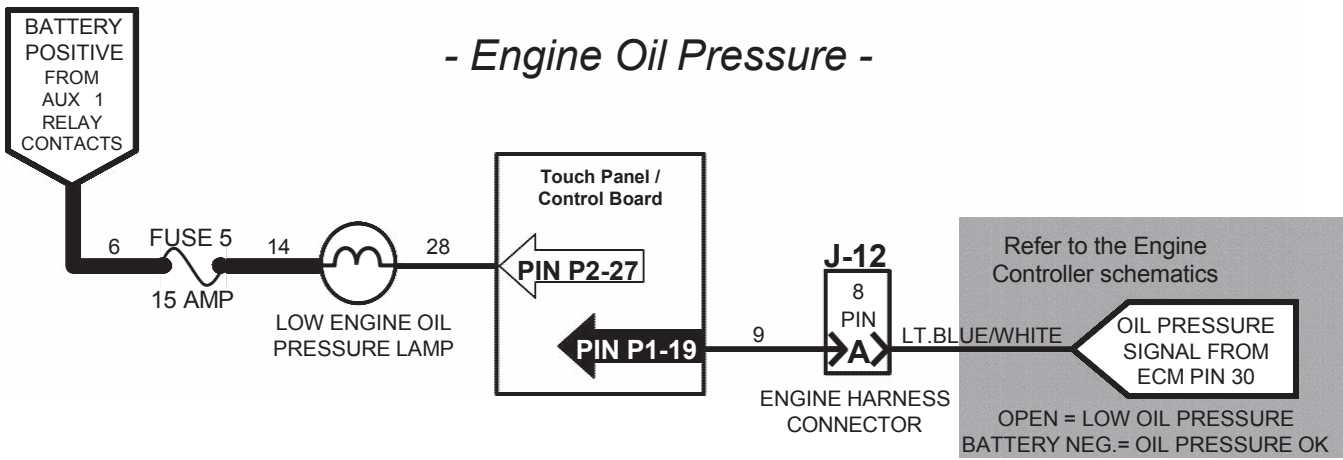

- Malfunction Indicator Lamp -

Wiring Color Codes
(Unless otherwise marked)

Right Most Digit of Wire Number	Color of Wire
0	Tan
1	Pink
2	Brown
3	Orange
4	Yellow
5	Green
6	Blue
7	Purple
8	Gray
9	White

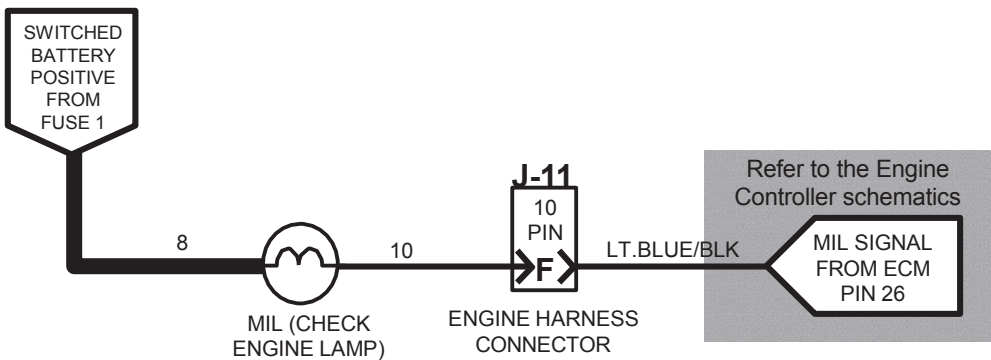

Engine Oil Pressure and Temperature Sensor

Condition: Key Turned to Run Position - (Diesel) -

- Engine Oil Pressure Switch -

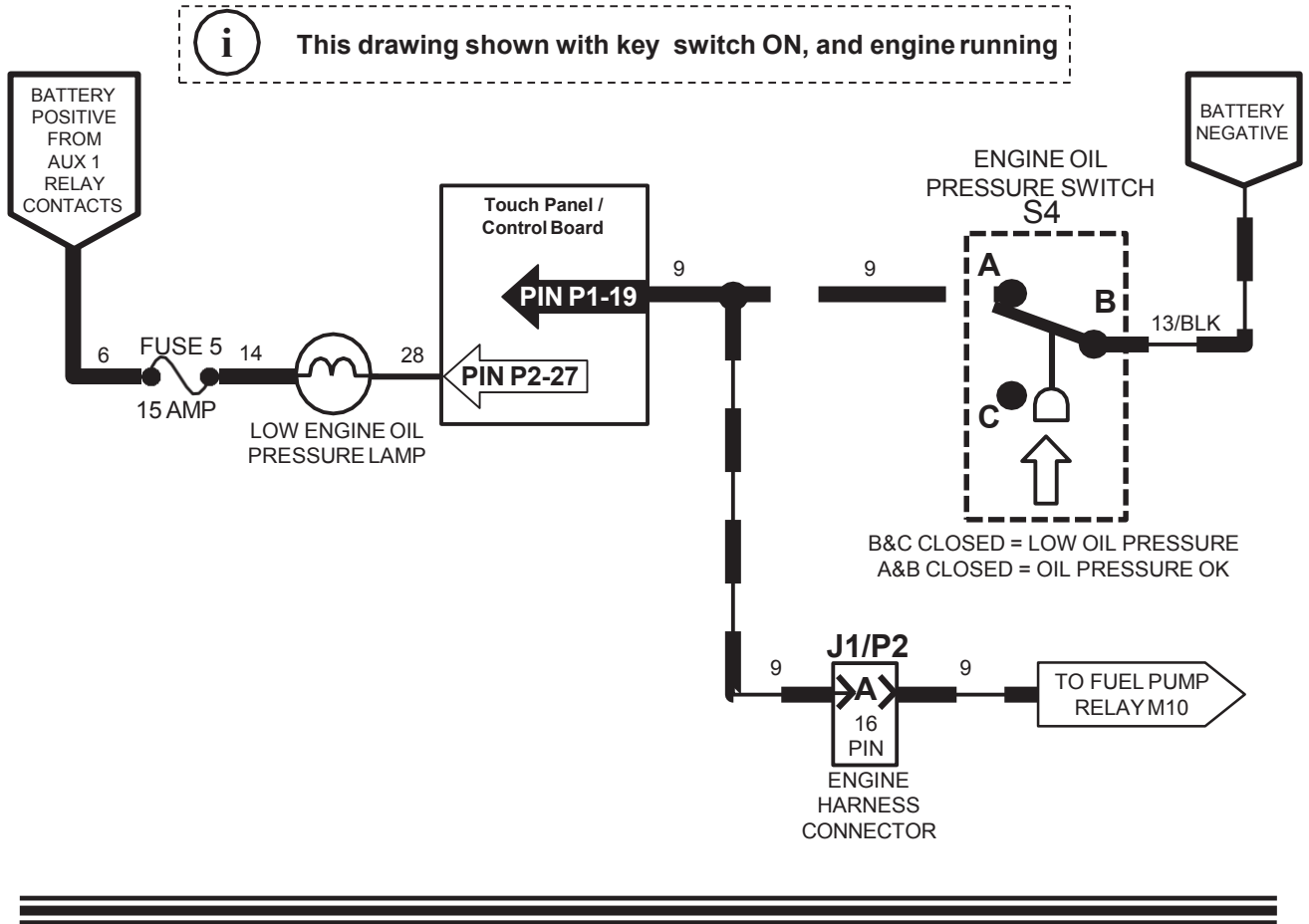

- Engine Temperature Switch -

Wiring Color Codes
(Unless otherwise marked)

Right Most Digit of Wire Number	Color of Wire
0	Tan
1	Pink
2	Brown
3	Orange
4	Yellow
5	Green
6	Blue
7	Purple
8	Gray
9	White

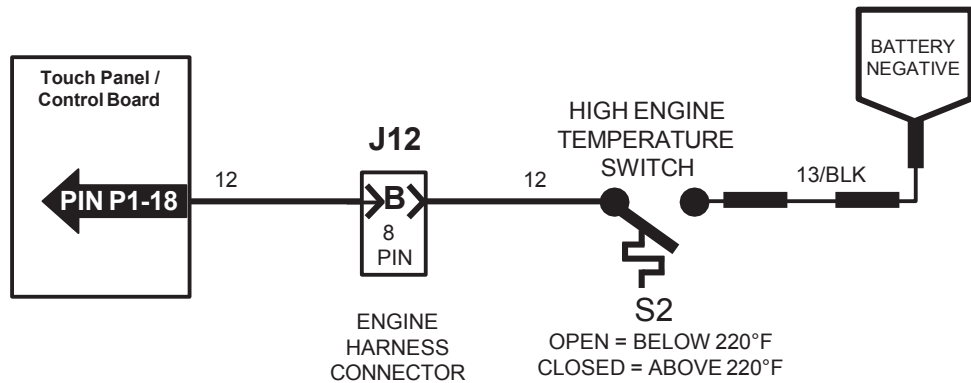

Fuel Pump and Speed Control Output

Condition: Key On Engine Running - (Gas / LP) -

i This drawing is shown with key switch ON, and engine running.

- Fuel Pump (Gas Only) -

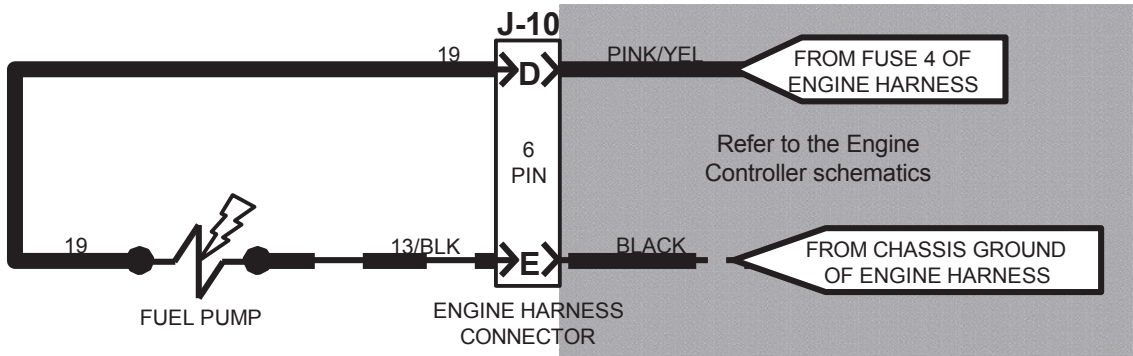

- Speed Control Output -

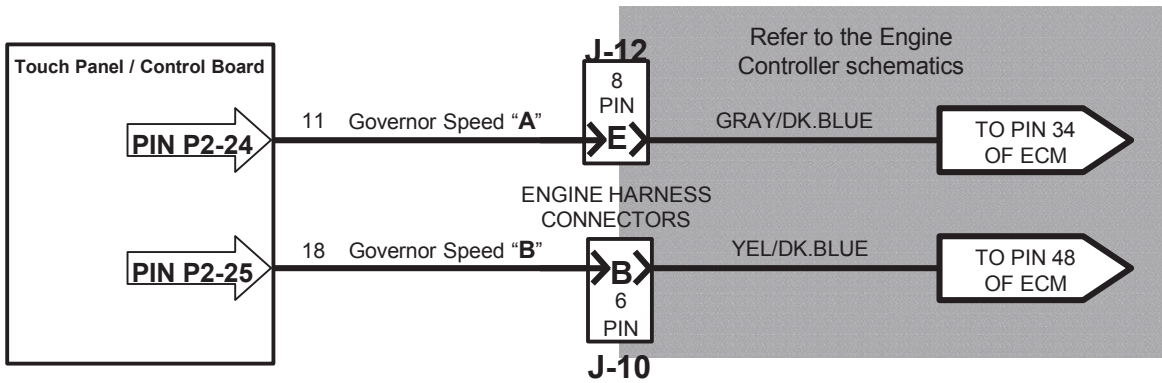

Wiring Color Codes
(Unless otherwise marked)

Right Most Digit of Wire Number	Color of Wire
0	Tan
1	Pink
2	Brown
3	Orange
4	Yellow
5	Green
6	Blue
7	Purple
8	Gray
9	White

Speed Control		T20	M20	M30
Diesel	Idle	950 +/- 50 RPM	950 +/- 50 RPM	1350 +/- 50 RPM
	Run	2400 +/- RPM	2400 +/- RPM	2800 +/- 50 RPM
LP / Gas	Idle	1350 +/- 50 RPM	1350 +/- 50 RPM	1350 +/- 50 RPM
	Run	2300 +/- 50 RPM	2300 +/- 50 RPM	2300 +/- 50 RPM

Fuel Pump

Condition: Key On Engine Running - (Diesel) -

i This drawing is shown with key switch ON, and engine running.

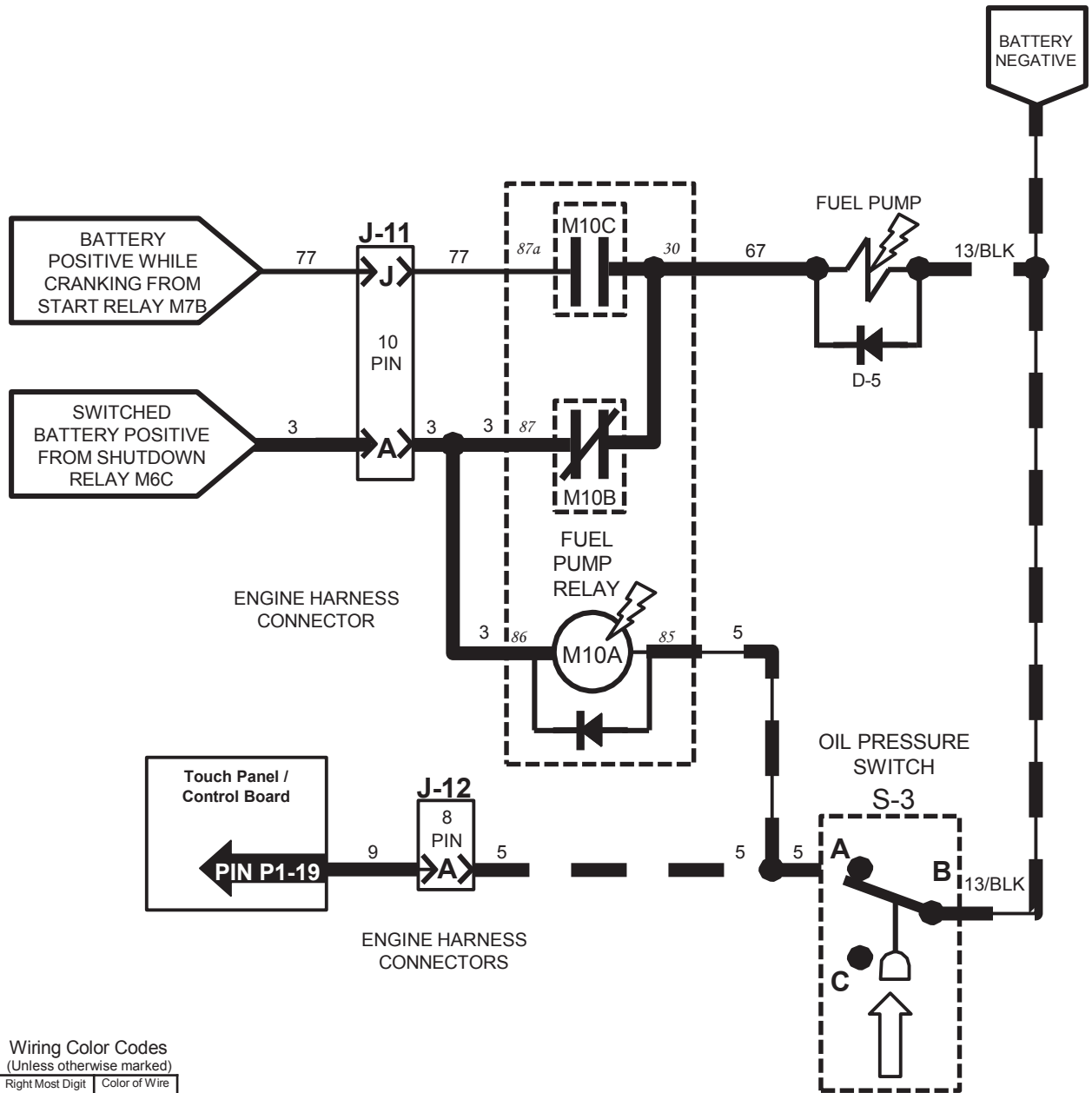

B&C CLOSED = LOW OIL PRESSURE
A&B CLOSED = OIL PRESSURE OK

Wiring Color Codes
(Unless otherwise marked)

Right Most Digit of Wire Number	Color of Wire
0	Tan
1	Pink
2	Brown
3	Orange
4	Yellow
5	Green
6	Blue
7	Purple
8	Gray
9	White

Engine Speed Control

Condition: Key On Engine Running - (Diesel) -

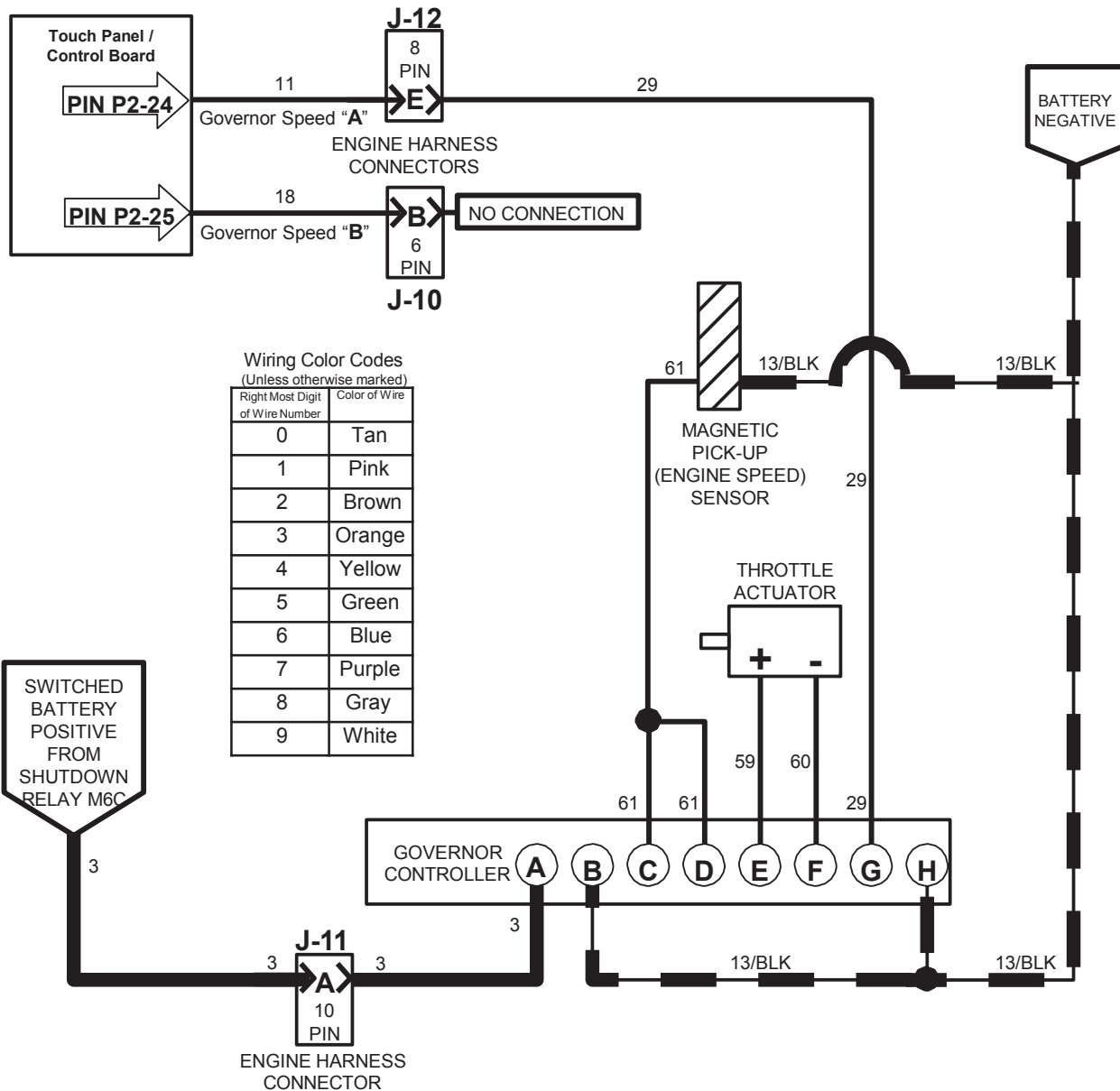

pin	description
A	INPUT – Battery Positive
B	INPUT – Battery Negative
C	INPUT – Engine Speed Sensor
D	INPUT – Engine Speed Sensor
E	OUTPUT – Throttle Actuator (PWM)
F	OUTPUT – Throttle Actuator
G	INPUT – Engine Speed Selection “A”
H	INPUT – Engine Speed Selection “B”

Speed Control		T20	M20	M30
Diesel	Idle	950 +/- 50 RPM	950 +/- 50 RPM	1350 +/- 50 RPM
	Run	2400 +/- RPM	2400 +/- RPM	2800 +/- 50 RPM
LP / Gas	Idle	1350 +/- 50 RPM	1350 +/- 50 RPM	1350 +/- 50 RPM
	Run	2300 +/- 50 RPM	2300 +/- 50 RPM	2300 +/- 50 RPM

M₂ Series Enable / Disable Chart

M20 Control Board Inputs and the Outputs they Control	Input	Fuel Level Sender (Gas, Diesel)	Fuel Pressure Switch Closed (LFO)	Solution Tank Full Switch Closed	Recovery Tank Full Switch Closed	Recovery Tank Half Full Switch Closed	Clogged Hydraulic Filler Switch Closed	Solution Tank Empty Switch Closed	Hydraulic Oil Temperature Sensor above 230F	Impact Sensor Closed	Propel Pedal Sensor FORWARD	Propel Pedal Sensor REVERSE	Propel Pedal Sensor NEUTRAL	Touch Panel Input(s) Required to ENABLE	Touch Panel Input(s) Required to DISABLE	Notes
Output	Component #	S-7	S-8	S-14	S-15	S-16	S-17	S-19	S-20	S-23	n/a	n/a	n/a			
Scrub Vacuum Fan Valve ON	SV-1	P1-4	P1-4	P1-12	P1-13	P1-14	P1-15	P1-11	P1-17	P1-21	P1-1	P1-1	P1-1			
Main Brush Head Down Pressure Valve ON	SV-2				D									OneStep Scrub OFF; Squeegee/Scrub Vacuum OFF; Low Engine Speed Selected		Propel required to get full operational down pressure
Main Brush Head Lower Valve ON	SV-3				D					E	see notes	E	Refer to Notes	OneStep Scrub OFF; Squeegee/Scrub Vacuum OFF; Low Engine Speed Selected		Propel required to get full operational down pressure
Rear and Side Squeegees Lower Valve ON	SV-4				D					E	see notes	E	Refer to Notes	OneStep Scrub OFF; Squeegee/Scrub Vacuum OFF		Propel required to get full operational down pressure
Main Brushes Spin Valve ON	SV-6				D					E	see notes	E	Refer to Notes	OneStep Scrub OFF; Low Engine Speed Selected		Propel required to get full operational down pressure
Hydraulic Enable Valve ON	SV-7													Refer to Notes		Turns OFF automatically if not required (SV-7 is required for all hydraulic functions EXCEPT sweep and scrub vacuum fans)
Side Brush Spin Valve ON	SV-8				D									OneStep Scrub OFF; Low Engine Speed Selected; Side Brush OFF		
Side Brush Down Pressure Valve ON	SV-10				D									OneStep Scrub OFF; Low Engine Speed Selected; Side Brush OFF		
Side Brush Lower Valve ON	SV-11				D									OneStep Scrub OFF; Low Engine Speed Selected; Side Brush OFF		
Side Brush Extend Valve ON	SV-12				D									OneStep Scrub OFF; Low Engine Speed Selected; Side Brush OFF		
Auto-Fill Solution Tank Valve ON	SOL-1															
Auto-Fill Recovery Tank Valve ON	SOL-2					D										
Main Brushes Solution Valve ON	SOL-3				D											
ES Pump ON OR FaST Enable Valve, Air Pump & Water Pump Relay ON	SOL-4, M11			D	D	E										
FaST High Flow Valve ON	SOL-5				D											
FaST Side Brush Valve ON	SOL-6				D											
Side Brush Solution Valve ON	SOL-7				D											
Reverse Propel Relay ON	M4A															
Shut Down Relay ON	M6A															
Detergent Pump ON OR FaST Detergent Pump ON	n/a				D											
Audible Alarm	n/a	E	E				E	E	E							
Low Engine Oil Pressure Lamp	n/a	when low	when low													If low oil pressure, engine ECM will shutdown the engine after a time delay
Governor Speed Bit "A"	n/a															
Governor Speed Bit "B"	n/a															

E = Input required to ENABLE output D = Input req

M_Series Control Board Connectors

socket #	wire #	color	type	goes to
P1-1	91	pink	input	Forward/Reverse Propel Sensor
P1-2	13	black	input	Unswitched Battery Negative
P1-3	x	x	x	empty
P1-4	30	tan	input	S-7 or S-8 Fuel Level Sensor or LPG Pressure Switch
P1-5	x	x	x	empty
P1-6	x	x	x	empty
P1-7	x	x	x	empty
P1-8	x	x	x	empty
P1-9	x	x	x	empty
P1-10	x	x	x	empty
P1-11	177	purple	input	S-19 Solution Tank Empty Switch
P1-12	44	yellow	input	S-14 Solution Tank Full Switch
P1-13	45	green	input	S-15 Recovery Tank Full Switch
P1-14	46	blue	input	S-16 Recovery Tank Half Full Switch
P1-15	90	tan	input	S-17 Clogged Hydraulic Filter Switch
P1-16	x	x	x	empty
P1-17	78	gray	input	S-20 Hydraulic Temperature Sensor
P1-18	12	brown	input	SW2 High Engine Temperature Switch
P1-19	9	white	input	Engine Oil Pressure Signal
P1-20	x	x	x	empty
P1-21	49	white	input	S-23 Impact Sensor
P1-22	x	x	x	empty
P1-23	105	green	ground	Static Ground

Connector P1

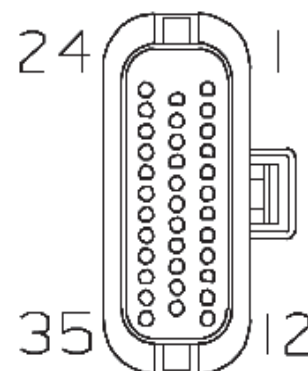

i Viewed from wire side of connector.

socket #	wire #	color	type	goes to
P2-1	14	yellow	power	Switched Battery Positive
P2-2	14	yellow	power	Switched Battery Positive
P2-3	81	pink	power	Unswitched Battery Positive
P2-4	57	purple	output	SV-2 Brush Head Pressure Solenoid Valve
P2-5	58	gray	output	SV-3, SV-6 Brush Head Down & ON Solenoid Valves
P2-6	59	white	output	SV-4 Squeegees Down Solenoid Valve
P2-7	x	x	x	empty
P2-8	61	pink	output	SV-7 Hydraulic Enable Solenoid Valve
P2-9	62	brown	output	SV-8, SV-12 Side Brush ON & Down Solenoid Valves
P2-10	x	x	x	empty
P2-11	64	yellow	output	SV-10 Side Brush Pressure Solenoid Valve
P2-12	66	blue	output	SV-11 Side Brush Down Solenoid Valve
P2-13	65	green	output	SOL-1 Solution Tank Auto Fill Water Valve
P2-14	67	purple	output	SOL-2 Recovery Tank Auto Fill Water Valve
P2-15	x	x	x	empty
P2-16	x	x	x	empty
P2-17	70	tan	output	M4A Reverse Relay
P2-18	71	pink	output	M6A Shutdown Relay
P2-19	72	brown	output	SOL-3 Main Brush Head Water Valve
P2-20	181	pink	output	SOL-7 Side Brush Water Valve
P2-21	74	yellow	output	Detergent Pump or FaST Pressure Switch
P2-22	75	green	output	SOL-4, M11A ES Pump or FaST Enable Valve, Air Pump, Water Pump Relay
P2-23	79	white	output	SOL-5 FaST High Flow Valve
P2-24	11	pink	output	ECM (Governor Speed Bit "A")
P2-25	18	gray	output	ECM (Governor Speed Bit "B")
P2-26	80	tan	output	SOL-6 FaST Side Brush Valve
P2-27	28	gray	output	Low Engine Oil Pressure Lamp
P2-28	56	blue	output	SV-1 Scrub Vacuum Fan Valve
P2-29	182	brown	output	Audible Alarm
P2-30	x	x	x	empty
P2-31	x	x	x	empty
P2-32	x	x	x	empty
P2-33	13	black	ground	Unswitched Battery Negative
P2-34	13	black	ground	Unswitched Battery Negative
P2-35	13	black	ground	Unswitched Battery Negative

Connector P2

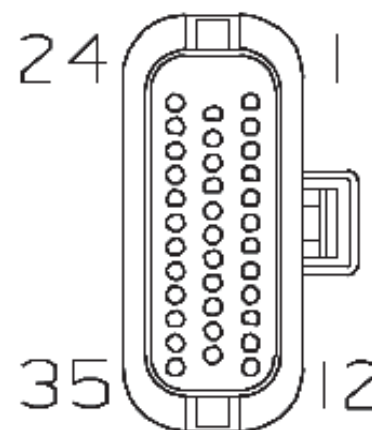

i Viewed from wire side of connector.

M_Series Fault Condition Chart

The following table describes fault codes communicated to the operator. A fault code is indicated by blinking a Fault LED (red), sounding an alarm, and also by displaying the fault name on the LCD. Faults can be cleared when they are no longer present **and** one of the action buttons (i.e. One-Step) is depressed. If there is more than one fault, they are displayed for about a second one after the other.

Fault	LCD Display	Description
Hydraulic Filter Clogged	F3: CLOGGED HYD	Indicates the hydraulic filter is clogged.
Solution Tank empty	F6: SOL. TANK E	Indicates the solution tank is empty.
Recovery Tank Full	F7: REC. TANK FULL	Indicates the recovery tank is full and shuts down the entire Scrub system.
High Engine Temperature	F8: HIGH ENG TEMP	Indicates high engine temperature.
High Hydraulic Temperature	F9: HIGH HYD TEMP	Indicates excessive hydraulic temperature
Low Fuel	F10: LOW FUEL	Low fuel indicator (blinking lowest fuel gauge block).
Squeegee Disconnected (Option)	F11: OPEN SCB VAC	Indicates squeegee may have broken free.

M_Series Condition and Warning Indicators

The following table describes displayed conditions or warnings. If a condition is sensed, the condition or warning code will be displayed on the LCD. Conditions are typically caused by activating buttons that are unavailable. For example: the Sweep vacuum fan is unavailable when the scrub functions are active.

Condition	LCD DISPLAY	Description
FaST system is selected by the operator and the machine is not configured with the FaST option.	C3: NO FAST MODE	Only machines with the FaST system installed (and programmed to be FaST machines) can turn ON the FaST system.
ES system is selected by the operator and the machine is not configured with the ES option.	C4: NO ES MODE	Only machines with the ES system installed (and programmed to be ES machines) can turn ON the ES system.
FaST or ES system is selected by the operator and the machine is not configured with the ES or FaST option.	C5: NO ES/FAST	Only machines with the ES or FaST system installed (and programmed to be ES or Fast machines) can turn ON the ES or FaST system.
Side Brush button is activated alone without 1-STEP Sweep/Scrub.	C6: NO SIDE BRUSH	The T20 machine is NOT programmed to operate with only the side brush ON.

HYDRAULIC

Troubleshooting Information

- BEFORE CONDUCTING TESTS:
 - * Read and Follow ALL Safety Warnings and Precautions as mentioned at the beginning of this manual
 - * Engine & Hydraulic Oil Must Be At Normal Operating Temperatures after Running Machine and Hydraulics a Minimum of 5 Minutes
 - * Examine Machine For Any Linkage Binding or Mechanical Problems

- DURING TESTS:
 - * Call Technical Services if Diagnostic Time Exceeds One Hour With Unknown Cause or Course of Action
 - * Maintain Normal Main Brush Pressure as Listed in Operator's Manual

NOTE: Troubleshooting charts may be shown with optional equipment. The optional equipment may not be specified in these charts. Some machines may not be equipped with all components shown.

General Information

Page 1 of 2

Commonly Used Hydraulic Symbols

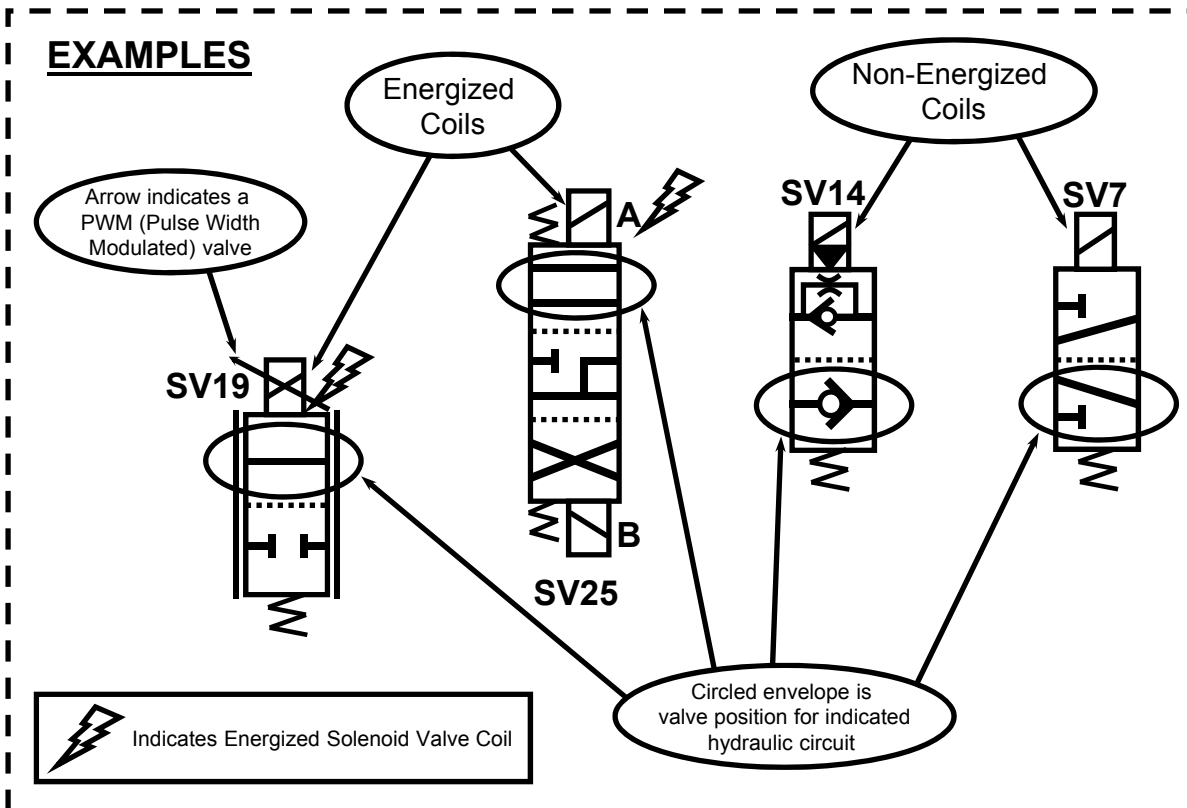
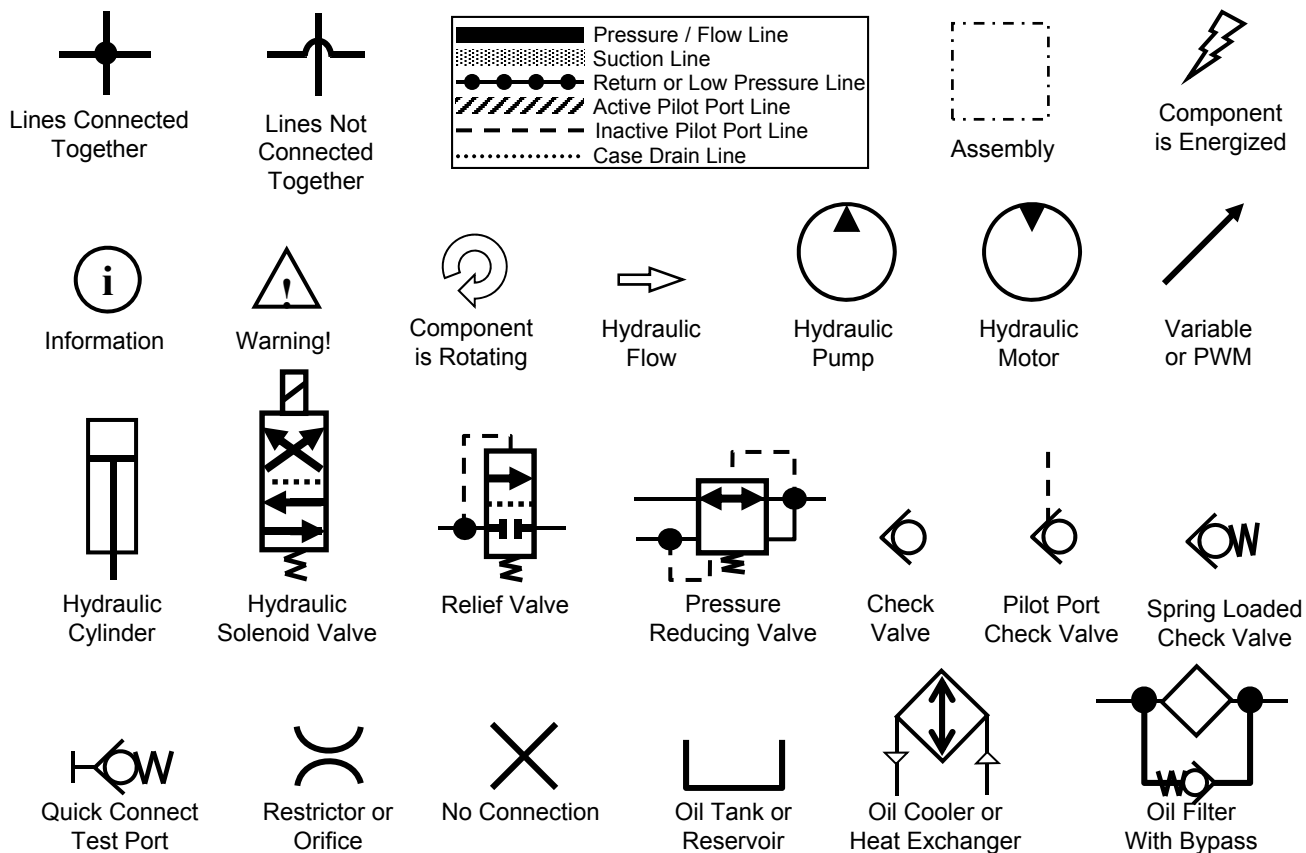

General Information

Page 2 of 2

Hydraulic Pump Flow Rates (typical)

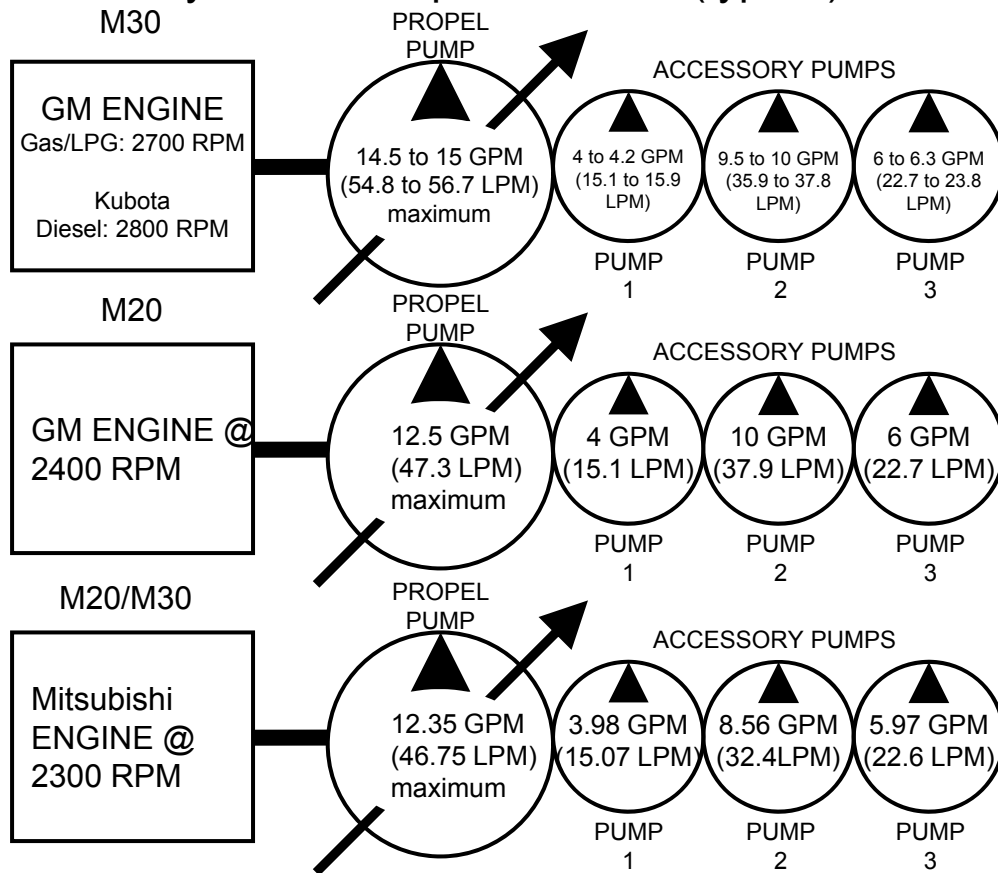

Commonly Used Abbreviations

AUX	Auxiliary
CIR	Cubic Inch Displacement per Revolution
CK	Check Valve
CM	Centimeters
CONV	Conveyor
CU	Cubic
CV	Control Valve
CYL	Cylinder
DC	Disconnect Coupler (Hydraulic)
DC	Direct Current (Electrical)
E	Engine (Combustion)
FLTR	Filter
GPM	Gallons Per Minute
HTX	Heat Exchanger
IN	Inches
LH	Left Hand
LPM	Liters Per Minute
LS	Load Sense
M	Motor (Combustion)

MFLD	Manifold
MTR	Motor (Hydraulic)
OR	Orifice
PC	Pilot Port Check Valve
PMP	Pump
PR	Pressure Relief Valve
PSI	Pounds Per Square Inch
PTO	Power Take Off
PWM	Pulse Width Modulation
RES	Reservoir
RH	Right Hand
RPM	Revolutions Per Minute
RV	Relief Valve
SC	Spring Loaded Check Valve
STRN	Strainer
SV	Solenoid Valve
SW	Switch
TV	Throttle Valve
V	Volts

Typical Hydraulic Manifold Port Markings

C	Hydraulic Cylinder Connection
G	Test Port
LS	Load Sense Port

M	Hydraulic Motor Connection
P	Pump Connection
R or T	Return Port (To Tank)

M20_M30 Operational Matrix

Component/ System	Function	Test Port	Test Port Location	Enable Valve	Energized Coil(s)	Notes	Valve Block	Valve Block Number	Location	Feed Port	Exit Port	Pressure Control in Circuit	Pressure Setting (PSI)
Scrub Head	Down	G1	Main Valve	SV7	SV2, SV3 default	SV2 is PWM controlled; Down pressure varies with current to SV2; SV3 and SV6 tied together electrically	Main Valve	1038566	Left Side, beside vacuum fan	C1	C2	SV2	0 to 800
	Up	G5								C2	C1	RV2	2500
Squeegees, Side and Rear	Down		Main Valve	SV7	SV4 default	Operate Squeegees "Up and Down" using Manual Mode--Monitor pressure at G5	Main Valve	1038566	Left Side, beside vacuum fan	C4	C3	RV2	2500
	Up	G5								C3	C4		
Hopper Door	Closed		Main Valve	SV7	default	Lift Hopper, Operate Hopper Door "Open and Closed" using Manual Mode--Monitor pressure G5	Main Valve	1038566	Left Side, beside vacuum fan	C11	C10	RV2	2500
	Open	G5			SV15					C10	C11		
Main Brushes	Run	G5	Main Valve	SV7	SV6	Operate Main Brushes "On" using Manual Mode--Monitor pressure at G5; SV3 and SV6 tied together electrically	Main Valve	1038566	Left Side, beside vacuum fan	M1	Direct to Tank	RV2	2500
Hopper Lift	Down		Main Valve	SV7	SV13	1100 PSI RV3 keeps hopper pushed tight to frame	Main Valve	1038566	Left Side, beside vacuum fan	C12	C9	RV3	1100
	Up	G5		SV14	RV2							2500	
Scrub Fan	Run	G6	Main Valve	-	SV1		Main Valve	1038566	Left Side, beside vacuum fan	Direct from Pump	T3 (on Side Valve)	RV1	2500
Sweep Fan	Run	G6	Main Valve	-	SV9		On Sweep Fan Motor	53485	On sweep fan motor	M4 (on Main Valve)	T3 (on Side Valve)	On Sweep Fan Motor	1800
Side Brush (Sweep/Scrub)	Run	G6	Main Valve	-	SV8	Operate Side Brush "On" using Manual Mode--Monitor pressure at G6; SV8 and SV12 tied together electrically	Side Valve	1037805	Left front	M2	T6	RV1	2500
Side Brush	Up	G8	Side Valve	SV7	default	SV10 is PWM controlled, Operate Side Brush up and down using Manual Mode; SV8 and SV12 tied together electrically	Side Valve	1037805	Left front	C8	C6	PR1	400
	Down	SV10, SV11			SV10							0 to 800	
	Retract	C5			C7							RV2	2500
	Extend	G7			C5							PR1	100

M20_M30 Option Components

The following chart lists various options and the electrical and/or hydraulic components that are associated with the option. Refer to the “notes” section for any components that are deleted from a standard machine in order to have the installed option.

option	added components	E or H	component #	notes
Side Brush	Side Brush ON Solenoid Valve	E,H	SV-8	
	Side Brush Pressure Solenoid Valve	E,H	SV-10	
	Side Brush Down Solenoid Valve	E,H	SV-11	
	Side Brush Extend Solenoid Valve	E,H	SV-12	
	FaST Side Brush Valve	E	SOL-6	
	Side Brush Water Valve	E	SOL-7	
	Side Brush Manifold	H	x	
	Side Brush Lift Cylinder	H	x	
	Side Brush Extend Cylinder	H	x	
	Side Brush Motor	H	x	
ES (Extended Scrub)	Solution Tank Auto Fill Water Valve	E	SOL-1	If machine has ES option, the following components will <i>not</i> be on the machine: FaST Water Pump, FaST Water Pump Relay (M11), FaST Detergent Pump, FaST Air Pump, FaST Enable Valve (SOL-4), FaST High Flow Valve (SOL-5), FaST Side Brush Valve (SOL-6)
	Recovery Tank Auto Fill Water Valve	E	SOL-2	
	Solution Tank Full Switch	E	S-14	
	Recovery Tank Half Full Switch	E	S-16	
	Detergent Pump	E	x	
	ES Pump	E	x	
Spray Hose	Spray Hose Pump	E	x	
	Spray Hose Relay	E	M12	
	Spray Hose Switch	E	S-25	

E = Electrical Component
H = Hydraulic Component

M20_M30 Hydraulic Component Locator

Side Brush Motor - Sweep Fan Motor - Scrub Fan Motor

Propel Motor - Main Brush Motor - Side Squeegee Lift Cylinder

SIDE BRUSH MOTOR

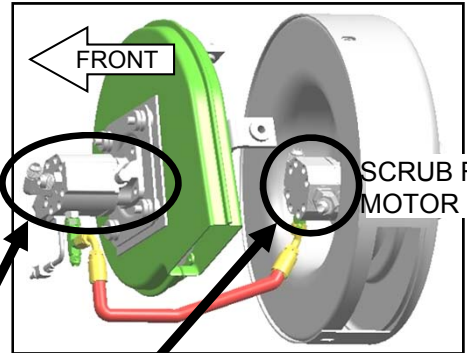
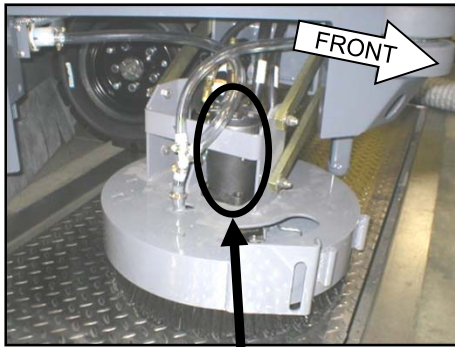

SWEEP FAN MOTOR

SCRUB FAN MOTOR

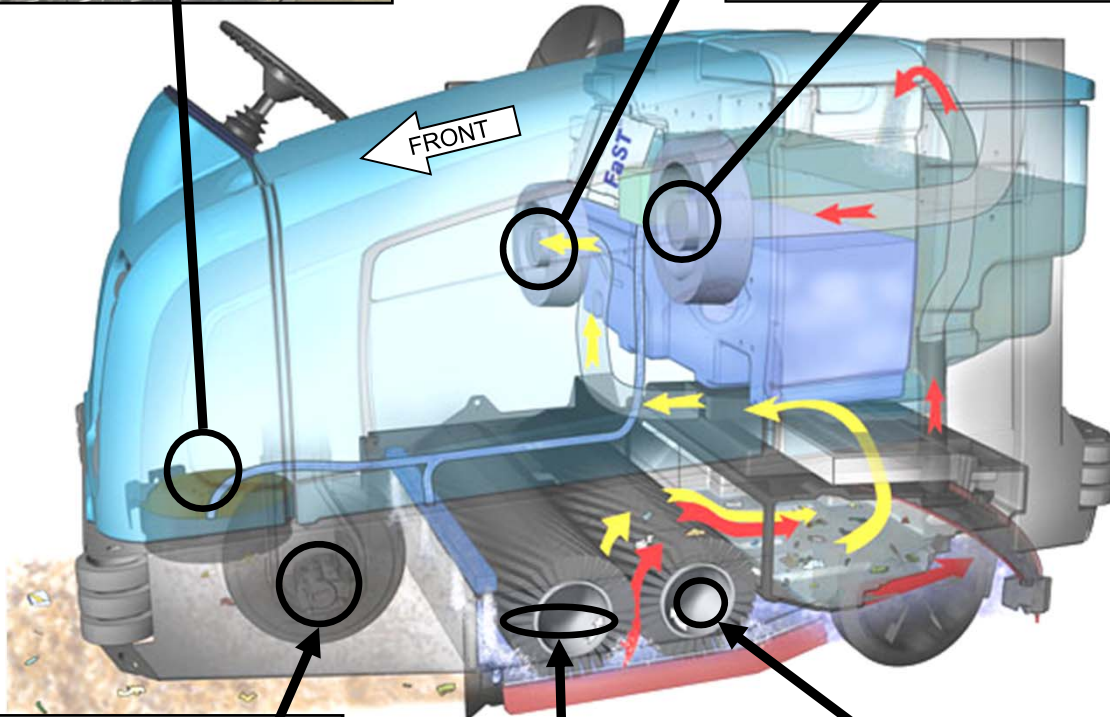

PROPEL MOTOR

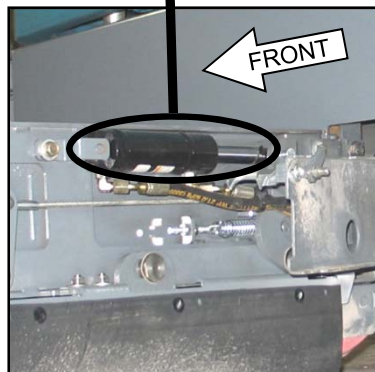

LEFT SIDE SQUEEGEE LIFT CYLINDER

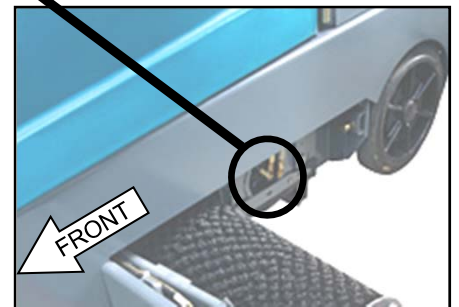

MAIN BRUSH MOTOR (REAR)

M20_M30 Hydraulic Component Locator

Hopper Cylinder - Scrub Head Cylinder - Side Brush Extend Cylinder Cylinder Side Squeegee Cylinder - Main Brush Motor

HOPPER LIFT CYLINDER



SCRUB HEAD LIFT CYLINDER

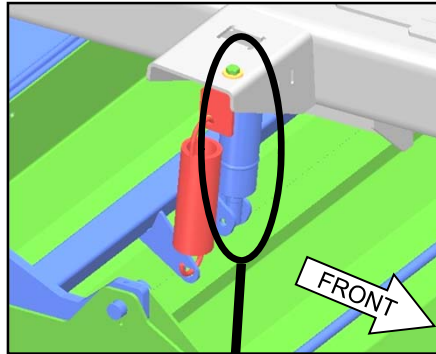

SIDE BRUSH EXTEND CYLINDER

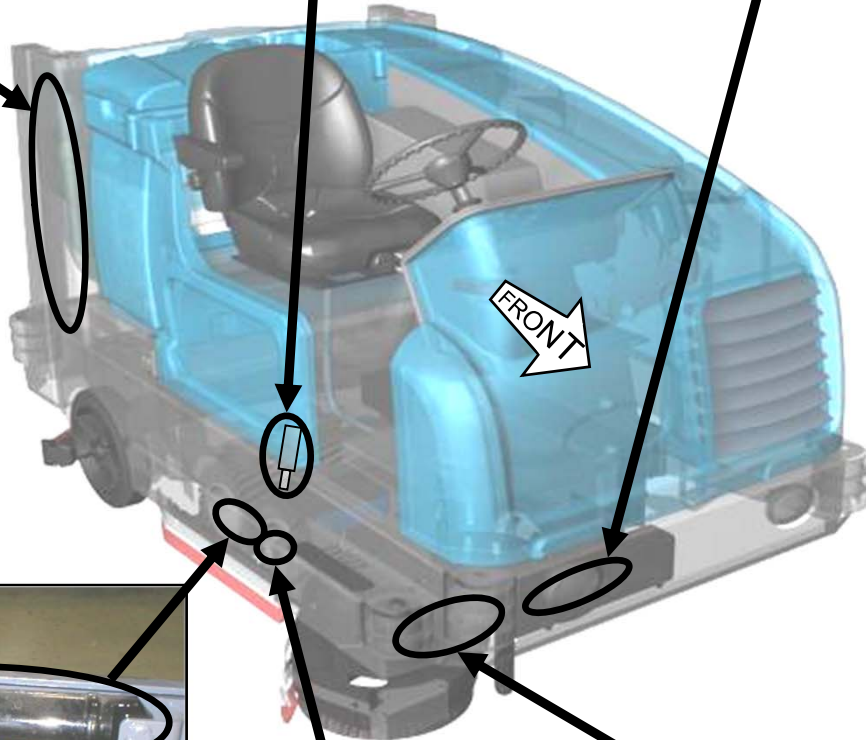
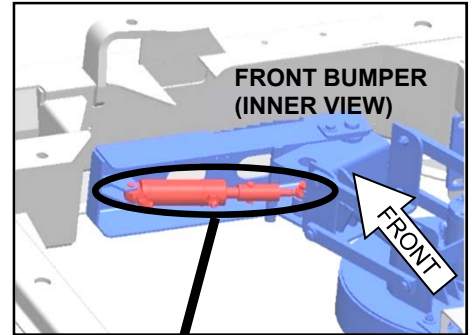

RIGHT SIDE SQUEEGEE LIFT CYLINDER

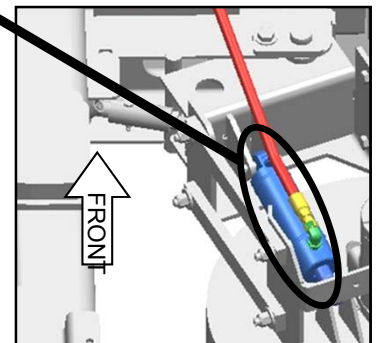

SIDE BRUSH LIFT CYLINDER

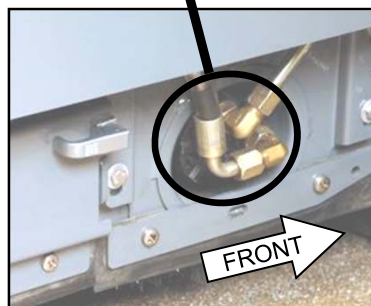

MAIN BRUSH MOTOR (FRONT)

M20_M30 Hydraulic Component Locator

Sweep Fan Valve - Scrub Manifold - Sweep Manifold

SWEEP FAN VALVE SV9
(BESIDE ENGINE FUSE PANEL)

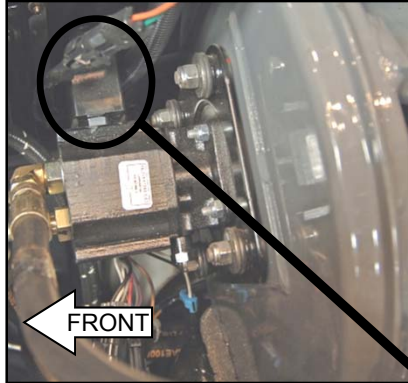

SCRUB MANIFOLD
SV1, SV2, SV3, SV4, SV6, SV7
RV1, RV2, CV1, PC1, PC2

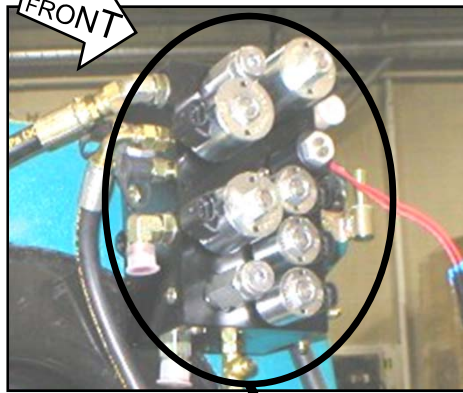

i See pages 00, 00 and 00 for more information on the Scrub, Sweep, and Side Brush manifolds

SWEEP MANIFOLD
SV13, SV14, SV15,
RV3, PC5, PC6

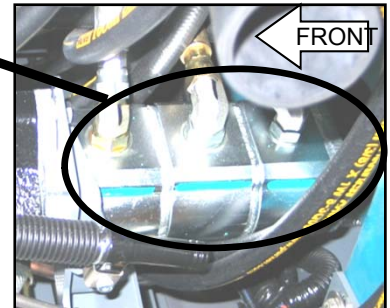
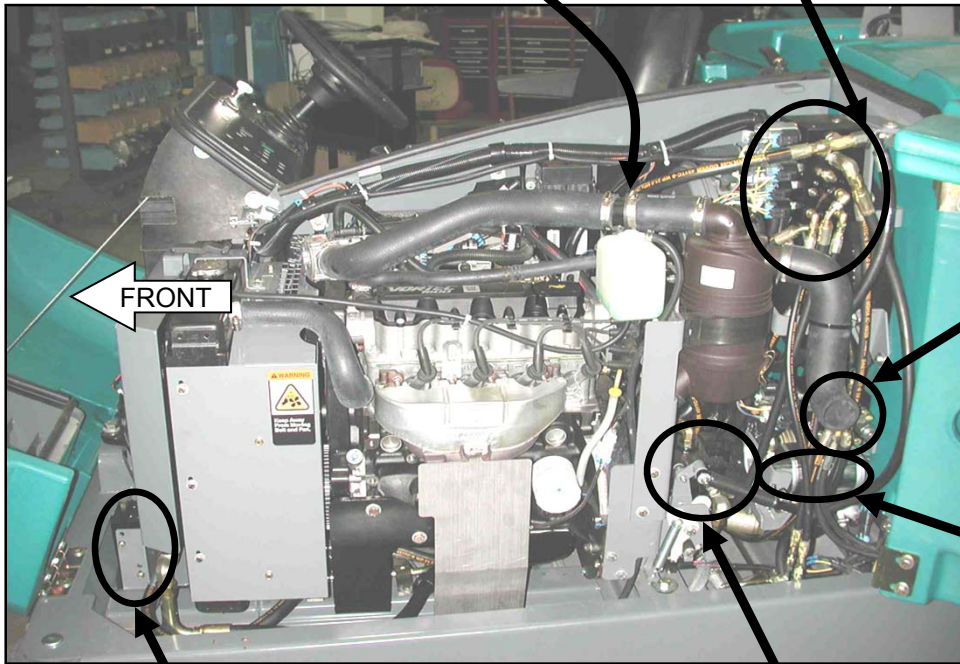
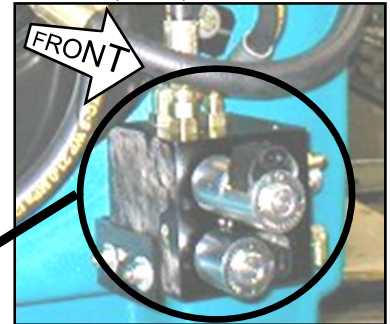

ACCESSORY PUMPS

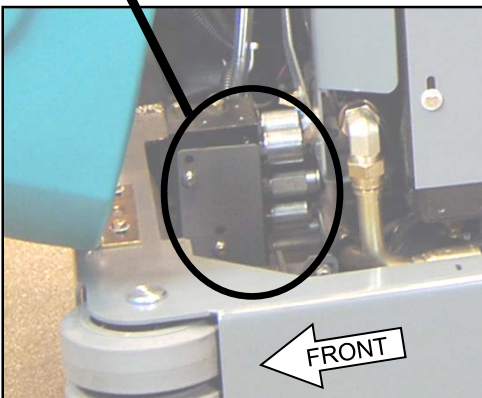

SIDE BRUSH MANIFOLD
SV8, SV10, SV11, SV12, PR1, PC8

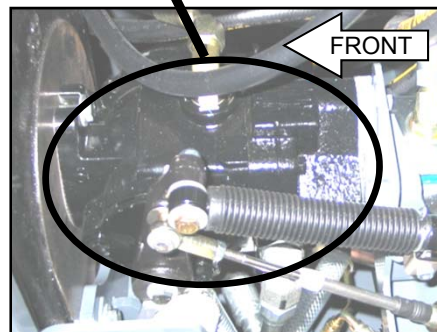

PROPEL PUMP

M20_M30 Hydraulic Component Locator

Steering Cylinder - Hopper Door Cylinder - Rear Squeegee Lift Cylinder

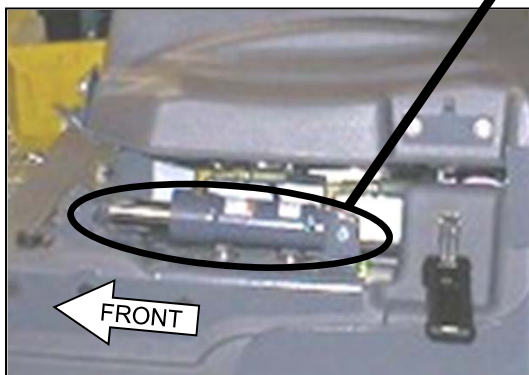
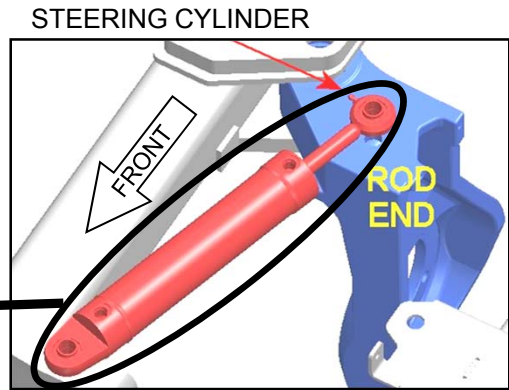
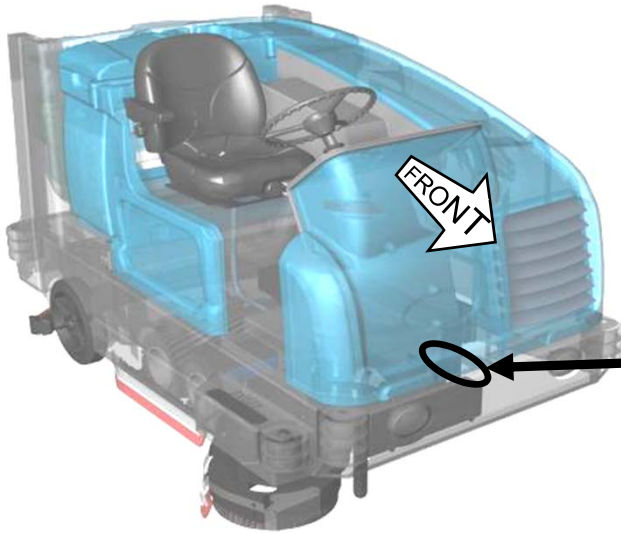

HOPPER DOOR CYLINDER

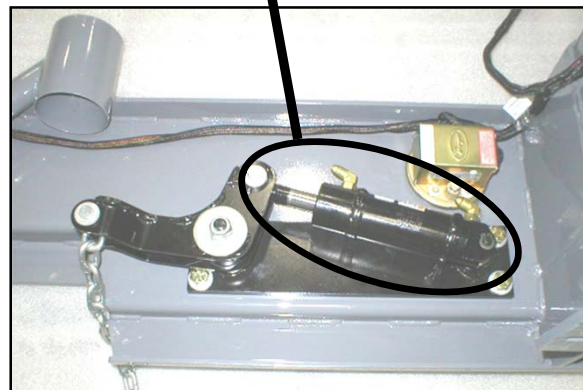

REAR SQUEEGEE LIFT CYLINDER
(VIEWED BEHIND BUMPER)

M20_M30 Hydraulic Component Locator Hose Group - Steering and Propel

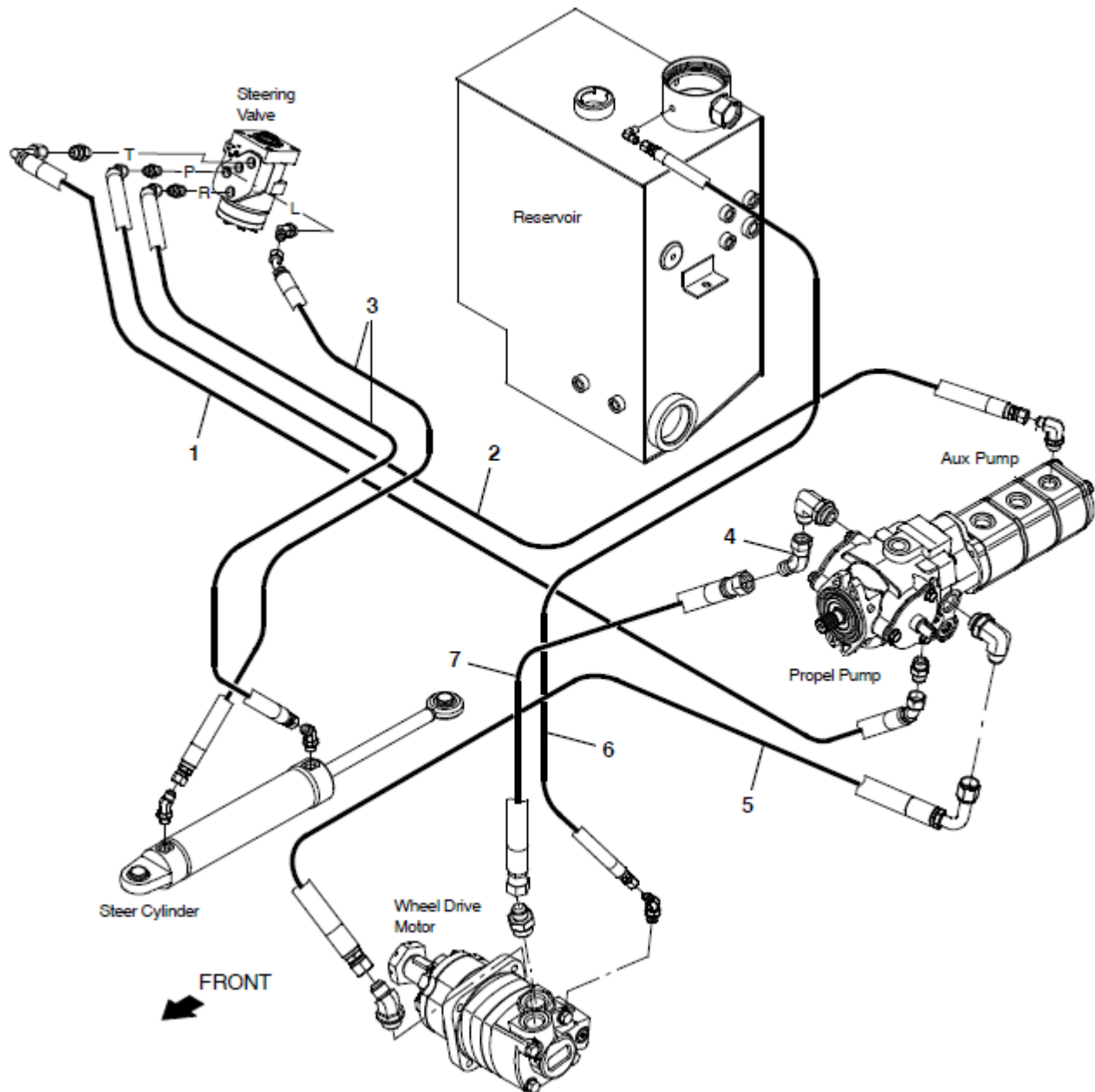

M20_M30 Hydraulic Component Locator Hose Group - Pump and Vacuum Fan

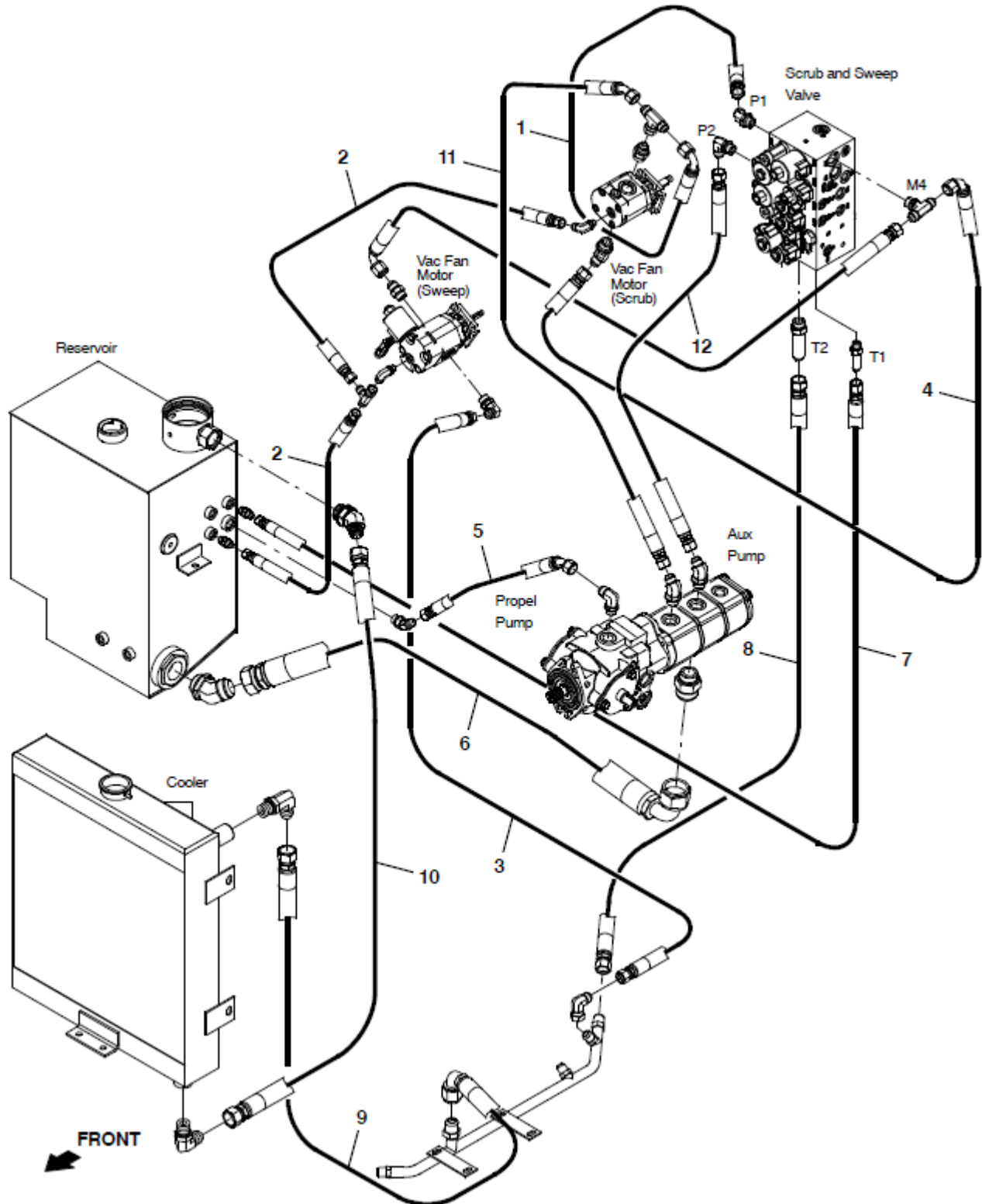

M20_M30 Hydraulic Component Locator Hose Group - Brush and Hopper

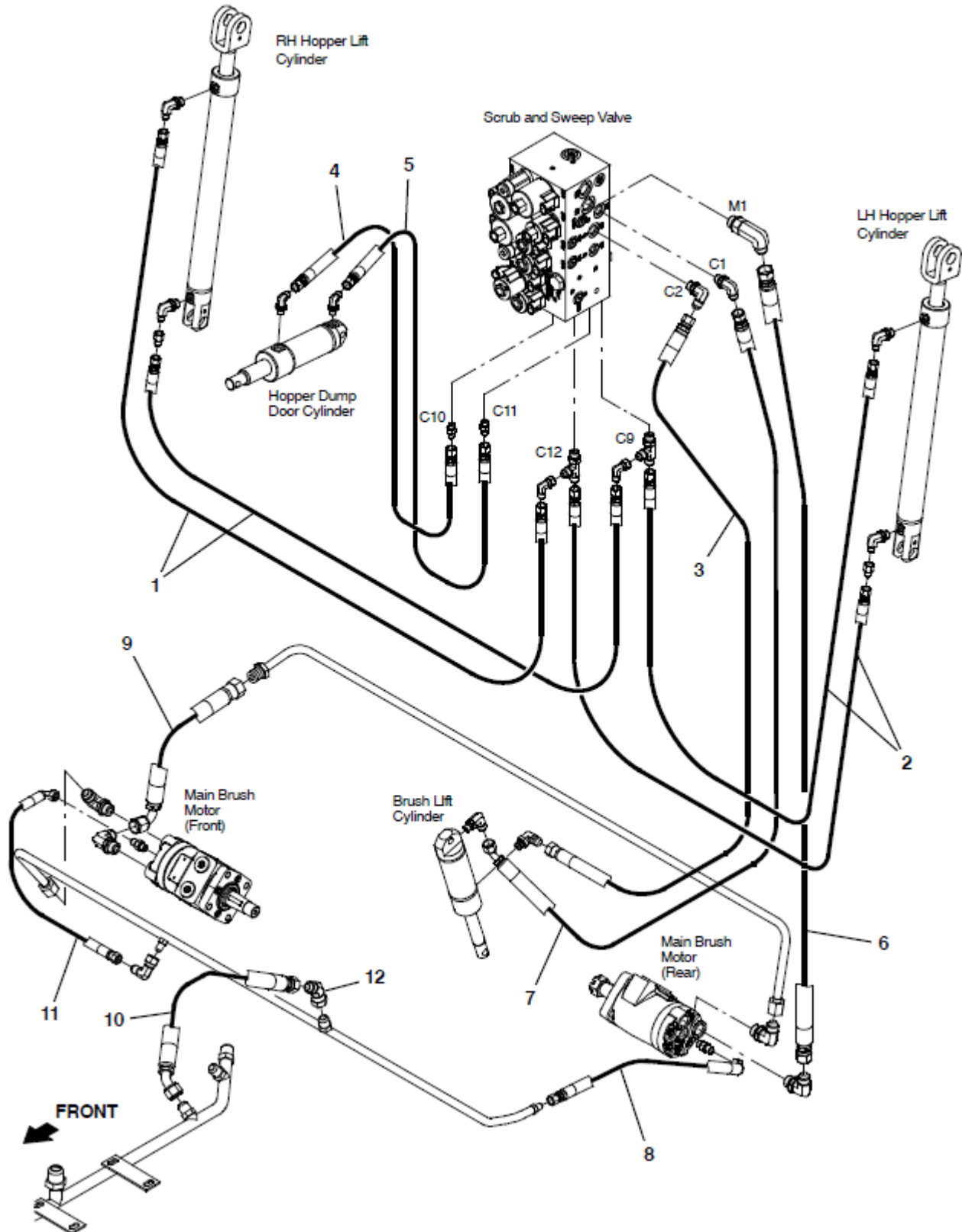

M20_M30 Hydraulic Component Locator Hose Group - Squeegee Lift

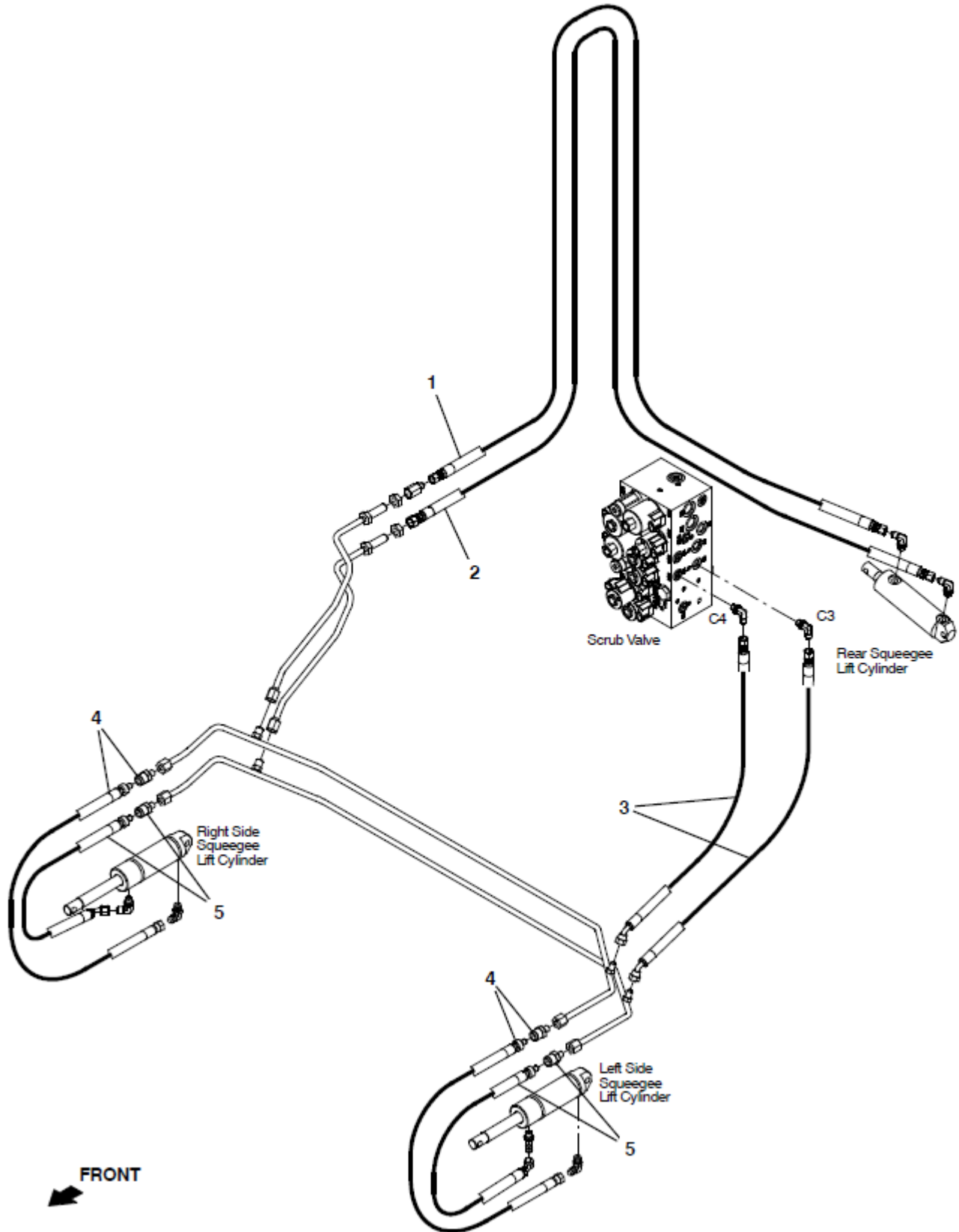

M20_M30 Scrub/Sweep Head Lower

Engine speed: High

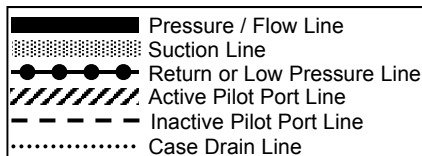

i Gray items are energized or activated

Default M20 SCRUBBING Pressure Readings

# Brush LEDs ON	Pressure at G1
1	95 - 143 psi (6.5 - 9.8 bar)
2	160 - 240 psi (11 - 16.5 bar)
3	280 - 400 psi (19.3 - 27.5 bar)

Default M20 SWEEPING Pressure Readings

# Brush LEDs ON	Pressure at G1
1	6 - 14 psi (0.4 - 1 bar)
2	38 - 56 psi (2.6 - 3.8 bar)
3	73 - 109 psi (5 - 7.5 bar)

Default M30 SCRUBBING Pressure Readings

# Brush LEDs ON	Pressure at G1
1	95 - 143 psi (8.5 - 9.8 bar)
2	180 - 240 psi (11 - 16.5 bar)
3	280 - 400 psi (19.3 - 27.5 bar)

Default M30 SWEEPING Pressure Readings

# Brush LEDs ON	Pressure at G1
1	8 - 14 psi (0.4 - 1 bar)
2	38 - 56 psi (2.6 - 3.8 bar)
3	73 - 109 psi (5 - 7.5 bar)

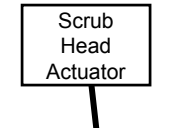
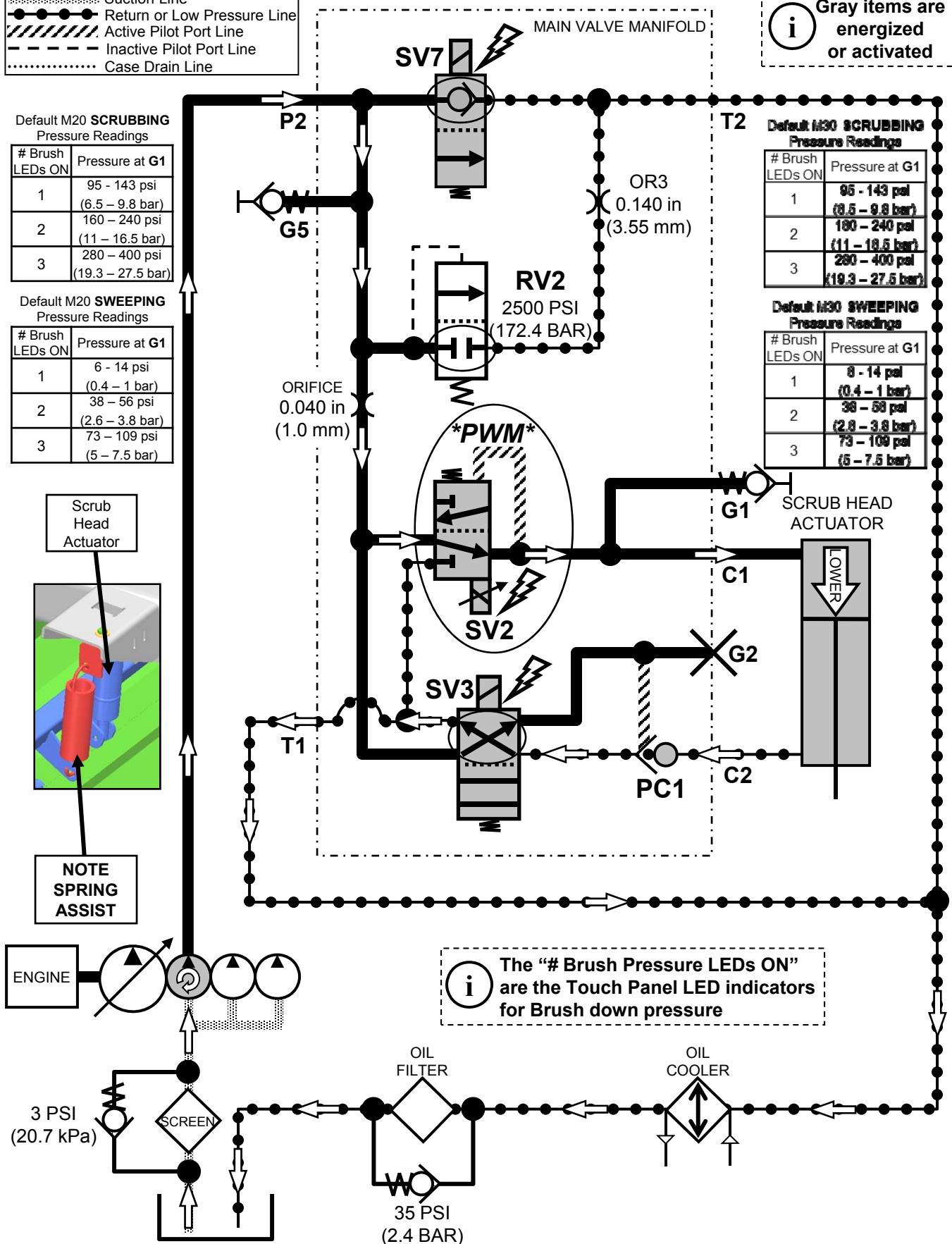

NOTE SPRING ASSIST

i The "# Brush Pressure LEDs ON" are the Touch Panel LED indicators for Brush down pressure

M20_M30 Scrub/Sweep Head Lift

Engine speed: High

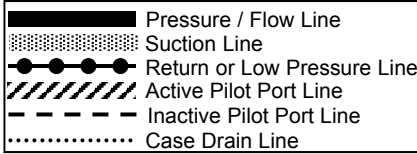

i Gray items are energized or activated

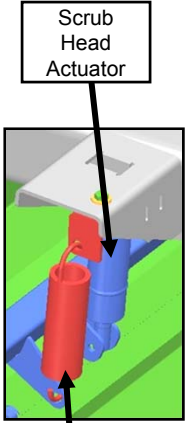
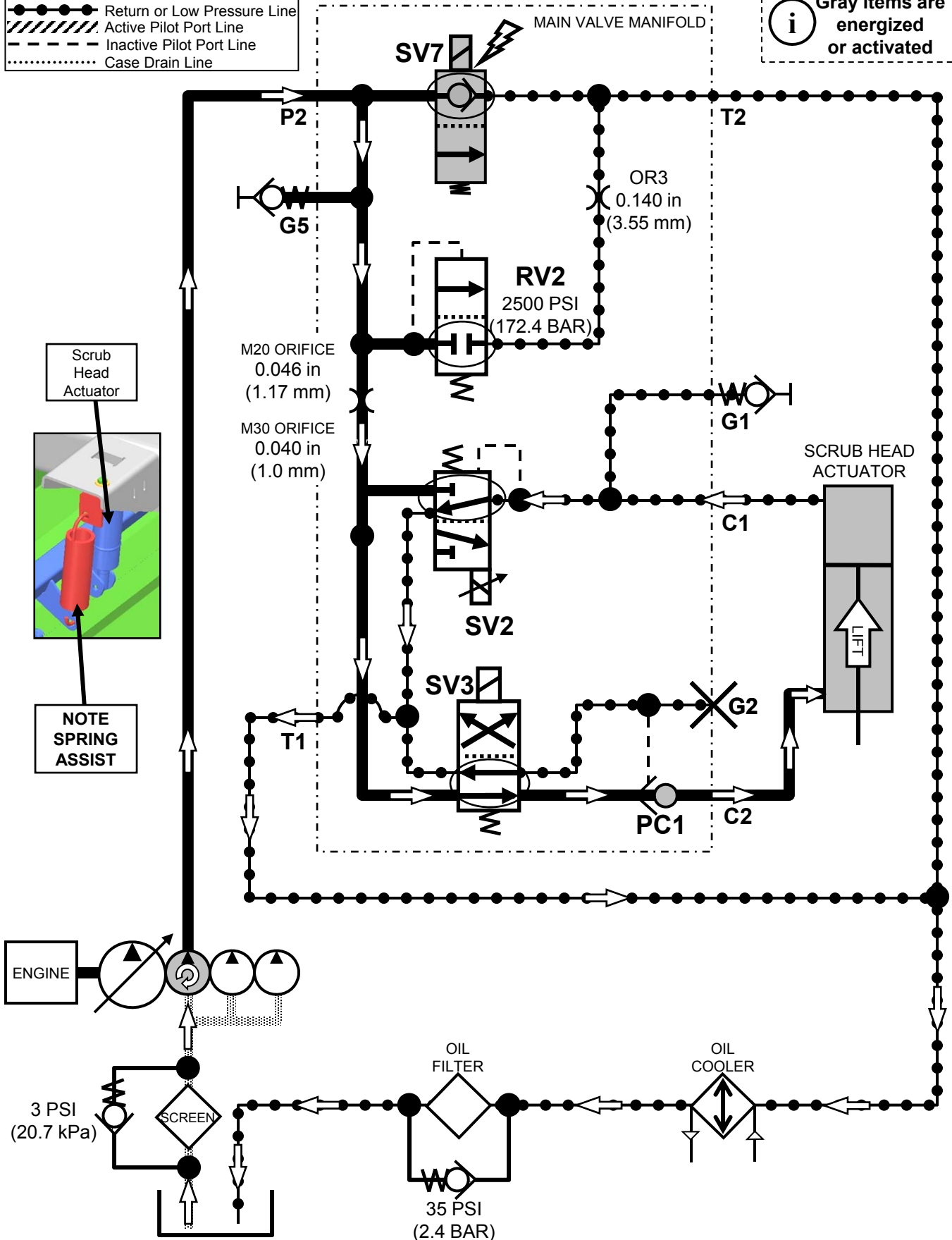

NOTE SPRING ASSIST

M20_M30 Squeegee Lower

Engine speed: High

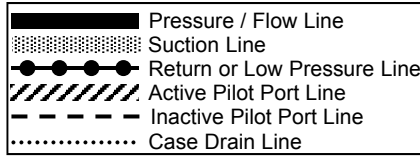

i Gray items are energized or activated

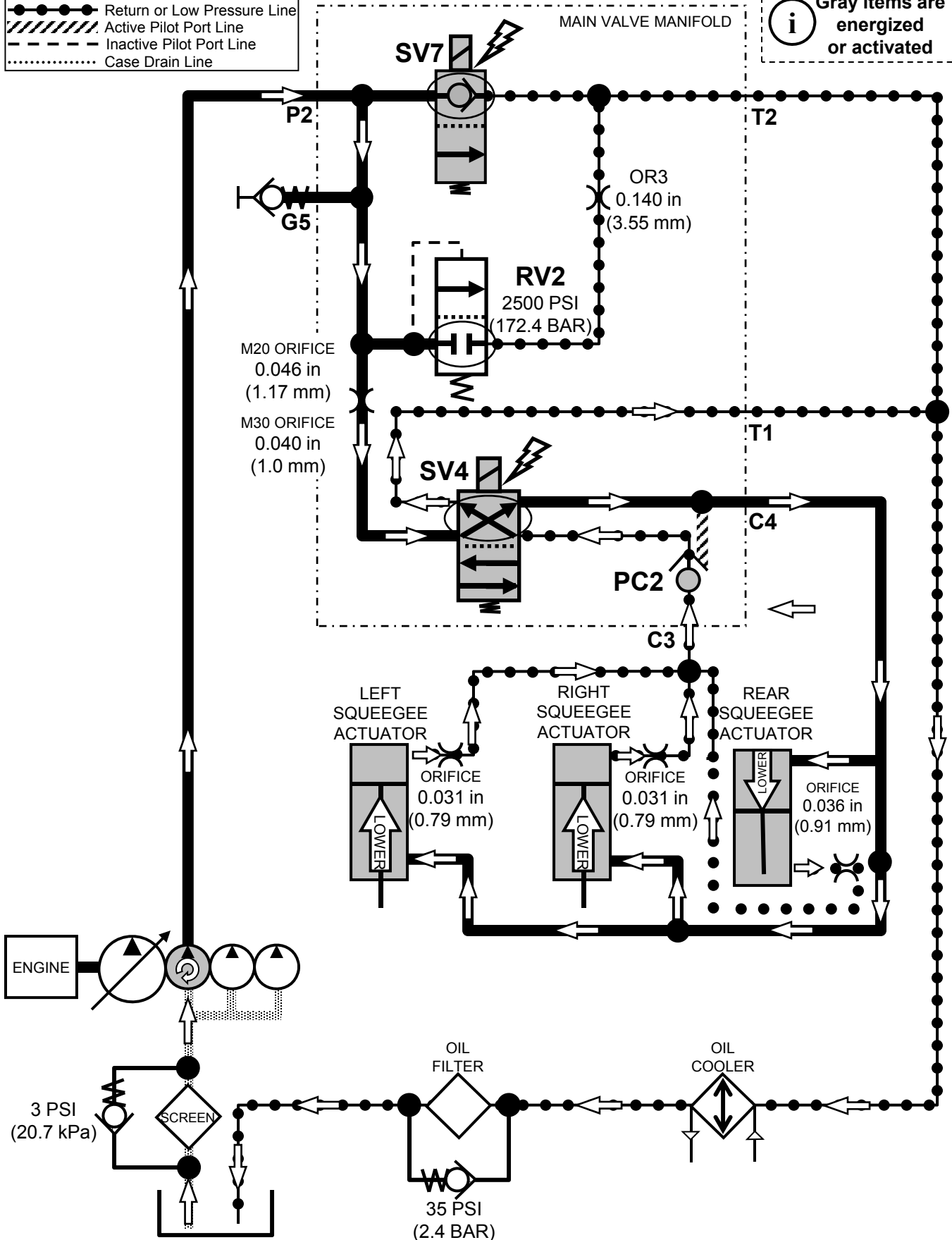

M20_M30 Squeegee Lift

Engine speed: High

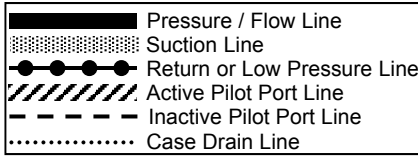

i Gray items are energized or activated

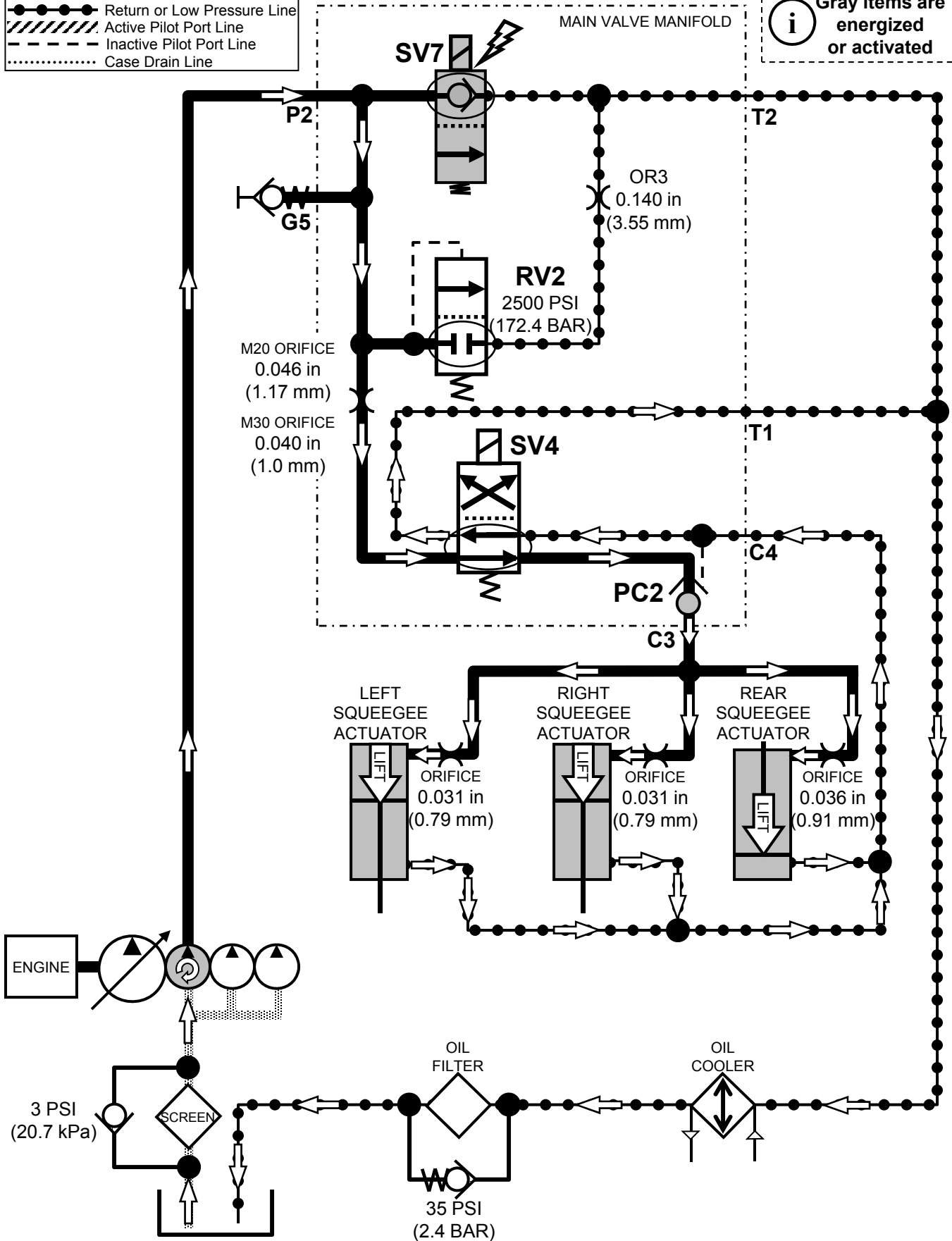

M20_M30 Main Brushes On

Engine speed: High

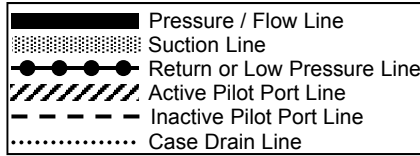

i Gray items are energized or activated

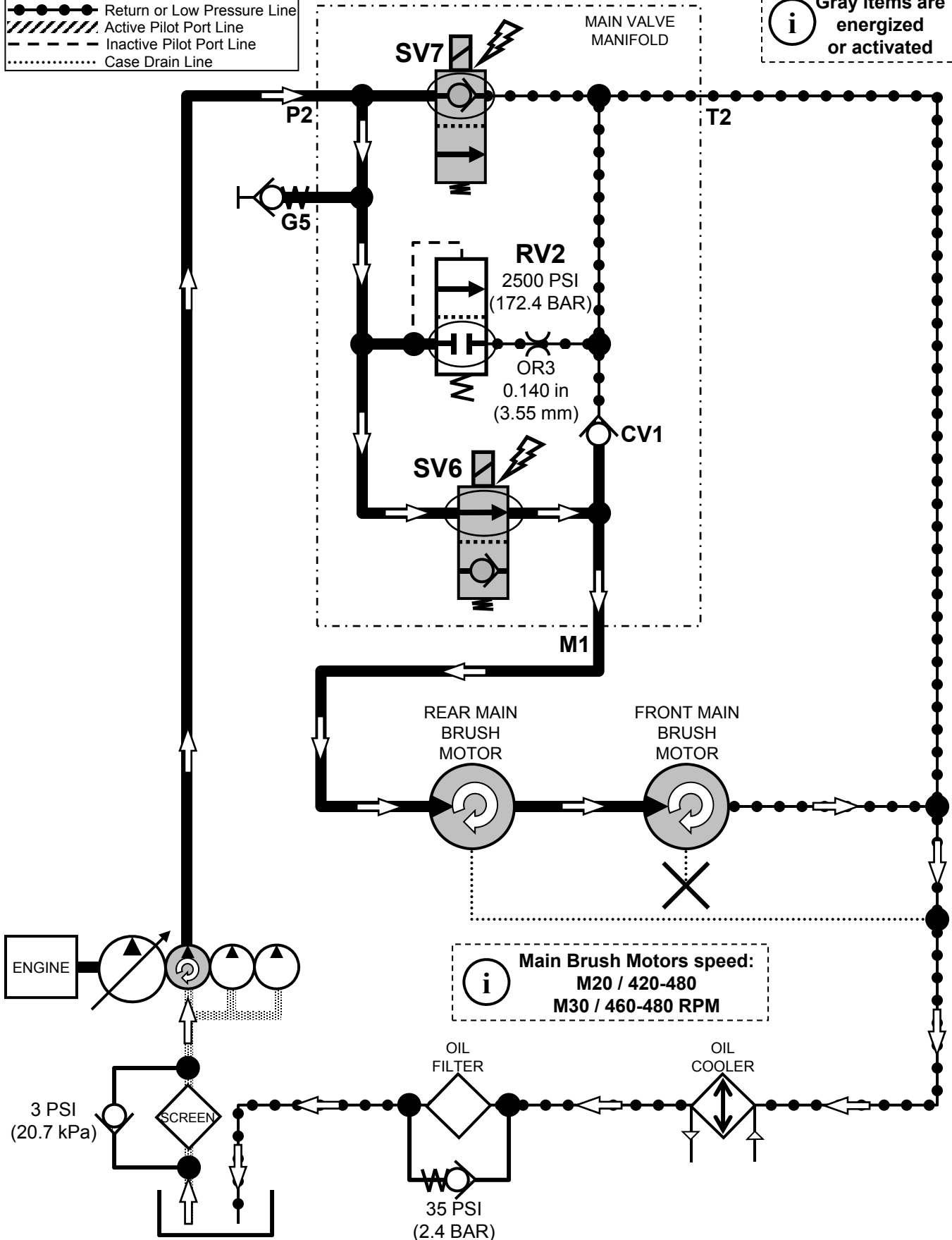

M20_M30 Side Brush On

Engine speed: High

i Gray items are energized or activated

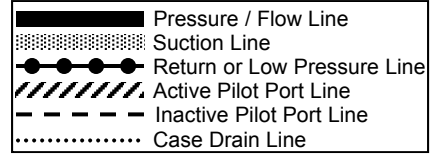

i Side Brush can only be operated when Main Brushes are ON

i Side Brush Motor speed: 140-160 RPM

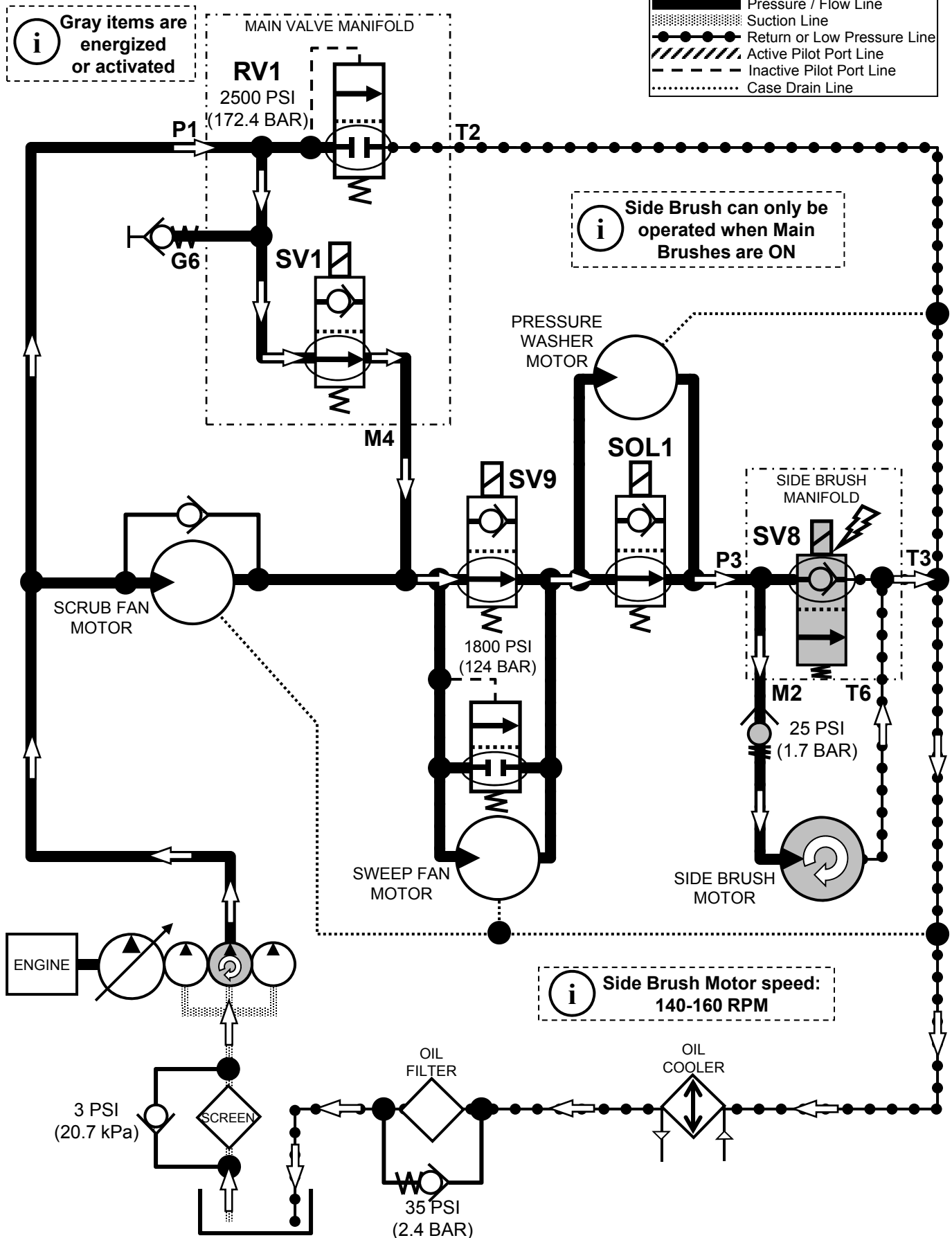

M20_M30 Scrub Vacuum Fan On

Engine speed: High

i Gray items are energized or activated

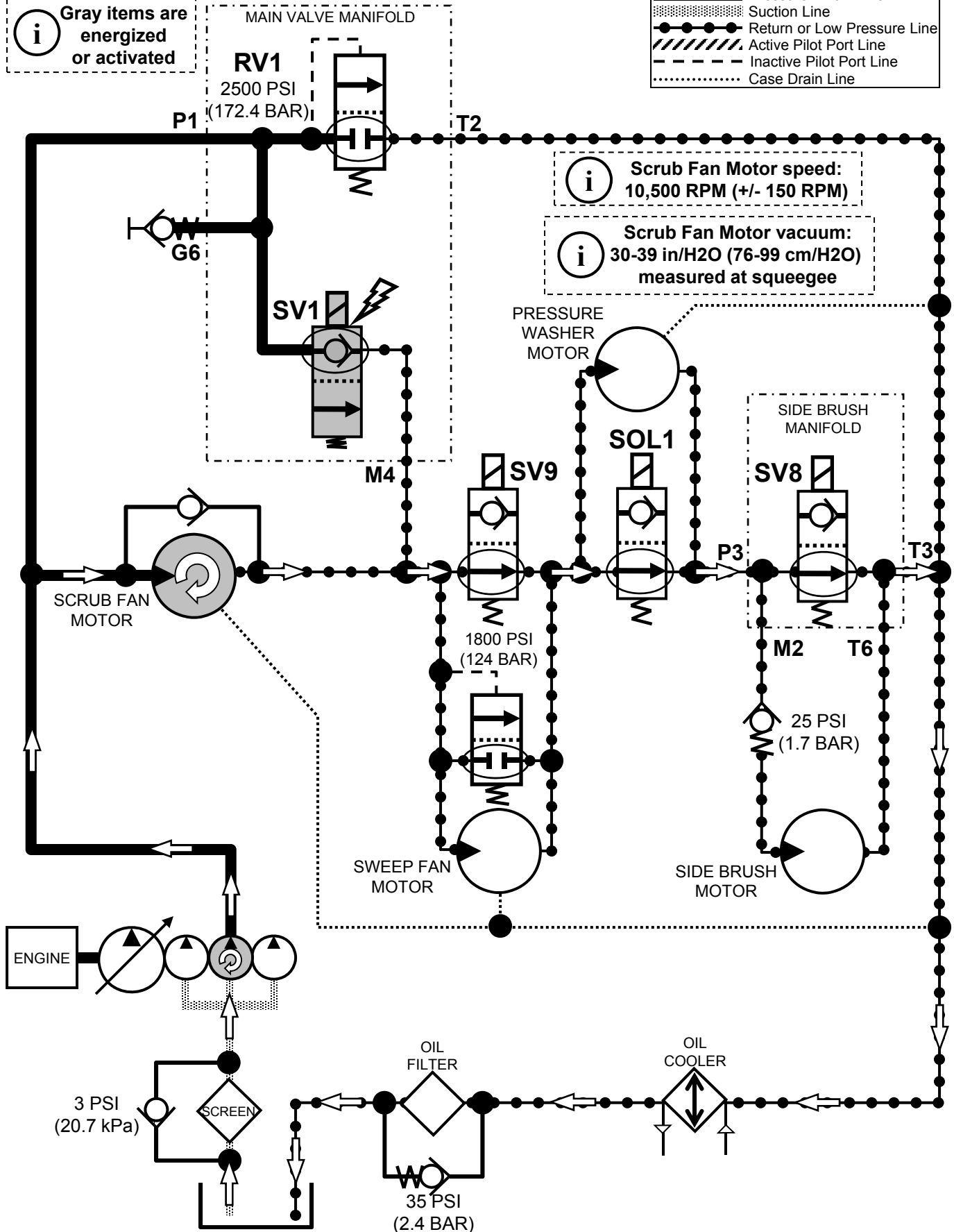
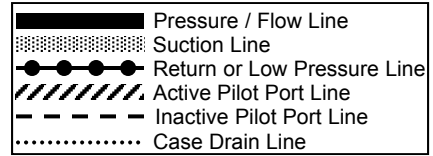

M20_M30 Scrub Vacuum Fan & Side Brush On

Engine speed: High

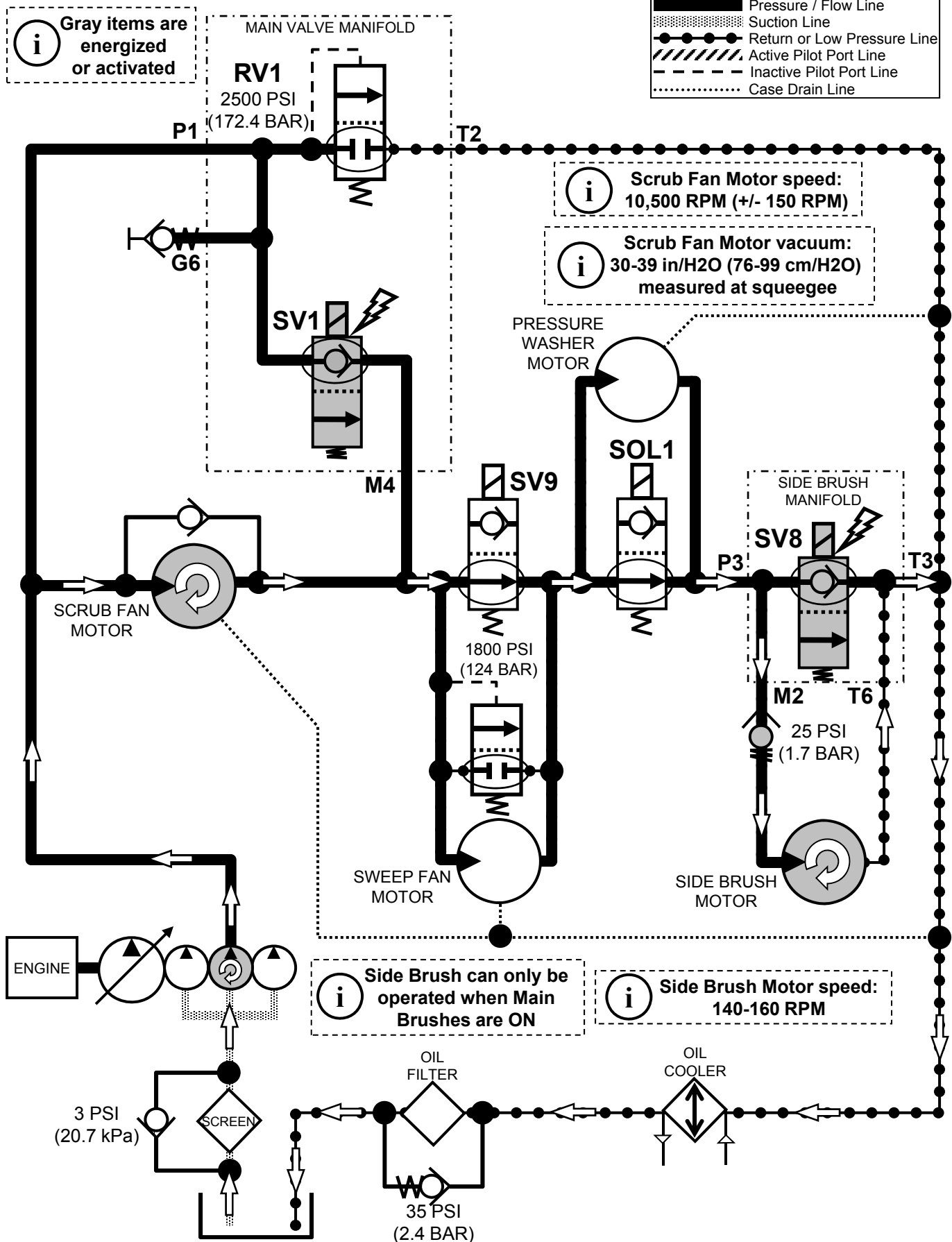

M20_M30 Scrub Vacuum Fan On

Engine speed: High

i Gray items are energized or activated

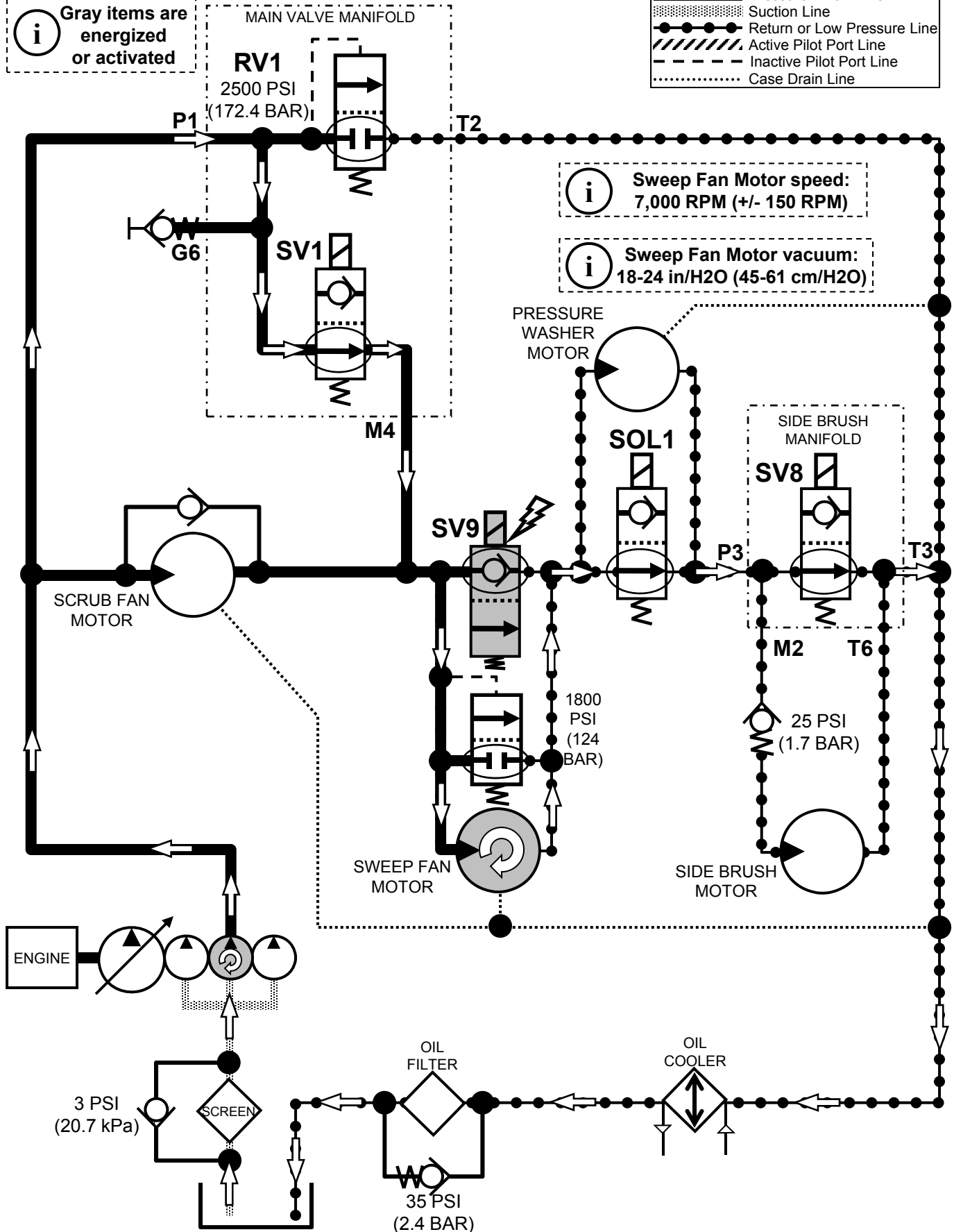
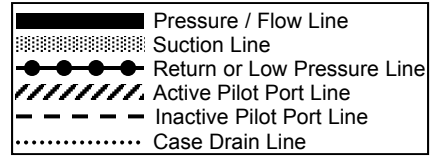

M20_M30 Scrub Vacuum Fan & Side Brush On

Engine speed: High

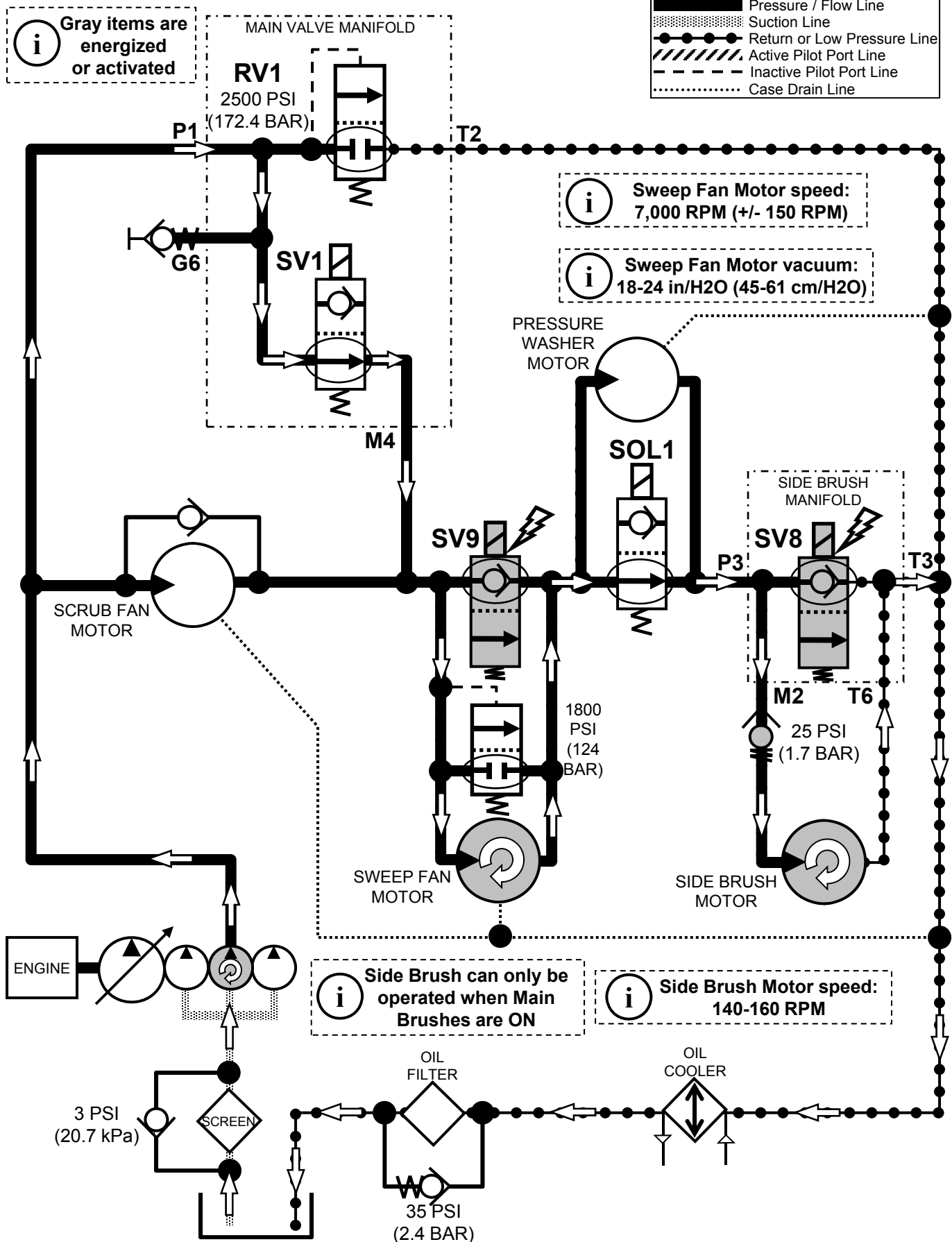

M20_M30 Pressure Washer On

Engine speed: High

i Gray items are energized or activated

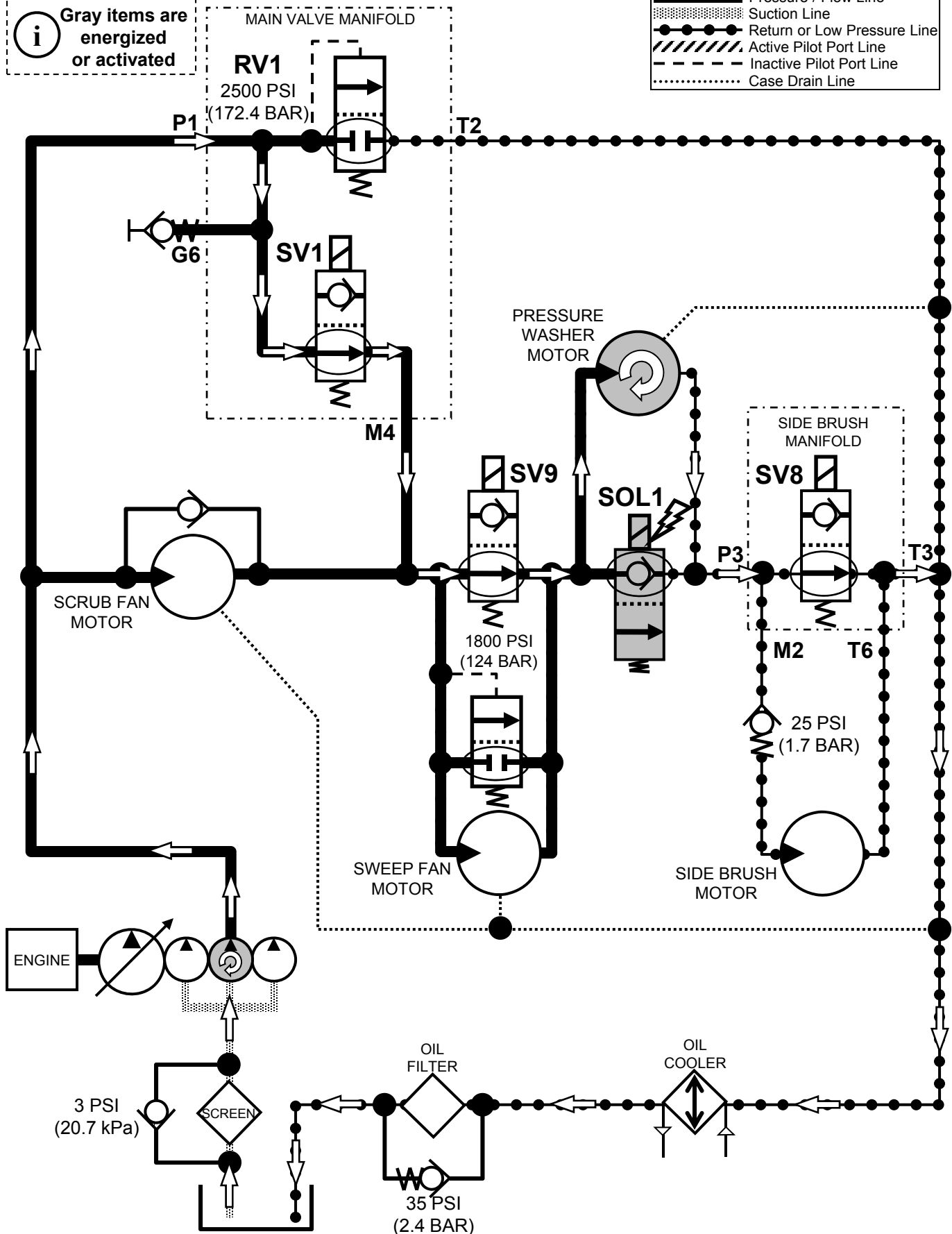
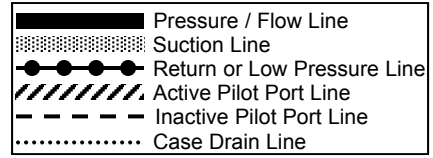

M20_M30 Hopper Lift

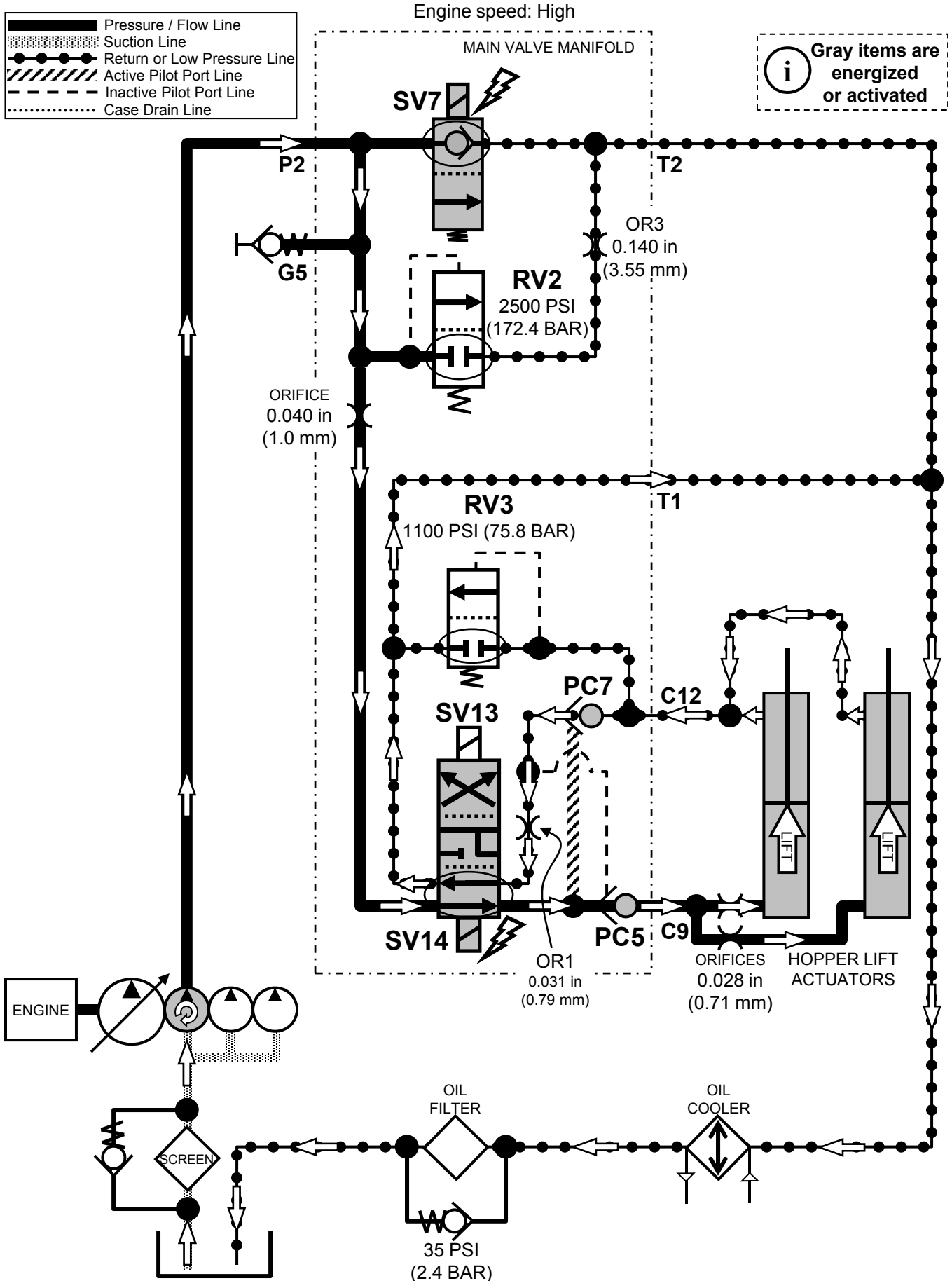

M20_M30 Hopper Lower

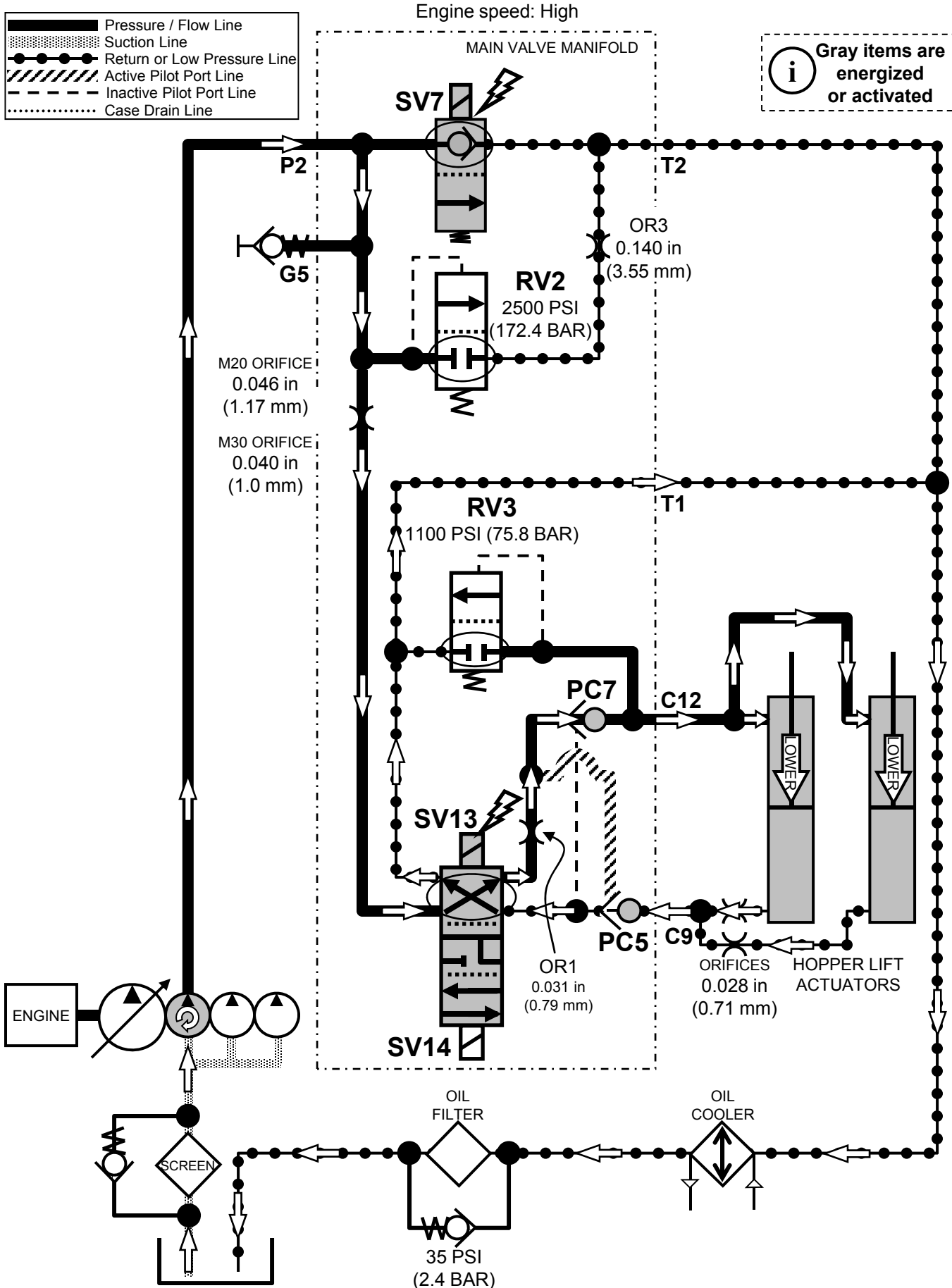

M20_M30 Hopper Door Open

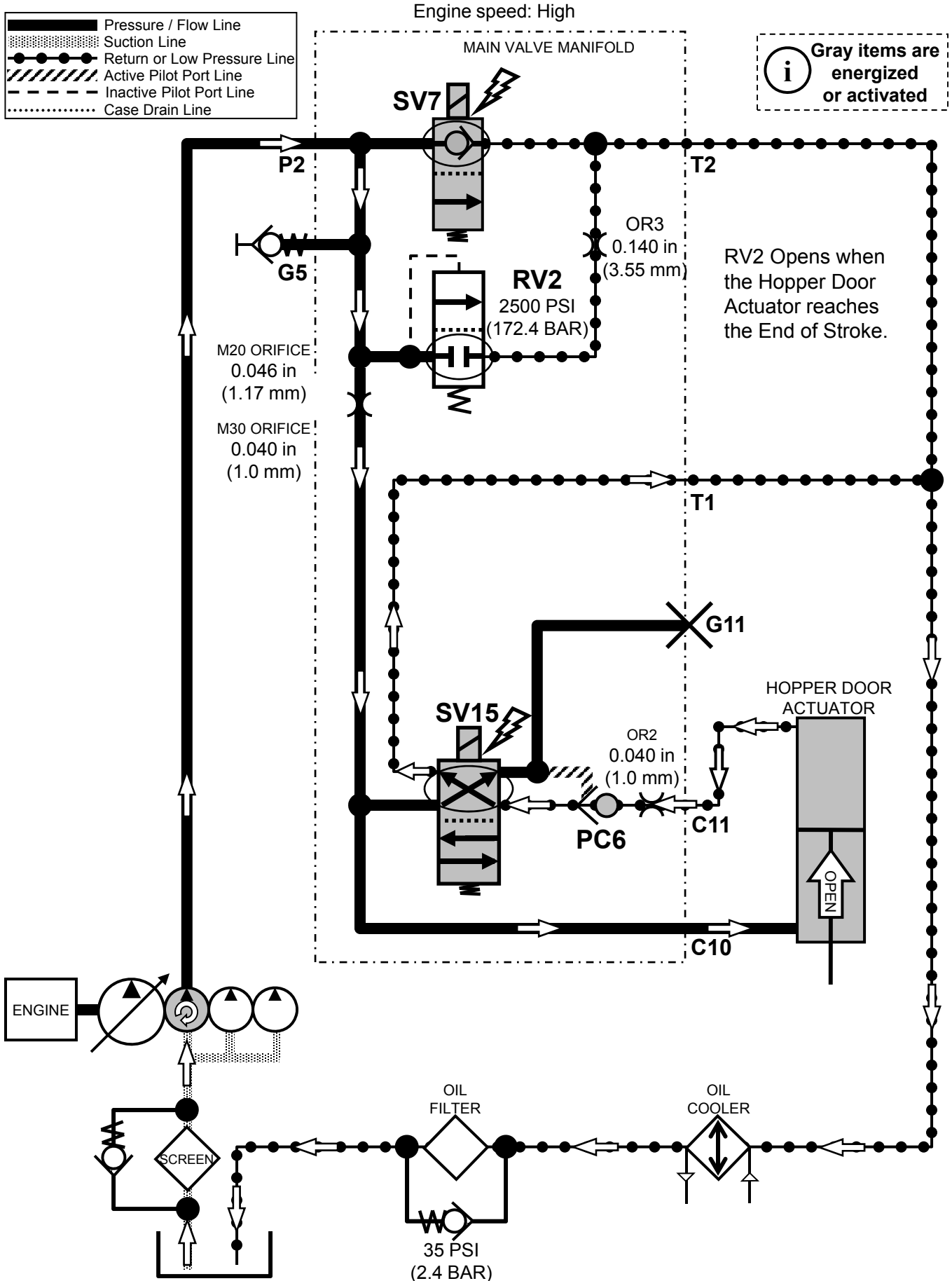

M20_M30 Hopper Door Close

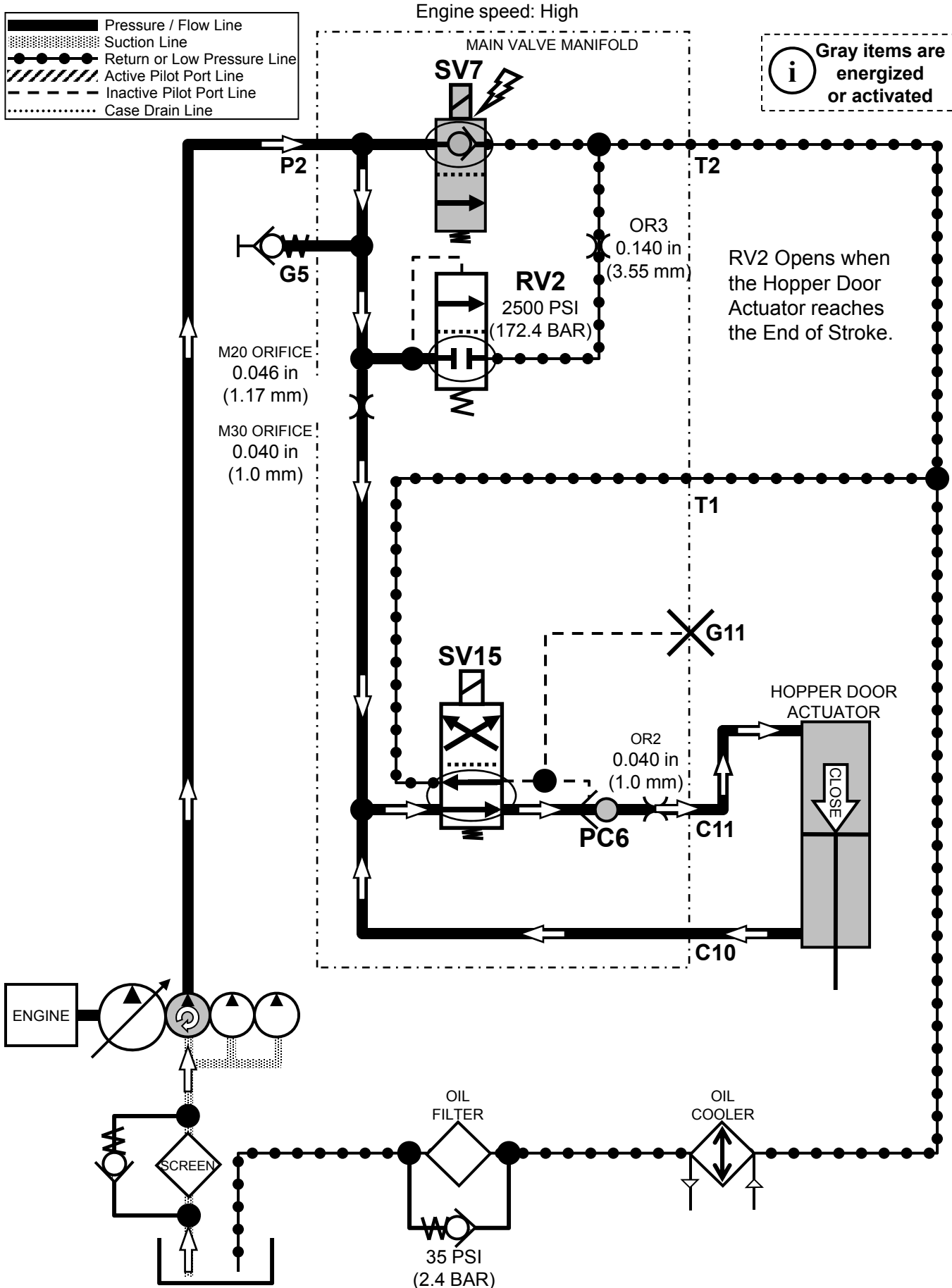

M20_M30 Side Brush Lower

Engine speed: High

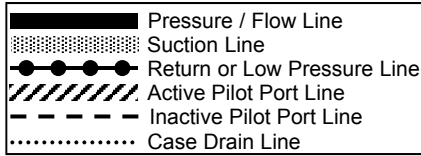

RV2 Opens when the Side Brush Lift Actuator reaches the End of Stroke.

Default M20 SCRUBBING Pressure Readings

# Brush LEDs ON	Pressure at G1
1	95 - 143 psi (6.5 - 9.8 bar)
2	160 - 240 psi (11 - 16.5 bar)
3	280 - 400 psi (19.3 - 27.5 bar)

Default M20 SWEEPING Pressure Readings

# Brush LEDs ON	Pressure at G1
1	6 - 14 psi (0.4 - 1 bar)
2	38 - 56 psi (2.6 - 3.8 bar)
3	73 - 109 psi (5 - 7.5 bar)

Default M30 SCRUBBING Pressure Readings

# Brush LEDs ON	Pressure at G13
1	320 - 370 psi (22 - 25.5 bar)
2	410 - 450 psi (28.3 - 31 bar)
3	510 - 560 psi (35.1 - 38.6 bar)

Default M30 SWEEPING Pressure Readings

# Brush LEDs ON	Pressure at G13
1	275 - 340 psi (18.9 - 23.4 bar)
2	310 - 370 psi (21.3 - 25.5 bar)
3	400 - 480 psi (27.5 - 33 bar)

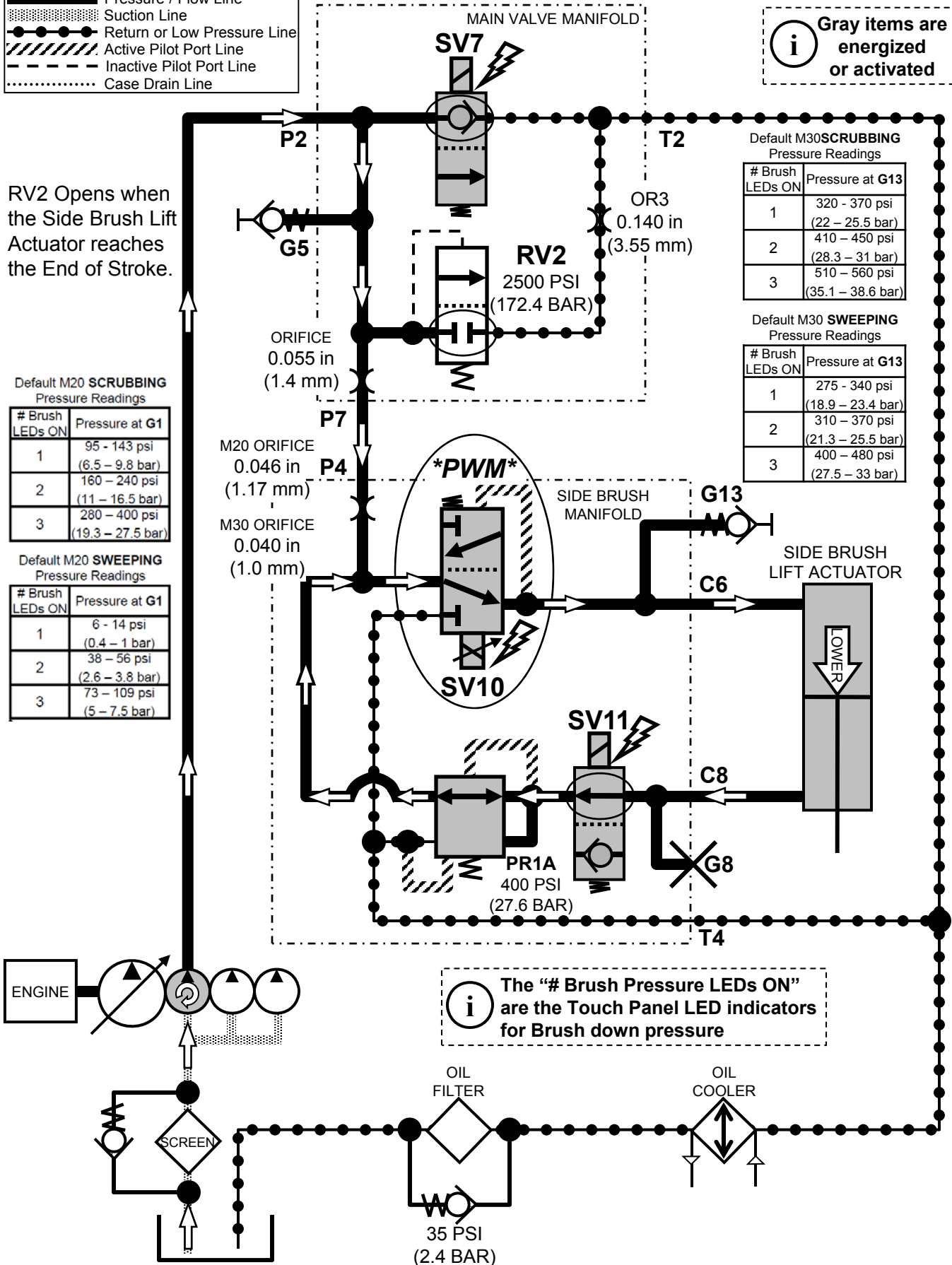

The "# Brush Pressure LEDs ON" are the Touch Panel LED indicators for Brush down pressure

M20_M30 Side Brush Lift

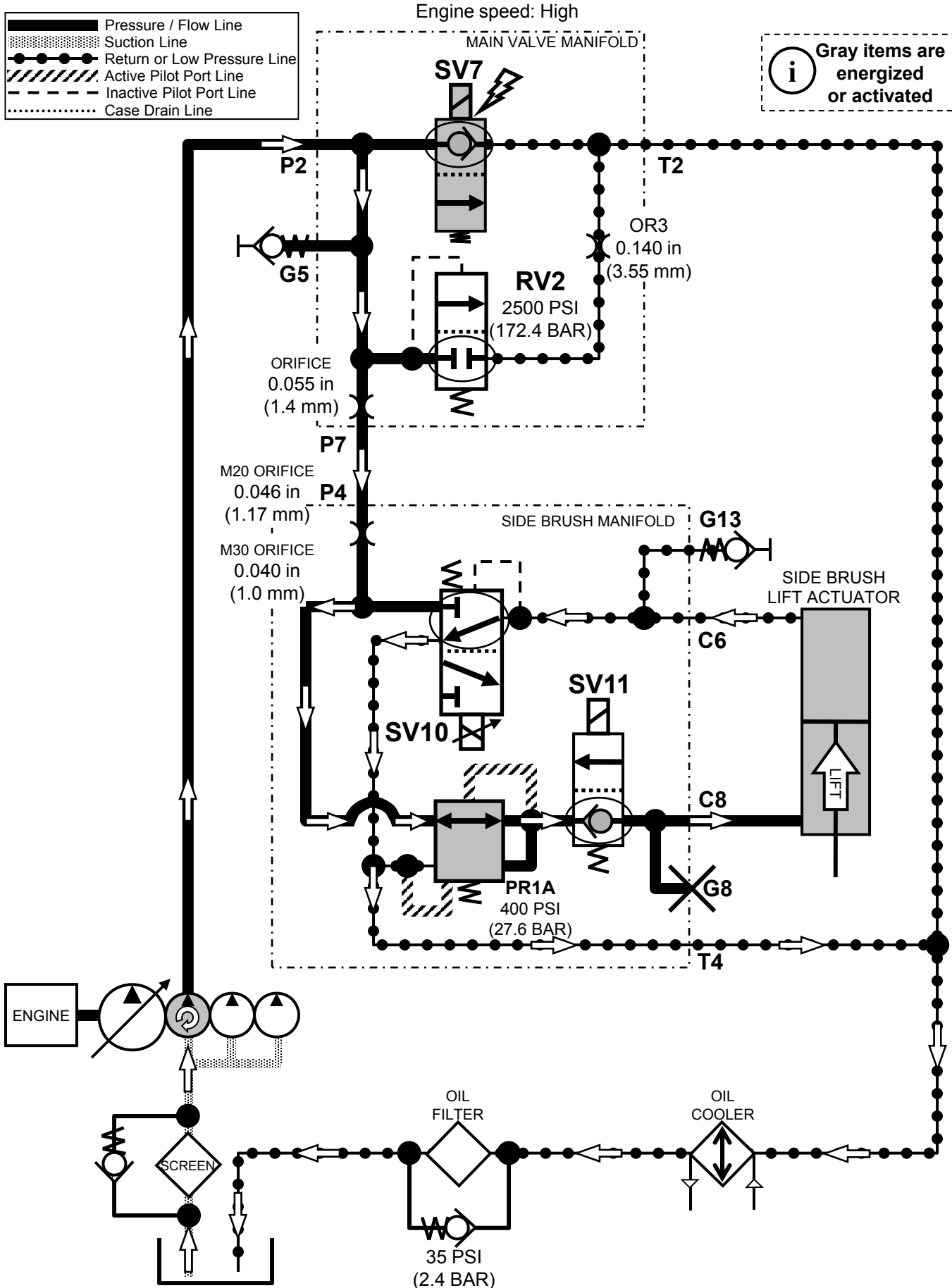

M20_M30 Side Brush Extend

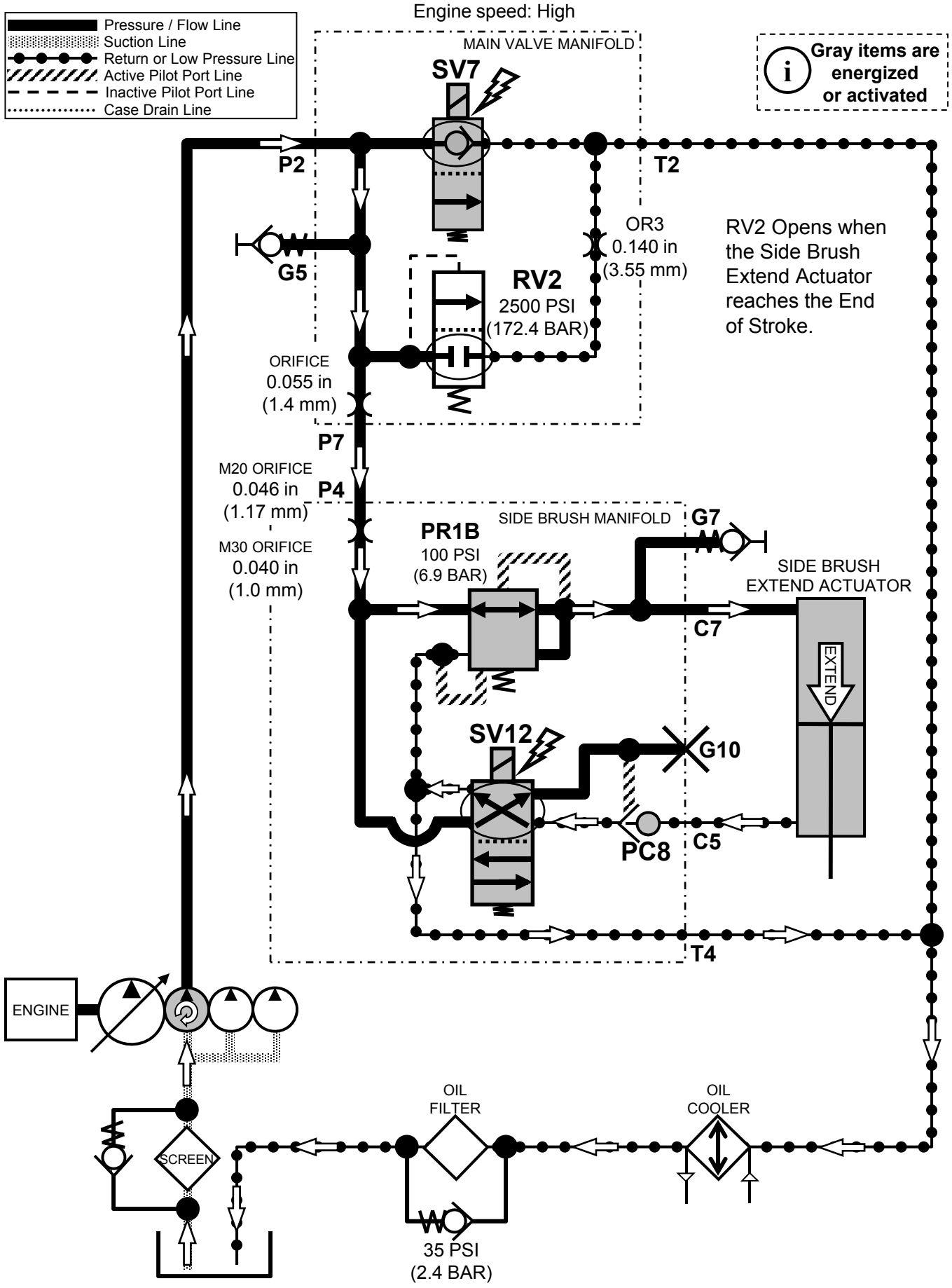

M20_M30 Side Brush Retract

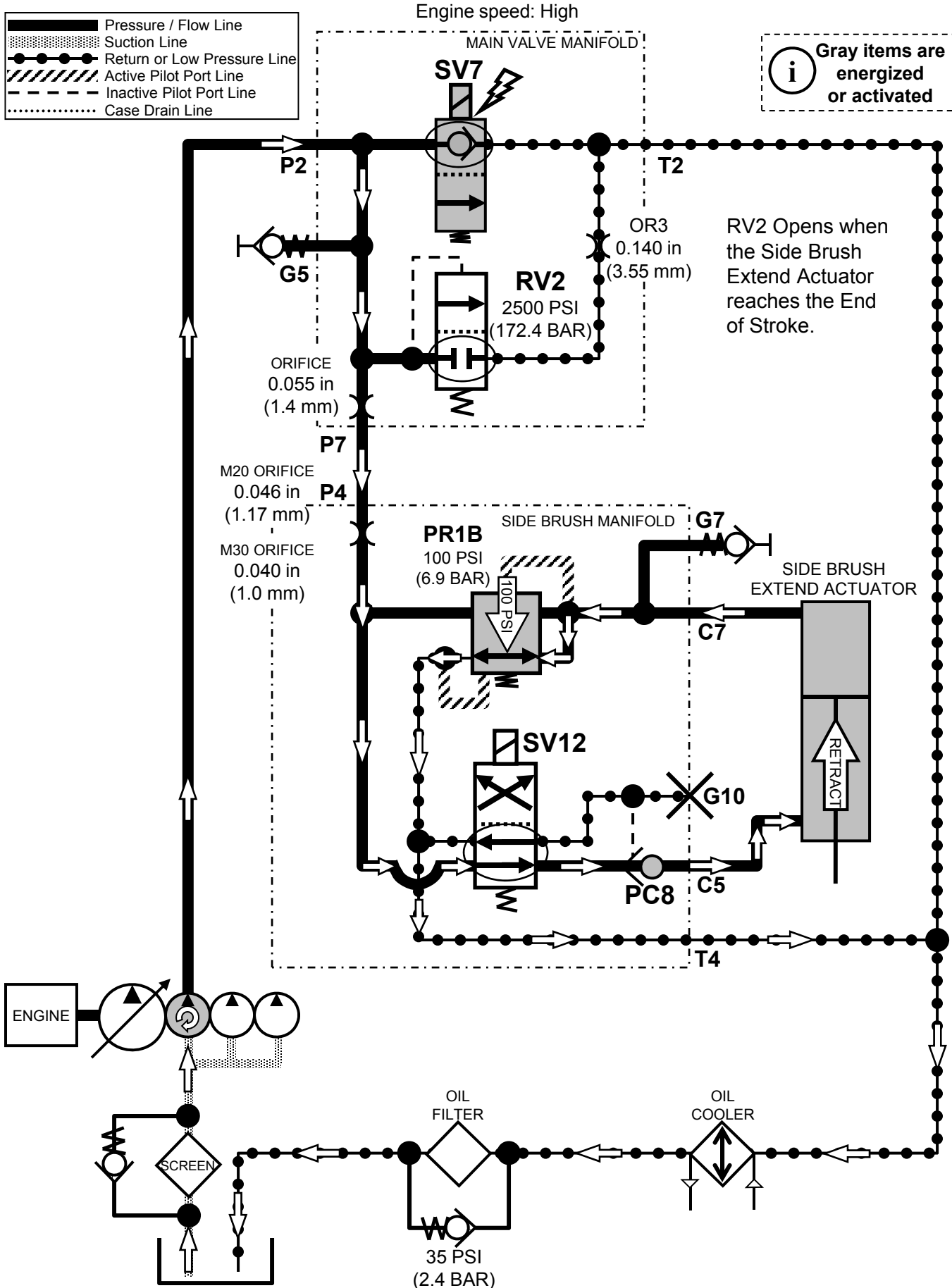

Hydraulic Solenoid Valve Details

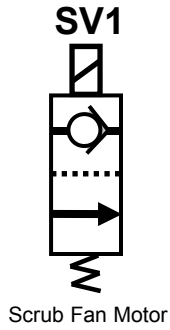

Scrub Fan Motor

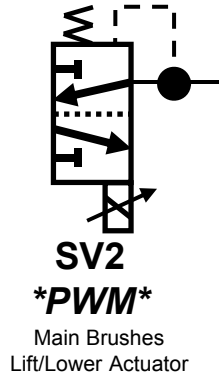

Main Brushes
Lift/Lower Actuator

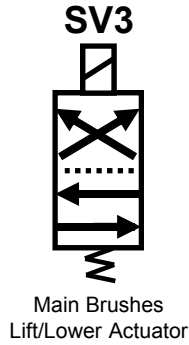

Main Brushes
Lift/Lower Actuator

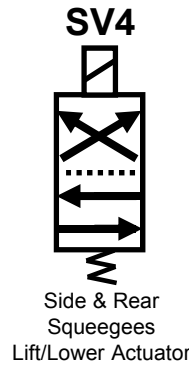

Side & Rear
Squeegees
Lift/Lower Actuator

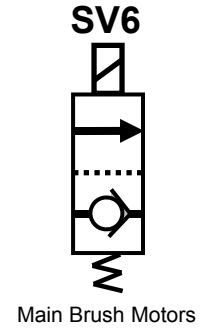

Main Brush Motors

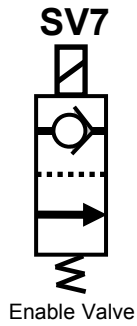

Enable Valve

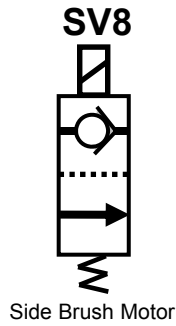

Side Brush Motor

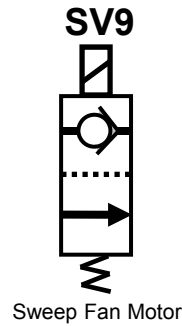

Sweep Fan Motor

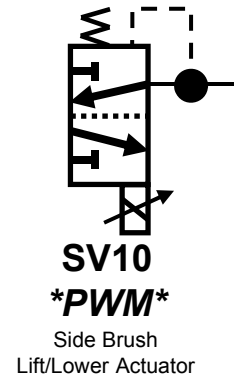

Side Brush
Lift/Lower Actuator

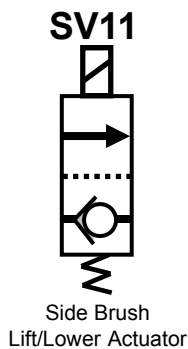

Side Brush
Lift/Lower Actuator

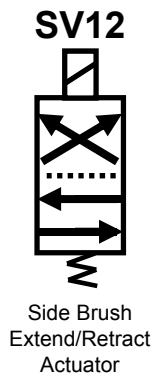

Side Brush
Extend/Retract
Actuator

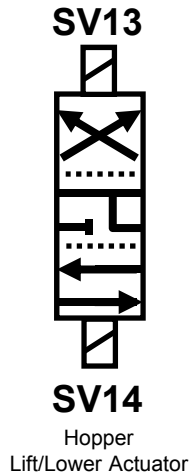

Hopper
Lift/Lower Actuator

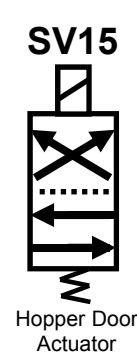

Hopper Door
Actuator

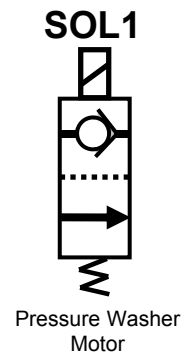

Pressure Washer
Motor

M20_M30 Fault Codes (ProPanel and Standard Panel)

Fault Code Number	Fault Name	Fault Code (ProPanel)	Fault Code (Standard)
0x0010	FAULT_PARKING_BRAKE	Parking Brake	Park Brake
0x0101	FAULT_MOTOR1_OPEN	Main On Valve Electrical Open Fault	M ONVlv Opn
0x0106	FAULT_MOTOR1_SHORT	Main On Valve Electrical Short Fault	M ONVlv Srt
0x0107	FAULT_MOTOR1_FET_SHORT	Main On Valve FET Fault	M ONVlv FET
0x0121	FAULT_MOTOR3_OPEN	Side On Valve Electrical Open Fault	S ONVlv Opn
0x0126	FAULT_MOTOR3_SHORT	Side On Valve Electrical Short Fault	S ONVlv Srt
0x0127	FAULT_MOTOR3_FET_SHORT	Side On Valve FET Fault	S ONVlv FET
0x0171	FAULT_MOTOR8_OPEN	Filter Shaker Motor Electrical Open Alert	Shaker Opn
0x0176	FAULT_MOTOR8_SHORT	Filter Shaker Motor Electrical Short Fault	Shaker Srt
0x0177	FAULT_MOTOR8_FET_SHORT	Filter Shaker Motor FET Fault	Shaker FET
0x0201	FAULT_ACTUATOR1_OPEN	Main Brush Down Valve Electrical Open Alert	M DnVlv Opn
0x0211	FAULT_ACTUATOR2_OPEN	Squeegee Valve Electrical Open Alert	Sqg Opn
0x0221	FAULT_ACTUATOR3_OPEN	Side Broom Down Valve Electrical Open Alert	S DnVlv Opn
0x0226	FAULT_ACTUATOR3_SHORT	Side Broom Down Valve Electrical Short Fault	S DnVlv Srt
0x0227	FAULT_ACTUATOR3_FET_SHORT	Side Broom Down Valve FET Fault	S DnVlv FET
0x0231	FAULT_ACTUATOR4_OPEN	Side Broom Extend Electrical Open Alert	S ExVlv Opn
0x0236	FAULT_ACTUATOR4_SHORT	Side Broom Extend Electrical Short Fault	S ExVlv Srt

**M20_M30 Fault Codes
(ProPanel and Standard Panel)**

Fault Code Number	Fault Name	Fault Code (ProPanel)	Fault Code (Standard)
0x0237	FAULT_ACTUATOR4_FET_SHORT	Side Broom Extend FET Fault	S ExVlv FET
0x0251	FAULT_ACTUATOR6_OPEN	Hopper Lower Valve Electrical Open Alert	HpLwVlv Opn
0x0256	FAULT_ACTUATOR6_SHORT	Hopper Lower Valve Electrical Short Fault	HpLwVlv Srt
0x0257	FAULT_ACTUATOR6_FET_SHORT	Hopper Lower Valve FET Fault	HpLwVlv FET
0x0261	FAULT_ACTUATOR7_OPEN	Hopper Raise Valve Electrical Open Alert	HpRsVlv Opn
0x0266	FAULT_ACTUATOR7_SHORT	Hopper Raise Valve Electrical Short Fault	HpRsVlv Srt
0x0267	FAULT_ACTUATOR7_FET_SHORT	Hopper Raise Valve FET Fault	HpRsVlv FET
0x0271	FAULT_ACTUATOR8_OPEN	Hopper Door Electrical Open Alert	HpDoor Opn
0x0276	FAULT_ACTUATOR8_SHORT	Hopper Door Electrical Short Fault	HpDoor Srt
0x0277	FAULT_ACTUATOR8_FET_SHORT	Hopper Door FET Fault	HpDoor FET
0x0301	FAULT_VALVE1_OPEN	Main Water Valve Electrical Open Alert	M Water Opn
0x0306	FAULT_VALVE1_SHORT	Main Water Valve Electrical Short Fault	M Water Srt
0x0307	FAULT_VALVE1_FET_SHORT	Main Water Valve FET Fault	M Water FET
0x0311	FAULT_VALVE2_OPEN	Horn Electrical Open Alert	Horn Opn
0x0316	FAULT_VALVE2_SHORT	Horn Electrical Short Fault	Horn Srt
0x0317	FAULT_VALVE2_FET_SHORT	Horn FET Fault	Horn FET

M20_M30 Fault Codes
(ProPanel and Standard Panel)

Fault Code Number	Fault Name	Fault Code (ProPanel)	Fault Code (Standard)
0x0321	FAULT_VALVE3_OPEN	Alarm Electrical Open Alert	Alarm Opn
0x0326	FAULT_VALVE3_SHORT	Alarm Electrical Short Fault	Alarm Srt
0x0327	FAULT_VALVE3_FET_SHORT	Alarm FET Fault	Alarm FET
0x0331	FAULT_VALVE4_OPEN	Side Scrub Valve Electrical Open Alert	S Water Opn
0x0336	FAULT_VALVE4_SHORT	Side Scrub Valve Electrical Short Fault	S Water Srt
0x0337	FAULT_VALVE4_FET_SHORT	Side Scrub Valve FET Fault	S Water FET
0x0341	FAULT_VALVE5_OPEN	Solution Auto-Fill Valve Electrical Open Alert	SAF Vlv Opn
0x0346	FAULT_VALVE5_SHORT	Solution Auto-Fill Valve Electrical Short Fault	SAF Vlv Srt
0x0347	FAULT_VALVE5_FET_SHORT	Solution Auto-Fill Valve FET Fault	SAF Vlv FET
0x0351	FAULT_VALVE6_OPEN	Recovery Auto-Fill Valve Electrical Open Alert	RAF Vlv Opn
0x0356	FAULT_VALVE6_SHORT	Recovery Auto-Fill Valve Electrical Short Fault	RAF Vlv Srt
0x0357	FAULT_VALVE6_FET_SHORT	Recovery Auto-Fill Valve FET Fault	RAF Vlv FET
0x0361	FAULT_VALVE7_OPEN	Enable Valve Electrical Open Alert	Enable Opn
0x0366	FAULT_VALVE7_SHORT	Enable Valve Electrical Short Fault	Enable Srt
0x0367	FAULT_VALVE7_FET_SHORT	Enable Valve FET Fault	Enable FET
0x0371	FAULT_VALVE8_OPEN	Hopper Latch Electrical Open Alert	HpLatch Opn
0x0376	FAULT_VALVE8_SHORT	Hopper Latch Electrical Short Fault	HpLatch Srt

**M20_M30 Fault Codes
(ProPanel and Standard Panel)**

Fault Code Number	Fault Name	Fault Code (ProPanel)	Fault Code (Standard)
0x0377	FAULT_VALVE8_FET_SHORT	Hopper Latch FET Fault	HpLatch FET
0x0381	FAULT_VALVE9_OPEN	High Flow Valve Electrical Open Alert	HiFlow Opn
0x0386	FAULT_VALVE9_SHORT	High Flow Valve Electrical Short Fault	HiFlow Srt
0x0387	FAULT_VALVE9_FET_SHORT	High Flow Valve FET Fault	HiFlow FET
0x0391	FAULT_VALVE10_OPEN	FaST Side Pump Electrical Open Alert	FASTSde Opn
0x0396	FAULT_VALVE10_SHORT	FaST Side Pump Electrical Short Fault	FASTSde Srt
0x0397	FAULT_VALVE10_FET_SHORT	FaST Side Pump FET Fault	FASTSde FET
0x0401	FAULT_RELAY1_OPEN	Reverse Relay Open Alert	Reverse Opn
0x0406	FAULT_RELAY1_SHORT	Reverse Relay Electrical Short Fault	Reverse Srt
0x0407	FAULT_RELAY1_FET_SHORT	Reverse Relay FET Fault	Reverse FET
0x0411	FAULT_RELAY2_OPEN	Shut Down Relay Open Alert	ShutDn Opn
0x0416	FAULT_RELAY2_SHORT	Shut Down Relay Eletrical Short Fault	ShutDn Srt
0x0417	FAULT_RELAY2_FET_SHORT	Shut Down Relay FET Fault	ShutDn FET
0x0501	FAULT_VACUUM1_OPEN	Pickup Vac Electrical Open Alert	PkUpVac Opn
0x0506	FAULT_VACUUM1_SHORT	Pickup Vac Electrical Short Fault	PkUpVac Srt
0x0507	FAULT_VACUUM1_FET_SHORT	Pickup Vac FET Fault	PkUpVac FET
0x0521	FAULT_VACUUM3_OPEN	Dust Vac Electrical Open Alert	DustVac Opn

M20_M30 Fault Codes
(ProPanel and Standard Panel)

Fault Code Number	Fault Name	Fault Code (ProPanel)	Fault Code (Standard)
0x0526	FAULT_VACUUM3_SHORT	Dust Vac Electrical Short Fault	DustVac Srt
0x0527	FAULT_VACUUM3_FET_SHORT	Dust Vac FET Short	DustVac FET
0x0611	FAULT_PUMP2_OPEN	Detergent Pump Electrical	DetPump Opn
0x0616	FAULT_PUMP2_SHORT	Detergent Pump Electrical Short Fault	DetPump Srt
0x0617	FAULT_PUMP2_FET_SHORT	Detergent Pump FET Fault	DetPump FET
0x0621	FAULT_PUMP3_OPEN	Extended Scrub Pump	ES Pump Opn
0x0626	FAULT_PUMP3_SHORT	Extended Scrub Pump Electrical Short Fault	ES Pump Srt
0x0627	FAULT_PUMP3_FET_SHORT	Extended Scrub Pump FET Fault	ES Pump FET
0x0636	FAULT_PUMP4_FET_SHORT	FAST Pump FET Fault	FASTPumpFET
0x0637	FAULT_PUMP4_SHORT	FAST Pump Electrical Short Fault	FASTPumpSrt
0x0631	FAULT_PUMP4_OPEN	FAST Pump Electrical Open	FASTPumpOpn
0x0700	FAULT_ECH20_GENERIC	EC-H2O Module Fault	Ec Module
0x0701	FAULT_ECH20_FLUSH_NEEDED	EC-H2O System Flush Needed	Ec Flsh Flt
0x0705	FAULT_ECH20_SYSTEM	EC-H2O System Fault	Ec System
0x0711	FAULT_ECH20_PUMP_OPEN	EC-H2O Pump Electrical Open Fault	Ec Pump Opn
0x0716	FAULT_ECH20_PUMP_SHORT	EC-H2O Pump Electrical Short Fault	Ec Pump Srt
0x0717	FAULT_ECH20_PUMP_FET_SHORT	EC-H2O Pump FET Fault	Ec Pump FET
0x0761	FAULT_ECH20_SIDE_VALVE_OPEN	EC-H2O Side Valve Electrical Open Alert	Ec Sde Opn

**M20_M30 Fault Codes
(ProPanel and Standard Panel)**

Fault Code Number	Fault Name	Fault Code (ProPanel)	Fault Code (Standard)
0x0766	FAULT_ECH20_SIDE_VALVE_SHORT	EC-H20 Side Valve Electrical Electrical Short Fault	Ec Sde Srt
0x0767	FAULT_ECH20_SIDE_VALVE_FET_SHORT	EC-H20 Side Valve Electrical FET Fault	Ec Sde FET
0x0790	FAULT_SOLUTION_TANK_EMPTY	Solution Tank Empty	SolTnkEmpty
0x0791	FAULT_RECOVERY_TANK_FULL	Recovery Tank Full	RcvTnk Full
0x07A0	FAULT_FILTER_CLOGGED	Clogged Filter Warning	Clog Filter
0x07A1	FAULT_HOPPER_FIRE	Hopper on Fire	Hopper Fire
0x07A2	FAULT_HOPPER_NOT_HOME	Hopper not in Home position	Hopper Up
0x07A3	FAULT_SHAKER_CLOGGED	Clogged Shaker Warning	Clog Shaker
0x07A4	FAULT_SEAT_EMPTY	Seat Empty	Seat Empty
0x07B0	FAULT_ENGINE_HIGH_TEMP	High Engine Temp Warning	Hi Egn Temp
0x07B1	FAULT_HYDRAULIC_HIGH_TEMP	High Hydraulic Temp Warning	Hi Hyd Temp
0x07B2	FAULT_ENGINE_MALFUNCTION_INDICATOR	Engine Malfunction Indicator	MIL Fault
0x07B3	FAULT_LOW_FUEL	Low Fuel	Low Fuel
0x07B4	FAULT_ENGINE_LOW_OIL_PRESSURE	Engine Low Oil Pressure Warning	Low Oil Psr
0x07B5	FAULT_ENGINE_ALTERNATOR_LOW_VOLTAGE	Engine Alternator Low Voltage Warning	Alt LowVolt
0x0A01	FAULT_PWM_VALVE1_OPEN	Main Brush Down Pressure Open Alert	M DnPsr Opn
0x0A06	FAULT_PWM_VALVE1_SHORT	Main Brush Down Pressure Electrical Short Fault	M DnPsr Srt

M20_M30 Fault Codes
(ProPanel and Standard Panel)

Fault Code Number	Fault Name	Fault Code (ProPanel)	Fault Code (Standard)
0x0A07	FAULT_PWM_VALVE1_FET_SHORT	Main Brush Down Pressure FET Fault	M DnPsr FET
0x0A11	FAULT_PWM_VALVE2_OPEN	Side Brush Down Pressure Open Alert	S DnPsr Opn
0x0A16	FAULT_PWM_VALVE2_SHORT	Side Brush Down Pressure Electrical Short Fault	S DnPsr Srt
0x0A17	FAULT_PWM_VALVE2_FET_SHORT	Side Brush Down Pressure FET Fault	S DnPsr FET
0x2000	FAULT_PASCAL_GENERAL	Touch screen Error	Pascal Flt
0xFF20	FAULT_CAN_COMMUNICATION_O FFLINE	Scrub Module A CAN Communication Fault	Scrub A CAN
0xFF21	FAULT_CAN_COMMUNICATION_O FFLINE2	Scrub Module B CAN Communication Fault	Scrub B CAN
0xFF22	FAULT_CAN_COMMUNICATION_O FFLINE3	Telemetry CAN Communication Fault	Tele CAN

M Series Maintenance

MAINTENANCE

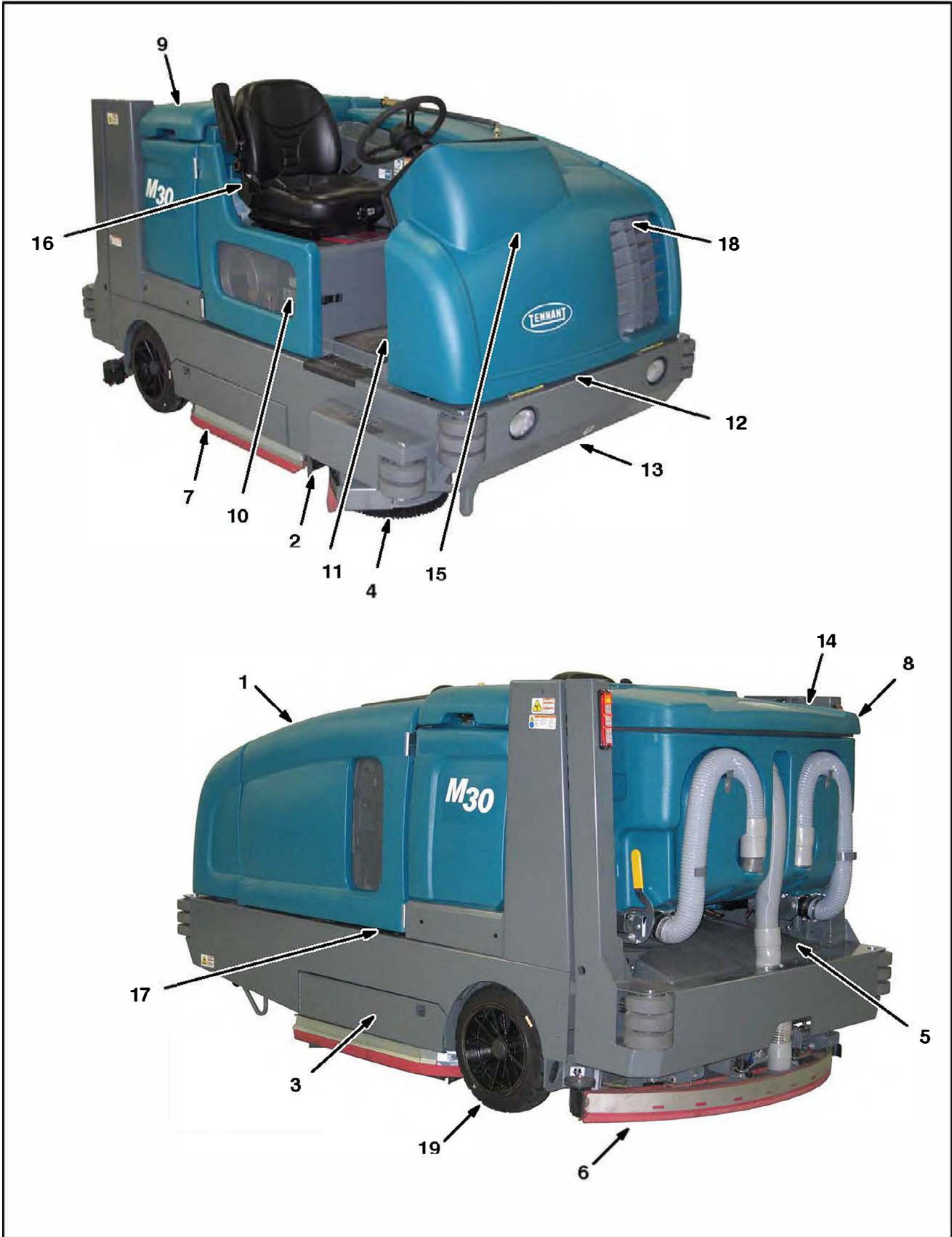

O = Operator.

T = Trained Service Mechanic.

Interval	Person Resp.	Key	Description	Procedure	Lubricant /Fluid	No. of Service Points
100 Hours	T	18	Radiator	Clean core exterior	-	1
	T	18	Hydraulic cooler	Clean core exterior	-	1
	T	1	Engine	Change oil and filter	EO	1
				Drain LPG vaporizer oil buildup	-	1
	O	13, 19	Tires	Check for damage	-	3
	T	6	Rear squeegee casters	Lubricate	SPL	2
	T	6	Rear squeegee	Check leveling	-	1
	O	2	Scrub head skirt	Check for damage or wear	-	1
200 Hours	T	12	Front wheel support bearings	Lubricate	SPL	2
	T	1, 17	Torque tube	Lubricate	SPL	4
	T	12	Steering cylinder	Lubricate	SPL	1
	T	1, 18	Radiator hoses and clamps	Check for tightness and wear	-	2
	T	11	Brake pedal	Check adjustment	-	1
	T	14	Hopper lift arm pivots	Lubricate	SPL	2
	T	5	Hopper door pivots	Lubricate	SPL	2
400 Hours	T	1	Engine	Replace air filter	-	1
				Replace fuel filter	-	1
	T	20	Rear wheel bearings	Check, lubricate, and adjust	SPL	2
800 Hours	T	10	Hydraulic reservoir	Replace filler cap	-	1
	T	-	Hydraulic hoses	Check for wear and damage	-	All
	T	1, 18	Cooling system	Flush	WG	2
	T	13	Propelling motor	Torque shaft nut	-	1
	T	13	Front wheel	Torque wheel nuts	-	1
	T	15	Battery	Clean and tighten battery cable connections	-	1

LUBRICANT/FLUID

EO Engine oil, 5W30 SAE-SG/SH only.

HYDO . . **TennantTrue** premium hydraulic fluid or equivalent

WG . . . Water and ethylene glycol anti-freeze, -34° C (-30° F)

SPL . . . Special lubricant, Lubriplate EMB grease (Tennant part number 01 433-1)

NOTE: More frequent maintenance intervals may be required in extremely dusty conditions.

The table below indicates the *Person Responsible* for each procedure.

O = Operator.

S = Trained Service Mechanic.

Interval	Person Resp.	Key	Description	Procedure	Lubricant/ Fluid	No. of Service Points
1000 Hours	T	16	FaST system filters	Replace	–	2
	T	1	Engine	Replace spark plugs	–	4
	T	1	Engine	Inspect PCV system	–	1
	T	1, 19	Radiator hoses	Check for cracks or deterioration	–	2
1200 Hours	T	10	Hydraulic reservoir	* Replace fluid filter	–	1
2400 Hours	T	10	Hydraulic reservoir	* Change hydraulic fluid	HYDO	1
				* Replace strainer outlet		1
5000 Hours	T	1	Engine	Replace camshaft and balance shaft belts	–	2

LUBRICANT/FLUID

EO Engine oil, 5W30 SAE–SG/SH only.

HYDO . **TennantTrue** premium hydraulic fluid or equivalent

WG Water and ethylene glycol anti-freeze, –34° C (–30° F)

SPL Special lubricant, Lubriplate EMB grease (Tennant part number 01433–1)

NOTE: More frequent maintenance intervals may be required in extremely dusty conditions.

YELLOW TOUCH POINTS

This machine features easy to find yellow touch points for simple service items. No tools are required to perform these maintenance operations.

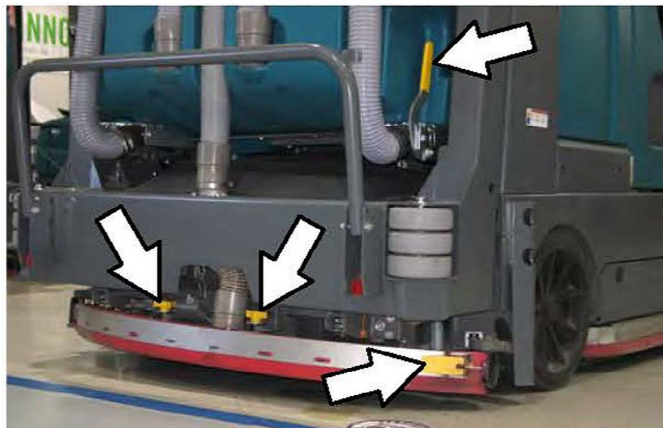

LUBRICATION

FOR SAFETY: Before leaving or servicing machine, stop on level surface, set parking brake, turn off machine, and remove key.

ENGINE OIL

Check the engine oil level daily. Change the oil and oil filter after every 100 hours of operation.



Fill the engine with oil until the oil is between the indicator marks on the dipstick. DO NOT fill past the top indicator mark.

The engine oil capacity for **Mitsubishi engines** is 4.7 L (5 qt) with oil filter.

SQUEEGEE CASTER BEARINGS

Lubricate the squeegee caster bearings after every 100 hours of operation.



FRONT WHEEL SUPPORT BEARING

Lubricate the front wheel support bearings after every 200 hours of operation. Both front wheel support grease fittings are located underneath the frame support plate.



STEERING CYLINDER BEARING

Lubricate the steering cylinder after every 200 hours of operation. The steering cylinder bearing is located next to the front wheel support.



REAR WHEEL BEARINGS

Inspect the rear wheel bearings for seal damage, and repack and adjust every 400 hours of operation. Use Lubriplate EMB grease (Tennant part number 01433-1).

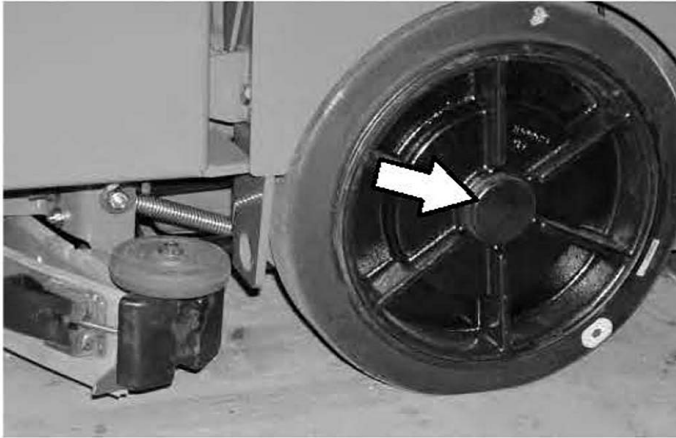

TORQUE TUBES

Lubricate the torque tubes after every 200 hours of operation. The torque tube grease fittings on the operator side of the machine are located beneath the fuel tank.



HOPPER LIFT ARM PIVOTS

Lubricate the hopper lift arm pivots after every 200 hours of operation.



On the other side of the machine the torque tube grease fittings are located beneath the propel pump.



HOPPER DOOR PIVOTS

Lubricate the hopper door pivots after every 200 hours of operation.



HYDRAULICS

Check the hydraulic fluid level at operating temperature daily. The hydraulic fluid level should be between the two lines on the hydraulic gauge. The hopper must be down when checking hydraulic fluid level.

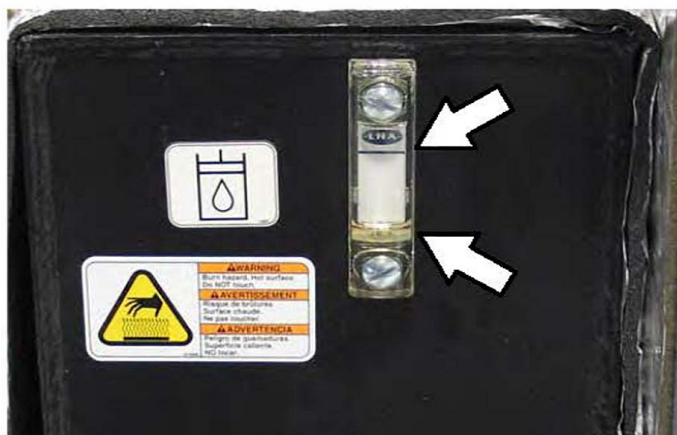

ATTENTION! Do not overfill the hydraulic fluid reservoir or operate the machine with a low level of hydraulic fluid in the reservoir. Damage to the machine hydraulic system may result.

Drain and refill the hydraulic fluid reservoir with new **TennantTrue** premium hydraulic fluid after every 2400 hours of operation.

WARNING: Burn hazard. Hot surface. Do NOT touch.

Replace the filler cap after every 800 hours of operation. Apply a light film of hydraulic fluid onto the filler cap gasket before installing the cap onto the reservoir.



Replace the hydraulic fluid filter after every 1200 hours of operation or if the hydraulic reservoir gauge is in the yellow/red zone when the reservoir hydraulic fluid is approximately 32° C (90° F).



Replace the hydraulic strainer outlet after every 2400 hours of operation.

HYDRAULIC FLUID

There are three fluids available for different ambient air temperature ranges:

TennantTrue premium hydraulic fluid (Extended Life)			
Part Number	Capacity	ISO Grade Viscosity Index (VI)	Ambient Air Temperature Ranges
1057710	3.8 L (1 gal)	ISO 100 VI 126 or higher	19° C (65° F) or higher
1057711	19 L (5 gal)		
1069019	3.8 L (1 gal)	ISO 68 VI 155 or higher	7 to 43° C (45 to 110° F)
1069020	19 L (5 gal)		
1057707	3.8 L (1 gal)	ISO 32 VI 163 or higher	16° C (60° F) or lower
1057708	19 L (5 gal)		

If using a locally-available hydraulic fluid, be sure the specifications match Tennant hydraulic fluid specifications. Substitute fluids can cause premature failure of hydraulic components.

ATTENTION! Hydraulic components depend on system hydraulic fluid for internal lubrication. Malfunctions, accelerated wear, and damage will result if dirt or other contaminants enter the hydraulic system.

HYDRAULIC HOSES

Check the hydraulic hoses after every 800 hours of operation for wear or damage.

FOR SAFETY: When servicing machine, use cardboard to locate leaking hydraulic fluid under pressure.

High pressure fluid escaping from a very small hole can almost be invisible, and can cause serious injuries.

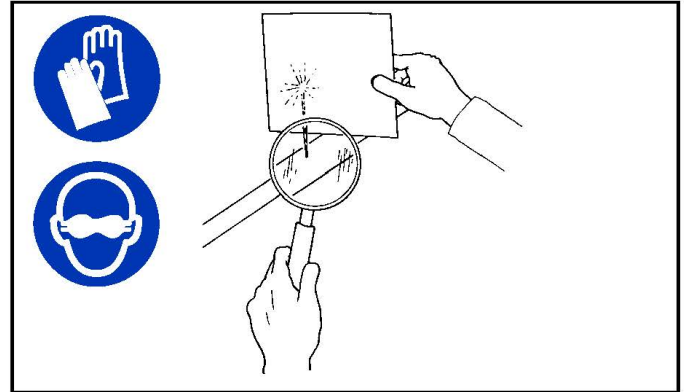

00002

Consult a physician immediately if injury results from escaping hydraulic fluid. Serious infection or reaction can occur if proper medical treatment is not given immediately.

Contact a mechanic or supervisor if a leak is discovered.

ENGINE

FOR SAFETY: Before leaving or servicing machine, stop on level surface, set parking brake, turn off machine, and remove key.

COOLING SYSTEM

FOR SAFETY: When servicing machine, avoid contact with hot engine coolant. Do not remove cap from radiator when engine is hot. Allow engine to cool.

Check the coolant level in the reservoir daily. The coolant level must be between the indicator marks when the engine is cold. Refer to the coolant manufacture for water/coolant mixing instructions.



Flush the radiator and the cooling system after every 800 hours of operation.

Check the radiator hoses and clamps after every 200 hours of operation. Tighten loose clamps. Replace damaged hoses and clamps.

Check the radiator hoses for cracks and deterioration after every 1000 hours of operation.

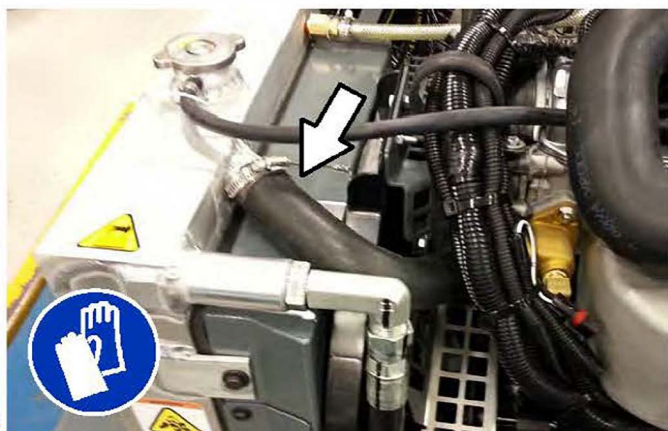

Check the radiator core exterior and hydraulic cooler fins for debris after every 100 hours of operation. Blow or rinse all dust through the grille and radiator fins, in the opposite direction of normal air flow. Be careful to not bend the cooling fins when cleaning. Clean thoroughly to prevent the fins from becoming encrusted with dust. To avoid cracking the radiator, allow the radiator and cooler fins to cool before cleaning.

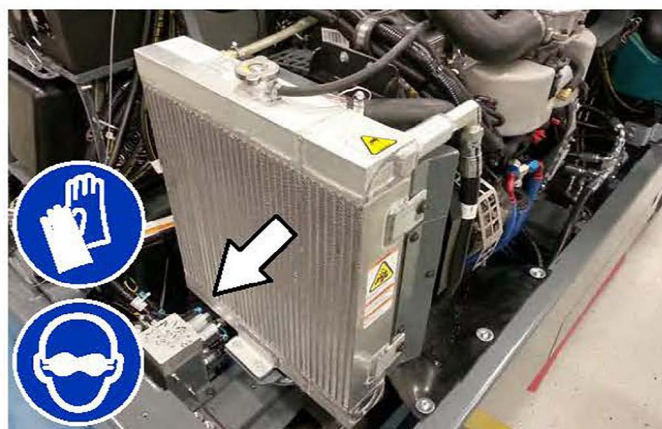

FOR SAFETY: When servicing machine, wear eye and ear protection when using pressurized air or water.

AIR FILTER

Replace the air filter after every 400 hours of operation.



FUEL FILTER (LPG)

Replace the LPG fuel filter after every 400 hours of operation.

Disassemble the fuel lock off valve to access the LPG fuel filter.

FOR SAFETY: When servicing machine, keep flames and sparks away from fuel system service area. Keep area well ventilated.

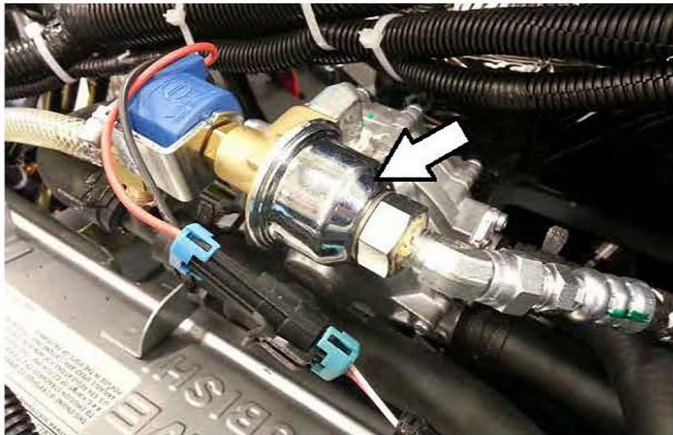

FUEL FILTER (Gasoline)

Replace the gasoline fuel filter after every 400 hours of operation.

FOR SAFETY: When servicing machine, keep flames and sparks away from fuel system service area. Keep area well ventilated.

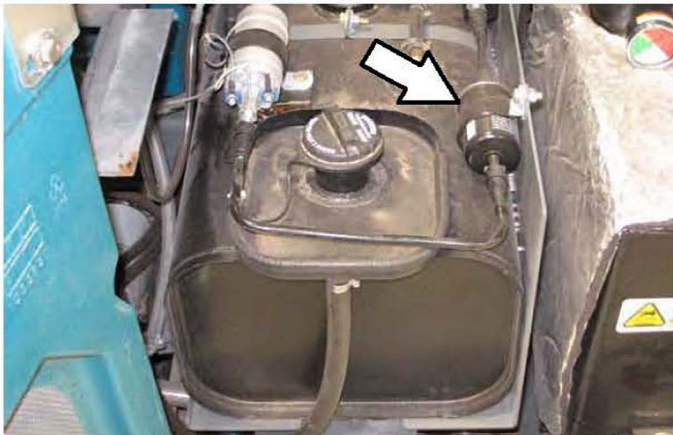

LPG VAPORIZER

Drain oil buildup in the LPG vaporizer after every 100 hours of operation.

FOR SAFETY: When servicing machine, keep flames and sparks away from fuel system service area. Keep area well ventilated.



ENGINE BELT

Check the belt tension after every 50 hours of operation. Adjust tension as necessary. Proper belt tension is 13 mm (0.50 in) from a force of 4 to 5 kg (8 to 10 lb) applied at the mid-point of the longest span.

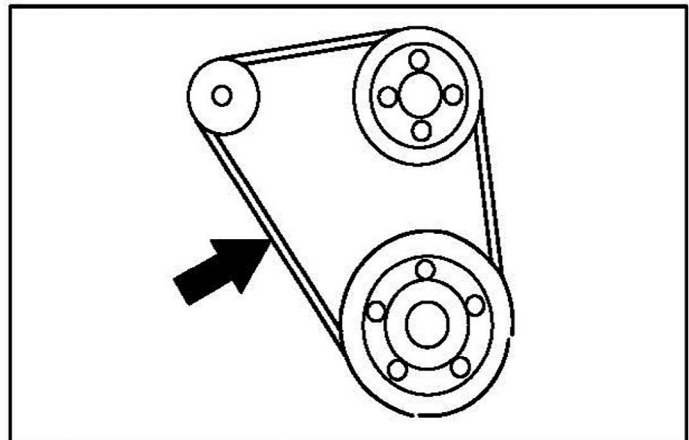

WARNING: Moving belt and fan. Keep away.

PCV SYSTEM

Inspect the PCV system after every 1000 hours of operation.



SPARK PLUGS

Replace the spark plugs after every 1000 hours of operation.

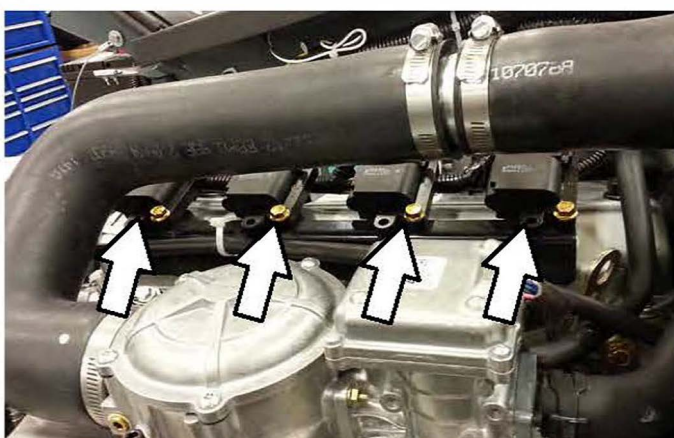

CAMSHAFT AND BALANCE SHAFT BELTS

Replace the camshaft and balance shaft belts after every 5000 hours of operation.

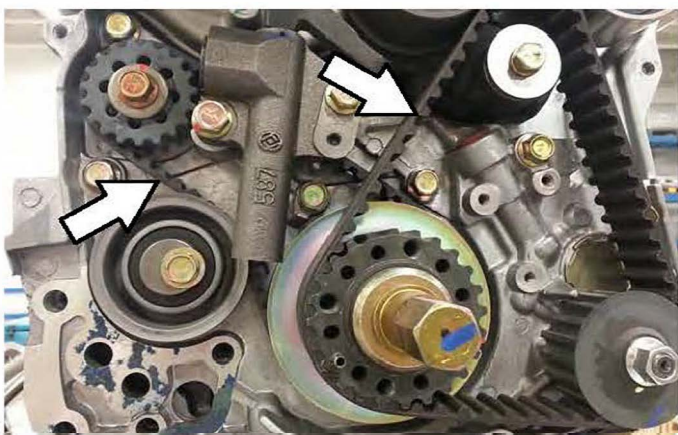

BATTERY

Clean and tighten the battery connections after the first 50 hours of operation and after every 800 hours after that. Do not remove the vent plugs from the battery or add water to the battery.

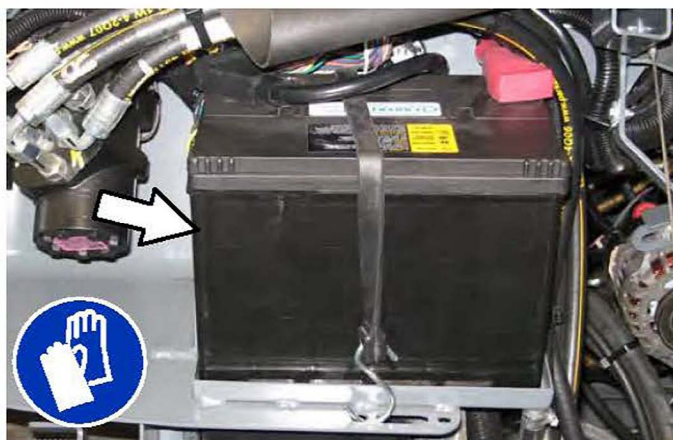

FOR SAFETY: When servicing machine, avoid contact with battery acid.

FUSES AND RELAYS

RELAY PANEL FUSES AND RELAYS

Fuses are one-time protection devices designed to protect the wire harness by stopping the flow of current in the event of a circuit overload. *Relays* switch the electrical power going to the machine electrical systems on/off. Remove the relay panel cover to access *fuses* and *relays*.

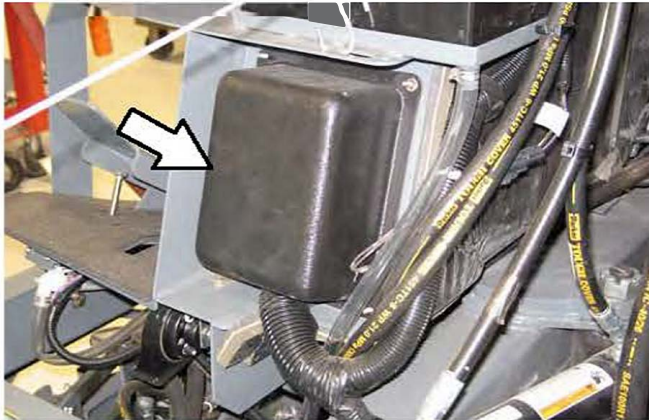

NOTE: Always replace a fuse with a fuse of the same amperage. Extra 15 Amp fuses are provided inside the relay panel drawer on the relay panel.

Refer to the diagram below for locations of the *fuses* and *relays* on the relay panel.

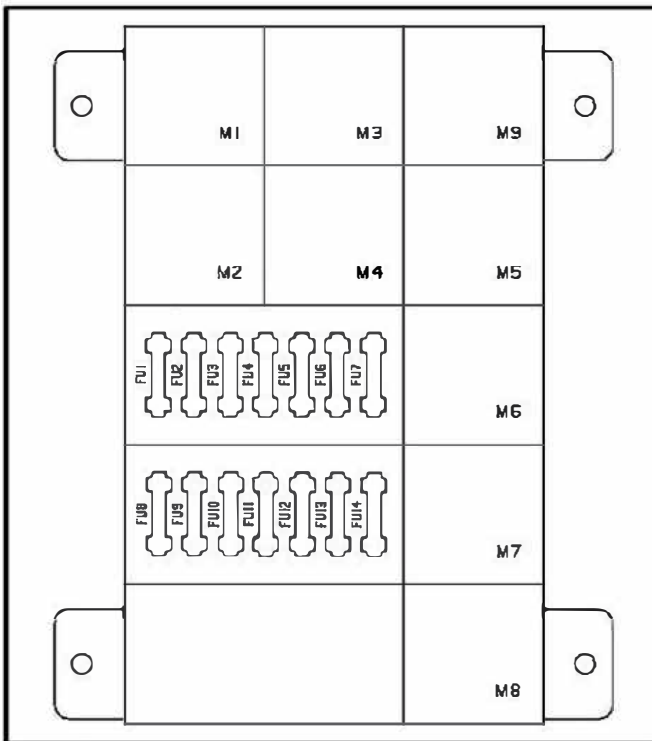

Refer to the table below for the *fuses* and circuits protected.

Fuse	Rating	Circuit Protected
FU1	15 A	Auxiliary Relays/Engine Controls
FU2	15 A	Shaker
FU3	15 A	Horn
FU4	15 A	Not Used
FU5	15 A	Scrub Vacuum/Main Brush/Squeegee Down/Hopper Up
FU6	15 A	Enable/Side Brush/Sweep Vacuum
FU7	15 A	Solution/Hopper Latch and Door/Auto Fill/Reverse/Shaker
FU8	15 A	ES/FaST/Detergent/Hopper Down/Spray Wand
FU9	15 A	Lights
FU10	15 A	Unswitched B+ for controller board
FU11	15 A	Not Used: Options
FU12	15 A	Spray Nozzle Pump
FU13	15 A	AC/Heater Option
FU14	15 A	Not Used

-	20 A	ec-H2O (near ignition switch)
---	------	-------------------------------

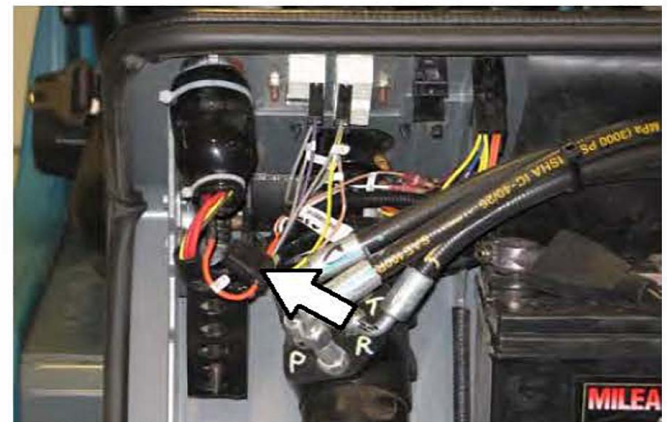

Refer to the table below for the *relays* and circuits controlled.

Relay	Rating	Circuit Controlled
M1	12 VDC, 40 A	Auxiliary 1
M2	12 VDC, 40 A	Auxiliary 2
M3	12 VDC, 40 A	Shaker
M4	12 VDC, 40 A	Reverse
M5	12 VDC, 40 A	Horn
M6	12 VDC, 40 A	Shutdown
M7	12 VDC, 40 A	Starter
M8	12 VDC, 40 A	Auxiliary 3
M9	12 VDC, 40 A	Spare

ENGINE HARNESS FUSES AND RELAYS

The *engine harness fuses and relays* are located in the fuse box inside the engine compartment. Refer to the fuse box cover for locations of engine harness fuses and relays.



NOTE: Always replace a fuse with a fuse of the same amperage.

OPTIONAL RELAYS

The optional spray nozzle or pressure wand relay is located behind the battery. The optional FaST scrubbing system relay is located behind the seat.

Relay	Rating	Circuit Controlled
-	12 VDC. 40 A	Spray Wand
-	12 VDC. 40 A	Pressure Washer
-	12 VDC. 40 A	FaST

CIRCUIT BREAKERS (*ec-H2O*)

Circuit breakers are resettable electrical circuit protection devices that stop the flow of current in the event of a circuit overload. Once a circuit breaker is tripped, allow breaker to cool and then press the reset button to manually reset the breaker.



CLEANING THE HOPPER DUST FILTER

Shake the dust filter before emptying the hopper and at the end of every shift. Inspect and clean the filter after every 20 hours of operation. Replace damaged dust filters.

NOTE: The dust filter may need to be cleaned at more frequent intervals if the machine is used in extremely dusty conditions.

Use one of the following methods to clean the dust filter:

SHAKING—Press the *filter shaker button*.

TAPPING—Tap the filter, with the dirty side down, gently on a flat surface. **Do not damage the edges of the filter.** The filter will not seal properly in the filter frame if the edges of the filter are damaged.

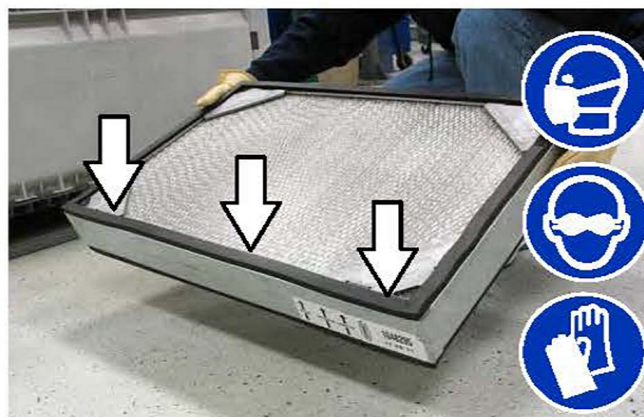

AIR—Always wear eye protection when using compressed air. Blow air through the dust filter opposite the direction of the arrows. Never use more than 690 kPa (100 psi) of air pressure and never hold the nozzle closer than 50 mm (2 in) to the filter. This may be done with the dust filter in the machine.

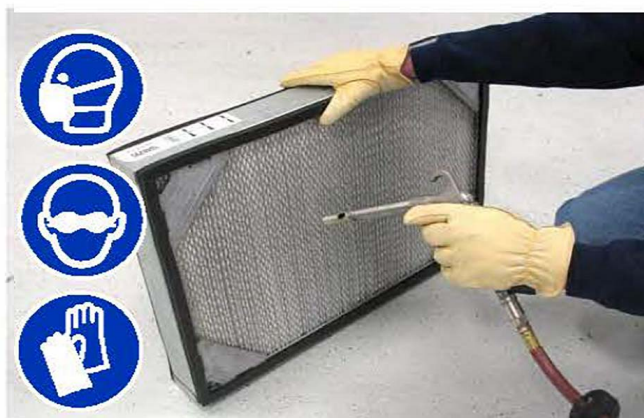

MAINTENANCE

WATER—Rinse the dust filter with a low pressure garden hose through the dust filter opposite the direction of the arrows.



NOTE: If water is used to clean the dust filter, be sure the filter is completely dry before reinstalling it into the hopper. **Do Not** reinstall a wet dust filter.

THERMO-SENTRY

The Thermo-Sentry, located inside the hopper, senses the temperature of the air pulled up from the hopper. If there is a fire in the hopper, the Thermo-Sentry stops the vacuum fan and cuts off the air flow. The Thermo-Sentry automatically resets after cooling down.

MAIN BRUSHES

FOR SAFETY: Before leaving or servicing machine, stop on level surface, set parking brake, turn off machine, and remove key.

Check the main brushes daily for tangled wire or string, wear, and damage.

Replace the brushes when they no longer clean effectively.

Rotate the brushes from front to rear after every 50 hours of machine operation for maximum brush life and best scrubbing performance.

NOTE: Replace brushes in sets of two. Otherwise one scrub brush may scrub more aggressively than the other.

REPLACING OR ROTATING THE MAIN BRUSHES

The front brush can be accessed on the left side of the machine and rear brush can be accessed on the right side of the machine.

1. Raise the scrub head.

FOR SAFETY: Before leaving or servicing machine, stop on level surface, set parking brake, turn off machine, and remove key.

2. Open the outer brush doors.



3. Open the inner brush doors.



4. Remove the brush idler plates.

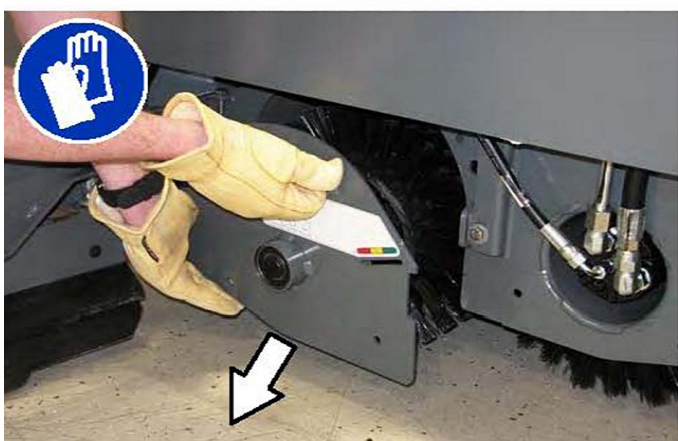

5. Pull the brushes out from the scrub head.



6. Install the new or rotated brushes by pushing down on the ends while sliding them onto the drive motor hubs.



7. If rotating the brushes, always rotate the front with the back so that they wear evenly. They may be rotated end-for-end as well.

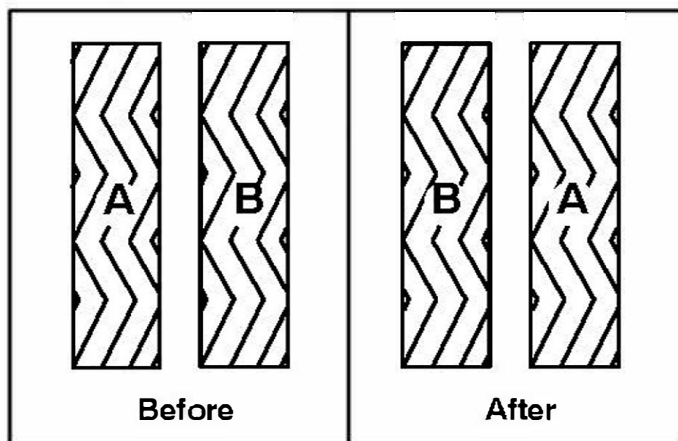

8. Reinstall the brush idler plates.

9. Close the inner and outer brush doors.

10. Check the brush pattern and adjust if needed after rotating them. Refer to *CHECKING AND ADJUSTING THE MAIN BRUSH PATTERN*.

CHECKING THE MAIN BRUSH PATTERN

1. Apply chalk, or a similar marking material, to a smooth and level section of the floor.

NOTE: If chalk or other material is not available, allow the brush to spin on the floor for two minutes. A polish mark will remain on the floor.

2. Raise the scrub head, then position the brushes over the chalked area.
3. Set the parking brake.
4. Press the *1-STEP Sweep button* to lower the scrub head. Set the brush pressure to the lowest setting and allow the brushes to operate for 15 to 20 seconds. Keep the scrub head in one spot in the chalked area.
5. Raise the scrub head, release the parking brake, and drive the machine away from the chalked area.

FOR SAFETY: Before leaving or servicing machine, stop on level surface, set parking brake, turn off machine, and remove key.

6. Observe the brush patterns. If the brush pattern is the same width across the entire length of each brush and both brushes are the same width, no adjustment is necessary.

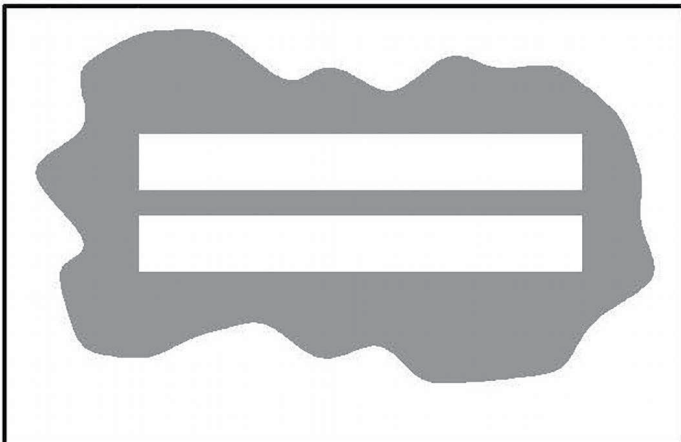

7. If the brush patterns are tapered, see *ADJUSTING THE MAIN BRUSH TAPER* section of this manual.

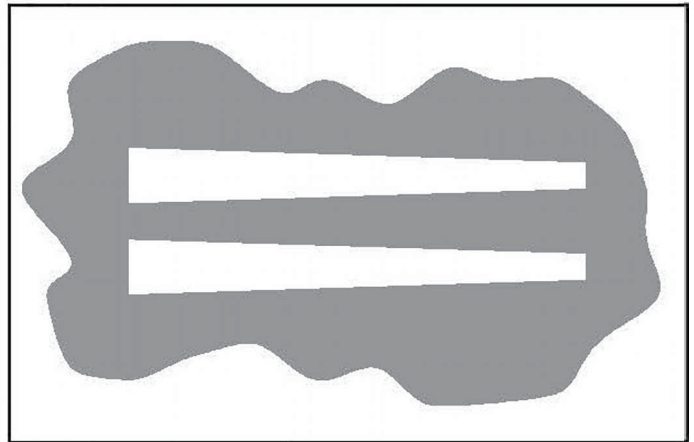

8. The brush patterns should be 50 to 75 mm (2 to 3 in) wide with the brushes in the lowered position and both patterns should be the same width. If the width of the brushes is not the same, see *ADJUSTING THE MAIN BRUSH WIDTH* section of this manual.

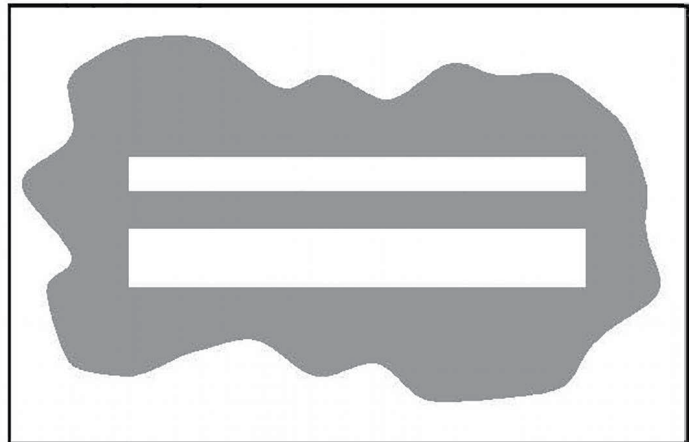

ADJUSTING THE MAIN BRUSH TAPER

1. Loosen the four mounting bolts on the brush drive housing.

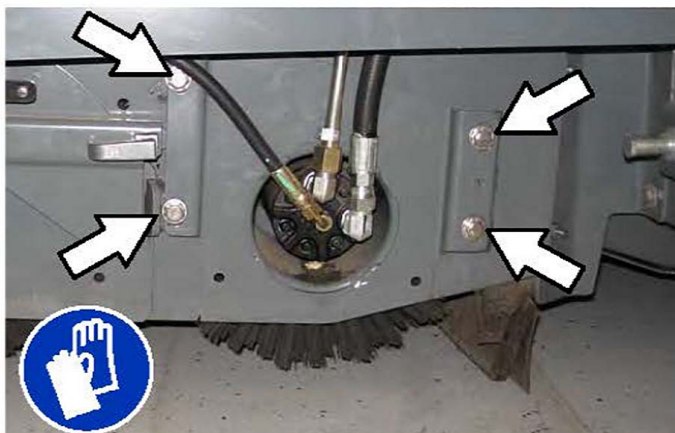

2. Move the brush drive housing up to decrease the pattern width on that side of the scrub head or down to increase the pattern width on that side of the scrub head.
3. Tighten the mounting bolts.
4. Recheck the pattern. Readjust if necessary.

ADJUSTING THE MAIN BRUSH WIDTH

1. Adjust the length of the drag links on both sides of the scrub head. Lengthen the drag links to increase the rear brush pattern width. Shorten the drag links to increase the front brush pattern. Always adjust the nut on each drag link an equal number of turns.

NOTE: Two full turns of the drag link adjustment bolt will change the brush pattern approximately 25 mm (1 in).



2. Recheck the pattern. Readjust if necessary.

SIDE BRUSH (OPTION)

FOR SAFETY: Before leaving or servicing machine, stop on level surface, set parking brake, turn off machine, and remove key.

Check the side brush daily for wear or damage. Remove any tangled string or wire from the side brush or side brush drive hub.

REPLACING THE SIDE BRUSH

Replace the brush when it no longer cleans effectively or when the bristles are worn down to the yellow indicators.

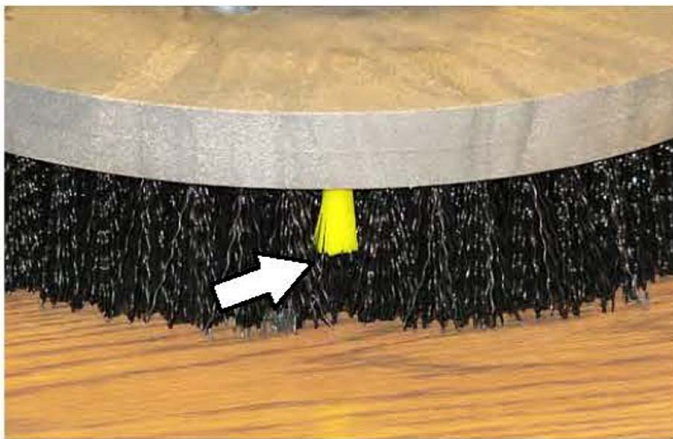

1. If necessary, raise the side brush.
2. Turn the brush until the spring handles are visible through the access hole in the side brush assembly.
3. Squeeze the spring handles and let the side brush drop to the floor.

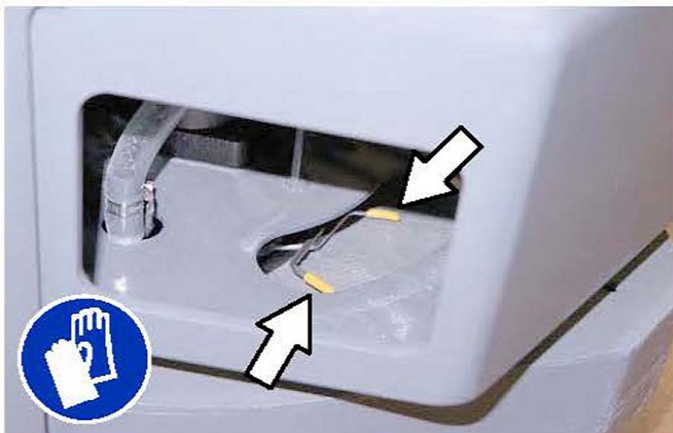

4. Remove the side brush from underneath the side brush assembly.



5. Set the brush spring open on the new brush to make installation easier.

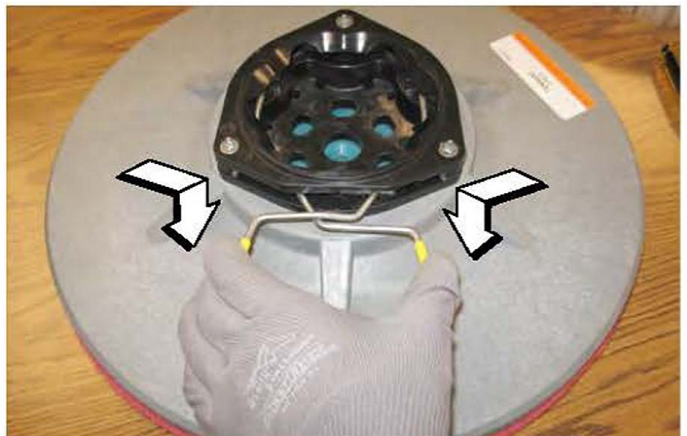

6. Place the new side brush underneath the side brush assembly and lift the side brush up onto the side brush hub until the brush locks onto the hub.

FaST SYSTEM

REPLACING THE FaST-PAK CARTON

FOR SAFETY: Before leaving or servicing machine, stop on level surface, set parking brake, turn off machine, and remove key.

1. Open the side access door.
2. Slide the seat completely forward.
3. Squeeze the button on the FaST supply hose connector, then pull the empty FaST-PAK carton out from the compartment and discard.



4. Remove the perforated knock outs from the new FaST-PAK carton. Do Not remove the bag from the carton. Pull out the hose connector located on the bottom of the bag and remove the hose cap from the connector.

NOTE: The FaST-PAK Floor Cleaning Concentrate is specially designed for use with the FaST system scrubbing application. NEVER use a substitute. Other cleaning solutions may cause FaST system failure.

5. Slide the FaST-PAK carton into the FaST-PAK bracket.
6. Connect the FaST supply hose to the FaST-PAK hose connector.
7. Scrub with the FaST system for a few minutes to allow the detergent to reach maximum foaming.

CLEANING THE FaST SUPPLY HOSE CONNECTOR

Soak the connector in warm water if detergent buildup is visible. When a FaST-PAK carton is not installed, store the supply hose connector on the storing plug to prevent the hose from clogging.



CLEANING THE FaST SYSTEM FILTER SCREEN

The FaST system filter screen filters water from the solution tank as the water flows into the FaST system.

Remove the filter screen bowl and clean the filter screen after every 50 hours of operation. Empty the solution tank before removing the filter.

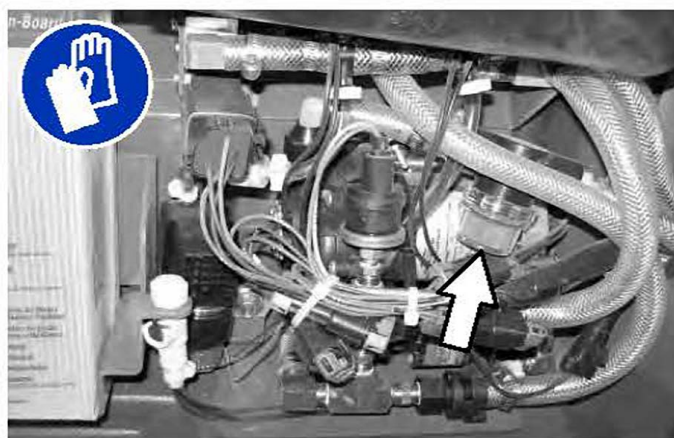

REPLACING THE FaST SYSTEM FILTERS

Replace the FaST system filters after every 1000 hours of operation. Empty the solution tank before replacing the filters.

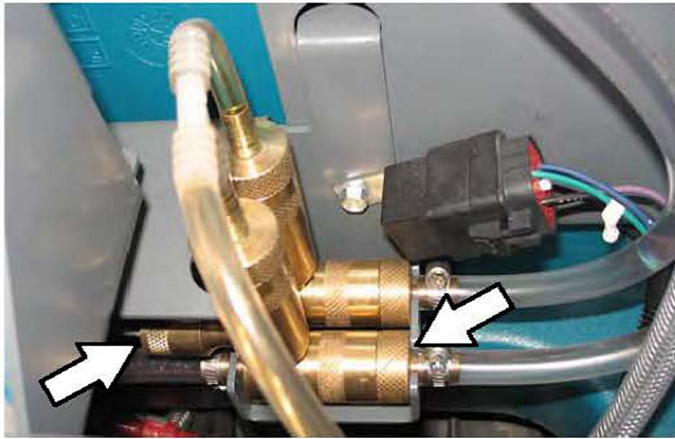

3. Disconnect the *ec-H2O* system intake hose from the solution supply hose and connect the intake flush hose (gray connector) to the *ec-H2O* system intake hose.



4. Disconnect the *ec-H2O* system outlet hose from the hose to the scrub head and connect the outlet flush hose (black connector) to the *ec-H2O* system outlet hose.



***ec-H2O* MODULE FLUSH PROCEDURE**

This procedure is only required when an alarm sounds and the *ec-H2O* system indicator light begins to blink red.

FOR SAFETY: Before leaving or servicing machine, stop on level surface, set parking brake, turn off machine.

1. Remove both flush hoses from the storage bag located behind the operator seat.
2. Lock the operator seat cover open.

5. Place the *ec-H2O* system intake hose into a container containing 5 gallons (19 liters) of white or rice vinegar. Place the outlet hose into an empty container.



6. Turn the key to the on position without starting the engine.
7. Press and release the *ec-H₂O* module flush switch to start the flush cycle.

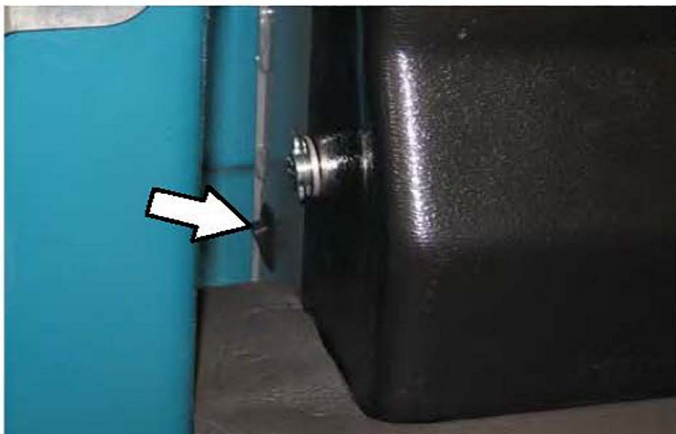

NOTE: The module will automatically shut off when the flush cycle is complete (approx. 7 minutes). The module must run the full 7 minute cycle in order to reset the system indicator light and alarm.

8. After the 7 minute flush cycle, remove the siphon hose from the container of vinegar and place the siphon hose into a container of cool clean water. Press the flush switch again to rinse out any remaining vinegar from the module. After 1–2 minutes, press the flush switch to turn off the module.
9. Disconnect the flush hoses from the *ec-H₂O* system intake hose and outlet hose and return the flush hoses to the storage bag.
10. Reconnect *ec-H₂O* intake and outlet hoses. If the *ec-H₂O* system indicator light continues to flash, repeat the flush procedure. If the problem persists, contact an Authorized Service Center.
11. Close the operator seat cover.

CLEANING THE *ec-H₂O* FILTER SCREEN

Remove and clean the *ec-H₂O* filter screen after every 50 hours of operation.



SQUEEGEE BLADES

FOR SAFETY: Before leaving or servicing machine, stop on level surface, set parking brake, turn off machine, and remove key.

Check the squeegee blades for damage and wear daily. When the blades become worn, rotate the blades end-for-end or top-to-bottom to a new wiping edge. Replace blades when all edges are worn.

Check the deflection of the squeegee blades daily or when scrubbing a different type of surface. Check the leveling of the rear squeegee every 100 hours of operation.

REPLACING (OR ROTATING) THE REAR SQUEEGEE BLADES

1. Lower the scrub head.
2. Disconnect the vacuum hose from the rear squeegee assembly.

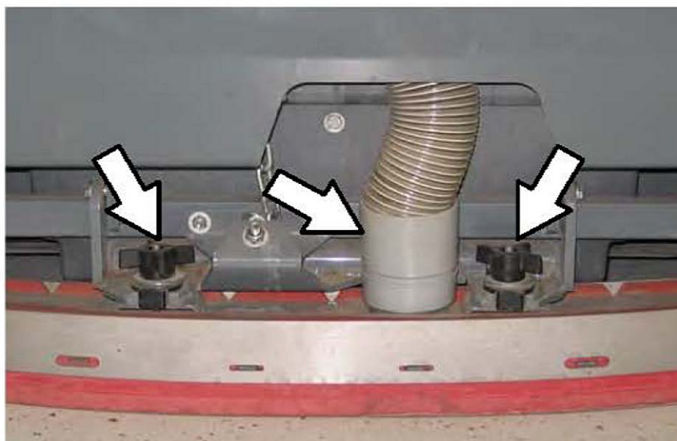

3. Remove both mounting knobs from the rear squeegee assembly.
4. Turn on the machine, raise the scrub head, and turn off the machine.
5. Remove the rear squeegee assembly from the machine.

6. Loosen the rear retaining band tension latch and open the retaining band.

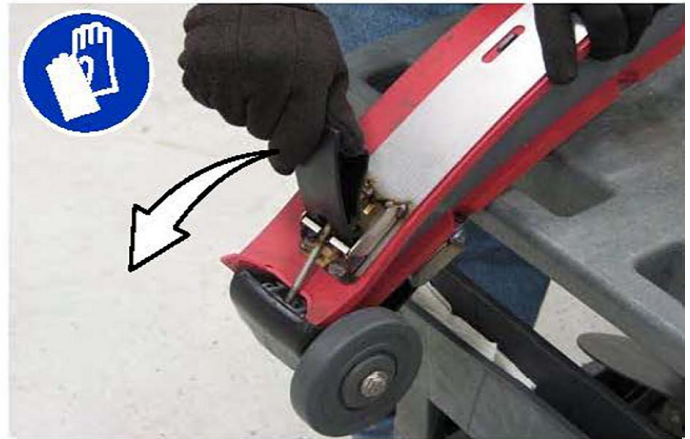

7. Remove the rear squeegee.



8. Install the new rear squeegee blade or rotate the existing blade to the new edge. Be sure all the holes in the squeegee blade are hooked onto the tabs.



9. Reinstall the rear retaining band aligning the tabs with the holes.



10. Tighten the rear retaining band tension latch.

11. Loosen the front retaining band tension latch and open the retaining band.



12. Remove the front squeegee.



13. Install the new front squeegee blade or rotate the existing blade to the new edge. Be sure the holes in the squeegee blade are hooked onto the tabs.



14. Reinstall the front retaining band aligning the tabs with the notches.



15. Tighten the front retaining band tension latch.
16. Reinstall the rear squeegee assembly onto the machine.
17. Check and adjust the rear squeegee if necessary. Refer to *ADJUSTING THE REAR SQUEEGEE BLADE DEFLECTION* and *LEVELING THE REAR SQUEEGEE* sections of this manual.

REPLACING OR ROTATING THE SIDE SQUEEGEE BLADES

1. If necessary, raise the scrub head.

FOR SAFETY: Before leaving or servicing machine, stop on level surface, set parking brake, turn off machine, and remove key.

2. Open the outer brush doors.
3. Unhook the latch on the side squeegee retaining band from the side squeegee assembly.

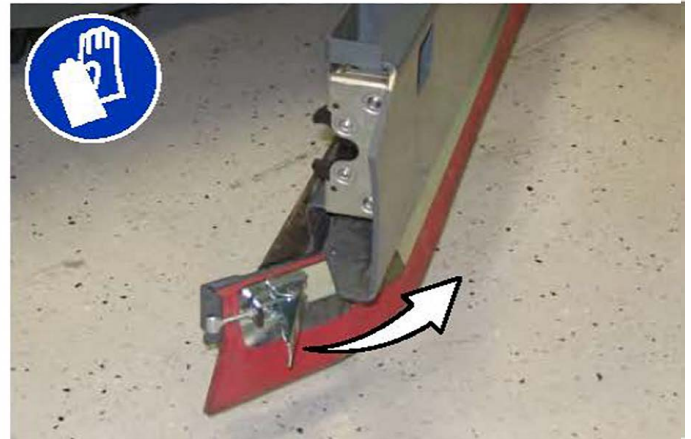

4. Remove the retaining band from the side squeegee assembly.



- Remove the side squeegee blade. If the outer edge of the squeegee blade is not worn, rotate the squeegee blade with the blade from the other side of the machine. Discard the squeegee blade if both edges are worn.

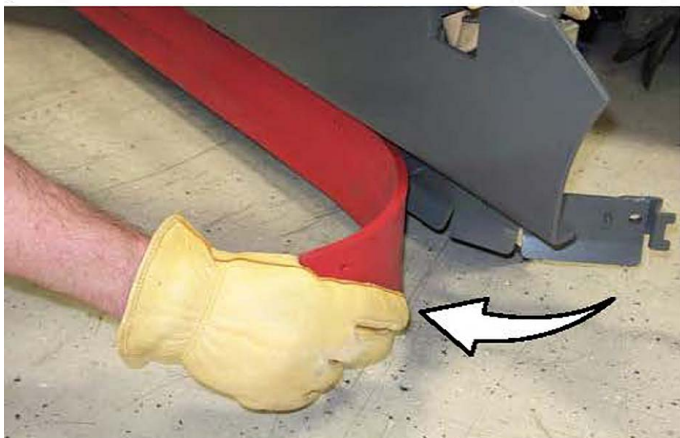

- Install the new or rotated squeegee blades.



- Reattach the side squeegee retaining band to the side squeegee assembly.



- Hook the latch on the side squeegee retaining band.

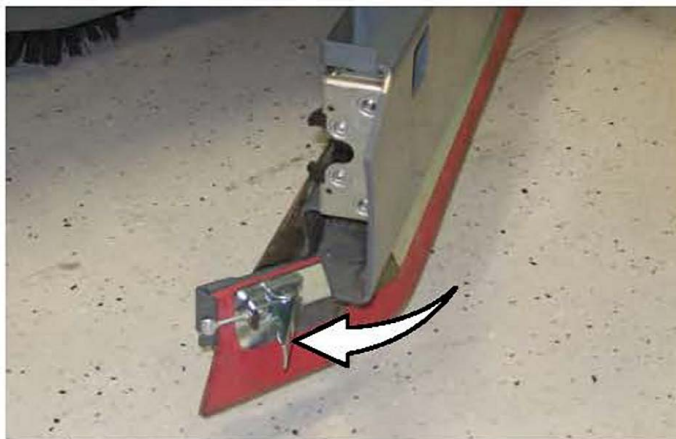

- Close the outer brush door.

REPLACING OR ADJUSTING THE SIDE BRUSH SQUEEGEE BLADE (OPTION)

FOR SAFETY: Before leaving or servicing machine, stop on level surface, set parking brake, turn off machine, and remove key.

Check the side brush squeegee blade for damage and wear daily. Replace the blade if the leading edge is torn or worn half-way through the thickness of the blade.

1. Lower the scrub head.
2. Pull the pins and remove the squeegee bumper.

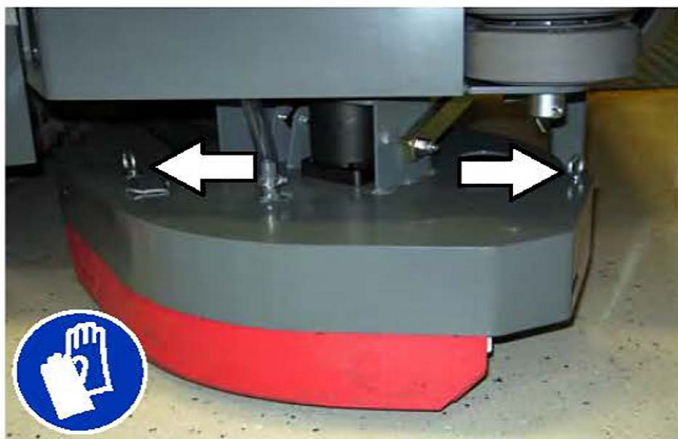

3. Open the retaining band tension latch.

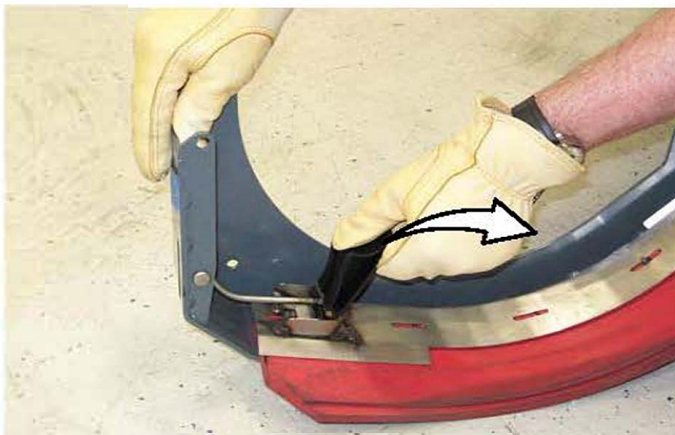

4. Remove the squeegees, spacer, and retainer from the squeegee bumper.

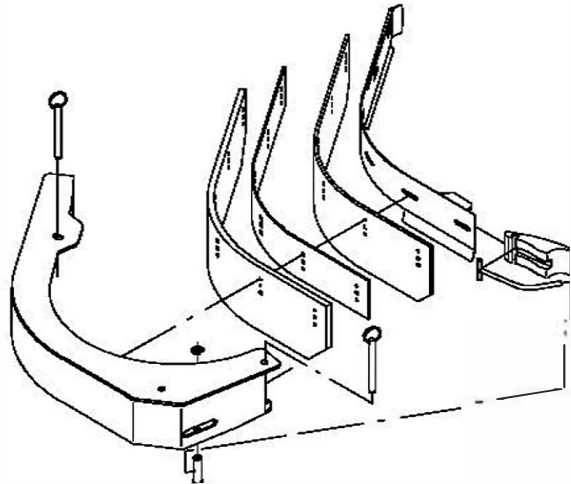

NOTE: The side brush squeegee blades have different holes for changing height adjustment.

5. Reinstall the squeegees, spacer, and retainer to the squeegee bumper by aligning the appropriate holes to the pins on the bumper.

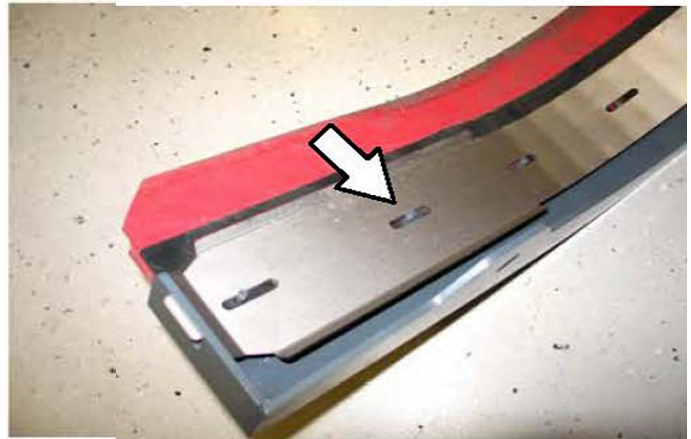

6. Reinstall the retaining band tension latch.
7. Reinstall the squeegee bumper and reinsert the pins.

LEVELING THE REAR SQUEEGEE

Leveling the squeegee assures the entire length of the squeegee blade is in even contact with the surface being scrubbed. Perform this adjustment on an even and level floor.

1. Lower the squeegee and drive the machine forward a few meters (feet).

FOR SAFETY: Before leaving or servicing machine, stop on level surface, set parking brake, turn off machine, and remove key.

2. Look at the deflection of the squeegee over the full length of the squeegee blade.
3. If the deflection is not the same over the full length of the blade, turn the squeegee levelling nut to make adjustments.

DO NOT disconnect the suction hose from the squeegee frame when leveling squeegee.

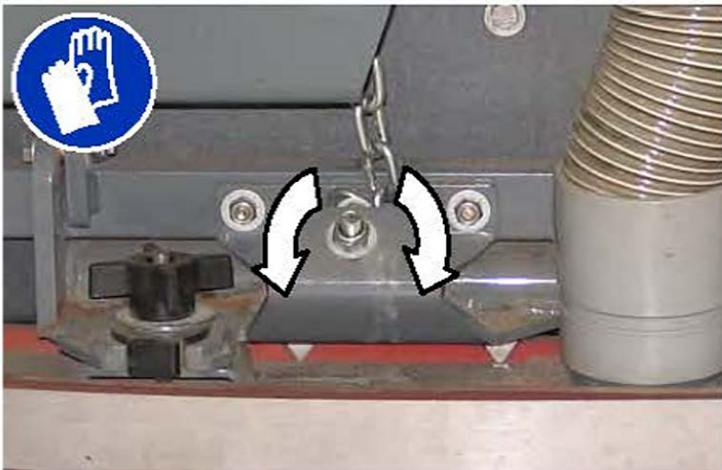

4. Turn the squeegee leveling nut counter-clockwise to decrease the deflection at the ends of the squeegee blade.

Turn the squeegee leveling nut clockwise to increase the deflection at the ends of the squeegee blade.

5. Drive the machine forward with the squeegee down to recheck the squeegee blade deflection if adjustments were made.
6. Readjust the squeegee blade deflection if necessary.

ADJUSTING THE REAR SQUEEGEE BLADE DEFLECTION

Deflection is the amount of curl the overall squeegee blade has when the machine moves forward. The best deflection is when the squeegee wipes the floor dry with a minimal amount of deflection.

NOTE: Make sure the squeegee is level before adjusting the deflection. See LEVELING THE REAR SQUEEGEE.

1. Lower the squeegee and drive the machine forward a few meters (feet).

FOR SAFETY: Before leaving or servicing machine, stop on level surface, set parking brake, turn off machine, and remove key.

2. Look at the amount of deflection or “curl” of the squeegee blade. The correct amount of deflection is 12 mm (0.50 in) for scrubbing smooth floors and 15 mm (0.62 in) for rough floors.

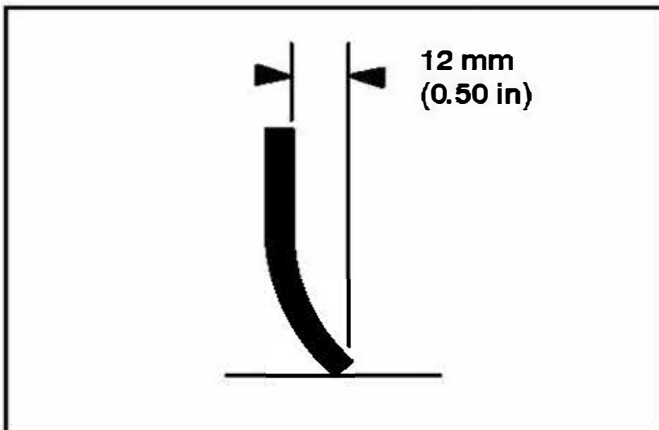

3. To adjust the overall squeegee blade deflection, turn the adjustment knobs counterclockwise to increase deflection or clockwise to decrease deflection.

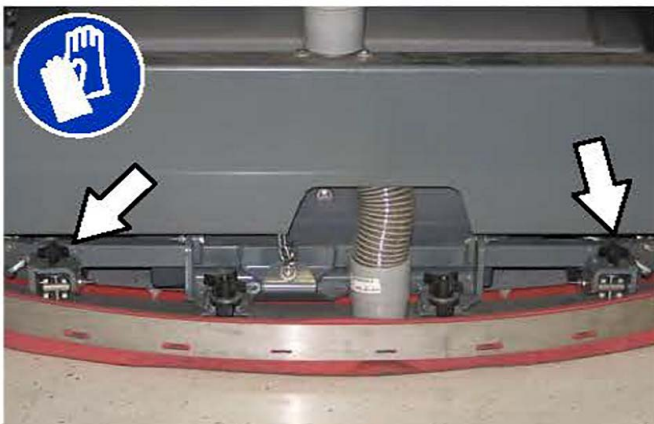

4. Drive the machine forward again to recheck the squeegee blade deflection after adjustments are made.
5. Readjust the squeegee blade deflection if necessary.

SKIRTS AND SEALS

FOR SAFETY: Before leaving or servicing machine, stop on level surface, set parking brake, turn off machine, and remove key.

SCRUB HEAD SKIRT

Check the skirt for damage and wear after every 100 hours of operation.



The skirts should be between 0 to 6 mm (0 to 0.25 in) from the floor when the scrub head is down.

RECOVERY TANK SEAL

Check the recovery tank cover seal for damage and wear daily.



SOLUTION TANK SEALS

Check each solution tank cover seal for damage and wear daily.



BRAKES AND TIRES

BRAKES

The mechanical brakes are located on the rear wheels. The brakes are operated by the foot brake pedal and connecting cables.

Check the brake adjustment after every 200 hours of operation.

To check the brake adjustment, measure the distance from the stationary brake pedal to the point where there is resistance in the pedal movement. The distance must be between 6 mm (0.25 in) and 19 mm (0.75 in). Adjust the brakes if required.

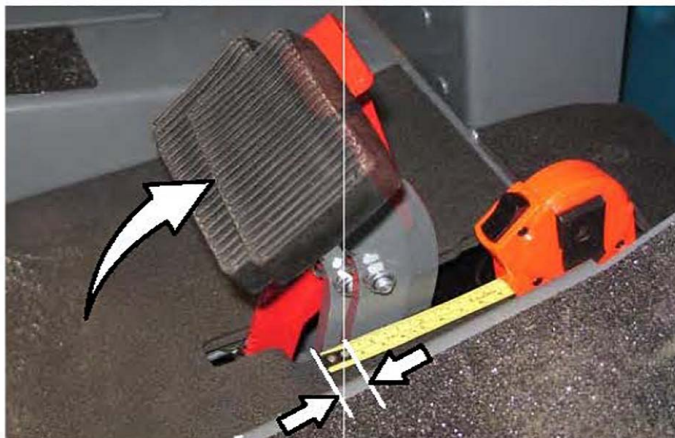

TIRES

Check tires for damage and wear after every 100 hours of operation.

FRONT WHEEL

Torque the front wheel nuts twice in the pattern shown to 122 to 149 Nm (90 to 110 ft lb) after the first 50 hours of operation, and after every 800 hours there after.

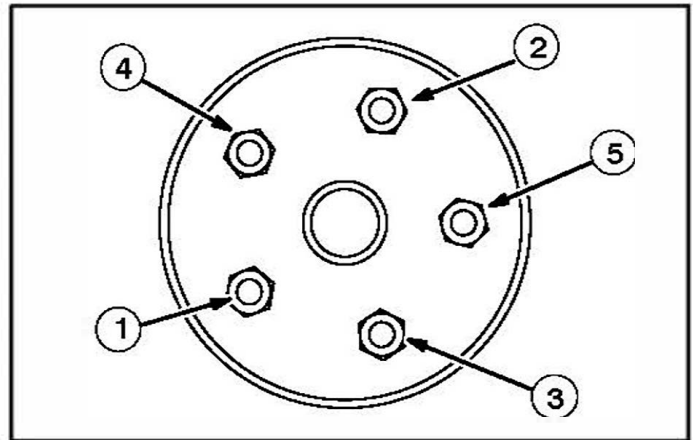

PROPELLING MOTOR

Torque the shaft nut to 508 Nm (375 ft lb) lubricated, 644 Nm (475 ft lb) dry, after every 800 hours of operation.



PUSHING, TOWING, AND TRANSPORTING THE MACHINE

PUSHING OR TOWING THE MACHINE

If the machine becomes disabled, it can be pushed from the front or rear, but only towed from the front.

The propelling pump has a bypass valve to prevent damage to the hydraulic system when the machine is being pushed or towed. This valve allows a disabled machine to be moved for a *very short distance* and at a speed to not exceed 1.6 kp/h (1 mph). The machine is NOT intended to be pushed or towed a long distance or at a high speed.

ATTENTION! Do not push or tow machine for a long distance or damage may occur to the propelling system.

Turn the bypass valve located on the bottom of the propelling pump 90° (either direction) from the normal position before pushing or towing the machine. Return the bypass valve back to the normal position when through pushing or towing the machine. **Do Not** use the bypass valve during normal machine operation.

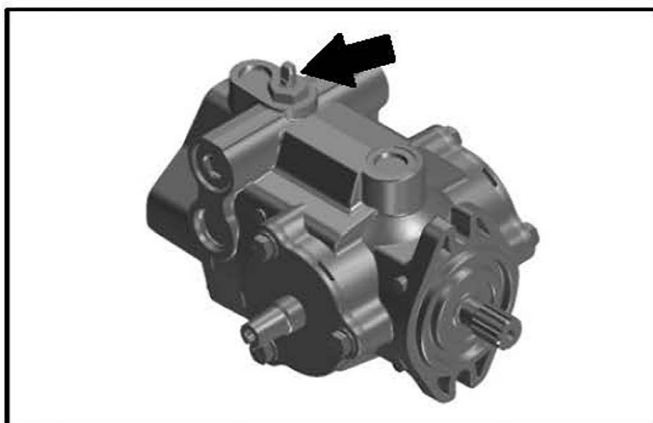

TRANSPORTING THE MACHINE

1. Raise the squeegee, scrub head, and brushes. If necessary, raise the hopper for additional ramp clearance.

FOR SAFETY: When loading machine onto truck or trailer, drain tanks and empty hopper before loading machine.

2. Position the rear of the machine at the loading edge of the truck or trailer.
3. If the loading surface is not horizontal or is higher than 380 mm (15 in) from the ground, use a winch to load machine.

If the loading surface is horizontal and 380 mm (15 in) or less from the ground, the machine may be driven onto the truck or trailer.

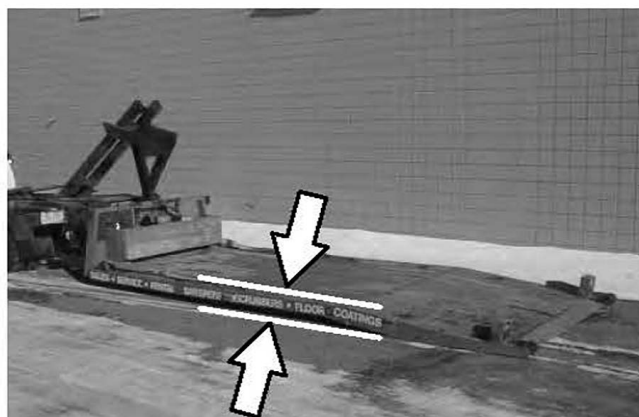

FOR SAFETY: When loading machine onto truck or trailer, use winch. Do not drive the machine onto the truck or trailer unless the loading surface is horizontal AND is 380 mm (15 in) or less from the ground.

4. To winch the machine onto the truck or trailer, attach the winching chains to the holes in the rear jacking brackets behind the rear tires.



MAINTENANCE

5. Position the machine as close to the front of the trailer or truck as possible.
6. Set the parking brake and place a block behind each wheel to prevent the machine from rolling.
7. Lower the scrub head.

FOR SAFETY: When loading/unloading machine onto/off truck or trailer, lower scrub head and squeegee before tying down machine.

8. Connect the tie-down straps to the holes in the right and left lower corners in front of the machine and the holes in the rear jacking brackets behind the rear tires.



9. Route the tie-downs to the opposite ends of the machine and hook them to the brackets on the floor of the trailer or truck. Tighten the tie-down straps.

NOTE: It may be necessary to install tie-down brackets to the floor of the trailer or truck.



10. If the loading surface is not horizontal or is higher than 380 mm (15 in) from the ground, use a winch to unload machine.

If the loading surface is horizontal AND is 380 mm (15 in) or less from the ground, the machine may be driven off the truck or trailer.

FOR SAFETY: When unloading machine off truck or trailer, use winch. Do not drive the machine off the truck or trailer unless the loading surface is horizontal AND 380 mm (15 in) or less from the ground.

MACHINE JACKING

Empty the hopper, recovery tank, and solution tank before jacking up the machine. Jack up the machine at the designated locations. Use a hoist or jack capable of supporting the weight of the machine. Use jackstands to support the machine. Always stop the machine on a flat, level surface and block the tires before jacking up the machine.

Rear jacking locations are located directly behind the rear tires on each side of the machine.

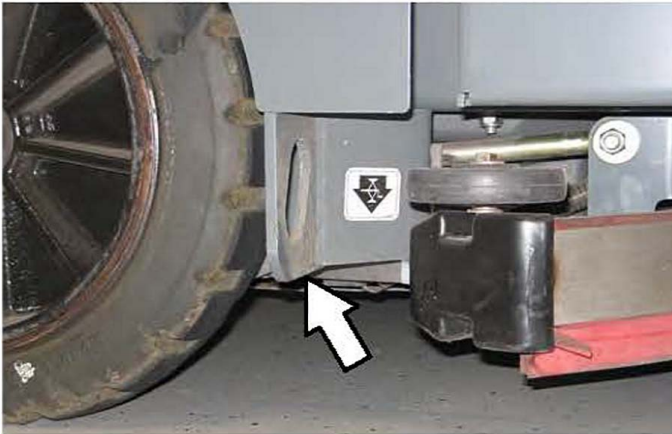

Front jacking locations are located on the frame directly in front of the front tire.

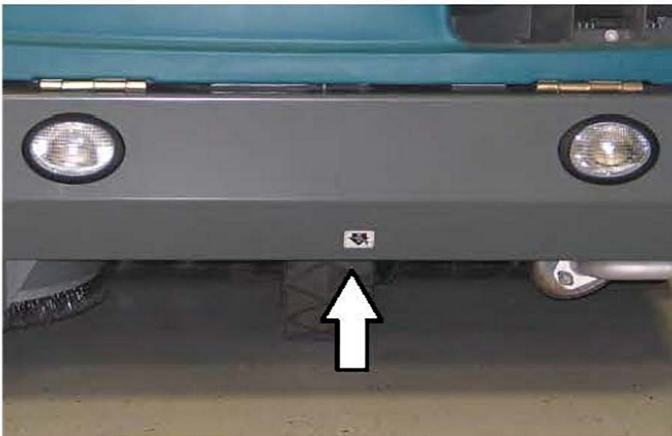

FOR SAFETY: Before leaving or servicing machine, stop on level surface, set parking brake, turn off machine, and remove key.

FOR SAFETY: When servicing machine, block machine tires before jacking machine up. Use a hoist or jack that will support the weight of the machine. Jack machine up at designated locations only. Support machine with jack stands.

STORAGE INFORMATION

The following steps should be taken prior to storing the machine for extended periods.

1. Drain and clean the solution and recovery tanks. Open the recovery tank and solution tank covers to allow the air to circulate.
2. Park the machine in a cool, dry area. Do not expose the machine to rain. Store indoors.
3. Remove the battery, or charge battery every three months.

FREEZE PROTECTION (MACHINES WITHOUT ec-H₂O SYSTEM)

FOR SAFETY: Before leaving or servicing machine, stop on level surface, set parking brake, and turn off machine.

1. Be sure the solution tank and recovery tank are empty.
2. Pour 3.8 L (1 gal) of Propylene Glycol Based / Recreational Vehicle (RV) Antifreeze into the solution tank.
3. Turn the key to the on position (**without starting the machine**).
4. Press the *scrubbing main brush button*.
5. Press the *1-STEP button*.
6. Repeatedly press the *Solution increase button (+)* until the solution flow is at the highest setting.
7. Press the *directional pedal* to circulate the RV antifreeze completely through the system.
8. Press the *1-STEP button* to turn off the system.
9. **Machines equipped with the optional spray nozzle only:** Turn on the pump until RV antifreeze solution sprays from the nozzle.
10. Turn the key to the off position.
11. The remaining RV antifreeze does not need to be drained from the solution tank.

NOTE: Storing or transporting machines equipped with the ES or the FaST system in freezing temperatures requires special procedures. Consult a TENNANT representative for more information.

FREEZE PROTECTION (MACHINES WITH ec-H₂O SYSTEM)

FOR SAFETY: Before leaving or servicing machine, stop on level surface, set parking brake, and turn off machine.

1. Empty the solution tank and recovery tank.
2. Remove the intake flush hose and from the storage bag behind the operator seat.
3. Disconnect the *ec-H₂O* system intake hose from the solution supply hose and connect the intake flush hose (gray connector) to the *ec-H₂O* system intake hose.



4. Pull the drain tube from the between the ec-H₂O unit and the operator compartment, remove the cap from the tube, and place the end of the tube into an empty container. Set the cap aside.



5. Turn the key to the on position (**without starting the machine**).
6. Press and release the *ec-H2O* module flush switch. Allow the system to drain water into the container for 2 minutes.



7. Press the *ec-H2O* module flush switch to shut off the system.
8. Disconnect the *ec-H2O* system outlet hose from the hose to the scrub head.



9. Blow pressurized air (less than 344 kPa (50 psi)) into the *ec-H2O* system outlet hose. Continue blowing compressed air into the outlet hose until water no longer drains from the drain tube



10. Reinstall the cap onto the drain tube and insert the tube back between the *ec-H2O* module and the operator compartment.
11. Reconnect the *ec-H2O* system intake hose to the solution supply hose and the *ec-H2O* system outlet hose to the hose to the scrub head.
12. Return the intake flush hose to the storage bag behind the operator seat.

PRIMING THE *ec-H2O* SYSTEM

Prime the *ec-H2O* system if the machine has been stored for a long period without water in the solution tank / *ec-H2O* system.

FOR SAFETY: Before leaving or servicing machine, stop on level surface, set parking brake, and turn off machine.

1. Fill the solution tank with clean cool water.
See *FILLING THE SOLUTION TANK* section of this manual.
2. Remove the outlet flush hose (black connector) from the storage bag behind the operator seat.
3. Disconnect the *ec-H2O* system outlet hose from the hose to the scrub head and connect the outlet flush hose to the *ec-H2O* system outlet hose.



4. Place the *ec-H2O* system outlet hose into an empty container.
5. Turn the key to the on position (**without starting the machine**).
6. Press and release the *ec-H2O* module flush switch. Allow the system to drain water into the container for 2 minutes.
7. Press the *ec-H2O* module flush switch to shut off the system.
8. Disconnect the outlet flush hose from the *ec-H2O* system outlet hose and return the flush hose to the storage bag.
9. Reconnect the *ec-H2O* system outlet hose to the hose to the scrub head.

TROUBLESHOOTING

M20/M30 MEMBRANE PANEL SERVICE MODES

SERVICE MODE

The Service Modes are designed for Service Technician use only. A qualified Service Technician can interface with the machine to configure the machine and to test specific components.

1. Hold the Right Arrow next to the display down and turn the key switch on. Continue to hold the Right Arrow down until you see the message 'Manual Mode'.

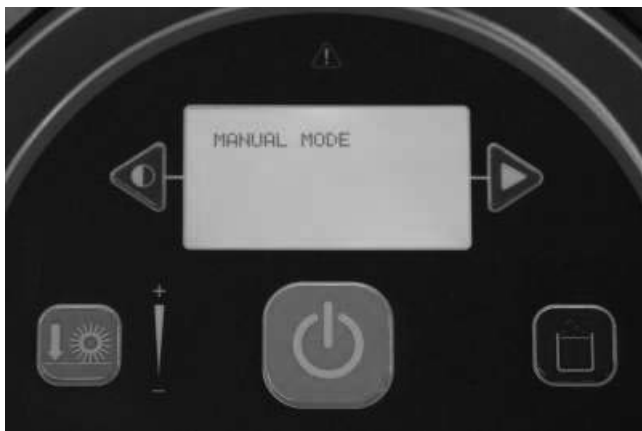

2. You can continue to press the right arrow until you see the mode you want to enter. The available modes are:
 - Manual Mode
 - Configure Mode
 - Self Test Mode
 - Input Display
 - Throttle Adjust
 - Down Pressure Adjust
 - Membrane Test

3. When you see the mode you want to enter, press the Orange Down Pressure Button to enter that mode.

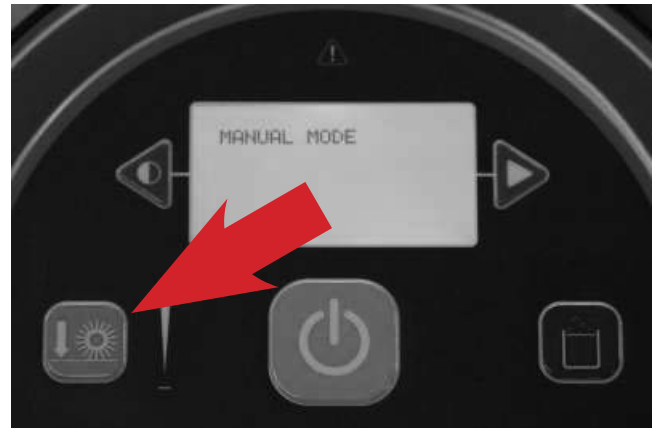

Note: The image below is the first message displayed when you enter the Manual Mode.



4. When the key switch is turned off, the machine will return to 'Normal Mode' when the key is turned on again.

TROUBLESHOOTING

M20/M30 PROPANEL SERVICE MODES

MANUAL MODE

1. Enter the Service Mode (See SERVICE MODE) and if needed, press the right arrow to scroll to the ,MANUAL MODE screen.
2. To enter the Manual Mode, press the 'Orange Down Pressure Button'.

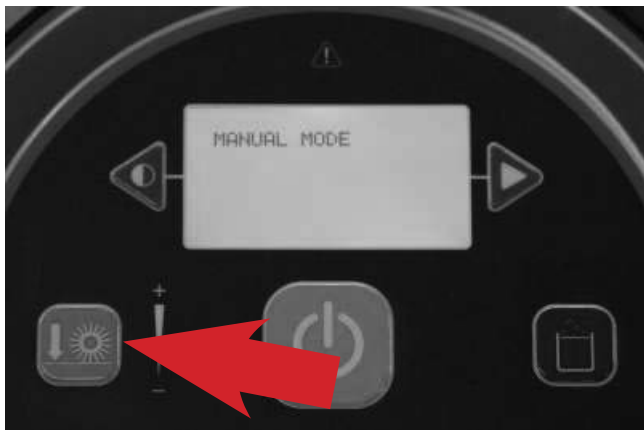

3. The first Component displayed in Manual Mode is the Hydraulic Enable Valve. It is turned off so there is 0000mA being delivered to the solenoid valve.

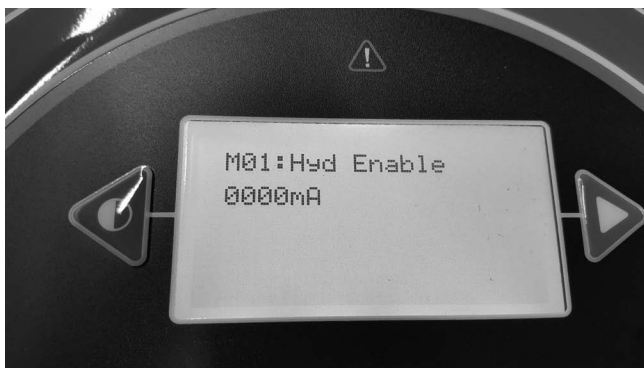

4. To turn on the Hydraulic Enable solenoid valve, press the Orange Down Pressure Button.



5. When a component is turn on, the amperage being output to that component, or the RPM of that component is displayed and testing can be done.

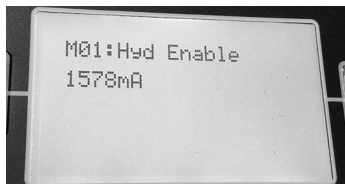

6. With the current component turned off, you can advance to another component by pressing the right arrow.
7. There are many components that can be turned on and off, so testing can be done.

M01: Hyd Enable = Hydraulic Enable
M02: MB Down Act = Main Brush Down Actuator
M03: MB ON Motor = Main Brush Motor ON
M04: MB DP PWM = Main Brush Down Pressure
M05: MB WaterVlv - Main Brush Water Valve
M06: SB Ext. Act = Side Brush Extend Actuator
M07: SB Down Act = Side Brush Down Actuator
M08: SB ON Motor = Side Brush Motor ON
M09: SB DP PWM = Side Brush Down Pressure
M10: SB WaterVlv = Side Brush Water Valve
M11: Water Vac = Water Vacuum
M12: Dust Vac = Dust Vacuum
M13: Squeegee Act = Squeegee Actuator
M14: Hopper Valve1 -= Hopper Valve 1
M14: Hopper Valve2 = Hopper Valve 2
M15: Hp Latch = Hopper Latch
M16: Hp Door = Hopper Door
M17: Shaker - Shaker
M18: Reverse = Reverse Sensor
M19: Shutdown = Shutdown Relay
M20: Alarm = Alarm
M21: Horn = Horn
M22: Det Pump = Detergent Pump
M23: Alt Pump = Alternate Pump
M24: AltHighFlow = Alternate High Flow
M25: AltSideBrush = Alternate Side Brush
M26: Sol AutoFill = Solution Auto Fill
M27: Rec AutoFill = Recovery Auto Fill
M28: Engine Speed = Engine RPM

Note: If a component is not installed on the machine, the message 'Not Installed' is displayed.

- To Exit Manual Mode, press the right arrow until you see 'Exit Manual Mode', then press the Orange Down Pressure Button **Twice**, or turn off the key switch.

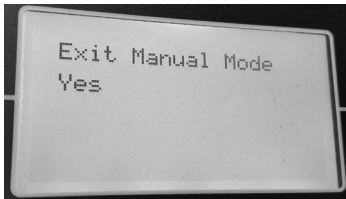

- Press the 'Orange Down Pressure Button' to allow changing the Alternate Solution setting.



CONFIGURATION MODE

Configuration Mode is an onboard diagnostic utility that configures controller software to operate optional equipment and to electronically adjust certain output functions.

- Enter the Service Mode (See SERVICE MODE) and press the right arrow to scroll to the CONFIG MODE screen.
- To enter the CONFIG MODE, press the Orange Down Pressure Button'.



- The C1: MainBrushHead choice feature is not used on the M20 / M30 machines, as only Cylindrical Scrub Heads are available on these models.
- Press the right arrow to scroll to the next configuration option, in this example we will explore setting the 'Alternate Solution Options'.

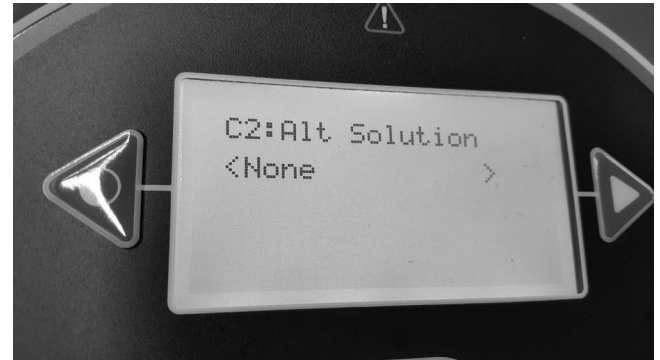
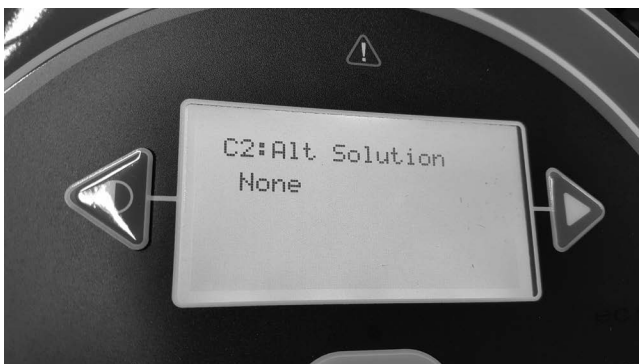

- Press the 'right arrow until the correct Alternate Solution' is displayed and press the Orange Down Pressure Button to accept the change.

The Alternate Solution Options are:

- None
- EcH₂O
- ES
- FaST

Choose the option that is installed on the machine.

- To configure other options on the machine, continuously press the right arrow to scroll to the desired configuration option and press the 'Orange Down Pressure Button' to choose that option and adjust the settings.

The configuration options are:

- C2: Alt Solution = Alternate Solution
- C5: Side Brush = Side Brush Type
- C6: Seat Switch = Seat Switch Installed?
- C7: Water Level = Solution Flow Rate
- C8 IRIS Module = IRIS Module Installed?
- C9: Run-In. Mode = End of Line Factory Use
- C10: Neut. Scrub = Neutral Scrub Enabled?

TROUBLESHOOTING

Additional Water Level Setting Information:

There are three water level range setting options.

- Economy
- Normal
- Heavy

When a settings is chosen, the operator can adjust three flow rate settings within that range.

8. After all of the 'Configuration' settings have been made. Press the right arrow until you see 'Exit Configuration Mode', then press the Orange Down Pressure Button **Twice**, or turn off the key switch.

SELF TEST MODE

Self Test Mode is an onboard diagnostic utility that tests for open or shorted output circuits. Once completed, open and/or shorted output faults, are displayed.

1. Enter the Service Mode (See SERVICE MODE) and press the right arrow to scroll to the SELF TEST MODE screen.
2. To enter the SELF TEST MODE, press the 'Orange Down Pressure Button'.



3. The self test will automatically begin.

CAUTION: Many of the machine functions will automatically turn on. Stay clear of the machine during the self test.

These are a few examples of the tests performed during the Self Test process. The table on the next page shows all of the test names and descriptions.

- Test Hydraulic Enable Valve
- Test Main Brush Down Actuator
- Test Main Brush Motor
- Test Main Brush PWM Valve
- Test Main Brush Water Valve

Some of the tests listed will only be performed if the machine has that specific option and it is configured correctly.

4. When the self test is completed, faults found will be displayed as an open or shorted load.
5. If faults exist, continually press the right arrow icon to display all faults found.

If there are no other faults found or no faults found initially, 'Self Test End' is displayed. Pressing the right arrow again will display any faults found again.

All successful tests performed will result in the message 'Done'. This indicates that test passed.

If a fault is found during the 'Self Test', either 'Open' or 'Short' will be displayed for that test.

"Open" (Indicates current could not be delivered to that circuit). There is an Open Load.

"Short" (The current draw is over the threshold, indicating a short circuit)

Follow the diagnostic steps in this manual for diagnosing an open or shorted circuit.

To exit the self test mode, turn off the machine key. The machine will return to normal operational mode when the key switch is turned on again.

Self Test Name:	Test Description:
1:Enable Valve	Test the valve which enables machine hydraulics.
2:MBrush Down Actuator	Tests the valve which controls 'Main Brush Down' actuation.
3:MBrush Motor...	Tests the valve which controls the Main Brush motor
4:MBrush PWM Valve	Tests PWM control of the Main Brush Down valve (for down pressure control).
5:MBrush Water Valve	Tests the valve which controls solution delivery to the Main Brush.
6:SBrush Down Actuator	Tests the valve which controls 'Side Brush Down' actuation.
7:SBrush Ext Actuator	Tests the valve which controls 'Side brush Extension' actuation.
8:SBrush Motor...	Test the valve which controls the Side Brush motor.
9:SBrush PWM Valve	Tests PWM control of the Side Brush Down valve (for down pressure control).
10:SBrush Water Valve	Tests the valve which controls solution delivery to the Side Brush
11:Scrub Vacuum Fan	Tests the vacuum fan for the scrub subsystem ('water pickup fan).
12:Sweep Vacuum Fan	Tests the vacuum fan for the sweep subsystem.
13: Squeegee Actuator	Tests the valve which controls the Squeegee Actuator.
14: SolTnk AF	Tests the Autofill valve for the Solution Tank. (If Configured)
15:RecTnk AF	Tests the Autofill valve for the Recovery Tank. (If Configured)
16:Reverse Relay	Tests the relay for reverse driving.
17:Shaker Relay	Tests the relay for the filter shaker.
18:Horn	Horn test.
19:Alarm	Backup alarm test.
20:Hopper Door Actuator	Tests the valve which controls the hopper door actuator.
21:Hopper Latch...	Tests the hopper latch.
22:Hopper Up Valve	Tests the valve which controls raising of the hopper.
23:Hopper Down Valve	Tests the valve which controls lowering of the hopper.
24:Detergent Pump	Tests the detergent pump.
25:Alt Pump	Tests the Alternative Solution pump (FAST). (If Configured)
26:Alt High Flow	Tests the High Flow Rate function of FAST. (If Configured)
27:Alt Side Brush	Tests the valve which controls alternative solution (FAST/ECH2O) to the Side Brush. (If Configured)
28:Shutdown Relay	Tests the emergency engine shutdown relay.

TROUBLESHOOTING

INPUT DISPLAY MODE

Input Display Mode is an onboard diagnostic utility that displays controller input conditions. Input Display Mode displays text messages for hard-wired switch, sensor, and touch panel button inputs.

1. Enter the Service Mode (See SERVICE MODE) and press the right arrow to scroll to the INPUT DISPLAY MODE screen.
2. To enter the INPUT DISPLAY MODE, press the 'Orange Down Pressure Button'.



3. The display will indicate the switch or sensor being tested. When the position of the switch or the state of the sensor is changed, the results of that change is displayed.

The components that can be tested with Input Display Mode Include:

- I1: SolTnk Empty
- I2: SolTnk Full
- I3: RecTnk Full
- I4: RedTank 1/2Full
- I5: Clogged HpFlt
- I6: CloggedHydFlt
- I7: ThermalSentry
- I8: Seat Switch
- I9: Brake Switch
- I10: HighEngTemp
- I11: Low Oil Psr
- I12: Check Engine
- I13: Ech2o Green
- I14: Ech2o Red
- I15: Hp Position
- I16: FilterShaker
- I17: Hp Up Rocker
- I18: HPDownRocker
- I19: HpDoor Open
- I20: HPDoor Close
- I21: Alternator
- I22: Throttle
- I23: Fuel Sender
- I24: Hyd Temp

4. To Exit the Input Display Mode, press the right arrow until you see 'Exit Input Display Mode', then press the Orange Down Pressure Button **Twice**, or turn off the key switch.

THROTTLE ADJUST MODE

1. Enter the Service Mode (See SERVICE MODE) and press the right arrow to scroll to the THROTTLE ADJUST MODE screen.
2. To enter the THROTTLE ADJUST MODE, press the 'Orange Down Pressure Button'.



3. The actual 'Neutral Voltage' value of the throttle position sensor is displayed. Pressing the 'Orange Down Pressure Button' sets the Forward and Reverse sense voltage values, based on this Neutral Voltage value. The machine operation should be tested to confirm the rear squeegee raises and lowers at the proper times when the machine is propelled forward and backward.

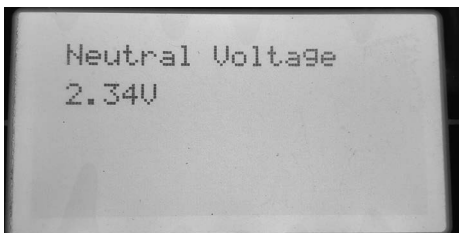

4. If the rear squeegee raises and lowers too soon or too late, you will need to adjust the Forward voltage value and/or the Reverse voltage value. Press the right arrow to proceed to the Forward Threshold voltage value.

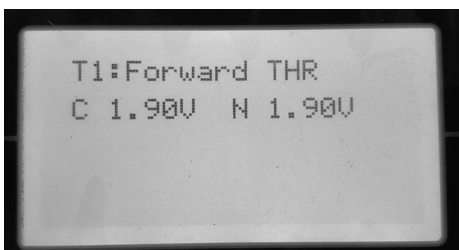

Note: the 'C' indicates the Current voltage value and the 'N' indicates the New voltage value you are setting.

5. Press the 'minus' icon to reduce the N (New) value and the 'Positive' icon to increase the N value.

The higher the Forward THR value, the quicker the system will react to forward direction movement. Press the Orange Down Pressure Button' to make your 'N' New value the 'C' Current value.



6. Press the right arrow to proceed to the Reverse Threshold voltage value.

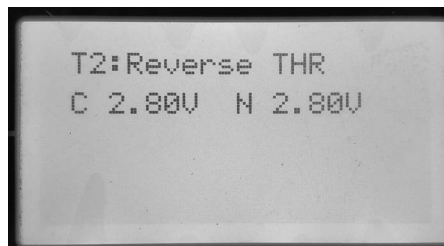
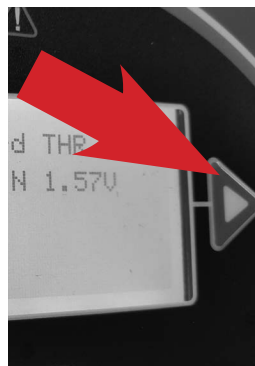

7. If the Reverse Threshold requires adjustment press either the 'minus' icon to reduce the N voltage or the 'plus' icon to increase the N voltage.

The higher the value, the quicker the system will react to reverse direction movement. Once the desired setting is achieved, press the 'Check Mark' to accept the change and confirm proper machine operation.



8. To Exit the Throttle Adjust Mode, press the right arrow until you see 'Exit Throttle Adjust Mode', then press the Orange Down Pressure Button **Twice**, or turn off the key switch.

TROUBLESHOOTING

DOWN PRESSURE ADJUST MODE

1. Enter the Service Mode (See SERVICE MODE) and press the right arrow to scroll to the DOWN PRESSURE ADJUST MODE screen.
2. To enter the DOWN PRESSURE ADJUST MODE, press the 'Orange Down Pressure Button'.

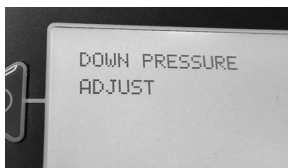

3. To enter the DOWN PRESSURE ADJUST MODE for the Main Scrub Brushes, press the 'Orange Down Pressure Button', again.

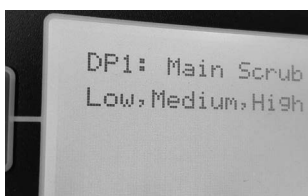

4. To enter the 'L' (Low Down Pressure Setting Mode) for the Main Scrub Brushes, press the 'Orange Down Pressure Button', again.

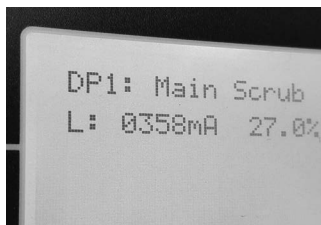
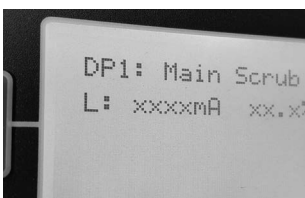

Note: With the setting numbers displayed for the Low main Scrub Brush Pressure adjustments can be made to that setting.

Note: The electrical signal transmitted to the control solenoid is measured in mA (milliamperes).

5. To increase the Low Setting Down Pressure for the Main Scrub Brushes, press the 'Plus' icon to increase the mA setting for the control valve. To decrease the pressure, press the 'Minus' icon to decrease the mA setting for the control valve. Each time an icon is pressed, the electrical signal to the solenoid is changed.



6. To allow adjustment to the Medium down pressure setting, press the 'Orange Down Pressure Button' to move backwards, then the 'Right Arrow' to move to the M: (Medium Down Pressure Setting) then press the 'Orange Down Pressure Button' to allow you to set the Medium down pressure setting, if desired.
7. To allow adjustment to the High down pressure setting, press the 'Orange Down Pressure Button' to move backwards, then the 'Right Arrow' to move to the H: (Heavy Down Pressure Setting) then press the 'Orange Down Pressure Button' to allow you to set the Heavy down pressure setting, if desired.
8. When all down pressure adjustments are completed for the Main Scrub Brushes, press the 'Orange Down Pressure Button' to move backwards, then the 'Right Arrow' to move to the Main Scrub Exit.
9. Press the 'Orange Down Pressure Button' to Exit the Main Scrub Down Pressure Setting Mode.

10. Press the 'Right Arrow' button to move to the Side Scrub Brush Down Pressure Adjust Mode. Follow the same process as above to make adjustments to the Side Scrub Brush Down pressure, if desired. You can press the 'Right Arrow' button again to move to the Main Sweeping Brush Down Pressure Adjust Mode and again for the Side Sweeping Brush Down Pressure Adjust Mode.

Follow the same adjustment procedures outlined for the Main Scrub Brush Down Pressure Settings.

11. To exit the Down Pressure Adjust Modes, press the Right Arrow until you see Exit DP Adjust. Press the 'Orange Down Pressure Button' twice to exit this mode.
12. To exit the Service Modes, turn off the key switch and then turn it on again.

MEMBRANE TEST MODE

1. Enter the Service Mode (See SERVICE MODE) and press the right arrow to scroll to the MEMBRANE TEST MODE screen.
2. To enter the MEMBRANE TEST MODE, press the 'Orange Down Pressure Button'.

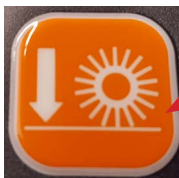
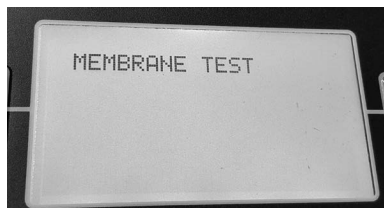

3. The MEMBRANE TEST MODE allows you to test the touch button functions, on the control panel. When you are in the Membrane Test Mode, you are directed to press each Membrane Button to test it's functionality.

NOTE: If you delay too long prior to pressing the required button, this delay may be reported with a 'Failed' message, in the display. If this happens, turn off the key switch and restart all testing procedures.

4. When you press a button as directed, if the button functions properly, you will be directed to press another button until all button tests are completed. If all of the tests were completed successfully, you will receive the message 'Passed' in the display window.

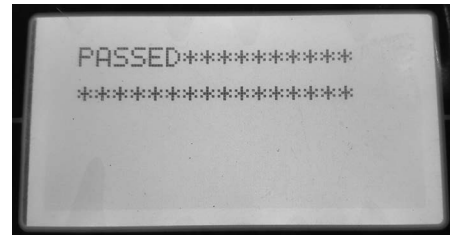

5. If a button fails to function as designed, you will receive the message 'FAILED' in the display window.



6. To exit the Service Modes, turn off the key switch and then turn it on again.

TROUBLESHOOTING

M20/M30 ProPanel Service Modes

SERVICE MODE

The Service Modes are designed for Service Technician use only. A qualified Service Technician can interface with the machine to configure the machine and to test specific components.

1. Key switch on. With the machine display powered on, press the 'Question Mark' Icon.



2. Press the Logout Icon and enter the Service Mode Login number and press the enter icon. (083957530)



3. Press the 'Gears' icon.



4. Using the down arrow, scroll to the bottom of the listed functions.



M20/M30 PROPANEL SERVICE MODES

1. Enter the Service Mode (See SERVICE MODE) and press the right arrow to scroll to the ,MANUAL MODE screen.
2. To enter the Manual Mode, press the 'Check Mark'.

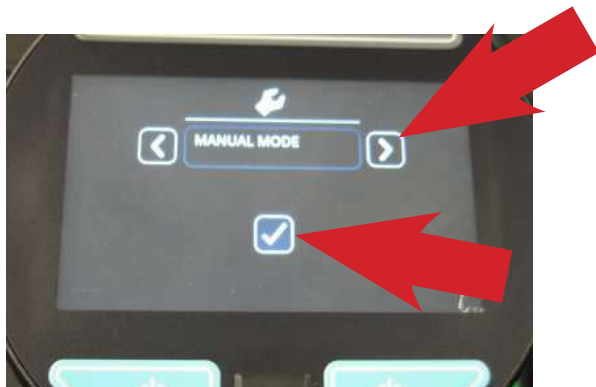

3. Manual Mode allows viewing many component amperage draws or RPM.

This includes:

- M01: Hyd Enable = Hydraulic Enable
- M02: MB Act = Main Brush Actuator
- M03: MB ON Motor = Main Brush Motor ON
- M04: MB DP PWM = Main Brush Down Pressure
- M05: MB WaterVlv - Main Brush Water Valve
- M06: SB Ext. Act = Side Brush Extend Actuator
- M07: SB Down Act = Side Brush Down Actuator
- M08: SB ON Motor = Side Brush Motor ON
- M09: SB DP PWM = Side Brush Down Pressure
- M10: SB WaterVlv = Side Brush Water Valve
- M11: Water Vac = Water Vacuum
- M12: Dust Vac = Dust Vacuum
- M13: Squeegee Act = Squeegee Actuator
- M14: Hopper Valve1 == Hopper Valve 1
- M14: Hopper Valve2 = Hopper Valve 2
- M15: Hp Latch = Hopper Latch
- M16: Hp Door = Hopper Door
- M17: Shaker - Shaker
- M18: Reverse = Reverse Sensor
- M19: Shutdown = Shutdown Relay
- M20: Alarm = Alarm
- M21: Horn = Horn
- M22: Det Pump = Detergent Pump
- M23: Alt Pump = Alternate Pump
- M24: AltHighFlow = Alternate High Flow
- M25: AltSideBrush = Alternate Side Brush
- M26: Sol AutoFill = Solution Auto Fill
- M27: Rec AutoFill = Recovery Auto Fill
- M28: Engine Speed = Engine RPM

Note: If a component is not installed on the machine, the message 'Not Installed' is displayed.

4. To activate a component, press the check mark. To deactivate a component, press the check mark again.

Note: When a component is active, the amperage output to that component or the RPM of that component is displayed.

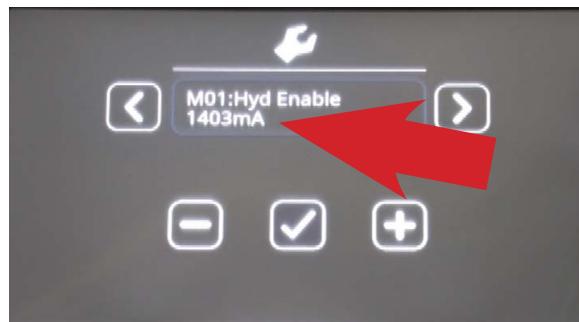

5. To exit Manual Mode, press the 'Check Mark' icon twice.

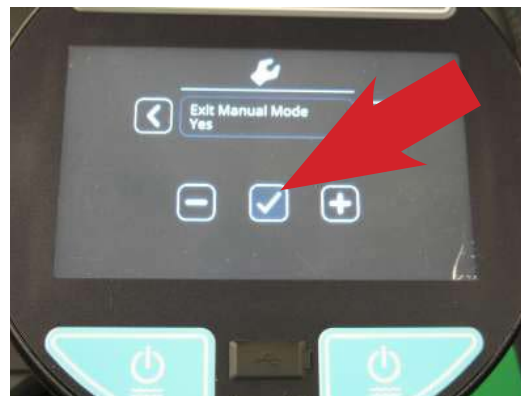

TROUBLESHOOTING

CONFIGURATION MODE

Configuration Mode is an onboard diagnostic utility that configures controller software to operate optional equipment and to electronically adjust certain output functions.

1. Enter the Service Mode (See SERVICE MODE) and press the right arrow to scroll to the CONFIG MODE screen.
2. To enter the CONFIG MODE, press the 'Check Mark' icon.



3. The C1: MainBrushHead choice feature is not used on the M20 / M30 machines.



4. Press the right arrow to scroll to the next configuration option and the 'Check Mark' icon to change settings.



5. Continuously press the right arrow to scroll to the desired configuration option and press the 'Check Mark' icon to choose a setting.



6. If no change is required, press the right arrow until you see the 'Exit' option and press the 'Check Mark' icon twice, to exit.



7. Follow the same procedure for other optional equipment and water flow rate setup.

Including:

- C1: Side Brush
- C6: Seat Switch
- C7: Water Level
- C8: IRIS Module

Additional Water Level Setting Information:

There are three water level range setting options.

- Economy
- Normal
- Heavy

When a settings is chosen, the operator can adjust three flow rate settings within that range.

TROUBLESHOOTING

SELF TEST MODE

Self Test Mode is an onboard diagnostic utility that tests for open or shorted output circuits. Once completed, open and/or shorted output faults, are displayed.

1. Enter the Service Mode (See SERVICE MODE) and press the right arrow to scroll to the SELF TEST MODE screen.
2. To enter the SELF TEST MODE, press the 'Check Mark' icon.



3. The self test will automatically begin.

CAUTION: Many of the machine functions will automatically turn on. Stay clear of the machine during the self test.

These are a few examples of the tests performed during the Self Test process. The table on the next page shows all of the test names and descriptions.

- Test Hydraulic Enable Valve
- Test Main Brush Down Actuator
- Test Main Brush Motor
- Test Main Brush PWM Valve
- Test Alternate Solution Pump

Some of the tests listed will only be performed if the machine has that specific option and it is configured correctly.

4. When the self test is completed, faults found will be displayed as an open or shorted load.
5. If faults exist, continually press the right arrow icon to display all faults found.

If there are no other faults found or no faults found initially, 'Self Test End' is displayed. Pressing the right arrow again will display any faults found again.



All successful tests performed will result in the message 'Done'. This indicates that test passed.

If a fault is found during the 'Self Test', either 'Open' or 'Short' will be displayed for that test.

"Open" (Indicates current could not be delivered to that circuit)

"Short" (The current draw is over the threshold, indicating a short circuit)

Follow the diagnostic steps in this manual for diagnosing an open or shorted circuit.

6. To exit the self test mode, turn off the machine key. The machine will return to normal operational mode when the key switch is turned on again.

Self Test Name:	Test Description:
1:Enable Valve	Test the valve which enables machine hydraulics.
2:MBrush Down	Tests the valve which controls 'Main Brush Down' actuation.
3:MBrush Motor	Tests the valve which controls the Main Brush motor
4:MBrush PWM	Tests PWMed control of the Main Brush Down valve (for down pressure control).
5:MBrush Water	Tests the valve which controls solution delivery to the Main Brush.
6:SBrush Down	Tests the valve which controls 'Side Brush Down' actuation.
7:SBrush Ext	Tests the valve which controls 'Side brush Extension' actuation.
8:SBrush Motor	Test the valve which controls the Side Brush motor.
9:SBrush PWM	Tests PWMed control of the Side Brush Down valve (for down pressure control).
10:SBrush Water	Tests the valve which controls solution delivery to the Side Brush
11:Scrub Vac Fan	Tests the vacuum fan for the scrub subsystem ('water pickup fan).
12:Sweep Vac Fan	Tests the vacuum fan for the sweep subsystem.
13: Squeegee Act	Tests the valve which controls the Squeegee Actuator.
14: SolTnk AF	Tests the Autofill valve for the Solution Tank.
15:RecTnk AF	Tests the Autofill valve for the Recovery Tank.
16:ReverseRelay	Tests the relay for reverse driving.
17:ShakerRelay	Tests the relay for the filter shaker.
18:Horn	Horn test.
19:Alarm	Backup alarm test.
20:Hopper Door	Tests the valve which controls the hopper door actuator.
21:Hopper Latch	Tests the hopper latch.
22:HopperUpVlv	Tests the valve which controls raising of the hopper.
23:HopperDownVlv	Tests the valve which controls lowering of the hopper.
24:DetergentPump	Tests the detergent pump.
25:AltPump	Tests the Alternative Solution pump (FAST).
26:AltHighFlow	Tests the High Flow Rate function of FAST.
27:AltSideBrush	Tests the valve which controls alternative solution (FAST/ECH2O) to the Side Brush.
28:ShutdownRelay	Tests the emergency engine shutdown relay.
29:ScrubControlA	Tests CAN communication to node A on the Main Board.
30:ScrubControlB	Tests CAN communication to node B on the Main Board.

TROUBLESHOOTING

INPUT DISPLAY MODE

Input Display Mode is an onboard diagnostic utility that displays controller input conditions. Input Display Mode displays text messages for hard-wired switch, sensor, and touch panel button inputs.

1. Enter the Service Mode (See SERVICE MODE) and press the right arrow to scroll to the INPUT DISPLAY MODE screen.
2. To enter the INPUT DISPLAY MODE, press the 'Checkmark' icon.



3. The display will indicate the switch or sensor being tested. When the position of the switch or the state of the sensor is changed, the results of that change is displayed.

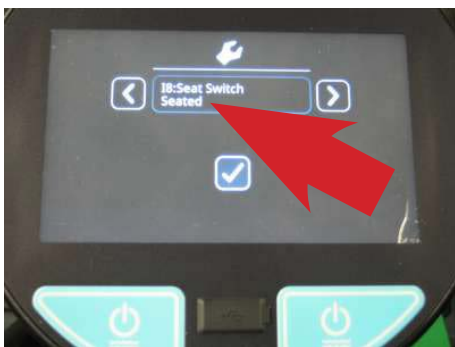

The components that can be tested with Input Display Mode Include:

- I1: SolTnk Empty
- I2: SolTnk Full
- I3: RecTnk Full
- I4: RedTank 1/2Full
- I5: Clogged HpFlt
- I6: CloggedHydFlt
- I7: ThermalSentry
- I8: Seat Switch
- I9: Brake Switch
- I10: HighEngTemp
- I11: Low Oil Psr
- I12: Check Engine
- I13: EcH2o Green
- I14: EcH2o Red
- I15: Hp Position
- I16: FilterShaker
- I17: Hp Up Rocker
- I18: HPDownRocker
- I19: HpDoor Open
- I20: HPDoor Close
- I21: Alternator
- I22: Throttle
- I23: Fuel Sender
- I24: Hyd Temp

THROTTLE ADJUST MODE

1. Enter the Service Mode (See SERVICE MODE) and press the right arrow to scroll to the THROTTLE ADJUST MODE screen.
2. To enter the THROTTLE ADJUST MODE, press the 'Check Mark' icon.

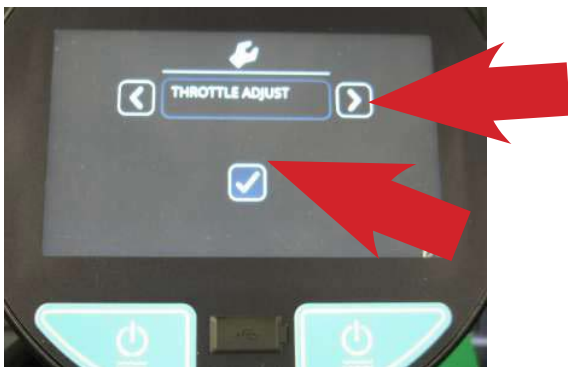

3. The actual 'Neutral Voltage' value of the throttle position sensor is displayed. Pressing the 'Check Mark' sets the Forward and Reverse sense voltage values, based on this Neutral Voltage value. The machine operation should be tested to confirm the rear squeegee raises and lowers at the proper times when the machine is propelled forward and backward.

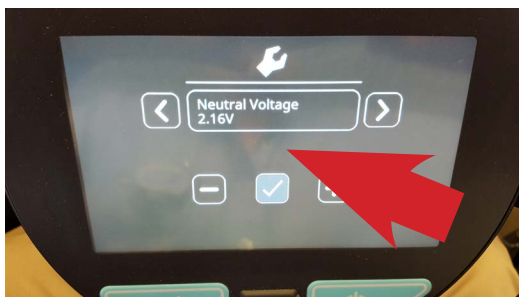

4. If the rear squeegee raises and lowers too soon or too late, you will need to adjust the Reverse voltage value and/or the Forward voltage value. Press the right arrow to proceed to the Forward Threshold voltage value.

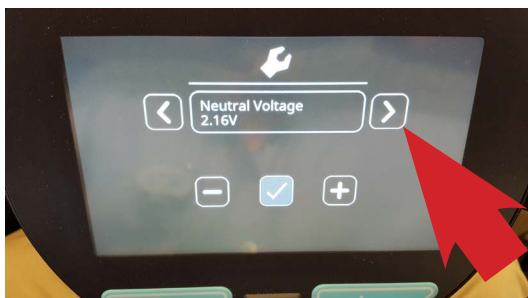

5. Note: the 'C' indicates the Current voltage value and the 'N' indicates the New voltage value you are setting.
6. Press the 'minus' icon to reduce the N (New) value and the 'Positive' icon to increase the N value.

The higher the value (a value closer to the Neutral Voltage value), the quicker the system will react to forward direction movement. Press the 'Check Mark' to make your 'N' New value the 'C' Current value.

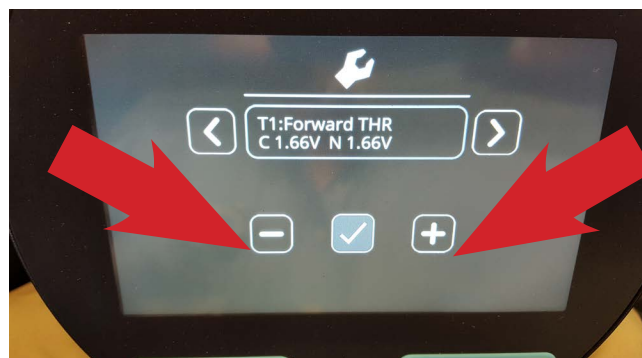

7. Press the right arrow to proceed to the Reverse Threshold voltage value.

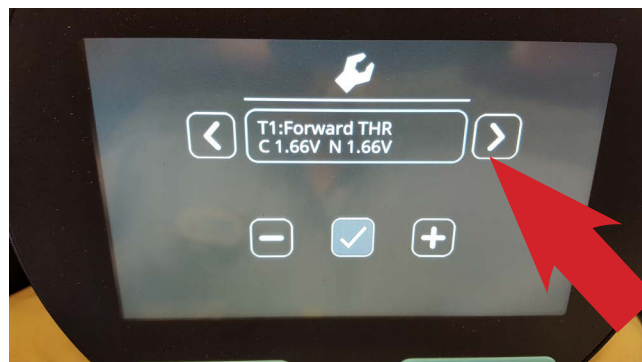

8. If the Reverse Threshold requires adjustment press either the 'minus' icon to reduce the N voltage or the 'plus' icon to increase the N voltage. The lower the value (a value closer to the Neutral Voltage value), the quicker the system will react to reverse direction movement. Once the desired setting is achieved, press the 'Check Mark' to accept the change and confirm proper machine operation.

TROUBLESHOOTING

DOWN PRESSURE ADJUST MODE

1. Enter the Service Mode (See SERVICE MODE) and press the right arrow to scroll to the DOWN PRESSURE ADJUST MODE screen.
2. To enter the DOWN PRESSURE ADJUST MODE, press the 'Check Mark' icon.

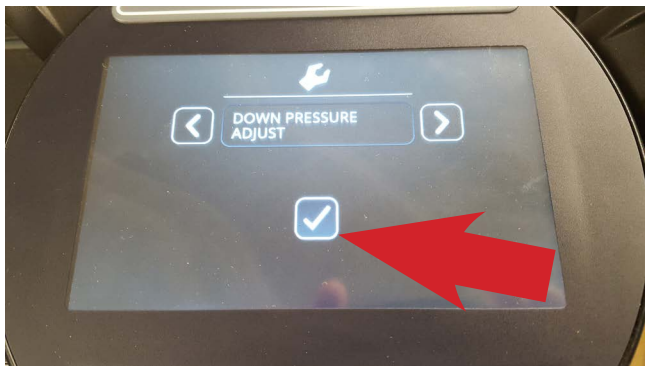

3. To enter the DOWN PRESSURE ADJUST MODE for the Main Scrub Brushes, press the 'Check Mark' icon.

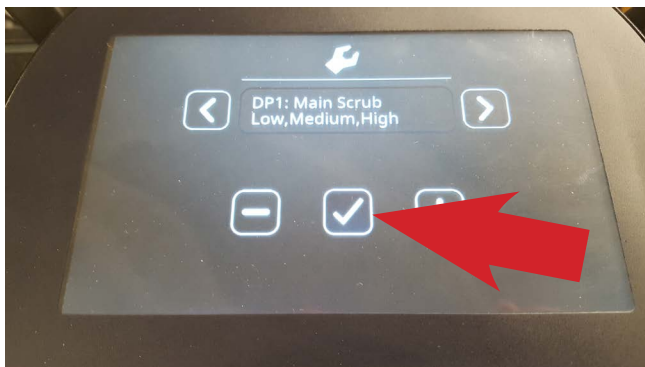

4. To enter the 'L' (Low Down Pressure Setting Mode) for the Main Scrub Brushes, press the 'Check Mark' icon.

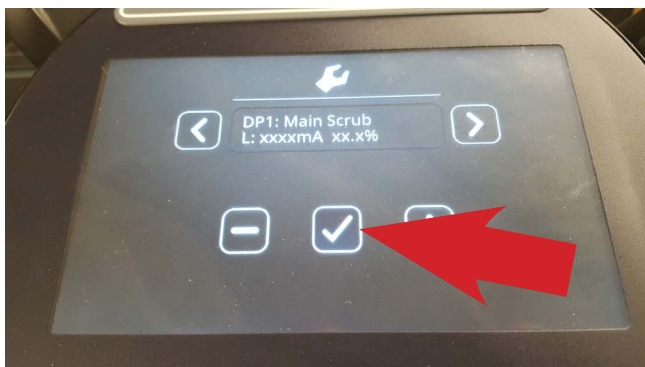

5. To increase the Low Setting Down Pressure for the Main Scrub Brushes, press the 'Plus' icon to increase the mA setting for the control valve. To decrease the pressure, press the 'Minus' icon to decrease the mA setting for the control valve. Each time an icon is pressed, the electrical signal to the solenoid is changed. This electrical signal is measured in mA (milliamperes).

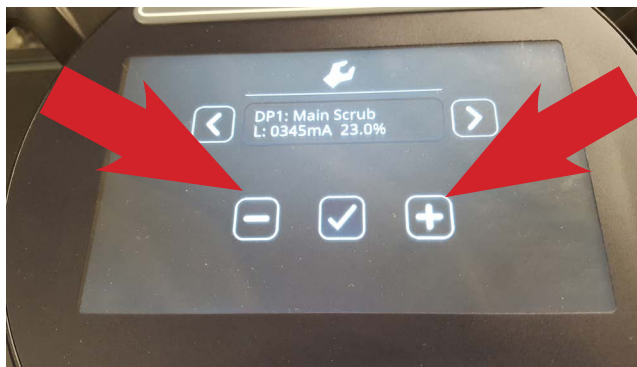

6. Press the 'Check Mark' icon to move backwards, then the 'Right Arrow' to move to the M: (Medium Down Pressure Setting) then press the 'Check Mark' to allow you to set the Medium down pressure setting, if desired.
 7. Press the 'Check Mark' icon to move backwards, then the 'Right Arrow' to move to the H: (High Down Pressure Setting) then press the 'Check Mark' to allow you to set the High down pressure setting, if desired.
 8. Press the 'Check Mark' icon to move backwards, then the 'Right Arrow' to move to Main Scrub Exit.
 9. Press the 'Check Mark' icon to Exit the Main Scrub Down Pressure Setting Mode.
 10. Press the 'Right Arrow' icon to move to the Side Scrub Brush Down Pressure Adjust Mode. Follow the same process as above to make adjustments to the Side Scrub Brush Down pressure, if desired. You can press the 'Right Arrow' icon again to move to the Main Sweeping Brush Down Pressure Adjust Mode and again for the Side Sweeping Brush Down Pressure Adjust Mode.
- Follow the same adjustment procedures outlined for the Main Scrub Brush Down Pressure Settings.

NOTE: Refer to the 'Default Down Pressure List' below, for the factory default down pressure settings.

DEFAULT DOWN PRESSURE LIST

Note: There is a low limit of 100mA and a high limit of 950mA for each brush pressure setting.

Main Scrub Brushes:

- Disk Low Pressure Default Setting, 358mA.
- Disk Medium Pressure Default Setting, 458mA.
- Disk High Pressure Default Setting, 548mA.
- Cyl. Low Pressure Default Setting, 340mA.
- Cyl. Medium Pressure Default Setting, 440mA.
- Cyl. High Pressure Default Setting, 530mA.

Main Sweep Brushes:

- Cyl. Low Pressure Default Setting, 250mA.
- Cyl. Medium Pressure Default Setting, 310mA.
- Cyl. High Pressure Default Setting, 350mA.

Side Scrub Brush:

- Low Pressure Default Setting, 600mA.
- Medium Pressure Default Setting, 675mA.
- High Pressure Default Setting, 730mA.

Side Sweep Brush:

- Low Pressure Default Setting, 570mA.
- Medium Pressure Default Setting, 570mA.
- High Pressure Default Setting, 570mA.

- To exit the Down Pressure Adjust Modes, press the Right Arrow until you see Exit DP Adjust. Press the 'Check Mark' two times to exit this mode.
- To exit the Service Modes, turn off the key switch and then turn it on again.

MEMBRANE TEST MODE

- Enter the Service Mode (See SERVICE MODE) and press the right arrow to scroll to the MEMBRANE TEST MODE screen.
- To enter the MEMBRANE TEST MODE, press the 'Check Mark' icon.

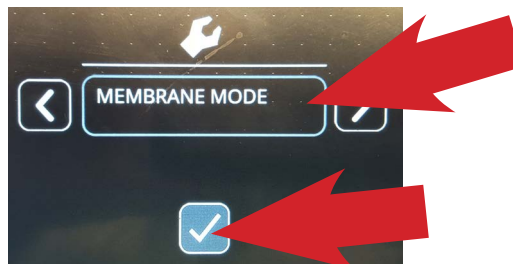

- The MEMBRANE TEST MODE allows you to test the touch button functions, on the control panel. When you are in the Membrane Test Mode, you are directed to press each Membrane Button to test it's functionality.

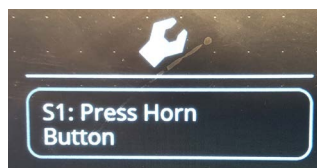

- When you press a button as directed, if the button functions properly, you will be directed to press another button.

Note: If you delay pressing the requested button too long, you may see a 'FAILED' message displayed. If this happens, restart the testing procedures.

If a button fails to function as designed, you will receive the message 'FAILED' in the display window.

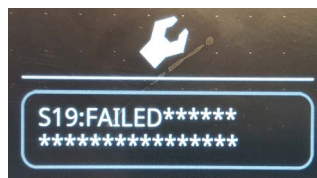

- To exit the Service Modes, turn off the key switch and then turn it on again.

