

# AquaPro™ XP

---

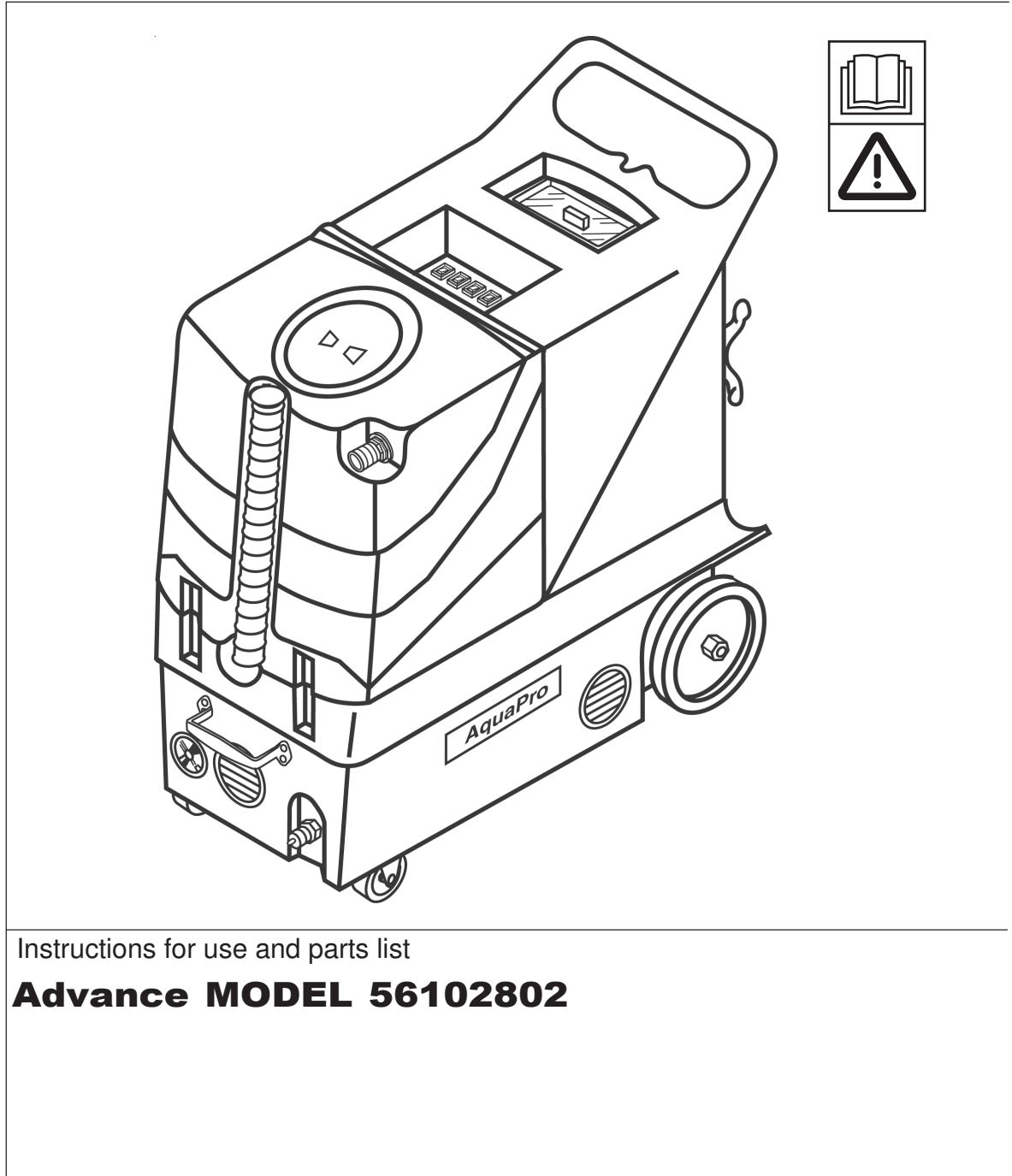

Instructions for use and parts list

**Advance MODEL 56102802**



**Advance**  
*by Nilfisk-Advance*

## INTRODUCTION

This manual will help you get the most from your **Advance AquaPro™ XP**. Read thoroughly before operating the machine.

**NOTE: Bold numbers in parenthesis indicate an item illustrated on page 7.**

This product is intended for commercial use only.

## PARTS AND SERVICE

Repairs, when required, should be performed by your authorized Advance Service Center, who employs factory-trained service personnel, and maintains an inventory of Advance original replacement parts and accessories.

Call the Advance DEALER named below for parts or service. Please specify the Model and Serial Number when discussing your machine.

(Dealer, affix service sticker here)

## NAME PLATE

The Model and Serial Number of your machine are shown on the nameplate in the machine. This information is needed when ordering repair parts for the machine. Use the space below to note the Model and Serial Number of your machine for future reference.

MODEL : \_\_\_\_\_

SERIAL NUMBER : \_\_\_\_\_

## UNCRATING

When the machine is delivered, carefully inspect the shipping carton and the machine for damage. If damage is evident, save the shipping carton so that it can be inspected. Contact Advance Customer Service Department immediately to file a freight damage claim.

## **DO NOT OPERATE THE MACHINE UNTIL YOU HAVE READ THIS SECTION. IMPROPER USE WILL VOID THE WARRANTY.**

- Always use a defoamer when foaming occurs to prevent vacuum motor damage.
- Never use water above 140° F (60°C).
- Do not store outdoors. Avoid extremes in temperature.
- Do not let the pump run dry. Turn the pump off and refill that tank when cleaning solution gets low.
- Use approved chemicals only. All chemicals should be mixed thoroughly. Liquid chemicals are recommended to prevent powder buildups. A pH between 6 and 9 is recommended. The use of high alkaline detergents or strong acids will accelerate the wear of the pump and seals, and will void the warranty.
- All extension cords must have a rating of at least 12/3 (#12 cord). Extension cords should be no longer than 50 feet. Replace the plug immediately if the ground prong becomes damaged or is broken off.

# IMPORTANT SAFETY INSTRUCTIONS

This machine is only suitable for commercial use, for example in hotels, schools, hospitals, factories, shops and offices other than normal residential housekeeping purposes.

When using an electrical appliance, basic precautions should always be followed, including the following:

Read all instructions before using this appliance.

## **WARNING!**

To reduce the risk of fire, electric shock, or injury:

- Do not leave the appliance when it is plugged in. Unplug the unit from the outlet when not in use and before servicing.
- To avoid electric shock, do not expose to rain. Store indoors.
- Do not allow to be used as a toy. Close attention is necessary when used near children.
- Use only as described in this manual. Use only the manufacturer's recommended attachments.
- Do not use with damaged cord or plug. If the appliance is not working as it should be, has been dropped, damaged, left outdoors or dropped into water, return it to a service center.
- Do not pull or carry by the cord, use the cord as a handle, close a door on the cord, or pull the cord around sharp edges or corners. Do not run the appliance over the cord. Keep the cord away from heated surfaces.
- Do not unplug by pulling on the cord. To unplug, grasp the plug, not the cord.
- Do not handle the plug, cord or appliance with wet hands.
- Do not put any object into openings. Do not use with any opening blocked; keep free of dust, lint, hair, and anything that may reduce air flow.
- Keep loose clothing, hair, fingers, and all parts of body away from openings and moving parts.
- Do not pick up anything that is burning or smoking, such as cigarettes, matches, or hot ashes, or any health endangering dusts.
- Turn off all controls before unplugging.
- Use extra care when cleaning on stairs.
- Do not use to pick up flammable or combustible liquids such as gasoline or use in areas where they may be present.
- Connect to a properly grounded outlet only. See Grounding Instructions.
- Liquid ejected at the spray nozzle could be dangerous as a result of its temperature, pressure or chemical content.

## **SAVE THESE INSTRUCTIONS**

# CONSIGNES DE SECURITE IMPORTANTES

Cette machine ne convient qu'à un usage industriel, par exemple dans des hôtels, écoles, hôpitaux, usines, boutiques et bureaux et autres à l'exclusion de tout usage de maintenance résidentielle normale.

L'utilisation d'un appareil électrique demande certaines précautions:

LIRE TOUTES LES INSTRUCTIONS AVANT DE FAIRE FONCTIONNER (CET APPAREIL)

## **AVERTISSEMENT!**

Pour réduire les risques d'incendie, de choc électrique ou de blessure:

- Ne pas laisser l'appareil sans surveillance lorsqu'il est branché. Débrancher lorsque l'appareil n'est pas utilisé et avant l'entretien.
- Pour réduire les risques de choc électrique, utiliser à l'intérieur seulement.
- Ne pas permettre aux enfants de jouer avec l'appareil. Une attention particulière est nécessaire lorsque l'appareil est utilisé par des enfants ou à proximité de ces derniers.
- N'utiliser que conformément à cette notice avec les accessoires recommandés par le fabricant.
- Ne pas utiliser si le cordon ou la fiche est endommagé. Retourner l'appareil à un atelier de réparation s'il ne fonctionne pas bien, s'il est tombé ou s'il a été endommagé, oublié à l'extérieur ou immergé.
- Ne pas tirer soulever ou traîner l'appareil par le cordon. Ne pas utiliser le cordon comme une poignée, le coincer dans l'embrasure d'une porte ou l'appuyer contre des arêtes vives ou des coins. Ne pas faire rouler l'appareil sur le cordon. Garder le cordon à l'écart des surfaces chaudes.
- Ne pas débrancher en tirant sur le cordon. Tirer plutôt la fiche.
- Ne pas toucher la fiche ou l'appareil lorsque vos mains sont humides.
- N'insérer aucun objet dans les ouvertures. Ne pas utiliser l'appareil lorsqu'une ouverture est bloquée. S'assurer que de la poussière, de la peluche, des cheveux ou d'autres matières ne réduisent pas le débit d'air.
- Maintenir les cheveux, les vêtements amples, les doigts et toutes les parties du corps à l'écart des ouvertures et des pièces mobiles.
- Ne pas aspirer de matières en combustion ou qui dégagent de la fumée, comme des cigarettes, des allumettes ou des cendres chaudes.
- Mettre toutes les commandes à la position ARRÊT avant de débrancher l'appareil.
- User de prudence lors du nettoyage des escaliers.
- Ne pas aspirer des liquides inflammables or combustibles, comme de l'essence, et ne pas faire fonctionner dans des endroits ou peuvent se trouver de tels liquides.
- Ne brancher qu'à une prise de courant avec mise à la terre. Voir les instructions visant la mise à la terre.
- Le liquide qui sort de l'embout de vaporisation peut s'avérer dangereux en raison de sa température, de sa pression ou du produit chimique qu'il contient.

**CONSERVER CES INSTRUCTIONS**

## 120VAC GROUNDING INSTRUCTIONS

This appliance must be grounded. If it should electrically malfunction, grounding provides a path of least resistance for electric current to reduce the risk of electric shock. This appliance is equipped with a cord having an equipment-grounding conductor and grounding plug. The plug must be plugged into an appropriate outlet that is properly installed and grounded in accordance with all local codes and ordinances.

### **DANGER!**

Improper connection of the equipment-grounding conductor can result in a risk of electric shock. Check with a qualified electrician or service person if you are in doubt as to whether the outlet is properly grounded. Do not modify the plug provided with the appliance. If it will not fit the outlet, have a proper outlet installed by a qualified electrician.

This appliance is for use on a nominal 120-volt circuit, and has a grounding plug that looks like the plug illustrated in Figure 1 below. A temporary adapter illustrated in Figures 2 and 3 may be used to connect this plug to a 2-pole receptacle as shown in Figure 2 if a properly grounded outlet is not available. The temporary adapter should be used only until a properly grounded outlet (Figure 1) can be installed by a qualified electrician. The green-colored rigid ear, tab, or the like extending from the adapter must be connected to a permanent ground such as a properly grounded outlet box cover. Whenever the adapter is used, it must be held in place by a metal screw. Grounding adapters are not approved for use in Canada.

Replace the plug if the grounding pin is damaged or broken.

The Green (or Green/Yellow) wire in the cord is the grounding wire. When replacing a plug, this wire must be attached to the grounding pin only.

Extension cords connected to this machine should be 12 gauge, three-wire cords with three-prong plugs and outlets. DO NOT use extension cords more than 50 feet (15 m) long.

#### PLEASE NOTE: FOR NORTH AMERICA ONLY

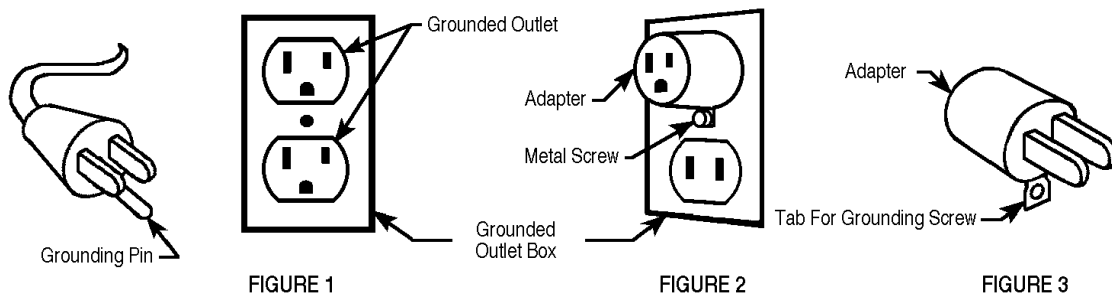

## INSTRUCTIONS VISANT LA MISE À LA TERRE (120VAC)

Cet appareil doit être mis à la terre. En cas de défaillance ou de panne éventuelles, la mise à la terre fournit au courant un chemin de moindre résistance qui réduit le risque de choc électrique. Cet appareil est pourvu d'un cordon muni d'un conducteur de terre et d'une fiche avec broche de terre. La fiche doit être branchée dans une prise appropriée correctement installée et mise à la terre conformément aux règlements et ordonnances municipaux.

### **⚠ AVERTISSEMENT !**

Un conducteur de terre mal raccordé peut entraîner un risque de choc électrique. Consulter un électricien ou un technicien d'entretien qualifié si vous n'êtes pas certain que la prise est correctement mise à la terre. Ne pas modifier la fiche fournie avec l'appareil - si elle ne peut être insérée dans la prise, faire installer une prise adéquate par un électricien qualifié.

Cet appareil est destiné à un circuit de 120 V et est muni d'une fiche de terre semblable à celle illustrée par le croquis 1. Un adaptateur temporaire semblable à celui illustré par le croquis 2 et C peut être utilisé pour brancher cette fiche à une prise bipolaire comme l'illustre le croquis 2 si une prise avec mise à la terre n'est pas disponible. L'adaptateur temporaire devrait être utilisé seulement jusqu'à ce qu'une prise avec mise à la terre soit installée par un électricien qualifié. L'oreille rigide ou le crochet ou autre dispositif semblable, de couleur verte, prolongeant l'adaptateur doit être raccordé à un élément correctement mis à la terre comme le couvercle d'une boîte de sortie mise à la terre. L'adaptateur doit être fixé par une vis métallique. Note: Au Canada, l'utilisation d'un adaptateur temporaire n'est pas autorisée par le Code canadien de l'électricité.

Remplacez la prise si la prise de terre est abîmée ou cassée.

Le fil Vert (ou Vert/Jaune) dans la ganse est le fil de terre. Lors du remplacement d'une prise, ce fil doit être raccordé à la prise de terre uniquement.

Les ralonges connectées à cette machine doivent avoir 12 mesures, trois ganses de fil ayant trois fiches masculines féminines tree-prong plugs and outlets. N'UTILISEZ PAS de ralonge de plus de 15 m (50 pieds) de long.

VEUILLEZ NOTER: CES INSTRUCTIONS CONCERNENT UNIQUEMENT L'AMÉRIQUE DU NORD

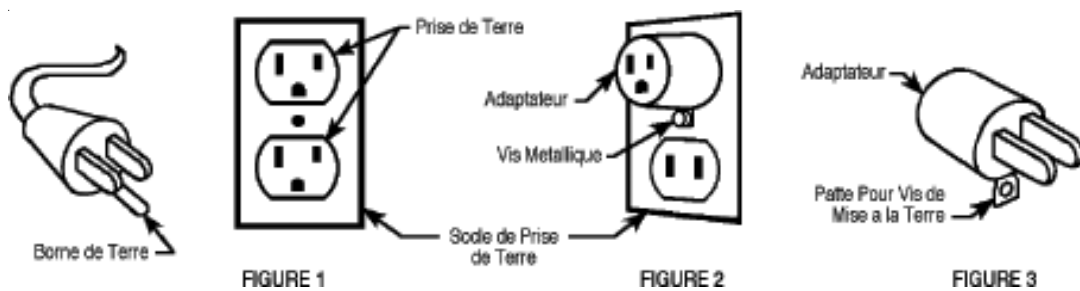

## KNOW YOUR MACHINE

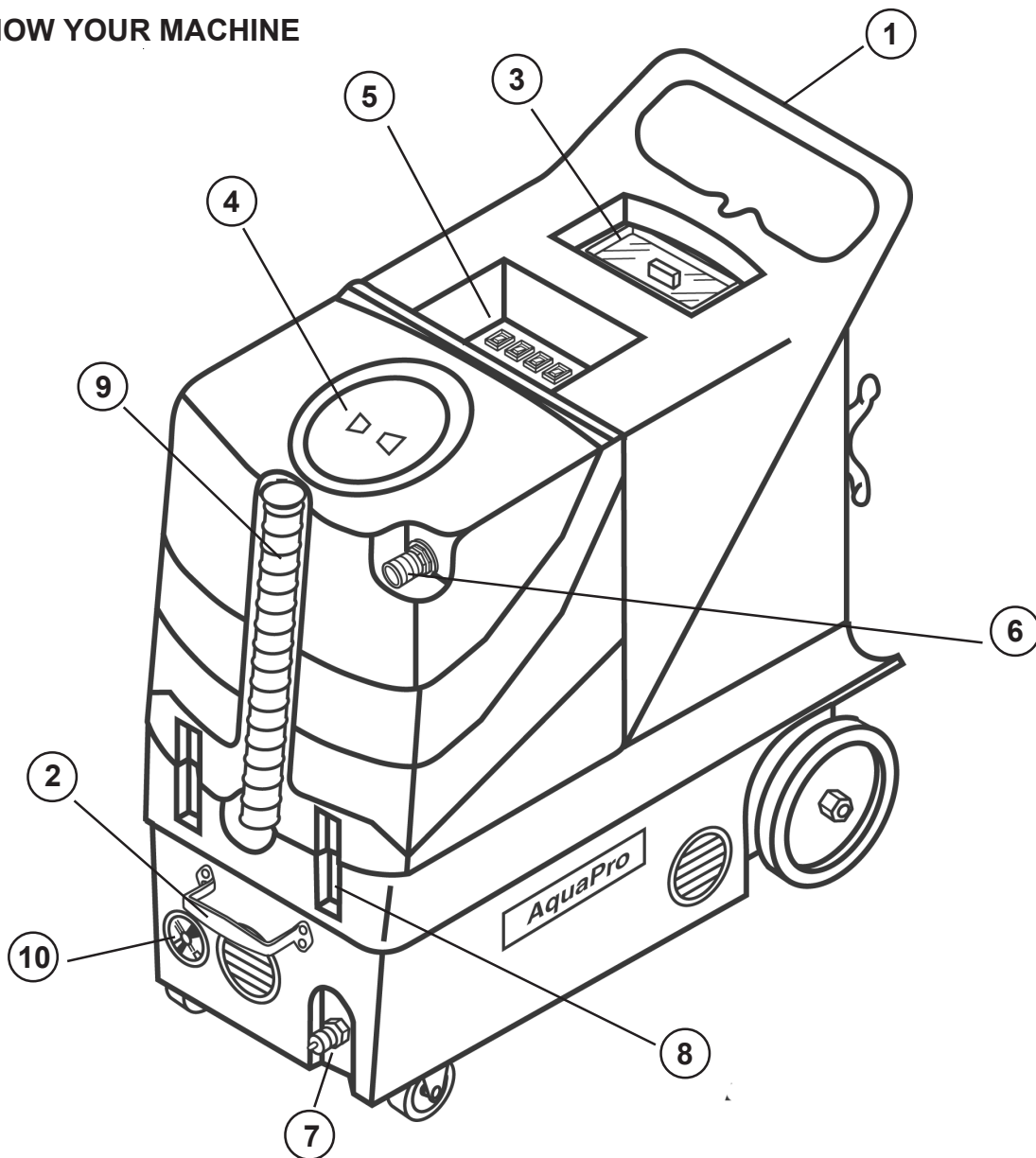

### KNOW YOUR MACHINE DESCRIPTIONS

**Operator Handle (1)** - Operator holds this to move the machine from one location to another.

**Lift Handle (2)** - Operator grasps this handle when lifting the machine.

**Solution Tank Lid (3)** - Fill Solution Tank here with warm water and chemicals.

**Recovery Tank Lid (4)** - The Recovery Tank can be flushed out by running clean water into this opening with the Recovery Tank Drain Hose open. The vacuum float Shut-OFF can also be accessed through this opening for maintenance.

**Switch Plate (5)** - The switches that operate the motors and the heater are located here, as well as indicator lights for the heater.

**Vacuum Hose Connector (6)** - This is where the vacuum hose attaches to the machine.

**Solution Hose Connector (7)** - This is where the solution hose attaches to the machine.

**Latches (8)** - These latches can be opened if the base compartment needs to be accessed. The latches are normally closed to keep the machine sections held together tightly.

**Drain Hose (9)** - This hose is used to empty the recovery tank of dirty water.

**Pressure Gauge (10)** - This gauge indicates the spraying pressure of the pump.

## SWITCH PLATE DESCRIPTIONS

**Locator Light (1)** - This green light will turn on when the two power cords are plugged into separate circuits. Separate circuits are defined as outlets fed by circuit breakers on opposite sides of the circuit breaker panel. This feature helps to prevent blown breakers. When the locator light (1) turns on, the heat exchanger will automatically turn on. If you can not get the locator light to turn on, use the Heat Switch (2) to turn the heat exchanger on.

**Heat Switch (2)** - This rocker switch turns the heat exchanger on and off, when the locator light (1) is not on. The switch will light when ON.

**Mode Light (3)** - This indicator light will turn on while the heat exchanger is actively heating. It will turn off when the heater has reached operating temperature. Normally, this light will be on most of the time as you do your job, but it may go out if you stop cleaning to move furniture or to empty or fill the tanks.

**Vacuum Switch (4)** - This switch turns the vacuum on and off. The switch will light when ON.

**Pump Switch (5)** - This switch turns the pump on and off. The switch will light when ON.

**Pressure Switch (6)** - This switch allows the operator to select the pump spraying pressure. Select Upholstery (top position) when low pressure is desired, and select carpet when high pressure is needed. This switch does not light up.

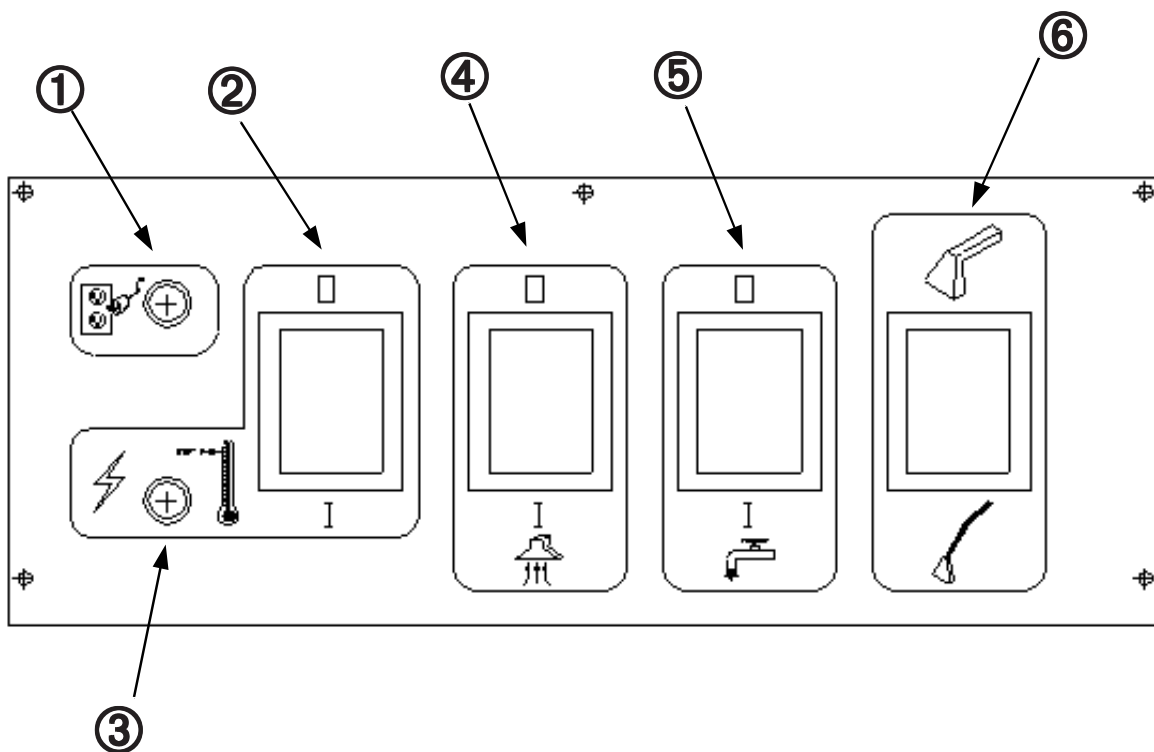



# WIRING DIAGRAM

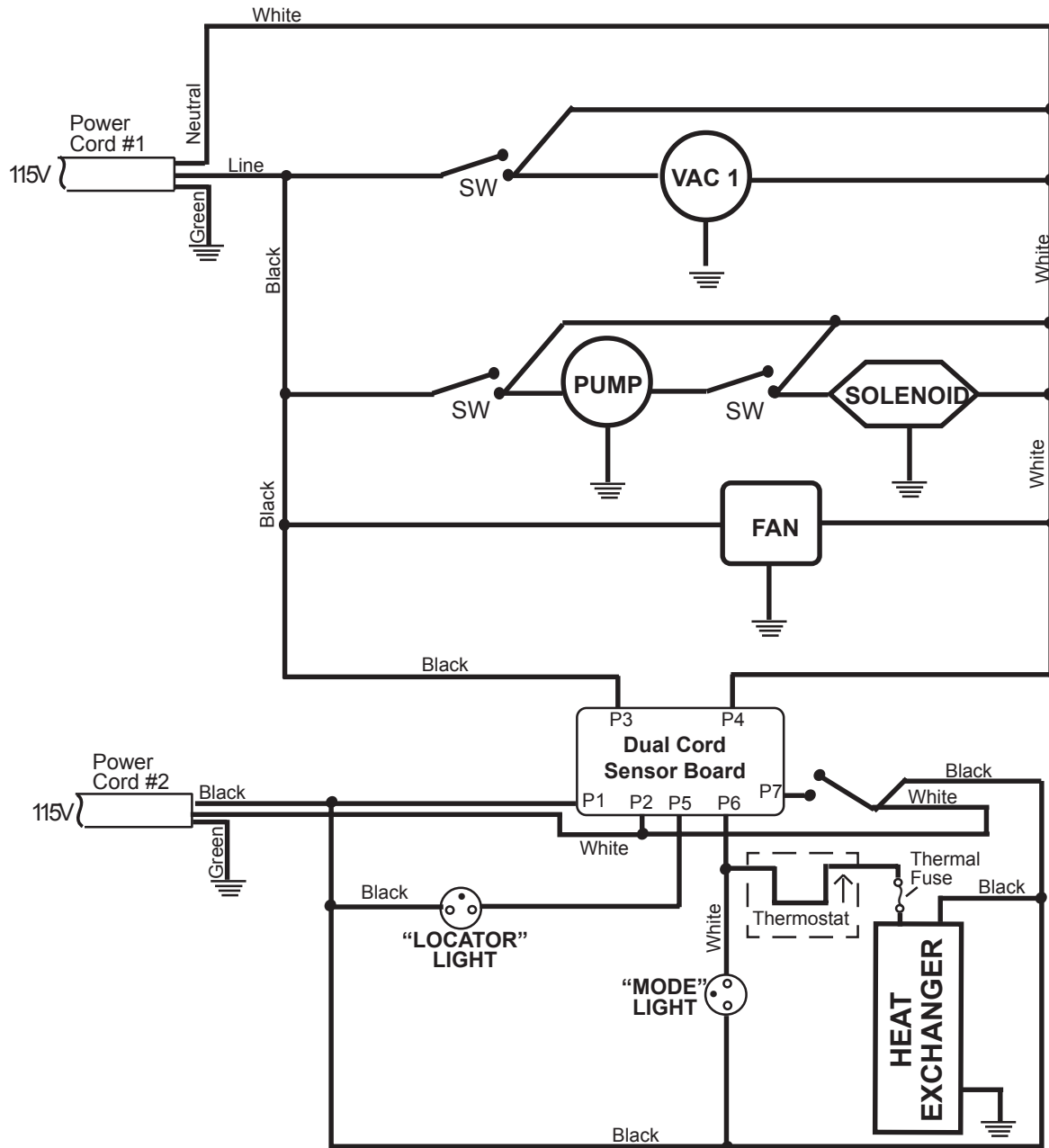

## OPERATION

- 1 Inspect the machine, hoses, and cleaning tools for cleanliness and completeness.
- 2 Fill the solution tank with water. Using warm water may be a benefit in cleaning effectiveness, but do not use hot water (above 140° F / 60°C) in the tank.
- 3 Plug in the power cords. Do not connect both cords to the same outlet; the circuit locator light on the switch plate should light up. If the locator light does not come on, try different outlets until it does. If you are certain the cords are on separate circuits, turn the heat switch on. **CAUTION:** using the heat switch when the cords are on the same circuit may cause the breaker to trip. **NOTE:** the cord with the red sleeve powers the heat exchanger.
- 4 Connect the priming hose to the machine, turn the pump on and prime the air out of the pump. When the water is clear (no air in it) turn the pump off and remove the priming hose. Priming may take 20 - 60 seconds.
- 5 Add liquid cleaning solution, with a pH of between 6 and 9, to the solution tank
- 6 Attach the spray hose to the solution quick disconnect and the vacuum hose to the hose barb on the recovery tank. Attach the other ends of the hoses to the cleaning tool.
- 7 Allow the heat exchanger two minutes to reach operating temperature.
- 8 Turn the pump on. Select carpet or upholstery. Turn the vacuum on.
- 9 Begin cleaning using the correct hoses and tool.
- 10 Use defoamer in the recovery tank any time foaming occurs.
- 11 Monitor water level in the solution tank. Do not let the pump run dry.
- 12 When the solution tank gets low, turn the pump and the vacuum off, fill the solution tank, empty and clean the recovery tank.
- 13 When finished with the job, remove any unused solution from the solution tank, and run a few gallons of clean water through the system.

## BALL FLOAT VACUUM SHUT-OFF

Prior to using the machine, always check that the float filter is clean and the ball can travel freely. When the recovery tank is full, the ball float will rise and will shut off the vacuum flow to prevent any more water from entering the tank. Turn off the vacuum, and empty the recovery tank.

**NOTE:** if foam is present, or if the ball float is prevented from rising, the float will not be able to stop the air flow, and the tank may over fill.



### **CAUTION!**

To avoid vacuum motor damage, always make sure the float filter is clean and the ball can travel freely prior to using the machine. And always use a defoamer when foaming occurs.

## ELECTRIC CIRCUIT LOCATOR

This unique, patented system is operated by a solid state circuit. It will inform the operator when the two cords are plugged into separate circuits by turning on the circuit locator light (see 1 on switch plate). This helps to prevent tripping circuit breakers.

**NOTE:** if the circuit locator light does not illuminate when the cords are plugged in, then both cords are on the same circuit. Try other outlets with one of the cords until you get the locator light to come on. **NOTE** if the heat switch (2 on switch plate) is turned on when both cords are on the same circuit, the breaker will trip.

## USE AND MAINTENANCE

- 1 Use only liquid chemicals with a pH between 6 and 9 at the recommended mix ratios. Improper chemicals, or improperly mixed chemicals, can cause possible damage to the pump, seals, and other components.
- 2 Turn the pump "off" when the solution tank is low on fluid. Do not let the pump run dry.
- 3 Regularly clean any mineral or chemical deposits in the heat exchanger, lines and pump with a mild acid descaler. Rinse the descaler out of the system with a few gallons of clear water.
- 4 Prior to each job, inspect, and clean if needed, the solution filter, the recovery tank float filter, and the drain hose.
- 5 Make sure the airways are not blocked before each use.
- 6 Inspect the carbon brushes on the vacuum motor once a year. Replace if worn down.
- 7 Clean the Recovery Tank daily. Clean the body and wheels as needed.
- 8 Keep the machine from extremes in temperatures.

MAINTENANCE SCHEDULE	Daily	Monthly	Yearly
FLUSH LINES & PUMP	X		
CLEAN VACUUM FLOAT FILTER	X		
CLEAN SOLUTION FILTER	X		
CHECK INLET AIRWAYS	X		
DESCALE MACHINE		X	
CHECK VACUUM MOTOR BRUSHES			X

## TECHNICAL SPECIFICATIONS

Vacuum Motor: One, 3-Stage  
 Water lift: 140"  
 Air Flow: 94 cfm  
 Amp Draw: 16 amps, each cord  
 Tank Construction: Rotationally molded polyethylene  
 Solution Tank Capacity: 14 Gal. (53.2 L)  
 Recovery Tank Capacity: 13 Gal.(49.4 L)  
 Application Flow: 300 psi / 60 psi  
 Solution Hose Length: 15 ft. (4.5 m)  
 Recovery Hose Length: 15 ft. (4.5 m)  
 Power Cord: Two 25 ft. (7.6 m), High visibility yellow, removable  
 Rear Wheels: 10 in. (25 cm)  
 Front Castors: 4 in. (10.2 cm)  
 Heat Exchanger: 2000 Watt  
 Height: 38 in (96.5 cm)  
 Length: 36 in (91.4 cm)  
 Width: 17.6 in (44.7 cm)  
 Machine weight: 115 lb (52 Kg)

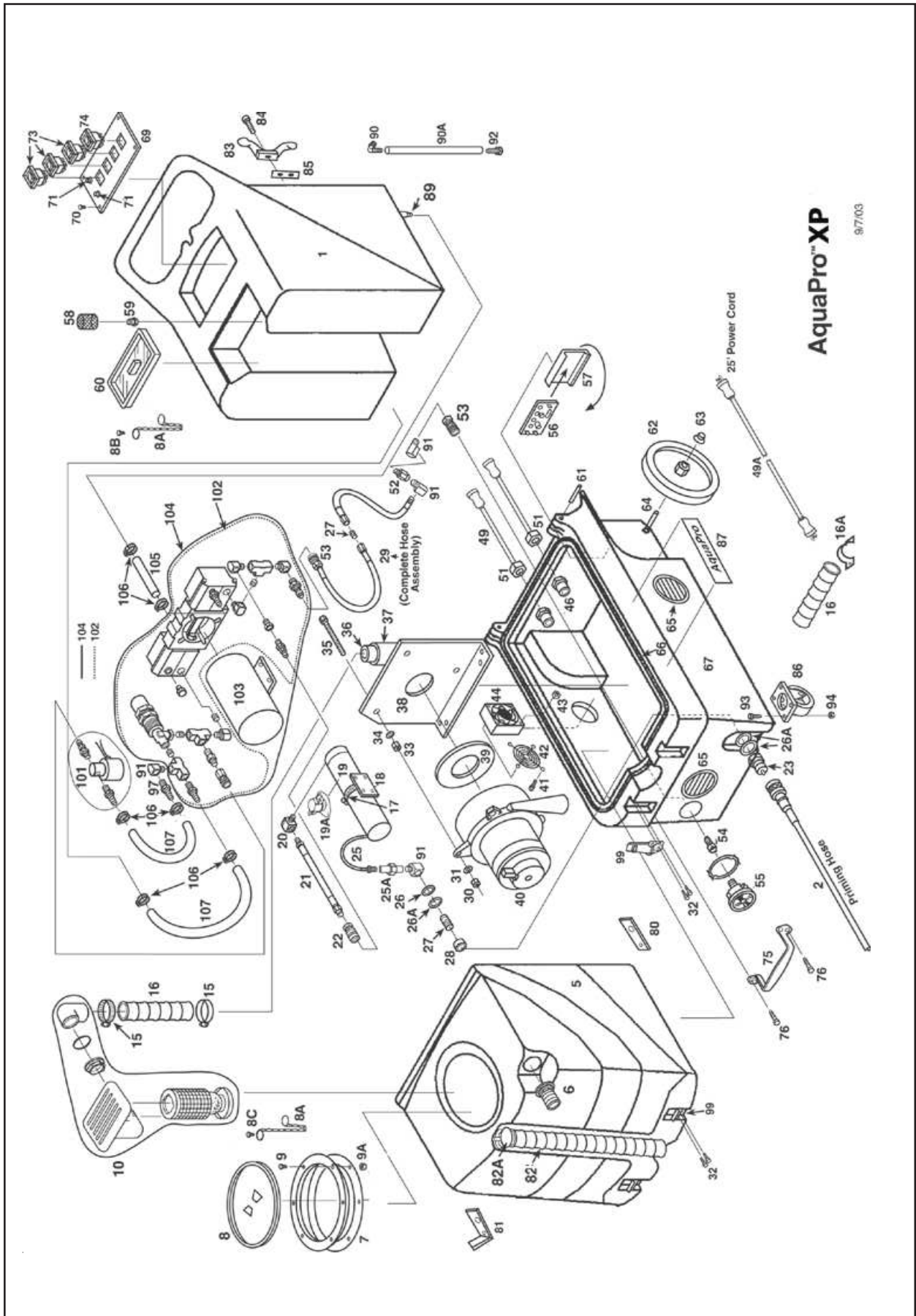

**AquaPro™ XP**

9/7/03

## PART LIST AquaPro™ XP

Item	Ref. No.	Qty	Description
1	56102809	1	Solution Tank, Light Gray
2	56108024	1	Priming Hose, 3/8" x 54"
5	56102808	1	Recovery Tank, Light Gray
6	56108061	1	Vac Inlet Hose Barb
7	56102823	1	Gasket ( <b>Hardware Kit</b> )
8	56108055	1	Lid, 6", Clear Center, W/Ring
8A	56108054	2	Chain, 8" ( <b>also included in Solution Lid Kit 56102812</b> )
8B	56102812	1	Screw, 10-32 x .38, Brass ( <b>Solution Lid Kit</b> )
8C	56102823	1	Screw, 10-32 x .62 ( <b>Hardware Kit</b> )
9	56102823	6	Screw, 8-32 x .88 ( <b>Hardware Kit</b> )
9A	56102823	6	Lock Nut, 8-32 ( <b>Hardware Kit</b> )
10	56108052	1	Float, Ball & Cage on Manifold
15	56102824	2	Hose Clamp ( <b>Hose Clamp Kit</b> )
16	56102841	1	Hose, Vacuum, 2" x 41"
16A	56102870	1	Bracket, Exhaust Hose
17	56102824	1	Hose Clamp ( <b>Hose Clamp Kit</b> )
18	56102869	1	Mount, Bracket, Heat Exchanger
19	56102826	1	Heat Exchanger, Complete ( <b>Heat Exchanger, Complete</b> )
19A	56102826	1	Heat Control Switch ( <b>Heat Exchanger, Complete</b> ) ( <b>also included in Heat Repair Kit 56102819</b> )
20	56102835	1	Elbow, Brass, 1/8 NPT ( <b>High Pressure Hose Kit</b> )
21	56102835	1	Hose, High Pressure, 26" ( <b>High Pressure Hose Kit</b> )
22	56102835	1	Quick Disconnect, 1/8 NPT ( <b>High Pressure Hose Kit</b> )
23	56102826	1	Quick Disconnect, 1/4 NPT ( <b>Heat Exchanger, Complete</b> ) ( <b>also included in Quick Disconnect Kit 56102813</b> )
25	56102826	1	Hose, Braided, SS ( <b>Heat Exchanger, Complete</b> )
25A	56102826	1	Coupling, Brass ( <b>Heat Exchanger, Complete</b> )
26	56102826	3	Washer, Brass ( <b>Heat Exchanger, Complete</b> )
26A	56102826	3	Washer, Fiber ( <b>Heat Exchanger, Complete</b> ) ( <b>also included in Quick Disconnect Kit 56102813</b> )
27	56102826	2	Nipple, SS 1/4 NPT ( <b>Heat Exchanger, Complete</b> ) ( <b>also included in Hose, Pump to Gauge, Complete 56102831</b> )
28	56102826	1	Bushing, Fiber ( <b>Heat Exchanger, Complete</b> )
29	56102831	1	Hose, Pump to Gauge, Complete (#27, 52, 53, 91)
30	56102823	3	Lock Nut, Jam, 5/16 ( <b>Hardware Kit</b> )
31	56102823	3	Washer, Flat, 5/16 ( <b>Hardware Kit</b> )
32	56102823	8	Screw, 8-32 x .50 ( <b>Hardware Kit</b> )
33	56102823	3	Nut, Finish, 5/16 ( <b>Hardware Kit</b> )
34	56102823	3	Washer, Split Lock, 5/16 ( <b>Hardware Kit</b> )
35	56102823	3	Bolt, 5/16 x 4.00, Fully Threaded ( <b>Hardware Kit</b> )
36	56102837	1	Pipe, PVC, 3" ( <b>PVC Pipe Kit</b> )
37	56102837	1	Elbow, PVC ( <b>PVC Pipe Kit</b> )
38	56102868	1	Manifold
39	56102821	1	Gasket, Vacuum Motor ( <b>Vac Motor Kit</b> )
40	56102821	1	Vacuum Motor, 120V ( <b>Vac Motor Kit</b> )
41	56102823	4	Screw, 6-32 x 2.00 ( <b>Hardware Kit</b> )
42	56108096	1	Fan Guard ( <b>Fan Kit</b> )
43	56102823	4	Lock Nut, 6-32 ( <b>Hardware Kit</b> )
44	56108096	1	Fan, 120V ( <b>Fan Kit</b> )
46	56102820	2	PVC Reducer ( <b>Cord Outlet Kit</b> )
49	56102820	2	Cord, Pigtail, 24", 12/3 ( <b>Cord Outlet Kit</b> )
49A	56102846	2	Cord, 25ft, 12/3
51	56102820	2	Cord Retainer ( <b>Cord Outlet Kit</b> )
52	56102831	1	Snubber, Pulsation ( <b>Hose, Pump to Gauge, Complete</b> )
53	56102831	2	Quick Disconnect, Female, 1/4 NPT ( <b>Hose, Pump to Gauge, Complete</b> )
54	56102864	1	Quick Disconnect, Male, 1/4 NPT ( <b>Pressure Gauge Kit</b> )
55	56102864	1	Pressure Gauge, 600 PSI ( <b>Pressure Gauge Kit</b> )
56	56102866	1	Dual Cord Sensor PCB
57	56102867	1	Snap Track, PCB Mount, 4" LG
58	56102853	1	Filter, Pump Inlet
59	56102854	1	Nipple, PVC, 1/2NPT
60	56102812	1	Lid, Solution Tank ( <b>Solution Lid Kit</b> )
61	56102850	2	Hinge Pin
62	56102811	2	Wheel, 10" ( <b>Wheel Kit</b> )
63	56102811	2	Axle Cap ( <b>Wheel Kit</b> )
64	56102847	1	Axle Rod, Plated, 18.25"
65	56102845	2	Louver, W/3 Screws Each
66	56102860	1	Gasket, 7ft
67#	56380436	1	Base Compartment, Gray ( <b>before SN1889390</b> ) TSBUS2008-995
#	56380434	1	Base Compartment, Gray ( <b>after SN1889391</b> ) TSBUS2008-995
69	56102859	1	Switch Plate



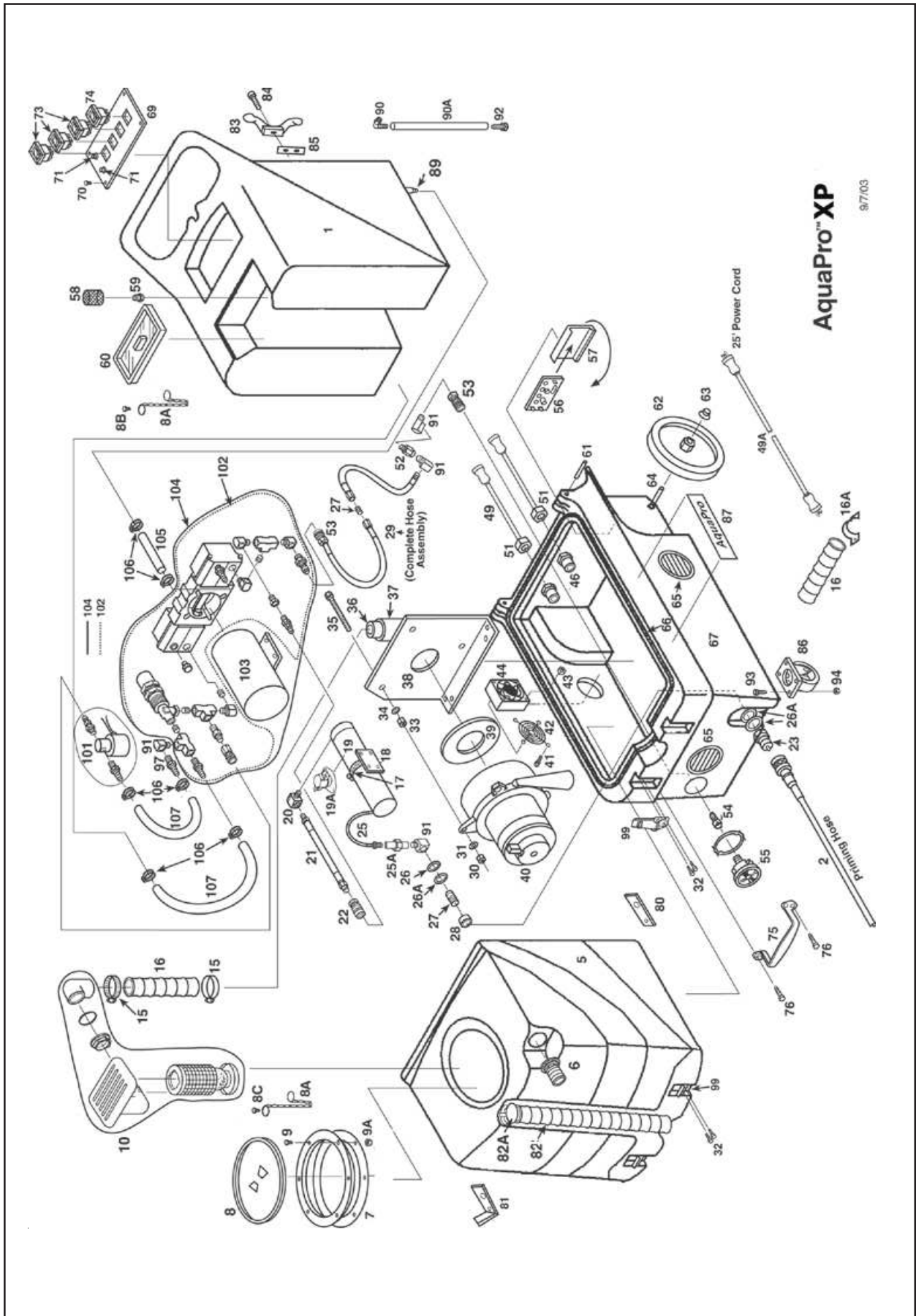

**AquaPro™ XP**  
9/7/03

## PART LIST AquaPro™ XP (continued)

Item	Ref. No.	Qty	Description
70	56102823	5	Screw, #4 x .38 <b>(Hardware Kit)</b>
71	56102863	2	Light, Green, 120V
73	56102827	3	Switch, SPST, W/Cover
74	56102828	1	Switch, DPDT, W/Cover
75	56102843	1	Handle, Chrome
76	56102823	4	Screw, 1/4-20 x .75, Flat Head <b>(Hardware Kit)</b>
80	56102815	1	Bracket, Mating <b>(Bracket Kit)</b>
81	56102815	1	Bracket, Mating <b>(Bracket Kit)</b>
82	56108071	1	Hose, Drain, 2" x 24" <b>(Dump Hose Kit)</b>
82A	56108071	1	Plug, Drain Hose <b>(Dump Hose Kit)</b>
83	56102856	2	Cord Wrap, Black
84	56102823	4	Screw, 1/4-20 x 1.00 <b>(Hardware Kit)</b>
85	56102815	2	Bracket, Caddy Bag <b>(Bracket Kit)</b>
86	56102848	2	Castor, 4", No Brake
87	56102840	2	Label, Advance AquaPro
89	56102852	1	Hose Barb, Nylon, Straight <b>(Hose Barb Kit)</b>
90	56108084	1	Hose Barb, Elbow, 1/2 <b>(Solution Hose Kit)</b>
90A	56108084	1	Hose, Site, 1/2" <b>(Solution Hose Kit)</b>
91	56102826	4	Elbow, Brass, 1/4 NPT <b>(Heat Exchanger, Complete)</b> <b>(also included in Hose, Pump to Gauge, Complete 56102831 &amp; Hose Barb Kit 56102852)</b>
92	56108084	1	Hose Barb, Straight, 1/2" <b>(Solution Hose Kit)</b>
93	56102823	8	Bolt, 1/4-20 x .75 <b>(Hardware Kit)</b>
94	56102823	8	Lock Nut, 1/4-20 <b>(Hardware Kit)</b>
97	56102852	1	Hose Barb, Brass <b>(Hose Barb Kit)</b>
99	56108074	2	Latch, Rubber, W/Strike
101	56102832	1	Solenoid, Complete, 120V
102	56102833	1	Pump Complete, No Motor
103	56108040	1	Motor, Pump, 120V
104	56102834	1	Pump & Motor Complete
105	56102838	1	Hose, 1/2" x 16"
106	56102824	6	Hose Clamp <b>(Hose Clamp Kit)</b>
107	56102839	1	Hose, 3/8" x 76"
*	56108093	1	Label, Warning

\* = Not Shown

### KITS

56108096	1	Fan Kit (#42, 44)
56102811	1	Wheel Kit (1 each of #62, 63)
56102812	1	Solution Lid Kit (#8B, 60 / also includes #8A)
56102823	1	Hardware Kit (#7, 8C-9A, 30-35, 41, 43, 70, 76, 84, 93, 94)
56102824	1	Hose Clamp Kit (#15, 17, 106)
56102821	1	Vacuum Motor Kit (1 each of #39, 40)
56102813	1	Quick Disconnect Kit (#23, 26A)
56102815	1	Bracket Kit (#80, 81, 85)
56102826	1	Heat Exchanger, Complete (#19, 19A, 23, 25-28, 91)
56102819	1	Heat Repair Kit (#19A)
56108071	1	Dump Hose Kit (#82, 82A)
56108084	1	Solution Hose Kit (#90, 90A, 92)
56102820	1	Cord Outlet Kit (1 each of #46, 49, 51)
56102852	1	Hose Barb Kit (#89, 97 / also includes #91)
56108090	1	Pump Rebuild Kit (Valves & O-Rings)
56108091	1	Pump Rebuild Kit (Plunger & Seals)
56102862	1	Bypass Rebuild Kit
56102831	1	Hose, Pump to Gauge, Complete (#52, 53 / also includes #27, 91)
56102864	1	Pressure Gauge Kit (#54, 55)
56102835	1	High Pressure Hose Kit (#20-22)
56102837	1	PVC Pipe Kit (#36, 37)

### ACCESSORIES

56102804	1	Single Bend Wand Assembly
56102805	1	Double Bend Wand Assembly
56102807	1	Extractor Hand Tool
56102861	1	Vac Hose / Pressure Line 25ft.
56102871	1	Vac Hose / Pressure Line 15ft.

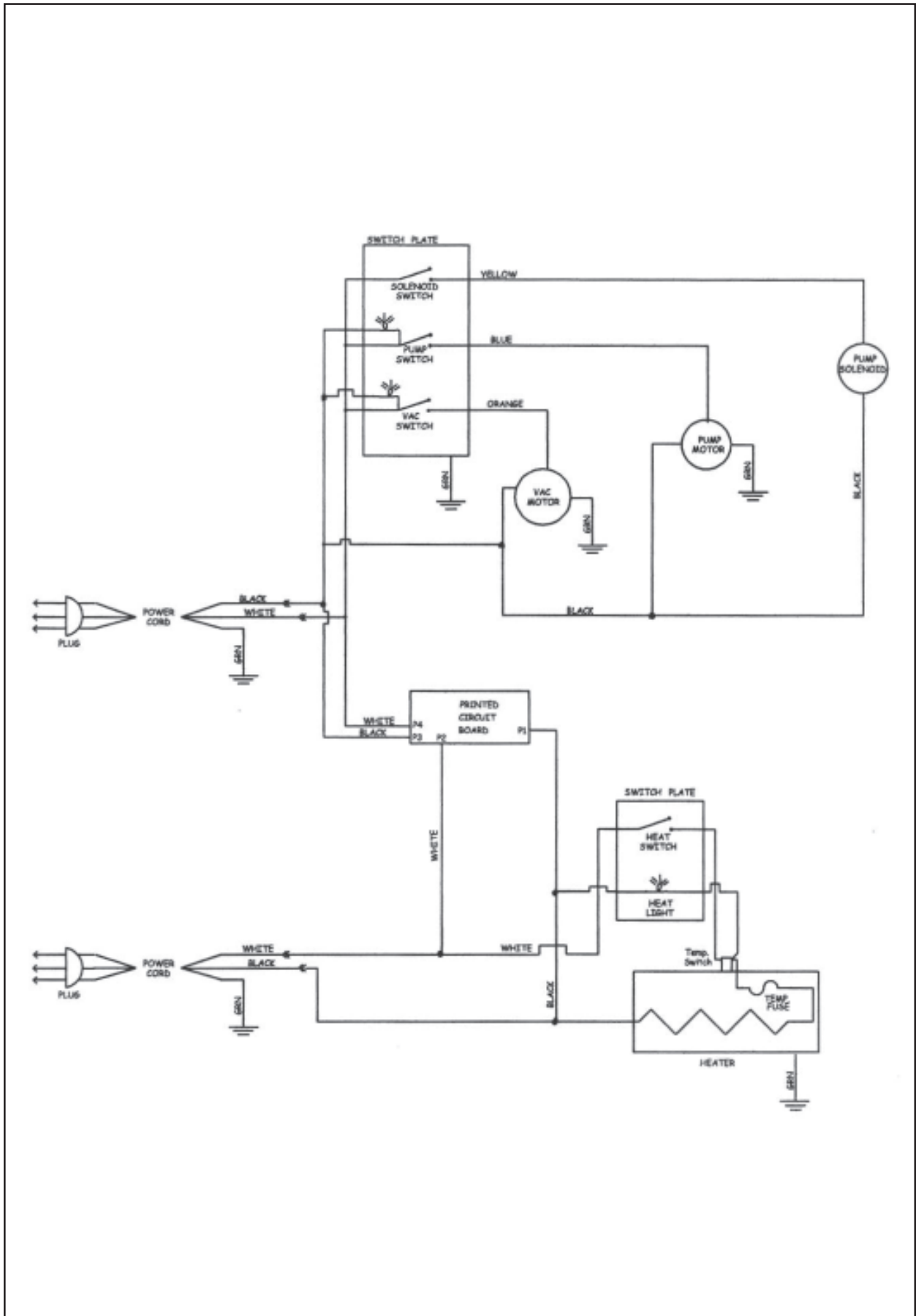











**Advance**

14600 21st Avenue North  
Plymouth, MN 55447-3408

[www.advance-us.com](http://www.advance-us.com)

Phone: 800-989-2235

Fax: 800-989-6566

©2010 Nilfisk-Advance, Inc.

---

**A Nilfisk-Advance Brand**