

**Spare parts list**  
**(5.971-093.0) Spare parts list B 140 R**

## Table of contents

---

<b>Spare parts list B 140 R (5.971-093.0)</b> .....	<b>4</b>
10 BASE FRAME (0.165-257.0).....	5
11 BASE FRAME (0.165-258.0).....	6
12 Control console (0.164-396.0).....	9
13 CONTROL ELECTRONICS (0.165-260.0).....	11
14 Battery (0.165-259.0).....	14
15 Water filling system battery (0.165-934.0).....	16
20 TANK (DIRTY WATER) (0.165-261.0).....	18
21 TANK (DIRTY WATER) (0.165-262.0).....	19
22 Suction hose (0.164-400.0).....	21
23 VACUUM MOTOR (0.165-263.0).....	23
30 WATER (0.165-264.0).....	26
31 BALL VALVE (0.165-265.0).....	27
32 WATER FILTER (0.165-266.0).....	29
40 STEERING (0.165-267.0).....	31
50 SUCTION PART (0.165-268.0).....	34
51 Suction beam retraction (0.165-269.0).....	35
52 Suction bar (0.164-832.0).....	37
Suction bar curved 940AB (4.777-312.0).....	40
Spare parts list suction bar curved 940A (5.971-951.0).....	41
Suction bar 940AB (4.777-302.0).....	42
Spare parts list suction bar 940AB (5.971-949.0).....	43
10 Suction bar straight 940mm (0.166-280.0).....	44
53 Suction bar (0.110-242.0).....	46
Suction bar curved 940mm (4.777-412.0).....	49
Spare parts list suction bar curved 940m (5.971-897.0).....	50
10 Suction bar curved 940mm (0.166-279.0).....	51
Suction bar straight 940mm (4.777-402.0).....	53
Spare parts list suction bar straight 94 (5.971-896.0).....	54
10 Suction bar straight 940mm (0.166-278.0).....	55
60 POWER BRUSH (0.165-270.0).....	57
61 Power brush BR (0.165-276.0).....	58
62 Roll pad BR (0.165-274.0).....	63
63 Power brush BD (0.165-271.0).....	65
64 ELEVATING MECHANISM (0.165-275.0).....	70
65 Add-on kit side strip stiffener (0.165-898.0).....	72
70 Suction hose (0.164-346.0).....	74
80 Metering unit chemistry (0.164-401.0).....	76
200 Special tools (0.120-581.0).....	78
200 Tool measuring instrument current AC/DC, (0.120-008.0).....	79
210 Tool tool - extractor system Molex (0.120-082.0).....	81
220 Tool tool - extractor -Bolt Circle (0.120-083.0).....	83
230 Tool torque key 2-25Nm (0.120-084.0).....	85
240 Tool magnetic brake adapter (0.120-085.0).....	87
250 Tool service module A9 (0.120-086.0).....	89
260 Tool hydrometer acid (0.120-087.0).....	91

## Table of contents

---

270 Tool potentiometer DC (0.120-088.0).....	93
280 Tool magnetic field tester (0.120-104.0).....	95
290 Tool tester electric Metratester5 (0.120-160.0).....	97

Spare parts list B 140 R (5.971-093.0)

---

Pos	Name	Qty.	Unit
10	BASE FRAME	1.000	ST
20	TANK (DIRTY WATER)	1.000	ST
30	WATER	1.000	ST
40	STEERING	1.000	ST
50	SUCTION PART	1.000	ST
60	POWER BRUSH	1.000	ST
70	Suction hose	1.000	ST
80	Metering unit chemistry	1.000	ST
200	Special tools	1.000	ST

---



10 BASE FRAME (0.165-257.0)

---

Pos	Name	Qty.	Unit
11	BASE FRAME	1.000	ST
12	Control console	1.000	ST
13	CONTROL ELECTRONICS	1.000	ST
14	Battery	1.000	ST
15	Water filling system battery	1.000	ST

---

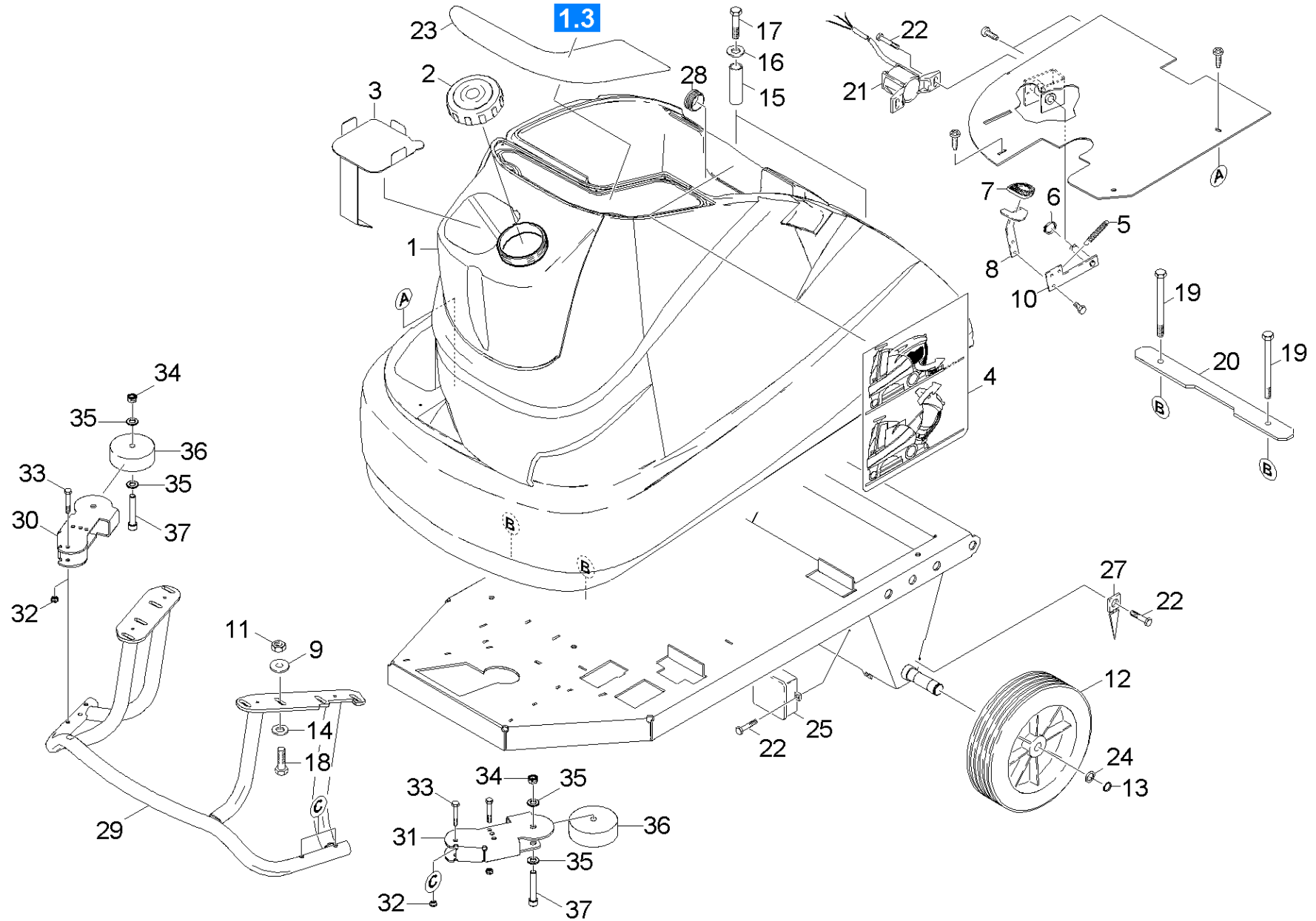

11 BASE FRAME (0.165-258.0)

ET/VT (spare/wear parts)	Pos	Material #	Name	Qty.	Unit	from ser.nr.	up to ser.nr.	Footnote text
	1	4.071-209.0	Fresh water tank only for replacement B	1.000	ST			GREY
	1	4.071-171.0	Tank fresh water replacement	1.000	ST	0000000000	0000000000	YELLOW
X-X	2	4.392-023.0	Cover complete	1.000	ST	0000000000	0000000000	BLACK
	3	5.033-106.0	Plate bottom fresh water tank ohne DOSE	1.000	ST			
	4	5.385-078.0	Label tank kippen	1.000	ST	0000000000	0000000000	
X-X	5	6.330-091.0	Extension spring	1.000	ST	0000000000	0000000000	
X-X	6	7.343-005.0	Locking ring 16x1-FST-PHR DIN 471	1.000	ST	0000000000	0000000000	
X-X	7	6.321-046.0	Coating pedal	1.000	ST	0000000000	0000000000	
	8	5.011-883.0	Plate pedal	1.000	ST			YELLOW
	8	5.011-883.0	Plate pedal	1.000	ST	0000000000	0000000000	BLACK
X-X	9	7.312-289.0	Washer 8 -A2 ISO 7093-1	8.000	ST			
	10	4.481-182.0	Lever pedal complete	1.000	ST	0000000000	0000000000	
X	11	7.311-004.0	Hexagon nut M8 -8-A3E ISO 4032	8.000	ST			
X-X	12	6.435-738.0	Wheel oil resistant D300	2.000	ST	0000000000	0000000000	BLACK
X	12	6.435-844.0	Wheel oil resistant D300	2.000	ST			GREY
X-X	13	7.343-008.0	Locking ring 25x1,2-St-vz DIN 471	2.000	ST	0000000000	0000000000	
X-X	14	7.312-017.0	Washer 8-A2 ISO 7089	8.000	ST			
	15	5.110-511.0	Sleeve	2.000	ST	0000000000	0000000000	
	16	7.312-261.0	Washer 8 -100HV-A3E ISO 7094	2.000	ST	0000000000	0000000000	
X-X	17	7.304-504.0	Hexagonal head screw M8x50-A2-70 ISO 40	2.000	ST	0000000000	0000000000	
X-X	18	7.304-399.0	Hexagonal head screw M 8x25-8.8-A2E ISO	8.000	ST			
	19	7.304-023.0	Hexagonal head screw M8x130-A4-70 ISO 4	2.000	ST	0000000000	0000000000	
	20	5.008-999.0	Plate fixing fresh water tank	1.000	ST	0000000000	0000000000	
X-X	21	6.600-300.0	Tachograph sensor B	1.000	ST	0000000000	0000000000	
	22	7.303-039.0	Screw M5x16 -St-A2R (In6Rd)	4.000	ST	0000000000	0000000000	

11 BASE FRAME (0.165-258.0)

ET/VT (spare/wear parts)	Pos	Material #	Name	Qty.	Unit	from ser.nr.	up to ser.nr.	Footnote text
X-X	23	6.273-196.0	Seal string cellular rubber	1.000	M	0000000000	0000000000	TO ORDER AS CUT GOODS
X-X	24	7.343-215.0	Shim ring 25x36x1,0-ST2K50 DIN 988	2.000	ST	0000000000	0000000000	
	25	6.651-364.0	Junction box	1.000	ST	0000000000	0000000000	
X	27	6.600-265.0	Grounding tongue	1.000	ST	0000000000	0000000000	
	28	6.642-111.0	Plug 42mm	1.000	ST			
	29	4.040-806.0	Ram protection B 140	1.000	ST			
	30	5.010-340.0	Holder deflector roll right	1.000	ST			
	31	5.010-341.0	Holder deflector roll left	1.000	ST			
X-X	32	7.311-427.0	Hexagon nut M8 -04-A2E ISO 10511	4.000	ST			
X-X	33	7.306-222.0	Cylinder head screw M8x55 -A4-70 ISO 47	4.000	ST			
X-X	34	7.311-026.0	Hexagon nut M12-1.4305 ISO 10511	2.000	ST			
X-X	35	7.312-054.0	Washer 12-A2 ISO 7090	4.000	ST			
X-X	36	5.515-096.0	Roller	2.000	ST			
X-X	37	7.306-146.0	Cylinder head screw M12x70 -A4-70 ISO 4	2.000	ST			

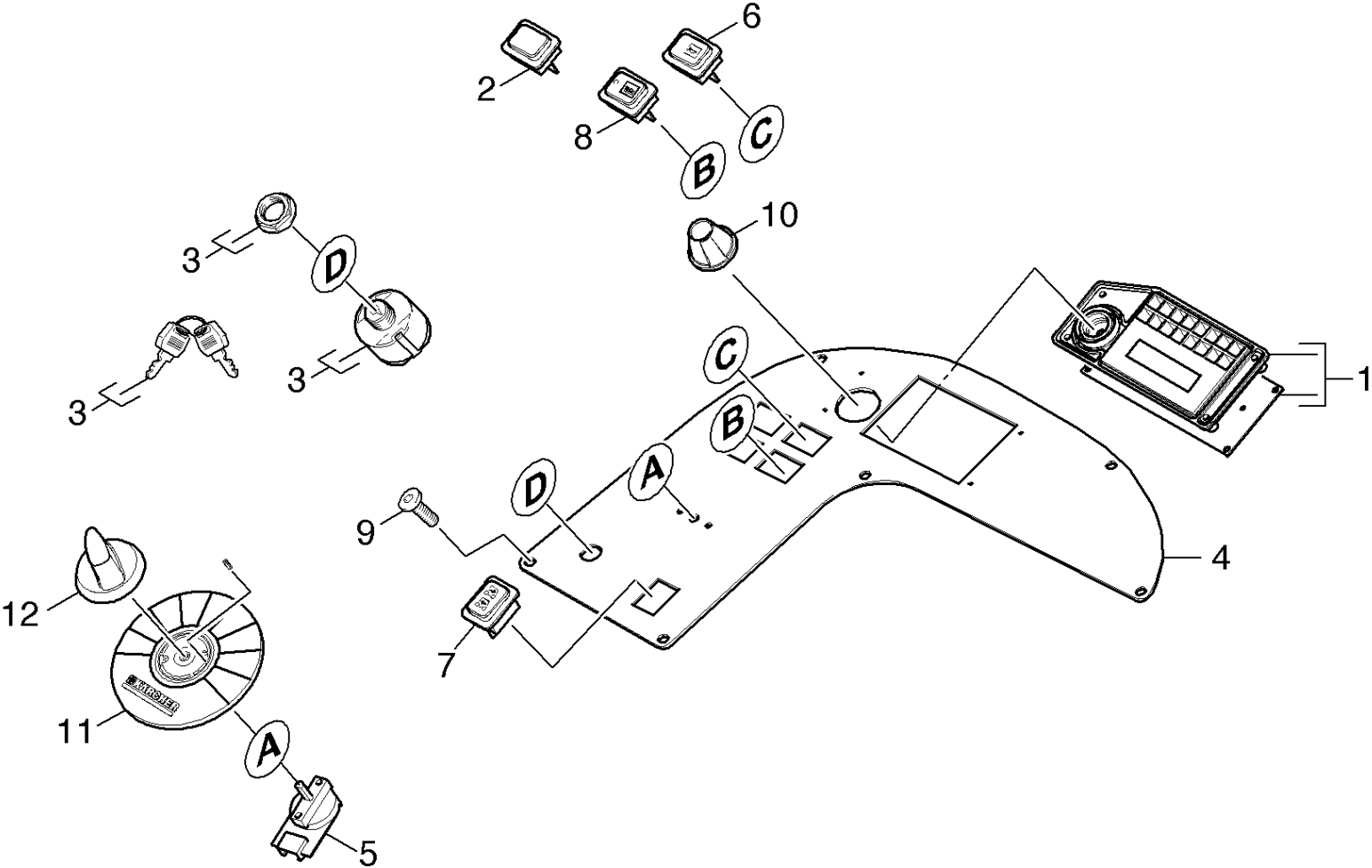

12 Control console (0.164-396.0)

ET/VT (spare/wear parts)	Pos	Material #	Name	Qty.	Unit	from ser.nr.	up to ser.nr.	var. information
X-X	1	4.841-161.0	Control panel info panel + CPU	1.000	ST	0000000000	0000000000	
X	2	6.368-286.0	Protecting cap 35*25	5.000	ST	0000000000	0000000000	
X-X	3	6.630-106.0	Key switch	1.000	ST	0000000000	0000000000	
X	4	4.387-005.0	Plate control panel with Folie	1.000	ST			
X-X	5	2.630-001.0	Switch program selection	1.000	ST	0000000000	0000000000	
X	6	6.632-475.0	Pushbutton two-pole hooter	1.000	ST			
Position text: 1.246-007.0 / -008.0 / -009.0 / -010.0 / -011.0 / -012.0 / -013.0								
X	6	6.632-366.0	Pushbutton two-pole hooter	1.000	ST	0000000000	0000000000	
Position text: 1.246-001.0 / -002.0 / -003.0 / -004.0 / -005.0 / -006.0								
X-X	7	6.632-482.0	Switch two-pole direction of travelling	1.000	ST			
Position text: 1.246-007.0 / -008.0 / -009.0 / -010.0 / -011.0 / -012.0 / -013.0								
X	7	6.632-367.0	Switch 2-polig Fahrtrichtung	1.000	ST	0000000000	0000000000	
Position text: 1.246-001.0 / -002.0 / -003.0 / -004.0 / -005.0 / -006.0								
X	8	6.632-483.0	Switch chemistry	1.000	ST			/""DOSE""
Position text: 1.246-002.0 / -004.0 / -006.0 / -010.0 / -011.0 / -012.0								
X-X	9	7.303-107.0	Screw 5x16 -10.9-P2R (K-In6Rd)	6.000	ST	0000000000	0000000000	
X-X	10	5.321-750.0	Handhold info panel	1.000	ST	0000000000	0000000000	
X-X	11	5.032-746.0	Moulded part	1.000	ST	0000000000	0000000000	
X-X	12	5.321-738.0	Handhold operational concept	1.000	ST	0000000000	0000000000	

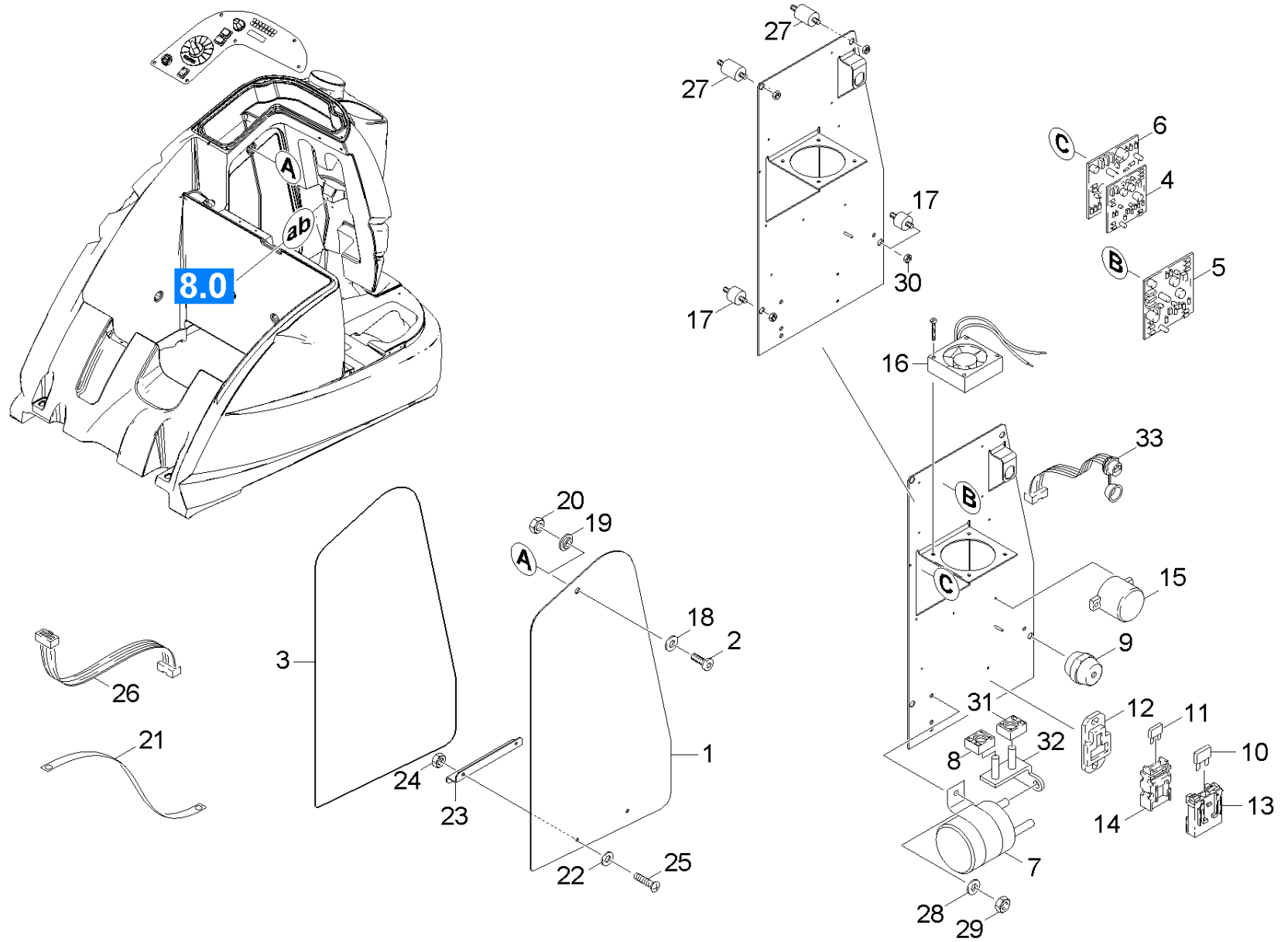

13 CONTROL ELECTRONICS (0.165-260.0)

ET/VT (spare/wear parts)	Pos	Material #	Name	Qty.	Unit	from ser.nr.	up to ser.nr.	var. information	Footnote text
	1	5.008-928.0	Plate covering cap control system	1.000	ST	0000000000	0000000000		
X-X	2	7.306-022.0	Cylinder head screw M 6x20-8.8-A2E ISO47	1.000	ST	0000000000	0000000000		
X-X	3	6.286-113.0	Sealing profile	1.000	M	0000000000	0000000000		TO ORDER AS CUT GOODS
X-X	4	6.682-979.0	Control circuit board drive module 24V /	1.000	ST	0000000000	0000000000		
X-X	5	6.682-747.0	Control circuit board lifting module	1.000	ST	0000000000	0000000000		
X-X	6	6.683-174.0	Control circuit board Cleanmodul	1.000	ST	0000000000	0000000000		
X-X	7	6.632-394.0	Contactora 24V / 180A	1.000	ST	0000000000	0000000000		
X-X	8	6.644-333.0	Fuse 150A	1.000	ST			150A	
X-X	9	6.644-348.0	Nut with flange	1.000	ST				
X-X	10	7.644-040.0	Fuse insert C30 DIN 72581-3	1.000	ST	0000000000	0000000000		
X-X	11	7.644-007.0	Fuse insert C 7,5 DIN 72581-3	1.000	ST	0000000000	0000000000		
	12	6.644-276.0	Plate	1.000	ST	0000000000	0000000000		
X	13	6.644-275.0	Fuse holder	1.000	ST	0000000000	0000000000		
X-X	14	6.644-279.0	Fuse holder	1.000	ST	0000000000	0000000000		
X-X	15	6.630-158.0	Buzzer	1.000	ST	0000000000	0000000000		
	16	6.612-896.0	Blower 12V, 2,6W	1.000	ST	0000000000	0000000000		
X-X	17	6.340-001.0	Rubber buffer D15x25	2.000	ST				
	18	7.312-027.0	Washer 6-KUNSTSTOFF ISO7089	1.000	ST				
	19	6.392-160.0	Sleeve insulating M6	1.000	ST				
X	20	7.311-512.0	Hexagon nut M 6-8-A2E ISO 7040	1.000	ST				
X	21	6.650-069.0	Earth strap with insulating	1.000	ST				
X-X	22	7.312-058.0	Washer 5 -A2 ISO 7090	2.000	ST				
	23	5.008-402.0	Plate hook electric	1.000	ST				
X	24	7.311-002.0	Hexagon nut M5 -8-A2E ISO 4032	2.000	ST				
X	25	7.306-071.0	Screw M5x10 -8.8-R2R (In6Rd)	2.000	ST				



13 CONTROL ELECTRONICS (0.165-260.0)

ET/VT (spare/wear parts)	Pos	Material #	Name	Qty.	Unit	from ser.nr.	up to ser.nr.	var. information	Footnote text
X-X	26	6.642-120.0	Data cable only for replacement ( Buskab	1.000	ST				
X-X	27	6.340-002.0	Rubber buffer D15x15	2.000	ST				
	28	7.312-045.0	Washer 6-200HV-P4E ISO 7089	1.000	ST				
X	29	7.311-512.0	Hexagon nut M 6-8-A2E ISO 7040	1.000	ST				
X-X	30	7.311-021.0	Hexagon nut M 5-8-A2E EN 1661	4.000	ST				
X-X	31	6.644-360.0	Fuse 125A	1.000	ST			125A	
X-X	32	5.008-959.0	Angle fuse control system	1.000	ST				
	33	6.639-812.0	Socket connector with flat cable RJ45	1.000	ST				

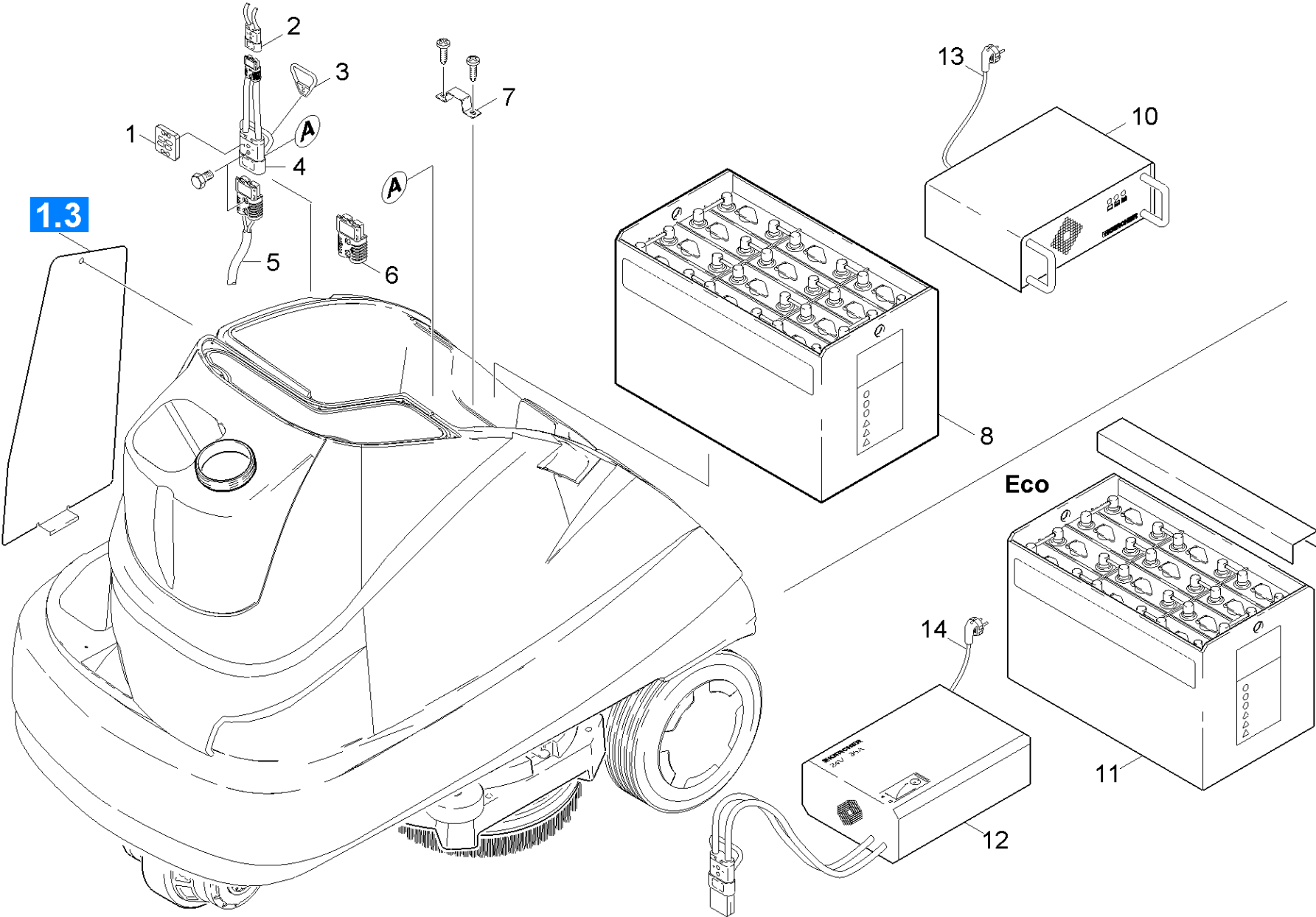

14 Battery (0.165-259.0)

ET/VT (spare/wear parts)	Pos	Material #	Name	Qty.	Unit	from ser.nr.	up to ser.nr.	var. information	Footnote text
X	1	6.277-647.0	Plate coding only for replacement	1.000	ST	0000000000	0000000000		
	2	6.649-284.0	Cable connection	1.000	ST	0000000000	0000000000		
X-X	3	6.321-152.0	Hand grip connection cable	1.000	ST	0000000000	0000000000		
X	4	6.648-924.0	Adapter cable	1.000	ST	0000000000	0000000000		LOCKING PISTON
	5	6.649-281.0	Supply cable battery	1.000	ST	0000000000	0000000000		
X	6	6.648-929.0	Plug two-pole SBE 160	1.000	ST	0000000000	0000000000	160 A	
	7	5.007-339.0	Plate cable battery	1.000	ST	0000000000	0000000000		
	8	6.654-052.0	Battery kit	1.000	ST	0000000000	0000000000		
	10	6.654-139.0	Battery charger 24V/50A	1.000	ST	0000000000	0000000000		
	11	6.654-112.0	Battery 24V 240Ah	1.000	ST				
Position text: //1.246-003.0/ -004.0 / -008.0 / -011.0/ -013.0									
X-X	12	6.654-193.0	Battery charger 24V/36A	1.000	ST				
Position text: //1.246-003.0/ -004.0 / -008.0 / -011.0									
	12	6.654-285.0	Battery charger with plug UK 24V/36A	1.000	ST				
Position text: //1.246-013.0									
	13	6.650-115.0	Power cable only for replacement	1.000	ST			Pos.10 / 6.654-139.0	
	14	6.650-117.0	Power cable only for replacement	1.000	ST			Pos.12 / 6.654-193.0	

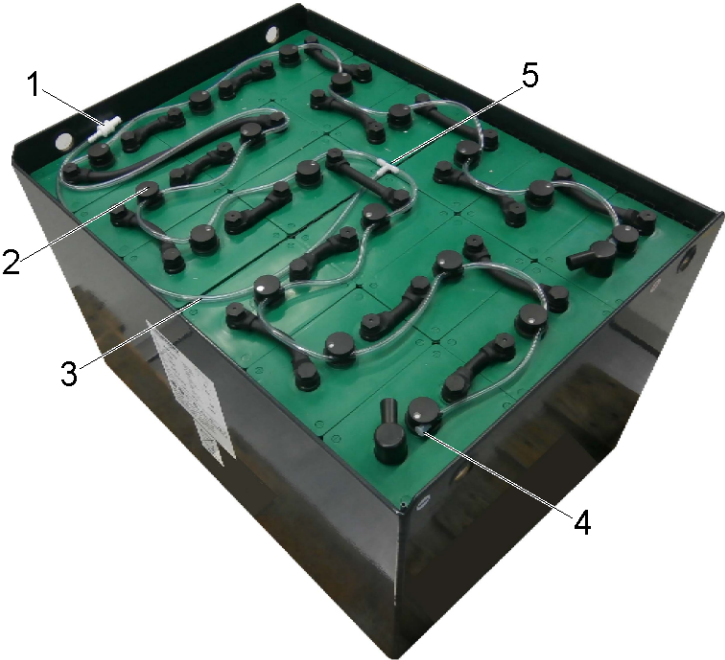

15 Water filling system battery (0.165-934.0)

ET/VT (spare/wear parts)	Pos	Material #	Name	Qty.	Unit	Footnote text
	1	6.392-926.0	Hose coupling only for replacement	1.000	ST	
X	2	6.413-561.0	Plug water filling	1.000	ST	QUANTITY ACCORDING TO DEMAND
	3	6.392-927.0	Hose only for replacement 6x1,5mm	1.000	M	TO ORDER AS CUT GOODS
	4	6.392-943.0	Plug	1.000	ST	
	5	6.392-925.0	T-Hose nozzle only for replacement	1.000	ST	
	6	6.413-562.0	Stop cock	1.000	ST	
	7	6.635-612.0	Flow monitor	1.000	ST	
X	8	6.392-942.0	Hose coupling	1.000	ST	

20 TANK (DIRTY WATER) (0.165-261.0)

---

Pos	Name	Qty.	Unit
21	TANK (DIRTY WATER)	1.000	ST
22	Suction hose	1.000	ST
23	VACUUM MOTOR	1.000	ST

---

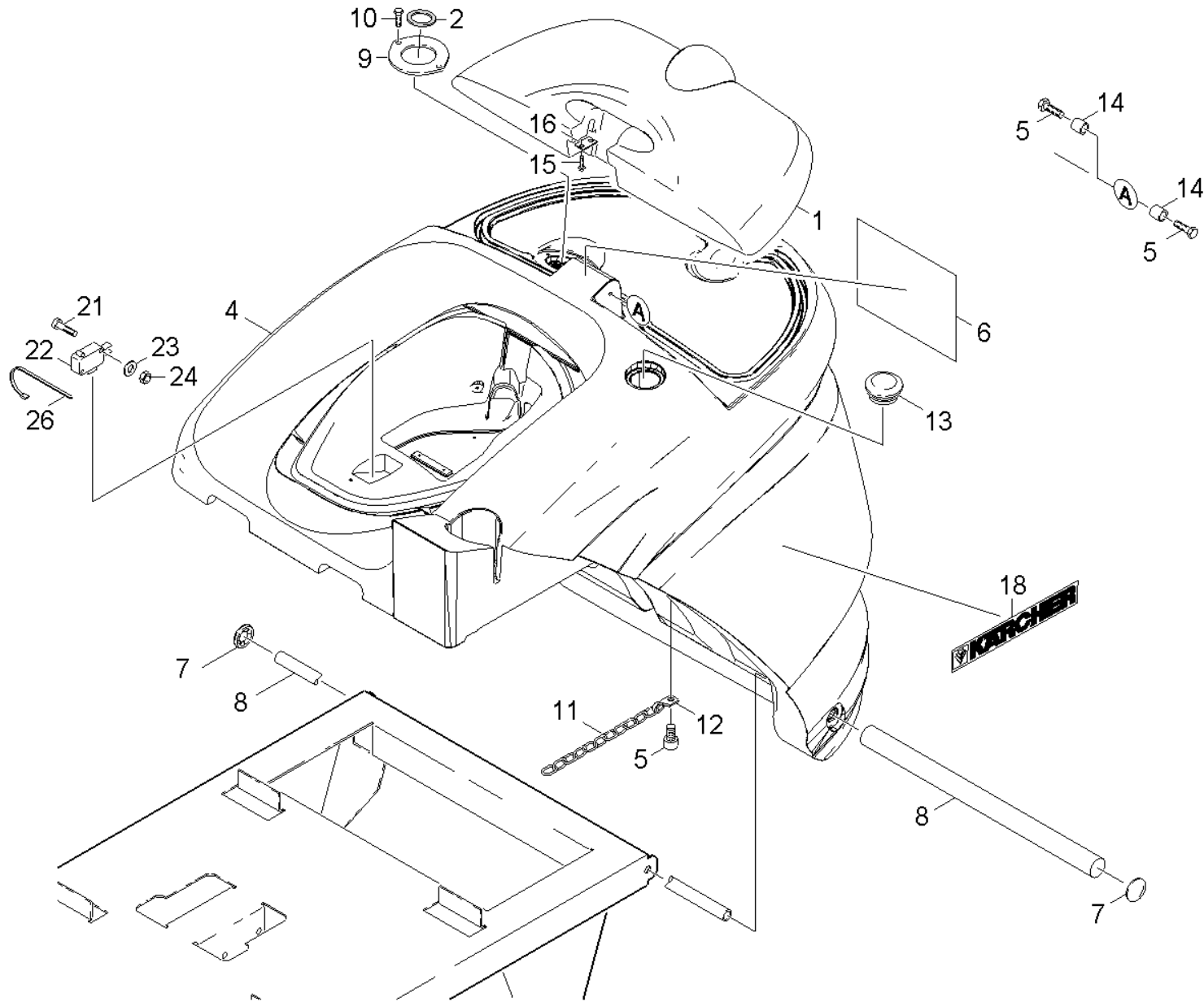

21 TANK (DIRTY WATER) (0.165-262.0)

ET/VT (spare/wear parts)	Pos	Material #	Name	Qty.	Unit	from ser.nr.	up to ser.nr.	Footnote text
	1	5.063-933.0	Cap of a tank	1.000	ST	0000000000	0000000000	
X-X	2	5.363-344.0	Joint ring	1.000	ST	0000000000	0000000000	
	4	4.071-160.0	Tank waste water complete	1.000	ST	0000000000	0000000000	YELLOW
	4	4.071-202.0	Waste water tank complete only for repla	1.000	ST			GREY
X-X	5	7.306-022.0	Cylinder head screw M 6x20-8.8-A2E ISO47	2.000	ST	0000000000	0000000000	
X-X	6	5.385-077.0	Label attention vacuum motor	1.000	ST	0000000000	0000000000	
X-X	7	6.343-122.0	Lock washer	2.000	ST	0000000000	0000000000	
	8	5.105-354.0	Axle waste water tank	1.000	ST	0000000000	0000000000	
X-X	9	5.001-752.0	Plate	1.000	ST	0000000000	0000000000	
X-X	10	7.303-104.0	Screw 5x16 -A2-70 (IN6RD)	2.000	ST			
	11	6.432-031.0	Chain 22 / 11 MM	1.000	M	0000000000	0000000000	TO ORDER AS CUT GOODS
X	12	5.001-987.0	Plate bracket fuer Kette	2.000	ST	0000000000	0000000000	
	13	5.132-124.0	Plug	1.000	ST	0000000000	0000000000	
	14	5.110-177.0	Sleeve	2.000	ST	0000000000	0000000000	
X-X	15	7.303-104.0	Screw 5x16 -A2-70 (IN6RD)	4.000	ST	0000000000	0000000000	
	16	5.004-931.0	Strap cap of a tank	2.000	ST	0000000000	0000000000	
X-X	18	5.390-521.0	Label	1.000	ST	0000000000	0000000000	
X-X	21	7.306-045.0	Screw M2x20 -8.8-A2R (In6Rd)	2.000	ST	0000000000	0000000000	
X-X	22	6.631-854.0	Micro switch	1.000	ST	0000000000	0000000000	
	23	7.312-043.0	Washer 3-A2 ISO 7089	2.000	ST	0000000000	0000000000	
X-X	24	7.311-074.0	Hexagon nut M 2-8-A2E ISO 4032	2.000	ST	0000000000	0000000000	
X-X	26	6.641-463.0	Cable tape	1.000	ST	0000000000	0000000000	



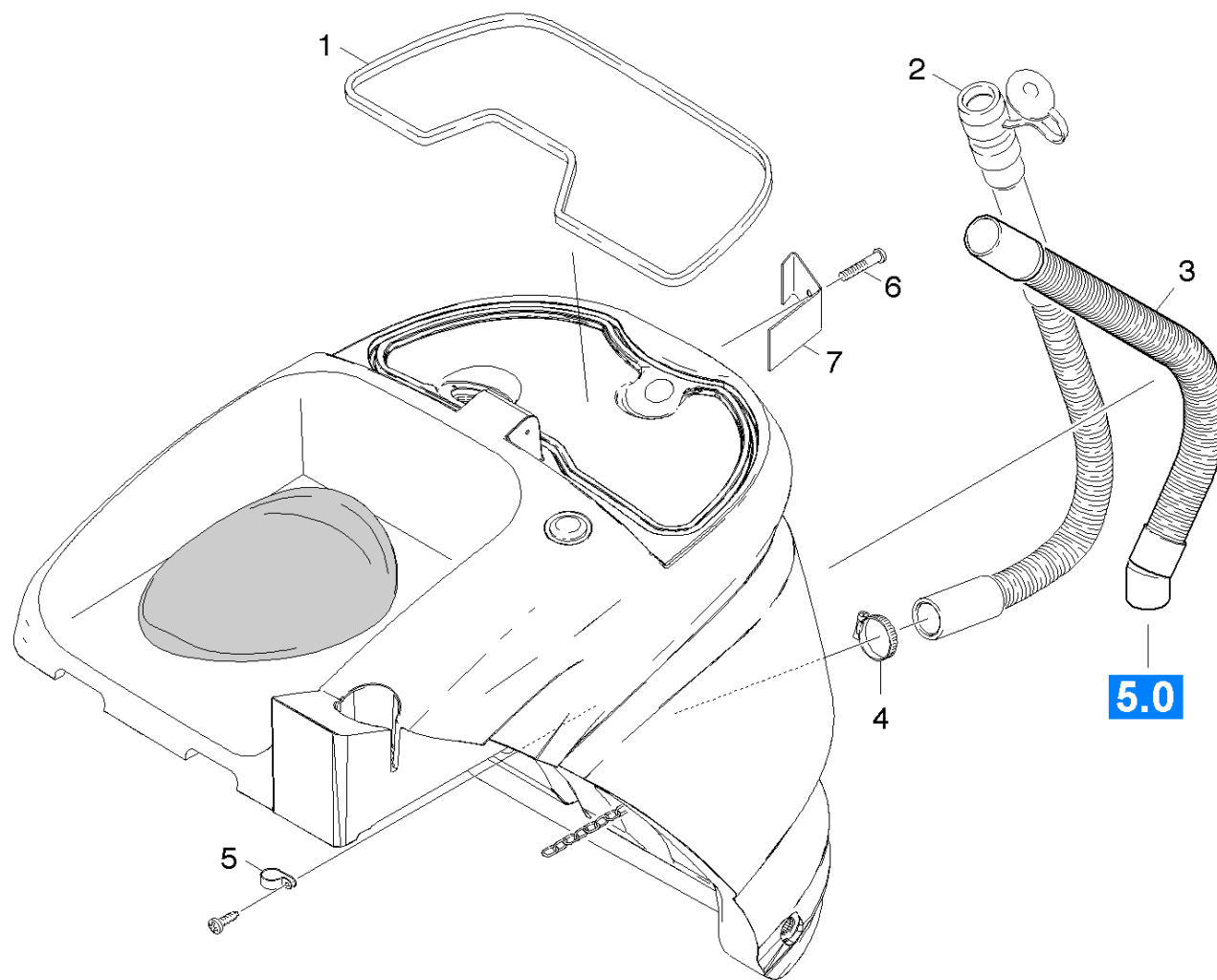

22 Suction hose (0.164-400.0)

ET/VT (spare/wear parts)	Pos	Material #	Name	Qty.	Unit	from ser.nr.	up to ser.nr.	Footnote text
X-X	1	6.366-043.0	Sealing profile	1.000	M	0000000000	0000000000	TO ORDER AS CUT GOODS
X-X	2	6.390-829.0	Drain hose DN38 BIG TRIKE, BR-BD 700	1.000	ST	0000000000	0000000000	OIL RESISTANT
X-X	2	6.390-674.0	Drain hose DN38 BIG TRIKE	1.000	ST	0000000000	0000000000	STANDARD
X-X	3	6.391-698.0	Suction hose DN 38 - Big Trike	1.000	ST			STANDARD
X-X	3	6.391-593.0	Suction hose oil resistant DN 38	1.000	ST	0000000000	0000000000	OIL RESISTANT
X-X	4	6.388-713.0	Hose clip	4.000	ST	0000000000	0000000000	
	5	6.641-460.0	Cable clamp	1.000	ST	0000000000	0000000000	
X-X	6	7.303-107.0	Screw 5x16 -10.9-P2R (K-In6Rd)	1.000	ST	0000000000	0000000000	
	7	5.044-569.0	Holder drain hose	1.000	ST	0000000000	0000000000	

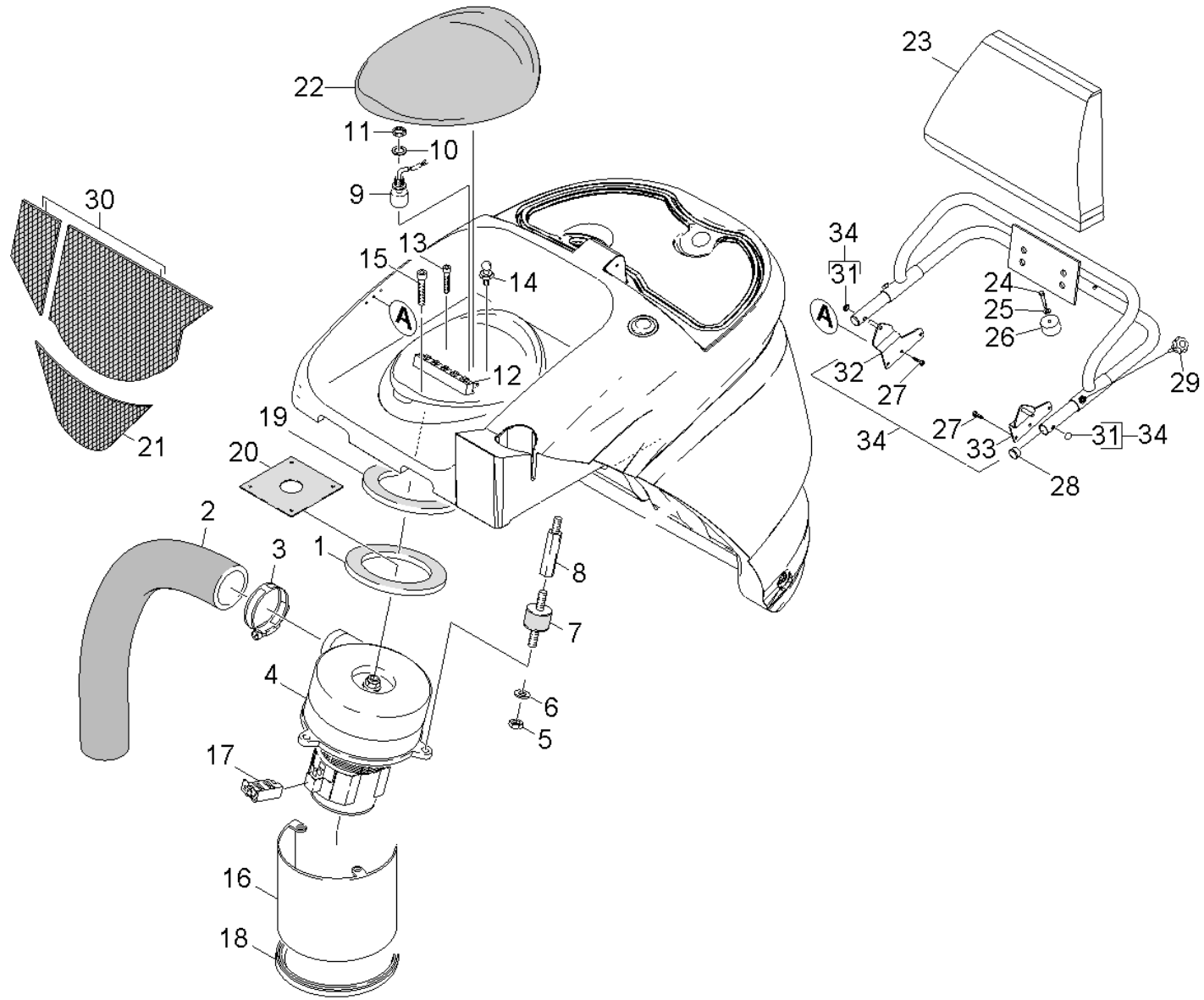

23 VACUUM MOTOR (0.165-263.0)

ET/VT (spare/wear parts)	Pos	Material #	Name	Qty.	Unit	from ser.nr.	up to ser.nr.	var. information	Footnote text
X-X	1	5.363-574.0	Joint ring	1.000	ST	0000000000	0000000000		
X-X	2	6.388-949.0	SUCTION TUBE	1.000	ST			(500mm)	
X-X	2	6.390-215.0	Soundproof hose	1.000	ST			(350mm)	
X-X	3	6.388-563.0	Hose clip	1.000	ST	0000000000	0000000000		
X-X	4	6.490-308.0	Vacuum motor 24 V	1.000	ST				
X-X	5	7.311-067.0	Hexagon nut M 6-A2-70 ISO 4032	3.000	ST	0000000000	0000000000		
X-X	6	7.312-026.0	Washer 6 -A2 ISO 7090	3.000	ST	0000000000	0000000000		
X-X	7	6.339-021.0	Rubber buffer 2xM6-D20 H15	3.000	ST	0000000000	0000000000		
X	8	5.308-068.0	Stud bolt M8x15	3.000	ST				VERSION 2
X-X	8	5.308-056.0	Stud bolt	3.000	ST				VERSION 1
X-X	9	6.631-309.0	Float regulator	1.000	ST	0000000000	0000000000		
X-X	10	6.641-654.0	Flat gasket 13X20	1.000	ST	0000000000	0000000000		
X-X	11	6.641-483.0	Locknut PG7	1.000	ST	0000000000	0000000000		
	12	6.643-556.0	Terminal clamp	1.000	ST	0000000000	0000000000		
	13	6.303-245.0	Cylinder head screw 3X18-ST-A2E	2.000	ST	0000000000	0000000000		
	14	5.316-909.0	Spherical head bolt	1.000	ST	0000000000	0000000000		
X-X	15	7.306-193.0	Screw M6x16 -A2-70 (In6Rd)	1.000	ST	0000000000	0000000000		
	16	5.006-960.0	Plate vacuum motor	1.000	ST				
	17	6.610-022.0	Carbon brush	2.000	ST			ROTAFIL	
X	18	6.368-018.0	Edge protection	1.000	M				TO ORDER AS CUT GOODS
	19	5.363-111.0	Joint ring	1.000	ST	0000000000	0000000000		
	20	5.008-134.0	Plate stiffener tank	1.000	ST	0000000000	0000000000		
	21	5.673-132.0	SOUND INSULATION	1.000	ST	0000000000	0000000000		
X	22	4.605-039.0	Housing seat complete TRIKE	1.000	ST				
	23	6.394-460.0	Seat backrest	1.000	ST				

23 VACUUM MOTOR (0.165-263.0)

ET/VT (spare/wear parts)	Pos	Material #	Name	Qty.	Unit	from ser.nr.	up to ser.nr.	var. information	Footnote text
X-X	24	7.304-537.0	Hexagonal head screw M 8x30-A4-70 ISO 4	1.000	ST				
X-X	25	7.312-017.0	Washer 8-A2 ISO 7089	1.000	ST				
X-X	26	6.339-065.0	Rubber buffer	1.000	ST				
X-X	27	7.303-112.0	Screw 6x20 -10.9-R2R (In6Rd)	6.000	ST				
	28	6.368-196.0	Drain plug	2.000	ST				
	29	6.321-054.0	Star handle M8X16	4.000	ST				BLACK
X	29	6.321-244.0	Star grip M8x15	4.000	ST				YELLOW
	30	5.673-129.0	Sound insulation	1.000	ST				
	31	6.343-132.0	Lock washer 8	2.000	ST				
X	32	4.044-119.0	Holder backrest right	1.000	ST				
	33	4.044-120.0	Holder backrest left	1.000	ST				
X	34	2.642-614.0	Conversion kit backrest fixing	1.000	ST				

30 WATER (0.165-264.0)

---

Pos	Name	Qty.	Unit
31	BALL VALVE	1.000	ST
32	WATER FILTER	1.000	ST

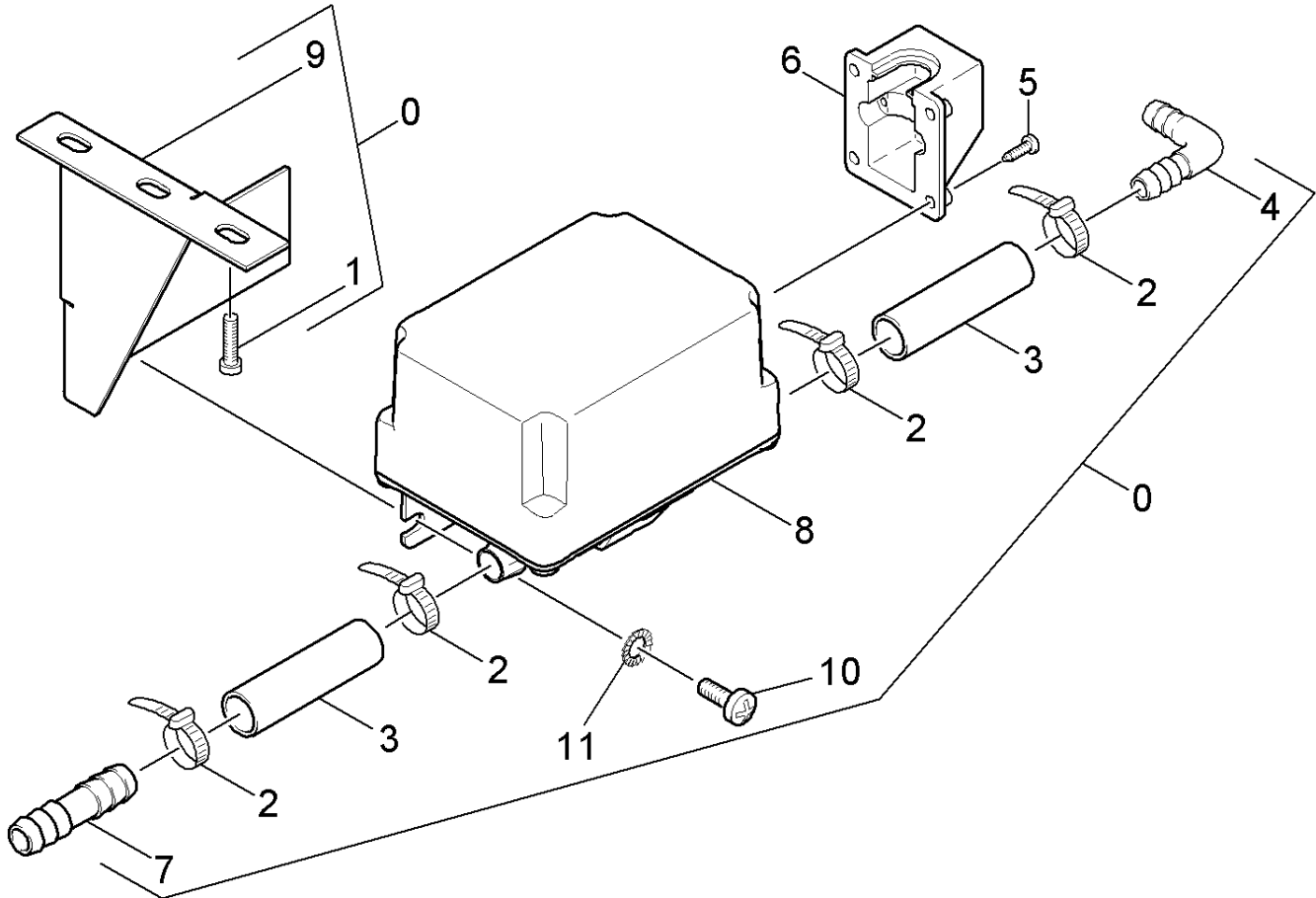

31 BALL VALVE (0.165-265.0)

ET/VT (spare/wear parts)	Pos	Material #	Name	Qty.	Unit	Footnote text
X-X	0	4.580-738.0	Conversion kit ball valve electrically	1.000	ST	
X-X	1	7.303-107.0	Screw 5x16 -10.9-P2R (K-In6Rd)	4.000	ST	
X-X	2	6.641-474.0	Cable tape 8-210	4.000	ST	
X-X	3	6.388-248.0	Hose DN12,5	1.000	M	TO ORDER AS CUT GOODS
X	4	6.388-628.0	Elbow connector 1/2"	1.000	ST	
	5	7.303-095.0	Screw 4x 12-ST-10.9-R2R (IN6RD)	4.000	ST	
	6	5.032-761.0	Elbow connector ball valve	1.000	ST	
	7	6.388-752.0	Hose stem DN13	1.000	ST	
X-X	8	4.464-020.0	Ball valve electrically complete	1.000	ST	
	9	5.062-139.0	Plate adapter	1.000	ST	
X-X	10	7.306-191.0	Screw M6x10 -A2-70 (In6Rd)	2.000	ST	
X-X	11	7.312-020.0	Serrated lock washer A6,4-1.4310 DIN679	2.000	ST	



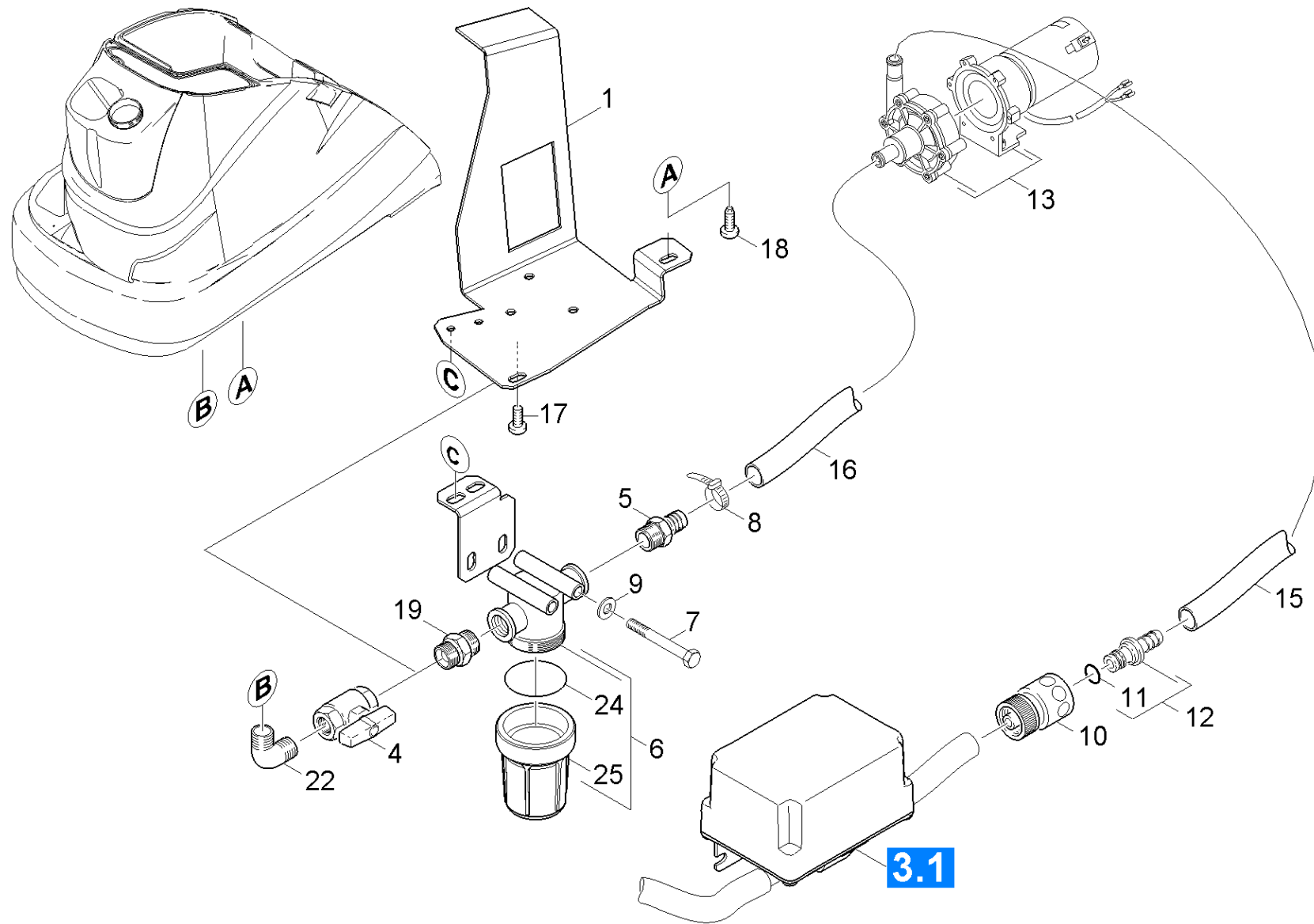

32 WATER FILTER (0.165-266.0)

ET/VT (spare/wear parts)	Pos	Material #	Name	Qty.	Unit	from ser.nr.	up to ser.nr.	Footnote text
	1	5.010-365.0	Bracket pump	1.000	ST	0000000000	0000000000	
X	2	6.387-877.0	Angle A4-1/2"-2.1096	1.000	ST	0000000000	0000000000	
X-X	3	6.387-878.0	Double nipple N8-1/2"-2.1096	1.000	ST	0000000000	0000000000	
X-X	4	6.413-378.0	Stop cock R 1/2 zoll	1.000	ST	0000000000	0000000000	YELLOW
X-X	4	6.413-539.0	Stop cock G 1/2"	1.000	ST			GREY
X-X	5	6.389-692.0	Hose stem 1/2"	1.000	ST	0000000000	0000000000	
X-X	6	6.906-703.0	Filter fresh water	1.000	ST	0000000000	0000000000	BLACK
X-X	6	6.907-203.0	Filter fresh water	1.000	ST			GREY
X-X	7	7.304-233.0	Hexagonal head screw M 6X 70-A4-70 ISO	2.000	ST	0000000000	0000000000	
X-X	8	6.641-474.0	Cable tape 8-210	5.000	ST	0000000000	0000000000	
X-X	9	7.312-026.0	Washer 6 -A2 ISO 7090	2.000	ST	0000000000	0000000000	
	10	6.388-482.0	Hose coupling	1.000	ST	0000000000	0000000000	
X-X	11	6.362-170.0	O-Ring seal 11,3 X 2,4-NBR 70	1.000	ST	0000000000	0000000000	
X-X	12	5.443-375.0	Hose stem	1.000	ST	0000000000	0000000000	
X-X	13	4.540-126.0	Pump 3/4"	1.000	ST	0000000000	0000000000	
X-X	15	6.388-248.0	Hose DN12,5	1.000	M	0000000000	0000000000	TO ORDER AS CUT GOODS
X-X	16	6.390-324.0	Hose DN15	1.000	M	0000000000	0000000000	TO ORDER AS CUT GOODS
X	17	7.306-207.0	Screw M4x12 -A2-70 (In6Rd)	3.000	ST	0000000000	0000000000	
X-X	18	7.303-107.0	Screw 5x16 -10.9-P2R (K-In6Rd)	2.000	ST	0000000000	0000000000	
X-X	19	6.387-878.0	Double nipple N8-1/2"-2.1096	1.000	ST	0000000000	0000000000	
	22	6.387-494.0	Angle A8-1/2"-W400-05-V	1.000	ST	0000000000	0000000000	
X-X	24	6.363-600.0	O-Ring seal	1.000	ST			
X-X	25	6.414-985.0	Filter cup	1.000	ST			

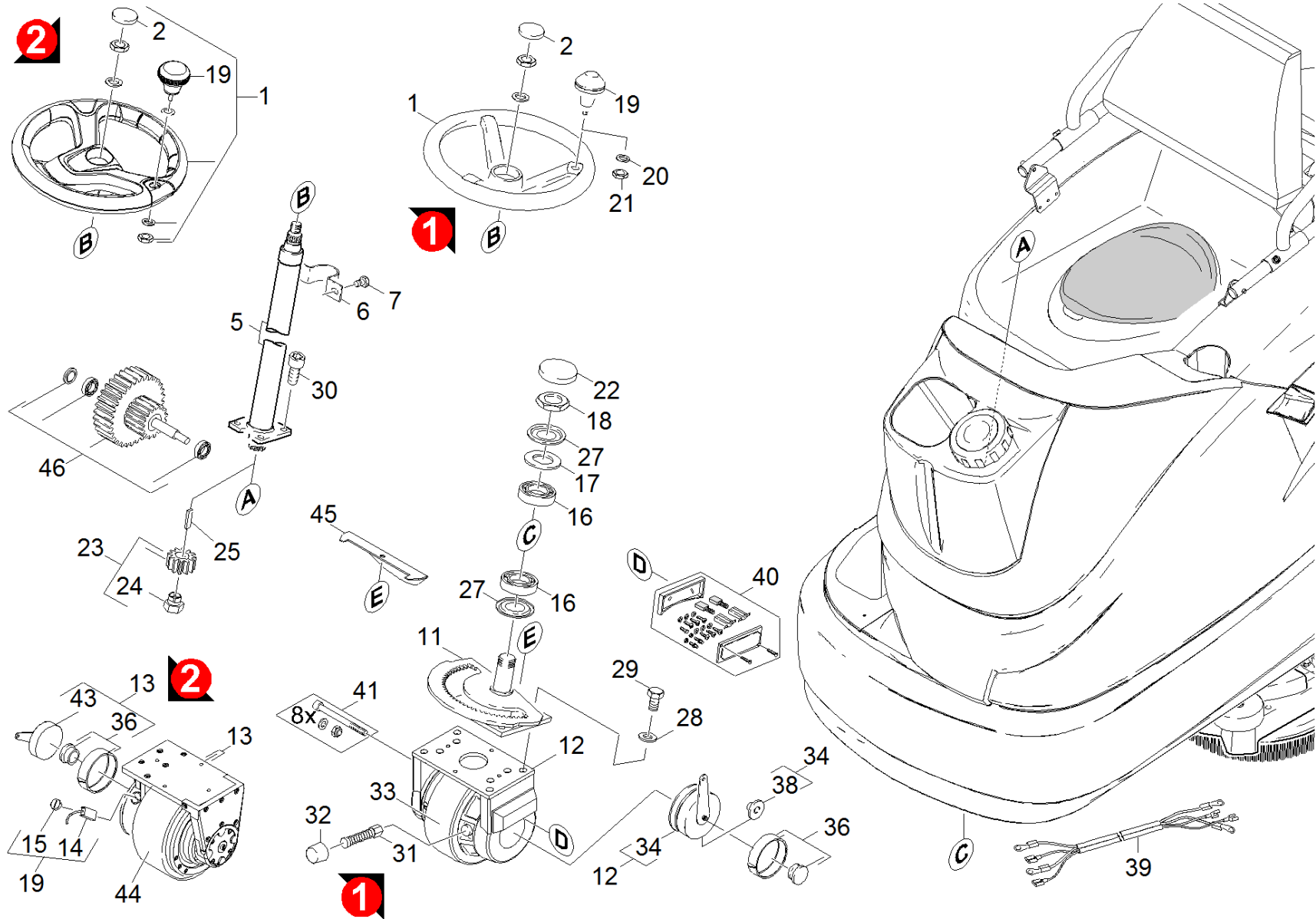

40 STEERING (0.165-267.0)

ET/VT (spare/wear parts)	Pos	Material #	Name	Qty.	Unit	from ser.nr.	up to ser.nr.	Footnote text
	1	6.435-253.0	Steering wheel	1.000	ST	0000000000	0000000000	VERSION 1
X	1	6.435-814.0	Steering wheel with handle	1.000	ST			VERSION 2
	2	6.368-217.0	Cap	1.000	ST	0000000000	0000000000	VERSION 1
X-X	2	6.640-353.0	Cap steering wheel KÄRCHER	1.000	ST			VERSION 2
	5	6.439-206.0	Steering pillar	1.000	ST			
	6	5.044-518.0	Holder steering pillar	1.000	ST	0000000000	0000000000	
	7	7.304-395.0	Hexagonal head screw M8x16-8.8-A2E ISO	2.000	ST	0000000000	0000000000	
X	11	4.040-007.0	Steering	1.000	ST	0000000000	0000000000	
	12	6.613-314.0	Wheel drive motor	1.000	ST	0000000000	0000000000	VERSION 1
X-X	13	6.613-206.0	Wheel drive motor 600W	1.000	ST			VERSION 2
X-X	14	6.613-231.0	Carbon brush set	1.000	ST			VERSION 2
X-X	15	6.961-924.0	Cover closure	1.000	ST			VERSION 2
	16	6.401-260.0	Angular contact ball bearing	2.000	ST	0000000000	0000000000	
X	17	7.312-010.0	Washer 24 -200HV-A3E ISO 7090	1.000	ST	0000000000	0000000000	
X-X	18	7.311-122.0	Hexagon nut M24X1,5-22H-A2E DIN 936	1.000	ST	0000000000	0000000000	
X-X	19	6.321-142.0	Handhold	1.000	ST	0000000000	0000000000	VERSION 1
X-X	19	6.640-354.0	Handle	1.000	ST			VERSION 2
X-X	20	7.312-004.0	Washer 8 -200HV-A3E ISO 7090	1.000	ST	0000000000	0000000000	VERSION 1
X-X	21	7.311-427.0	Hexagon nut M8 -04-A2E ISO 10511	1.000	ST	0000000000	0000000000	VERSION 1
X	22	6.368-215.0	Cap	1.000	ST	0000000000	0000000000	
X	23	4.640-204.0	Set gear wheel nur fuer ersatz	1.000	ST			
	24	7.311-434.0	Hexagon nut M14x1,5-6-A2E ISO 10512	1.000	ST			
X-X	25	7.318-084.0	Parallel key 5x5x12 -C45R DIN 6885-1	1.000	ST	0000000000	0000000000	
X-X	27	6.401-263.0	Slip ring	2.000	ST	0000000000	0000000000	
	28	7.304-415.0	Hexagonal head screw M10x25-8.8-A3E ISO	4.000	ST	0000000000	0000000000	

40 STEERING (0.165-267.0)

ET/VT (spare/wear parts)	Pos	Material #	Name	Qty.	Unit	from ser.nr.	up to ser.nr.	Footnote text
X-X	29	7.313-005.0	Spring washer B10-FSt-A3E DIN 127	4.000	ST	0000000000	0000000000	
X	30	7.306-063.0	Cylinder head screw M10x30-8.8-A3E ISO4	4.000	ST	0000000000	0000000000	
X-X	31	6.610-211.0	Carbon brush set	1.000	ST	0000000000	0000000000	VERSION 1
X-X	32	6.961-714.0	Cap carbon brushes	1.000	ST	0000000000	0000000000	VERSION 1
X-X	33	6.435-729.0	Tire wheel drive motor convex	1.000	ST	0000000000	0000000000	VERSION 1
X-X	34	6.467-043.0	Brake wheel drive motor	1.000	ST			VERSION 1
X-X	36	6.467-039.0	Retrofit kit brake	1.000	ST	0000000000	0000000000	
X-X	38	6.394-391.0	Coupler brake BR/BD TRIKE	1.000	ST	0000000000	0000000000	VERSION 1
X-X	39	6.650-075.0	Cable set nur für Ersatz	1.000	ST			
X-X	40	6.610-328.0	Spare part set terminal box wheel drive	1.000	ST			
X-X	41	6.610-329.0	Spare part set screw rim	1.000	ST			
X-X	43	4.467-002.0	Brake adjustable complete	1.000	ST			VERSION 2
X-X	44	6.435-854.0	Wheel drive wheel motor	1.000	ST			VERSION 2
X	45	5.011-858.0	Sheet metal component wheel protection	1.000	ST			
	46	6.550-040.0	Set armature shaft fuer Fahrmotor	1.000	ST			

50 SUCTION PART (0.165-268.0)

---

Pos	Name	Qty.	Unit	Footnote text
51	Suction beam retraction	1.000	ST	
52	Suction bar	1.000	ST	VERSION 1
53	Suction bar	1.000	ST	VERSION 2

---

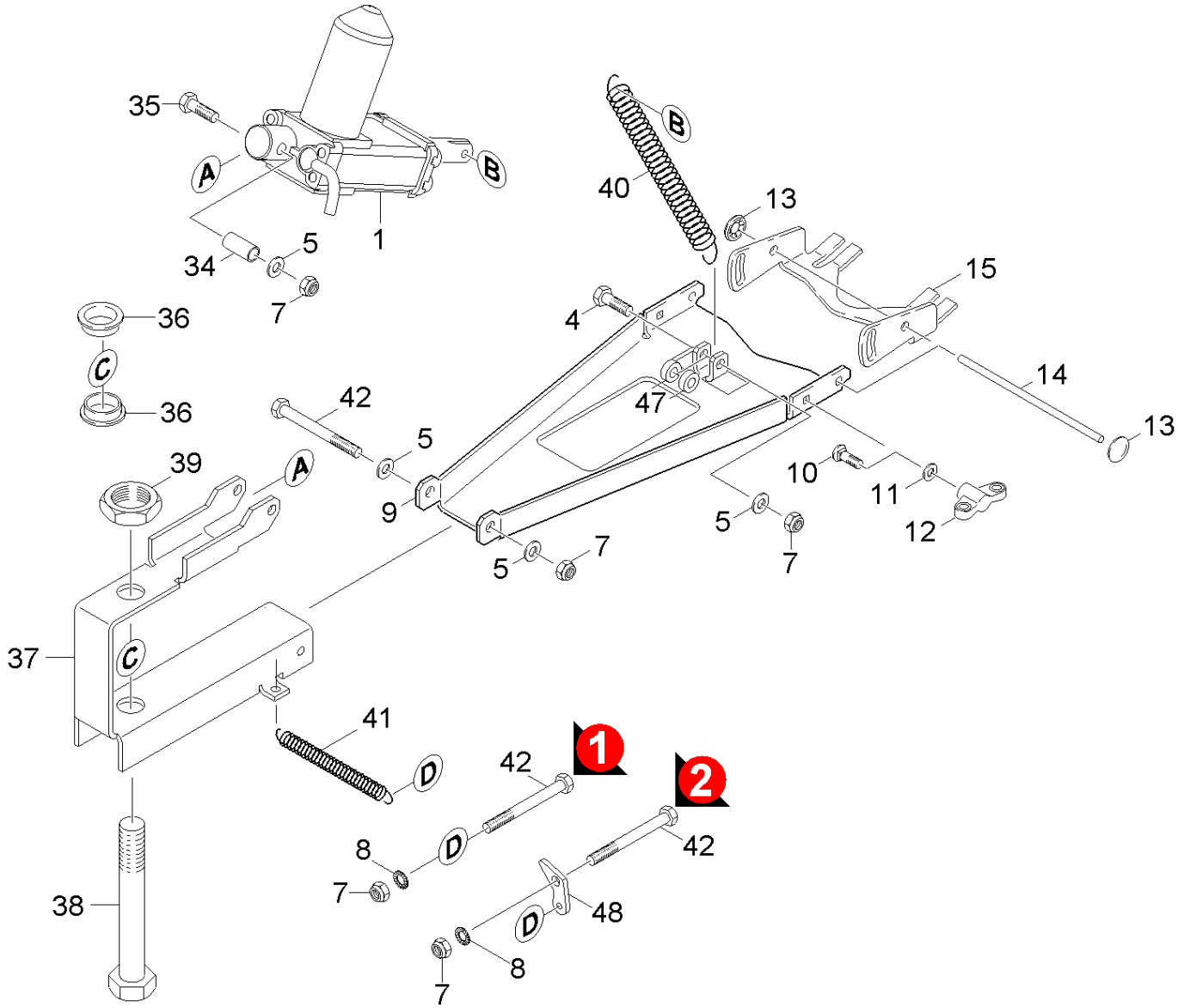

51 Suction beam retraction (0.165-269.0)

ET/VT (spare/wear parts)	Pos	Material #	Name	Qty.	Unit	from ser.nr.	up to ser.nr.	Footnote text
X-X	1	6.613-300.0	Hoisting motor 24V	1.000	ST	0000000000	0000000000	
X-X	4	7.304-407.0	Hexagonal head screw M 8x45-8.8-A2E ISO	1.000	ST	0000000000	0000000000	
X-X	5	7.312-004.0	Washer 8 -200HV-A3E ISO 7090	4.000	ST	0000000000	0000000000	
X-X	7	7.311-427.0	Hexagon nut M8 -04-A2E ISO 10511	4.000	ST	0000000000	0000000000	
X-X	8	7.312-022.0	Serrated lock washer A8,4-1.4310 DIN679	2.000	ST	0000000000	0000000000	
X	9	5.059-528.0	Sheet metal component	1.000	ST	0000000000	0000000000	
X-X	10	7.303-139.0	Saucer-head screw M6x20 -A2 DIN 603	1.000	ST	0000000000	0000000000	
X-X	11	7.312-026.0	Washer 6 -A2 ISO 7090	1.000	ST	0000000000	0000000000	
X-X	12	6.310-180.0	Wing nut M6	2.000	ST	0000000000	0000000000	BLACK
X-X	12	6.310-180.0	Wing nut M6	2.000	ST			GREY
	13	6.343-132.0	Lock washer 8	2.000	ST	0000000000	0000000000	
X-X	14	5.107-202.0	Bar	1.000	ST	0000000000	0000000000	
X-X	15	5.048-234.0	Rocker suction bar	1.000	ST	0000000000	0000000000	
	34	5.112-381.0	Bush	1.000	ST	0000000000	0000000000	
X-X	35	7.304-504.0	Hexagonal head screw M8x50-A2-70 ISO 40	1.000	ST	0000000000	0000000000	
X	36	6.347-084.0	Flanged bushing	2.000	ST			
	37	5.062-138.0	Sheet metal component retainer	1.000	ST			
X-X	38	7.304-034.0	Hexagonal head screw M12x120-A2-70 ISO	1.000	ST			
X-X	39	7.311-026.0	Hexagon nut M12-1.4305 ISO 10511	1.000	ST			
X-X	40	6.330-245.0	Extension spring	1.000	ST	0000000000	0000000000	
X-X	41	5.332-278.0	Helical spring	2.000	ST	0000000000	0000000000	
	42	7.304-097.0	Hexagonal head screw M8x70-8.8-A2E ISO	2.000	ST	0000000000	0000000000	
	47	2.885-062.0	Conversion kit spacer for Hubmotor	1.000	ST			
X-X	48	5.011-616.0	Sheet metal component spring B140R	2.000	ST			



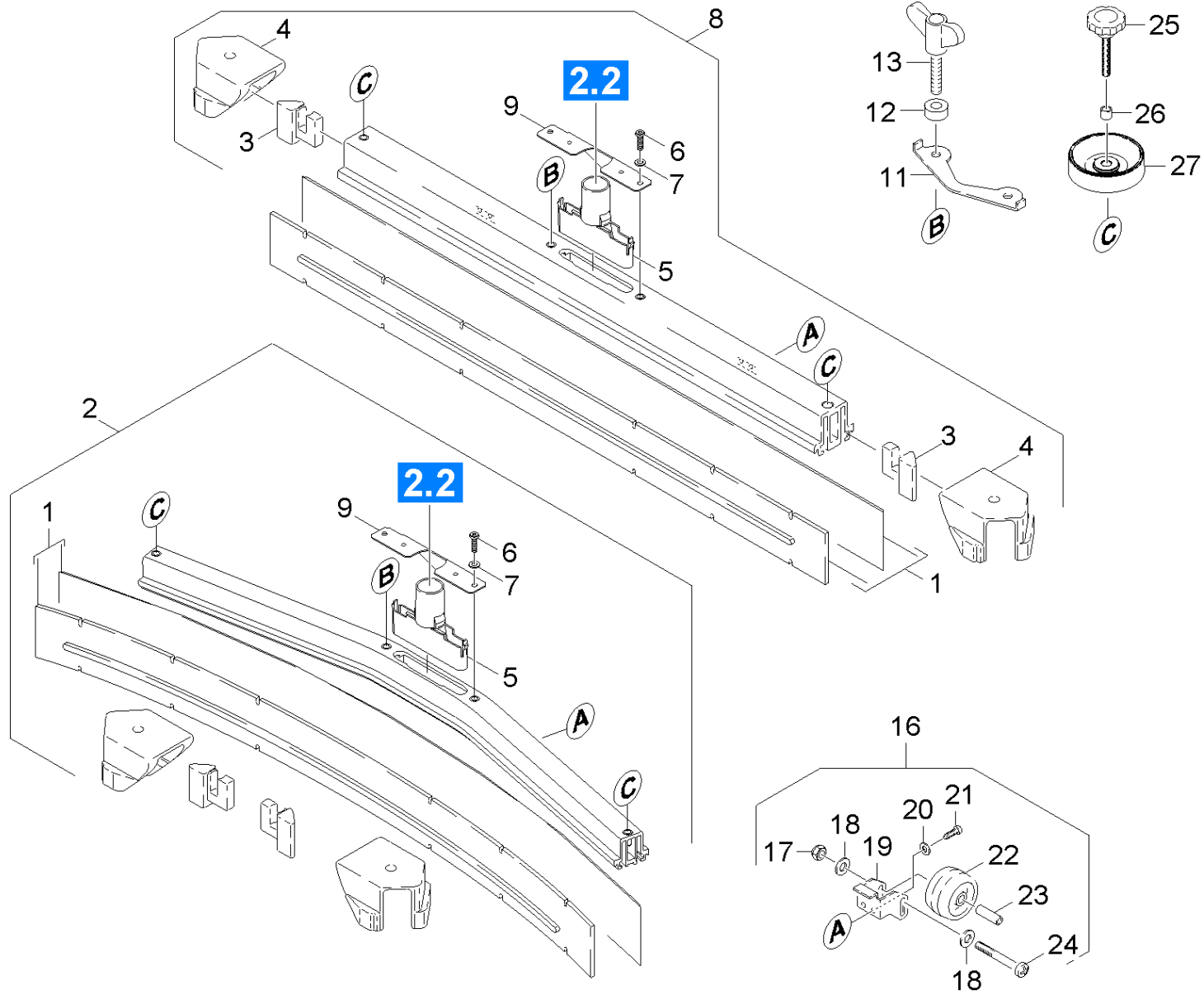

52 Suction bar (0.164-832.0)

ET/VT (spare/wear parts)	Pos	Material #	Name	Qty.	Unit	from ser.nr.	up to ser.nr.	var. information	Footnote text
X-X	1	6.273-214.0	Rubber lip set standard	1.000	ZSA			BR/BD 75/140	STANDARD
X-X	1	6.273-205.0	Rubber lip set anti stripe oil resistant	1.000	ZSA			BR/BD 75/140	ANTI-STRIP
X-X	1	6.273-209.0	Rubber lip set oil resistant	1.000	ZSA			BR/BD 90/140	OIL RESISTANT
X-X	1	6.273-215.0	Rubber lip set standard	1.000	ZSA			BR/BD 90/140	STANDARD
X-X	1	6.273-208.0	Rubber lip set oil resistant	1.000	ZSA	0000000000	0000000000	BR/BD 75/140	OIL RESISTANT
X-X	1	6.273-206.0	Rubber lip set anti stripe oil resistant	1.000	ZSA			BR/BD 90/140	ANTI-STRIP
X-X	2	4.777-312.0	Suction bar curved 940AB	1.000	ST	0000000000	0000000000	BR/BD 75/140	
X-X	2	4.777-313.0	Suction bar curved 1060AB	1.000	ST			BR/BD 90/140	
X-X	3	2.885-326.0	End piece left / right spare parts set	1.000	ST	0000000000	0000000000		
X-X	4	2.885-294.0	End piece left / right spare parts set	1.000	ST	0000000000	0000000000		
X-X	5	5.033-601.0	Suction nipple	1.000	ST				GREY
X-X	6	7.306-142.0	Cylinder head screw M 8x25-A4-70 ISO 47	2.000	ST				
X-X	7	7.312-017.0	Washer 8-A2 ISO 7089	2.000	ST				
X-X	8	4.777-303.0	Suction bar 1060AB	1.000	ST			BR/BD 90/140	
X-X	8	4.777-302.0	Suction bar 940AB	1.000	ST	0000000000	0000000000	BR/BD 75/140	
X-X	9	5.100-559.0	Suction bar support plate	1.000	ST				
X-X	11	5.007-217.0	Plate	1.000	ST	0000000000	0000000000		
X-X	12	5.112-810.0	Sleeve VA	2.000	ST			( VA )	
X-X	13	5.305-296.0	Wing screw M8x40 VA	2.000	ST			( VA )	
X-X	16	2.639-561.0	Add-on kit support wheels suction bar	1.000	ST	0000000000	0000000000		
X-X	17	7.311-422.0	Hexagon nut M 6-1.4305 ISO 10511	1.000	ST	0000000000	0000000000		
X-X	18	7.312-026.0	Washer 6 -A2 ISO 7090	2.000	ST	0000000000	0000000000		
	19	5.044-304.0	Holder roller	2.000	ST	0000000000	0000000000		
	20	7.312-052.0	Washer 5 -A2 ISO 7089	2.000	ST	0000000000	0000000000		
X-X	21	7.303-037.0	Screw M5x10 -St-P2R (In6Rd)	2.000	ST	0000000000	0000000000		

**52 Suction bar (0.164-832.0)**

ET/VT (spare/wear parts)	Pos	Material #	Name	Qty.	Unit	from ser.nr.	up to ser.nr.	var. information	Footnote text
X-X	22	6.435-401.0	Wheel D54	2.000	ST	0000000000	0000000000		
X-X	23	5.105-245.0	Axle	1.000	ST	0000000000	0000000000		
	24	7.304-550.0	Hexagonal head screw M 6x45-A4-70 ISO 4	2.000	ST				
X-X	25	6.321-239.0	Star grip VA Ø50x43	2.000	ST				STAINLESS STEEL CONSTRUCTION
X-X	26	5.094-231.0	Sleeve suction bar in VA	2.000	ST				STAINLESS STEEL CONSTRUCTION
X-X	27	5.515-267.0	Deflector roll suction bar	2.000	ST				

Suction bar curved 940AB (4.777-312.0)

---

Material #	Name	DOC	from ser.nr.	up to ser.nr.
5.960-139.0	Operating manual instruction sheet	BTA-1000774-000-06.pdf	0000000000	0000000000
Position text: 47770550				
5.971-951.0	Spare parts list suction bar curved 940A			

Spare parts list suction bar curved 940A (5.971-951.0)

---

Pos	Name	Qty.	Unit
10	Suction bar curved 940mm	1.000	ST

---

Suction bar 940AB (4.777-302.0)

---

Material #	Name	DOC	from ser.nr.	up to ser.nr.
5.960-139.0	Operating manual instruction sheet	BTA-1000774-000-06.pdf	0000000000	0000000000
Position text: 47770490				
5.971-949.0	Spare parts list suction bar 940AB			

Spare parts list suction bar 940AB (5.971-949.0)

---

Pos	Name	Qty.	Unit
10	Suction bar straight 940mm	1.000	ST

---

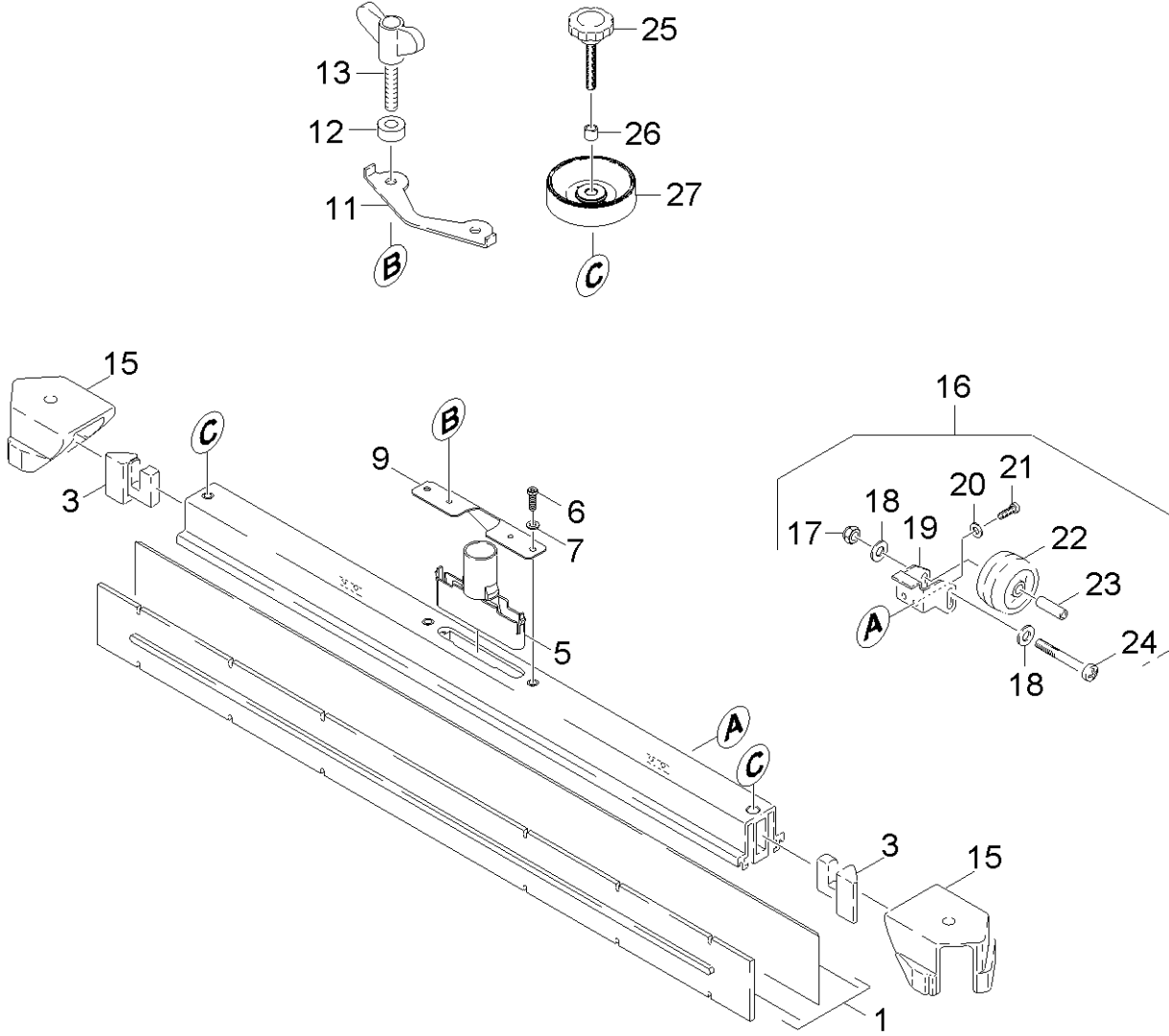



10 Suction bar straight 940mm (0.166-280.0)

ET/VT (spare/wear parts)	Pos	Material #	Name	Qty.	Unit	from ser.nr.	up to ser.nr.	var. information	Footnote text
X-X	1	6.273-205.0	Rubber lip set anti stripe oil resistant	1.000	ZSA				ANTI-STRIP, OIL RESISTANT
X-X	1	6.273-214.0	Rubber lip set standard	1.000	ZSA				STANDARD
X-X	1	6.273-208.0	Rubber lip set oil resistant	1.000	ZSA	0000000000	0000000000		OIL RESISTANT
X-X	3	2.885-326.0	End piece left / right spare parts set	1.000	ST	0000000000	0000000000		
X-X	5	5.033-601.0	Suction nipple	1.000	ST				GREY
X-X	6	7.306-142.0	Cylinder head screw M 8x25-A4-70 ISO 47	2.000	ST				
X-X	7	7.312-017.0	Washer 8-A2 ISO 7089	2.000	ST				
X-X	9	5.100-559.0	Suction bar support plate	1.000	ST				
X-X	11	5.007-217.0	Plate	1.000	ST	0000000000	0000000000		
X-X	12	5.112-810.0	Sleeve VA	2.000	ST			( VA )	
X-X	13	5.305-296.0	Wing screw M8x40 VA	2.000	ST			( VA )	
X-X	15	2.885-294.0	End piece left / right spare parts set	1.000	ST	0000000000	0000000000		
X-X	16	2.639-561.0	Add-on kit support wheels suction bar	1.000	ST	0000000000	0000000000		
X-X	17	7.311-422.0	Hexagon nut M 6-1.4305 ISO 10511	1.000	ST	0000000000	0000000000		
X-X	18	7.312-026.0	Washer 6 -A2 ISO 7090	2.000	ST	0000000000	0000000000		
	19	5.044-304.0	Holder roller	2.000	ST	0000000000	0000000000		
	20	7.312-052.0	Washer 5 -A2 ISO 7089	2.000	ST	0000000000	0000000000		
X-X	21	7.303-037.0	Screw M5x10 -St-P2R (In6Rd)	2.000	ST	0000000000	0000000000		
X-X	22	6.435-401.0	Wheel D54	2.000	ST	0000000000	0000000000		
X-X	23	5.105-245.0	Axle	1.000	ST	0000000000	0000000000		
	24	7.304-550.0	Hexagonal head screw M 6x45-A4-70 ISO 4	2.000	ST				
X-X	25	6.321-239.0	Star grip VA Ø50x43	2.000	ST				STAINLESS STEEL CONSTRUCTION
X-X	26	5.094-231.0	Sleeve suction bar in VA	2.000	ST				STAINLESS STEEL CONSTRUCTION
X-X	27	5.515-267.0	Deflector roll suction bar	2.000	ST				

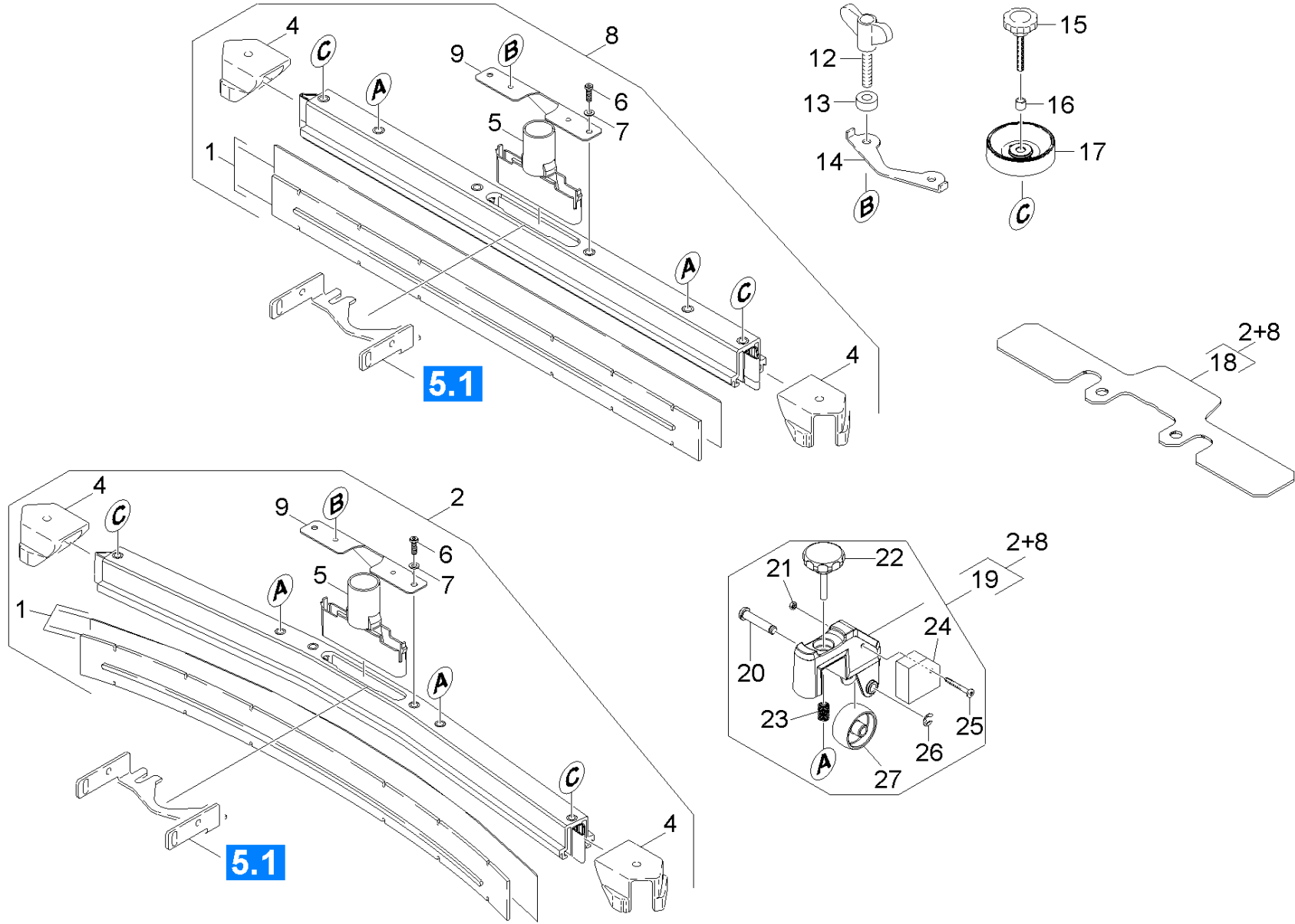

53 Suction bar (0.110-242.0)

ET/VT (spare/wear parts)	Pos	Material #	Name	Qty.	Unit	var. information	Footnote text
X-X	1	6.273-215.0	Rubber lip set standard	1.000	ZSA	(1060mm)	STANDARD
X-X	1	6.273-291.0	BLADES FOR TEXTURED FLOORS	1.000	ST	(980mm)	CLOSED, OIL RESISTANT
X-X	1	6.273-293.0	BLADES FOR TEXTURED FLOORS	1.000	ST	(1100mm)	CLOSED, OIL RESISTANT
X-X	1	6.273-205.0	Rubber lip set anti stripe oil resistant	1.000	ZSA	(940mm)	ANTI-STRIP, OIL RESISTANT
X-X	1	6.273-214.0	Rubber lip set standard	1.000	ZSA	(940mm)	STANDARD
X-X	1	6.273-206.0	Rubber lip set anti stripe oil resistant	1.000	ZSA	(1060mm)	ANTI-STRIP, OIL RESISTANT
X-X	1	6.273-208.0	Rubber lip set oil resistant	1.000	ZSA	(940mm)	OIL RESISTANT
X-X	1	6.273-209.0	Rubber lip set oil resistant	1.000	ZSA	(1060mm)	OIL RESISTANT
X-X	2	4.777-413.0	Suction bar curved 1060mm	1.000	ST	(1060mm)	
X-X	2	4.777-412.0	Suction bar curved 940mm	1.000	ST	(940mm)	
X-X	4	2.885-294.0	End piece left / right spare parts set	1.000	ST		
X-X	5	5.033-601.0	Suction nipple	1.000	ST		
X-X	6	7.306-142.0	Cylinder head screw M 8x25-A4-70 ISO 47	2.000	ST		
X-X	7	7.312-017.0	Washer 8-A2 ISO 7089	2.000	ST		
X-X	8	4.777-403.0	Suction bar straight 1060mm	1.000	ST	(1060mm)	
X-X	8	4.777-402.0	Suction bar straight 940mm	1.000	ST	(940mm)	
X-X	9	5.100-559.0	Suction bar support plate	1.000	ST		
X-X	12	5.305-296.0	Wing screw M8x40 VA	2.000	ST		
X-X	13	5.112-810.0	Sleeve VA	2.000	ST		
X-X	14	5.007-217.0	Plate	2.000	ST		
X-X	15	6.321-239.0	Star grip VA Ø50x43	2.000	ST		
X-X	16	5.094-231.0	Sleeve suction bar in VA	2.000	ST		
X-X	17	5.515-346.0	Deflector roll suction bar D120	2.000	ST		
X-X	18	5.128-339.0	Additional weight suction bar	1.000	ST		
X-X	19	4.035-339.0	Roller suction bar	2.000	ST		

**53 Suction bar (0.110-242.0)**

ET/VT (spare/wear parts)	Pos	Material #	Name	Qty.	Unit	var. information	Footnote text
X	20	5.304-098.0	Bolt	2.000	ST		
X-X	21	7.311-431.0	Hexagon nut M 5-1.4305 ISO 10511	2.000	ST		
X-X	22	6.321-240.0	Star grip with inscription VA Ø50x43	2.000	ST		
X-X	23	5.332-504.0	Pressure spring	2.000	ST		
	24	5.100-560.0	Additional weight suction bar 300 g	2.000	ST		
X-X	25	7.306-185.0	Screw M5x 35-A2-70 (IN6RD)	2.000	ST		
X-X	26	7.343-303.0	Locking ring 8-A2 DIN 6799	2.000	ST		
X-X	27	6.435-401.0	Wheel D54	2.000	ST		

Suction bar curved 940mm (4.777-412.0)

---

Material #	Name	DOC	from ser.nr.	up to ser.nr.
5.960-139.0	Operating manual instruction sheet	BTA-1000774-000-06.pdf	0000000000	0000000000
Position text: 47770550				
5.971-897.0	Spare parts list suction bar curved 940m			

Spare parts list suction bar curved 940m (5.971-897.0)

---

Pos	Name	Qty.	Unit
10	Suction bar curved 940mm	1.000	ST

---

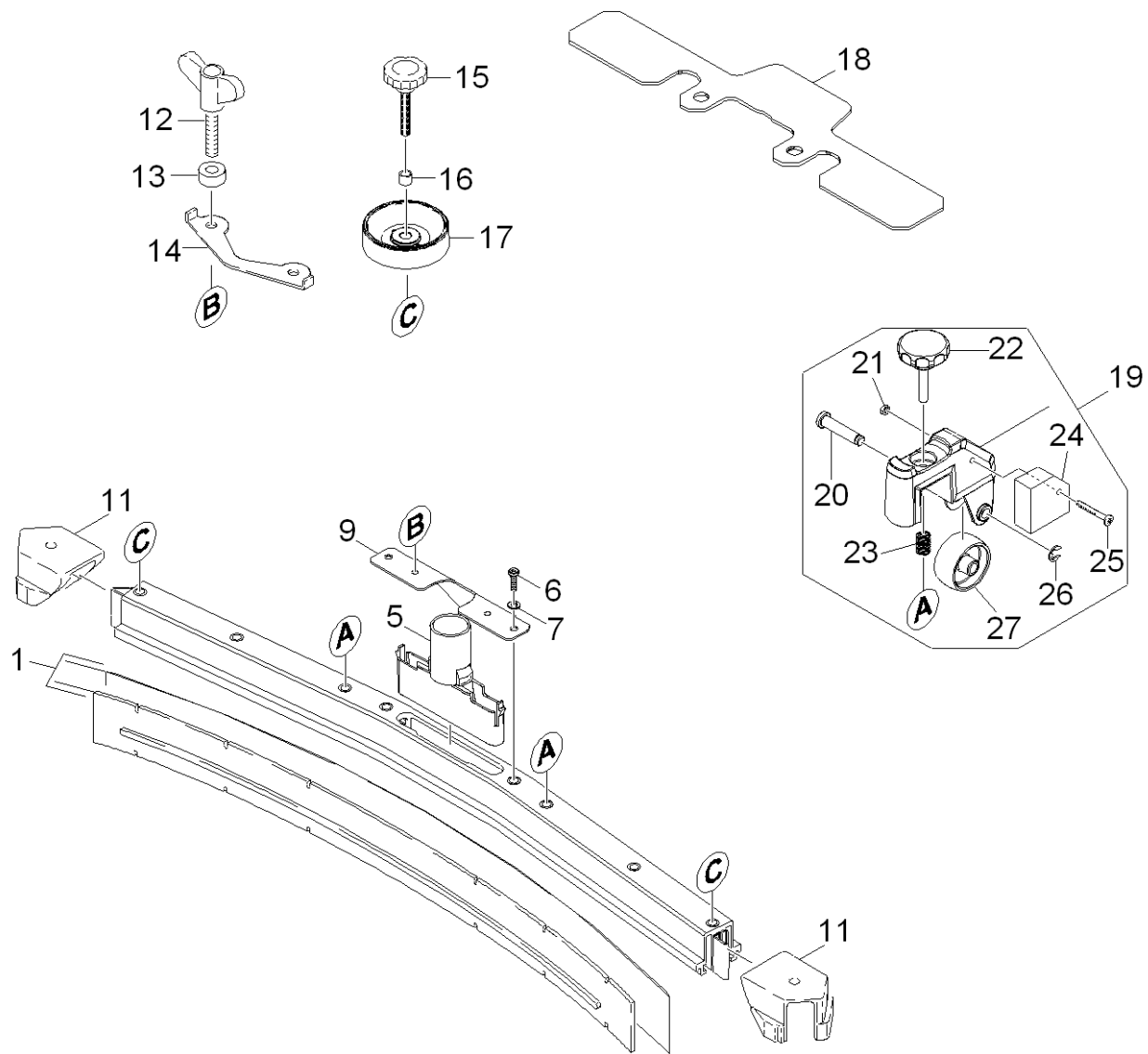

10 Suction bar curved 940mm (0.166-279.0)

ET/VT (spare/wear parts)	Pos	Material #	Name	Qty.	Unit	var. information	Footnote text
X-X	1	6.273-205.0	Rubber lip set anti stripe oil resistant	1.000	ZSA	(890mm)	OIL RESISTANT
X-X	1	6.273-214.0	Rubber lip set standard	1.000	ZSA	(890mm)	CLOSED, OIL RESISTANT
X-X	1	6.273-291.0	BLADES FOR TEXTURED FLOORS	1.000	ST	(890mm)	ANTI-STRIP, OIL RESISTANT
X-X	1	6.273-208.0	Rubber lip set oil resistant	1.000	ZSA		
X-X	5	5.033-601.0	Suction nipple	1.000	ST		
X-X	6	7.306-142.0	Cylinder head screw M 8x25-A4-70 ISO 47	2.000	ST		
X-X	7	7.312-017.0	Washer 8-A2 ISO 7089	2.000	ST		
X-X	9	5.100-559.0	Suction bar support plate	1.000	ST		
X-X	11	2.885-294.0	End piece left / right spare parts set	1.000	ST		
X-X	12	5.305-296.0	Wing screw M8x40 VA	2.000	ST		
X-X	13	5.112-810.0	Sleeve VA	2.000	ST		
X-X	14	5.007-217.0	Plate	2.000	ST		
X-X	15	6.321-239.0	Star grip VA Ø50x43	2.000	ST		
X-X	16	5.094-231.0	Sleeve suction bar in VA	2.000	ST		
X-X	17	5.515-346.0	Deflector roll suction bar D120	2.000	ST		
X-X	18	5.128-339.0	Additional weight suction bar	1.000	ST		
X-X	19	4.035-339.0	Roller suction bar	2.000	ST		
X	20	5.304-098.0	Bolt	2.000	ST		
X-X	21	7.311-431.0	Hexagon nut M 5-1.4305 ISO 10511	2.000	ST		
X-X	22	6.321-240.0	Star grip with inscription VA Ø50x43	2.000	ST		
X-X	23	5.332-504.0	Pressure spring	2.000	ST		
	24	5.100-560.0	Additional weight suction bar 300 g	2.000	ST		
X-X	25	7.306-185.0	Screw M5x 35-A2-70 (IN6RD)	2.000	ST		
X-X	26	7.343-303.0	Locking ring 8-A2 DIN 6799	2.000	ST		
X-X	27	6.435-401.0	Wheel D54	2.000	ST		



Suction bar straight 940mm (4.777-402.0)

---

Material #	Name	DOC	from ser.nr.	up to ser.nr.
5.960-139.0	Operating manual instruction sheet	BTA-1000774-000-06.pdf	0000000000	0000000000
Position text: 47770490				
5.971-896.0	Spare parts list suction bar straight 94			

Spare parts list suction bar straight 94 (5.971-896.0)

---

Pos	Name	Qty.	Unit
10	Suction bar straight 940mm	1.000	ST

---

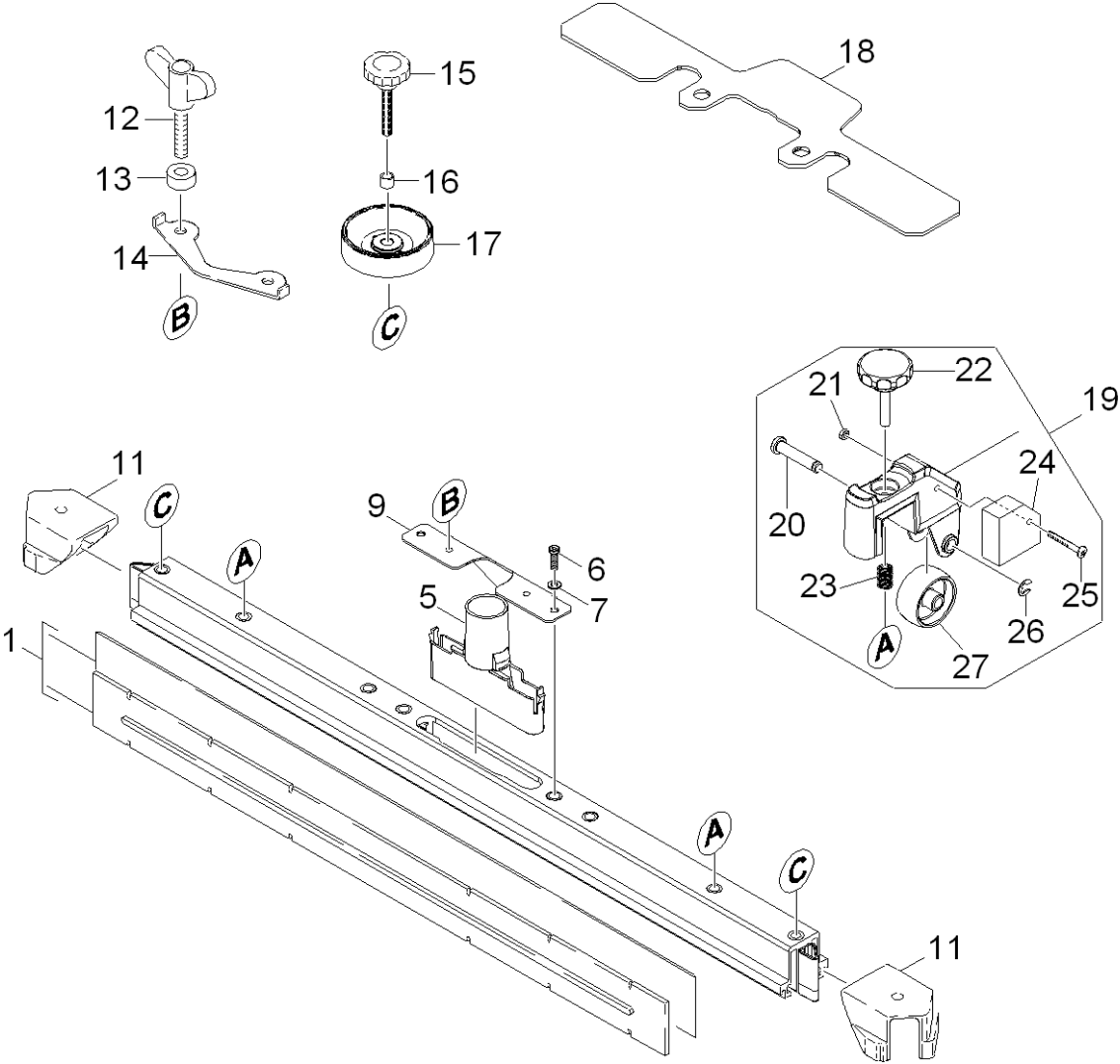

10 Suction bar straight 940mm (0.166-278.0)

ET/VT (spare/wear parts)	Pos	Material #	Name	Qty.	Unit	var. information	Footnote text
X-X	1	6.273-205.0	Rubber lip set anti stripe oil resistant	1.000	ZSA	(890mm)	OIL RESISTANT
X-X	1	6.273-214.0	Rubber lip set standard	1.000	ZSA	(890mm)	CLOSED, OIL RESISTANT
X-X	1	6.273-291.0	BLADES FOR TEXTURED FLOORS	1.000	ST	(890mm)	ANTI-STRIP, OIL RESISTANT
X-X	1	6.273-208.0	Rubber lip set oil resistant	1.000	ZSA		
X-X	5	5.033-601.0	Suction nipple	1.000	ST		
X-X	6	7.306-142.0	Cylinder head screw M 8x25-A4-70 ISO 47	2.000	ST		
X-X	7	7.312-017.0	Washer 8-A2 ISO 7089	2.000	ST		
X-X	9	5.100-559.0	Suction bar support plate	1.000	ST		
X-X	11	2.885-294.0	End piece left / right spare parts set	1.000	ST		
X-X	12	5.305-296.0	Wing screw M8x40 VA	2.000	ST		
X-X	13	5.112-810.0	Sleeve VA	2.000	ST		
X-X	14	5.007-217.0	Plate	2.000	ST		
X-X	15	6.321-239.0	Star grip VA Ø50x43	2.000	ST		
X-X	16	5.094-231.0	Sleeve suction bar in VA	2.000	ST		
X-X	17	5.515-346.0	Deflector roll suction bar D120	2.000	ST		
X-X	18	5.128-339.0	Additional weight suction bar	1.000	ST		
X-X	19	4.035-339.0	Roller suction bar	2.000	ST		
X	20	5.304-098.0	Bolt	2.000	ST		
X-X	21	7.311-431.0	Hexagon nut M 5-1.4305 ISO 10511	2.000	ST		
X-X	22	6.321-240.0	Star grip with inscription VA Ø50x43	2.000	ST		
X-X	23	5.332-504.0	Pressure spring	2.000	ST		
	24	5.100-560.0	Additional weight suction bar 300 g	2.000	ST		
X-X	25	7.306-185.0	Screw M5x 35-A2-70 (IN6RD)	2.000	ST		
X-X	26	7.343-303.0	Locking ring 8-A2 DIN 6799	2.000	ST		
X-X	27	6.435-401.0	Wheel D54	2.000	ST		

60 POWER BRUSH (0.165-270.0)

---

Pos	Name	Qty.	Unit
61	Power brush BR	1.000	ST
62	Roll pad BR	1.000	ST
63	Power brush BD	1.000	ST
64	ELEVATING MECHANISM	1.000	ST
65	Add-on kit side strip stiffener	1.000	ST

---

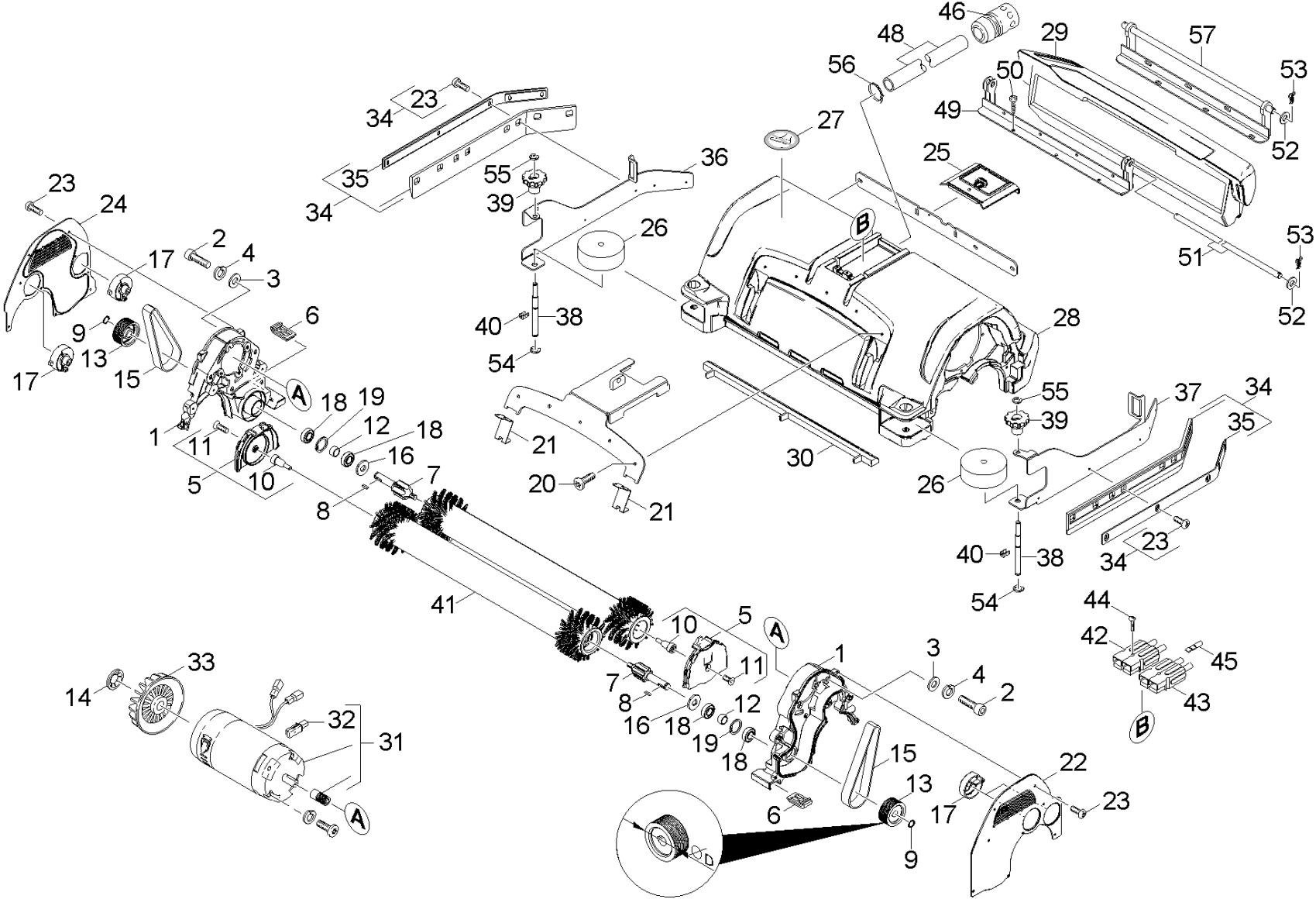

61 Power brush BR (0.165-276.0)

ET/VT (spare/wear parts)	Pos	Material #	Name	Qty.	Unit	var. information	Footnote text
X-X	1	5.044-866.0	Retainer plate transmission	2.000	ST	5.625-494.0	
X-X	1	2.882-726.0	Conversion kit retainer plate transmissi	2.000	ST	5.625-483.0	
X-X	2	7.306-031.0	Screw M 6x16-A2-70 DIN 7984	10.000	ST		
X-X	3	7.312-026.0	Washer 6 -A2 ISO 7090	10.000	ST		
X	4	7.313-003.0	Spring washer B 6-FSt-A3E DIN 127	10.000	ST		
X-X	5	2.763-032.0	Set holder-up replacement	2.000	ST		
X-X	6	5.056-010.0	Rocker BR-VS	2.000	ST		
X-X	7	5.100-611.0	Driveshaft BR	2.000	ST		VERSION 2
X-X	7	5.100-553.0	Driveshaft BR 65 / 90	2.000	ST		VERSION 1
X-X	8	7.318-002.0	Parallel key 5x5x16 -C45R DIN 6885-1	2.000	ST		
X-X	9	7.343-015.0	Locking ring 15x1-FST-RF DIN 471	2.000	ST		
X-X	10	5.116-340.0	Bolt holder-up	2.000	ST		
X-X	11	7.305-637.0	Countersunk screw M8x16-A2-70 ISO 10642	2.000	ST		
X-X	12	5.116-354.0	Bush transmission BR	2.000	ST		VERSION 1
X-X	12	5.116-413.0	Sleeve	2.000	ST		VERSION 2
X-X	13	5.625-483.0	Belt pulley 57mm	2.000	ST	D = 57mm	VERSION 1
X-X	13	5.625-494.0	Belt pulley 54mm	2.000	ST	D = 54mm	VERSION 2
	14	6.343-149.0	Quick-fastener	2.000	ST		
X-X	15	6.348-442.0	Ribbed v-belt	2.000	ST		VERSION 1
X-X	15	6.348-456.0	Ribbed v-belt	2.000	ST		VERSION 2
X-X	16	6.363-158.0	Joint ring Nilosring	2.000	ST		
X-X	17	5.033-206.0	Locking part	4.000	ST		YELLOW
X-X	17	5.033-665.0	Locking part	4.000	ST		GREY
	18	7.401-128.0	Ball bearing 6202-2RS -Wälzl.St DIN 625	4.000	ST		VERSION 2
X-X	18	7.401-115.0	Ball bearing 6002-2RS -WÄELZLAGST DIN 62	4.000	ST		VERSION 1

**61 Power brush BR (0.165-276.0)**

ET/VT (spare/wear parts)	Pos	Material #	Name	Qty.	Unit	var. information	Footnote text
X-X	19	7.343-017.0	Locking ring 35x1,5-FST-PHR DIN 472	2.000	ST		VERSION 2
X-X	19	7.343-231.0	Locking ring 32x1,2 -St-ph DIN 472	2.000	ST		VERSION 1
	20	7.303-047.0	Screw M6x16 -St-R3R (In6Rd)	5.000	ST		
X-X	21	5.033-664.0	Locking part tension rod	2.000	ST		GREY
X-X	21	5.033-394.0	Locking part	2.000	ST		YELLOW
X-X	22	5.033-241.0	Covering cap left	1.000	ST		
X-X	23	7.303-037.0	Screw M5x10 -St-P2R (In6Rd)	28.000	ST		
X-X	24	5.033-242.0	Covering cap right	1.000	ST		
X	25	5.033-403.0	Cover BR	1.000	ST		
X-X	26	5.515-096.0	Roller	2.000	ST		
	27	5.383-097.0	Label	1.000	ST		
X-X	28	5.061-983.0	Brush housing R 90	1.000	ST		
	28	5.061-577.0	Brush housing BR 75	1.000	ST		
	29	5.075-042.0	Tank refuse BR 90	1.000	ST		
	29	5.075-041.0	Tank refuse BR 75	1.000	ST		
X-X	30	5.190-261.0	Strip water distributor	1.000	ST	R 65	GREY
X-X	30	5.190-291.0	Strip water distributor R 90	1.000	ST	R 90	YELLOW
X-X	30	5.190-291.0	Strip water distributor R 90	1.000	ST	R 90	GREY
X-X	30	5.190-261.0	Strip water distributor	1.000	ST	R 65	YELLOW
	31	4.623-993.0	Motor complete	2.000	ST	24V//600W	VERSION 2
X-X	31	4.623-920.0	Motor complete nur fuer Ersatz	2.000	ST	24V//600W	VERSION 1
	31	4.623-927.0	Motor complete only for replacement	2.000	ST	24V//750W	
X-X	32	6.610-239.0	Carbon brush set ATAS	1.000	ST	(ATAS)	
X-X	32	6.610-216.0	Carbon brush set	1.000	ZSA	(AMER)	
X-X	33	6.613-025.0	Blower wheel	2.000	ST		



61 Power brush BR (0.165-276.0)

ET/VT (spare/wear parts)	Pos	Material #	Name	Qty.	Unit	var. information	Footnote text
X-X	34	4.071-228.0	Set splash guard onesided	2.000	ST		
X-X	35	5.044-867.0	Retainer strip splash guard	2.000	ST		
X-X	36	5.009-401.0	Bracket right scraper lip	1.000	ST		
X-X	37	5.009-402.0	Bracket left scraper lip	1.000	ST		
X-X	38	5.116-339.0	Threaded bolt	2.000	ST		
X-X	39	5.033-666.0	Hand wheel	2.000	ST		
X-X	40	6.330-407.0	Spring clip	2.000	ST		
X-X	41	6.906-992.0	Roller brush black - BR 90	2.000	ST		
X	41	6.907-415.0	Roller brush red BR 75	2.000	ST		
X-X	41	6.907-377.0	Roller brush red BR 90	2.000	ST		
X-X	41	6.906-991.0	Roller brush green - BR 90	2.000	ST		
X-X	41	6.906-986.0	Roller brush orange - BR 75	2.000	ST		
X-X	41	6.906-985.0	Roller brush white - BR 75	2.000	ST		
X-X	41	4.114-008.0	Microfibre roll complete BR 90	2.000	ST		
X-X	41	4.114-007.0	Microfibre roll complete BR 75	2.000	ST		
X-X	41	6.906-987.0	Roller brush green - BR 75	2.000	ST		
X-X	41	6.906-988.0	Roller brush black - BR 75	2.000	ST		
X-X	41	6.906-989.0	Roller brush white - BR 90	2.000	ST		
X-X	41	6.906-990.0	Roller brush orange - BR 90	2.000	ST		
X-X	42	6.646-329.0	Plug red 75A	2.000	ST		
X-X	43	6.646-330.0	Plug blue 75A	2.000	ST		
X-X	44	7.303-107.0	Screw 5x16 -10.9-P2R (K-In6Rd)	3.000	ST		
X-X	45	6.646-979.0	Switch contact	4.000	ST		
	46	6.388-482.0	Hose coupling	1.000	ST		
X-X	48	6.390-892.0	Spiral hose NW12	1.000	M		TO ORDER AS CUT GOODS

**61 Power brush BR (0.165-276.0)**

ET/VT (spare/wear parts)	Pos	Material #	Name	Qty.	Unit	var. information	Footnote text
	49	4.481-239.0	Holder brush-head	1.000	ST		
X-X	50	7.303-112.0	Screw 6x20 -10.9-R2R (In6Rd)	6.000	ST		
X	51	5.107-290.0	Bar brush-head	1.000	ST		
	52	7.312-008.0	Washer 12-200HV-A3E ISO 7090	2.000	ST		
X-X	53	6.313-022.0	Spring clip	2.000	ST		
X-X	54	7.343-047.0	Lock washer 10-FST-A2E DIN 6799	2.000	ST		
X-X	55	7.343-302.0	Lock washer 8 -St-ph DIN 6799	2.000	ST		
X-X	56	6.388-545.0	Hose clip	1.000	ST		
	57	4.481-261.0	Holder pivot point complete BR	1.000	ST		

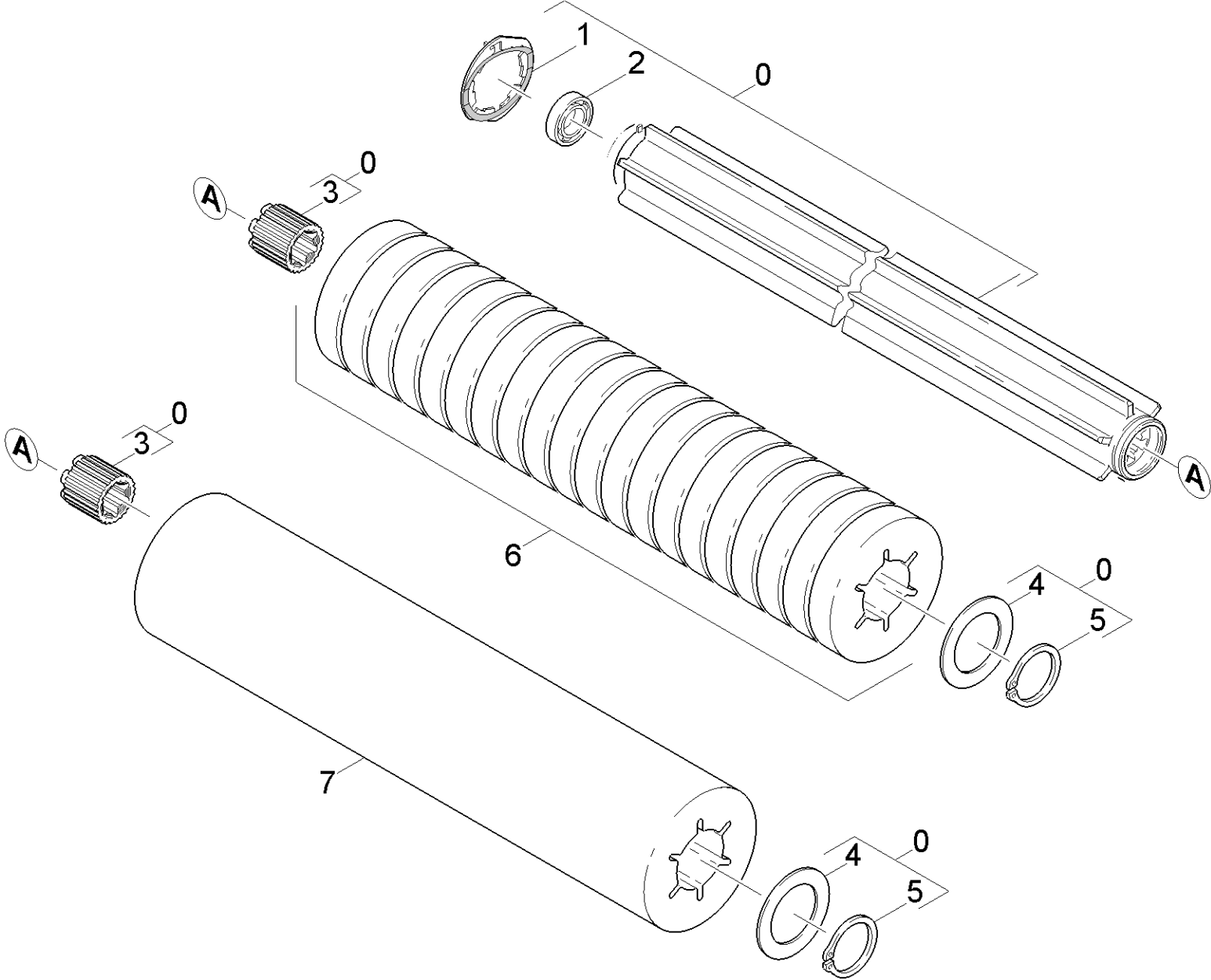

62 Roll pad BR (0.165-274.0)

ET/VT (spare/wear parts)	Pos	Material #	Name	Qty.	Unit
X-X	0	4.762-435.0	Roll pad BR 90	2.000	ST
X-X	0	4.762-434.0	Roll pad BR 75	2.000	ST
X-X	1	4.115-004.0	Washer closure	1.000	ST
X-X	2	7.401-005.0	Ball bearing 6302-2RS- DIN 6	1.000	ST
	3	5.112-823.0	Bush Torx	2.000	ST
	4	5.005-267.0	Ronde	1.000	ST
X-X	5	7.343-037.0	Locking ring 50x2-FST-RF DIN 471	1.000	ST
X-X	6	6.369-456.0	Pad red 105-20ST	2.000	ZSA
X-X	6	6.369-389.0	Pad white 105-20ST	2.000	ZSA
X-X	6	6.369-455.0	Pad green 105-20ST	2.000	ZSA
X-X	6	6.369-454.0	Pad yellow 105-20ST	2.000	ZSA
X-X	7	4.114-008.0	Microfibre roll complete BR 90	2.000	ST
X-X	7	4.114-007.0	Microfibre roll complete BR 75	2.000	ST

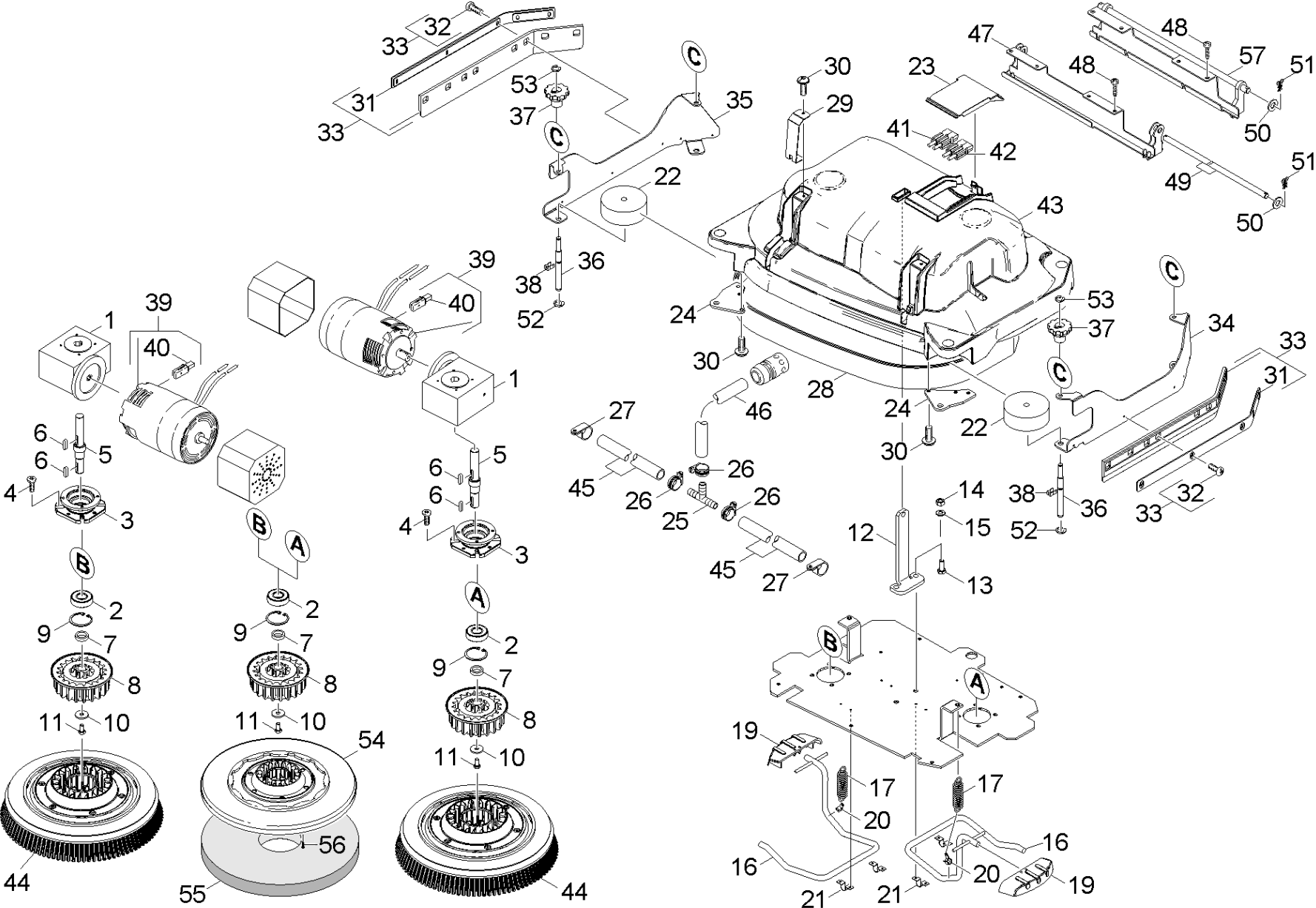

## 63 Power brush BD (0.165-271.0)

ET/VT (spare/wear parts)	Pos	Material #	Name	Qty.	Unit	var. information	Footnote text
X-X	1	6.454-198.0	Worm gearing i=20	2.000	ST		
X-X	2	7.401-173.0	Ball bearing 6204-2RS-WAELZLAGST DIN 625	2.000	ST		
X-X	3	5.122-470.0	Flange worked	2.000	ST		
	4	7.303-067.0	Screw M8x16-ST-A3R (IN6RD)	8.000	ST		
X	5	5.100-566.0	Shaft	2.000	ST		
X-X	6	7.318-030.0	Parallel key 6x6x25 -C45R DIN 6885-1	4.000	ST		
X	7	5.116-359.0	Sleeve	2.000	ST		
X-X	8	5.122-462.0	Retainer transmission die casting	2.000	ST		
X-X	9	7.343-115.0	Locking ring 47x1,75 -St-ph DIN 472	2.000	ST		
X-X	10	7.312-268.0	Washer 8 -A2 ISO 7094	2.000	ST		
X-X	11	7.304-538.0	Hexagonal head screw M8x16-A4-70 ISO 40	2.000	ST		
	12	5.009-666.0	Plate suspension	1.000	ST		
X-X	13	7.304-801.0	Hexagonal head screw M10x25-A4-70 ISO 4	2.000	ST		
X-X	14	7.311-066.0	Hexagon nut M10-A2-70 ISO 4032	2.000	ST		
X-X	15	7.312-066.0	Washer 10 -A2 ISO 7090	2.000	ST		
	16	4.058-162.0	Lever complete BD 75	2.000	ST		
X-X	16	4.058-161.0	Lever complete BD 55+65	2.000	ST		
X-X	17	6.330-093.0	Extension spring	2.000	ST		
X-X	19	5.481-370.0	Pedal lever notch	2.000	ST		YELLOW
	19	5.481-431.0	Pedal lever notch	2.000	ST		GREY
X-X	20	6.388-559.0	Hose clip	2.000	ST		
X-X	21	6.373-689.0	Pipe clamp	4.000	ST		
X-X	22	5.515-326.0	Roller	2.000	ST		
X-X	23	5.033-400.0	Cover BD	1.000	ST		
X-X	24	5.009-662.0	Bracket deflector roll	2.000	ST		

63 Power brush BD (0.165-271.0)

ET/VT (spare/wear parts)	Pos	Material #	Name	Qty.	Unit	var. information	Footnote text
X-X	25	6.388-408.0	T-Hose nozzle 1/2"	1.000	ST		
	26	6.388-546.0	Hose clip	3.000	ST		
	27	6.641-460.0	Cable clamp	2.000	ST		
	28	5.365-311.0	Sealing profile	1.000	ST	BD 75	
X	28	5.365-319.0	Sealing profile	1.000	ST	BD 90	
X-X	29	5.009-660.0	Bracket tension rod	2.000	ST		YELLOW
X-X	29	5.062-277.0	Bracket tension rod	2.000	ST		GREY
X-X	30	7.303-113.0	Screw 6x25 -10.9-R2R (In6Rd)	8.000	ST		
X-X	31	5.044-867.0	Retainer strip splash guard	2.000	ST		
X-X	32	7.303-037.0	Screw M5x10 -St-P2R (In6Rd)	10.000	ST		
X-X	33	4.071-228.0	Set splash guard onesided	2.000	ST		
X-X	34	5.009-668.0	Bracket left scraper lip	1.000	ST		
X-X	35	5.009-667.0	Bracket right scraper lip	1.000	ST		
X-X	36	5.116-339.0	Threaded bolt	4.000	ST		
X-X	37	5.033-666.0	Hand wheel	4.000	ST		
X-X	38	6.330-407.0	Spring clip	4.000	ST		
	39	6.613-288.0	Direct current motor	2.000	ST		
X-X	40	6.610-216.0	Carbon brush set	1.000	ZSA	(AMER)	
X-X	40	6.610-239.0	Carbon brush set ATAS	1.000	ST	(ATAS)	
X-X	41	6.646-329.0	Plug red 75A	2.000	ST		
X-X	42	6.646-330.0	Plug blue 75A	2.000	ST		
X-X	43	5.064-269.0	Cover BD 750	1.000	ST		
X-X	43	5.064-308.0	Cover D 90	1.000	ST		
X-X	44	4.905-021.0	Disc brushes complete black BD75	2.000	ST		
	44	4.905-020.0	Disc brushes complete nature BD75	2.000	ST		

## 63 Power brush BD (0.165-271.0)

ET/VT (spare/wear parts)	Pos	Material #	Name	Qty.	Unit	var. information	Footnote text
X-X	44	4.905-005.0	Disc brushes complete white BD 45/40	2.000	ST		
X-X	44	4.905-004.0	Disc brushes complete nature BD 45/40	2.000	ST		
X-X	44	4.905-006.0	Disc brushes complete black BD 45/40	2.000	ST		
X-X	44	4.905-018.0	Disc brushes complete red BD75	2.000	ST		
X-X	44	4.905-003.0	Disc brush complete red 45	2.000	ST		
X-X	44	4.905-019.0	Disc brushes complete white BD75	2.000	ST		
X-X	45	6.388-248.0	Hose DN12,5	1.000	M		TO ORDER AS CUT GOODS
X-X	46	6.390-892.0	Spiral hose NW12	1.000	M		TO ORDER AS CUT GOODS
X-X	47	4.481-246.0	Holder pivot point head BD	1.000	ST		
X-X	48	7.303-112.0	Screw 6x20 -10.9-R2R (In6Rd)	4.000	ST		
X	49	5.107-290.0	Bar brush-head	1.000	ST		
	50	7.312-008.0	Washer 12-200HV-A3E ISO 7090	2.000	ST		
X-X	51	6.313-022.0	Spring clip	2.000	ST		
X-X	52	7.343-047.0	Lock washer 10-FST-A2E DIN 6799	4.000	ST		
X-X	53	7.343-302.0	Lock washer 8 -St-ph DIN 6799	4.000	ST		
X-X	54	4.762-493.0	Disk pad D 90	2.000	ST		
X-X	54	4.762-447.0	Disk pad BD 75	2.000	ST		
X	55	6.371-187.0	Diamond pad brown set 5x Ø380	2.000	ST		
	55	6.371-253.0	Diamond pad yellow set 5x Ø385	2.000	ST		
	55	6.371-252.0	Diamond pad white set 5x Ø385	2.000	ST		
X	55	6.371-194.0	Diamond pad violet set 5x Ø460	2.000	ST		
	55	6.371-193.0	Diamond pad brown set 5x Ø460	2.000	ST		
X	55	6.371-236.0	Diamond pad green set 5x Ø385	2.000	ST		
X	55	6.371-239.0	Diamond pad green set 5x Ø457	2.000	ST		
X	55	6.371-188.0	Diamond pad violet set 5x Ø380	2.000	ST		



63 Power brush BD (0.165-271.0)

---

ET/VT (spare/wear parts)	Pos	Material #	Name	Qty.	Unit	var. information	Footnote text
	56	7.303-096.0	Screw 4x22 -ST-10.9-R2R (IN6RD)	3.000	ST		

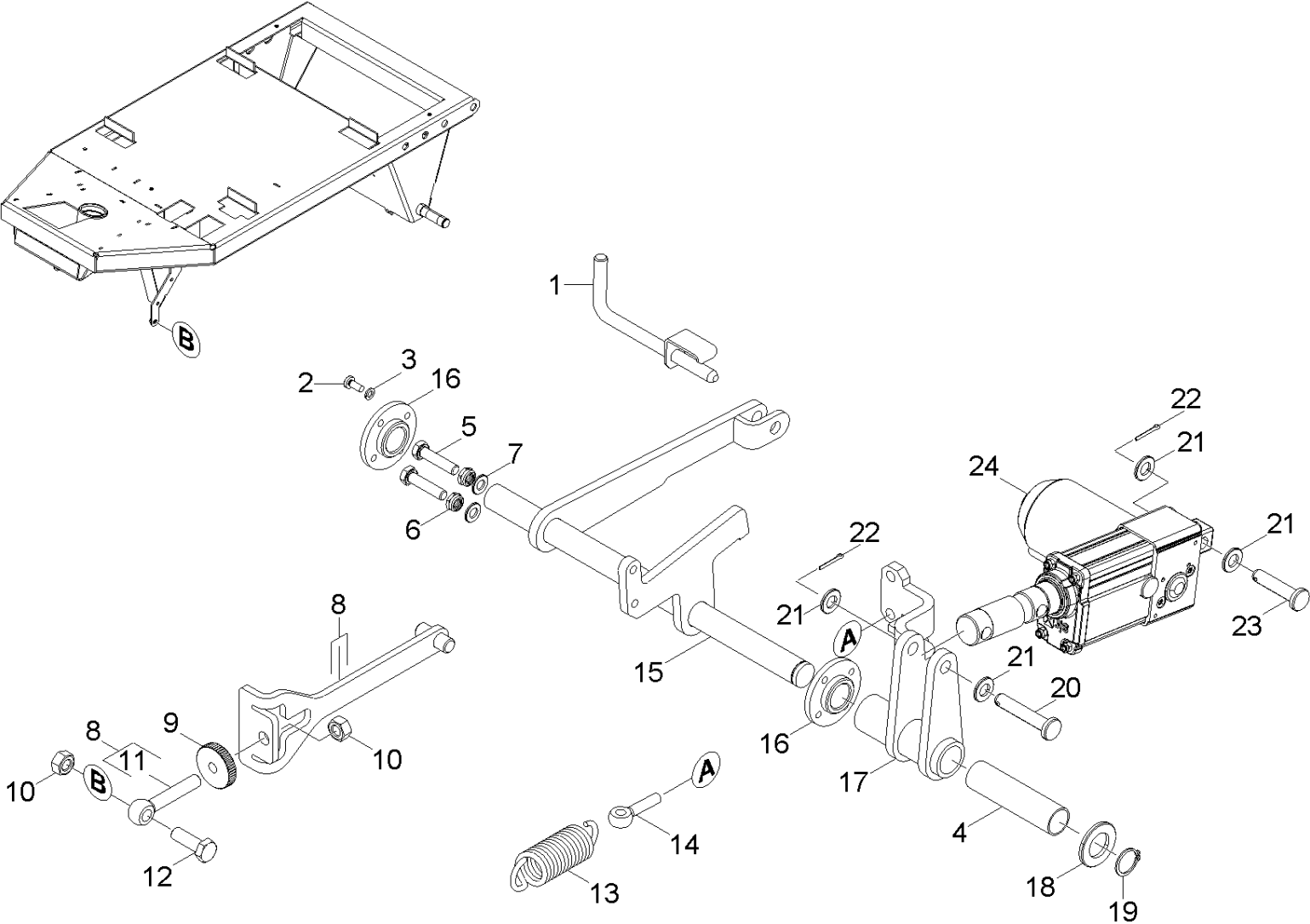

## 64 ELEVATING MECHANISM (0.165-275.0)

ET/VT (spare/wear parts)	Pos	Material #	Name	Qty.	Unit	var. information	Footnote text
X-X	1	4.481-243.0	Locking part	1.000	ST		
X-X	2	7.306-181.0	Screw M 5x 12-A2-70 (In6Rd)	7.000	ST		
X-X	3	7.313-016.0	Spring washer B 5-1.4310 DIN 127	7.000	ST		
X-X	4	5.116-417.0	Bearing sleeve	1.000	ST		
	5	7.306-042.0	Cylinder head screw M8x25 -8.8-A2E ISO4	2.000	ST		
X-X	6	7.311-427.0	Hexagon nut M8 -04-A2E ISO 10511	2.000	ST		
X-X	7	7.312-004.0	Washer 8 -200HV-A3E ISO 7090	2.000	ST		
X	8	4.481-300.0	Add-on kit tension rod	2.000	ST		
X-X	9	7.310-041.0	Knurled nut M10- St-E2E DIN 467	2.000	ST		
X-X	10	7.311-423.0	Hexagon nut M10 -04-A2E ISO 10511	2.000	ST		
X-X	11	6.401-471.0	Eye screw LB-5.6 M10x60	2.000	ST	M10x60	PAY ATTENTION TO VERSION
	11	6.401-475.0	Eye screw LB-5.6 M10x70	2.000	ST	M10x70	PAY ATTENTION TO VERSION
X-X	12	7.304-525.0	Hexagonal head screw M10x30-A4-70 ISO 4	2.000	ST		
X-X	13	6.330-432.0	Extension spring	2.000	ST		
	14	7.303-259.0	Eye screw BM 8x40-4.6-A2E DIN 444	2.000	ST		
X-X	15	4.058-339.0	Sheet metal component lever pipe kpl.	1.000	ST		
X-X	16	5.116-416.0	Bearing sleeve	2.000	ST		
X-X	17	4.058-167.0	Plate pipe complete	1.000	ST		
X-X	18	7.312-013.0	Washer 20-A2 ISO 7090	1.000	ST		
X-X	19	7.343-007.0	Locking ring 20x1,2-FST-RF DIN 471	1.000	ST		
X-X	20	7.316-209.0	Bolt B10,0x55-ST-A2E ISO 2341	1.000	ST		
X-X	21	7.312-005.0	Washer 10-200HV-A3E ISO 7090	4.000	ST		
X-X	22	7.316-347.0	Cotter 3,2x25-St-A2E ISO 1234	3.000	ST		
X-X	23	7.316-206.0	Bolt B10,0x45-ST-A2E ISO 2341	1.000	ST		
X-X	24	6.613-311.0	Hoisting motor 24V 60mm	1.000	ST		

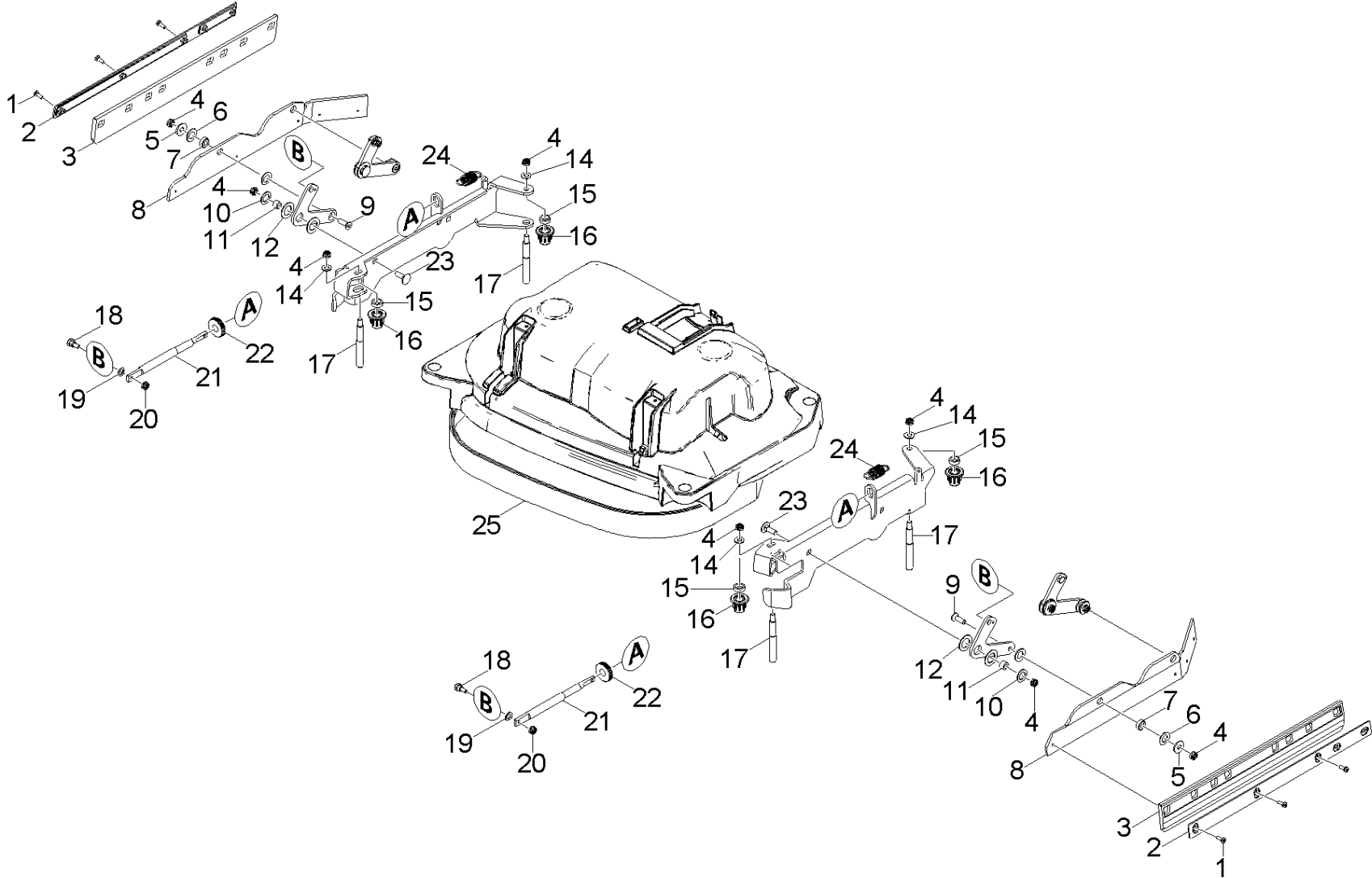

65 Add-on kit side strip stiffener (0.165-898.0)

ET/VT (spare/wear parts)	Pos	Material #	Name	Qty.	Unit	Footnote text
X-X	1	7.303-037.0	Screw M5x10 -St-P2R (In6Rd)	6.000	ST	
X-X	2	5.044-867.0	Retainer strip splash guard	2.000	ST	
X-X	3	5.394-911.0	Splash guard	2.000	ST	
X-X	4	7.311-432.0	Hexagon nut M 8-1.4305 ISO 10511	12.000	ST	
X-X	5	7.312-017.0	Washer 8-A2 ISO 7089	4.000	ST	
X-X	6	5.115-744.0	Washer	8.000	ST	
	7	5.112-419.0	Bush	4.000	ST	
	8	5.763-082.0	Holder splash guard right	4.000	ST	
X-X	9	7.305-627.0	Countersunk screw M8x25-A2-70 ISO 10642	4.000	ST	
X-X	10	7.312-268.0	Washer 8 -A2 ISO 7094	4.000	ST	
X-X	11	5.112-810.0	Sleeve VA	4.000	ST	
X-X	12	5.115-432.0	Washer	8.000	ST	
	13	5.763-098.0	Sheet metal component suspension side sp	2.000	ST	
X-X	14	5.115-375.0	Washer	4.000	ST	
	15	5.115-641.0	Washer	4.000	ST	
X	16	5.033-339.0	Sleeve deflector roll	4.000	ST	
	17	5.317-603.0	Bolt	4.000	ST	
	18	5.305-220.0	Screw	4.000	ST	
X	19	7.343-103.0	Shim ring 10x16x1,0 -A2 DIN 988	4.000	ST	
X-X	20	7.311-422.0	Hexagon nut M 6-1.4305 ISO 10511	4.000	ST	
	21	5.763-097.0	Shaft adjustment	2.000	ST	
	22	7.310-018.0	Knurled nut M12 -St-A2K DIN 467	2.000	ST	
X-X	23	7.303-203.0	Saucer-head screw M 8x25-A2 DIN 603	4.000	ST	
	24	6.330-457.0	Spring	2.000	ST	
X-X	25	5.365-222.0	cSealing lip	1.000	M	TO ORDER AS CUT GOODS

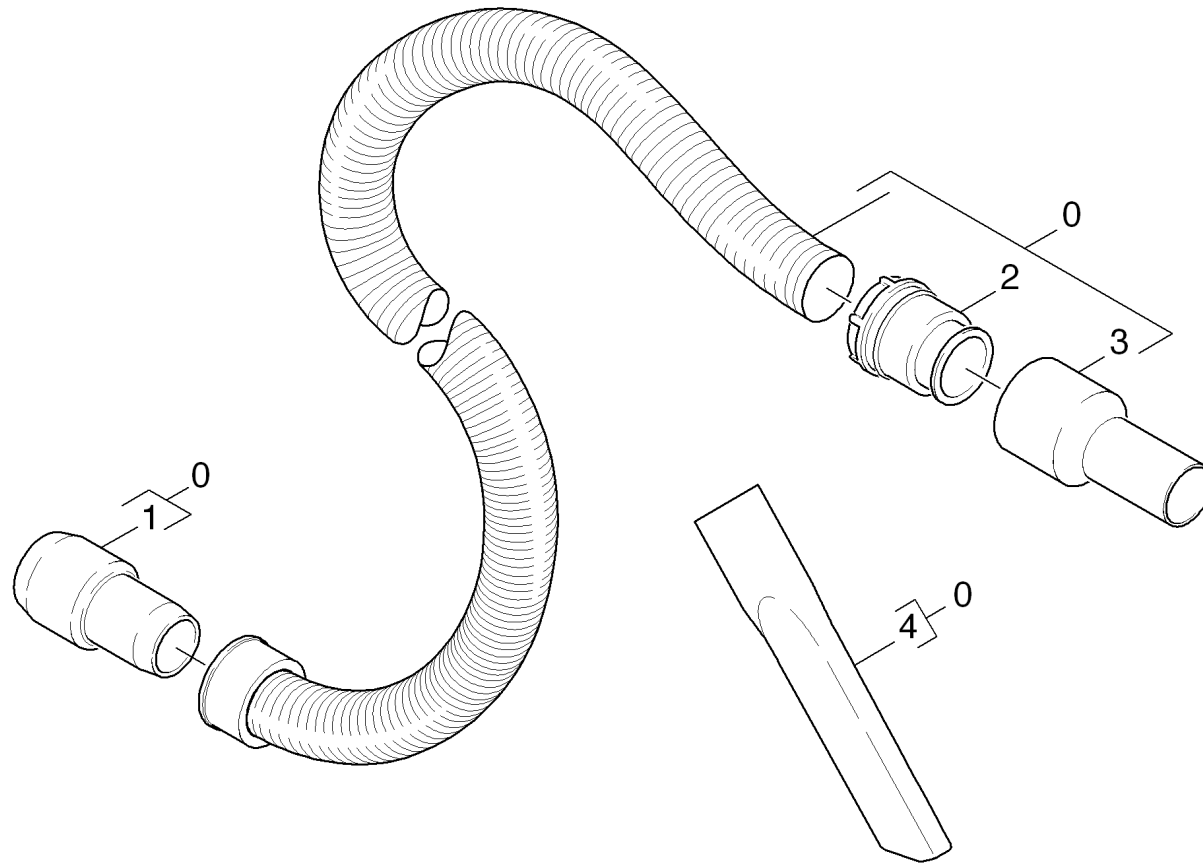

**70 Suction hose (0.164-346.0)**

ET/VT (spare/wear parts)	Pos	Material #	Name	Qty.	Unit	from ser.nr.	up to ser.nr.
X-X	0	4.444-015.0	Suction hose accessories	1.000	ST	0000000000	0000000000
	1	5.453-055.0	Connecting sleeve	1.000	ST	0000000000	0000000000
	2	6.902-031.0	Threaded ring DN32	1.000	ST	0000000000	0000000000
	3	6.902-030.0	Sleeve NW35	1.000	ST	0000000000	0000000000
X-X	4	6.906-240.0	Crevice nozzle DN35	1.000	ST	0000000000	0000000000

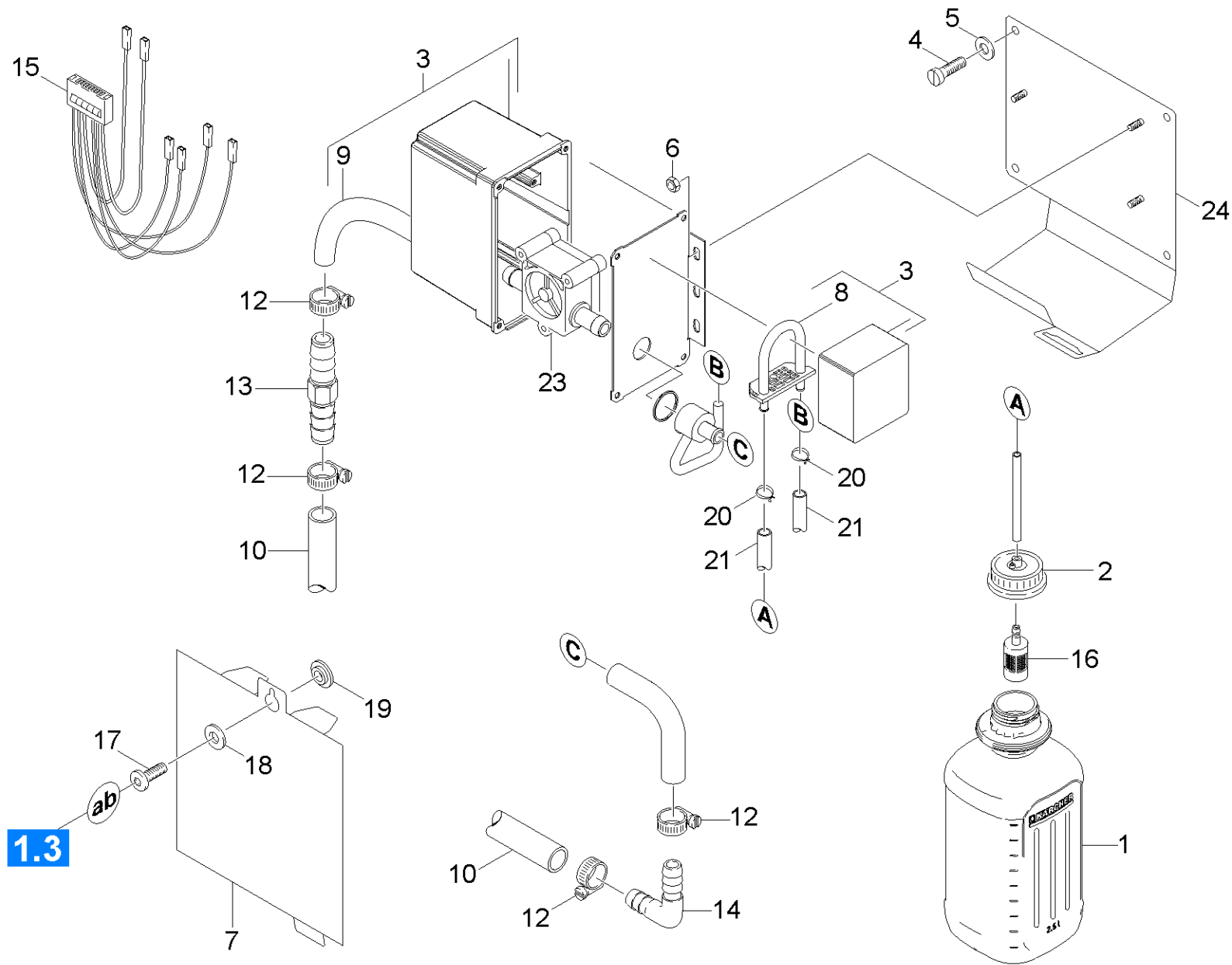



80 Metering unit chemistry (0.164-401.0)

ET/VT (spare/wear parts)	Pos	Material #	Name	Qty.	Unit	from ser.nr.	up to ser.nr.	Footnote text
X-X	1	6.394-491.0	Bottle PE 2,5 L	2.000	ZST	0000000000	0000000000	
	2	4.060-833.0	Cover cleaning agents	1.000	ST			YELLOW
X-X	2	4.060-625.0	Cover cleaning agents	1.000	ST			BLACK
X-X	3	6.470-179.0	Dosing pump chemistry	1.000	ST			
	4	7.306-077.0	Screw M5x16 -8.8-R2R (In6Rd)	4.000	ST	0000000000	0000000000	
X	5	7.312-002.0	Washer 5-200HV-A3E ISO 7090	4.000	ST	0000000000	0000000000	
X-X	6	7.311-421.0	Hexagon nut M 5-04-A2E ISO 10511	3.000	ST	0000000000	0000000000	
	7	5.008-943.0	Covering cap chemistry	1.000	ST	0000000000	0000000000	
X-X	8	5.443-625.0	Hose dosing pump nur f. Ersatz	1.000	ST			
	9	5.035-039.0	Rubber bushing rubber EPDM	1.000	ST	0000000000	0000000000	
X-X	10	6.390-892.0	Spiral hose NW12	1.000	M	0000000000	0000000000	TO ORDER AS CUT GOODS
	11	6.388-216.0	Hose DN 5	1.000	M	0000000000	0000000000	TO ORDER AS CUT GOODS
X-X	12	6.388-545.0	Hose clip	4.000	ST	0000000000	0000000000	
X-X	13	6.388-715.0	Rubber bushing 14	1.000	ST	0000000000	0000000000	
X	14	6.388-628.0	Elbow connector 1/2"	1.000	ST			
	15	4.822-421.0	Cable harness switch control panel	1.000	ST	0000000000	0000000000	
	16	5.731-652.0	Filter with weight	1.000	ST	0000000000	0000000000	
X-X	17	7.306-089.0	Screw M6x12 -8.8-R2R (In6Rd)	1.000	ST			
	18	7.312-027.0	Washer 6-KUNSTSTOFF ISO7089	1.000	ST			
	19	6.392-160.0	Sleeve insulating M6	1.000	ST			
X	20	6.389-924.0	Hose clip	2.000	ST			
X-X	21	6.391-341.0	Hose chemistry DN 6	1.000	M			TO ORDER AS CUT GOODS
X-X	23	6.429-038.0	Flowmetre	1.000	ST			
	24	5.008-944.0	Holder chemistry	1.000	ST			

**200 Special tools (0.120-581.0)**

Pos	Name	Qty.	Unit
200	Tool measuring instrument current AC/DC,	1.000	ST
210	Tool tool - extractor system Molex	1.000	ST
220	Tool tool - extractor -Bolt Circle	1.000	ST
230	Tool torque key 2-25Nm	1.000	ST
240	Tool magnetic brake adapter	1.000	ST
250	Tool service module A9	1.000	ST
260	Tool hydrometer acid	1.000	ST
270	Tool potentiometer DC	1.000	ST
280	Tool magnetic field tester	1.000	ST
290	Tool tester electric Metratester5	1.000	ST

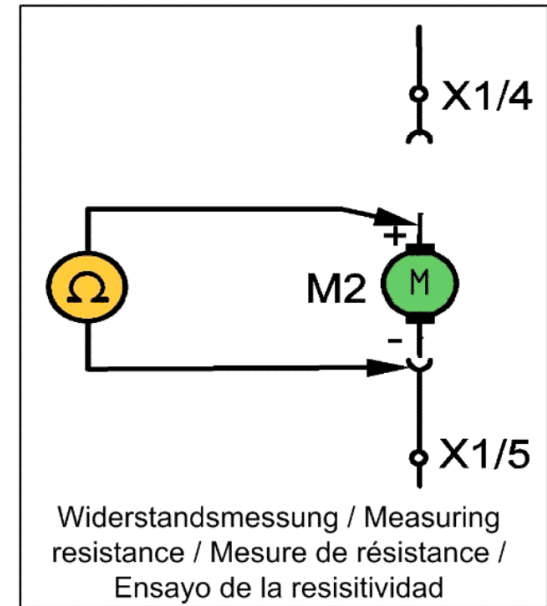
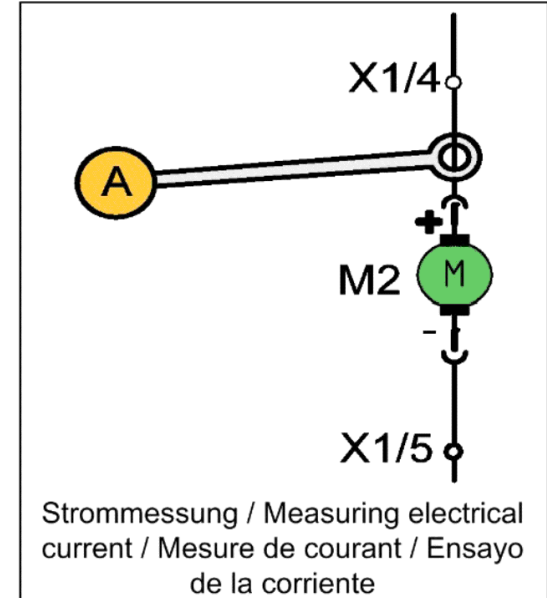
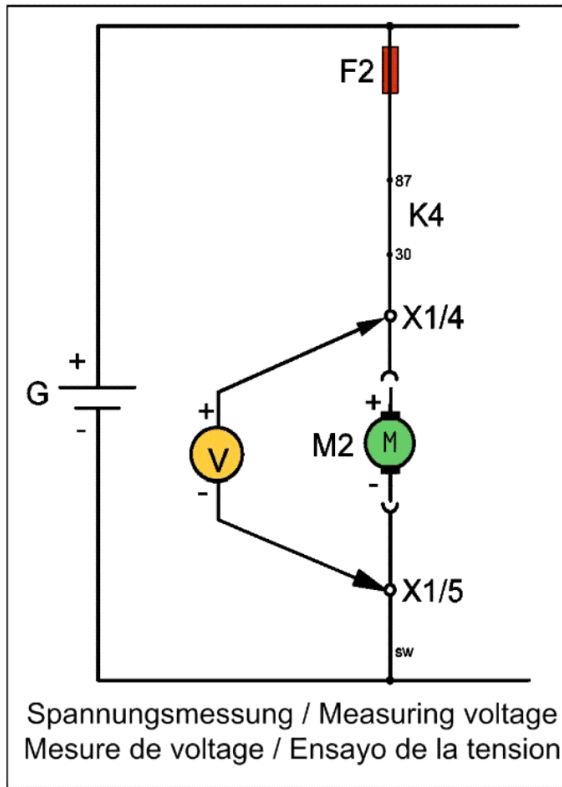
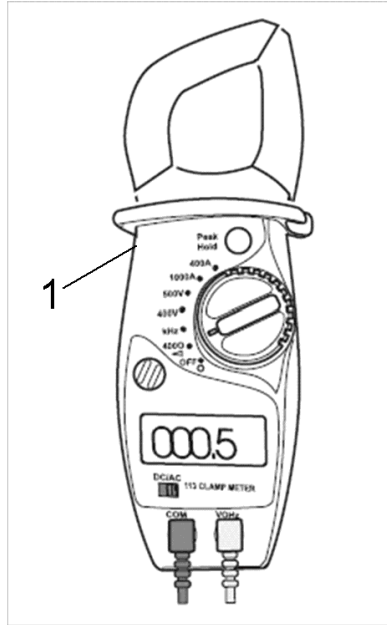

200 Tool measuring instrument current AC/DC, (0.120-008.0)

---

Pos	Material #	Name	Qty.	Unit
1	6.803-022.0	Clamp meter AC/DC,A,V,Ohm	1.000	ST

---

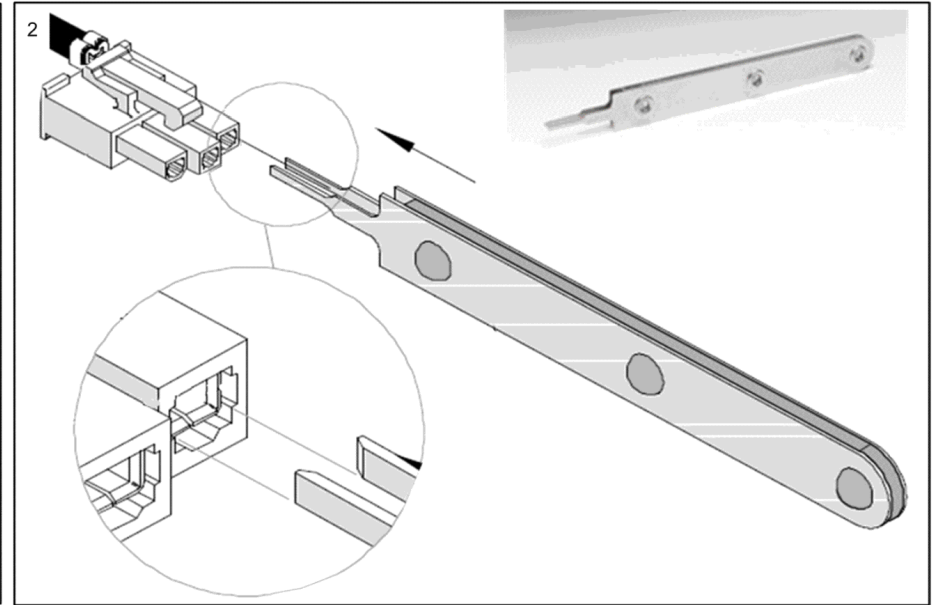
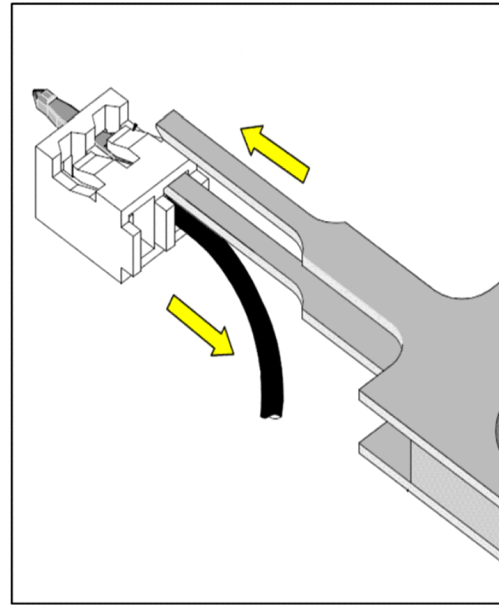
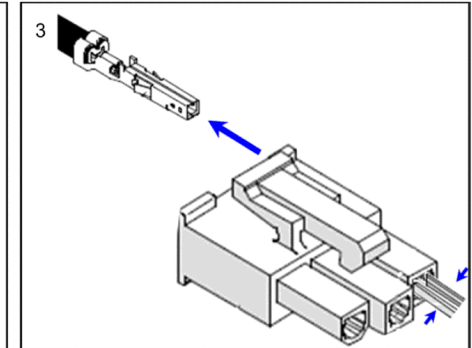
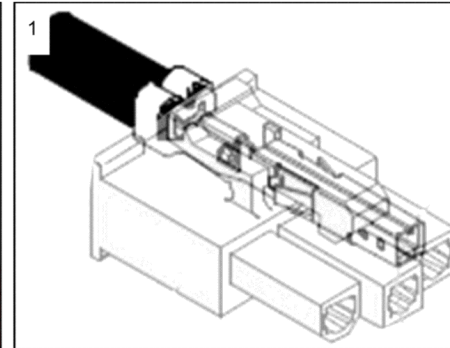
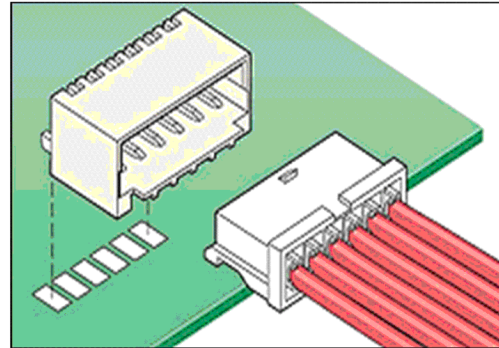
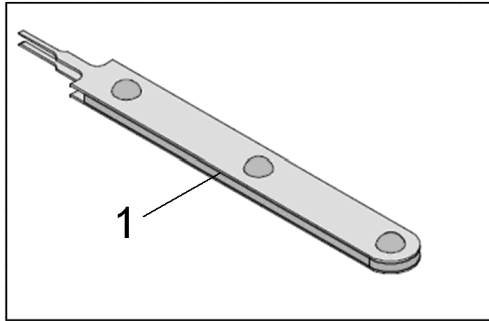

210 Tool tool - extractor system Molex (0.120-082.0)

---

Pos	Material #	Name	Qty.	Unit
1	6.816-086.0	Pliers Molex	1.000	ST

---

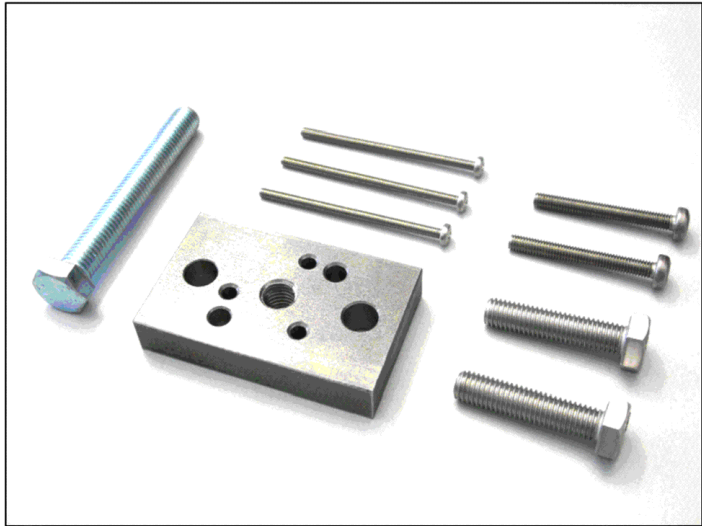

1

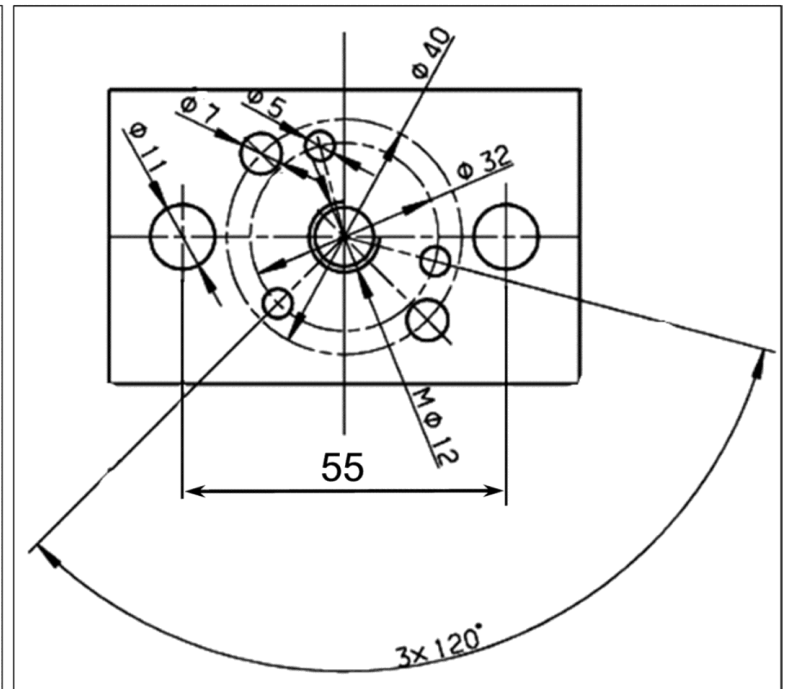
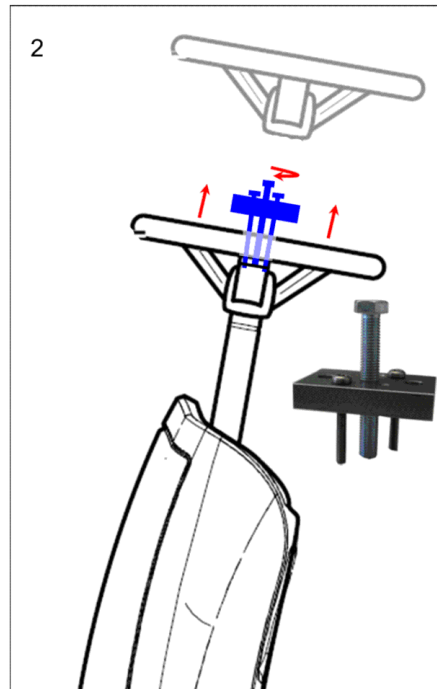
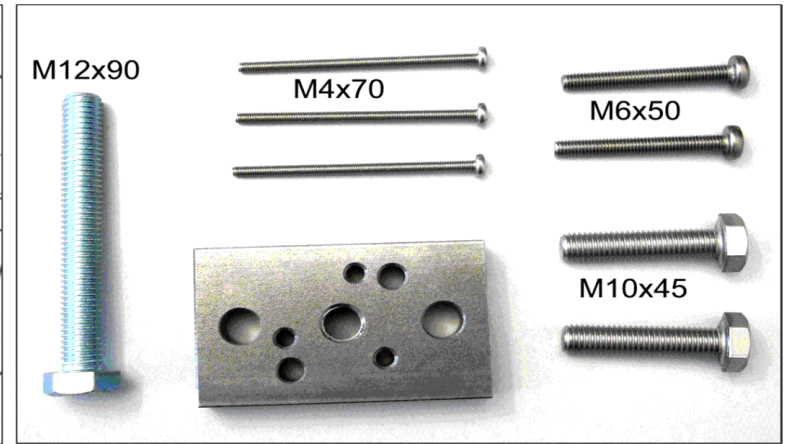
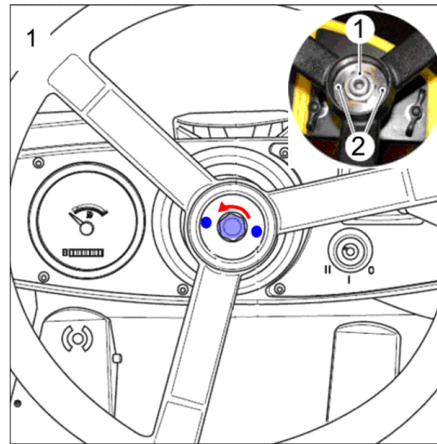

220 Tool tool - extractor -Bolt Circle (0.120-083.0)

---

ET/VT (spare/wear parts)	Pos	Material #	Name	Qty.	Unit
X	1	2.860-166.0	Toolkit steering wheel blower ICC1/ICC2	1.000	ST

---



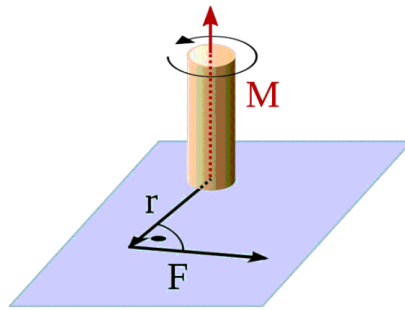
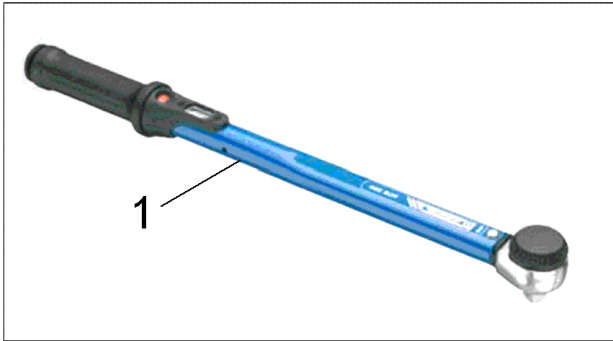

$$M = r \times F$$

M = Drehmoment / Torque [Nm]  
 r = Radius / Rayon / Radio [m]  
 F = Kraft / Force / Fuerza [N]

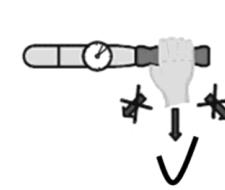
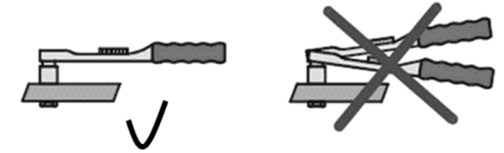
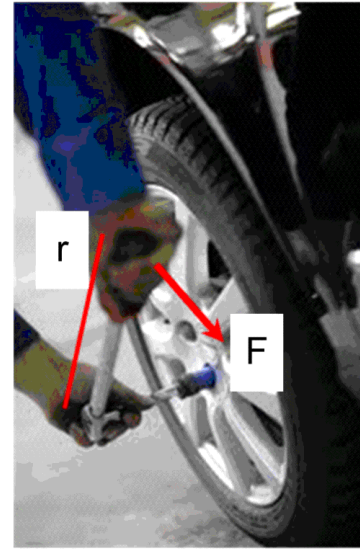

3/8"  
 r = 285mm  
 2 – 25 Nm  
 +/- 3%

5 lbf ft = 678 cNm

	= mN·m	<u>= cN·m</u>	= N·m	= ozf·in	= lbf·in	= lbf·ft	= gf·cm	= kgf·cm (kp·cm)	= kgf·m (kp·m)
1 mN·m	1	0,1	0,001	0,142	0,009	0,0007	10,2	0,01	0,0001
1 cN·m	10	1	0,01	1,416	0,088	0,007	102	0,102	0,001
1 N·m	1000	100	1	141,6	8,851	0,738	10197	10,2	0,102
1 ozf·in	7,062	0,706	0,007	1	0,0625	0,005	72	0,072	0,0007
1 lbf·in	113	11,3	0,113	16	1	0,083	1152,1	1,152	0,0115
<u>1 lbf·ft</u>	1356	<u>135,6</u>	1,356	192	12	1	13826	13,83	0,138
1 gf·cm	0,098	0,01	0,0001	0,014	0,0009	0,00007	1	0,001	0,00001
1 kgf·cm (kp·cm)	98,07	9,807	0,098	13,89	0,868	0,072	1000	1	0,01
1 kgf·m (kp·m)	9807	980,7	9,807	1389	86,8	7,233	100000	100	1

230 Tool torque key 2-25Nm (0.120-084.0)

---

Pos	Material #	Name	Qty.	Unit
1	6.815-090.0	Torque spanner 2-25Nm	1.000	ST

---

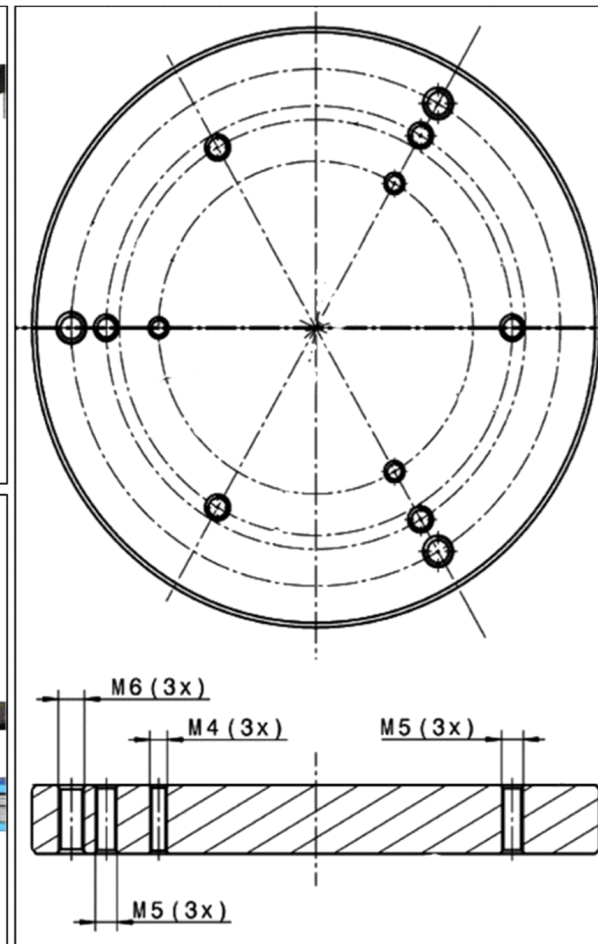
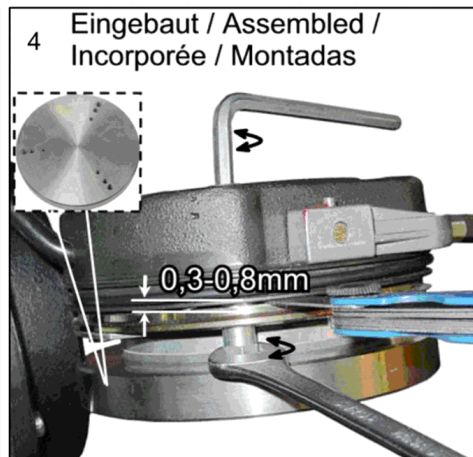
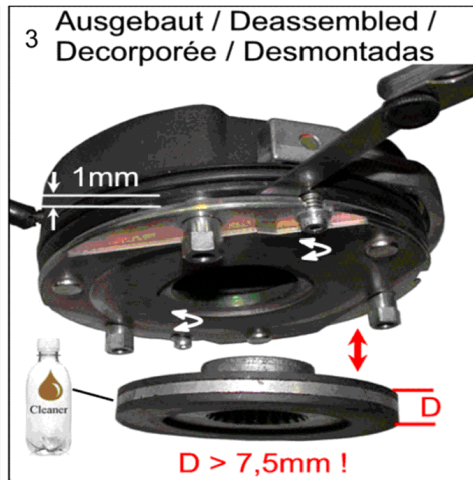
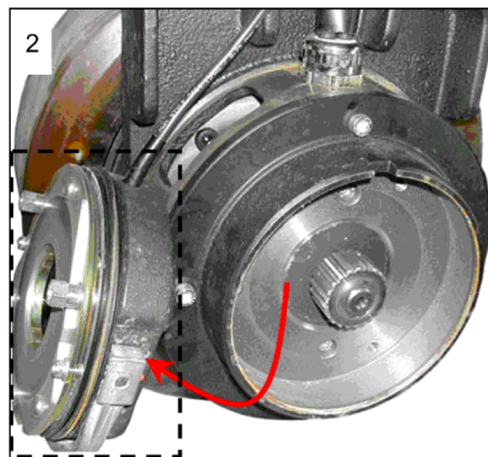
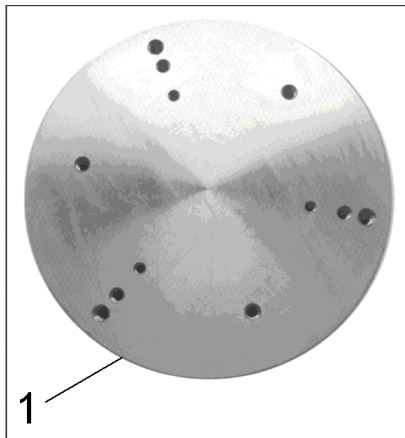

240 Tool magnetic brake adapter (0.120-085.0)

---

Pos	Material #	Name	Qty.	Unit
1	5.116-199.0	Washer brake service	1.000	ST

---

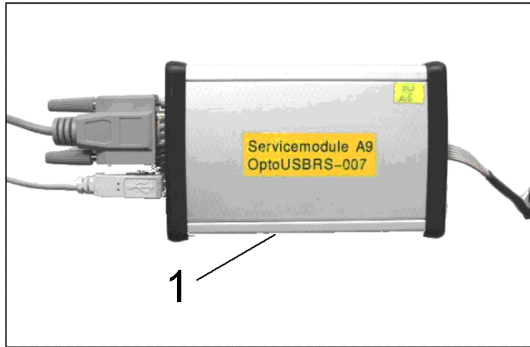

**Preparations**

**Downloading Installation Files for Service Program**  
 1. Use Computer with USB and Admin rights  
 2. Copy Folder: C:\Kaecher to C:\Kaecher\_save  
 3. Open Kärcher-Inside:  
 DOKUMENTE -> SERVICE -> DOWNLOADS, SCRUBBERS AND SWEEPERS -> SERVICEMODUL-> SERVICE PROGRAMM V5.1-> UPDATE x  
 "Service Program Version V5.2 - Installation\_CD\_USBStick"

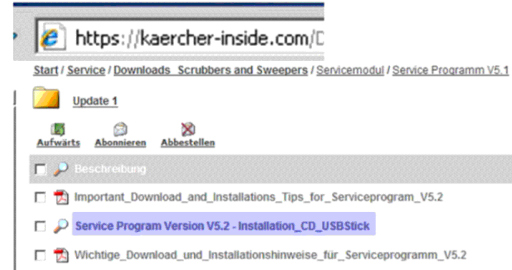

Create external drive and start Installation from there.  
 1. Mark extracted files and folder and copy to the external drive  
 2. Start „Autostart.exe“ in the external drive.

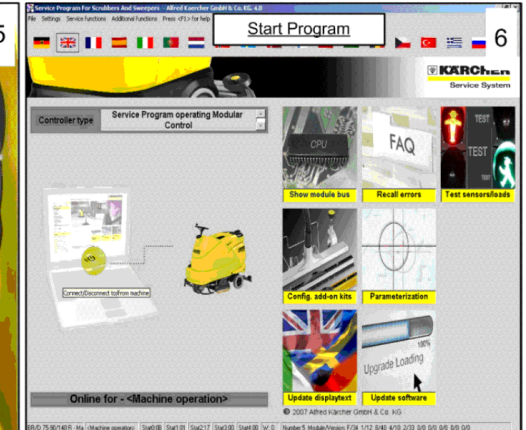
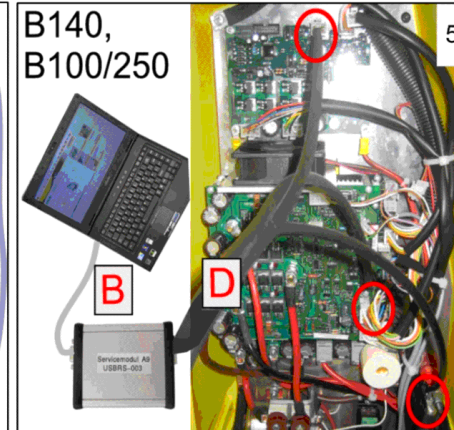
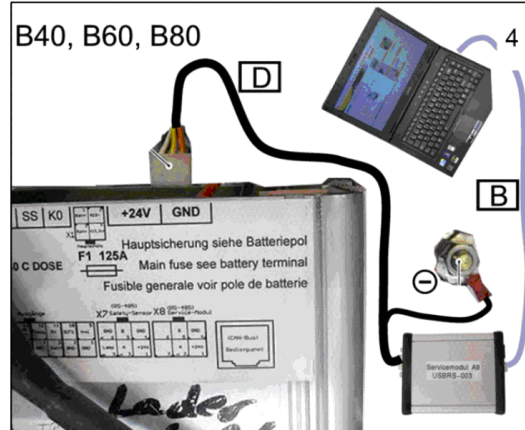
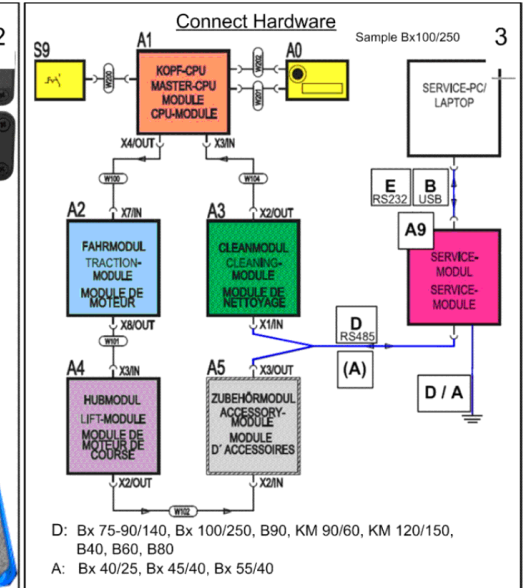
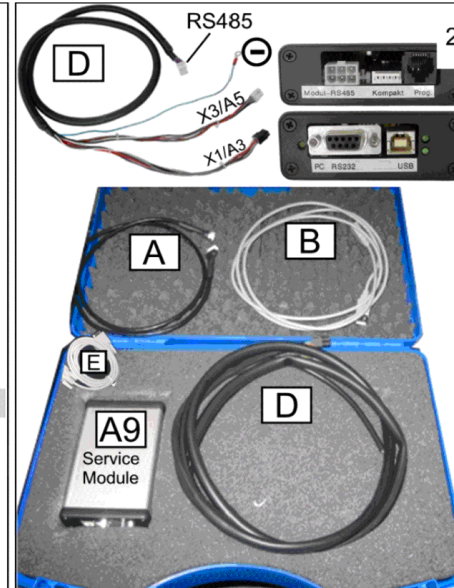

250 Tool service module A9 (0.120-086.0)

---

ET/VT (spare/wear parts)	Pos	Material #	Name	Qty.	Unit
X-X	1	2.816-117.0	Service module A9	1.000	ST

---



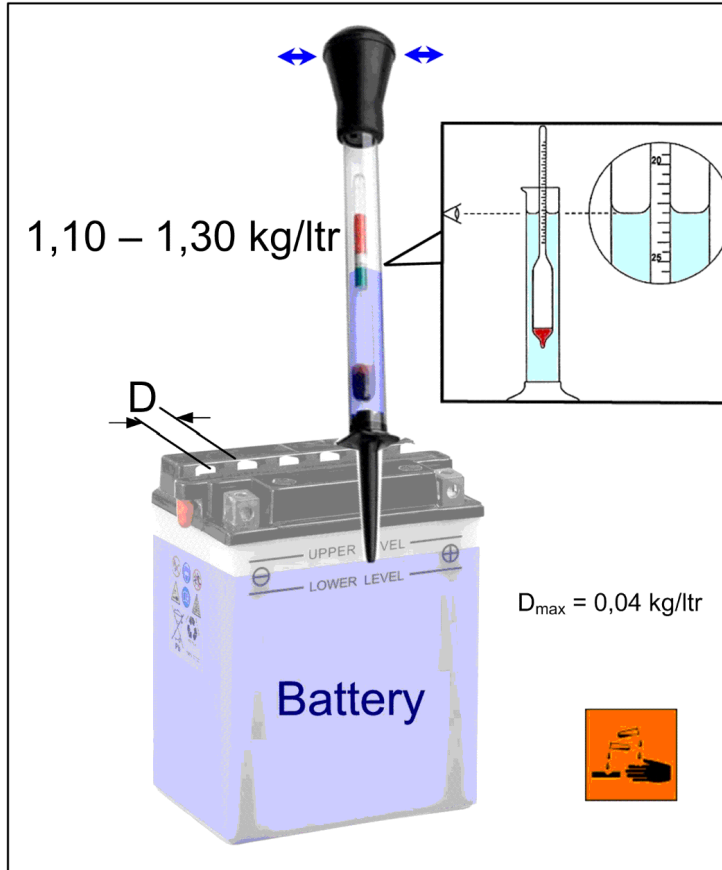
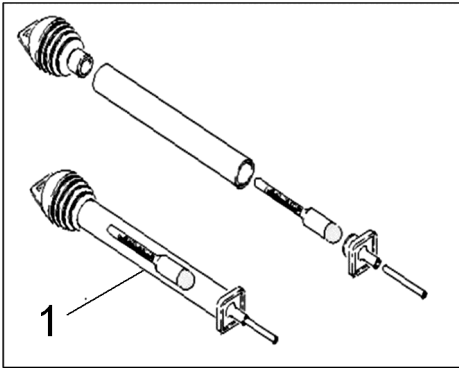

12-Volt Batterie / Battery / Bateria	Ladung / Charge / Carga	Säuredichte / Density / Densité / Densidad [kg/l]	30°C
> 12,80 Volt	100%	1,29	
> 12,55 Volt	75%	1,25	
> 12,32 Volt	50%	1,21	
> 12,18 Volt	25%	1,14	
> 12,00 Volt	entladen / discharge / décharge / descarga	< 1,13	

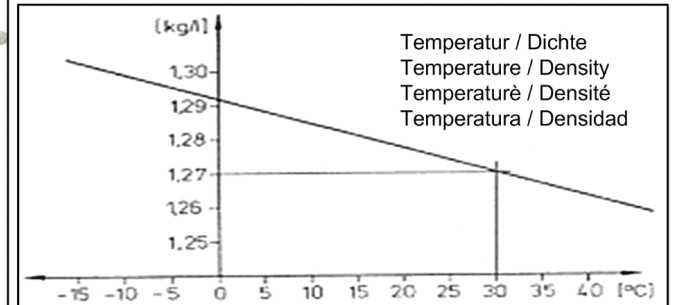

260 Tool hydrometer acid (0.120-087.0)

---

Pos	Material #	Name	Qty.	Unit
1	6.803-015.0	Battery hydrometer 1,10-1,30kg/l	1.000	ST

---



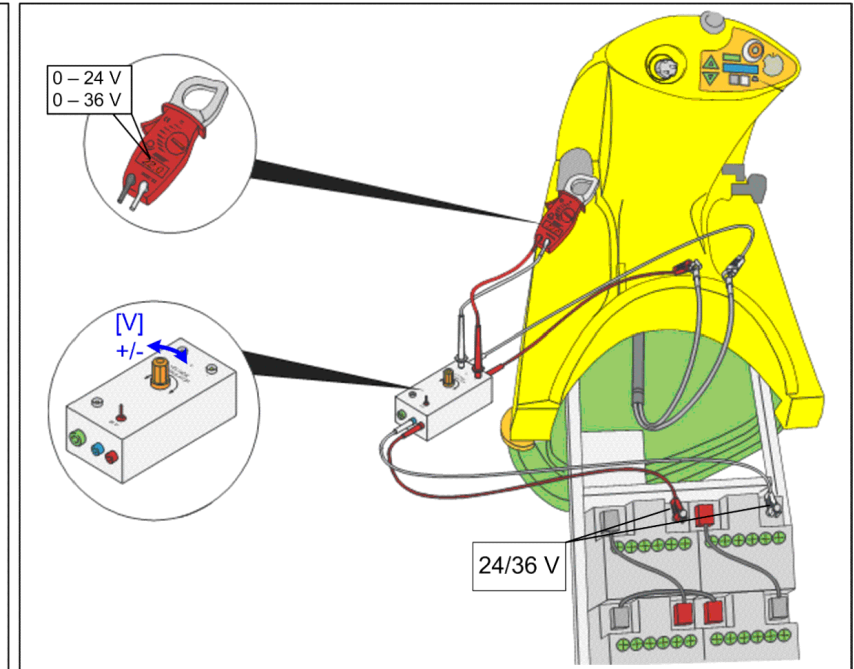
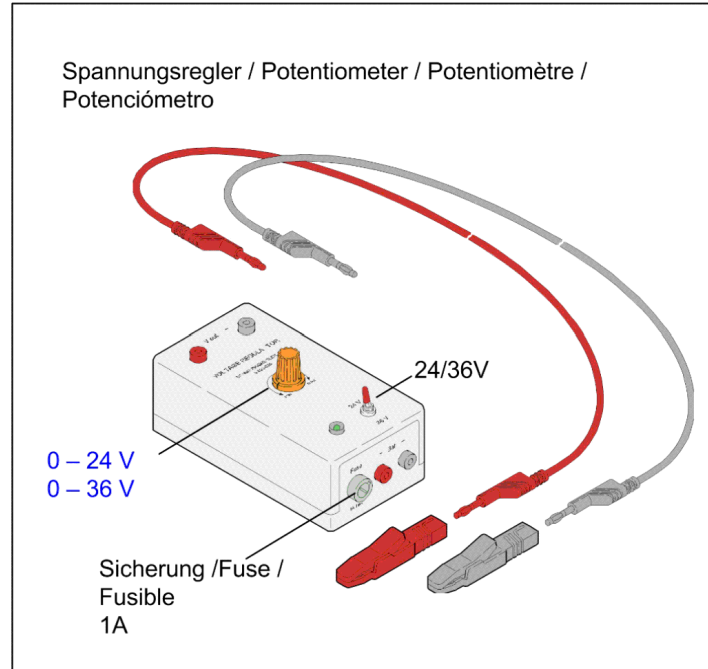
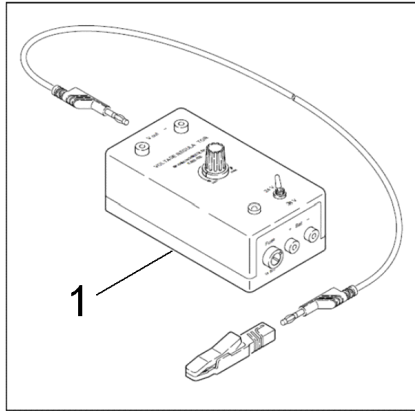

270 Tool potentiometer DC (0.120-088.0)

---

Pos	Material #	Name	Qty.	Unit
1	6.803-025.0	Voltage tester 24/36V,DC	1.000	ST

---

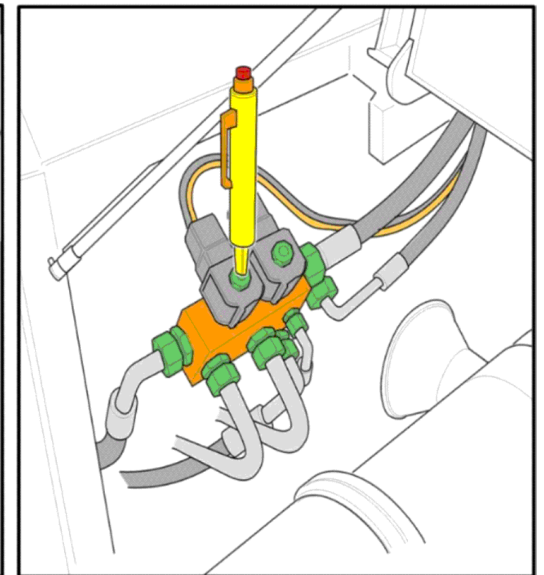
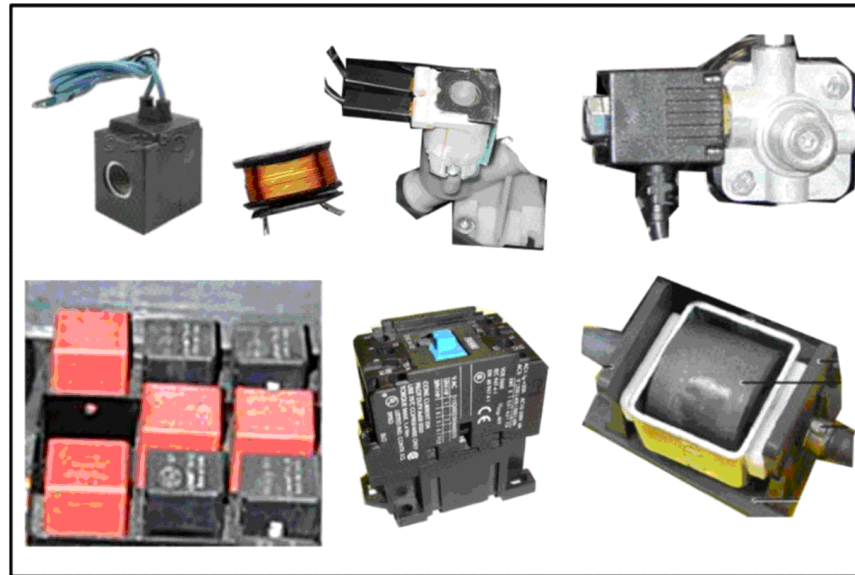
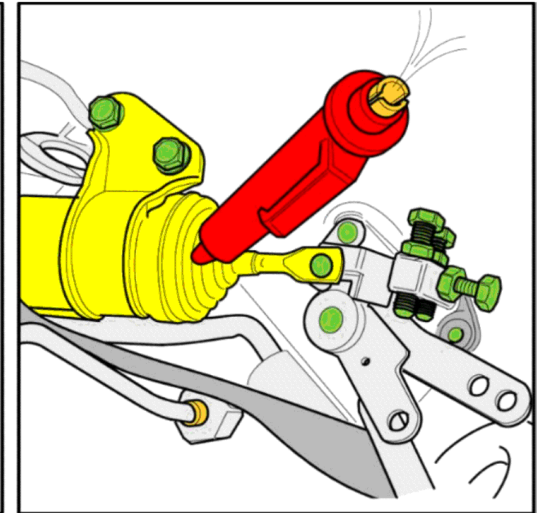
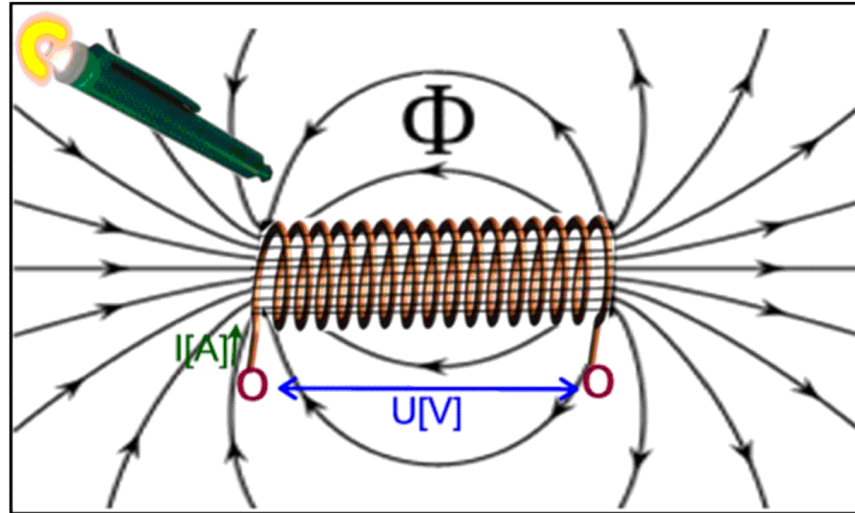
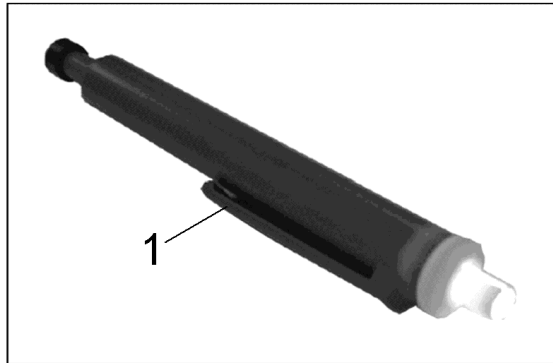

280 Tool magnetic field tester (0.120-104.0)

---

Pos	Material #	Name	Qty.	Unit
1	6.803-003.0	Magnet tester	1.000	ST

---



Das Prüfgerät ist zum Prüfen und Messen an instandgesetzten oder geänderten elektrischen Geräten nach DIN VDE 0701 oder DIN VDE 0702 bestimmt. Gemäß diesen Vorschriften müssen nach einer Instandsetzung oder Änderung elektrischer Geräte der Schutzleiterwiderstand, der Isolationswiderstand, der Ersatz-Ableitstrom und bei Datenverarbeitungseinrichtungen und Büromaschinen die Spannungsfreiheit berührbarer leitfähiger Teile gemessen werden.

The tester is intended for the testing and measurement of repaired or modified electrical devices in accordance with DIN VDE 0701-702. These regulations require the measurement of protective conductor resistance, insulation resistance and equivalent leakage current for repaired or modified electrical devices, as well as testing for the absence of voltage at exposed, conductive parts for data processing systems and office machines.

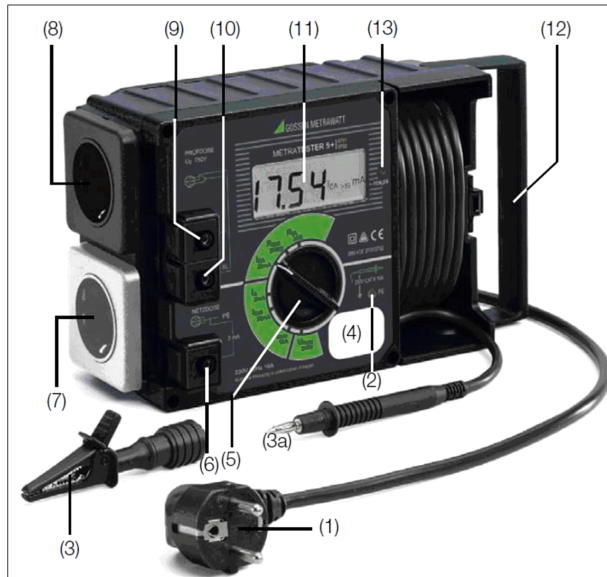

(2) Signallampe PE zur Prüfung des Schutzleiters  
Die Signallampe PE leuchtet, wenn zwischen der berührten Kontaktfläche (4) und dem Schutzkontakt des Netzanschlusstekers (1) eine Potentialdifferenz von  $\geq 100$  V besteht.  
(3) Krokodilklemme (Greifklemme zum Aufstecken auf die Prüfspitze)  
Mit der Krokodilklemme schließen Sie, zur Messung des Schutzleiterwiderstandes, das Gehäuse des Prüflings an. Achten Sie dabei auf guten Kontakt.  
(4) Kontaktfläche für Fingerkontakt  
Beim Berühren der Kontaktfläche leuchtet die Signallampe (2), wenn zwischen dem Schutzleiter PE des Netzanschlusstekers (1) und der berührten Kontaktfläche eine Potentialdifferenz von  $\geq 100$  V besteht. Die Kontaktfläche ist von allen Anschlüssen und von der Messschaltung galvanisch getrennt und entspricht somit der Schutzklasse III  
Prüfen des Schutzleiterpotentials  
Berühren Sie mit dem Finger die Kontaktfläche (4) und gleichzeitig ein geerdetes Teil (z.B. Wasserleitung). Die Signallampe PE (2) darf dabei nicht leuchten! Das Potential zwischen dem Schutzleiter des Netzanschlusstekers (1) und der Kontaktfläche (4) ist dann  $\leq 100$  V.

(2) PE Signal Lamp for Protective Conductor Testing  
The PE signal lamp lights up, if a potential difference of  $\geq 100$  V occurs between the contacting surface (4) and the earthing contact at the mains plug (1).  
(3) Alligator clip (gripper clip for attachment to the test probe)  
Connect the housing of the device under test with the alligator clip for measurement of protective conductor resistance.  
(4) Contacting Surface for Contact Finger  
The PE signal lamp (2) lights up, if a potential difference of  $\geq 100$  V occurs between the PE protective conductor at the mains plug (1) and the contacting surface. The contacting surface is electrically isolated from all terminals, as well as from the measuring circuit, and thus conforms to protection class III!  
Testing Protective Conductor Potential  
Bring the contact finger into contact with the contacting surface (4) and, at the same time, with a grounded object (e.g. a water pipe). The PE signal lamp (2) must not light up! Potential between the mains plug protective conductor (1) and the contacting surface (4) is then  $\leq 100$  V.

Anschließen des Prüflings (A) an das Prüfgerät  
Für die Messung von Schutzleiterwiderstand, Isolationswiderstand und Ersatz-Ableitstrom

Connecting the Device Under Test to the Test Instrument  
for the measurement of protective conductor resistance, insulation resistance and equivalent leakage current

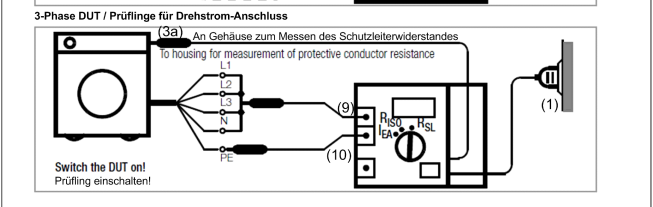
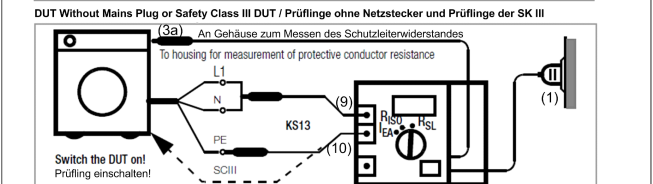
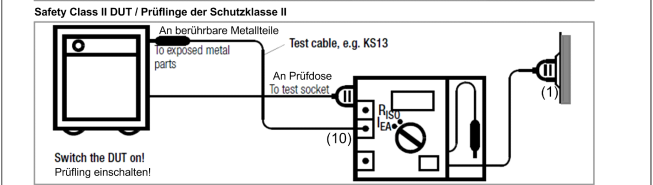
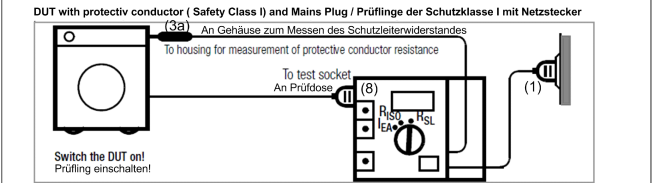

290 Tool tester electric Metrater5 (0.120-160.0)

---

Pos	Material #	Name	Qty.	Unit
1	6.803-034.0	Electrical tester Metrater5	1.000	ST

---